



BBC-R AGRO

Bearings and units for the Agriculture Industry

2021

Content

1. About the company	3
2. Quality control	4
3. Distributors	5
4. Bearing seals – range overview	7
5. Bearing interchange	8
6. Rostselmash	9
7. Tillage	11
8. Seeding	42
9. Baling and Harvesting	60
10. Deep groove ball bearings	71
11. Agro-HUB	75
12. Notes	81





ABOUT THE COMPANY

Group of companies Baltic Bearing Company (corporate brand BBC-R) is a state-of-the-art enterprise equipped with modern production and measurement equipment with the quality management system conforming to the requirements of ISO9001, ISO14001, ISO50001 series standards.

Manufacturing equipment allows to produce a wide range of bearings, from single row radial ball bearings to plain bearings. All precision equipment is in conformity with the requirements of EU standards that guarantees its safe operation and will ensure high-quality manufacture of products. All the equipment in the production workshop is installed as short automatic process lines classified by the constructive groups of groundwork pieces.

Workshops are equipped with modern machining centers and CNC systems, grinding machines, assembly lines, which have EU certificates and widely used in Europe, Asia and the USA.

The statistical quality control techniques and automation systems of all processes are applied on all operations, providing high efficiency, reliability, and stability of the equipment.

All production lines are equipped with up-to-date automatic quality control systems, ensuring consistent high quality of manufactured parts.

NEW PRODUCTION SITE OF BALTIC BEARING COMPANY

We are pleased to inform our partners and customers that Baltic Bearing Company is expanding its production capabilities by acquiring additional production facilities in Rezekne (Latvia) since August, 2020. The main purpose of this site is turning of bearing blanks and turning and milling of housings for insert bearing assemblies.

Engagement of these operations takes our Company to a higher level of processing and production.

The turning equipment, which the Baltic Bearing Company plant in Rezekne is equipped with, is able to provide a high level of blank quality for subsequent heat treatment, grinding and assembly. This technological process was launched to form a complete production cycle for BBC-R series bearings of the EMQ (Electric Motors Quality). These bearings are subject to increased requirements for vibro-acoustic parameters, the formation of which largely depends on the quality of turning operations.

Moreover, the turning and milling capacity of the new plant of Baltic Bearing Company will allow machining of housing castings for their subsequent assembly with bearings.

This will allow us not only to improve the quality of already mastered insert bearing assemblies, but also to expand the product line with the help of new engineering solutions. A new level of quality will be achieved through step-by-step control of the technological process from procurement of raw materials to painting and assembly. The short-range plan of our Company includes introduction of a new series of BBC-R reinforced insert bearings made of impact-resistant high-strength cast iron GGG50, which has modified microstructure that provides higher strength characteristics compared to grey cast iron. Combined with a new generation of Baltic Bearing Company AGRO SHELL seals, BBC-R AGRO insert bearing assemblies and bearings can provide a completely new level of durability for your agricultural machinery under extreme loads.

In addition, the R&D department of Baltic Bearing Company is working on the expansion of the BBC-R EMQ series line of products for electric motors.

Expansion of production capabilities, implementation of modern engineering solutions, development of new markets, improvement of product quality and end-user satisfaction is a priority goal of Baltic Bearing Company in the near future!

QUALITY CONTROL

A three-stage system of control is organized at the plant: incoming inspection of supplied materials and work pieces, periodical inspection of bearing parts grinding and acceptance inspection of finished bearings.

State-of-the-art dust-free materials and technologies were used to construct the laboratory premises. The entrance to the laboratory is equipped with an air lock chamber. Temperature and air cleanness in the laboratory are ensured by an autonomous ventilation system. All this provides for a microclimate that conforms to all standards ensuring consistency and high quality of measurements.

The laboratory is equipped with up-to-date high-precision equipment from leading producers, enabling the company to carry out a wide range of bearings and bearing parts investigations, such as:

- measuring of micro- and macro geometric parameters (roughness, out-of-roundness, cylindricality, planarity, straightness, ripple, etc.);
- linear and angular measurements;
- metallographic testing (steel make, structure, hardness, presence of grinding burns);
- samples testing for load at failure;
- vibration control;
- visual examination of surface defects;
- contamination and magnetization analysis;
- certification and periodic verification of reference measuring instruments.

To carry out high-quality investigation, the laboratory is equipped with all necessary equipment for samples preparation: cutting machine, thermal press, grinding and polishing machine, chemical pickling cells.

The plant is equipped with more than 40 types of manual inspection tools to carry out an incoming inspection of raw material and components as well as bearing parameters during grinding.

To verify samples used for adjustment of manual inspection tools, a length gage is purchased and put into operation.



Own production

More than 360 units of modern high precision equipment have been installed in production workshops.



Highly qualified staff

The company employees have a great experience in the bearing industry. Many of them worked in the leading bearing companies.



High product quality

The quality management system extends to the development, production and supply of bearing products to consumers.



Quality control

Each batch of components for the production of bearings passes input control according to the drawings.



Distributors

- Bulgaria
- Czech Republic
- Estonia
- Finland
- Germany
- Greece
- Latvia
- Lithuania
- Moldova
- Poland
- Romania
- Serbia
- Slovakia
- Turkey
- Ukraine
- United Kingdom





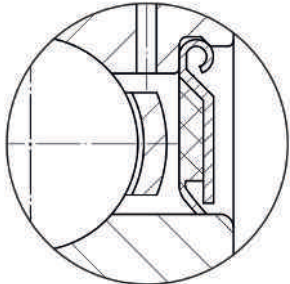
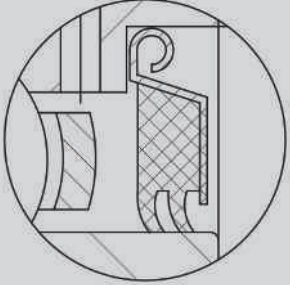
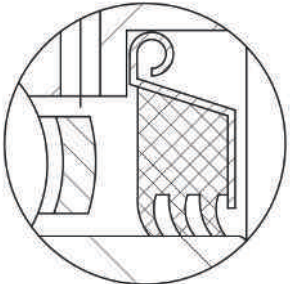
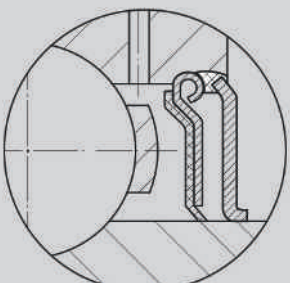
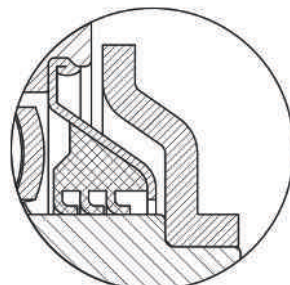
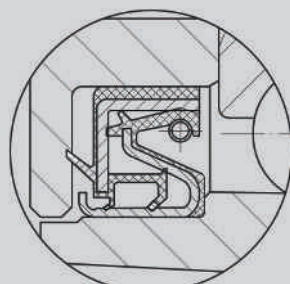

A light gray map of Europe with white outlines of countries and islands. Twelve red dots are placed on the map, representing various locations across the continent. The dots are located in the following approximate regions: Sweden, Finland, Denmark, Germany, Poland, Czech Republic, Slovakia, Hungary, Austria, Italy, Greece, and Turkey.

**We are developing together with you,
we are developing for you!**

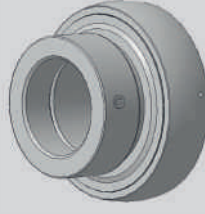
Bearing seals – range overview

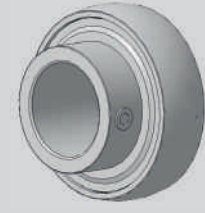
Seal type	Description	Application max. speed (r/min)	Drawing
Single-lip seal.	The friction and speed in this type of bearing seal are the same as with standart contact seal, but protection from dirt, dust, fibre wrap and abrasion is much better.	4000	
Duble-lip seal.	Duble-lip seal is applied with wide inner ring bearings, also it is available for disc harrow bearings with round shafts.	2000	
Triple-lip seal reinforced with sheet steel.	Triple-lip seal is applied only with special bearings for the agricultural machines. It also available for UC bearing series. The steel sheet design protects the seal lips from dirt, dust, fibre wrap and abrasion. Triple-lip seal units solve the most difficult sealing problems.	600	
Single-lip seal with an adjustment flinger.	Two contact lips made with NRB are forming double labirinth system. Additional metal cover provides reliable mechanical protection. Available for flanged bearings and assemblies on demand.	2000	
Triple-lip seal with metal cover for extra havy duty working conditions.	Triple-lip seal used for very dirty environments, reinforced with additional protection: metal cover provides reliable mechanical protection. It protects bearing from aggressive presence of foreign matter. Available for flanged bearings and assemblies.	500	
Cassette seal presents the best sealing system for application in agricultural machinery.	Multi-lip cassette seal provides maximum protection against liquid or solid contaminants, which significantly extends bearing service life. Availaable for Disc harrows, sowing machines.	400	

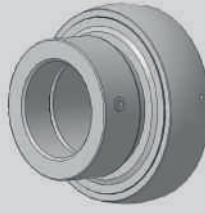
Bearing interchange

BBC-R	SKF	INA	SNR	Timken	NSK	IMAGE
AEL2(00).LV	YET2(00)-2F	GRAE(00)NPPB	ES2(00)G2	GRAE(00)RRB	AEL2(00)W3	
UEL2(00).LV	YEL2(00)-2F	GE(00)KRRB	EX2(00)G2	GE25KRRB	UEL2(00)D1W3	
UC2(00).LV	YAR2(00)-2F	GYE(00)KRRB	UC2(00)G2	GYE(00)KRRB	UC2(00)D1	
AS2(00).LV	YAT2(00)-2F	GAY(00)NPPB	US2(00)G2	GYAE(00)RRB	AS2(00)	
17262(00)2RS.LV	17262(00)-2RS1	20(00)NPPB	62(00)SEE	-	17262(00)-2RS	
UEL3(00).LV	-	GNE(00)KRRB	EX3(00)G2	-	UEL3(00)D1W3	
UC3(00).LV	-	-	UC3(00)	-	UC3(00)	



Rostselmash



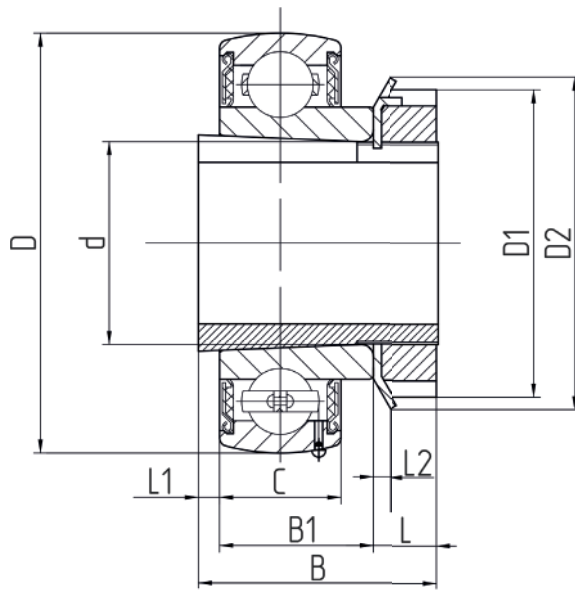

Figure 1

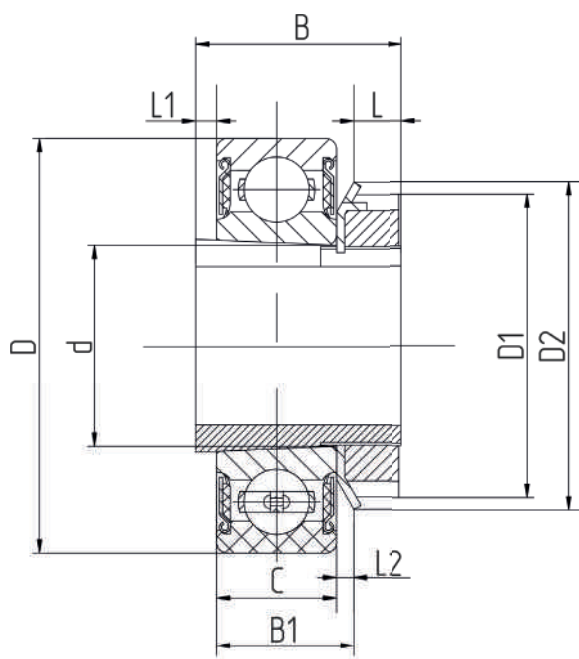

Figure 2

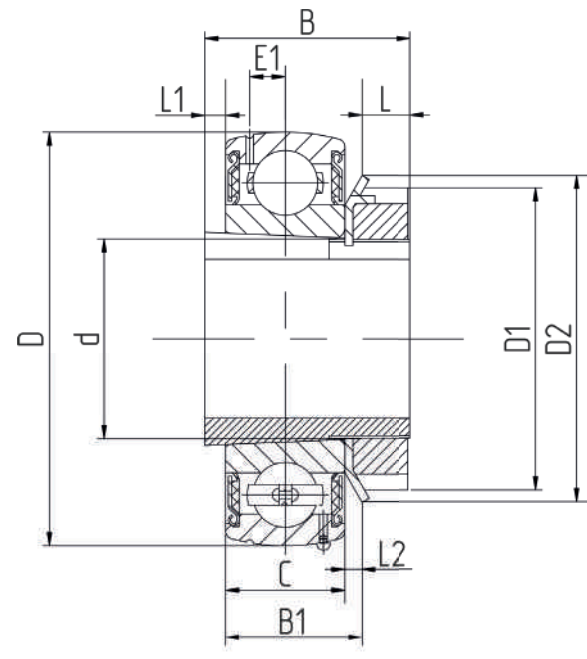

Figure 3

Designation BBC-R	FKL	Shaft d	Dimention (mm)										Figure
			D	D1	D2	B	B1	C	L	L1	L2	E1	
1680204.LV	UH 205/20 2S.H.T	20	52	38	42.3	29	18	16	7	1	1.25	4.3	1
1680205.LV	UH 206/25 2S.H.T	25	62	45	49	32	20	18	7	1	1.25	5	1
1680206.LV	UH 207/30 2S.H.T	30	72	52	57	35	22	19	8	1	1.25	5.7	1
1680207.LV	UH 208/35 2S.H.T	35	80	58	62	36	23	21	9	1	1.25	6.5	1
1680208.LV	UH 209/40 2S.H.T	40	85	65	69	39	23	21	10	1	1.25	6.5	1
380706.LV	UH 209/30 2S.SH	30	85	52	57	35	23	23	8	1	1.25	-	2
380707.LV	UH 209/35 2S.SH	35	85	58	62	36	23	23	9	1	1.25	-	2
380708.LV	UH 209/40 2S.SH	40	85	65	69	39	23	23	10	1	1.25	-	2
680210.LV	UH 211/50 2S.T	50	100	75	81	45	25	25	11	1	1.25	7	3
680314.LV	UH 217/70 2S.T	70	150	105	112	70	45	39	15	1	1.75	12	3



Tillage

Soil cultivation is the first stage of agricultural work which is usually carried out twice a year, in spring and autumn. Its purpose is to prepare the soil for new crops. To do this, using agricultural implements, the nutrient soil is raised to the surface, as well as the introduction of the crop residues remaining on the surface into the lower layers of the cultivated soil.

Another important step in soil cultivation is soil crushing to achieve the right balance of moisture and air to avoid soil erosion. This process is carried out through the use of disk agricultural implements. As practice shows, the benefits for the farmer who use high-quality components in their equipment can include an increase in productivity up to 150% and a reduction in the cost of ownership of equipment up to 30%. All this is possible due to the trouble-free operation of the equipment for a long period of time.

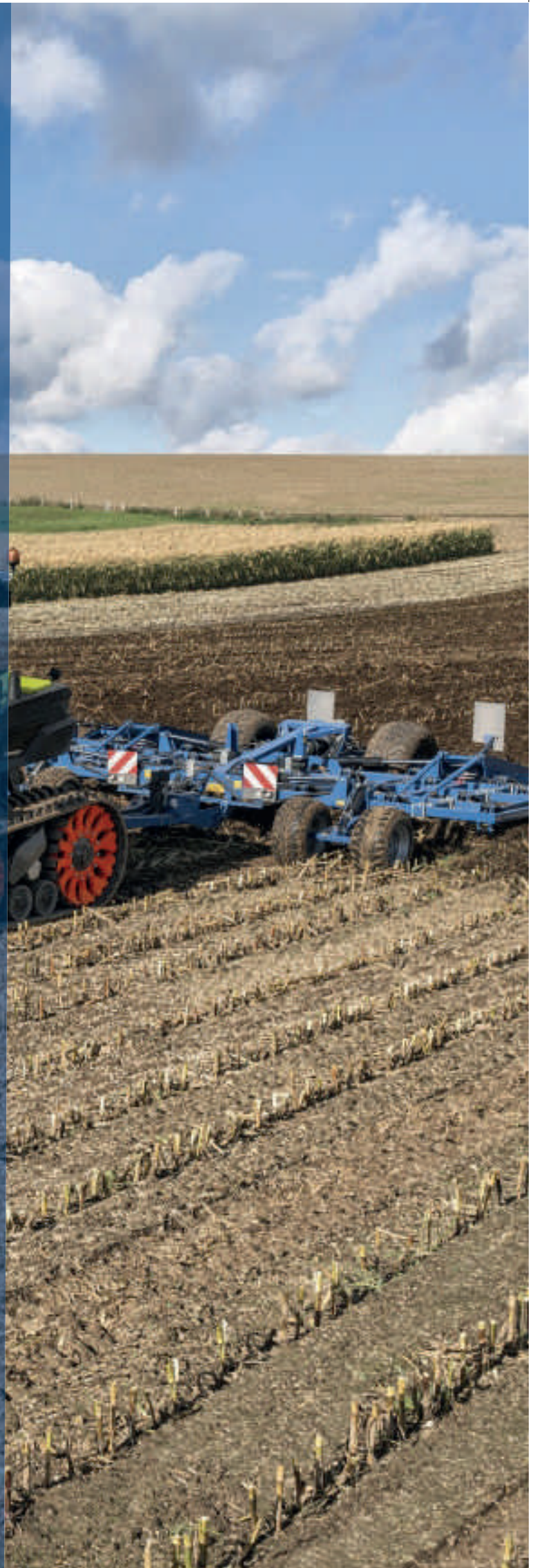

Operating conditions

Application conditions:

- 1) Operating conditions: high abrasiveness, increased moisture, dustiness, dirt.
- 2) Peak shock loads, high tangential and axial loads on the bearing units of the working bodies.
- 3) Increase productivity by increasing the speed of movement of agricultural implements.
- 4) Solving the problem of equipment downtime in the shortest possible time (often repairs are carried out in the field).

To ensure the trouble-free operation of the rotating mechanisms of the soil cultivation implements, it is imperative to use bearings and bearing assemblies adapted to the field conditions. Bearings must have a high degree of protection against dirt and abrasion. The design and quality of bearings must ensure trouble-free operation of agricultural implements during agricultural work. Otherwise, labour productivity is significantly reduced, which leads to loss of profit for the farmer.

Typical operating conditions for disc harrow unit hubs

High speed of the tractor up to 12 km / h. Using 2-3 bearing assemblies for the entire disc battery. High unsprung mass of the disc harrow unit. Rigid connection between the discs leads to the distribution of the load on all bearing assemblies of the unit from collision with an obstacle of one of the discs. Large degree of burial and close proximity to the ground of bearing assemblies. All these factors form the harsh operating conditions of the harrow bearing assemblies.

Solution for use in disc harrow unit hubs

The most widely used in this type of soil cultivation implements is the use of special non-collapsible bearing assemblies with a high degree of protection. BBC-R offers non-separable bearing units with increased load ratings.

Typical operating conditions for a disc harrow with free-standing discs

Deep loosening is an agrotechnical operation to change the structure of the surface layer of the soil to ensure optimal conditions for the flow of air and moisture to the root system of plants. The main tool for this operation is heavy disc harrows. The disc diameter of such tools sometimes exceeds 800 mm. Soil preparation is carried out by burying the hemispherical discs into the soil to a depth of 200 mm, followed by cutting and turning the soil. Often, soil preparation work is carried out on virgin lands, as a result of which extreme peak loads from collisions with obstacles are added to the difficult operating conditions of the bearing assemblies. The characteristics of the movement of the tillage machine are as follows: disk rotation speed: 90-350 rpm. tractor travel speed over 20 km/h.

Solutions for free-standing disc harrow unit hubs

For use on free-standing disc harrow unit hubs, BBC-R offers both bearings and bearing assemblies. One of the successful technical solutions is the use of AGRO HUB units. The use of a bearing assembly based on a double-row angular contact bearing in combination with a maintenance-free design and a five lip seal, can significantly increase the productivity of the soil processing process. Extended mean time between failures (MTBF), Minimum time for assembly replacement, Possibility of unimpeded replacement of the assembly on sight significantly increases the economic indicators of agriculture.

Solutions for soil chopper hubs (Roller)

The soil chopper hubs can be configured with case bearings of various configurations. However, the main unifying condition for this type of product is a high degree of dirt protection and the ability to operate without fail under conditions of unplanned peak loads. BBC-R offers its customers a wide range of solutions to ensure the reliable operation of agricultural machinery.

851001999.LV

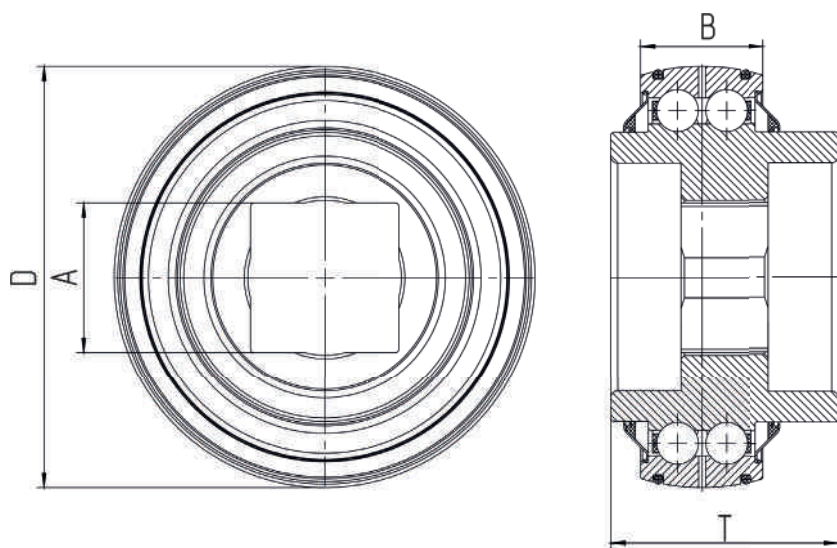

CROSS REFERENCE

Producer	OEM numbers
RBF Gregoire Besson Emopak	PN00031 851001999

Designation BBC-R	Application	Bore type	Description	A	D	T	B
851001999.LV	Gang disc – Tillage units	Square bore bearing	Tillage / Secondary tillage – Gang disc	42,5	120	65	35

AKK16196.LV

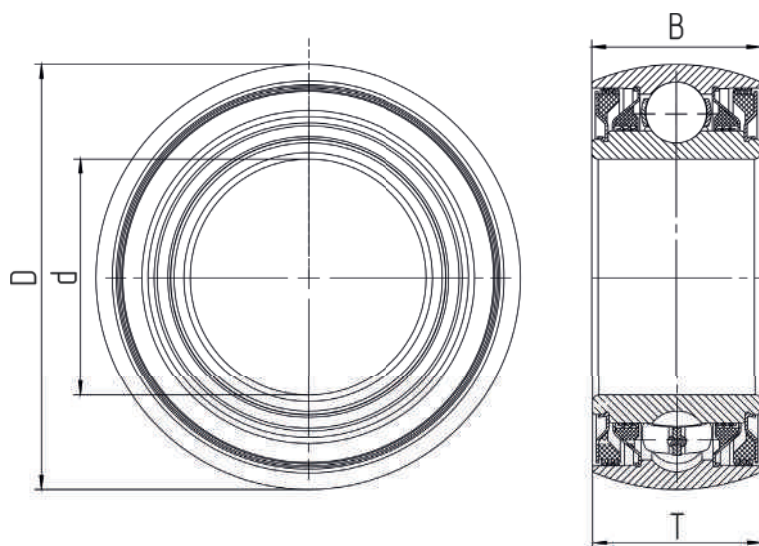

CROSS REFERENCE

Producer	OEM numbers
Peer John Deere John Deere	W211K55 IQ AKK16196 AN241911

Designation BBC-R	Application	Bore type	Description	d	D	T	B
AKK16196.LV	Gang disc – Non-relubricatable bearings	Round bore bearing	Tillage / Secondary tillage – Gang disc	55,7	100	39,69	39,69

W208PP5.LV

CROSS REFERENCE

Producer	OEM numbers
Timken	W208PP5
Clark	6510843B1231
CNH	232471
CNH	963889R91
CNH	H747139
Federal Moful	TN208S1
John Deere	JD9350
John Deere	PMCW208PP5
Lilliston	7950006
Massey Ferguson	1025130M1
Massey Ferguson	PS01002
National	DC 208 TT5
NDH	AS4508BH
Timken	W 208 PP20

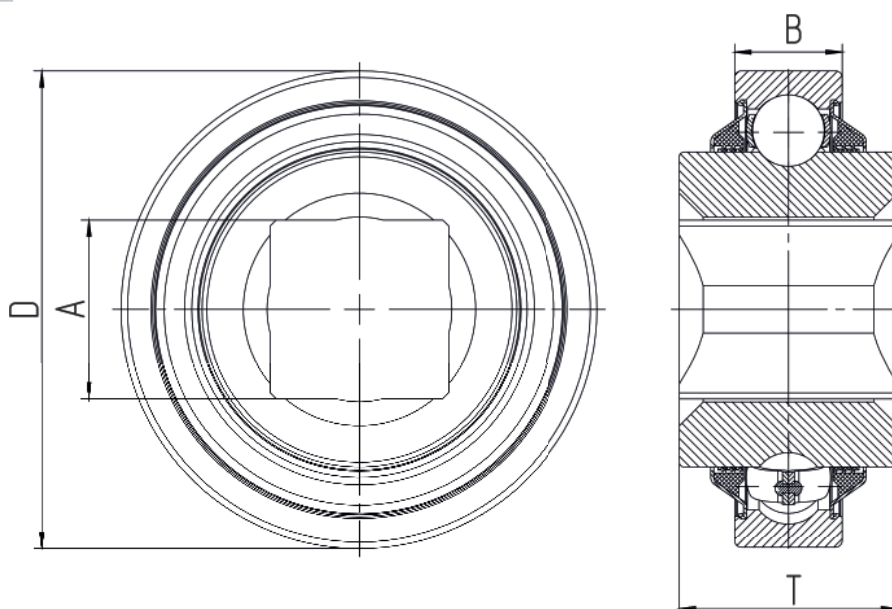

Designation BBC-R	Application	Bore type	Description	A	D	T	B
W208PP5.LV	Gang disc – Non-relubricatable bearings	Square bore bearing	Tillage / Secondary tillage – Gang disc	28,575	80	36,513	18

GW208PP17.LV

CROSS REFERENCE

Producer	OEM numbers
Timken	GW208PP17
BCA	DC 208 TTR17
Bush Hong	1436183
Great Plains	822-001C
Gaspardo	G1436183

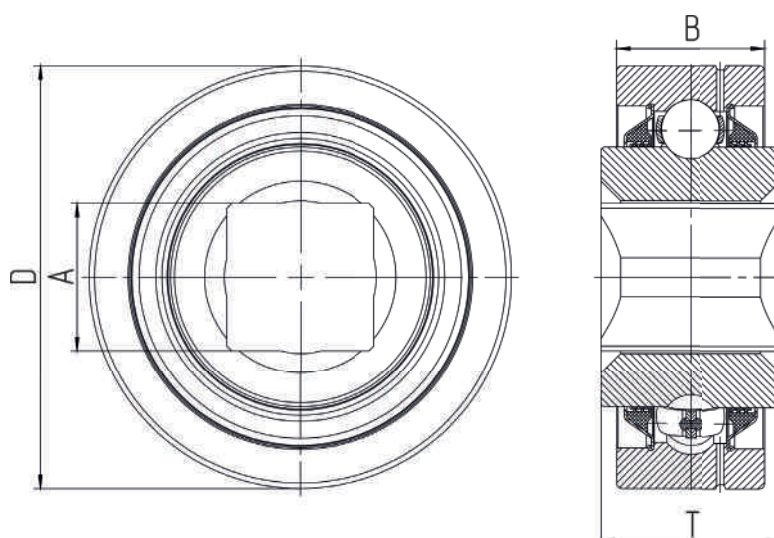

Designation BBC-R	Application	Bore type	Description	A	D	T	B
GW208PP17.LV	Gang disc – Relubricatable bearings	Square bore bearing	Tillage / Secondary tillage – Gang disc	28,575	85,74	36,525	30,175

W208PP8.LV

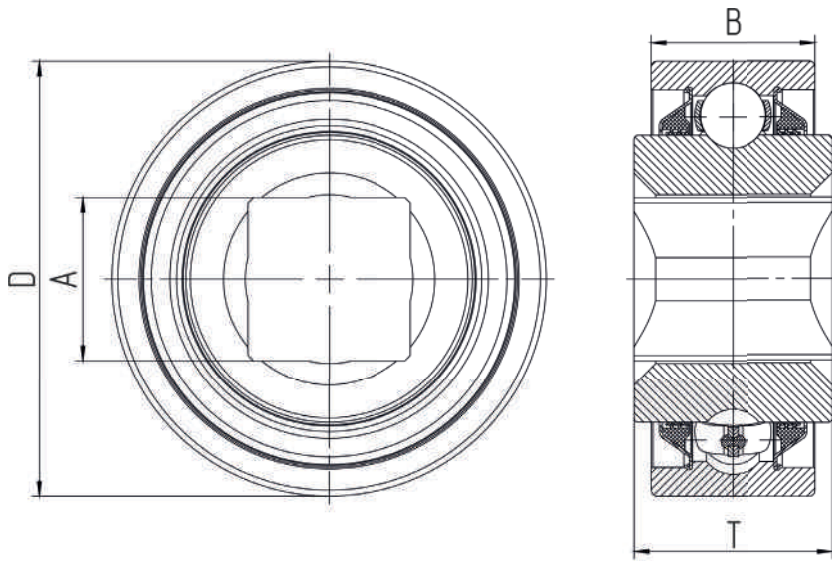

CROSS REFERENCE

Producer	OEM numbers
Timken	W208PP8
Brillion	9C16
John Deere	AA14878
John Deere	JD9286
BCA	DC 208 TT8

Designation BBC-R	Application	Bore type	Description	A	D	T	B
W208PP8.LV	Gang disc – Relubricatable bearings	Square bore bearing	Tillage / Secondary tillage – Seedbed finisher	29,972	80	36,53	30,18

W208PPB12.LV

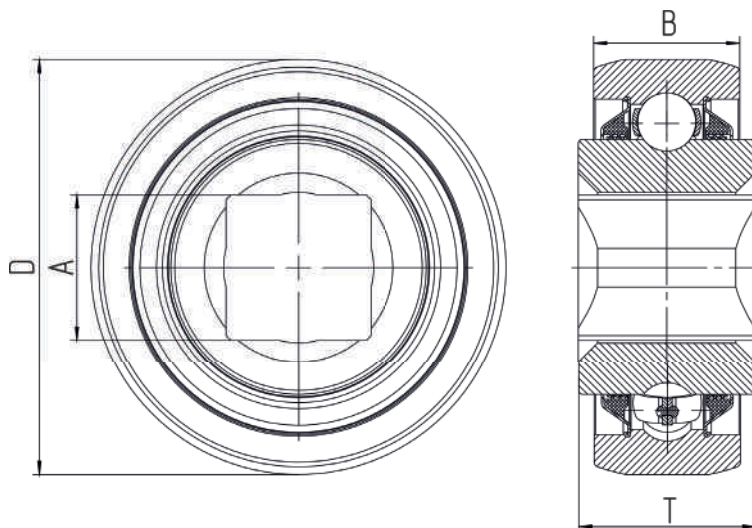

CROSS REFERENCE

Producer	OEM numbers
Timken	W208PPB12
BCA	DS208TT12
Link Belt	18S4-2E08E3
NTN	4AS08-1-1/8
Bush Hog	14-24-26
CNH	T28503
Eversman	266740
Lilliston	37-61-001
Massey Ferguson	447899M1

Designation BBC-R	Application	Bore type	Description	A	D	T	B
W208PPB12.LV	Gang disc – Relubricatable bearings	Square bore bearing	Tillage / Secondary tillage – Seedbed finisher	29,972	85,75	36,53	30,18

GW208PPB22.LV

CROSS REFERENCE

Producer	OEM numbers
Timken	GW208PPB22
NTN	SBX0887C4/L014
John Deere	AE48914

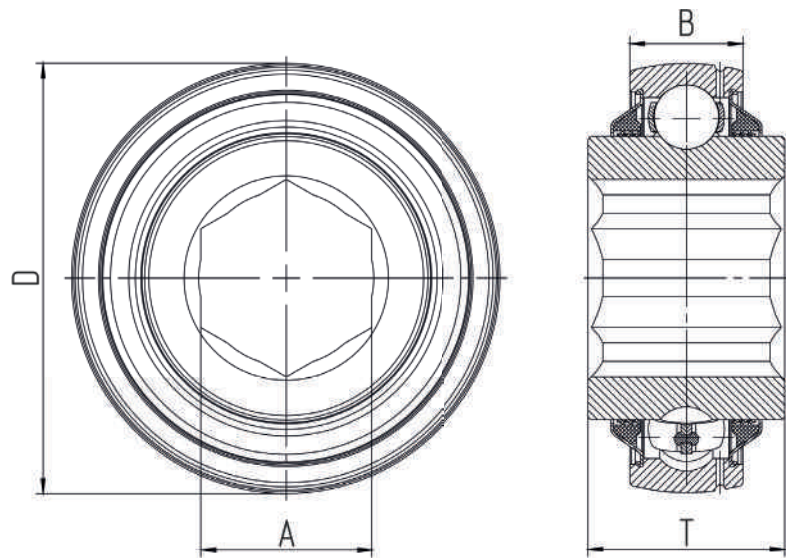

Designation BBC-R	Application	Bore type	Description	A	D	T	B
GW208PPB22.LV	Gang disc – Relubricatable bearings	Hexagonal bore bearing	Tillage / Secondary tillage – Seedbed finisher	31,877	80	36,53	21

GW208PPB5.LV

CROSS REFERENCE

Producer	OEM numbers
AMCO	G10212
CNH	184764A1
Federal Mogul	TNS208S1R
John Deere	A20175
Link Belt	18SG7-2E803
Newdep	RAS4508J
NTN	1AS8-1-5/32D1
Timken	GW208PPB5
NTN	DS 208 TTR5
White	213778B

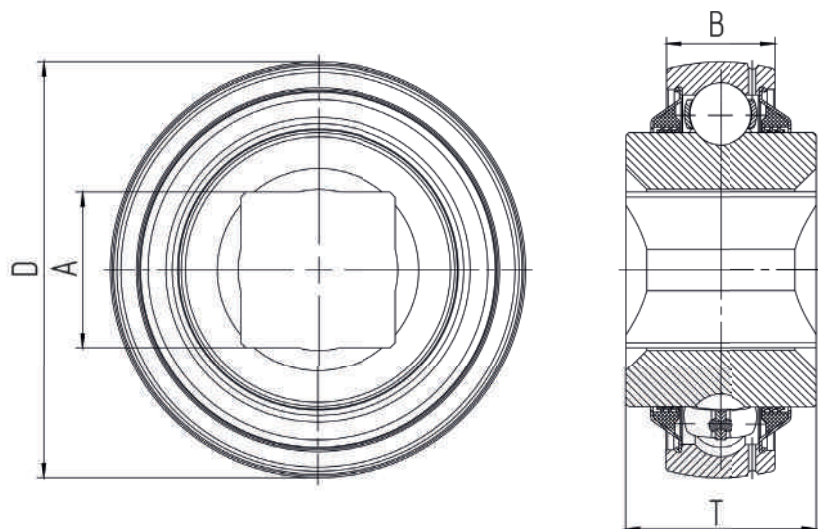

Designation BBC-R	Application	Bore type	Description	A	D	T	B
GW208PPB5.LV	Gang disc – Relubricatable bearings	Square bore bearing	Tillage / Secondary tillage – Seedbed finisher	28,575	80	36,525	21

GW208PPB8.LV

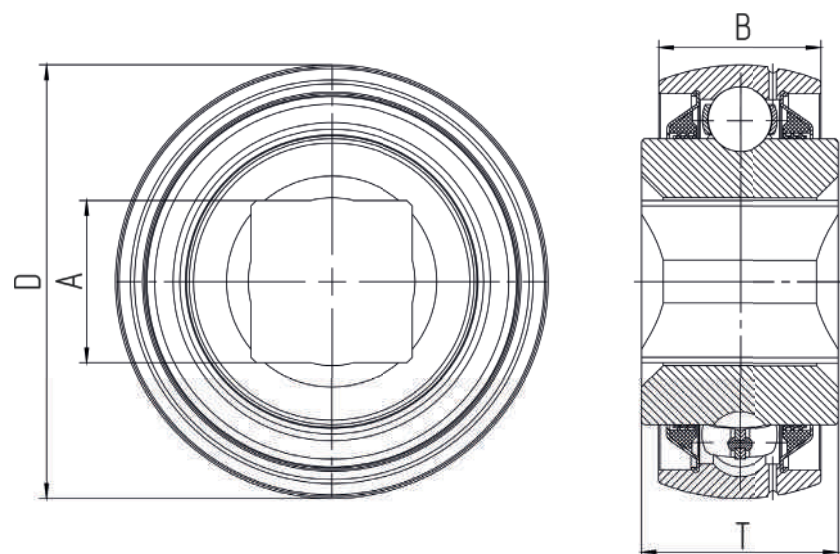

CROSS REFERENCE

Producer	OEM numbers
Timken	GW208PPB8
Taylor	207359
White	238481B
BCA	DS208TTR8
Federal Mogul	TS208S1R
NDH	RAS4508EF
Link Belt	18SG2-2E08E3
NTN	2AS08-1-1/8D1

Designation BBC-R	Application	Bore type	Description	A	D	T	B
GW208PPB8.LV	Gang disc – Relubricatable bearings	Square bore bearing	Tillage / Secondary tillage – Seedbed finisher	28,575	80	36,525	21

GW209PPB5.LV

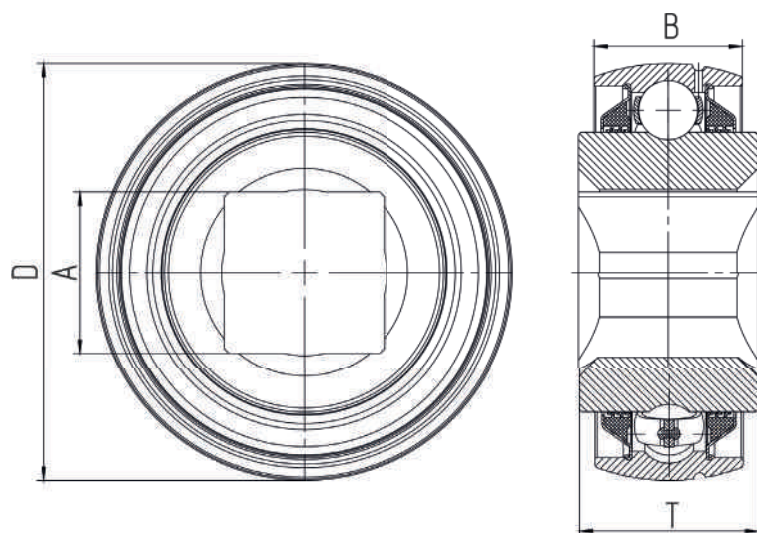

CROSS REFERENCE

Producer	OEM numbers
Timken	GW209PPB5
Massey Ferguson	842303M1
Massey Ferguson	842323M1
BCA	DS209TTR5
John Deere	JD8664
NDH	RAS4509A

Designation BBC-R	Application	Bore type	Description	A	D	T	B
GW209PPB5.LV	Gang disc – Relubricatable bearings	Square bore bearing	Tillage / Secondary tillage – Seedbed finisher	31,75	85	36,513	30,163

GW209PPB8.LV

CROSS REFERENCE

Producer	OEM numbers
Timken	GW209PPB8
Link Belt	18SG2-2E08E3
NTN	2AS08-1-1/8D1
National	DS209TTR8
NDH	RAS4508EF

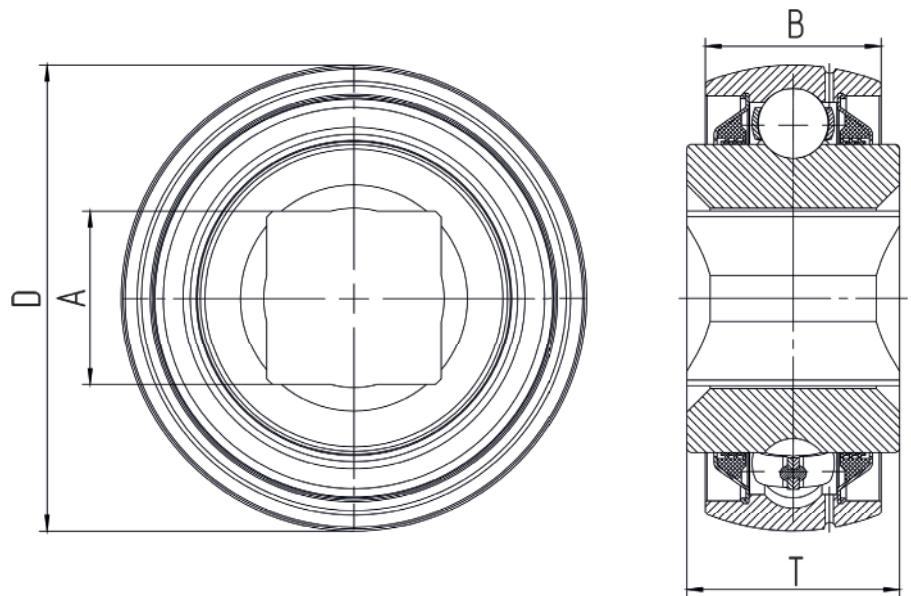

Designation BBC-R	Application	Bore type	Description	A	D	T	B
GW209PPB8.LV	Gang disc – Relubricatable bearings	Square bore bearing	Tillage / Secondary tillage – Seedbed finisher	31,75	85,000	36,513	22

W208PPB5.LV

CROSS REFERENCE

Producer	OEM numbers
Timken	W208PPB5
NTN	1AS081-1/8
Massey Ferguson	1905666M1
Massey Ferguson	PS01003
Sun Flower	24A5301S
CNH	630210R91
John Deere	JD9248

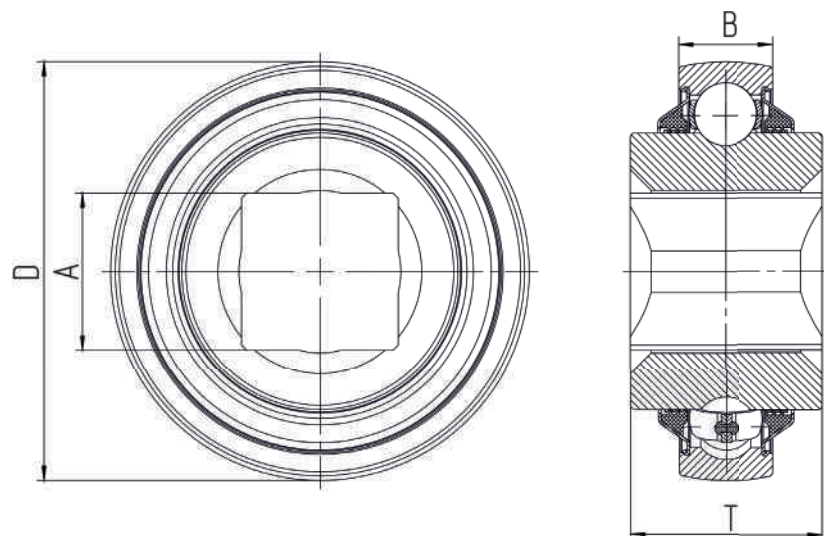

Designation BBC-R	Application	Bore type	Description	A	D	T	B
W208PPB5.LV	Gang disc – Non- relubricatable bearings	Square bore bearing	Tillage / Secondary tillage – Gang disc	28,575	80	36,513	18

W208PPB6.LV

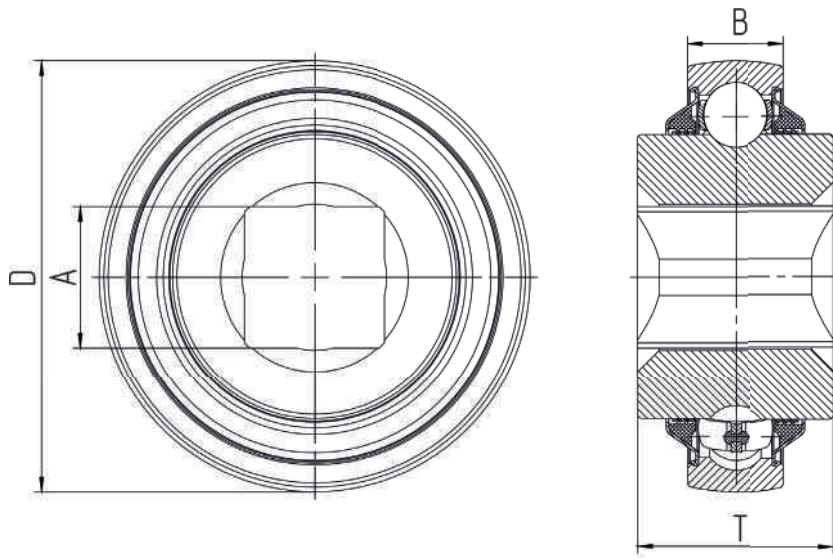

CROSS REFERENCE

Producer	OEM numbers
Timken	W208PPB6
AMCO	G11079
Bush Hog	14-22-63
Bush Hog	142263
Clark	6519831
CNH	1025130M1
CNH	834367M1
CNH	83436M1
CNH	NDAS4508FF
CNH	T15820
John Deere	JD10260
Link Belt	16S5-208E3
NDH	AS4508BK
NTN	1AS08-1
BCA	DS 208 TT6
White	20H5836

Designation BBC-R	Application	Bore type	Description	d	D	T	B
W208PPB6.LV	Gang disc – Non-relubricatable bearings	Square bore bearing	Tillage / Secondary tillage – Gang disc	25,4	80	36,513	18

W210PPB6.LV

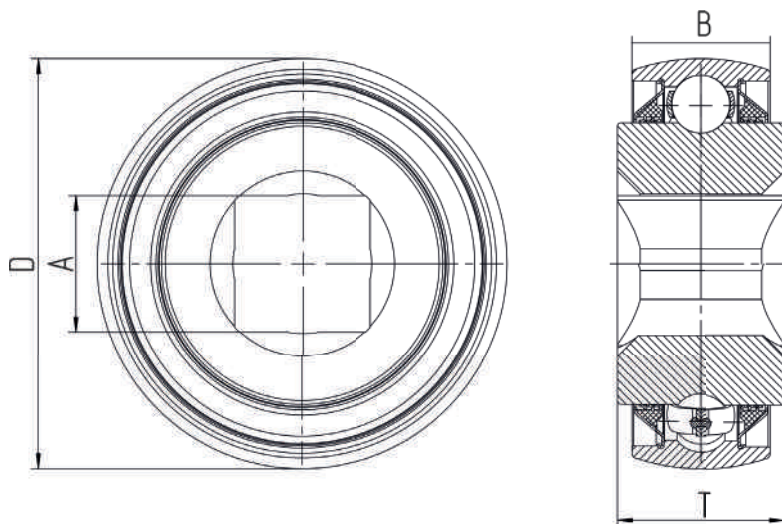

CROSS REFERENCE

Producer	OEM numbers
Timken	W210PPB6
BCA	DS210TT6
Link Belt	18S2-210E3
NTN	2AS10-1-1/8

Designation BBC-R	Application	Bore type	Description	A	D	T	B
W210PPB6.LV	Gang disc – Non-relubricatable bearings	Square bore bearing	Tillage / Secondary tillage – Gang disc	28,575	90	36,513	30,163

GW214PPB3.LV

CROSS REFERENCE

Producer	OEM numbers
Peer	GW214PPB3
Timken	GW 214 PPB3A4557
BCA	DS 214 TTR3
CNH	270061503
Wishek	12.31.339
AMKO	11504
Will Rich	1102-214

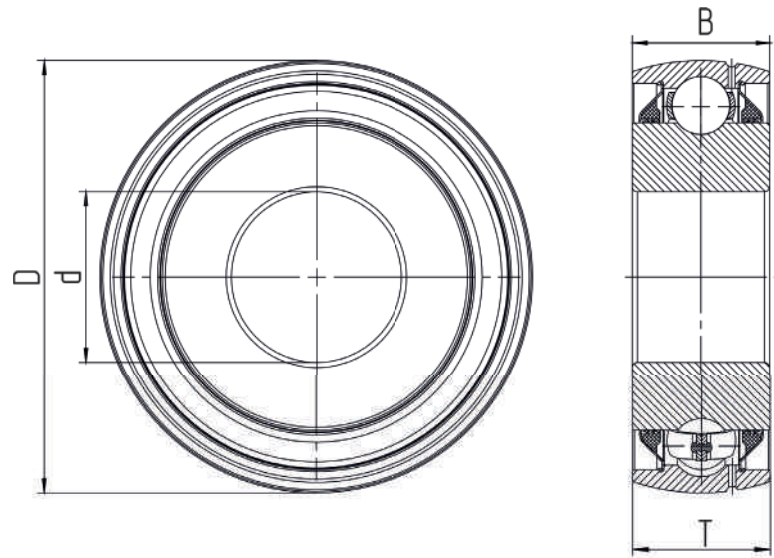

Designation BBC-R	Application	Bore type	Description	d	D	T	B
GW214PPB3.LV	Gang disc – Relubricatable bearings	Round bore bearing	Tillage / Secondary tillage – Gang disc	49,225	125	39,675	39,675

GW209PPB2.LV

CROSS REFERENCE

Producer	OEM numbers
Timken	GW209PPB2
Burch	208-12
Ford	7200460
Pittsburgh	FG-40485
BCA	DS209TTR2
NDH	RAS4509BE

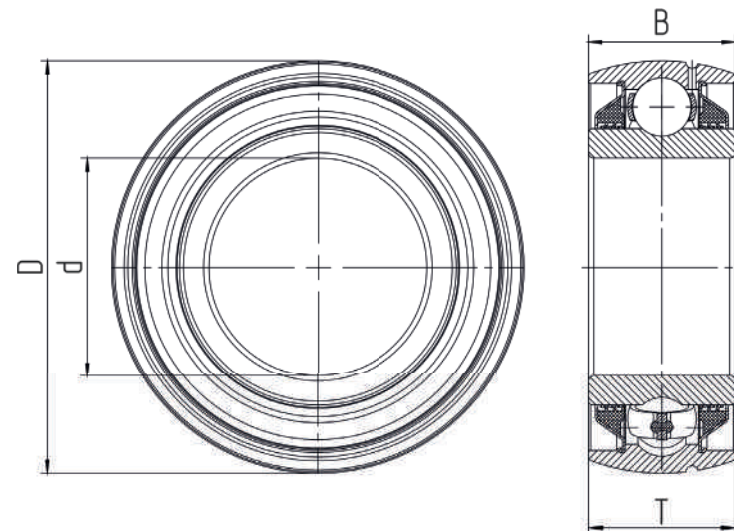

Designation BBC-R	Application	Bore type	Description	d	D	T	B
GW209PPB2.LV	Gang disc – Relubricatable bearings	Round bore bearing	Tillage / Secondary tillage – Seedbed finisher	45	85	30	30

GW209PPB4.LV

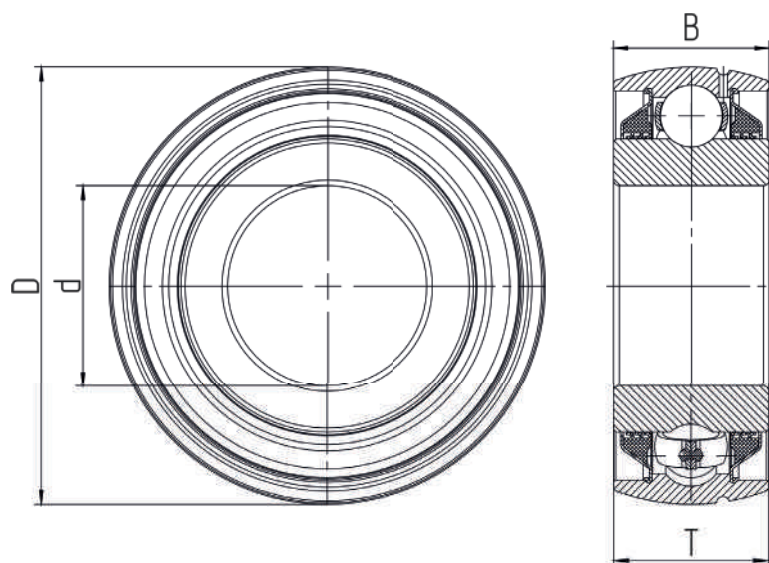

CROSS REFERENCE

Producer	OEM numbers
Timken	GW209PPB4
NTN	3AC09-1-1/2D1
Krause	612102
John Deere	AN240220
BCA	DS209TTR4
NDH	RAS4509BD
CNH	T57851
Federal Mogul	TWS209AR
NTN	DS 209 TTR4

Designation BBC-R	Application	Bore type	Description	d	D	T	B
GW209PPB4.LV	Gang disc – Relubricatable bearings	Round bore bearing	Tillage / Secondary tillage – Seedbed finisher	39	85	30,163	30,163

W209PPB2.LV

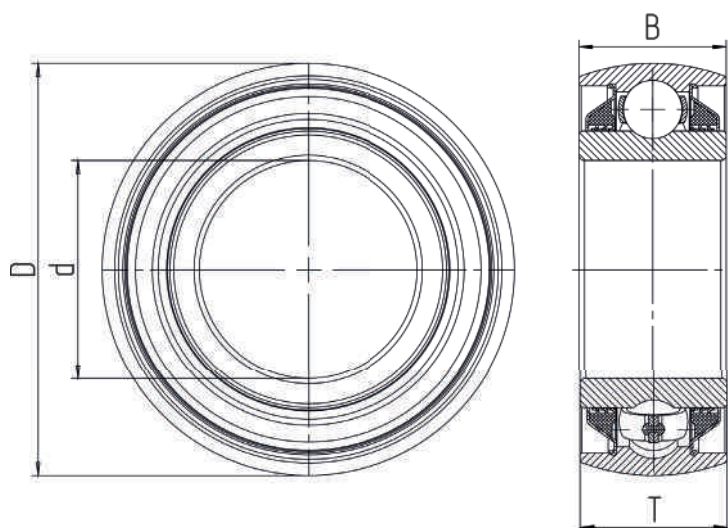

CROSS REFERENCE

Producer	OEM numbers
Timken	W209PPB2
CNH	251062C91
CNH	9808111
Massey Ferguson	835050M1
BCA	DS 209 TT2

Designation BBC-R	Application	Bore type	Description	d	D	T	B
W209PPB2.LV	Gang disc – Non-relubricatable bearings	Round bore bearing	Tillage / Secondary tillage – Gang disc	45	85	30,163	30,163

W210PPB2.LV

CROSS REFERENCE

Producer	OEM numbers
Timken	W210PPB2
BCA	DS210TT2
Link Belt	31R3-210E3
NTN	3AC10-1-15/16
Massey Ferguson	831960M3
FarmHand	10771
Bush Hog	14-5-109

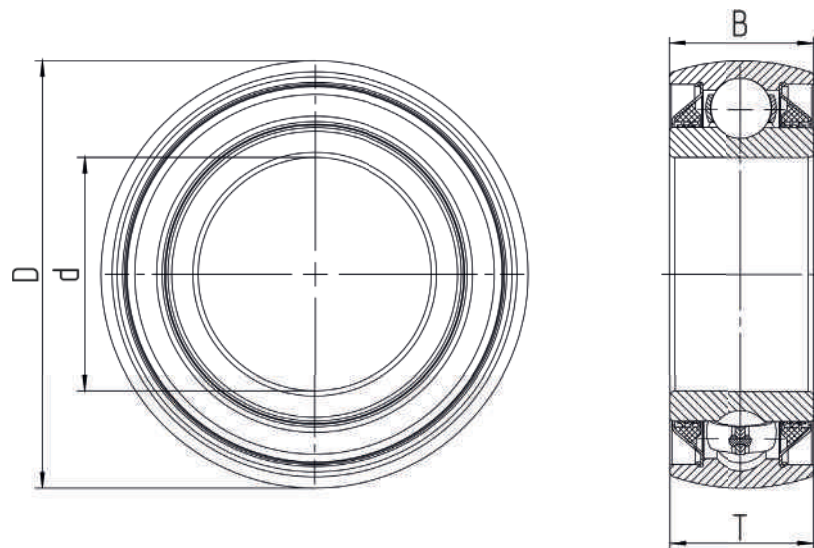

Designation BBC-R	Application	Bore type	Description	d	D	T	B
W210PPB2.LV	Gang disc – Non-relubricatable bearings	Round bore bearing	Tillage / Secondary tillage – Gang disc	49,225	90	30,163	30,163

W211PPB2.LV

CROSS REFERENCE

Producer	OEM numbers
Timken	W211PPB2
BCA	DS211TT2
Link Belt	35R3-211E3
NTN	3AC11-2-3/16
CNH	T57559
CNH	H747170
CNH	958334R91
Will Rich	24022
Bush Hog	14-6-168
Clark	6517957
Federal Mogul	TWS211A

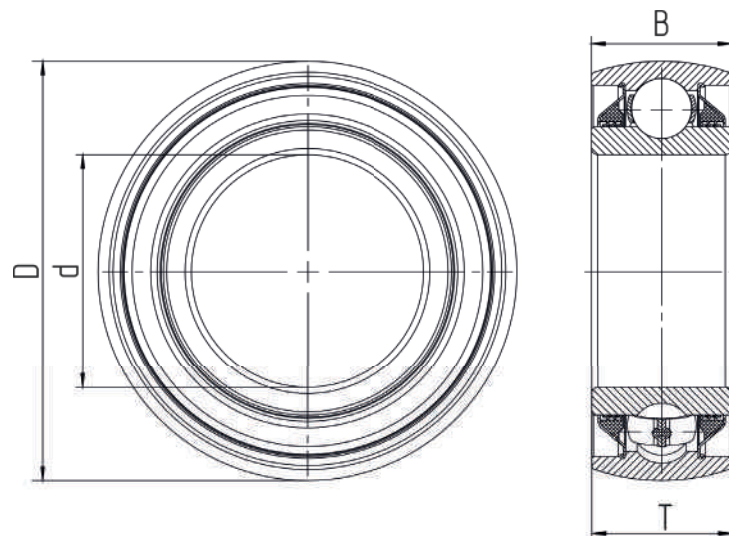

Designation BBC-R	Application	Bore type	Description	d	D	T	B
W211PPB2.LV	Gang disc – Non-relubricatable bearings	Round bore bearing	Tillage / Secondary tillage – Gang disc	55,575	100	33,338	33,338

232812.LV

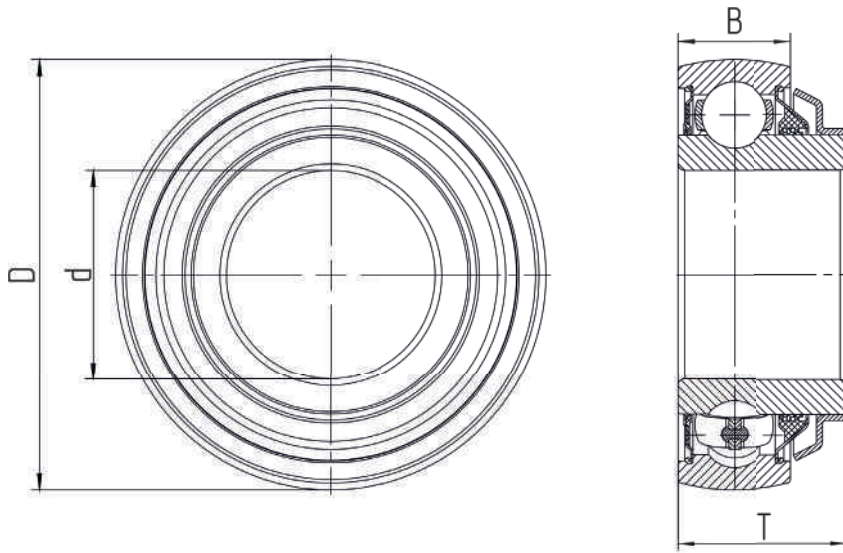

CROSS REFERENCE

Producer	OEM numbers
INA	F-232812-0200
FKL	LS 207-TBS
SKF if it possible	YFE207-2F
SKF if it possible	446207D
SKF if it possible	YELAG207
SKF if it possible	YEL207-2RF/VL065
SKF if it possible	YEL207
FAG if it possible	36207
INA if it possible	GE35KRRB
Fafnir if it possible	GE35KRRB
HFH if it possible	A207

Designation BBC-R	Application	Bore type	Description	d	D	T	B
232812.LV	Rubber ring roller	Round bore bearing	Tillage / Secondary tillage – Seedbed finisher	35	72	28,4	19

GW211PP17.LV

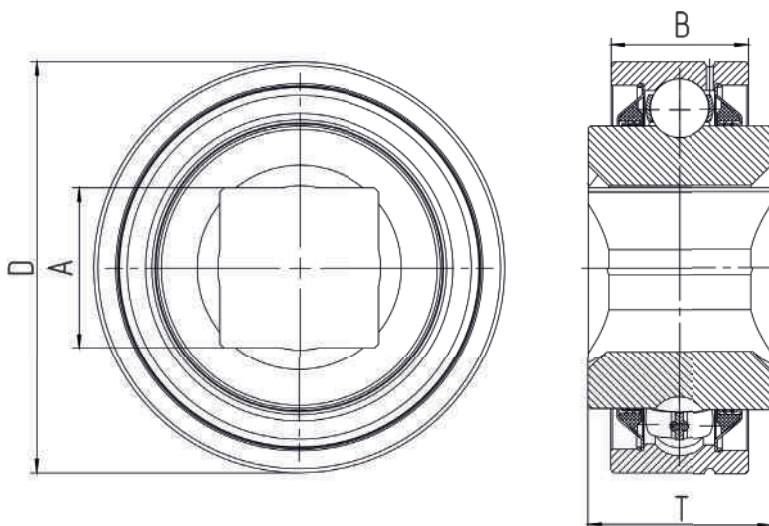

CROSS REFERENCE

Producer	OEM numbers
Timken	GW211PP17
Timken bearing unit	GW211PP17-HDT-211-H
BCA	DC211TTR13
Will Rich	WR24099
Will Rich bearing unit	24155
Will Rich	242594
Will Rich bearing unit	24306

Designation BBC-R	Application	Bore type	Description	d	D	T	B
GW211PP17.LV	Gang disc – Relubricatable bearings	Square bore bearing	Tillage / Secondary tillage – Gang disc	38,1	100	44,450	33,340

GW209PPB11.LV

CROSS REFERENCE

Producer	OEM numbers
Timken John Deere BCA	GW209PPB11 A20649 DS209TTR10

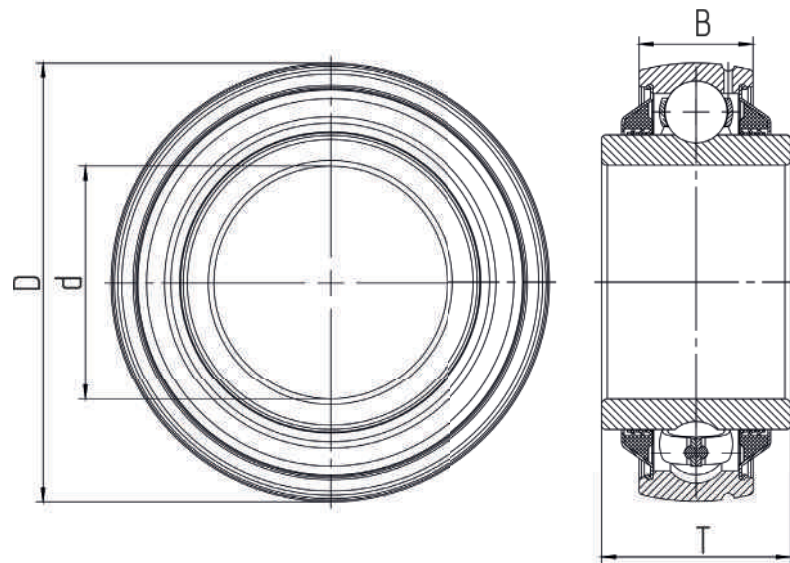

Designation BBC-R	Application	Bore type	Description	d	D	T	B
GW209PPB11.LV	Gang disc – Relubricatable bearings	Round bore bearing	Tillage / Secondary tillage – Seedbed finisher	45,237	85	36,525	22

GW211PPB13.LV

CROSS REFERENCE

Producer	OEM numbers
Timken Sun Flower John Deere BCA Massey Ferguson NTN NTN AGCO	GW211PPB13 20-42 (2042) AN240221 DS211TTR13 PS01041 SBX1152C4 SBX1181LLSQ1 SN2042

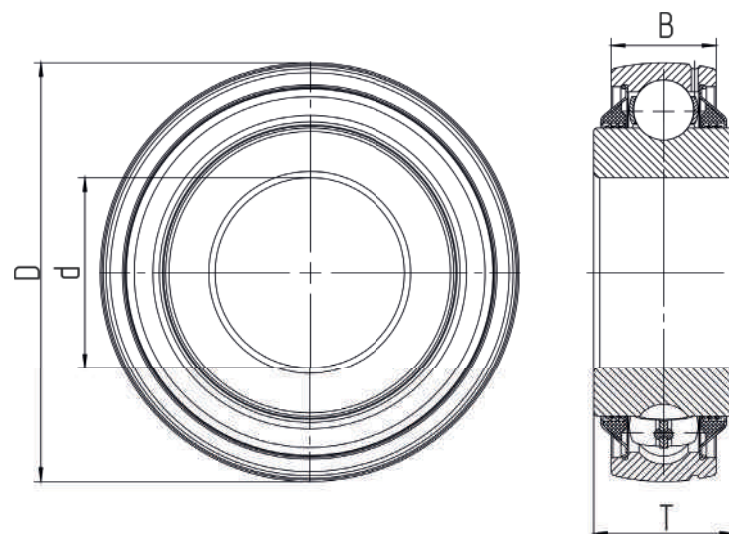

Designation BBC-R	Application	Bore type	Description	d	D	T	B
GW211PPB13.LV	Gang disc – Relubricatable bearings	Round bore bearing	Tillage / Secondary tillage – Seedbed finisher	45	100	33,325	25

GW211PPB14.LV

CROSS REFERENCE

Producer

Timken
BCA

OEM numbers

GW211PPB14
DS211TTRF

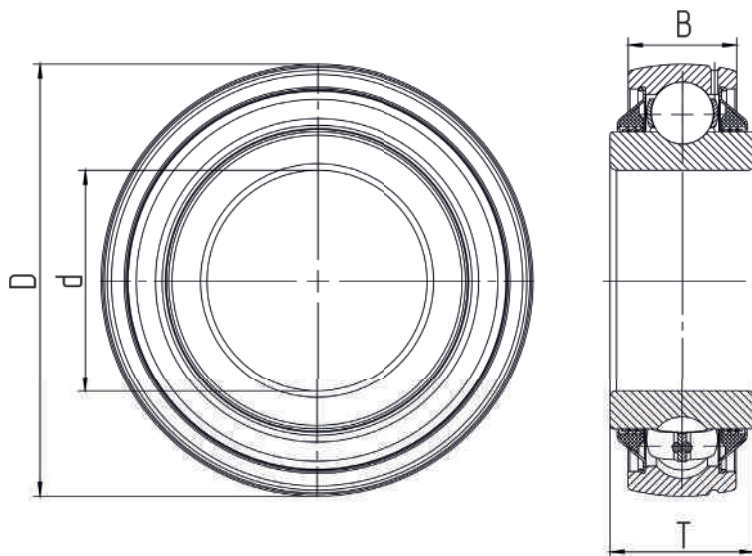

Designation BBC-R	Application	Bore type	Description	d	D	T	B
GW211PPB14.LV	Gang disc – Relubricatable bearings	Round bore bearing	Tillage / Secondary tillage – Seedbed finisher	51,181	100	33,325	25

GW211PPB9.LV

CROSS REFERENCE

Producer

Timken
John Deere

OEM numbers

GW211PPB9
B34215

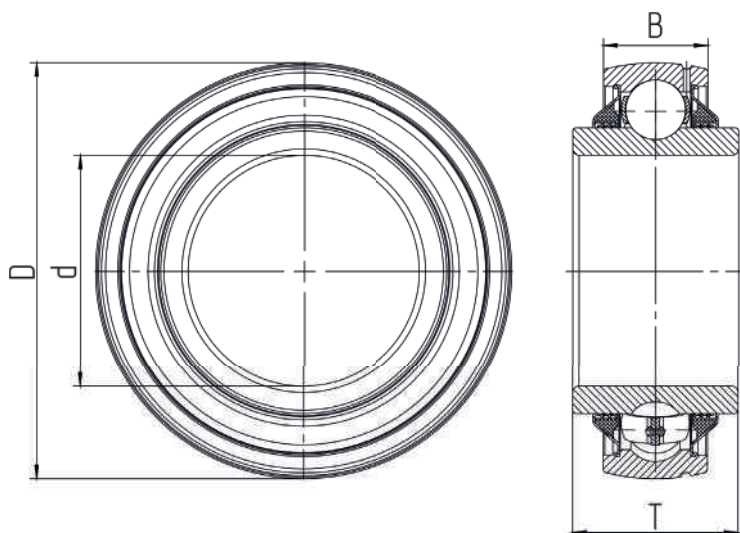

Designation BBC-R	Application	Bore type	Description	d	D	T	B
GW211PPB9.LV	Gang disc – Relubricatable bearings	Round bore bearing	Tillage / Secondary tillage – Seedbed finisher	55,575	100	39,675	25

GW214PPB5.LV

CROSS REFERENCE

Producer	OEM numbers
Timken	GW214PPB5
CNH	60249C91
BCA	DS214TTR5

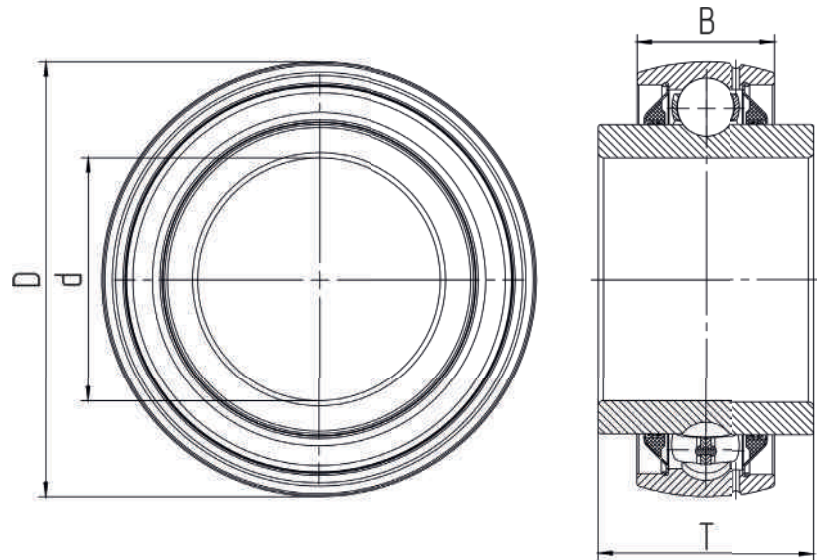

Designation BBC-R	Application	Bore type	Description	d	D	T	B
GW214PPB5.LV	Gang disc – Relubricatable bearings	Round bore bearing	Tillage / Secondary tillage – Seedbed finisher	70	125	61,925	39,675

W208PPB2.LV

CROSS REFERENCE

Producer	OEM numbers
Timken	W208PPB2
BCA	DS208TT2A
Link Belt	24R6-208E3
NTN	2AC08-1-1/2
John Deere	AW20540
AGCO	832634M3
AGCO	1905664M1
AGCO	831110M1
CNH	87446550

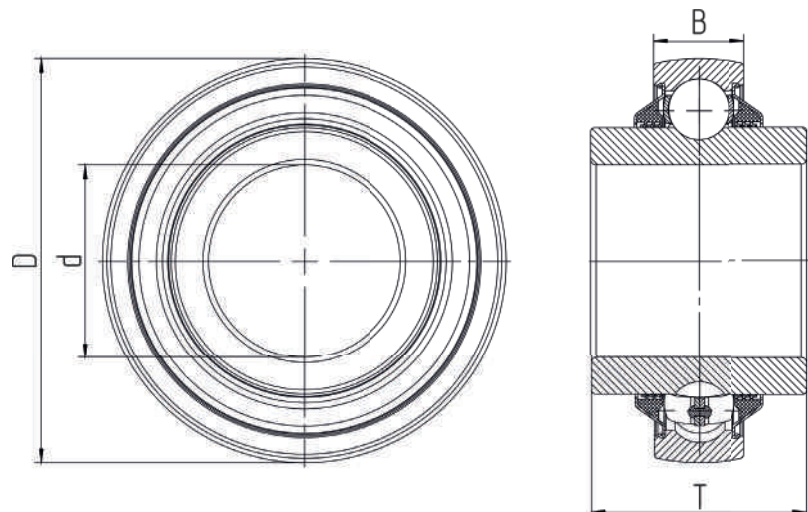

Designation BBC-R	Application	Bore type	Description	d	D	T	B
W208PPB2.LV	Gang disc – Non-relubricatable bearings	Round bore bearing	Tillage / Secondary tillage – Gang disc	38,1	80	42,863	18

GW210PPB4.LV

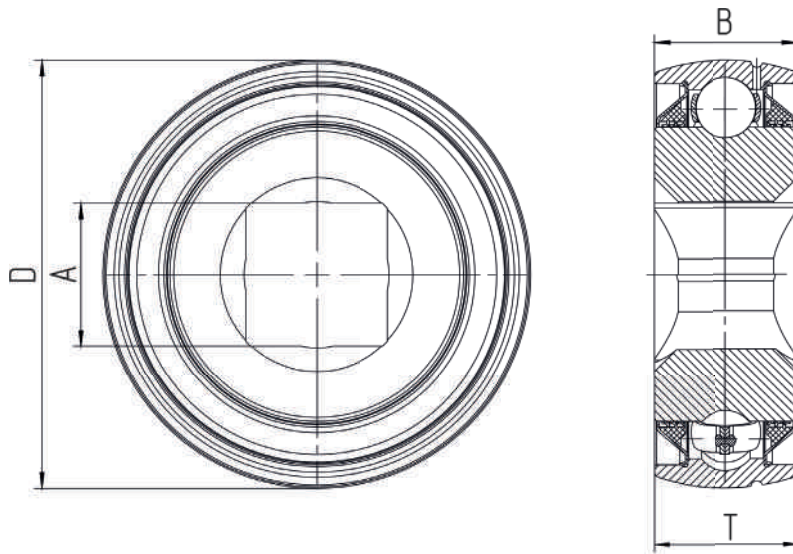

CROSS REFERENCE

Producer	OEM numbers
Timken	GW210PPB4
Link Belt	18SG3-210E3
NTN	3AS10-1-1/8D1
Kewanee	B2246
BCA	DS210TTR4
Koyo	G45102TR18S
John Deere	PMDS210TTR4
Newdep	RAS4510F
SKF	YQN210-102B4G

Designation BBC-R	Application	Bore type	Description	A	D	T	B
GW210PPB4.LV	Gang disc – Relubricatable bearings	Square bore bearing	Tillage / Secondary tillage – Seedbed finisher	28,575	90	30,163	30,163

GW211PPB3.LV

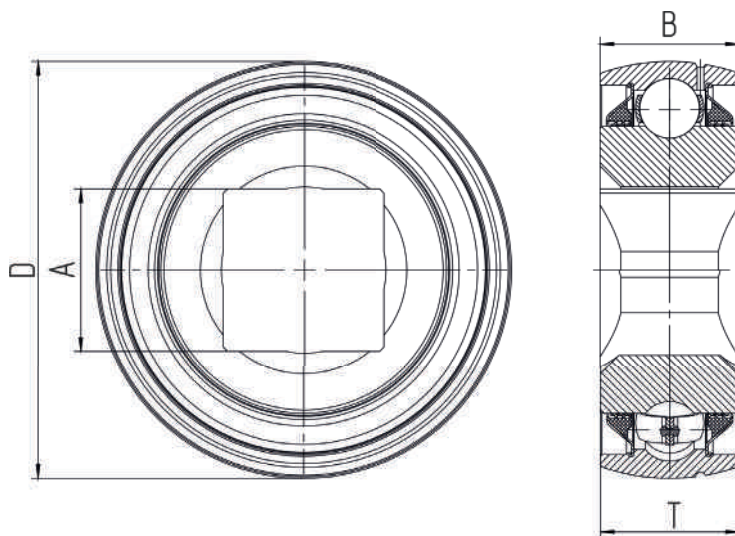

CROSS REFERENCE

Producer	OEM numbers
Timken	GW211PPB3
Burch	203214
Taylor	207022
White	237909B
NTN	3AS111-1/2D1
Massey Ferguson	449432M1
Massey Ferguson	PS01029
CNH	630095R91
CNH	T51610
Allis Chalmers	70583939
Allis Chalmers	G10906
McFarlane	RT2274
John Deere	PMDS211TTR3
NDH	RAS4511BE
Federal Mogul	TWS211S4R
NTN	3AS11-1-1/2D1
BCA	DS 211 TTR3

Designation BBC-R	Application	Bore type	Description	A	D	T	B
GW211PPB3.LV	Gang disc – Relubricatable bearings	Square bore bearing	Tillage / Secondary tillage – Seedbed finisher	38,1	100	33,325	33,325

GW211PP2.LV

CROSS REFERENCE

Producer	OEM numbers
Timken	GW211PP2
NDH	RAS4511C
Bush Hog	14-6-244
Kewanee	B2289
BCA	DC211TTR2

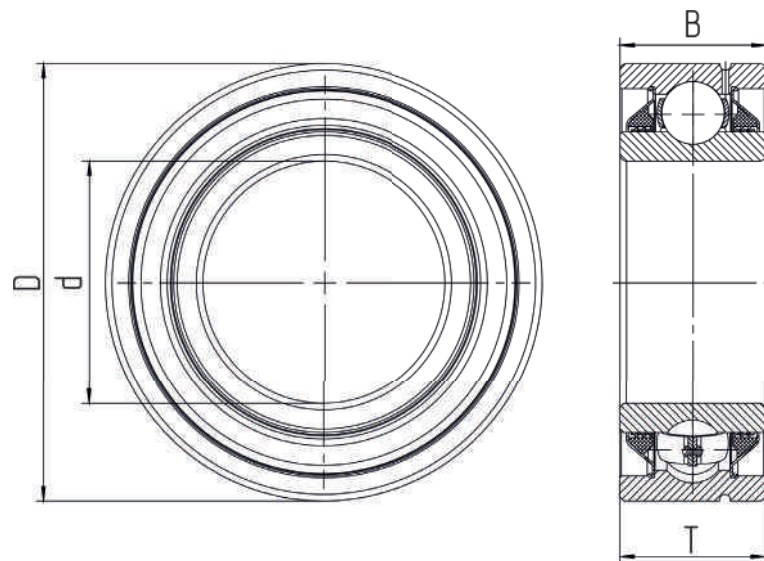

Designation BBC-R	Application	Bore type	Description	A	D	T	B
GW211PP2.LV	Gang disc – Relubricatable bearings	Round bore bearing	Tillage / Secondary tillage – Seedbed finisher	55,575	100	33,338	33,338

W211PPB3.LV

CROSS REFERENCE

Producer	OEM numbers
Timken	W211PPB3
BCA	DS211TT3
Link Belt	24S3-211E3
NTN	3AS11-1-1/2

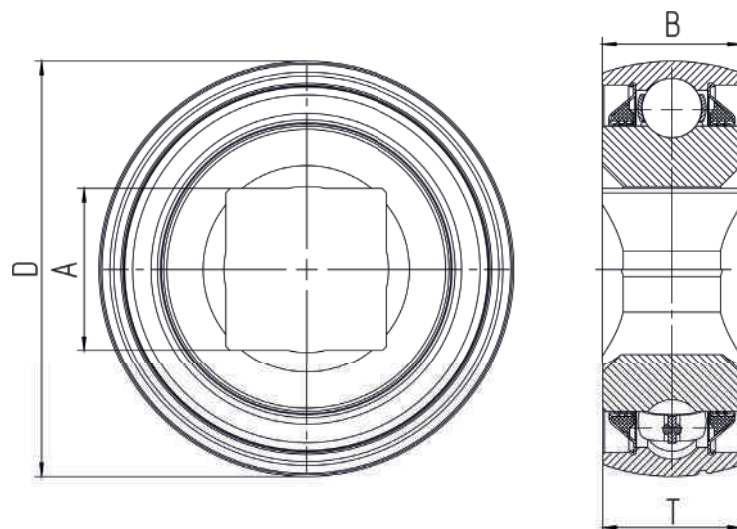

Designation BBC-R	Application	Bore type	Description	A	D	T	B
W211PPB3.LV	Gang disc – Non-relubricatable bearings	Square bore bearing	Tillage / Secondary tillage – Gang disc	38,1	100	33,338	33,338

W209PPB6.LV

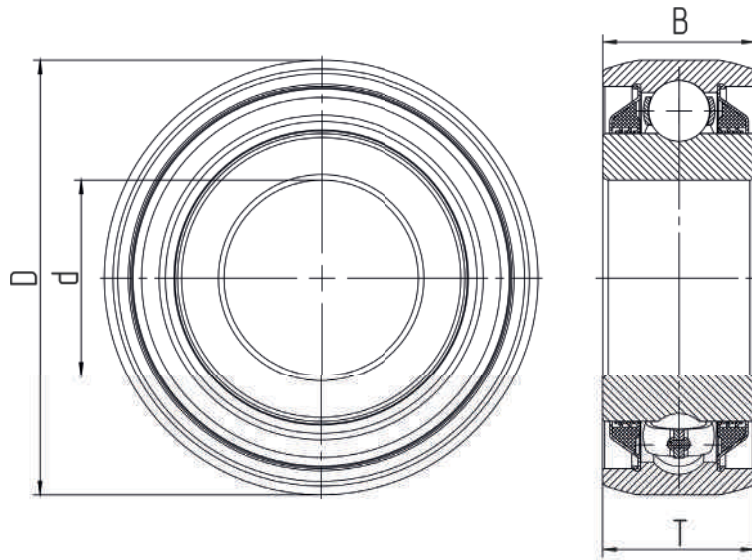

CROSS REFERENCE

Producer	OEM numbers
Timken BCA Link Belt NDH	W209PPB6 DS209TT6 24R-209E3 AS4509B

Designation BBC-R	Application	Bore type	Description	d	D	T	B
W209PPB6.LV	Gang disc – Non-relubricatable bearings	Round bore bearing	Tillage / Secondary tillage – Gang disc	38,735	85,75	30,163	30,163

W210PP2.LV

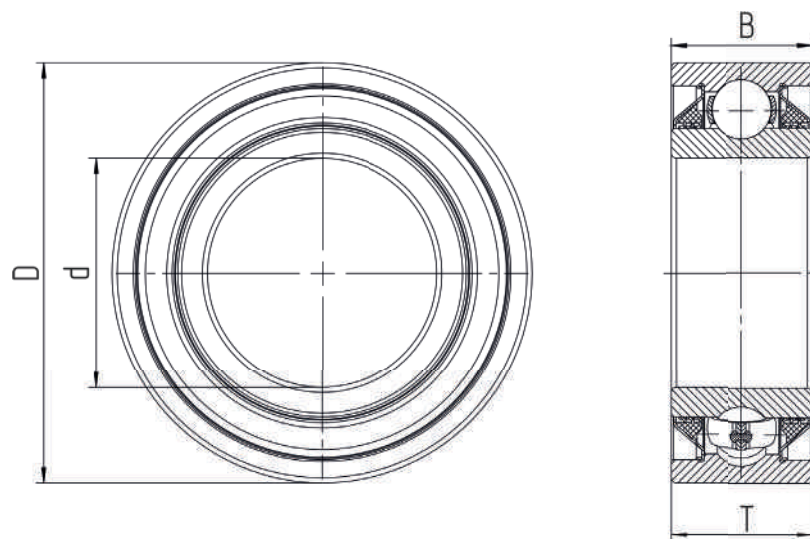

CROSS REFERENCE

Producer	OEM numbers
Timken BCA NDH NTN	W210PP2 DC210TT2 31RB3-210E3 7AC10-1-15/16

Designation BBC-R	Application	Bore type	Description	d	D	T	B
W210PP2.LV	Gang disc – Non-relubricatable bearings	Round bore bearing	Tillage / Secondary tillage – Gang disc	49,225	90	30,163	30,163

W211PP2.LV

CROSS REFERENCE

Producer	OEM numbers
Timken	W211PP2
BCA	DC211TT2
CNH	H747394
Federal Mogul	TW211A
NDH	AS4511C

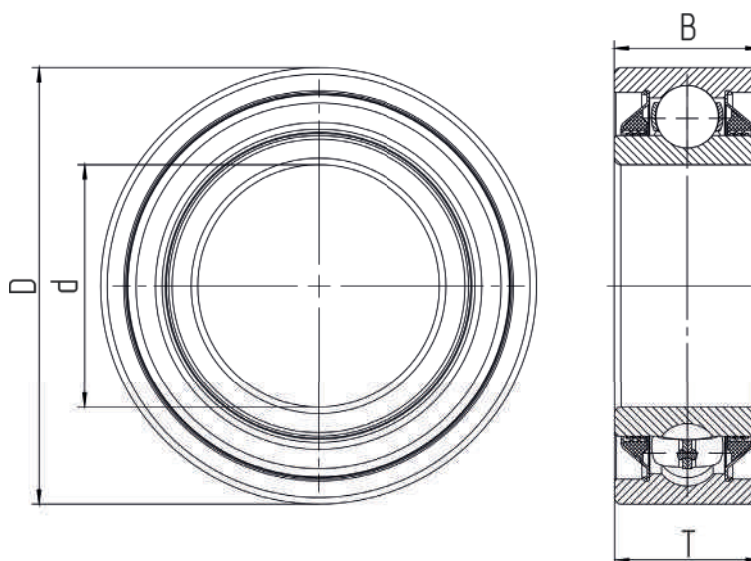

Designation BBC-R	Application	Bore type	Description	d	D	T	B
W211PP2.LV	Gang disc – Non-relubricatable bearings	Round bore bearing	Tillage / Secondary tillage – Gang disc	55,575	100	33,338	33,338

GW211PP25.LV

CROSS REFERENCE

Producer	OEM numbers
Timken	GW211PP25
Timken Bearing Unit	GW211PP25-HDT-211-H
FKL Bearing Unit	GWHG211PP25
Peer Bearing Unit	HDT 1 3/4 RD
KABAT Bearing Unit	P3090
Sun Flower bearing unit	SN3090
Peer	HDT 1 3/4 RD

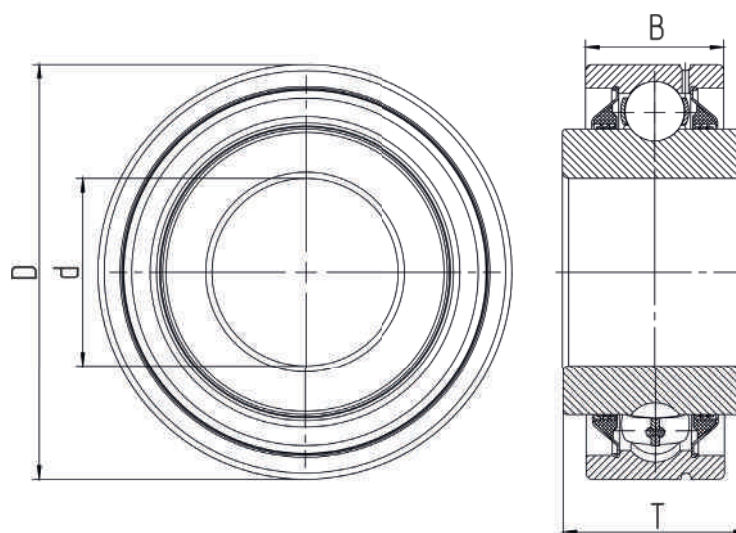

Designation BBC-R	Application	Bore type	Description	d	D	T	B
GW211PP25.LV	Gang disc – Relubricatable bearings	Round bore bearing	Tillage / Secondary tillage – Seedbed finisher	45,212	100	44,45	33,325

W211PPB4.LV

CROSS REFERENCE

Producer

Timken

OEM numbers

W211PPB4

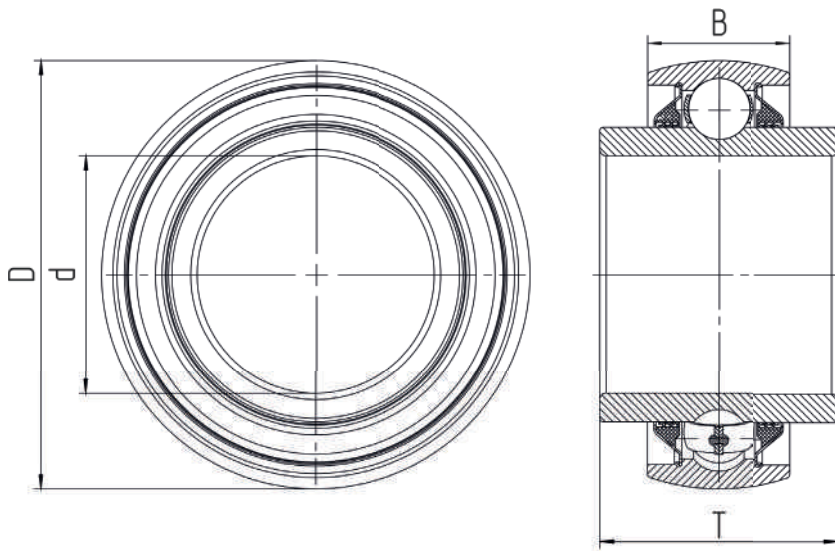

Designation BBC-R	Application	Bore type	Description	d	D	T	B
W211PPB4.LV	Gang disc – Non-relubricatable bearings	Round bore bearing	Tillage / Secondary tillage – Gang disc	55,575	100	55,56	33,338

GW211PP3.LV

CROSS REFERENCE

Producer

Timken
Bush Hog
Allis Chalmers
NTN
CNH
CNH
AMCO

OEM numbers

GW211PP3
146430
5944913
7AS11-1-1/2D1
T51653
G11071
RAS4511BD

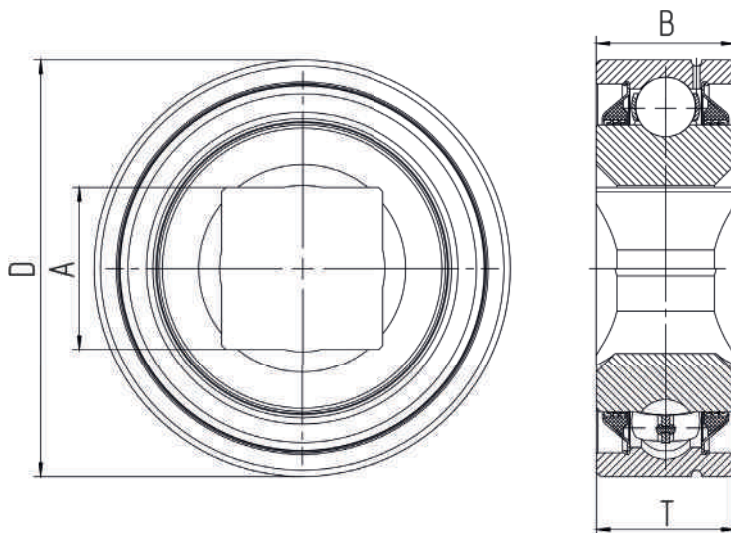

Designation BBC-R	Application	Bore type	Description	A	D	T	B
GW211PP3.LV	Gang disc – Relubricatable bearings	Square bore bearing	Tillage / Secondary tillage – Seedbed finisher	38,1	100	33,325	33,325

CROSS REFERENCE

Producer	OEM numbers
Timken	W211PP3
BCA	DC211TT3
NHD	24SB3-211E3
AMCO	G11071
Bush Hog	203214
FARMHAND	7377-1
FORD	MULCB112SG
CNH	630095R91
CNH	232468
Massey Ferguson	1905678M1
Massey Ferguson	6510628
Clark	TW211S4

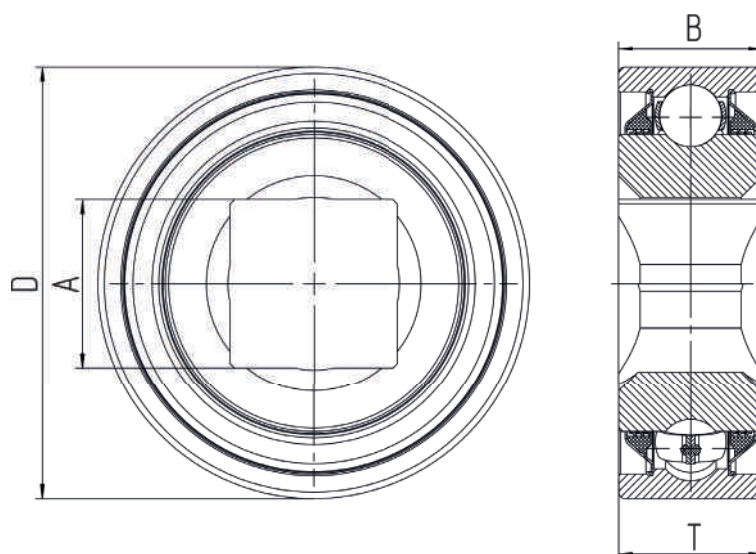

Designation BBC-R	Application	Bore type	Description	A	D	T	B
W211PP3.LV	Gang disc – Non-relubricatable bearings	Square bore bearing	Tillage / Secondary tillage – Gang disc	38,1	100	33,338	33,338

CROSS REFERENCE

Producer	OEM numbers
Timken	GW211PPB21-BR211RH
FKL	GWR211PPB21
Great Plains	822-026C
Krause	2410110
rubber coated unit	
Krause	2410-11-0
rubber coated unit	
Krause	40173
just bearing	
Krause	40-173
just bearing	
BCA	CDS211TTR23N
NTN	CDS211TTR25
Kuhn	Q4008360

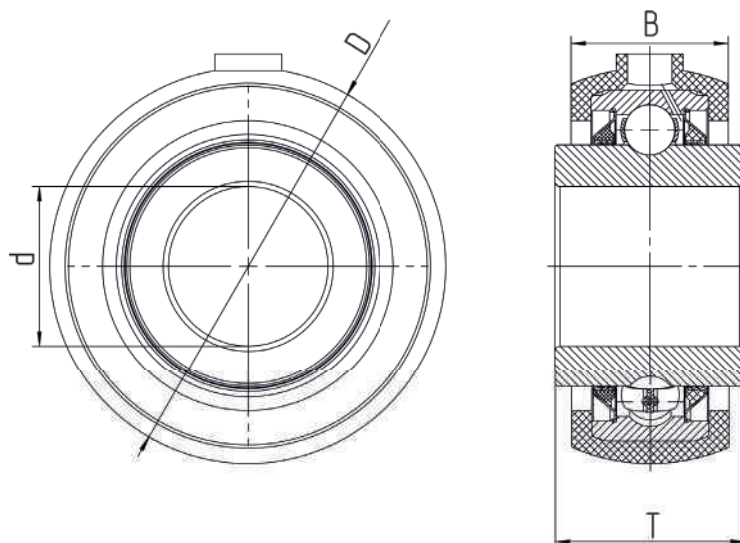

Designation BBC-R	Application	Bore type	Description	d	D	T	B
GWR211PPB21.LV	Gang disc – Relubricatable bearing unit	Round bore bearing	Tillage / Secondary tillage – Seedbed finisher	45,212	113	53,975	44,7

GWR209PPB30.LV

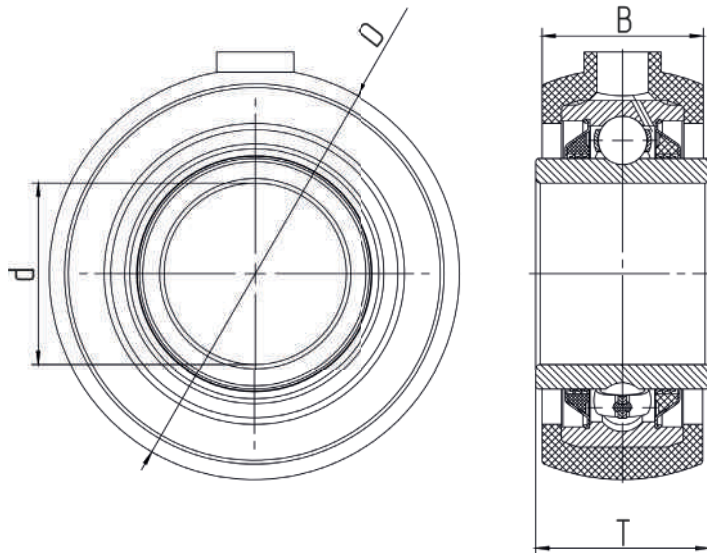

CROSS REFERENCE

Producer	OEM numbers
Timken	GW209PPB23 BR209RH
FKL	GWR209PPB30
Kuhn	Q4008350
Krause	40-167
Krause	40167
Kabat	1927-11-0
Farm Parts	P1927110
BCA	CDS209TTR6PA

Designation BBC-R	Application	Bore type	Description	d	D	T	B
GWR209PPB30.LV	Gang disc – Relubricatable bearing unit	Round bore bearing	Tillage / Secondary tillage – Seedbed finisher	44,5	101,6	43	40

28071300.LV

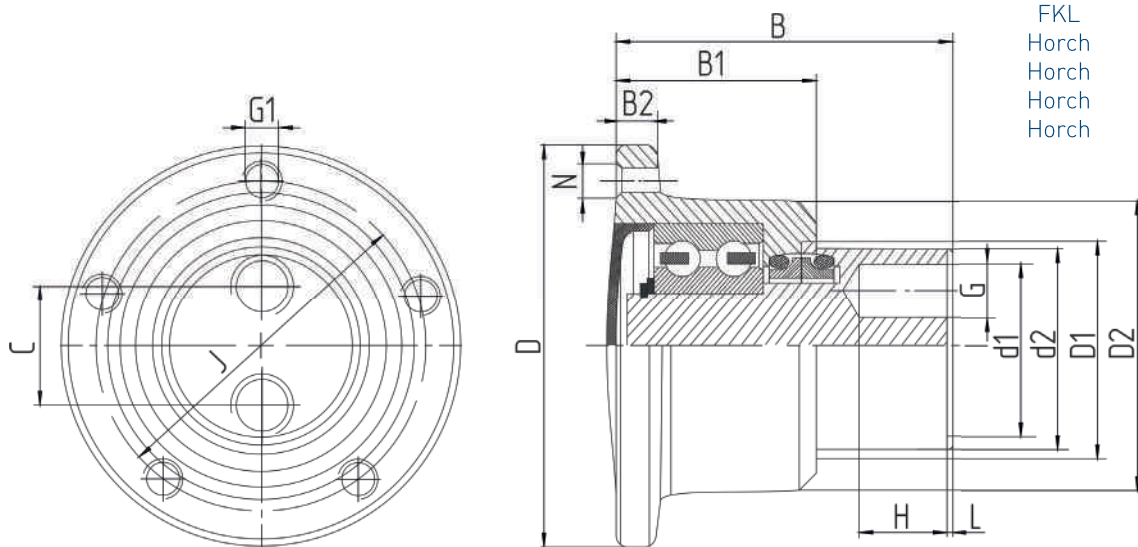

CROSS REFERENCE

Producer	OEM numbers
FKL	PL-127
Horch	28071300
Horch	28085600
Horch	28077800
Horch	28077900

Designation BBC-R	Application	Description	Seal type	D	D1	D2	d1	d2	J	H	L
28071300.LV	Independent tillage disc – Agro Hub	Tillage / Secondary tillage – Independent tillage disc	Disc diameter up to 550	127,3	69,5	90,4	55,7	64,2	106	25	2
				B	B1	B2	N	G1	G	C	
				106,5	63,5	13	13	M12	M20	C8	

DHU 1 1/2 R209.LV

CROSS REFERENCE

Producer

OEM numbers

Timken

DHU 1 1/2 R209

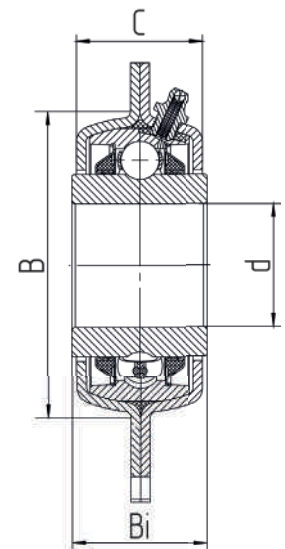
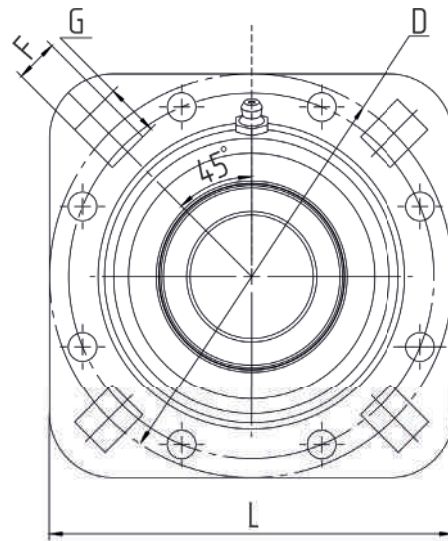

Designation BBC-R	Application	Bore type	Description	A/d	Bi	L	D bolt circle	E
DHU 1 1/2 R209.LV	Seedbed finisher – Flanged disc	Round bore bearing	Tillage / Secondary tillage – Seedbed finisher	38,7	42,8	127	127	-
				F	G	B min frame opening	C	
				13,5	17,6	98	42	

DHU 1 1/8 S209.LV

CROSS REFERENCE

Producer

OEM numbers

Timken

DHU 1 1/8 S209

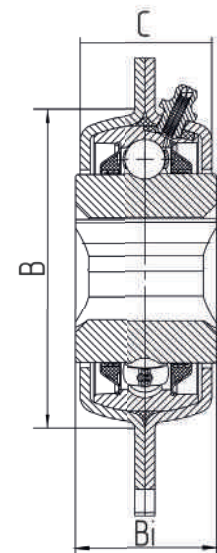
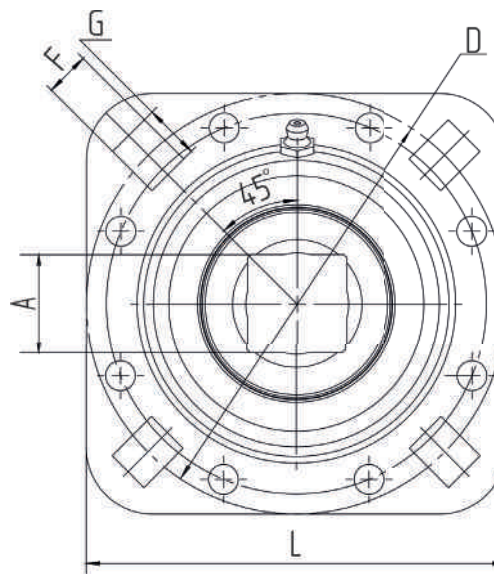

Designation BBC-R	Application	Bore type	Description	A/d	Bi	L	D bolt circle	E
DHU 1 1/8 S209.LV	Seedbed finisher – Flanged disc	Square bore bearing	Tillage / Secondary tillage – Seedbed finisher	29,972	42,8	127	127	-
				F	G	B	C	
				13,5	17,6	98	42	

DHU 1 1/4 S209.LV

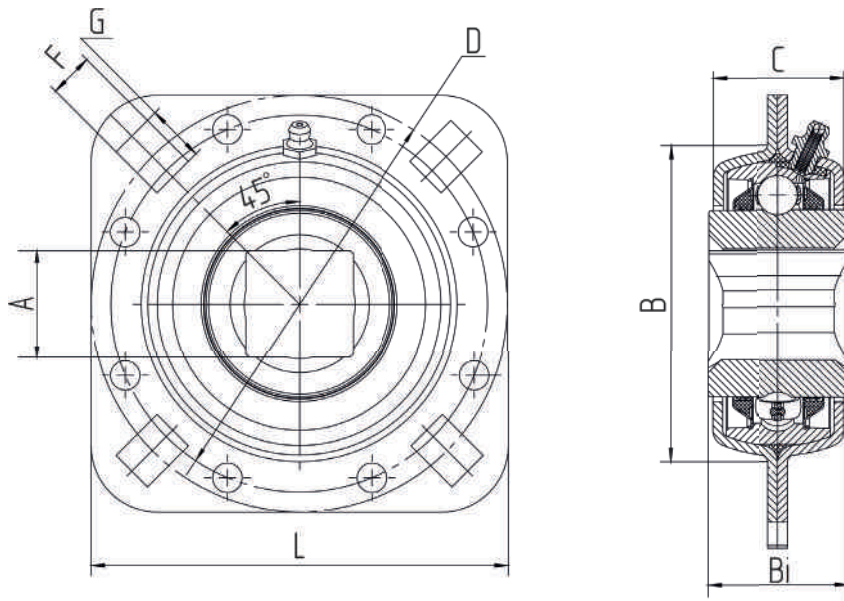

CROSS REFERENCE

Producer	OEM numbers
Timken	DHU 1 1/4 S209

Designation BBC-R	Application	Bore type	Description	A/d	Bi	L	D bolt circle	E
DHU 1 1/4 S209.LV	Seedbed finisher – Flanged disc	Square bore bearing	Tillage / Secondary tillage – Seedbed finisher	32,77	42,8	127	127	-
				F	G	B	C	
				13,5	17,6	98	42	

DHU 491A.LV

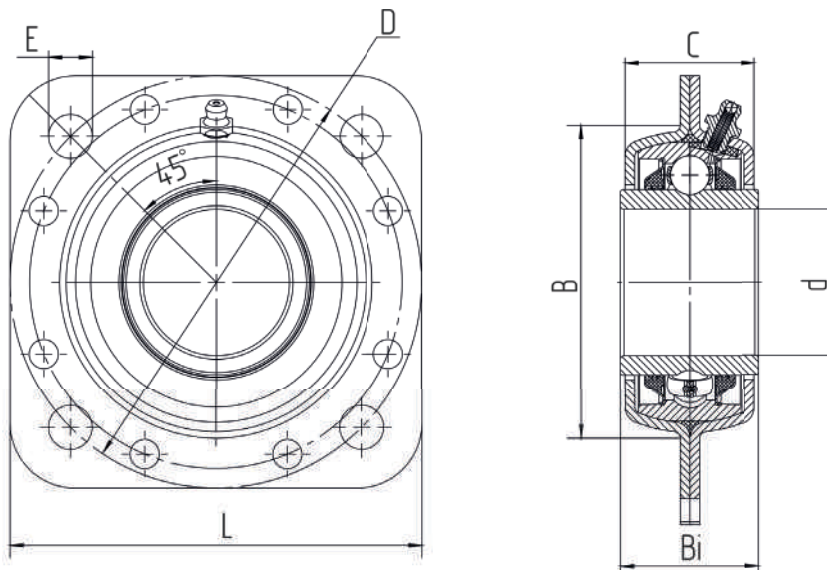

CROSS REFERENCE

Producer	OEM numbers
Timken FKL Peer	DHU 491 A GWST209PPB31 ST491A

Designation BBC-R	Application	Bore type	Description	A/d	Bi	L	D bolt circle	E
DHU 491A.LV	Seedbed finisher – Flanged disc	Round bore bearing	Tillage / Secondary tillage – Seedbed finisher	44,45	42,8	127	127	13,5
				F	G	B	C	
				-	-	98	42	

CROSS REFERENCE

Producer

Timken
FKL
Peer

OEM numbers

DHU 491 B
GWST 209 PPB38
ST491B

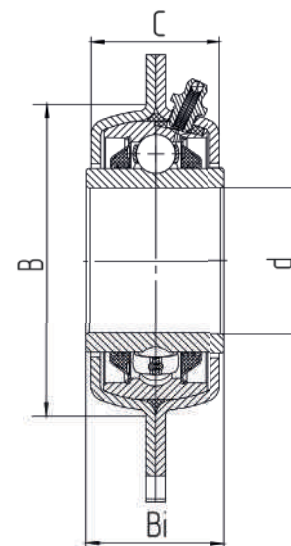
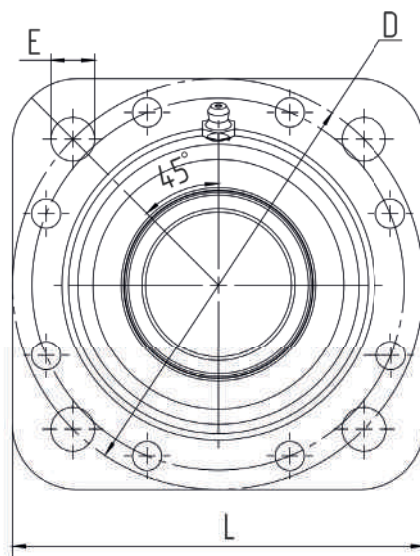

Designation BBC-R	Application	Bore type	Description	A/d	Bi	L	D bolt circle	E
DHU 491B.LV	Seedbed finisher – Flanged disc	Round bore bearing	Tillage / Secondary tillage – Seedbed finisher	38,1	42,8	127	127	13,5
				F	G	B	C	-

CROSS REFERENCE

Producer

Timken
Case

OEM numbers

FD 211-39 SQ2
KNT644400

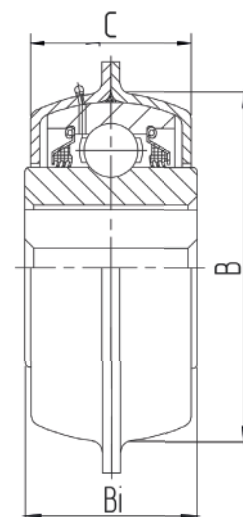
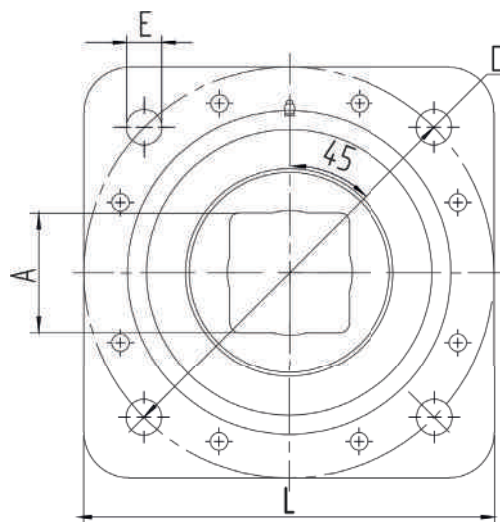

Designation BBC-R	Application	Bore type	Description	A/d	Bi	L	D bolt circle	E
FD 211SQ2.LV	Seedbed finisher – Flanged disc	Square bore bearing	Tillage / Secondary tillage – Seedbed finisher	39,5	55,5	139,7	139,7	13,5
				F	G	B	C	-

ST740B.LV

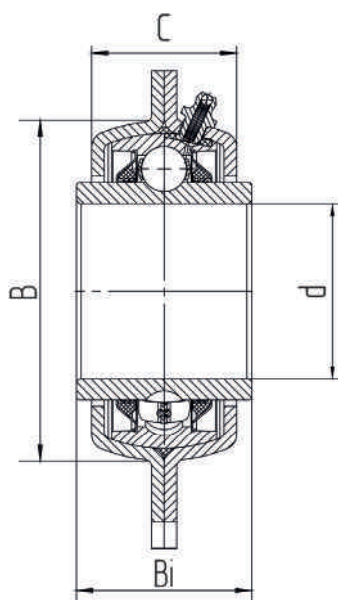
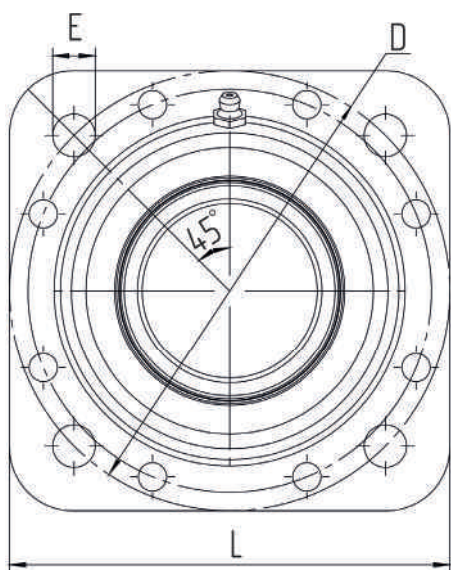

CROSS REFERENCE

Producer	OEM numbers
Timken	ST740B

Designation BBC-R	Application	Bore type	Description	A/d	Bi	L	D bolt circle	E
ST740B.LV	Seedbed finisher – Flanged disc	Square bore bearing	Tillage / Secondary tillage – Seedbed finisher	55,57	55,5	139,7	139,7	13,5
				F	G	B	C	
				-	-	114,9	46	

CE066.LV

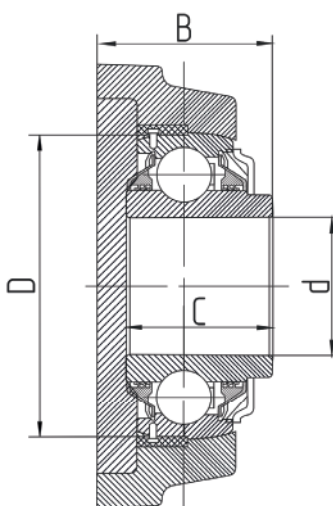
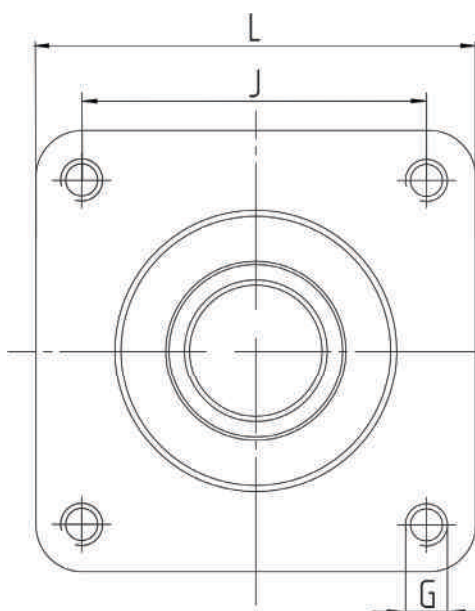

CROSS REFERENCE

Producer	OEM numbers
FKL	LSFR 308-TBT.H.T.Zn
Amazone	CE066
Amazone	CE078
Amazone	957305
Horsh	00240028
SNR-NTN	UCFE308
SNR-NTN	A01X1=UC308X1 +FE308A01
SNR-NTN	XUCFE308B01B
SNR-NTN	169 XUC308B168
Peer	UC 308 X1

Designation BBC-R	Application	Bore type	Description	d	D	L	J
CE066.LV	RollFlex Packer	Round bore bearing	Tillage / Secondary tillage – Seedbed finisher	40	90	130	101,5
				G	B	C	
				M12	51,4	42,9	

CROSS REFERENCE

Producer	OEM numbers
FKL	LSGR 205-FS
Lemken	3199371
Lemken	F239975
INA	RCJT 25x400x43 GGG
SNR	GGF 25 A07+UC 205 X1
RBF	PN00029
INA	F-239975-0200
INA	RCJT 25x400x43 GGG

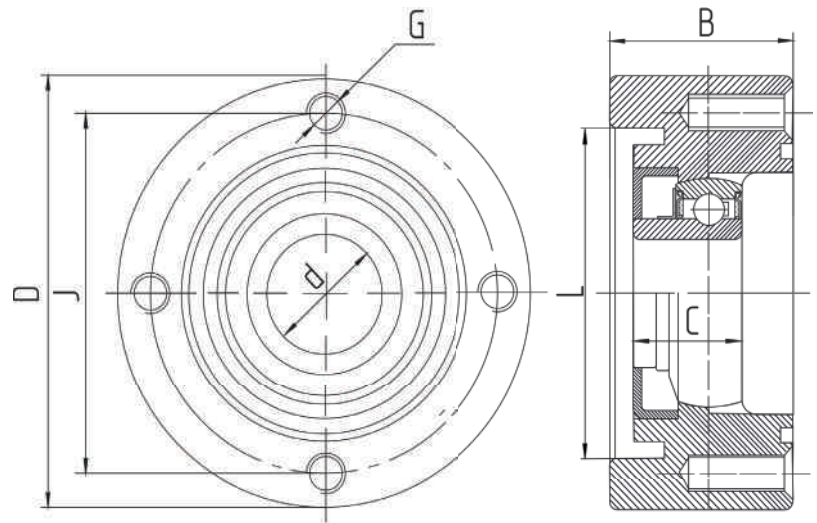

Designation BBC-R	Application	Bore type	Description	d	D	L	J
3199371.LV	Crumbler frame	Round bore bearing	Tillage / Secondary tillage – Seedbed finisher	25	99	76	82
				G	B	C	
				M10	43	25	

CROSS REFERENCE

Producer	OEM numbers
FKL	LSGR 207-TBS
INA	F-232812-0200
INA	RCJ 35x118x39.9
INA	RCJ 35 35x11835x39.9 4xM12
Lemken	3199372
RBF	PN00032RCJ

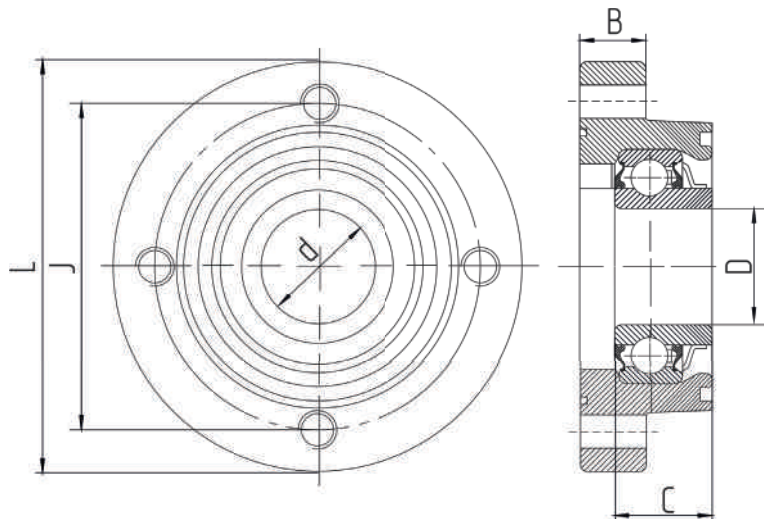

Designation BBC-R	Application	Bore type	Description	d	D	L	J
3199372.LV	Rubber ring roller	Round bore bearing	Tillage / Secondary tillage – Seedbed finisher	35	72	125	100
				G	B	C	
				M12	20	28,3	

3199367.LV

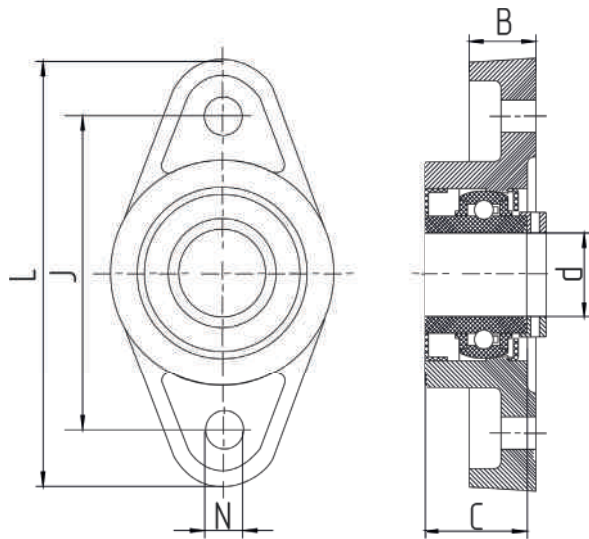

CROSS REFERENCE

Producer	OEM numbers
FKL	LSNR 205-2T
INA	RCJT 25x134x44.5
	GGG
INA	F233449
INA	RCJT 25CC AH02
Lemken	3199367
RBF	PN00028

Designation BBC-R	Application	Bore type	Description	d	L	J	B	C	N
3199367.LV	Tooth bar crumbler	Round bore bearing	Tillage / Secondary tillage – Seedbed finisher	25	135	99	21	35	11

3199352.LV

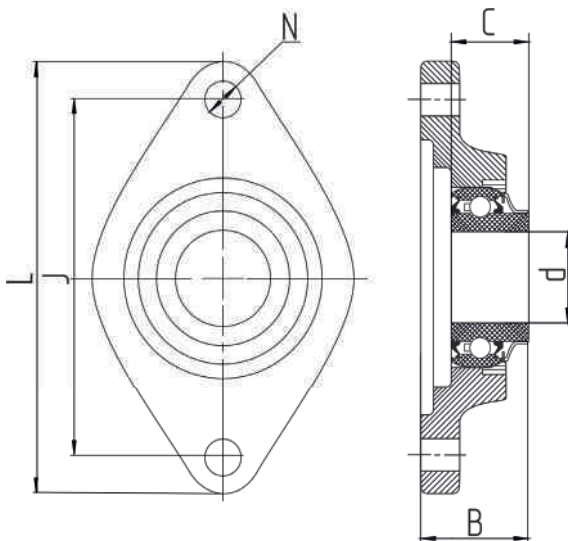

CROSS REFERENCE

Producer	OEM numbers
FKL	LSNR 207-TBS
INA	F-232812.03.RCJT
Lemken	3199352
RBF	PN00030

Designation BBC-R	Application	Bore type	Description	d	L	J	B	C	N
3199352.LV	Seedbed finisher – Flanged unit assembly	Round bore bearing	Tillage / Secondary tillage – Seedbed finisher	35	155	130	40	28,3	14

CROSS REFERENCE

Producer	OEM numbers
FKL	LSQFG 210-2PB.H
INA	TCF50-2C-AH01-GGG
Peer	W210-50MM-MF-R-DF-A362
Peer	BB210-50MM-MF-R-DF-A362
Horch	00240177
Horch	00240159
Horch	00240153

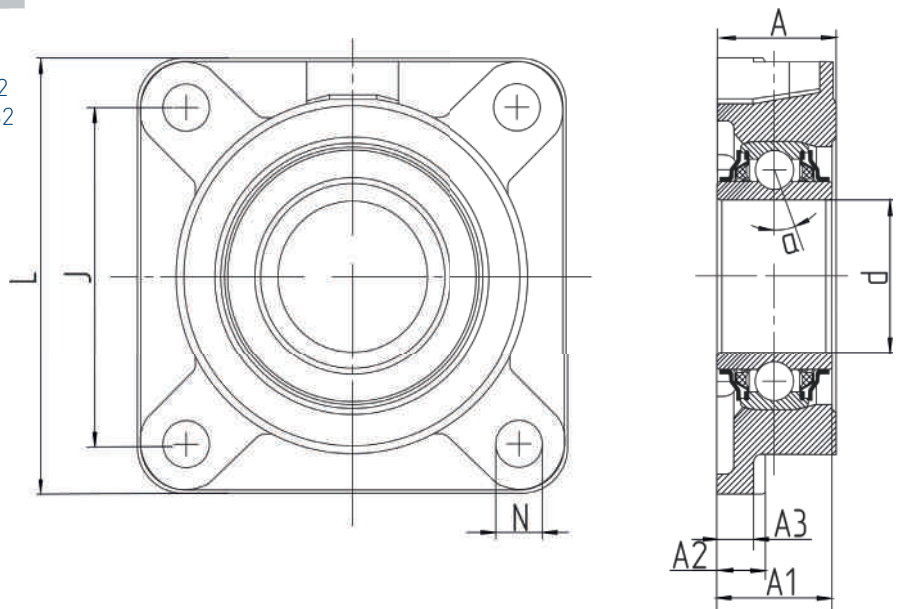

Designation BBC-R	Application	Bore type	Description	d	A1	A2	A3	J
0020177.LV	Seedbed finisher – Flanged unit assembly	Round bore bearing	Tillage / Secondary tillage – Seedbed finisher	50	38,5	16	12	111
				L	A	N	a	
				143	40	17	25°	

CROSS REFERENCE

Producer	OEM numbers
Koyo	DAC 30620030
Lemken	3198760
RBF	PN60005

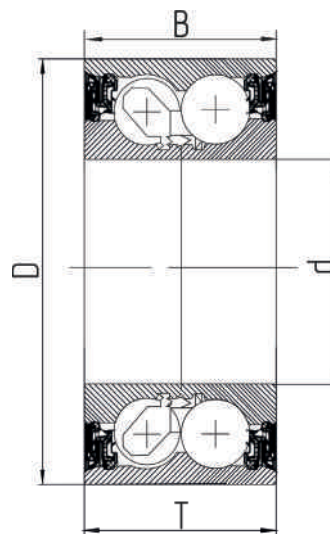

Designation BBC-R	Application	Bore type	Description	Seal type	d	D	T	B
306230.LV	Independent tillage disc – Hub bearing unit	Round bore bearing	Tillage Secondary tillage – Independent tillage disc	2-lip	30	62	30	30

357234.LV

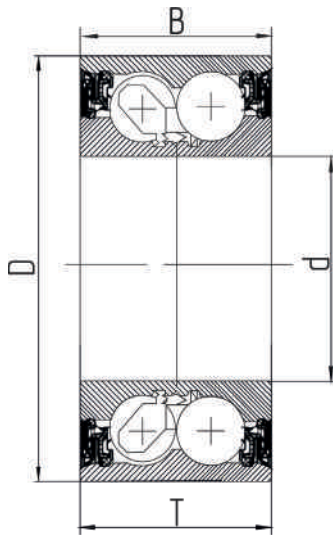

CROSS REFERENCE

Producer	OEM numbers
Koyo	DAC 35720034
SKF	VKBA 857D
FAG	540763
Lemken	F214101-13198750
Lemken	3198750
SNR	GB-40582
Claas	939717.0
Fersa	F16201
RBF	PN60002

Designation BBC-R	Application	Bore type	Description	Seal type	d	D	T	B
357234.LV	Independent tillage disc – Hub bearing unit	Round bore bearing	Tillage Secondary tillage – Independent tillage disc	2-lip	35	72	34	34

AA30942.LV

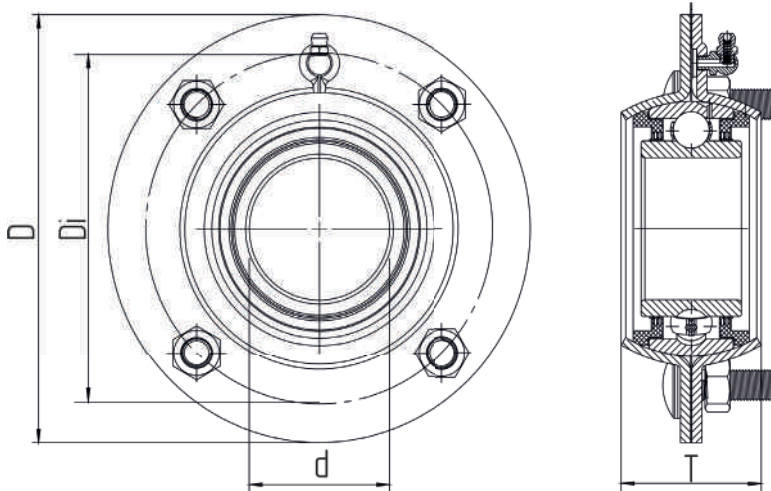

CROSS REFERENCE

Producer	OEM numbers
FKL	GWST211PPB20
John Deere Unit	AA30942
John Deere	AA29784
John Deere	A39169
NTN	ST 211-2 3/16
Timken just bearing	GW 211 PPB20

Designation BBC-R	Application	Bore type	Description	d	D	T	Di
AA30942.LV	Gang disc – Relubricatable bearing unit	Round bore bearing	Tillage / Secondary tillage – Seedbed finisher	55,7	168	55,5	138

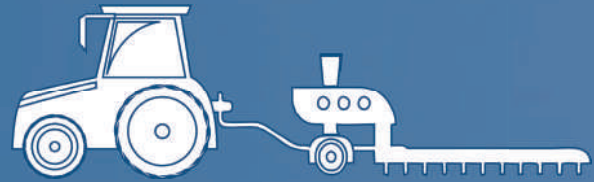

Seeding

The sowing process consists of several stages: furrow formation, seed planting, fertilization, seed closure and furrow rolling. These simple processes require high precision and productivity. Currently, the cost of fertilizer and seed is a key issue in the seed budget. The accuracy of sowing, the introduction of mineral fertilizers, the quality of packing (ramming) directly depends on the work of the working bodies of the seeding complex - the disc coulters, the packing wheels. The malfunctioning of the mechanisms of the sowing machines leads to a significant increase in the consumption of seed and fertilizers, which in turn significantly reduces the yield and increases the lost profit.

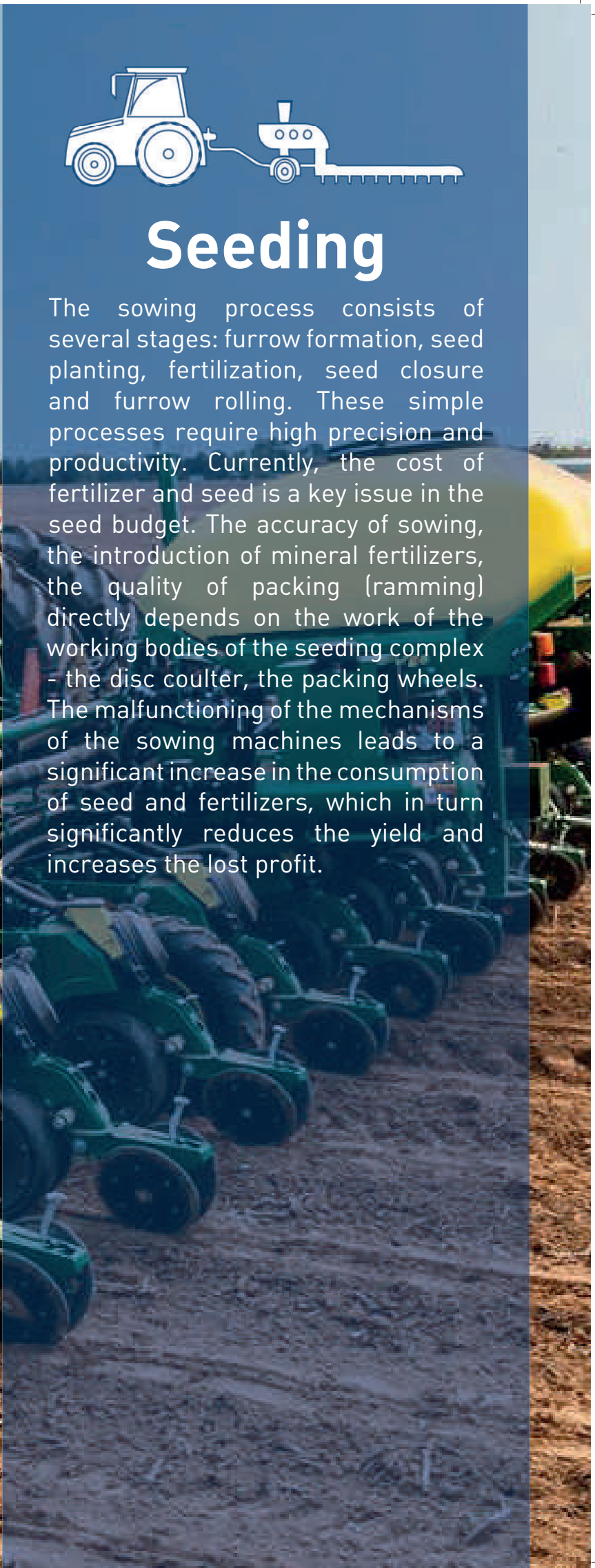

Elements of sowing machines in which bearings are used

- Colter opener discs
- Press-wheel coverers
- Gauge wheels
- Marker discs
- Elements of grain feeding mechanisms

Operating conditions

The sowing equipment is used extremely intensively for a short time, usually after a long period of inactivity in the open. The high intensity of the use of sowing equipment depends on the fact that the most acceptable conditions for seeding are limited to a short time interval. In addition to the high intensity of work, the operating conditions of the seeder mechanisms are in an environment of high humidity, acidity and the presence of solid contaminants. But even under these conditions, the working bodies - the colter opener discs, the press-wheel coverers - must ensure high accuracy of seed placement, high-quality seed placement and ramming. This can only be achieved through the use of special bearings in the units.

Solutions for sowing equipment actuators

One of the prerequisites for a good furrow and accurate seed placement is trouble-free operation of the colter opener discs. To ensure this, the bearings used on the opener hubs must be able to work under high axial loads and keep the lubricant inside the bearing clean. BBC-R has developed four contact points and triple seal bearings specifically for these conditions. The four-point contact in the bearing allows for significantly higher axial loads than a conventional deep groove ball bearing, while the reinforced triple lip seal protects against contamination entering the bearing. This design of the bearings allows for a long trouble-free operation of the sowing equipment. This achieves significant cost savings and increases overall productivity.

CROSS REFERENCE

Producer	OEM numbers
FKL	VP-16/40/74.5
Gaspardo	56345058
Gaspardo	F04100040
Kuhn	N00861A0
RBF	PN00035

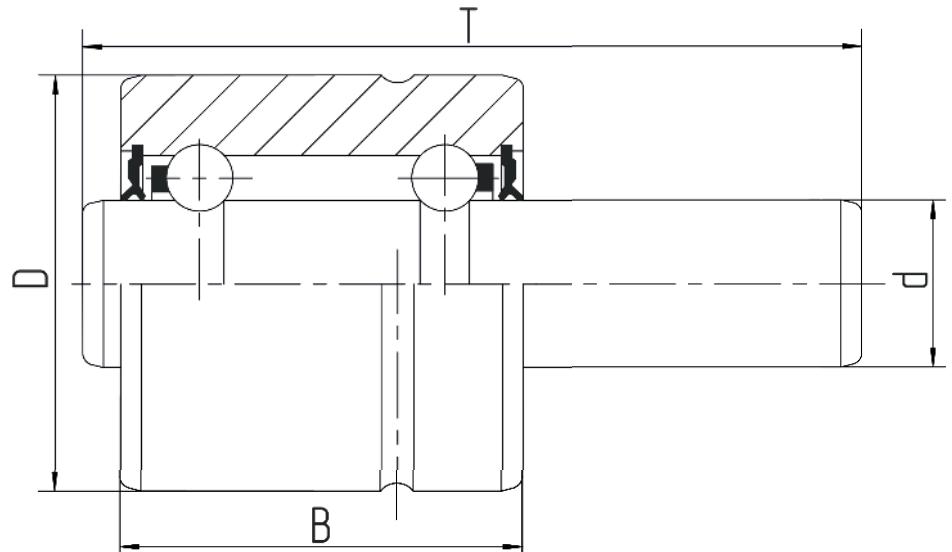

Designation BBC-R	Application	Bore type	Description	d	D	T	B
F04100040.LV	Gauge wheel – Special bearings	Shaft	Seeding / Gauge wheel	15,918	40	74,5	38,9

CROSS REFERENCE

Producer	OEM numbers
INA	WB01750
FKL	885154B
Peer	WP5203-KRP2-N-A217
Koyo	1806930S
Koyo	IB06930 SRS
Great Plains	822-023C
Great Plains	822-023C
Great Plains	851-SMA885154B
Horch	00310131
Horch	96140018
Massey Ferguson	446612M1
Massey Ferguson	7535011
John Deere	AN131668
John Deere	AA49161
John Deere	AA38106
RBF	PN00043

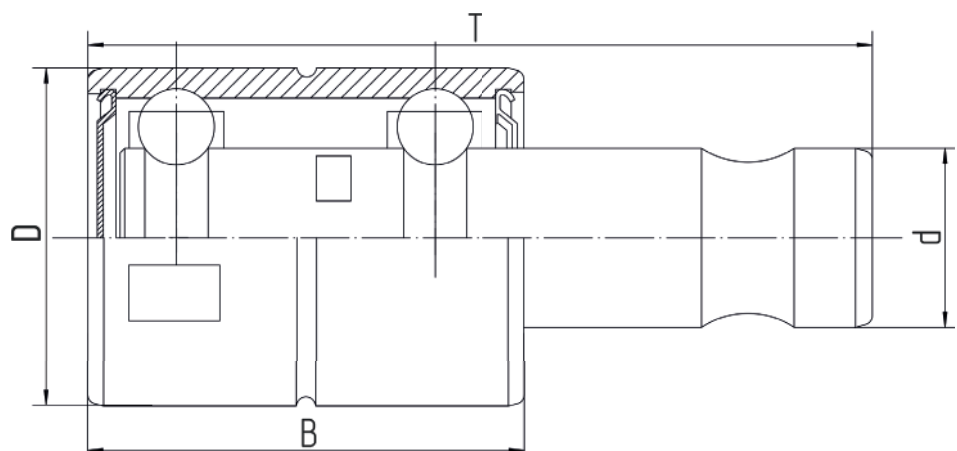

Designation BBC-R	Application	Bore type	Description	d	D	T	B
885154B.LV	Gauge wheel – Special bearings	Shaft	Seeding / Gauge wheel	15,918	30	69,4	38,9

AA35951B.LV

CROSS REFERENCE

Producer	OEM numbers
FKL	885152
John Deere	AA35951B
CNH	128558C91
CNH	ST 022-096
Gaspardo	F04100041R
John Deere	AA21015
John Deere	AA35741
Kinze	GA2022
Toro	751290
Toro	AC70593891

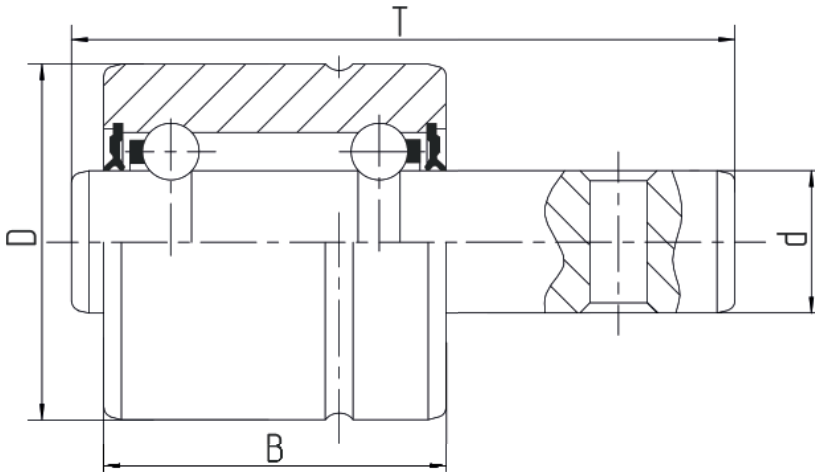

Designation BBC-R	Application	Bore type	Description	d	D	T	B
AA35951B.LV	Gauge wheel – Special bearings	Shaft	Seeding /Gauge wheel	15,918	30	69,4	38,9

F04100149.LV

CROSS REFERENCE

Producer	OEM numbers
FKL	SL2 5203-2T
Gaspardo	F04100149

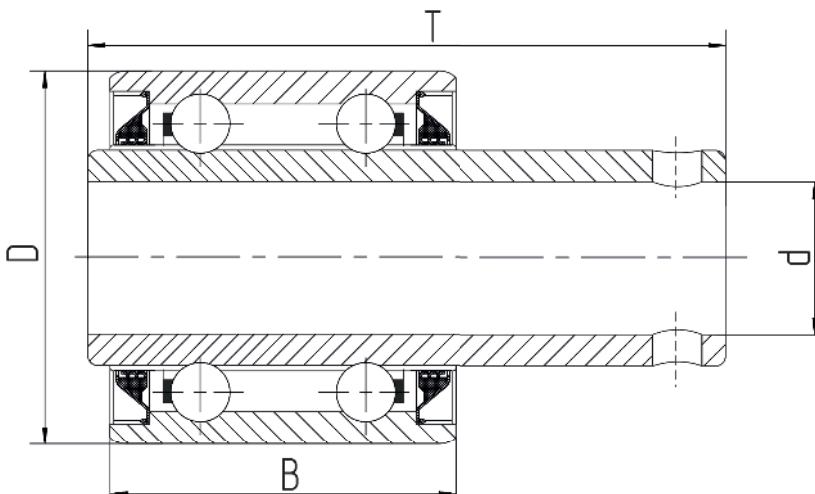

Designation BBC-R	Application	Bore type	Description	d	D	T	B
F04100149.LV	Gauge wheel – Special bearings	Shaft	Seeding / Gauge wheel	16,3	40	72	38,93

CROSS REFERENCE

Producer	OEM numbers
FKL Great Plains	SL53-014-2T 188-006V

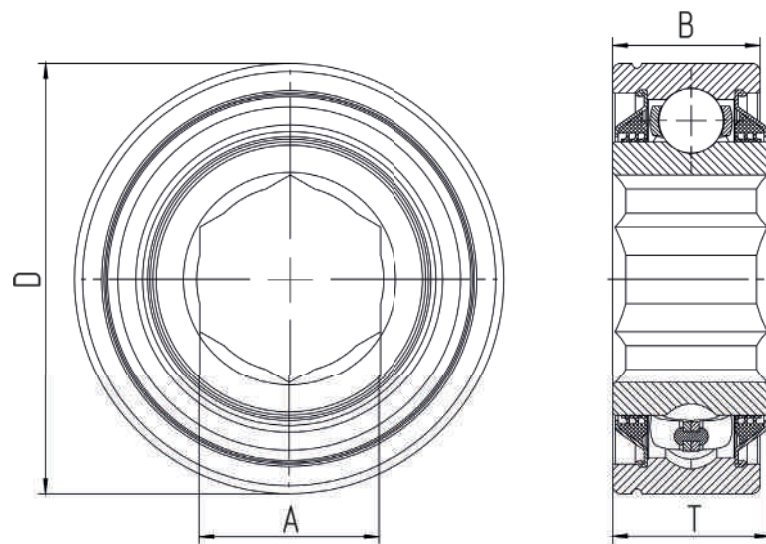

Designation BBC-R	Application	Bore type	Description	A	D	T	B
188-006.LV	Seedmeter drive shaft – Special bearings and units	Hexagonal bore bearing	Seeding / Seedmeter and seedmeter drive shaft	22,225	53,086	19,40	18,288

CROSS REFERENCE

Producer	OEM numbers
FKL Great Plains	SLE 53-012-2T 188-009V

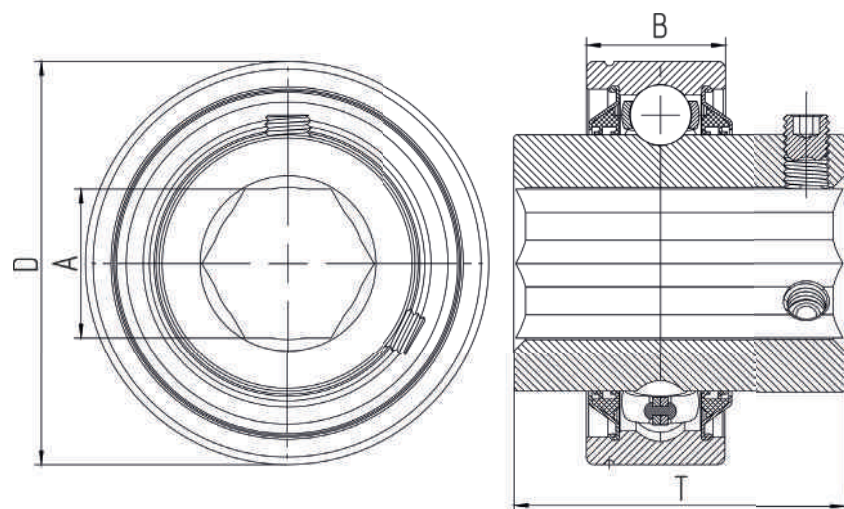

Designation BBC-R	Application	Bore type	Description	A	D	T	B
188-009.LV	Seedmeter drive shaft – Special bearings and units	Hexagonal bore bearing	Seeding / Seedmeter and seedmeter drive shaft	19,55	53,086	43,5	18,288

188-004.LV

CROSS REFERENCE

Producer

FKL
Great Plains

OEM numbers

SLU 53-012-2T
188-004V

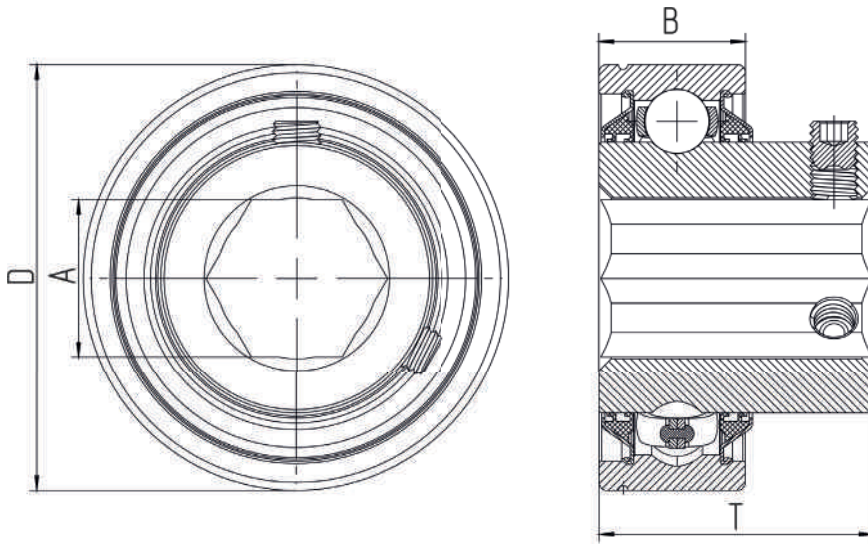

Designation BBC-R	Application	Bore type	Description	A	D	T	B
188-004.LV	Seedmeter drive shaft – Special bearings and units	Hexagonal bore bearing	Seeding / Seedmeter and seedmeter drive shaft	19,55	53,086	34,2	18,288

204KRRB2.LV

CROSS REFERENCE

Producer

Fafnir
Kverneland
BCA
Great Plains
Link Belt

OEM numbers

204KRRB2
AC676062 (HPS011GP
A-HPS011GP
11K204N

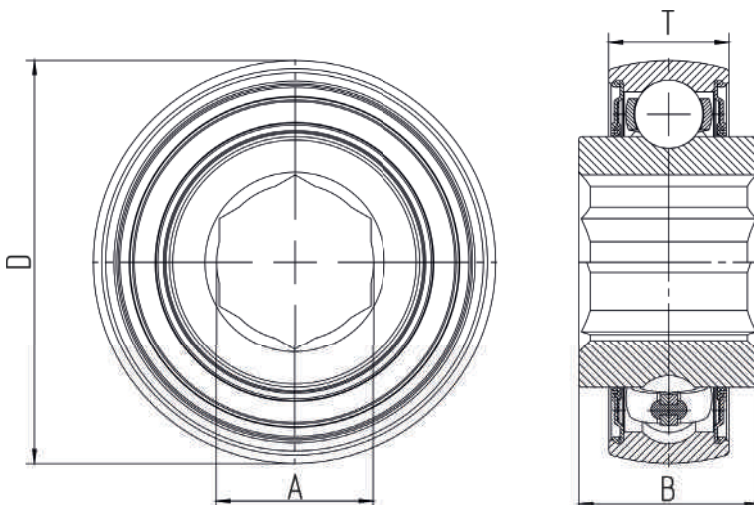

Designation BBC-R	Application	Bore type	Description	A	D	T	B
204KRRB2.LV	Seedmeter drive shaft – Special bearings and units	Hexagonal bore bearing	Seeding /Seedmeter and seedmeter drive shaft	17,65	47	21	14

205KRR2.LV

CROSS REFERENCE

Producer	OEM numbers
Fafnir	205KRR2
Timken	205 KRR2 C1
INA	205 KRR AH02
INA	SK014-205-KRR
Monosem	10161008
CNH	180302C91
CNH	189015C91
CNH	47928691
Massey Ferguson	842696M1
John Deere	AA28271
John Deere	AE29876
Kinze	GA5116

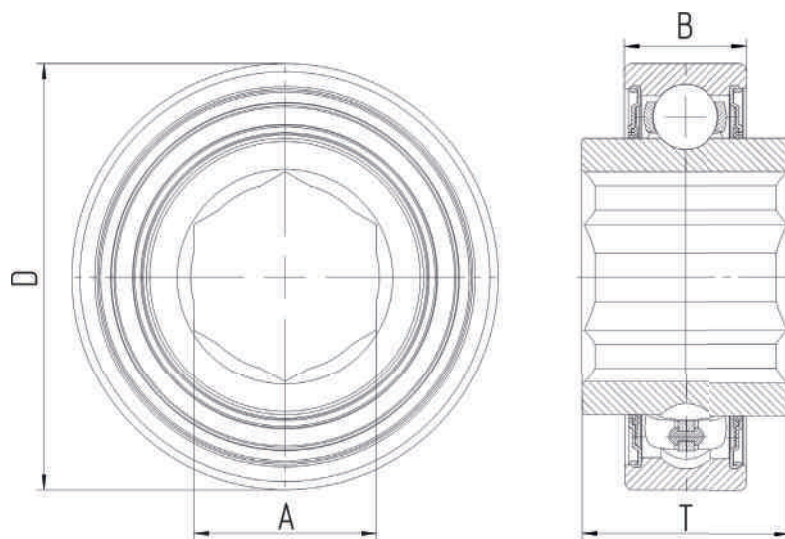

Designation BBC-R	Application	Bore type	Description	A	D	T	B
205KRR2.LV	Seedmeter drive shaft – Special bearings and units	Hexagonal bore bearing	Seeding /Seedmeter and seedmeter drive shaft	22.225	52	25.4	15

202KRR3.LV

CROSS REFERENCE

Producer	OEM numbers
Timken	202KRR3
John Deere	JD7172

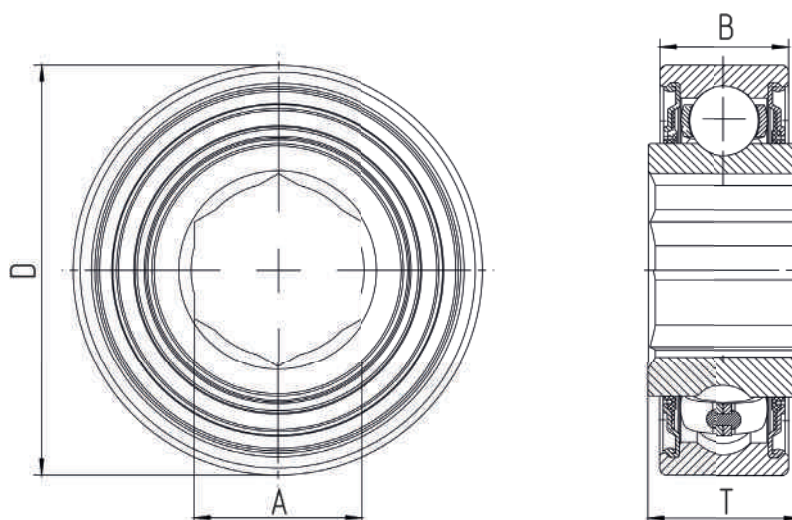

Designation BBC-R	Application	Bore type	Description	A	D	T	B
202KRR3.LV	Seedmeter drive shaft – Special bearings and units	Hexagonal bore bearing	Seeding /Seedmeter and seedmeter drive shaft	14,30	35	13	11

W247647B.LV

CROSS REFERENCE

Producer	OEM numbers
AGCO	W247647B

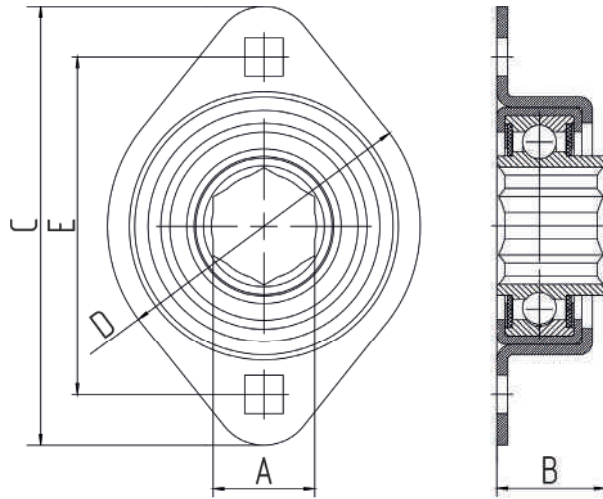

Designation BBC-R	Application	Bore type	Description	A	E	C	B	D
W247647B.LV	Seedmeter drive shaft – Special bearings and units	Hexagonal bore flange bearing	Seeding / Seedmeter and seedmeter drive shaft	19,075	63,5	82,5	20,4	58,7

F110390.LV

CROSS REFERENCE

Producer	OEM numbers
INA	F110390
FKL	3204 T
Semeato	888110390

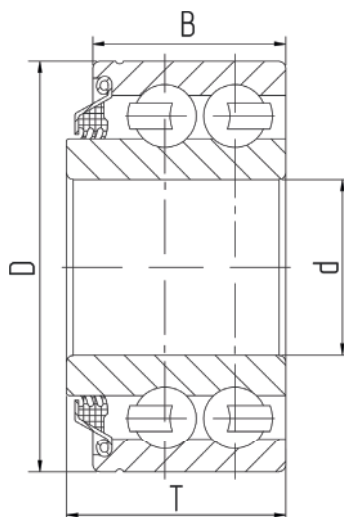

Designation BBC-R	Application	Bore type	Description	d	D	T	B
F110390.LV	Disc Opener – Double row angular contact ball bearing	Round bore bearing	Seeding / Disc opener	20	47	25,2	22

F562024KLQ02.KLQ.LV

CROSS REFERENCE

Producer	OEM numbers
FAG	F-562024.02.KLQ
INA	000308
RBF	PN0083
Horch	00240200

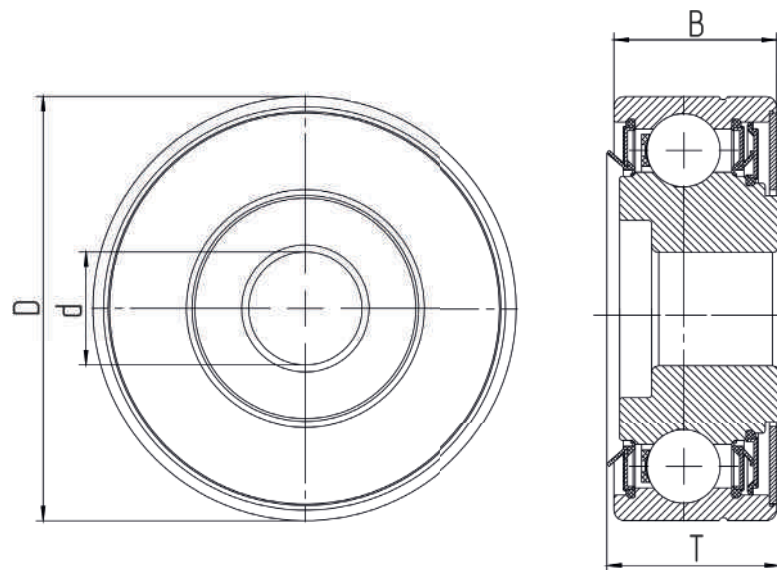

Designation BBC-R	Application	Bore type	Description	d	D	T	B
F562024KLQ02.KLQ.LV	Seeding bearing solutions	Round bore bearing	Seeding / Disc opener	16	80	23,3	22,9

Q 203AH02.LV

CROSS REFERENCE

Producer	OEM numbers
Timken	BB203RR2
INA	Q 203PP.AH02
John Deere	AA281357
John Deere	AH63076
John Deere	AH100425
John Deere	AN10097N
John Deere	AN141120
John Deere	AN142670
CNH	2149261C91
CNH	666624R91

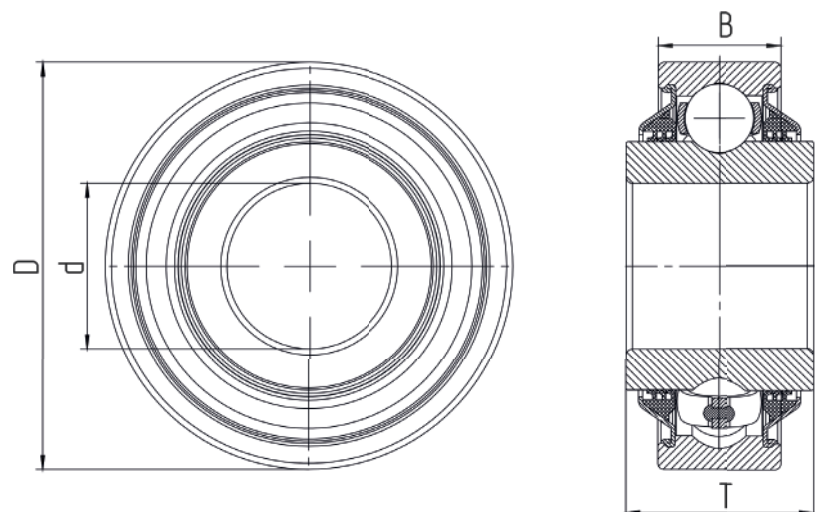

Designation BBC-R	Application	Bore type	Description	d	D	T	B
Q 203AH02.LV	Disc opener – Special bearings	Round bore bearing	Seeding / Disc opener	16,25	40	18,29	12

203JD.LV

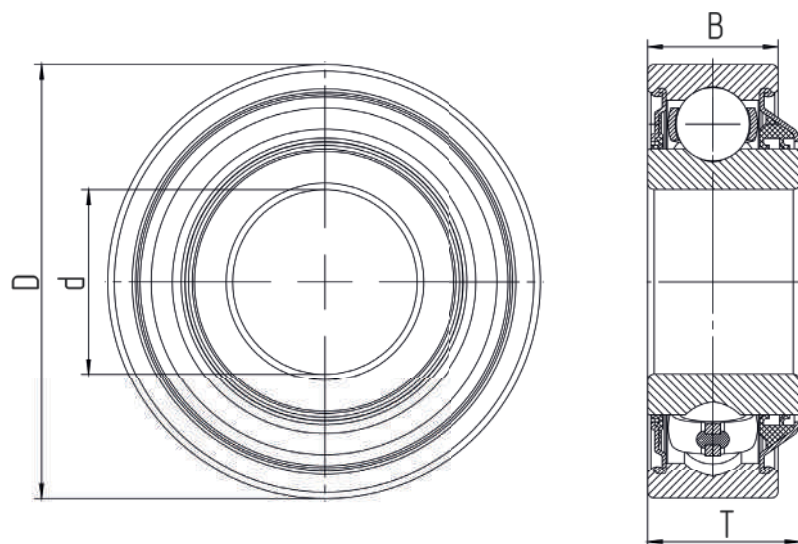

CROSS REFERENCE

Producer	OEM numbers
Peer	203JD
Fafnir	203 KYP2 + 6203 2RS + BUSH
Kabat	5203TN1
NTN	SX0366LULC3/L014
John Deere (unit)	P35638
Hyatt	87503A

Designation BBC-R	Application	Bore type	Description	d	D	T	B
203JD.LV	Disc opener – Special bearings KIT	Round bore bearing	Seeding /Disc opener	17	40	14	12

203KRR5.LV

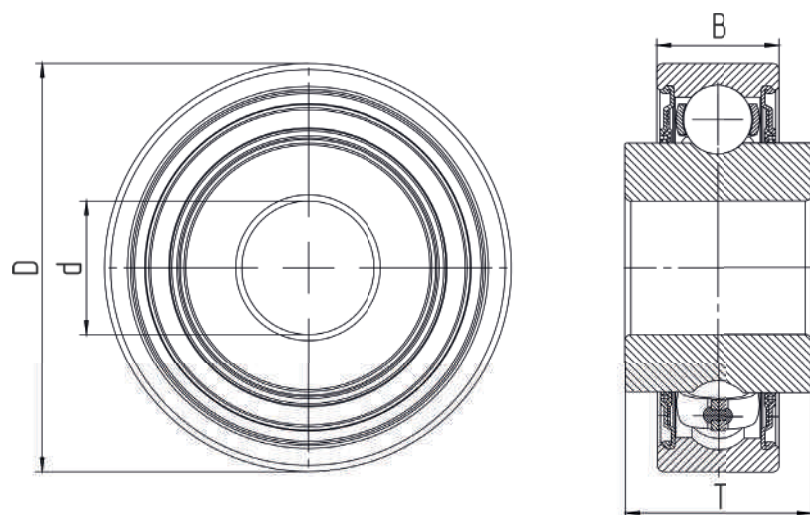

CROSS REFERENCE

Producer	OEM numbers
Timken	203KRR5
Timken	203 KRR5-R3
INA	203 KRR AH05
ALLIS CHALMERS	13209572
CNH	107095C91
CNH	608372R91
CNH	611928R91
CNH	613863R91
CNH	671067
Gehl	76156
Lemken	3198702
Lemken	3198563
Lemken	3198702
John Deere	JD9295
John Deere	T32178

Designation BBC-R	Application	Bore type	Description	d	D	T	B
203KRR5.LV	Disc opener – Special bearings	Round bore bearing	Seeding /Disc opener	13,08	40	18,288	12

CROSS REFERENCE

Producer	OEM numbers
Fafnir	204 PY3
INA	204 KRNP AH01
INA	F-556129.03.KLQ
BCA	204FVMN
Koyo	SX03A18LULC 3PX1/L014
NTN	DG1645ARS
Horch	00240199
Horch	00310104
CNH	492757R91
CNH	493532R91
CNH	1268017C91
CNH	492757R91
CNH	493532R91
KINZE	GA2014
John Deere	AA21480
Massey Ferguson	852270

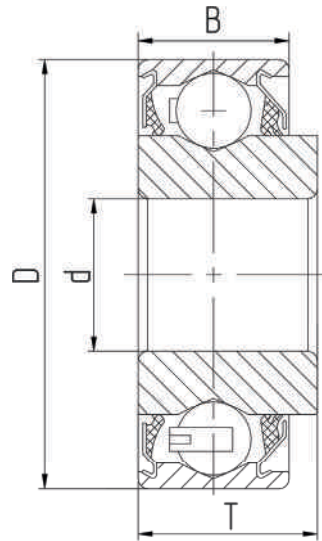

Designation BBC-R	Application	Bore type	Description	d	D	T	B
204PY3.LV	Disc opener – Special bearings	Round bore bearing	Seeding /Disc opener	16,027	45,225	18,67	15,4

CROSS REFERENCE

Producer	OEM numbers
Timken	204 RY2

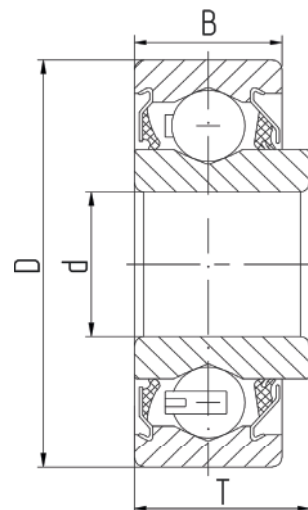

Designation BBC-R	Application	Bore type	Description	d	D	T	B
204RY2.LV	Disc opener – Special bearings	Round bore bearing	Seeding /Disc opener	16,027	45,225	18,67	15,4

204KRD4.LV

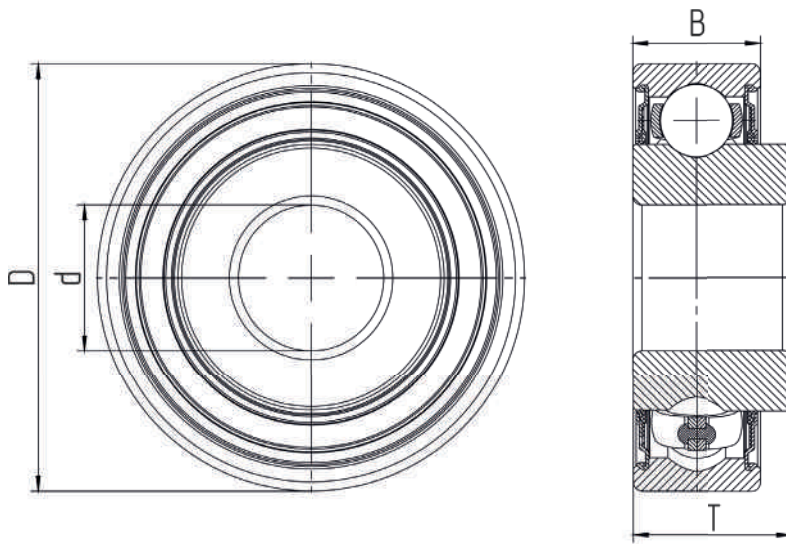

CROSS REFERENCE

Producer	OEM numbers
Peer	204KRD4
FGB	204FGB
MRC	204SFZ5
White	300279B
White	W247167B1
Clark	65108539
Newdep	87504U
John Deere	PM204FGBN
Massey Ferguson	PS01108

Designation BBC-R	Application	Bore type	Description	d	D	T	B
204KRD4.LV	Disc opener – Special bearings	Round bore bearing	Seeding /Disc opener	16,027	47	17,4	14

205KRP2.LV

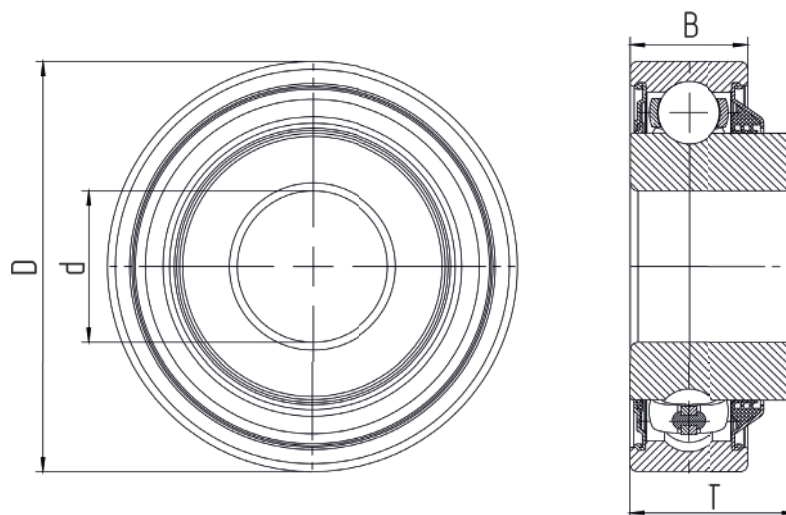

CROSS REFERENCE

Producer	OEM numbers
Peer	205KRP2
NTN	SBX 05A55 LMLSQ1
CNH	1337998C1
Crause	40-155
Marliss	702020
John Deere	A27002
Kuhn	Q4008330
Sun Flower	SNDR30005

Designation BBC-R	Application	Bore type	Description	d	D	T	B
205KRP2.LV	Disc opener – Special bearings	Round bore bearing	Seeding /Disc opener	19,075	52	21	15

CROSS REFERENCE

Producer	OEM numbers
Peer	206KRP4
BCA	206RTQ
KOYO	838425
John Deere	AA34616

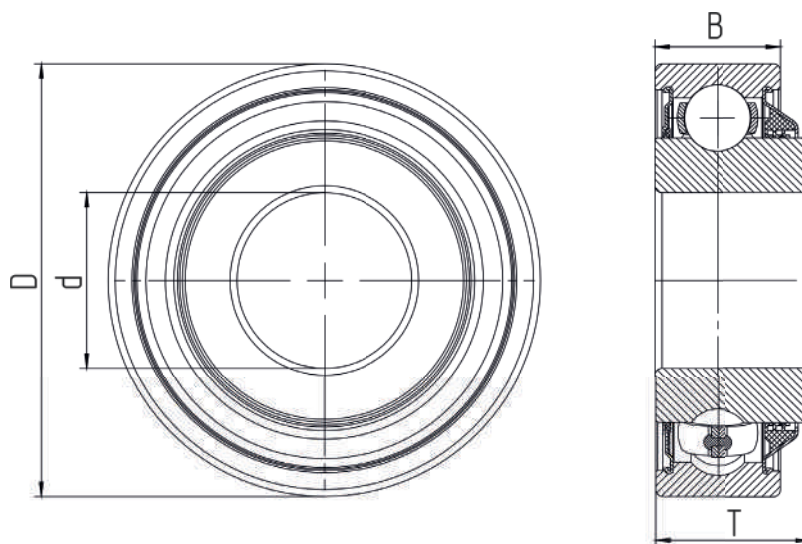

Designation BBC-R	Application	Bore type	Description	d	D	T	B
206KRP4.LV	Disc opener – Special bearings	Round bore bearing	Seeding /Disc opener	25	62	22,225	18

CROSS REFERENCE

Producer	OEM numbers
Timken	5203KYY2
Koyo	DAC164044 2RS
FKL	SL 5203 2T
Kinze	GA6171
Sun Flower	SN7218
Amazone	CA130
Gaspardo	F04100150
John Deere	AN212132
Kverneland	AC676096
Monosem	900125
Great Plains	822-170C
Kuhn	81101640
Amity	66261
CNH	47577193
CNH	306007A1
Horch	310926
Horch	240216

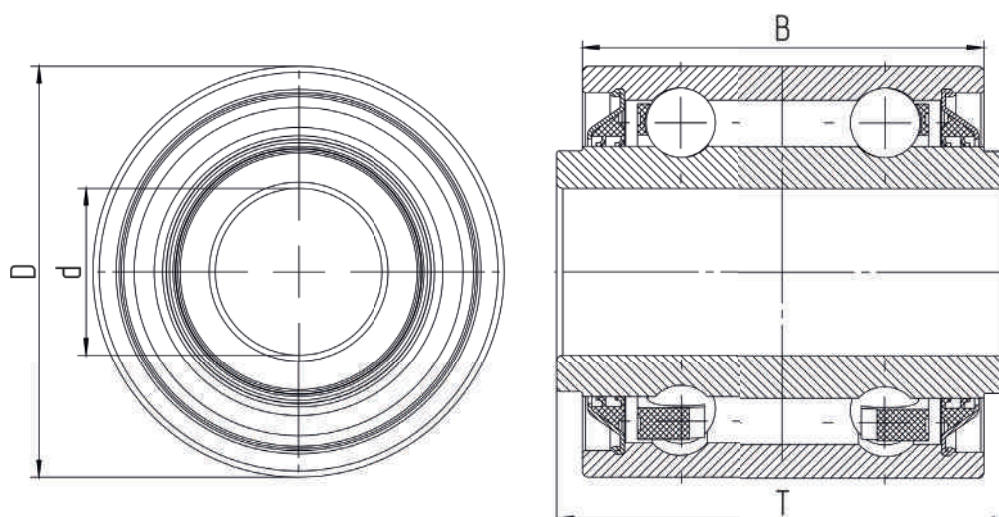

Designation BBC-R	Application	Bore type	Description	d	D	T	B
5203KYY2.LV	Disc opener – Special bearings	Round bore bearing	Seeding /Disc opener	16,256	40	44.12	39,12

5206KPP3.LV

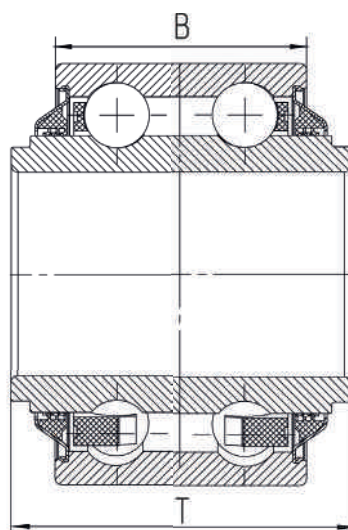
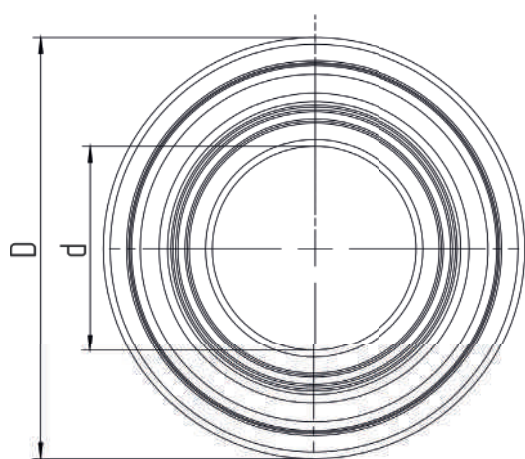

CROSS REFERENCE

Producer	OEM numbers
Peer	5206KPP3
Koyo	DRDAC306250-2RST
Great Plains	822-215C
CNH	87283953
John Deere	AN261054
John Deere	AN261766
John Deere	AN261637
Kinze	GA8603
Kinze	GA8641

Designation BBC-R	Application	Bore type	Description	d	D	T	B
5206KPP3.LV	Disc opener – Special bearings	Round bore bearing	Seeding /Disc opener	30,150	62	50	37

AA205DD.LV

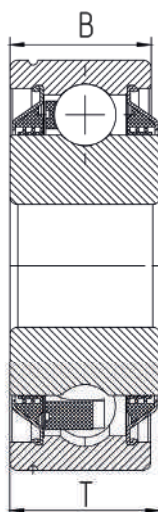
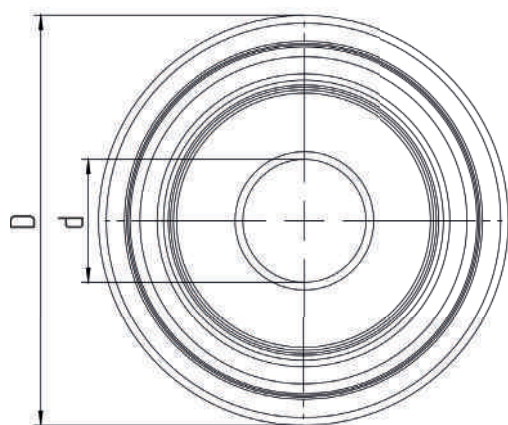

CROSS REFERENCE

Producer	OEM numbers
Peer	AA 205 DD
FKL	SL5316-2T
Great Plains	188-001V
Krause	40-172
BCA	205VWH
China	205GP
Fafnir	205DDS-5/8

Designation BBC-R	Application	Bore type	Description	d	D	T	B
AA205DD.LV	Disc opener – Special bearings	Round bore bearing	Seeding /Disc opener	16,13	53,086	19,43	18,263

CROSS REFERENCE

Producer	OEM numbers
INA	203 KRR AH02
NTN	SX0361LLCS41PX1/3AQ2
Fafnir	BB203KRR2
Peer	BB203KRR2FD
FKL	203KRR.AH02
BCA	203RRAR10
John Deere	AN281357
John Deere	AN100425
John Deere	AN142670
John Deere	AH63076
John Deere	AN141120
John Deere	JD9214
Massey Ferguson	832651M1
CNH	F16246
CNH	66553
CNH	2149261C91
CNH	666624R91
Gehl	520117
Grimme	B96.00410
Great Plains	822-095C

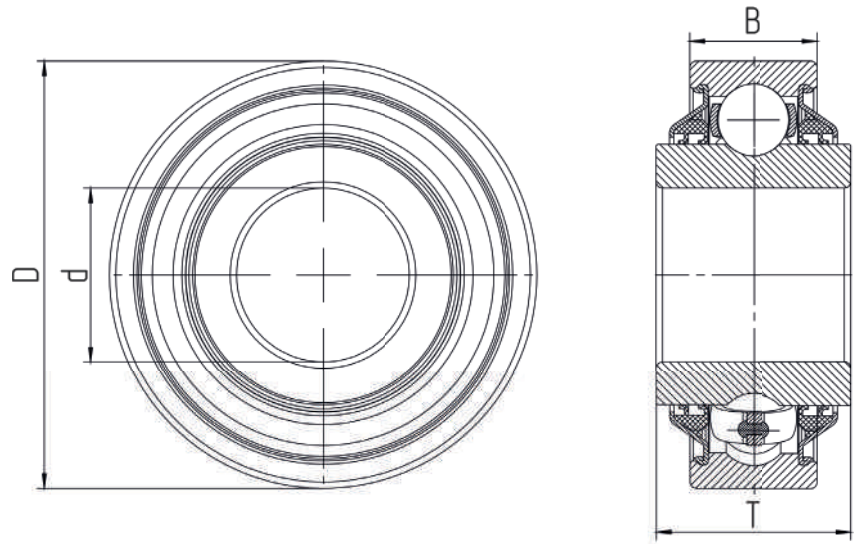

Designation BBC-R	Application	Bore type	Description	d	D	T	B
BB203KRR2FD.LV	Disc opener – Special bearings	Round bore bearing	Seeding /Disc opener	16,256	40	18,288	12

CROSS REFERENCE

Producer	OEM numbers
Timken	203 KYP2

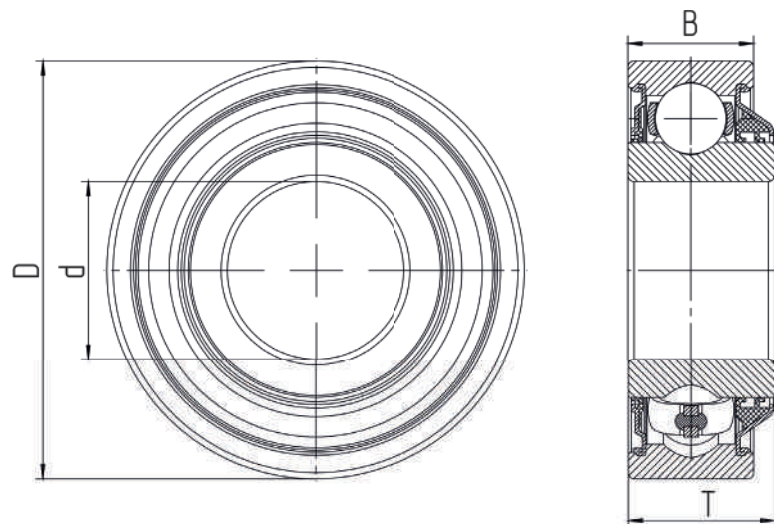

Designation BBC-R	Application	Bore type	Description	d	D	T	B
203KYP2.LV	Press wheel / Closing wheel – Special bearings	Round bore bearing	Seeding /Gauge wheel	17	40	14	12

204KRR.LV

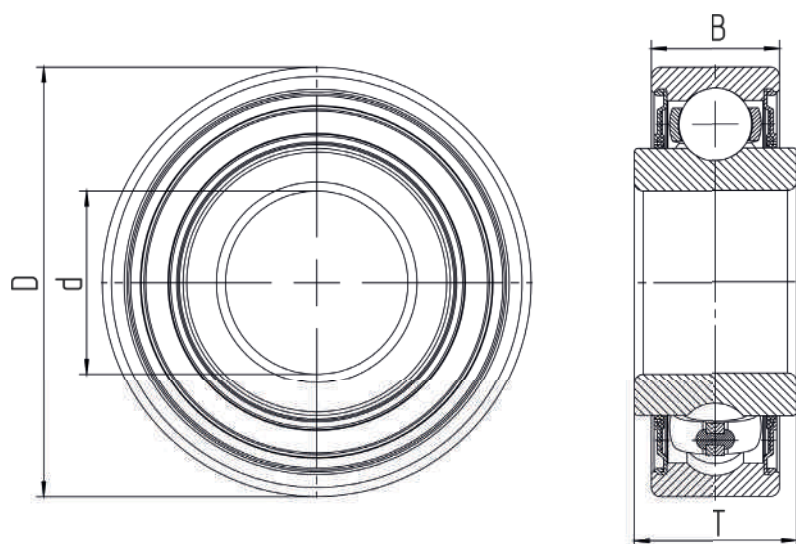

CROSS REFERENCE

Producer	OEM numbers
Timken	204KRR
Timken	204 KLL2
FAG	88504
CNH	02446N
CNH	06575AB
CNH	1341342C1
CNH	661001R91
Massey Ferguson	1005590M1
Massey Ferguson	832612IV11
Kverneland	AC671872
John Deere	JD7143

Designation BBC-R	Application	Bore type	Description	d	D	T	B
204KRR.LV	Press wheel / Closing wheel – Special bearings	Round bore bearing	Seeding /Gauge wheel	20	47	17,7	14

AA22558.LV

CROSS REFERENCE

Producer	OEM numbers
John Deere	AA22558

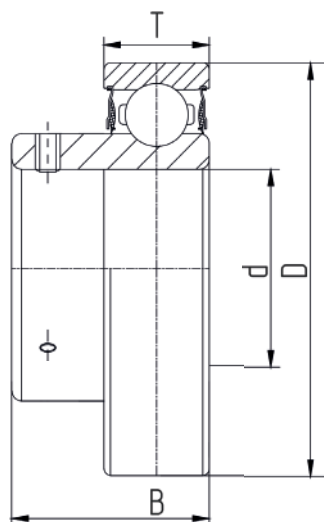

Designation BBC-R	Application	Bore type	Description	d	D	T	B
AA22558.LV	Press wheel / Closing wheel – Special bearings	Round bore bearing	Seeding /Gauge wheel	22,23	52	27	15

205KP6.LV

CROSS REFERENCE

Producer	OEM numbers
Fafnir	205KP6
Kelly	03A51-008
Lilliston	20-50-125
USA number	205TNJ

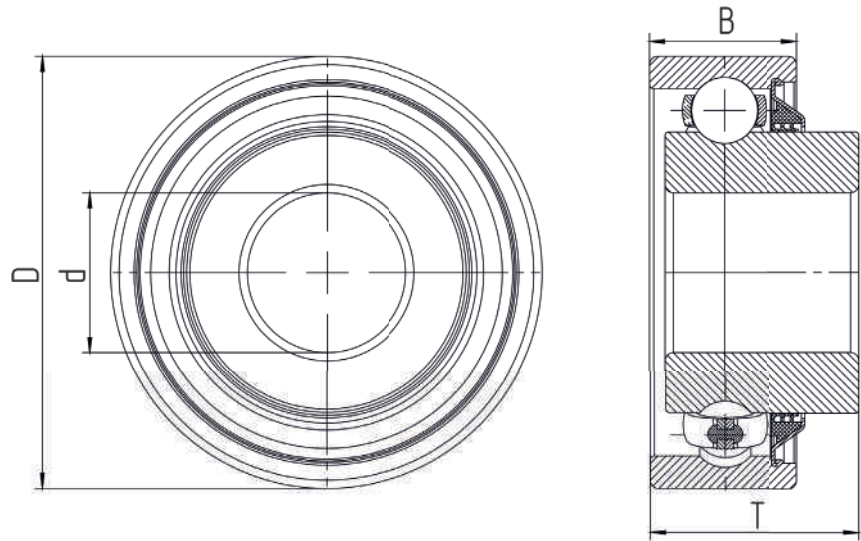

Designation BBC-R	Application	Bore type	Description	d	D	T	B
205KP6.LV	Disc opener – Special bearings	Round bore bearing	Seeding /Disc opener	19,05	52	25,5	17,78

205KR3.LV

CROSS REFERENCE

Producer	OEM numbers
Timken	205KR3
Lilliston	20-50-012
BCA	205RHN
CNH	669807C91
John Deere	JD1044
John Deere	JD10448
John Deere	JD9331
Peer	205RY3

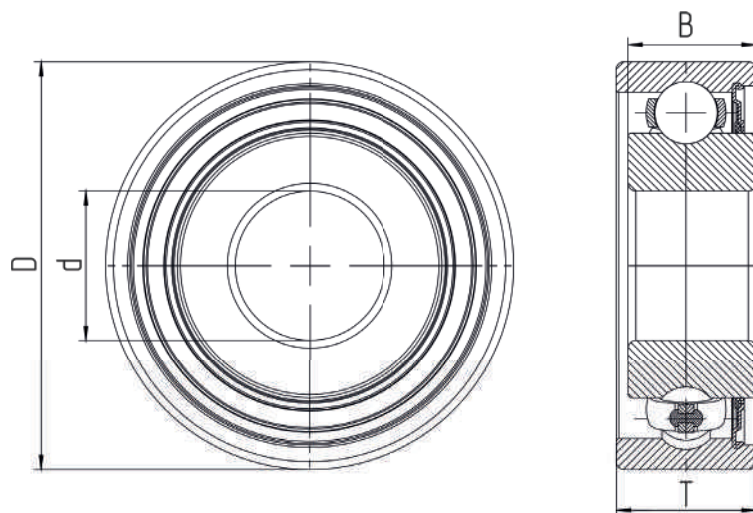

Designation BBC-R	Application	Bore type	Description	d	D	T	B
205KR3.LV	Disc opener – Special bearings	Round bore bearing	Seeding /Disc opener	19,05	52	17,78	16,25

BB203KRR5.LV

CROSS REFERENCE

Producer

FKL
Timken
Lemken

OEM numbers

O 203PP.AH05
BB203KRR5
3199369

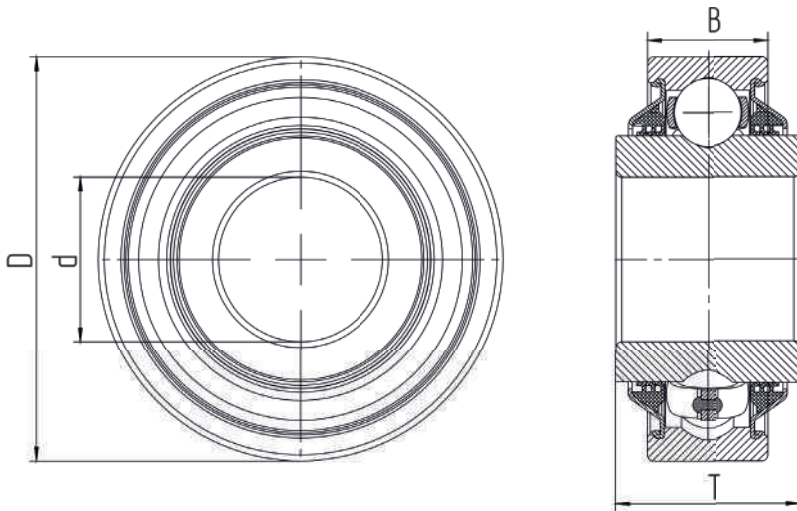

Designation BBC-R	Application	Bore type	Description	d	D	T	B
BB203KRR5.LV	Press wheel / Closing wheel – Special bearings	Round bore bearing	Seeding /Gauge wheel	13	40	18,29	12

G14830390.LV

CROSS REFERENCE

Producer

Gaspardo
FKL
RBF

OEM numbers

G14830390
SLE47-16S-2RS
PN00039

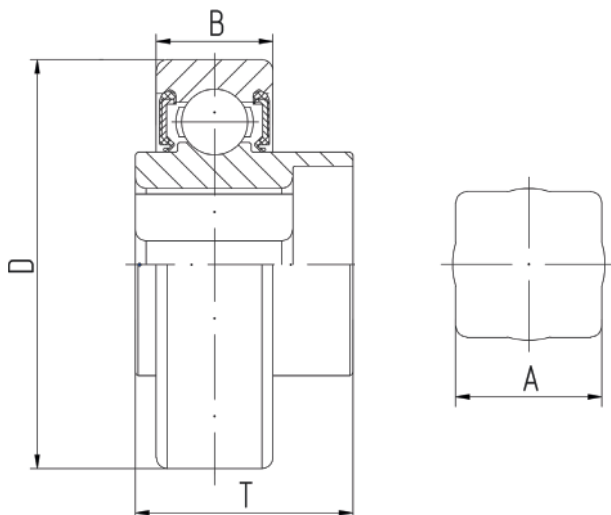

Designation BBC-R	Application	Bore type	Description	A	D	T	B
G14830390.LV	Seedmeter drive shaft – Special bearings and units	Square bore bearing	Seeding/Seedmeter and seedmeter drive shaft	16,35	47	25	12



Baling and Harvesting

Harvest

Harvesting is the culmination of an entire labour-intensive farming season. The technique used for harvesting is one of the most complex among all agricultural machines, combining many complex mechanisms working in difficult operating conditions.

Baling

The process of converting windrows of crop into bales, necessitates the pickup of crop, compacting and wrapping inside the bale chamber and ejection of the completed bale. Much of this processing relies on rollers and for a square baler, a reciprocating plunger, so multiple bearings are required to produce an effective as well as a precise baling process.



Operating conditions of grain harvesting equipment

After winter downtime, often outdoors, the combines are actively operated. A three-shift work schedule for several months of harvesting, with short service intervals are typical operating conditions of combines. The load on the machinery is also increased by the high abrasiveness of the environment, vibration loads and significant axial misalignments. between bearing supports on the housing elements of the combine. Repair of harvesting implements requires high qualifications of service personnel in an equipped workshop. To replace the bearing assemblies of harvesting implements, detailed disassembly of the mechanisms is often required. This process takes a significant amount of time and effort, and as you know, equipment downtime during the harvesting period, especially affects the final profit indicators.

Green forage harvesting

One of the most common types of animal feed preparation is the collection and formation of bales or swaths from the green mass of plants. Balers are used to perform this function. The process of swath formation consists of the selection of green mass, formation and binding of the swath inside the baler chamber with its subsequent unloading. For the formation and binding of the roll, numerous rollers are installed inside the baler, the rotation of which is provided by bearing supports.

Solutions for baler applications.

BBC-R offers a wide range of high performance bearings to keep your balers running smoothly over long periods of time.





Operating conditions

The process of forming a bale or swath inside the baler results in a high concentration of dust or moisture affecting the machine mechanisms. To ensure high productivity, accuracy of roll formation, and reliability of tying, high-quality operation of all machine mechanisms is required. One of the important elements involved in the formation and binding of the roll are the rollers on the bearing support. In order to avoid premature failure of mechanisms, bearing assemblies must have a high degree of protection against dust, dirt, moisture and small stones.

Solution for harvesting implements

BBC-R offers a wide range of bearings and bearing units, both serviceable and non-serviceable. A high degree of protection of bearings from contamination, no need for additional lubrication, allow to increase the life of bearings and, as a result, reduce the cost of equipment repairing and its downtime.

206KRR6.LV

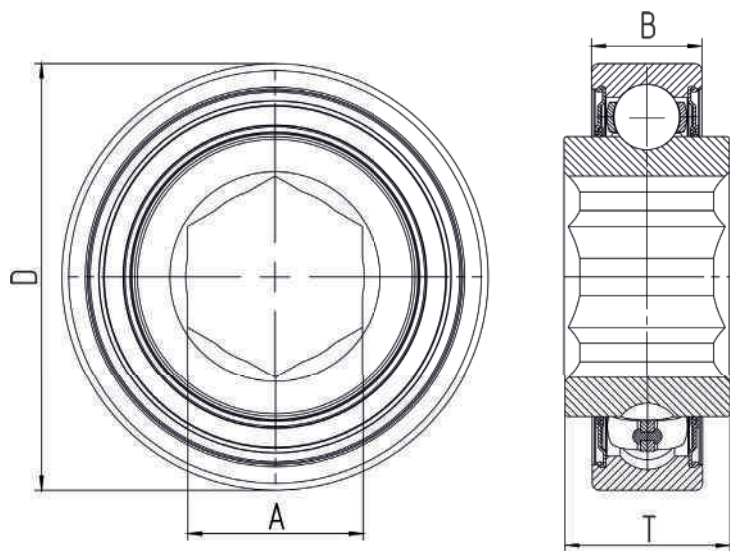

CROSS REFERENCE

Producer	OEM numbers
Timken	206KRR6
INA	206KRR AH06
CNH	135423
Massey Ferguson	842697M1
John Deere	JD9338

Designation BBC-R	Application	Bore type	Description	A	D	T	B
206KRR6.LV	Clean Grain / Residue – Insert and special bearings	Hexagonal bore bearing	Harvesting / Combine harvester – Clean	25,4	62	24	16

206KRRB6.LV

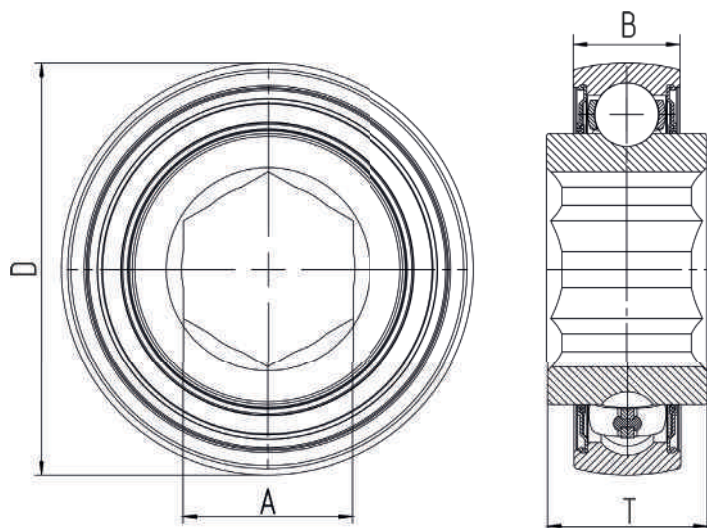

CROSS REFERENCE

Producer	OEM numbers
Timken	206KRRB6
INA	206 KRRB AH06
INA	SK100-206-KRR-B-AH11
Super Walter	11.102
CNH	135241
CNH	211587C91
CNH	57483C91
John Deere	AN100348
John Deere	JD9313

Designation BBC-R	Application	Bore type	Description	A	D	T	B
206KRRB6.LV	Clean Grain / Residue – Insert and special bearings	Hexagonal bore bearing	Harvesting/Combine harvester–Clean Grain/Residue	25,4	62	24	16

W208KRRB6.LV

CROSS REFERENCE

Producer	OEM numbers
Timken	W208KRRB6
BCA	HPS106GPN
John Deere	AE37204
CNH	694444

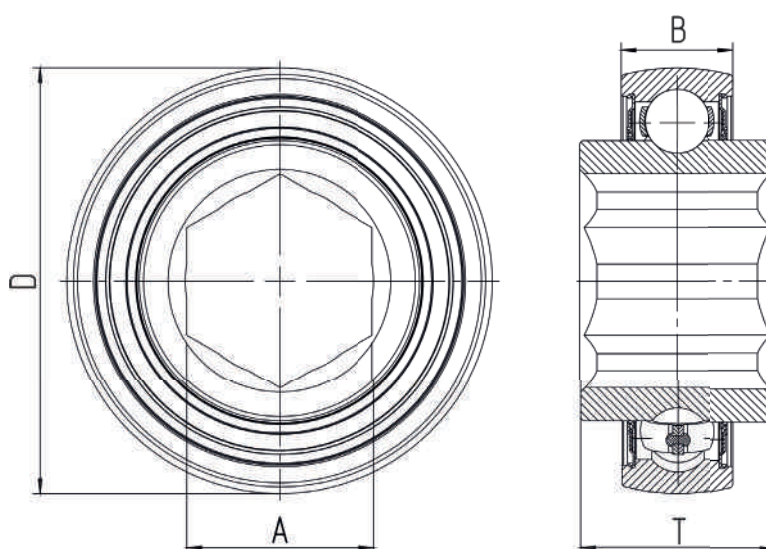

Designation BBC-R	Application	Bore type	Description	A	D	T	B
W208KRRB6.LV	Round baler – Insert and special bearings	Hexagonal bore bearing	Harvesting / Baling – Round baler	34,925	80	36,520	21

W208PPB16.LV

CROSS REFERENCE

Producer	OEM numbers
Timken	W208PPB16
BCA	HPC104TPA
NTN	2AH08-1.1/4V4
Massey Ferguson	1577800M1
Massey Ferguson	1577800W1
Massey Ferguson	31-1577800
Allis Chalmers	575883
CNH	700703101
CNH	70575883
CNH	70586143
CNH	86523785
John Deere	JD9373
John Deere	AE46606
John Deere	H114873

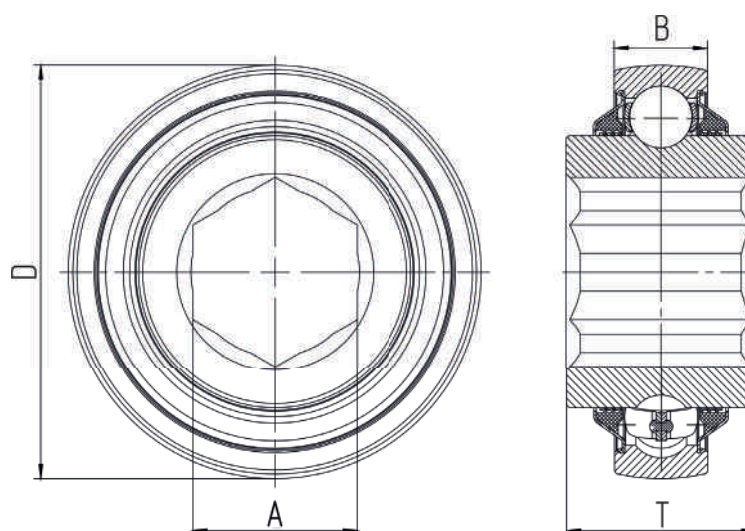

Designation BBC-R	Application	Bore type	Description	A	D	T	B
W208PPB16.LV	Feederhouse / Rotor – Insert and special bearings	Hexagonal bore bearing	Harvesting / Combine harvester– Feederhouse/Rotor	31,78	80	36,53	18

209KRRB2.LV

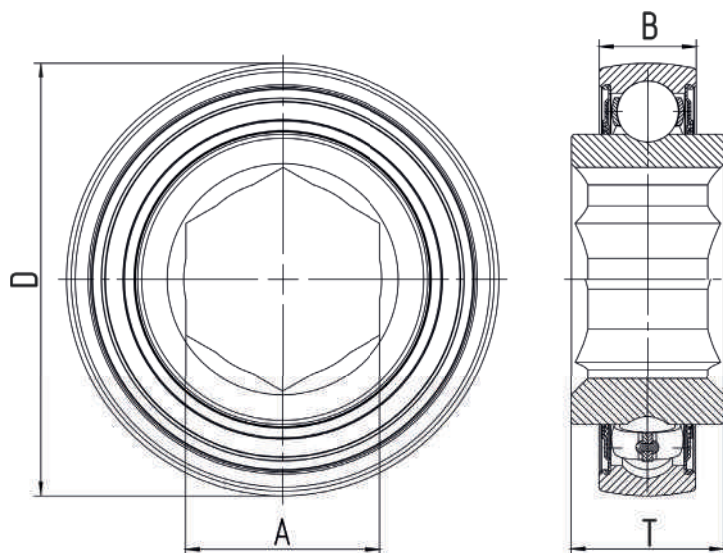

CROSS REFERENCE

Producer	OEM numbers
Timken	209KRRB2
Timken	209 KRRB2C2
Peer	2AH09 1 1/2
NTN	SBX0977C3/ L014Q1
BCA	HPS108GPHN
Mainero	68920009C
Mainero	68920-009
CNH	47577178
CNH	80286909
CNH	84330027
CNH	87660207
CNH	179665C91
John Deere	AE40895

Designation BBC-R	Application	Bore type	Description	A	D	T	B
209KRRB2.LV	Feederhouse / Rotor – Insert and special bearings	Hexagonal bore bearing	Harvesting/ Combine harvester – Feederhouse/Rotor	38,1	85	30	19

204KRR2.LV

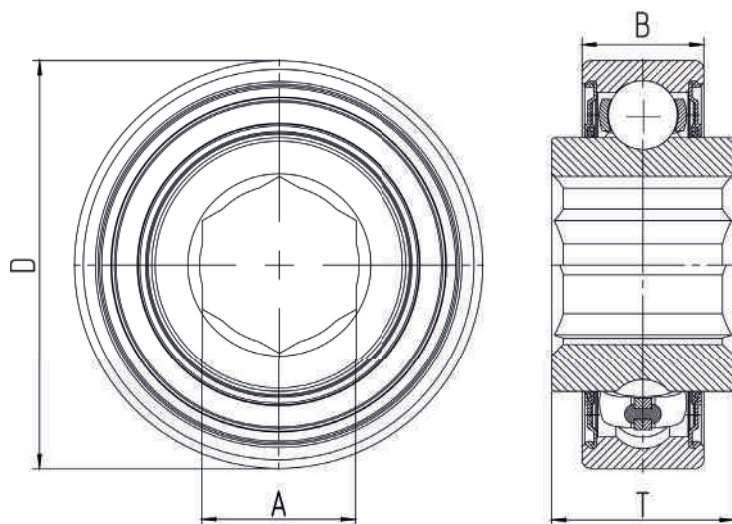

CROSS REFERENCE

Producer	OEM numbers
Timken	204KRR2
Koyo	88120A
NTN	1AH04-11/16
BCA	HPC011GPN
Link Belt	11KB204N
Massey Ferguson	PS01102
John Deere	JD7126
John Deere	AXE10322
John Deere	AH107148
Great Plains	822-128C
Great Plains	822-173C
AGCO	711770

Designation BBC-R	Application	Bore type	Description	A	D	T	B
204KRR2.LV	Head – Insert and special bearings	Hexagonal bore bearing	Harvesting / Combine harvester – Head	17,65	47	20,96	14

207KRRB9.LV

CROSS REFERENCE

Producer	OEM numbers
Timken	207KRRB9
INA	207 KRRB AH09
INA	SK102-207-KRRB AH10
NTN	2AH07-1 1/8
BCA	HPS102GP
John Deere	AE29309
John Deere	JD9457
CNH	121602
CNH	80121602

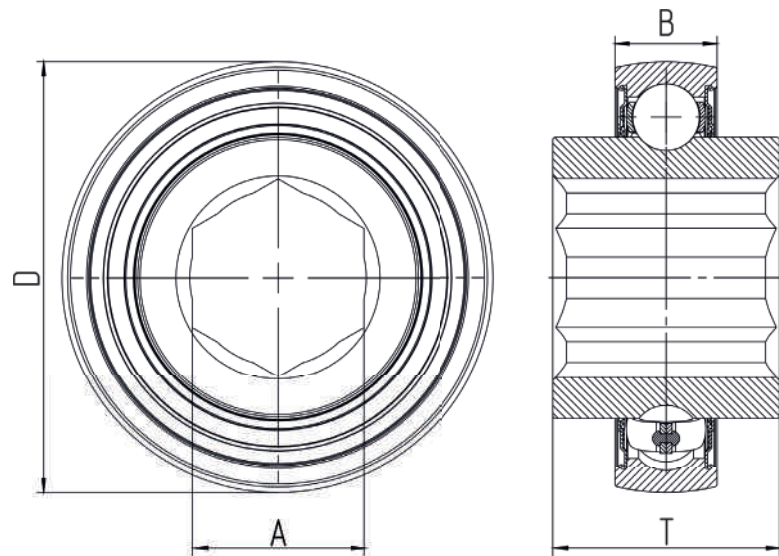

Designation BBC-R	Application	Bore type	Description	A	D	T	B
207KRRB9.LV	Head – Insert and special bearings	Hexagonal bore bearing	Harvesting / Combine harvester – Head	28,575	72	37,7	17

207KRRB12.LV

CROSS REFERENCE

Producer	OEM numbers
Timken	207KRRB12
Timken	207 KRRB12-H-A146
NTN	SBX 07A25 LLMC3Q1
NTN	SBX0762C4
BCA	HPS102GPE
John Deere	JD9488
John Deere	AN102010
CNH	87376564
CNH	86594423
CNH	84330069
CNH	156816C91

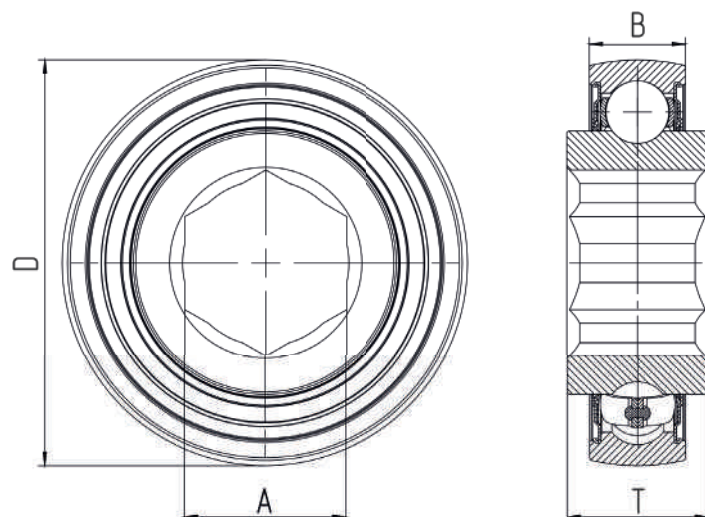

Designation BBC-R	Application	Bore type	Description	A	D	T	B
207KRRB12.LV	Pick-up – Special bearing	Hexagonal bore bearing	Harvesting /Baling – Pick-up	28,575	72	25	17

205KRRB2.LV

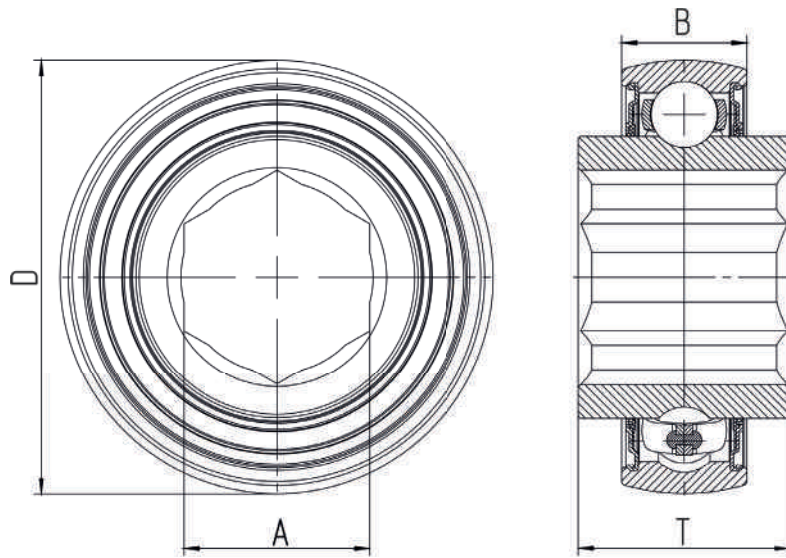

CROSS REFERENCE

Producer	OEM numbers
INA	205 KRRB AH02
INA	SK 014-205 KRRB
Peer	205KPPB54
Peer	205KRRB2
Timken	205 KRRB2C1
NTN	2AH057/8
CNH	195293C91
CNH	47508387
CNH	86900821
CNH	87650438
Great Plains	822-119C
Great Plains	822-195C
Great Plains	HPS014GP
John Deere	AA22097
John Deere	DQ06891
John Deere	JD22097
John Deere	JD9260
John Deere	N856695
Kinze	G210003
Kinze	G2100-03
Kinze	GA2100-03
Kinze	GA9357

Designation BBC-R	Application	Bore type	Description	A	D	T	B
205KRRB2.LV	Combine Straw Spreader and Auger Bed	Hexagonal bore bearing	Harvesting	22,5	52	25,4	15

206KPPB5.LV

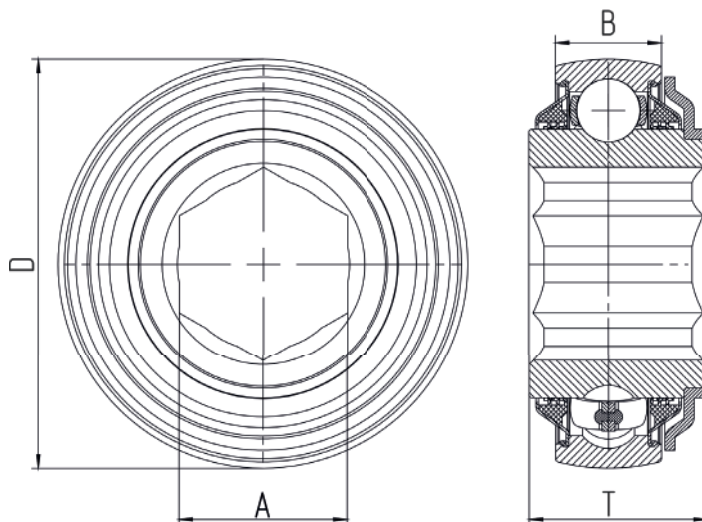

CROSS REFERENCE

Producer	OEM numbers
Timken	206KPPB5
John Deere	JD8673
BCA	HPS100TPD
Case	212328C91

Designation BBC-R	Application	Bore type	Description	d	D	T	B
206KPPB5.LV	Cotton Picker Auger and Idlers	Hexagonal bore bearing	Cotton Picker	25,425	62	26,9	16

209 KRR K/50.135.LV

CROSS REFERENCE

Producer	OEM numbers
INA	209 KRR K/50.135
FKL	209 KRR K/50.135

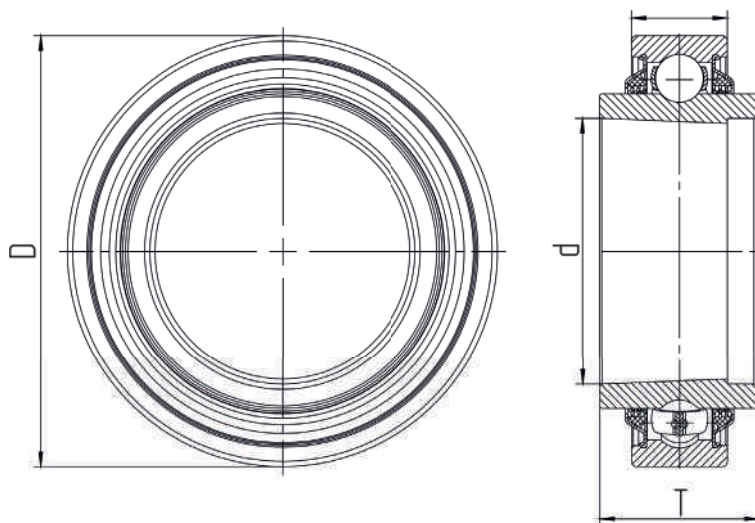

Designation BBC-R	Application	Bore type	Description	d	D	T	B
209 KRR K/50.135.LV	Combine harvester	Round bore bearing	Combine harvester	50,135	81	30	18

W308PP.LV

CROSS REFERENCE

Producer	OEM numbers
FKL	SL 40/90/36.5
Timken	W308PP-FS149
John Deere	AP19769

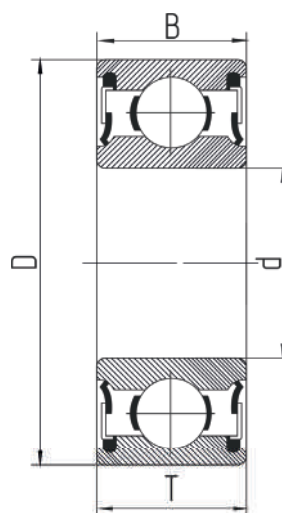

Designation BBC-R	Application	Bore type	Description	d	D	T	B
W308PP.LV	Combine harvester	Round bore bearing	Combine harvester	40	90	36,5	36,5

208KRR4.LV

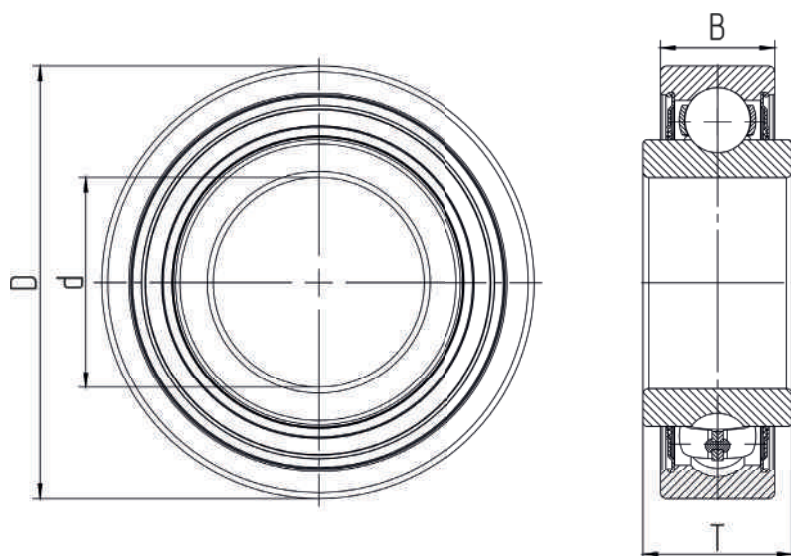

CROSS REFERENCE

Producer	OEM numbers
Timken	208KRR4
INA	208 KRR AH 04
INA	208 KRR AH 04 FA154
FAG	500928C
Koyo	88128
NTN	SBX08A53LMC3
BCA	208 TT2R
CNH	171110C9
CNH	272688
CNH	662519R91
John Deere	AH96585
John Deere	JD10087
John Deere	S15039
Ford	87TU1225AA
Massery Ferguson	486278M2

Designation BBC-R	Application	Bore type	Description	d	D	T	B
208KRR4.LV	Round baler – Insert and special bearings	Round bore bearing	Harvesting /Baling – Round baler	38,892	80	27,508	21

206KPP16.LV

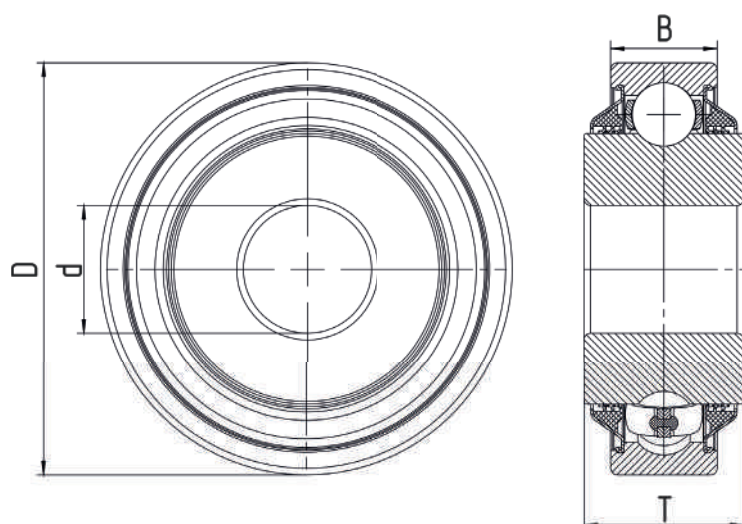

CROSS REFERENCE

Producer	OEM numbers
Timken	206KPP16
Timken	206KRR13
FAFNIR	NDH88X0442C3
PEER	206GGH
CNH	7012998
Orthman	120-070

Designation BBC-R	Application	Bore type	Description	d	D	T	B
206KPP16.LV	Square baler – Special bearing	Round bore bearing	Harvesting /Baling – Square baler	19,200	62	24	16

CROSS REFERENCE

Producer	OEM numbers
Timken	203KRR3
INA	203 KRR AH03
BCA	8984YYN
Allis Chalmers	5409594
Allis Chalmers	1126056
Allis Chalmers	70540959
CNH	126551C91
CNH	135052C91
CNH	165484
CNH	200646C91
CNH	47577176
CNH	493430R91
CNH	56617
CNH	667925R91
FORD	7000242
GEHL	W518146E
GEHL	505245E
John Deere	AE74534
John Deere	JD8571
John Deere	JD8646
Massey Ferguson	711770M
Massey Ferguson	834099M1

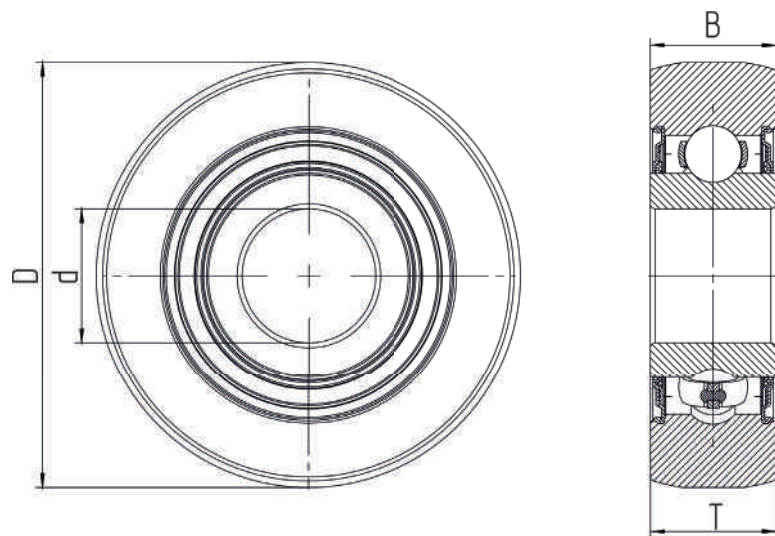

Designation BBC-R	Application	Bore type	Description	d	D	T	B
203KRR3.LV	Square baler – Special bearing	Round bore bearing	Harvesting /Baling – Square baler	16	50,8	15	15



Deep groove ball bearings



Deep groove ball bearings

Designation BBC-R	Application	Bore type	Description	d	D	T	B
1726203 2RS.LV	AQX110409 John Deere 832009M1 Massey Ferguson	Round bore	Combine harvester	17	40	12	12
1726204 2RS.LV	826922C91 CNH 824933C91 CNH PMS204FF John Deere 353152X1 Massey Ferguson	Round bore	Combine harvester	20	47	14	14
1726205 2RS.LV	80034439 CNH 340411236 Laverda 831112M1 Massey Ferguson	Round bore	Combine harvester	25	52	15	15
1726206 2RS.LV	340411237 CNH JD10386 John Deere VF06215766 Kverneland	Round bore	Baler Combine harvester	30	62	16	16
1726207 2RS.LV	308803 CNH 3155950R91 CNH 1407629R91 CNH 1410249R91 CNH 1415467R91 CNH 3166063R91 CNH 233544.0 Claas F04100012R Gaspardo 025121 Geringhoff 4655.1 MONOSEM 831822M1 Massey Ferguson 832939M1 Massey Ferguson	Round bore	Baler Combine harvester Corn head Forage harvester Mower	35	72	17	17
1726208 2RS.LV	730004600 LUK AZ23315 John Deere	Round bore	Baler Combine harvester Corn head	40	80	18	18
1726209 2RS.LV	02103200 CAPELLO 212102.0 Claas LA340411277 Massey Ferguson	Round bore	Combine harvester Corn head	45	85	19	19
1726210 2RS.LV	JD33006 John Deere 658157M1 Massey Ferguson DR3290 Olimac Drago	Round bore	Baler Combine harvester Corn head	50	90	20	20
1726309 2RS.LV	F04010225 Gaspardo	Round bore	Combine harvester Corn head	45	100	25	25
1726310 2RS.LV	71154722 Massey Ferguson	Round bore	Combine harvester Corn head	50	110	27	27



Attachment and trailer wheels

Tapered roller bearings

**Transport wheels / implements of
soil cultivation and sowing machines**

Apart from the working bodies of sowing and soil cultivation machines, bearings are also used in the hubs of transport wheels and attachments. Metric and inch series tapered roller bearings are most commonly used in this type of hub unit.



Operating conditions

- Combined radial and axial loads
- Shock loads
- High speeds of movement of the machine (to ensure high performance)

Transport wheel solution

For use in transport wheel hubs, implement wheel hubs, BBC-R offers a wide range of tapered angular contact bearings in pairs to handle high axial and radial loads.

Designation	Bore / shaft diameter	Bore type	D	T
LM11949/LM11910	19.050	Round	45.237	15.494
LM12749/LM12710	22	Round	45.237	15.494
L44643/L44610	25.400	Round	50.292	14.224
L44649/L44610	26.988	Round	50.292	14.224
LM67048/LM67010	31.75	Round	59.131	15.875
15123/15250	31.75	Round	63.5	19.478
15126/15250	31.75	Round	63.5	20.638
2790/2720	33.338	Round	76.2	23.774
LM48548/LM48510	34.925	Round	65.088	18.034
25877/25821	34.925	Round	73.025	23.812
L68149/L68111	34.988	Round	59.975	15.875
30207	35	Round	72	18.25
JL69349/JL69310	38.1	Round	62	17
LM29749/LM29710	38.1	Round	65.088	18.034
LM501349/LM501310	41.275	Round	73.431	9.558
342A-d2/332	41.275	Round	80	28.575
25580/25520	44.45	Round	82.931	23.812
HM803149/HM803110	44.45	Round	88.9	30.162
460/453A	44.45	Round	107.95	27.783
33109	45	Round	80	26
LM102949/LM102910	45.242	Round	73.431	19.558
LM603049/LM603011	45.242	Round	77.788	19.842
25590/25520	45.618	Round	82.931	23.812
LM503349/LM503310	46	Round	75	18
JLM104948AA/ JLM104910AA	50	Round	82	21.5
LM104949/LM104911	50.8	Round	82.55	21.59
3780/3720	50.8	Round	93.264	30.162
33889/33821	50.8	Round	95.25	27.783
JLM506849/JLM506810	55	Round	90	23
387AS/382A	57.15	Round	96.838	21
45289/45220	57.15	Round	104.775	30.162
39585/39520	63.5	Round	112.712	30.162
HM212049/HM212011	66.675	Round	122.238	38.1
HM218248/HM218210	89.974	Round	146.975	40

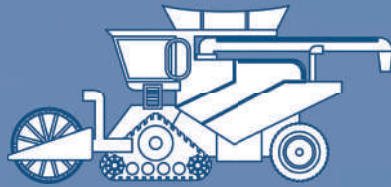

AGRO-HUB

Maintenance-free hub assemblies are interchangeable with standard bearing assemblies used in soil cultivation machinery. Their design allows for shorter service times. Also, this type of hub assemblies has an increased degree of protection against pollution and corrosion, which increases the service interval and generally improves the performance of the implements.

Advantages

1. Long hub's life
2. High loading capacity
3. Maintenance free option helps to extend service life and cut operating costs.
4. Zinc-coated flange surface.
5. Corrosion resistant.
6. Easy mounting and replacement.

Recommended working conditions

Tractor speed 5 - 20 km/h

Operating temperature range from -20 to 50 degrees Celsius

Can be used on discs up to 630 mm in diameter.



BEARING UNITS BBC-R AGRO HUB

The agricultural market is a constantly developing segment of mechanical engineering.

There are strict requirements to agricultural machinery in part of its performance, durability and stability. To comply the current trends in the industry development, **Baltic Bearing Company** has put into production a new series of products - BBC-R AGRO HUB bearing units. They are intended for operation in various types of agricultural machinery.

These hubs are a complex high-tech solution that does not require maintenance or repair during their entire life cycle. This solution saves time and costs.

ADVANTAGES:

- The original design of the three-lip cassette seal in combination with the spring-loaded working lip of the additional dust boot and the protective cover reliably protects against the penetration of contaminants and moisture from the external environment.
- An innovative design based on an angular contact ball bearing with forged flange increases the rigidity of the bearing, prevents its deformation during installation and operation, and guarantees stable operation of the unit.
- Increased shock loading and 20% higher load capacity compared to option with double row angular contact ball bearing in steel housing.
- Absence of necessity for relubrication increases service life and minimizes operating costs.
- Easy to mount and replace.

1. Bushing (protects against mechanical damage)

2. hree-lip seal (additional protection against ingress of large contaminants)

3. Spring-loaded lip with additional seal (additional protection against the ingress of small contaminants).

PRODUCTION

The BBC-R AGRO HUB is produced in Latvia.

Turning, grinding of housings and bearing parts, and assembly of the BBC-R AGRO HUB are carried out in strict accordance with European quality standards.

BBC-R AGRO HUB bearing units are produced on the basis of BBC-R angular contact ball bearing. These bearings are supplied to numerous agricultural machinery manufacturers.

BBC-R AGRO HUB bearing units have successfully passed life tests under real operating conditions.

APPLICATION

BBC-R AGRO HUB is used in various types of agricultural machinery: cultivators, harrows, rippers, seeding complexes, etc.

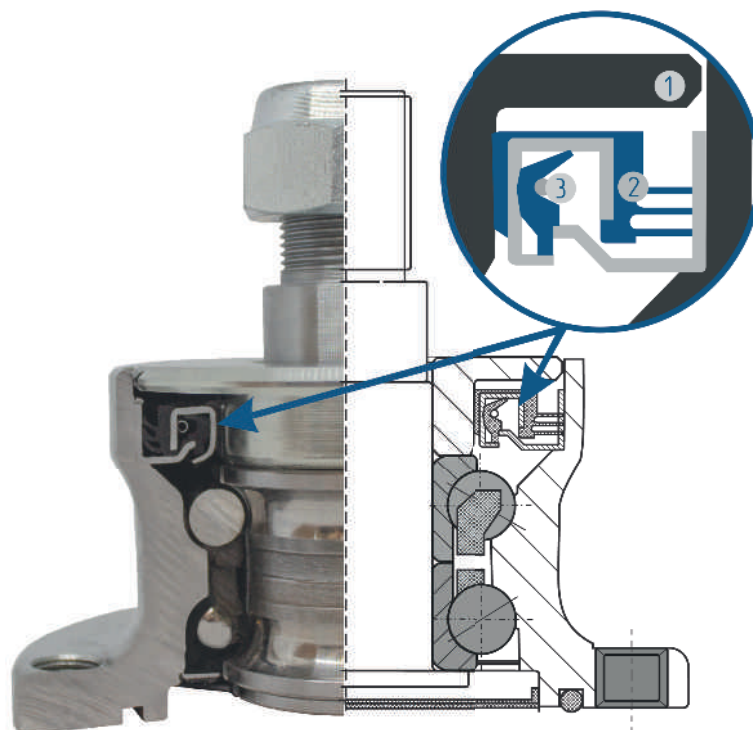

BAA-0003.LV

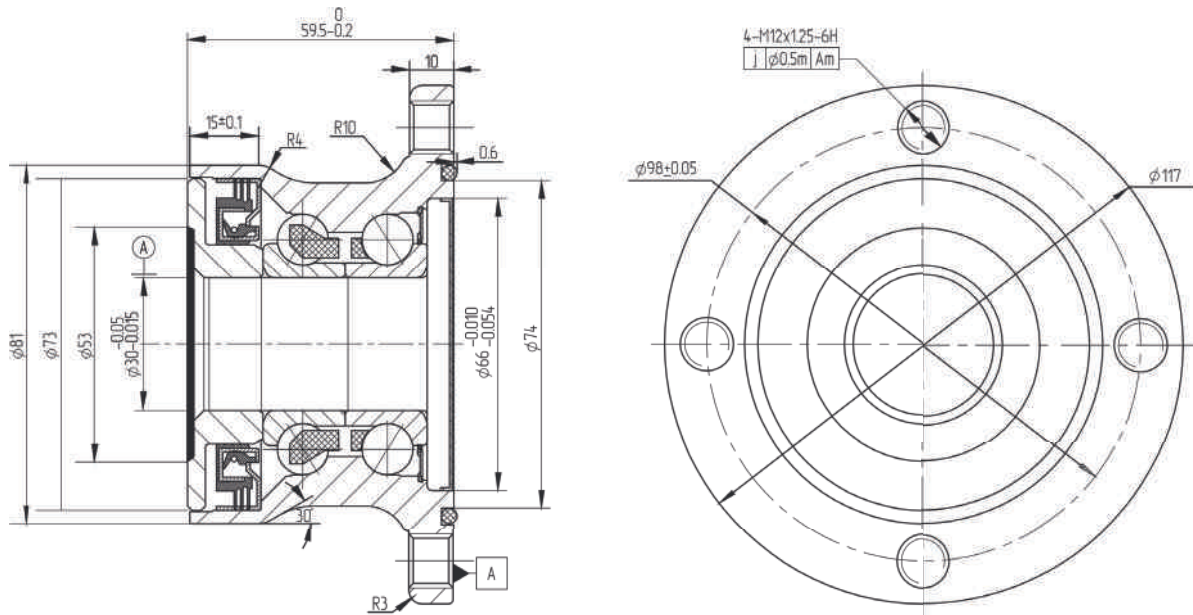

BAA-0004.LV

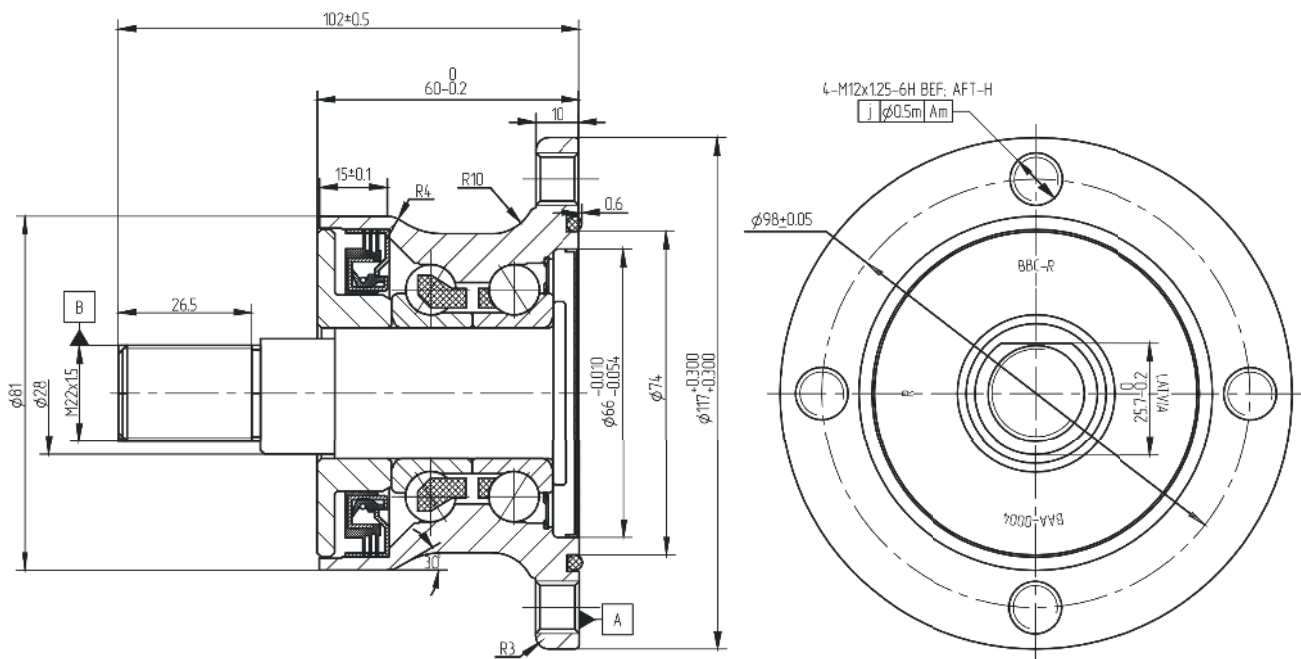

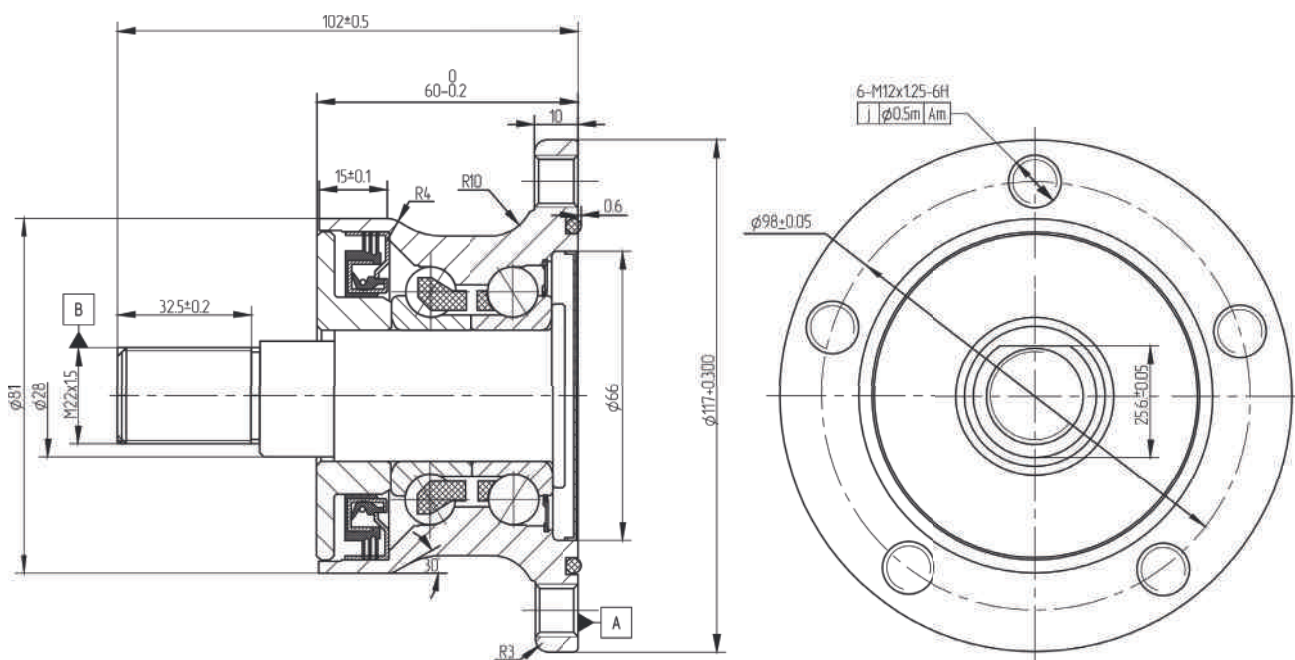
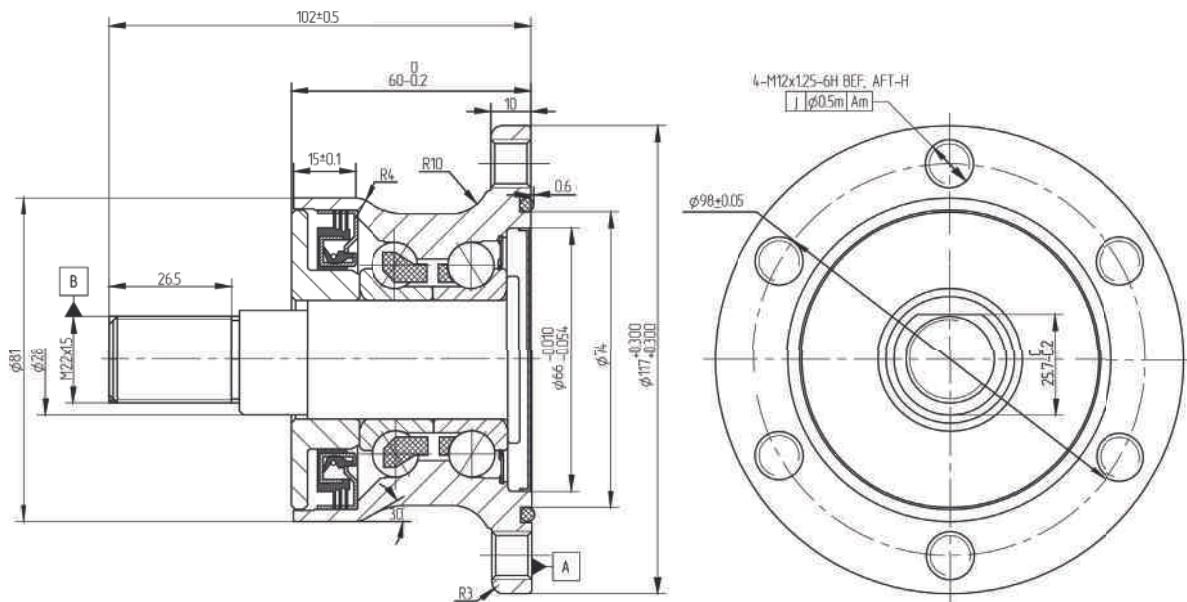

Advantages for machine manufacturers

Factor	Description	Savings
Development	In addition to standard ranges, BBC-R offers solutions for specific customers and applications. The machine manufacturer does not need to invest in in-house development.	Engineering capacity, development costs
Testing	Thanks to experience and core specialisms such as seal technology, bearing design and the development of bearing assemblies there is no need for extensive tests on individual components and assemblies. The use of tried and tested technology provides additional safeguards.	Engineering capacity, test benches – in some cases for individual components as well – field testing
Procurement and logistics	Clients source a complete solution. There is no need for different suppliers and individual components to be audited and approved. Storage and materials planning for these individual components is also eliminated.	Purchasing and procurement capacity, storage
Assembly	There is no time-consuming assembly of various individual components: the Hub Units is mounted straight to the machinery.	Assembly time
Guarantee	Defect analyses, diagnostics, etc. become superfluous.	Defect analyses, repairs, guarantee

Advantages for farmers

Factor	Description	Savings
Productivity	No need for repairs due to bearing failures caused by insufficient lubrication and contamination. This increases the machinery's availability.	Downtime, spare parts, repair service
Contamination	Field tests have proved that the cassette seal developed specially for the HUB units provides reliable protection from contamination such as clay, sand, dust, plant fibres, liquid manure and other fertilisers, water and moisture ingress. The cassette seal is also protected from stones by a steel disc.	Bearing failures caused by contamination (increases service life in several times*)
Lubrication/grease	HUB units are sealed bearing units with lifelong lubrication. This means there is no need for regreasing.	Saves time and prevents grease leakage in the field.
Assembly	There is no time-consuming assembly of various individual components: the Hub Units is mounted straight to the machinery.	Assembly time
Guarantee	Defect analyses, diagnostics, etc. become superfluous.	Defect analyses, repairs, guarantee

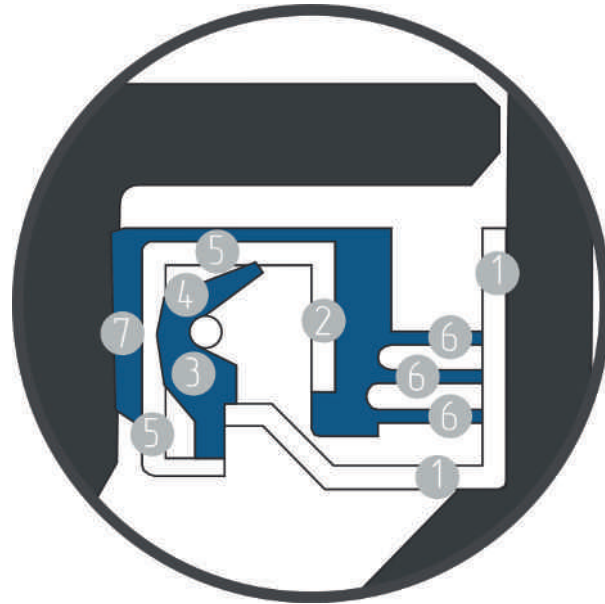

1. Metal outside frame.

Outside diameter metal frame Improves static sealing. Heat dissipation and retention in housing.

5. Integrated counterface

The spring-loaded main sealing lip keep the sealing lips lubricated and promote sealing ability regardless of rotation direction. This results in less friction and wear for extended service life.

2. Bumper

The bumper positions the sleeve relative to the seal to balance the right interference for the axial lips. It also acts as a line of defence against contaminants.

6. Multiple sealing lips

Pre-greased auxiliary radial and axial lips support the main lip for maximum protection against liquid or solid contaminant ingress.

3. NBR rubber

This standard HUB sealing lip material is a nitrile rubber compound. It helps reduce wear and ageing. this advanced material is compatible with most synthetic oils.

7. Full rubber inside diameter

Contributes to effective static sealing ,and helps reduce the assembly force ,required for installation.

4. Main lip

The spring-loaded main sealing lip keep the sealing lips lubricated and promote sealing ability regardless of rotation direction. This results in less friction and wear for extended service life.



The group of companies **Baltic Bearing Company**

sales@bbcr.eu

www.bbcr.eu





Traleru iela 2C, Riga, LV-1030, LATVIA
Phone: +(371)660-525-20

sales@bbcr.eu



www.bbcr.eu

© BBC-R is a trademark of BBC Group. © BBC Group 2021

The contents of this publication may not be reproduced (even extracts) unless permission is granted. Every care has been taken to ensure the accuracy of the information contained in this publication but no liability can be accepted for any loss or damage whether direct, indirect or consequential arising out of the use of the information contained here in.