



KINEX BEARINGS

ROLLING BEARINGS FOR RAILWAY VEHICLES



MORE THAN 100 YEARS EXPERIENCES
IN ENGINEERING AND BEARINGS PRODUCTION



REFERENCES

MANUFACTURERS

Astra Rail (RO), Bombardier Transportation (DE), Bonatrans (CZ), Greenbrier (PL), Gredelj (HR), Legios (CZ), Lucchini (IT), MAV Tiszavas (HU), Newag (PL), Škoda Transportation (CZ), Tatravagónka (SK)

RAILWAY COMPANIES

BR (GB), ČD Cargo (CZ), Deutsche Bahn (DE), HŽ (HR), MAV (HU), ÖBB (AT), PKP Cargo (PL), PKP Intercity (PL), SBB Cargo (CH), SZ (SI), ZSSK (SK), ZSSK Cargo (SK), ŽS (RS), AAE (CH), GATX (DE), VTG (DE), Touax (FR)



COMPANY PROFILE

Production program of the KINEX BEARINGS includes wide assortment of standard and special rolling bearings for different industrial branches. Production plants went through complicated historical development from their establishment and presently the KINEX BEARINGS with its large scale production program belongs to global producers of the rolling bearings.

Production of the rolling bearings has a long term tradition. KINEX BEARINGS offers complex services in the field of research, development and production of the rolling bearings and rolling elements. One of the most significant industrial segments in term of volume of sold bearings is the railway industry. Beginning of production in segment of single row roller bearings for the railway vehicles dates from year 1959. A commercial corporation KINEX BEARINGS, a.s. belongs at the moment to leaders in field of the roller bearings supplies for axles of the freight wagons in Europe and disposes of validations for different products supplies

needed for application of the above mentioned bearings in various territories. Production of the single row roller bearings that are used in railway industry is assured in accordance with requirements of the European standard EN 12080. KINEX BEARINGS, a.s. (Joint Stock Company) offers also deliveries of the bearing units for axles of the goods wagons with load on the axle 22.5 tons and axle load of 25 tons.

PRODUCT PORTFOLIO FOR RAILWAY ROLLING BEARINGS

- › bearings
- › axleboxes
- › tailor made services

APPLICATION OF BEARINGS

LOCOMOTIVES

- AXLE SEATINGS OF ELECTRIC AND DIESEL LOCOMOTIVES



- TRACTION MOTORS AND GENERATORS INCL. ELECTRICALLY INSULATED BEARINGS



- TRANSMISSIONS
- COMPRESSOR'S MOTORS, FANS MOTORS
- DRIVE OF BLOWERS EXCITERS AND CHARGING DYNAMOS OF ELECTRIC AND DIESEL LOCOMOTIVES



APPLICATION OF BEARINGS

TRAIN SETS AND WAGONS

- › BEARING UNIT FOR PASSENGER TRANSPORTATION CRU



- › AXLEBOXES AND ROLLER BEARINGS FOR PASSENGER CARS AND FREIGHT WAGONS



- › ROLLER BEARINGS FOR METRO AND TRAMS



FREIGHT WAGON AXLEBOXES

Axlebox BA 182

Bogie	Y 25
Axle load	22.5 tons
Cyl. roller bearing	PLC 410-33-2/34-2 (WJ/WJP 130x240)
Maximum speed	120 kmph
Suspension	helical coil springs
Box material	spheroidal grafite cast iron

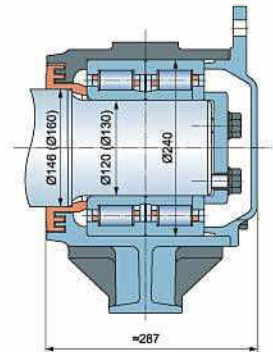
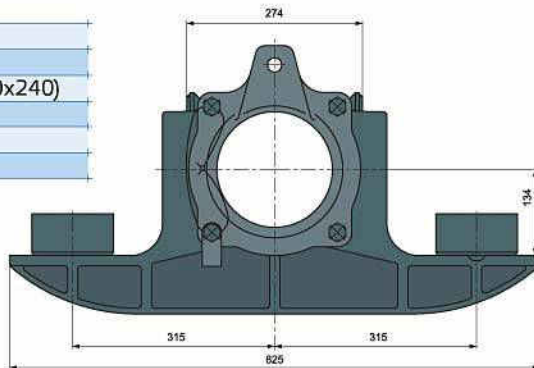

Axlebox BA 381

Bogie	2 and 4 axle goods wagon
Axle load 2	22.5 tons
Cyl. roller bearing	PLC 410-33-2/34-2 (WJ/WJP 130x240)
Maximum speed	120 kmph
Suspension	leaf spring
Box material	spheroidal grafite cast iron

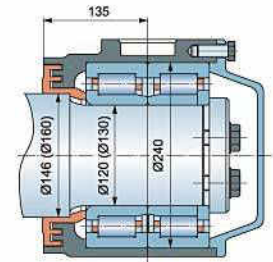
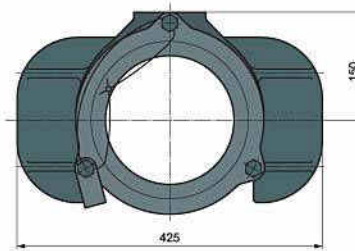

Axlebox 80 VM

Bogie	Y 25
Axle load	25 tons
Cyl. roller bearing	PLC 410-33-2/34-2 (WJ/WJP 130x240)
Maximum speed	120 kmph
Suspension	helical coil springs
Box material	cast steel

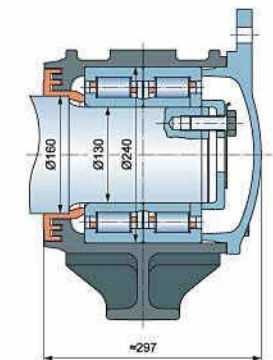
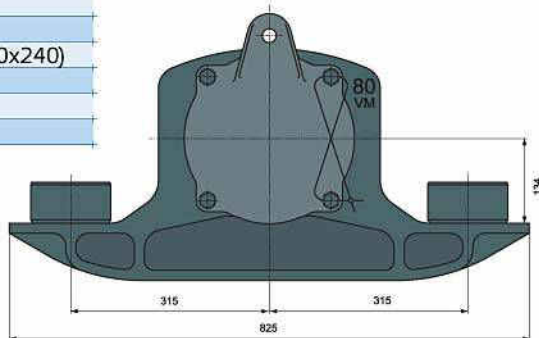

Axlebox BA 386 (02S)

Bogie	Y 25
Axle load	25 tons
Cyl. roller bearing	PLC 410-33-2/34-2 (WJ/WJP 130x240)
Maximum speed	120 kmph
Suspension	helical coil springs
Box material	spheroidal grafite cast iron

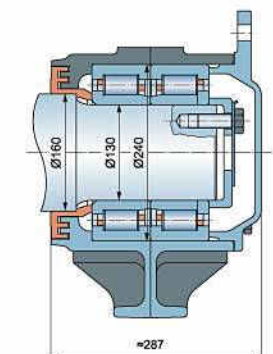
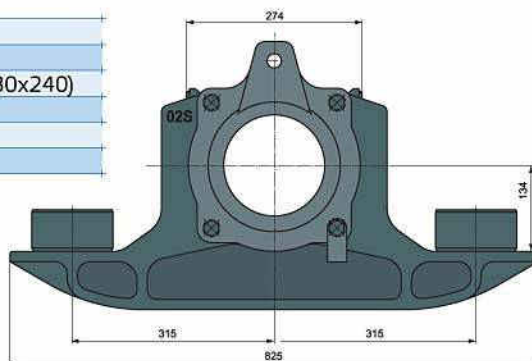

TRAININGS

ASSEMBLY TRAININGS, DISASSEMBLING AND MAINTENANCE OF CYLINDRICAL BEARINGS FOR RAIL VEHICLES

KINEX offers and provides professional trainings and practical demonstrations of assembling and disassembling of roller bearings for axle boxes of railway vehicles. The objective of these trainings is to train the staff of assembly plants in proper assembling of roller bearings which requires the use of correct procedures, tools, measurement fixtures and lubrications.



For this area, KINEX has a group of experienced technicians who are ready to solve the assembling and disassembling procedure on site or demonstrate their own assembling. Based on customer requirements, we performed professional trainings for rail vehicles of cargo transport, subway, urban transport and locomotives. The subject of the training is basic information about bearings made by KINEX, assembling and disassembling of bearings and maintenance of bearings.



RULES OF MOUNTING AND DISMOUNTING OF BEARINGS

WARMING UP OF BEARINGS INNER RINGS

Bearings of higher diameter series, used mostly in railway vehicles, require a bigger force to be pressed on at tight fitting. Therefore warming up of inner rings of bearings is used advantageously at the time of mounting them.

The bearings can be warmed up inductively or by air in electric furnace. Sufficient thermal expansion is achieved at the temperature 80–110 °C. The abutment dimensions of the axle journal and axlebox must be checked by measuring prior to bearings mounting procedure. The ring faces must be seated on their whole circumferences. Prior to mounting works it is necessary to check if the marking on the bearing is in conformity with the data on the drawing and at the list of parts.

Protection of contact surfaces and lubrication

Before fitting of the bearings it is advantageous to coat the contact surface of the axle journal and axlebox with a fine thin layer of L FAG 3 paste or with some other suitable agent in order to prevent rise of contact corrosion. At the time of mounting procedure, the bearings will be filled with a base grease, the brand and quantity of which is specified by the railway company with the consent of the bearings manufacturer.

Conditions for assembling

Mounting works must be carried out at a dry and dustfree workplace. The bearings, axleboxes and accessories must be protected from humidity and dirtiness during storage, checking and mounting procedures.

Dismounting of the bearings

If the bearings are to be reused after dismounting, this procedure must be carried out professionally with the help of suitable jigs and in accordance with the beforehand fixed procedure at a dry and dustfree workplace.

Jigs used for dismounting

It is important to be careful about that, only the ring which is to be pulled off was caught by the extracting jig. The force needed for dismounting must not be in any case carried through the rolling elements, since it would cause damage of raceways.

REPLACEMENT OF SPHERICAL ROLLER BEARINGS BY KINEX'S CYLINDRICAL ROLLER BEARINGS FOR AXLES OF RAILWAY VEHICLES

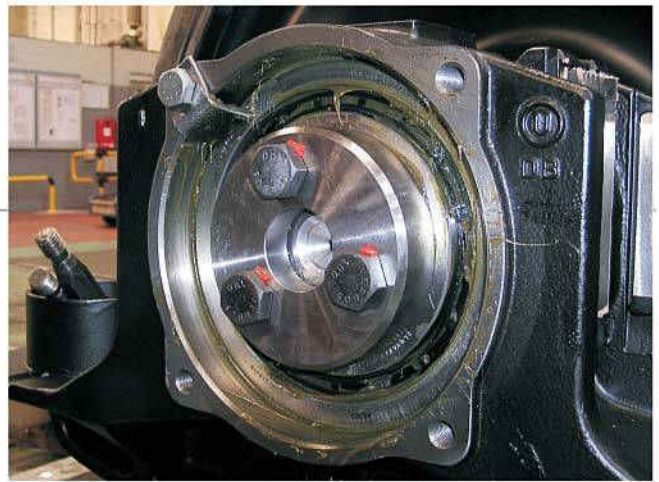

Roller bearings have been and are introduced due to their technical and service benefits as a better solution of rail vehicle axle imposition. Therefore, there are continuously deployed into operation and as a replacement of spherical bearings.

Currently, from all spherical bearings, there are only bearings with dimensions 130x220x73 mm used in railway transports.

Based on the interest of European railways, KINEX BEARINGS, a.s. has developed and integrated into production roller bearings with identical dimensions and designation PLC 410-223-2/224-2, which may be used as a replacement for spherical bearings.

Principally, the replacement of spherical bearings with roller bearings should not be taken just as a mutual replacement of bearings without an impact on their internal loading in relation with various types of bearing boxes.

The way of ensuring of the functionality of the roller bearings (for instance respecting of the axial clearance) requires a qualification of bearing boxes (with tightening of lids onto the firmly anchored or continuous screws) and supplementing of the bearings with spacing rings as at the spherical bearings for two alternatives of length of the wheelset pins (191 mm and 217 mm).

TECHNICAL BENEFITS

They mainly lie in:

- At roller bearings the ring orbits and cylindrical surface of the cylinders are loaded by radial force F_r only and the axial forces F_a , which act shortly, i.e. there are transferred between the roller heads and supporting heads of the rings when driving through rail switches and curves, so they do not affect the bearing lifetime (see Fig. 1)
- At spherical bearings, both forces load the rolling surfaces of rings and spherical bodies (see Fig. 2)
- Roller bearings can also be used at high velocities, spherical bearings cannot be used in these cases
- The construction of roller bearings allows use of easier and less demanding assembling and disassembling of imposition.

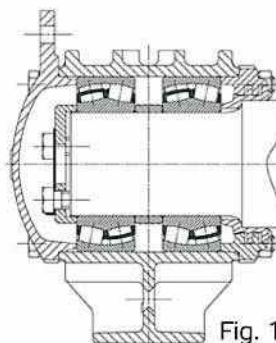

Fig. 1

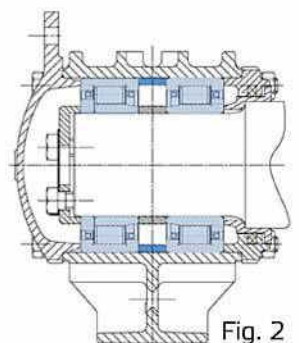
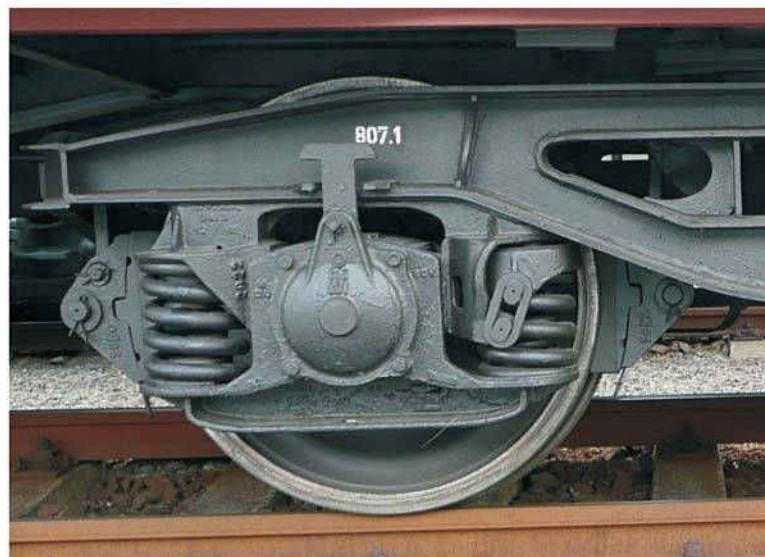

Fig. 2

ECONOMIC BENEFITS

- Reduction of work intensity for service processes (assembling/disassembling)
- Significant time savings when assembling and disassembling in comparison with spherical bearings, i.e. saves up to 60% of required time!
- Cost reduction of bearing replacement by 20 %
 - For roller bearings, a replacement of individual components (bearing block – external ring, rollers, cage, inner rings, lean-ring)
 - Interchangeability of inner rings of cylindrical roller bearings
 - Replacement of whole bearing for spherical bearings
- When disassembling spherical roller bearings, the operator of repair shall comply with a specific regime, special fixture to squeeze the bearings, usage of special hydraulic device (oil pressure) => a big impact on the compliance with strict safety and health protection, environmental protection, what represents increased costs.



RECONDITIONING OF ROLLING BEARINGS FOR RAIL VEHICLES

Reconditioning is defined as a process of maintenance to extend the operational capability and lifetime of the bearings which were already used.

Reconditioning is defined as a change of geometry and shear stress, which is realized by removal of stressed material volume and/or a replacement of rolling elements by a new set of bodies or rings, respectively.

Due to the qualified reconditioning process, KINEX BEARINGS is able to provide its customers with following benefits:

- Reduction of maintenance costs
- Extending of operational life of bearings
- Improving of overall reliability of rail vehicles
- Shortening of delivery times
- Solving of disposal process (scrap)
- Reduced environmental impacts
- through recycling of bearings

Analysis of cost showed that the re-instating of roller bearings, in compa-



Level 0. – Diagnostics of a bearing block* or a bearing

*a bearing block – an assembly of external ring+cage+roller bodies

This level includes the inspection of used bearings (appearance, operation), cleaning, disassembly, dimensional control and control of bearing properties (dimensions in accordance with drawings, hardness), processing of the protocol (a recommendation of suitable repair level). Bearings with high level of wear (for instance damage of raceway due to the fatigue of material under surface, cracks, pitting) are not included into reconditioning process...

Depending on the wear degree (surface damage caused by particles which cannot normally be given to the previous state by superfinish or grinding, respectively), the repair is divided into the following three levels:

Level I. – Basic reconditioning (maintenance) of a bearing block

This also includes all operations of level 0 and next operations:

- Corrosion removal (polishing and cleaning of functional and non-functional ring surfaces)
- Inspection of the ring by a non-destructive test
- Cleaning of the ring
- Re-assembling, in case of need a change of new cage or exchange of brass cage with a new plastic cage
- Demagnetizing and cleaning of bearing block
- Preservation
- Packaging

Level II. – Reconditioning of a bearing block

This level incl. all operations of level 0 and further operations:

- Corrosion removal (polishing and cleaning of functional and non-functional ring surfaces)

risson with purchasing of the new ones, achieves a potential of savings which can be found in interval between 50 up to 80%. It depends on the complexity and condition of each bearing.

A roller bearing cannot be used indefinitely. Sooner or later, a fatigue of material will appear. Operating lifetime of bearing is the number of rotations which one ring makes to another ring and load until fatigue of material appears on one of rings or rolling element. The analysis and experience gained by qualified reconditioning show that the reconditioned bearings can achieve almost identical lifetime and reliability in comparison with new bearings.

KINEX BEARINGS performs the reconditioning according to M 6328 standard, specifications Ril 984.0400 and VPI 04 for own axle bearings (ZVL, ZKL, KINEX) and also reconditioning of unified structure branded SKF Germany, SKF Poland (since 1972), FAG, NTN, KRW, Jaeger, FTL Poland (since 1972).

Depending on the use, the degree of bearing wear and analysis of used bearings, KINEX BEARINGS, a.s. offers several levels of bearing reconditioning.

- Superfinish (polishing) of raceways
- Inspection of the ring by a non-destructive test
- Cleaning of the ring
- Re-assembling including the replacement of a new cage or a change of new cage or exchange of brass cage with a new plastic cage
- Demagnetizing and cleaning of bearing block
- Preservation
- Packaging

Level III. – Reconditioning of a bearing block

This level includes all operations of level 0 and further operations:

- Grinding of cylindrical ring diameter / Corrosion removal (polishing and cleaning of functional and non-functional ring surfaces)
- Grinding of raceways
- Super finish (polishing) of raceways
- Inspection of the ring by a non-destructive test
- Cleaning of the ring
- Re-assembling including the replacement of a new cage or a change of new cage or exchange of brass cage with a new plastic cage including new rollers
- Demagnetizing and cleaning of bearing block
- Preservation
- Packaging

Level IV. – Reconditioning/repair of a bearing

This level includes all operations of level 0, in case of need also the operations I. up to III. and following operation:

- New ring installation

Clearly identified procedures and classification ensure that the bearing after reconditioning meets defined operational standards.



RESEARCH AND DEVELOPMENT

An important factor of quality improvement of cylindrical roller bearings is continuing design improvement that optimises lubrication, increases loading capacity and minimizes edge stresses.

KINEX BEARINGS HAS BEEN GIVING CONTINUOUS ATTENTION TO

- new products development
- present products improvement

INSPECTION AND TESTING

The production of axlebox cylindrical roller bearings used in railway industry is assured in accordance with requirements of european standard EN 12 080.

Rig performance tests of axlebox cylindrical roller bearings according to EN 12082, UIC515-5

Axle load 22,5 tons, speed 120 km per hour
Axle load 16 tons, speed 200 km per hour
Axle load 25 tons, speed 120 km per hour



CONTINUING DESIGN IMPROVEMENT INCREASES BEARING'S LIFE AND RELIABILITY

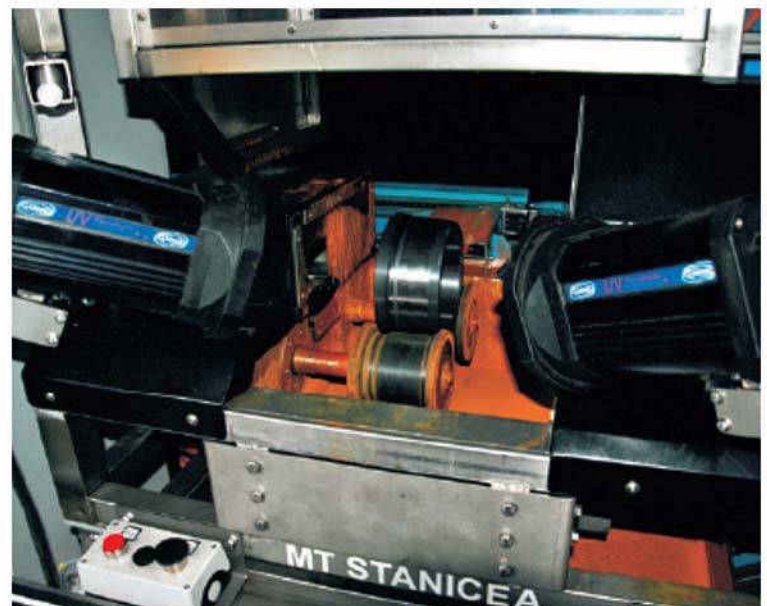



STANDARD SPECIFICATIONS

STANDARDS

- STN EN 12080 Railway vehicles; Axle boxes; Rolling bearings
- STN EN 12081 Railway vehicles; Axle boxes; Plastic lubricants
- STN EN 12082 Railway vehicles; Axle boxes; Performance test
- STN EN ISO 683-17 Steel intended for heat treatment; Alloyed and free cutting steel
Part 17: Steel for the rolling bearings
- STN EN 1982 Copper and copper alloys. Ingots and castings
- STN EN 12420 Copper and copper alloys. Forged pieces
- ISO 28 1 Rolling bearings. Dynamic load carrying capacity and durability
- ISO 76 Rolling bearings. Static load carrying capacity

QUALITY MANAGEMENT



Production plants of the KINEX BEARINGS are certified in accordance with standard ISO 9001, IRIS, ISO/TS 16 949, ISO 14 001 and OHSAS 18001 for the field of development and production of the roller and ball bearings by a certification Company 3EC International.

Development and manufacturing of bearings has established and maintains a quality management system according international railway industry standard (IRIS). Because of the amount of all certificates we work simultaneously on a complex quality management system that will allow us to joint the mutual requirements of those standards with effective implementation of other requirements.

QUALITY CERTIFICATES

- // ISO 9001
- // IRIS
- // ISO/TS 16 949
- // ISO 14 001
- // TS1





TECHNICAL DATA

OF ROLLING BEARINGS FOR THE RAILWAY VEHICLES

Rolling bearings used in production of railway vehicles are produced in standardized types ISO and also as special single row cylindrical roller bearings. The main advantages of cylindrical roller bearings usage are their simple design, easy assembly, easy maintenance and reliability in operation. Cylindrical roller bearings are characterized by low friction resistance, low temperature, low component wear and high load rating.

ESSENTIAL CONDITION OF RELIABLE OPERATION OF CYLINDRICAL ROLLER BEARINGS IS OBSERVANCE OF MOUNTING AND DISMOUNTING PRINCIPLES:

- › fitting tolerances
- › shape deviations
- › warming up of bearings (inner rings)
- › qualified mounting workplace
- › trained and qualified employees
- › using of suitable jigs
- › keeping of fixed procedures

Special single row cylindrical roller bearings used in axle railway vehicle seatings are produced with machined brass cage and glass-fibre reinforced polyamide cage. Reinforced polyamide cage improves reliability and safety. Single row cylindrical roller bearings in design NU, NJ, NUP used in railway drive systems and traction motors are produced with machined brass cage version E.



MATERIAL

Structure of the steel after heat treatment:

Martensite in which the residual austenite varies in the range from 3 to 10 %. This residual austenite in axle bearings is $\leq 2\%$.

Hardness of the bearing rings after heat treatment is in the range:

58-64 HRC (dispersion of measured values between all rings of one bearing must not be more than 3 HRC). To assure dimensional stability through the whole operational period, the bearing rings for axle bearings are stabilized by means of heat treatment on 200 °C (S1).

Hardness of rollers after heat treatment is in the range:

60-65 HRC (dispersion of measured values between all rollers of one bearing must not be more than 4 HRC).

Bearing rings:

Chromium steel through-hardening in the whole cross section: 100 Cr6, 100 CrMnSi6-4

Bearing rollers:

Chromium steel through-hardening in the whole cross section: 100 Cr6, 100 CrMnSi6-4

Cages:

Polyamide cage: material Pa 66gf25 hZ

Machined brass cage: material CuZn40Pb2, CuZn37Al1, CuZn31MnAM, MS58Al

INTERNAL DESIGN

DESIGN OF ROLLER FACE AND GUIDE FLANGE

it optimizes lubrication of a contact zone in the contact area and thus it increases axial load carrying capacity of the bearing.

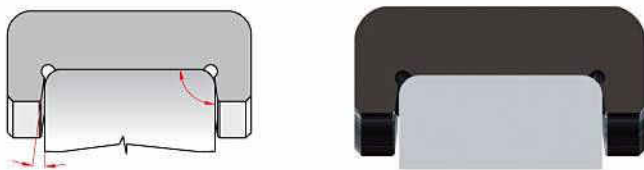

ZB PROFILE OF THE ROLLERS AND RACEWAY

it takes part on minimizing of the edge stress and thus also on increasing of durability and reliability of the bearing.

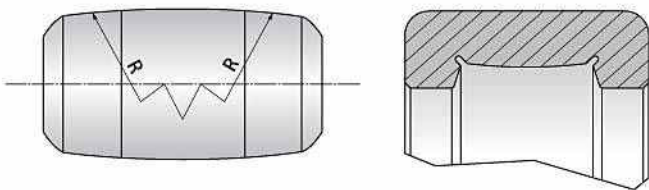

CONTACT EFFECTIVE STRESS

ZB optimizes the contact effective stress created on external and internal bearing ring.

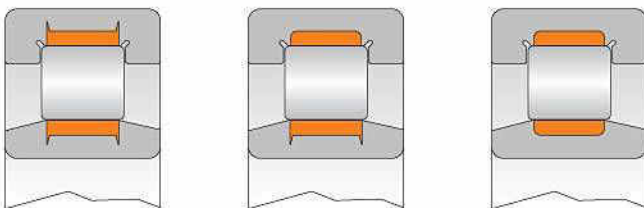

Cylindrical roller without ZB profile and non-convexed raceways of the rings

Roller ZB profile and raceway ZB profile of the outer ring. Non-convexed raceway of the inner ring

Roller ZB profile and convexed raceways of the rings (KINEX design)

LIFE CALCULATION

Single-row cylindrical roller bearings life calculation for railway vehicle axleboxes is based on the radial static load acting on the bearings of one wheel set i.e. axle load which is calculated from the equation:

$$G_1 = \frac{G}{n} \cdot G_2$$

where:
 G - weight of the vehicle (kN)
 G_1 - radial static load acting on one wheel set (axle load) (kN)
 G_2 - weight of a wheel set and others unsprung parts (kN)
 n - number of wheel sets

Then radial static load acting on one bearing will be:

$$P_{or} = \frac{G_1}{4}$$

where:
 G_1 - radial static load acting on one wheel set (kN) (axle load)
 P_{or} - radial static load acting on one bearing (kN)

Radial equivalent dynamic load acting on one bearing is calculated from the equation:

$$P_r = P_{or} \cdot f_d$$

where:
 P_r - radial equivalent dynamic load acting on one bearing (kN)
 P_{or} - radial static load acting on one bearing (kN)
 f_d - factor of additional forces (see table 1)

Factors of additional forces

Type of vehicle	f_d
Passenger carriages	1.2 to 1.3
Goods, self-discharging and ingot wagons	1.2 to 1.4
Locomotives	1.3 to 1.8

Basic bearing life can be calculated from the equation:

$$L_{10kmr} = \left(\frac{C_r}{P_r}\right)^{\frac{10}{3}} \cdot \pi \cdot D_k \cdot 10^{-3}$$

where:

L_{10kmr} - basic bearing life (10^6 km)
 C_r - basic radial dynamic load rating (see dimension tables) (kN)
 P_r - radial equivalent dynamic load acting on one bearing (kN)
 D_k - diameter of the vehicle wheel (mm)

BEARING ARRANGEMENT

INFLUENCE OF ARRANGEMENT ON BEARING LIFE

Bearing life is considerably influenced by arrangement of bearing rings on the shaft and at the housing. These parts should be manufactured with required quality and tolerances. According to the concrete operational conditions the rings are either push fitted (clearance fit) or force fitted (interference fit).

Essential condition for bearing arrangement is that the ring loaded on its circumference must be force fitted. Recommended values of shaft diameters and housing bore tolerances take into consideration all operational influences (type, direction and intensity of load, temperature ...) with loading during the whole workload time.

Recommended tolerances of journals diameters and housing bores

Arrangement	Journal diameter		Tolerance	Housing bore diameter	Tolerance
	Ball	Roller			
Fans	18 to 100	to 40	j6	Fans	J7
Generators	100 to 200	40 to 140	k6	Electric motors	K7
	18 to 100	to 40	k5		
Electric motors	100 to 200	40 to 140	m5	Traction motors	M7
	140 to 200	100 to 140	m6		
Axlebox bearings		50 to 140	*n6, p6	Axlebox bearings	H7
Traction motor bearings		140 to 500	*n6, p6	Axlebox bearings	H7

*It is necessary to use bearings with higher radial clearance at these arrangement.

Journal diameter tolerance limiting deviations

Journal nominal diameter mm		k5		m5		j6		k6		m6		n6		p6	
over	to	upper	lower	upper	lower	upper	lower	upper	lower	upper	lower	upper	lower	upper	lower
30	50	+13	+2	+20	+9	+11	-5	+18	+2	+25	+9	+33	+17	+42	+26
50	80	+15	+2	+24	+11	+12	-7	+21	+2	+30	+11	+39	+20	+51	+32
80	120	+18	+3	+28	+13	+13	-9	+25	+3	+35	+13	+45	+23	+59	+37
120	180	+21	+3	+33	+15	+14	-11	+28	+3	+40	+15	+52	+27	+68	+43
180	250	+24	+4	+37	+17	+16	-13	+33	+4	+46	+17	+60	+31	+79	+50

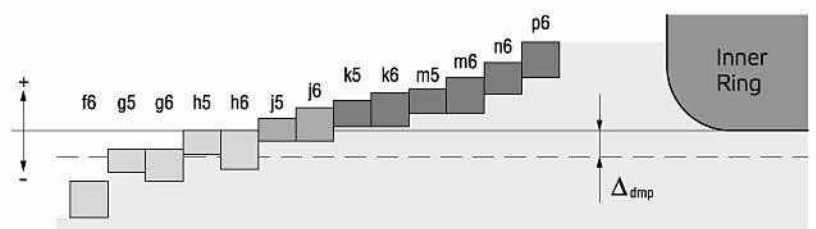

Bore diameter tolerance limiting deviations

Nominal bore diameter mm		H7		J7		K7		M7	
over	to	upper	lower	upper	lower	upper	lower	upper	lower
50	80	+30	0	+18	-12	+9	-21	0	-30
80	120	+35	0	+22	-13	+10	-25	0	-35
120	180	+40	0	+26	-14	+12	-28	0	-40
180	250	+46	0	+30	-16	+13	-33	0	-46
250	315	+52	0	+36	-16	+16	-36	0	-52
315	400	+57	0	+39	-18	+17	-40	0	-57

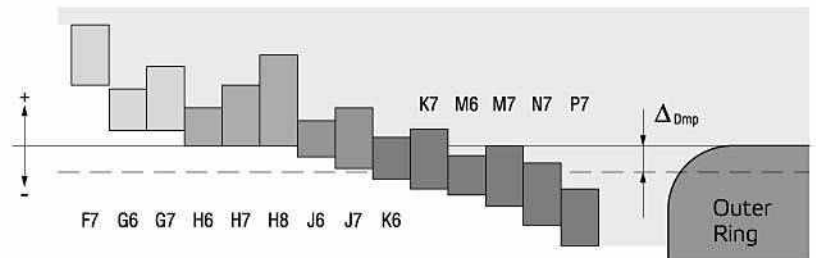

SHAPE DEVIATIONS

The further condition to achieve high bearing life in arrangements is to keep prescribed shape deviations of supporting areas and their surface quality. The shape deviations of supporting surfaces i.e. permissible deviation from roundness and cylindrical shape and permissible run-out of bearing surfaces with regard to the axle must be smaller than range of diameter tolerances.

Tolerance class	Place of arrangement from cylindrical shape	Permissible deviation	Permissible run-out of bearing surfaces with regard to the axle
P0, P6	shaft	IT 5/2	IT 3
P0, P6	shape	IT 6/2	IT 4

Values of standard tolerances IT

Nominal diameter mm		Tolerance class μm					
over	to	IT 2	IT 3	IT 4	IT 5	IT 6	
18	30	2.5	4	6	9	13	
30	50	2.5	4	7	11	16	
50	80	3	5	8	13	19	
80	120	4	6	10	15	22	
120	180	5	8	12	18	25	

Arrangement quality is influenced also by roughness of bearing supporting surfaces. These surfaces are smoothed at mounting procedures. Interface in the arrangement is more reduced if the surfaces are more roughness.

Supporting surface	Nominal diameter of the bearing	
	from 10 to 80	over 80
Shaft	0.63	1.25
Housing's bore	0.63	1.25
Face of journal shaft or housing	1.25	1.25

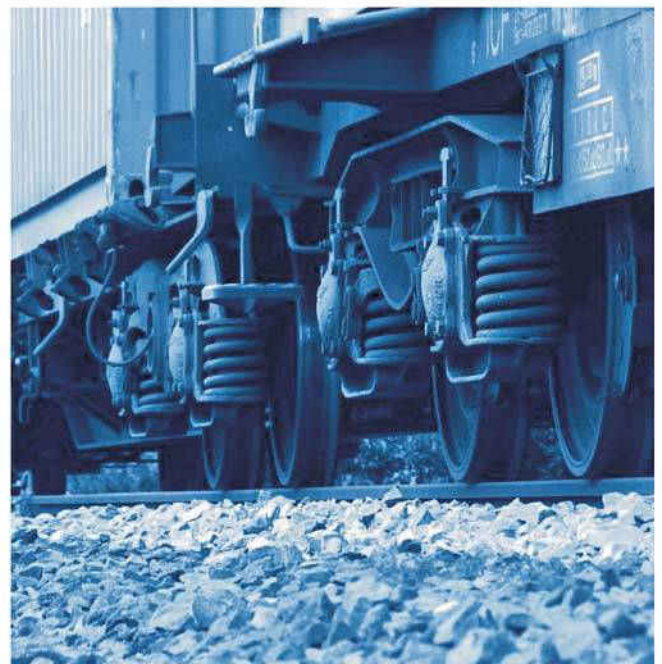

SINGLE-ROW CYLINDRICAL ROLLER BEARINGS

FOR AXLEBOXES

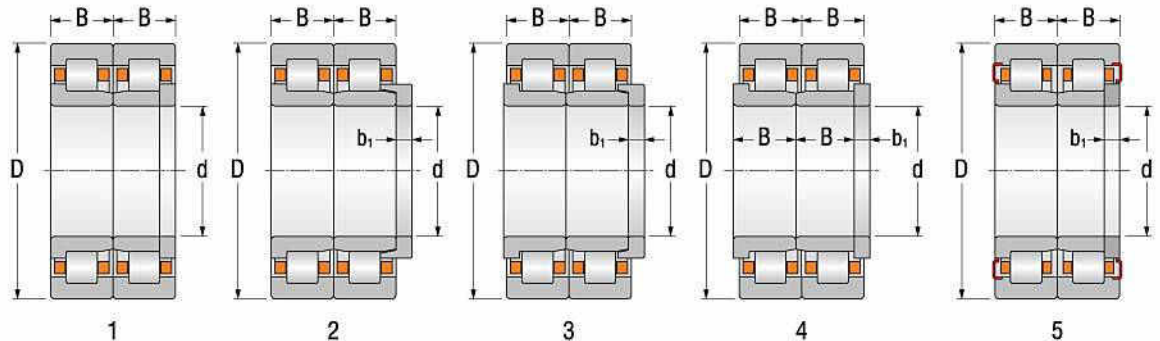

Dimensions				Basic load rating		Max. speed of railway vehicle	Weight of a pair of bearings	Bearings designation		Fig.	Cage
d	D	B	b ₁	dyn. cr	static cor						
mm				kN		km/hour	kg				
100	180	60.3	-	333.5	444.4	160	12	PLC49-200-2-1 (WJ100x180)	PLC49-201-2 (WJP100x180) ¹⁾³⁾⁴⁾	1	TNG
110	215	73	-	494.5	668.6	160	24.9	PLC410-207-1 (WJ110x215M)	PLC410-208-1 (WJP110x215M) ¹⁾⁴⁾⁵⁾	1	M
118	215	80	-	519.8	740.9	160	25.7	PLC410-213-3	PLC410-214-3 ¹⁾⁴⁾⁵⁾	1	M
	240	80	-	553.8	742.5	160	32.3	PLC410-13-2-3 (WJ118x240)	PLC410-14-2-3 (WJP118x240) ¹⁾³⁾⁴⁾	1	TNG
	240	80	-	553.8	742.5	160	34.2	PLC 410-23	PLC410-24 ¹⁾²⁾⁴⁾	1	M
119	240	80	-	553.8	742.5	160	32.1	PLC410-13-2-4 (WJ119x240)	PLC410-14-2-4 (WJP119x240) ¹⁾³⁾⁴⁾	1	TNG
119.3	240	80	-	553.8	742.5	160	31.7	PLC410-13-2-5 (WJ119,3x240)	PLC410-14-2-5 (WJP119,3x240) ¹⁾³⁾⁴⁾	1	TNG
120	200	62	-	372.8	549.1	120	16	PLC 49-202	PLC49-203 ¹⁾⁴⁾⁵⁾	1	M
	215	80	-	519.8	740.9	160	25.2	PLC 410-213	PLC410-214 ¹⁾⁴⁾⁵⁾	1	M
	240	80	-	553.8	742.5	160	33.7	PLC 410-13	PLC 410-14 ¹⁾²⁾⁴⁾	1	M
	240	80	-	553.8	742.5	160	33.7	PLC410-13-1 (WJ120x240M)	PLC410-14-1 (WJP120x240M) ¹⁾⁴⁾⁵⁾	1	M
	240	80	-	553.8	742.5	160	31.7	PLC410-13-2 (WJ120x240)	PLC410-14-2 (WJP120x240) ¹⁾³⁾⁴⁾	1	TNG
127	240	80	-	516.3	752.1	160	30.05	PLC410-15-2-5	PLC410-16-2-5 ¹⁾³⁾⁴⁾	1	TNG
128	240	80	-	516.3	752.1	160	30.28	PLC410-15-2-3	PLC410-16-2-3 ¹⁾³⁾⁴⁾	1	TNG
129	240	80	-	516.3	752.1	160	30.42	PLC410-15-2-4	PLC410-16-2-4 ¹⁾³⁾⁴⁾	1	TNG
	240	80	-	539.6	775.4	160	30.2	PLC410-33-2-4 (WJ129x240)	PLC410-34-2-4 (WJP129x240) ¹⁾³⁾⁴⁾	1	TNG
129.3	240	80	-	539.6	775.4	160	30.18	PLC410-33-2-9 (WJ129,3x240)	PLC410-34-2-9 (WJP129,3x240) ¹⁾³⁾⁴⁾	1	TNG
130	220	73	-	505.0	761.7	160		PLC410-223-2	PLC410-224-2 ¹⁾³⁾⁴⁾	1	TNG
	240	80	-	516.3	752.1	160	32.7	PLC 410-15	PLC410-16 ¹⁾²⁾⁴⁾	1	M
	240	80	-	516.3	752.1	160	30.65	PLC410-15-2 (WJ130x240)	PLC410-16-2 (WJP130x240) ¹⁾³⁾⁴⁾	1	TNG
	240	80	-	539.6	775.4	160	32.7	PLC410-33-1	PLC410-34-1 ¹⁾⁴⁾⁵⁾	1	M
	240	80	-	539.6	775.4	160	30.2	PLC410-33-2 (WJ130x240)	PLC410-34-2 (WJP130x240) ¹⁾³⁾⁴⁾	1	TNG
	240	80	-	539.6	775.4	200	30.6	PLC 410-215	PLC 410-216	5	TNG
	250	80	-	580.0	800.3	160	36.6	PLC 410-17	PLC410-18 ¹⁾²⁾⁴⁾	1	M
	250	80	-	580.0	800.3	160	34.2	PLC410-17-2	PLC410-18-2 ¹⁾³⁾⁴⁾	1	TNG
158	300	84	15	869.5	1214.3	160	58.3	PLC 411-200	PLC411-201 ¹⁾²⁾⁴⁾	2	M
159	300	84	15	869.5	1214.3	160	57.9	PLC 411-20	PLC411-21 ¹⁾²⁾⁴⁾	2	M
160	300	84	15	869.5	1214.3	160	57.5	PLC 411-10	PLC411-12 ¹⁾²⁾⁴⁾	2	M
180	320	86	12	713.5	1082.8	160	64.6	NJ2236M C4A450-900	NUG2236M C4 + HJ2236X16.33	2	M
	320	86	15	713.5	1082.8	160	64.9	NJ2236XM C4	NUG2236M C4 + PLC 810-1	3	M
	320	86	15	713.5	1082.8	160	64.9	NJ2236XMAS C4	NUG2236MAS C4 + PLC 810-1	3	MAS
	320	86	17	713.5	1082.8	160	64.8	NJ2236XM C4	NUG2236M C4+Angle ring NUP2236	4	M

¹⁾ Pair of bearings is marked shortly e. g. PLC 410-13/14

²⁾ Machined brass cage (steel riveted) or -1 (cross piece riveted)

³⁾ Glass-fiber reinforced polyamide cage, roller centred

⁴⁾ Inner ring interchangeable

⁵⁾ Two-piece machined brass pronged cage

M – two-piece machined brass cage, roller centred

MAS – two-piece machined brass cage with lubrication grooves, outer ring centred TNG – two piece polyamide cage

SINGLE-ROW CYLINDRICAL ROLLER BEARINGS

FOR LOCOMOTIVES

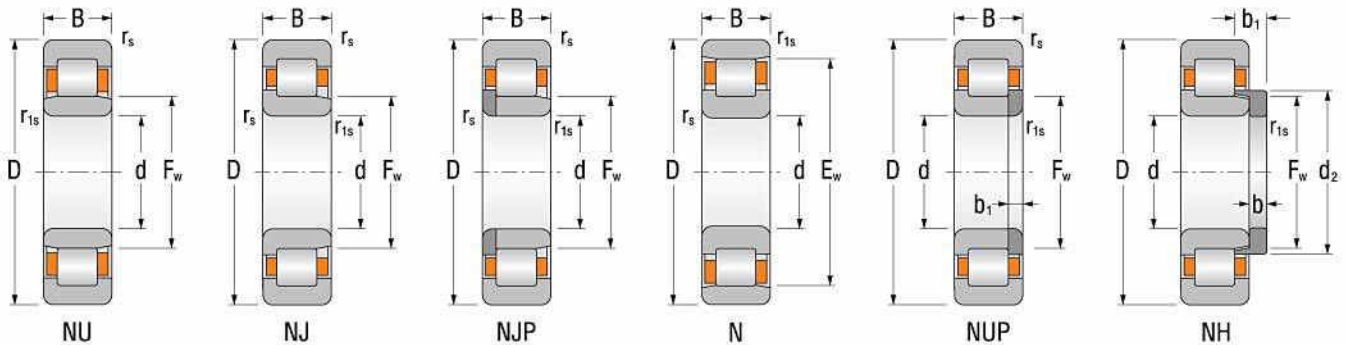

Dimensions			Bearings designation	Angle ring HJ	Basic load rating		Limiting speed for lubrication		Mass of		Dimensions						
d	D	B			dynamic C_r	static C_w	grease	oil	Bearing	Angle ring	$r_{s_{min}}$	$r_{1s_{min}}$	F_w	E_w	d2	b	b1
mm					kN		min ⁻¹		kg		mm						
90	190	43	NJ318EM	HJ318E	310.8	346.9	3 000	3 500	6.230	0.641	4	4	113.5	124	12	18.5	2
	190	43	NU318EM	HJ318E	310.8	346.9	3 000	3 500	6.229	0.641	4	4	113.5	124	12	18.5	2
	190	43	NJ318M	HJ318	234.9	258.4	3 200	3 800	6.070	0.667	4	4	115	125	12	21	2
	190	43	N318		234.9	258.4	3 200	3 800	5.250		4	4	165				2
	190	43	NU318M	HJ318	234.9	258.4	3 200	3 800	5.910	0.667	4	4	115	125	12	21	2
	190	43	NU318MA	HJ318	234.9	258.4	3 200	3 800	5.910	0.667	4	4	115	125	12	21	2
	190	43	NJ318	HJ318	234.9	258.4	3 200	3 800	5.520	0.667	4	4	115	125	12	21	2
	190	43	NU318	HJ318	234.9	258.4	3 200	3 800	5.360	0.667	4	4	115	125	12	21	2
	95	200	45	NJ319EM		328.9	378.5	2 800	3 300	7.170		4	4	121.5			
240		55	NJ419M		415.2	465.0	2 500	3 000	13.860		4	4	133.5				2.5
240		55	NU419M		415.2	465.0	2 500	3 000	13.570		4	4	133.5				2.5
100	215	47	NU320EMA		379.1	424.3	2 700	3 200	8.840		4	4	127.5				2
105	260	60	NJ421M	HJ421	515.1	585.1	2 200	2 700	17.620	1.740	4	4	144.5	159.7	16	27	2.5
	260	60	NU421M	HJ421	515.1	585.1	2 200	2 700	17.250	1.740	4	4	144.5	159.7	16	27	2.5
110	240	50	NJ322EM		439.6	507.6	2 400	2 800	12.006		4	4	143				2.9
	240	50	NU322EM		439.6	507.6	2 400	2 800	11.806		4	4	143				2.9
	240	50	NJ322M	HJ322	401.0	467.1	2 500	3 000	11.830	1.020	4	4	143	147.5	13	22.5	2.7
	240	50	NJ322MA		401.0	467.1	2 500	3 000	11.830	1.020	4	4	143	147.5	13	22.5	2.7
	240	50	N322M		401.0	467.1	2 500	3 000	11.420		4	4	207				2.7
	240	50	NU322	M HJ322	401.0	467.1	2 500	3 000	11.580	1.020	4	4	143	147.5	13	22.5	2.7
	280	65	NJ422M		569.5	654.7	2 100	2 500	22.350		4	4	155				2.7
	280	65	NU422M		569.5	654.7	2 100	2 500	21.880		4	4	155				2.7
120	260	55	NU324M		465.1	534.1	2 400	2 800	14.7		4	4	154		14		
	260	55	NJ324M		465.1	534.1	2 400	2 800	14.7		4	4	154		14		
	260	55	NUP324M		465.1	534.1	2 400	2 800	14.7		4	4	154		14		
	260	55	NH324M	HJ324	465.1	534.1	2 400	2 800	14.7	1.4	4	4	154		14		
	260	55	NU324EM		516.2	592.8	2 200	2 700	15.2		4	4	154				
	310	72	NU424M		714.4	834.5	1 900	2 200	30.59		5	5	170				
310	72	NJ424M		714.4	834.5	1 900	2 200	30.59		5	5	170					

¹⁾ Permissible axial displacement out of central position

E – bearings with higher load rating

M – two piece machined brass cage, roller centred

MA – two piece machined brass cage, outer ring centred

SINGLE-ROW CYLINDRICAL ROLLER BEARINGS

FOR LOCOMOTIVES

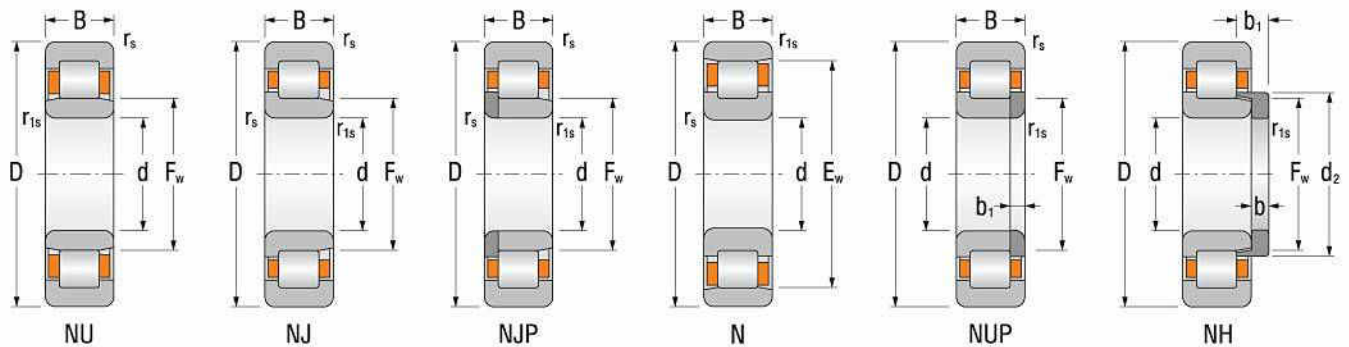

Dimensions	Bearings designation	Angle ring	Basic load rating		Limiting speed for lubrication		Mass of		Dimensions									
			dynamic	static	grease	oil	Bearing	Angle ring	$r_{s_{min}}$	$r_{1s_{min}}$	F_w	E_w	d_2	b	b_1	$s^{1)}$		
d	D	B	HJ	C_r	C_{rr}	min ⁻¹	min ⁻¹	kg	mm	mm	mm	mm	mm	mm	mm	mm	mm	
130	280	58	NU326EM	HJ326E	603.2	715.6	2000	2400	18.600	1.700	4	4	167		182	14	23	2.9
	280	58	NJ326EM	HJ326E	603.2	715.6	2000	2400	19.000	1.700	4	4	167		182	14	23	2.9
140	250	42	NJP228EMA		385.1	502.0	2300	2800	9.650		4	4	169					1.6
	250	42	NU228EMA		385.1	502.0	2300	2800	9.440		4	4	169					1.6
	250	42	N228M		318.3	410.5	2500	3000	8.897		4	4		221				2.5
	250	42	NUP228M		318.3	410.5	2500	3000	9.870		4	4	169					
	250	42	NJ228M		318.3	410.5	2500	3000	9.330		4	4	169					2.5
	250	42	NU228M		318.3	410.5	2500	3000	9.110		4	4	169					2.5
	300	62	NU328M		603.4	725.8	2000	2400	22.100		4	4	180					2.7
	300	62	NJ328M		603.4	725.8	2000	2400	22.840		4	4	180					2.7
300	102	NJ2328EM		1018.8	1384.5	1900	2200	37.600		4	4	180					7.9	
300	102	NJP2328M		909.3	1229.8	2000	2400	6.760		4	4	180					9.2	
300	102	NU2328EM		1018.8	1384.5	1900	2200	37.600		4	4	180					7.9	
300	102	NJ2328M	HJ2328	909.3	1229.8	2000	2400	36.100	2.380	4	4	180		197.6	15	33.5	9.2	
300	102	NU2328M	HJ2328	909.3	1229.8	2000	2400	35.300	2.380	4	4	180		197.6	15	33.5	9.2	
360	82	NJ428X5M		952.8	1117.7	1600	1900	47.160		5	5	196						
150	270	45	NJP230EMA		440.2	581.3	2200	2700	12.520		4	4	182					2.4
	270	45	NJ230EMA		440.2	581.3	2200	2700	12.520		4	4	182					2.4
	270	45	NU230EMA		440.2	581.3	2200	2700	12.160		4	4	182					2.4
	270	45	NJ230EM		440.2	581.3	2200	2700	12.520		4	4	182					2.4
	270	45	NU230EM		440.2	581.3	2200	2700	12.000		4	4	182					2.4
	270	45	NUP230M		367.7	480.5	2200	2700	12.050		4	4	182					
	270	45	NJ230M		367.7	480.5	2200	2700	11.800		4	4	182					2.4
	270	45	NU230M		367.7	480.5	2200	2700	11.800		4	4	182					2.4
	320	65	NJ330EM		757.6	921.6	1800	2100	27.100		4	4	193					1.8
	320	65	NJ330M	HJ330	663.1	807.4	1900	2200	26.840	2.420	4	4	193		210	15	26.5	2.7
	320	65	NU330M	HJ330	663.1	807.4	1900	2200	26.280	2.420	4	4	193		210	15	26.5	2.7

¹⁾ Permissible axial displacement out of central position

E – bearings with higher load rating

M – two piece machined brass cage, roller centred

MA – two piece machined brass cage, outer ring centred

SINGLE-ROW CYLINDRICAL ROLLER BEARINGS

FOR LOCOMOTIVES

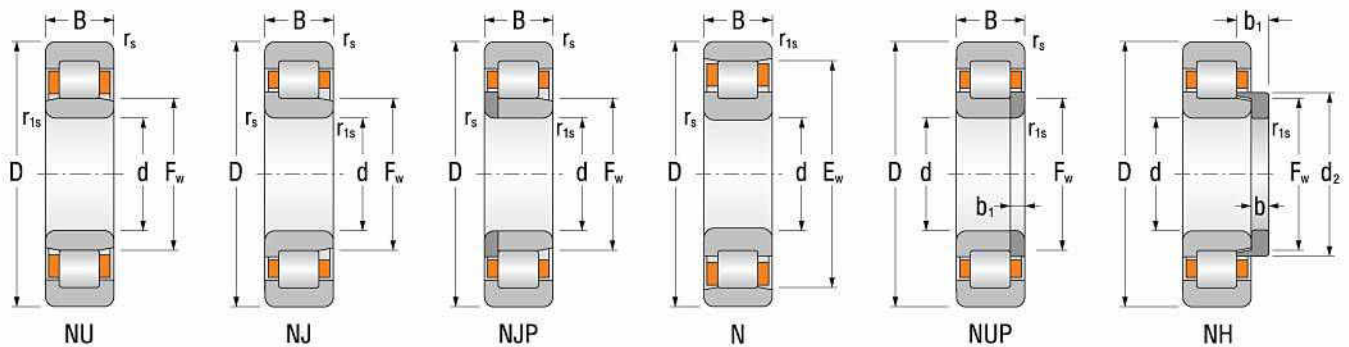

Dimensions			Bearings designation	Angle ring HJ	Basic load rating		Limiting speed for lubrication		Mass of		Dimensions						
d	D	B			dynamic C_r	static C_w	grease	oil	Bearing	Angle ring	$r_{s_{min}}$	$r_{1s_{min}}$	F_w	E_w	d_2	b	b_1
mm					kN		min^{-1}		kg		mm						
160	290	48	NJ232EM	HJ232E	498.6	666.4	2 000	2 400	14.70	1.520	4	4	195	206.2	12	20	2.5
	290	48	NJ232EM	HJ232E	498.6	666.4	2 000	2 400	14.70	1.520	4	4	195	206.2	12	20	2.5
	340	67	NJ332EM		857.8	1 053.2	1 700	2 000	32.20		4	4	195	204	12	20	2.5
170	310	52	NJ234EM		589.0	777.2	1 900	2 200	18.400		4	4	207				2.9
	310	52	NJ234EM	HJ234E	589.0	777.2	1 900	2 200	19.200	1.740	4	4	207	221.4	12	20	2.9
	310	52	NU234EM	HJ234E	589.0	777.2	1 900	2 200	16.600	1.740	4	4	207	221.4	12	20	2.9
180	280	46	NU1036M		334.6	474.52	100	2 500	9.858		2.1	2.1	205				3.6
	320	52	NJ236EM	HJ236E	611.3	826.0	1 800	2 100	19.500	1.820	4	4	217	230.5	12	20	2.9
	320	52	NU236EM	HJ236E	611.3	826.0	1 800	2 100	19.200	1.820	4	4	217	230.5	12	20	2.9
190	290	46	NJP1038EMA		411.2	612.0	1 970/2	360	12.100		2.1	2.1	214				2.5
	290	46	NU1038M		354.8	520.3	1 900	2 200	9.510		2.1	2.1	215				3.5
200	310	51	NUP1040M		381.9	567.1	1 900	2 200	14.750		2.1	2.1	229				4.2
	310	51	NJ1040M		381.9	567.1	1 900	2 200	14.000		2.1	2.1	229				4.2
	310	51	NU1040M		381.9	567.1	1 900	2 200	13.804		2.1	2.1	229				4.2
	360	58	NJ240EM	HJ240E	749.9	1 033.7	1 500	1 800	27.900	2.710	4	4	243	257.8	14	23	2.9
360	58	NU240EM	HJ240E	749.9	1 033.7	1 500	1 800	27.300	2.710	4	4	243	257.8	14	23	2.9	

¹⁾ Permissible axial displacement out of central position

E – bearings with higher load rating

M – two piece machined brass cage, roller centred

MA – two piece machined brass cage, outer ring centred



YOUR PARTNER FOR INDUSTRY



Contact
KINEX BEARINGS, a.s.
1. maja 71/36
014 83 Bytca
Slovakia



Technical support: servis.in@kinexbearings.sk

www.kinex.sk