



HANDBOOK

Our industrial products
and services at a glance



Dear **NTN** partner,

We have been working successfully for years to set up and improve our collaboration towards our common goal, satisfaction of the final customer.

As a leading manufacturer of rolling bearings and linear technology, we accompany our partners through challenges imposed by the market.

We are proud of the global offer made up of our brands **NTN** and **SNR**. We continuously improve our offer thanks to new products, responding to technical criteria for highly demanding applications, or economic criteria for very competitive markets and standard applications. We want to constantly satisfy our ever-changing market. Whatever the challenge, we generally have the solution.

This **NTN** manual has been created by **NTN** sales, marketing and engineering teams and integrates our partners' feedback. It is a practical approach to help you, as an **NTN** partner, to feel comfortable with our wide range of products and services.

This **NTN** manual focuses on what you really need in your day-to-day business. It is a silent companion which will give you quick help and many answers about our company and products.

In parallel, we hope that through our regular communication, you will have the full picture of who we are: our range, our expertise, and our proximity. You are our ambassadors, and you help convince the final customer. We count on you to convey our philosophy and spirit.

We look forward to your feedback on this manual at any time.

Yours sincerely,

Eric MALAVASI
VP of NTN-SNR ROULEMENTS
Responsible for Industrial Business Unit Europe and Africa region



Let's make the world move forward



We are **NTN** in EUROPE and we make the world **NAMERAKA**.
We are people at the service of movement.
We design & offer high added value mechanical products.
Our expertise makes us a reference.
We believe in a fluid, mobile & harmonious society.
We are driven by our willingness to cooperate.
We continuously build positive mobility.

○ SUMMARY

COMPANY 6

Our brands	9
Industry market offer for Europe	10

E-TOOLS 12

Digital flyers and catalogues	13
E-platform	14

BEARING TECHNOLOGY 16

Ball bearings 18

NTN - Deep groove ball bearings	20
SNR - Deep groove ball bearings	25
NTN - Angular contact ball bearings	30
NTN and SNR - Self-aligning ball bearings	32
NTN and SNR - Thrust ball bearings	33
NTN - High precision bearings	34
SNR - High precision bearings	37
Interchange table	38
Prefixes & suffixes	39

Cylindrical roller bearings 42

NTN - Single-row cylindrical roller bearings	44
NTN - Double-row cylindrical roller bearings	46
NTN - Four-row cylindrical roller bearings	46
Interchange table, prefixes & suffixes	47

Tapered roller bearings 48

NTN and SNR - Tapered roller bearings	50
Interchange tables, prefixes & suffixes	55

Spherical roller bearings 58

NTN and SNR - Spherical roller bearings	60
SNR - EF800 series for high-vibration applications	62
SNR - Sealed spherical roller bearings	63
SNR - Multi-market kits	64
SNR - KIZEI® Spherical roller bearings	66
NTN and SNR - Thrust spherical roller bearings	68
Interchange table, prefixes & suffixes	69

Needle roller bearings 70

NTN - Needle roller bearings	72
Interchange tables	74
Prefixes & suffixes	76

Solid lubrication 78

Bearing units 80

SNR - Bearing units with cast iron housings	82
SNR - Bearing units with pressed steel housings	84
SNR - Bearing units with stainless steel housings	85
SNR - Bearing units with thermoplastic housings	86
SNR - SENTINEL™ series	87
Sealing solutions	89
Combination overview	90
Protective caps & covers	92
Interchange tables	93

Split plummer block housings 98

SNR - SNCD housings	100
SNR - SNC / SNCD500	101
Multi-market kits	101

CMD customised modules 102

SNR - CMD customised modules	103
------------------------------	-----

LINEAR MOTION 104

Customised linear axes 106

SNR - Customised linear axes	108
------------------------------	-----

Standard linear axis 110

SNR - Standard linear axis	112
----------------------------	-----

Linear guides 114

SNR - Linear guides	116
---------------------	-----

Ball screws 118

SNR - Ball screws	120
-------------------	-----

Ball bushings 122

SNR - Ball bushings	124
---------------------	-----

TECHNICAL SERVICES 126

Maintenance tools 128

SNR - Induction heaters: SmartTemp	130
SNR - Hydraulic nuts	131
SNR - Other maintenance tools	131

Lubrication solutions 132

SNR - Single point lubricators	133
SNR - Multipoint lubrication solution	135
Lubrication range	135

Services 136

Training / e-learning	137
Technical support and commissioning maintenance	137
Bearing diagnosis	137
Advice on lubrication	137
Tool rental	137

Additional technical products 138

Constant velocity joints for industrial applications	139
--	-----

○ COMPANY

INNOVATION DRIVING YOUR PRODUCTION

Movement. It is constantly changing. It is analysed, brought under control, guided and mastered with the aim of deriving maximum benefit. It is more than merely a concept. It is the very essence of our commitment, namely designing and innovating to deliver the perfect solutions to the issues and constraints of today and tomorrow.

There are thousands of us around the world masterminding and developing solutions to raise the bar on your production performance. Our world-leading brands (**NTN**, **BCA**, **BOWER** and **SNR**) are marketed worldwide and deliver the best-fit solutions for working together and building a more environmentally-friendly society. Follow our lead and use interaction, anticipation and adaptation as the keys to guiding and shaping the future of the manufacturing, automotive and aviation markets.

€ 4.9 BILLION*
turnover

23,000*
employees

The local service of an international partner



118
Sales
offices

73
Production
sites

15
R&D
centres

*March 2022



DEDICATED TO SECTORS SUCH AS AGRICULTURE, PACKAGING, MINING, QUARRY, CEMENT, FOOD-PROCESSING, ENERGY, WATER, CONSTRUCTION MACHINERY, AUTOMOTIVE ETC.





Customer satisfaction is the key to success; it requires a daily commitment to contribute to performance objectives. That is why **NTN** offers innovative solutions and technical expertise to serve your business.

Our brands



With high-tech products resulting from advanced R&D and design, the **NTN** brand offers a wide range of solutions adapted to your most demanding technical requirement and high-end premium quality requirements.











Simply smart, **SNR** products have been designed to make their user's life easier. The range is made of a combination of indispensable premium quality products that answer your needs efficiently.



BCA & BOWER are both trademarks of **NTN** Corporation. These brands are mainly sold in the North American market.

Industry market offer for Europe

PRODUCT GROUP		BRAND	
		NTN®	SNR®
	BALL BEARING	✓	✓
	CYLINDRICAL ROLLER BEARING	✓	
	TAPERED ROLLER BEARING	✓	✓
	SPHERICAL ROLLER BEARING*	✓	✓
	NEEDLE ROLLER BEARING	✓	
	BEARING UNIT**	✓	✓
	SPLIT PLUMMER BLOCK HOUSING***	✓	✓
	LINEAR MOTION		✓
	SERVICES		✓

* A part of the range of **SNR** spherical roller bearings is currently being converted to the **NTN** brand.

NTN spherical roller bearings are, like the **SNR** products, mainly in the E design with optimised performance.

** In Europe, we propose mainly the **SNR** bearing unit range which is available from stock both in European and Asian designs.

***In Europe, we propose mainly the **SNR** split plummer block housing.

ZOOM ON SOME TECHNICAL PRODUCTS: THE CUSTOMISED MODULES



Customer-specific,
ready to install mounted units

The european **NTN** team will
develop, together with you,
individual mounted
units according to
your requirements

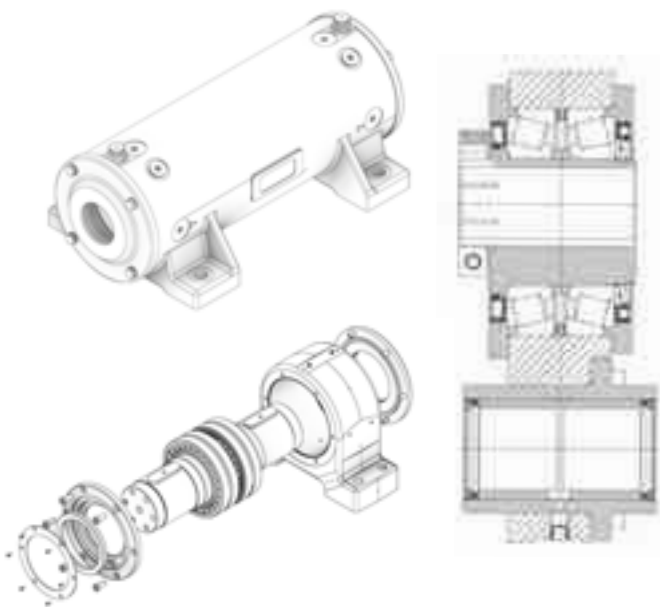

◀ Enquiry form available at the end
of the dedicated brochure

Questions?... cmd@ntn-snr.de

You can find more information in page 106 of this
handbook and on our dedicated brochure



**NTN,
YOUR
ENGINEERING
PARTNER**



○ E-TOOLS

Digital flyers and catalogues

ACCESS TO OUR WEBSITE: www.ntn-snr.com

Information about our products and services

Download catalogues and flyers in the menu "OnlineTools" > "Documentation"

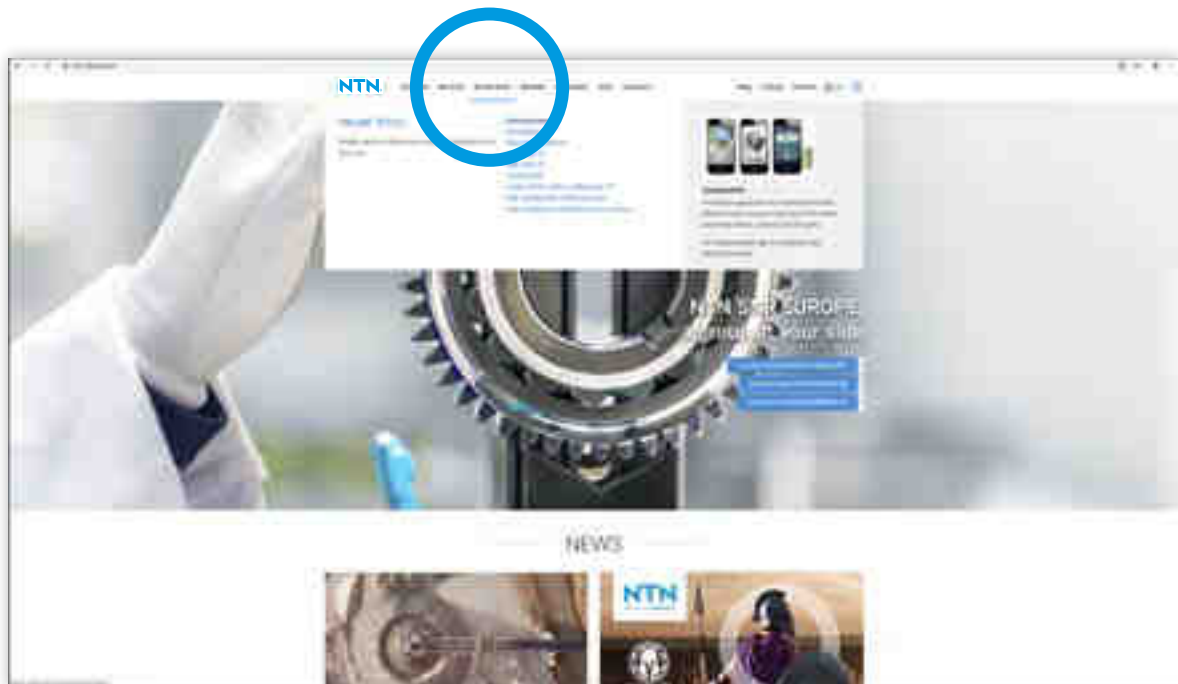

E-platform

ACCESS TO OUR E-SHOP: www.eshop.ntn-snr.com

Convert products to NTN and/or SNR

Type a competition reference in the research bar

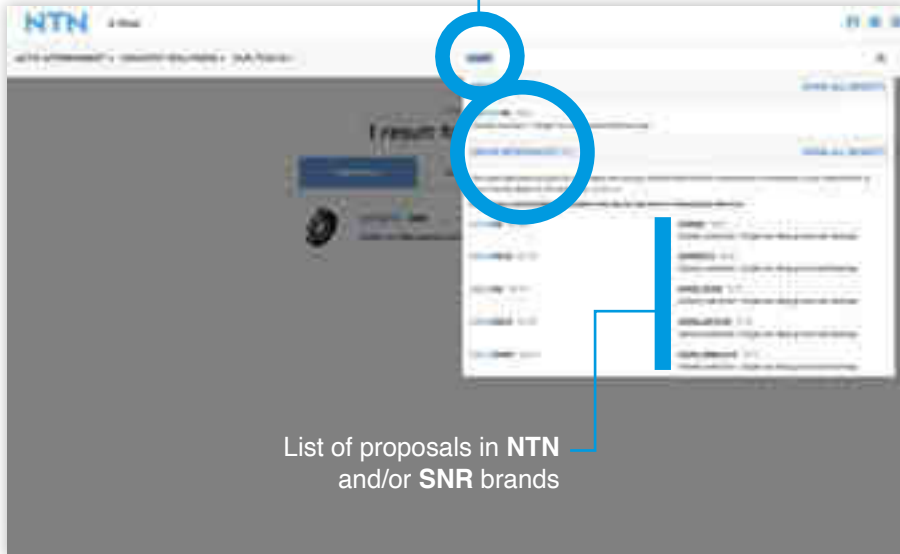

List of proposals in NTN and/or SNR brands

TIP
If an article is not found, you should vary slightly with the input of the suffix.
Example: 62052RSR
= 6205 2RSR
= 6205-2RSR
....

Prefix and suffix (tabular)

An extensive overview can be found in the e-shop (even without being logged in) on the right of the website in the "Our tools" menu → "Prefixes and suffixes signification". It is important to first select the right tab "Prefix or Suffix".

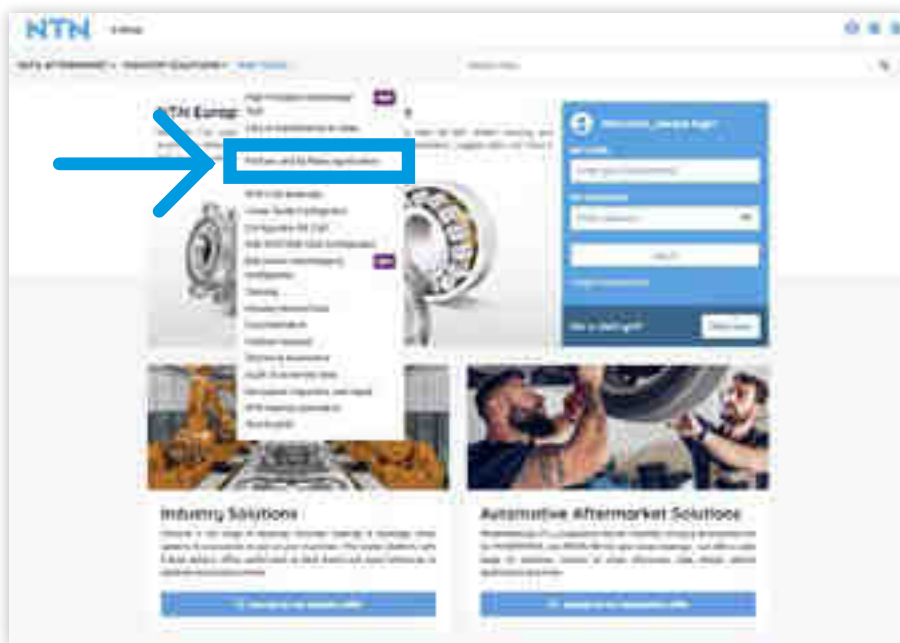

Note: More detailed conversion tables for our self-aligning bearing units and needle bearing ranges are also available as a separate document or desk pad. Don't hesitate to contact us.

Orders and access to information

When you are logged in, you have many options, such as configuring goods from our company or viewing order and delivery documents afterwards.

If you haven't already done so, simply apply for online access to our e-shop. Please do not hesitate to speak to your contact person in sales.

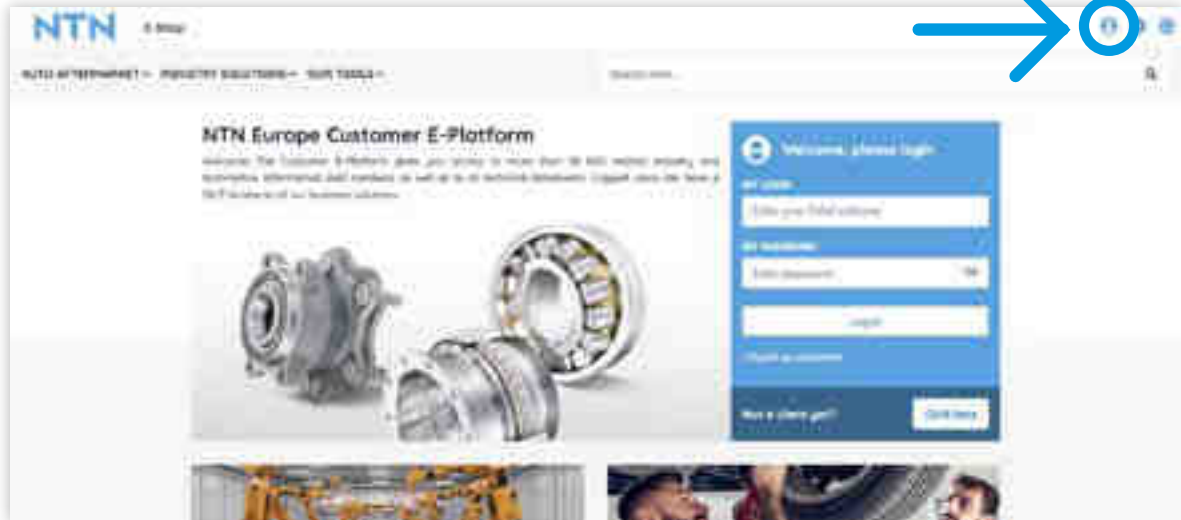

In the task bar at the top right of the e-shop you will find the corresponding menu items to make specific entries or to request information. On the right, for example, you will find the overview menu, which gives you access to all information regarding your offers, orders or deliveries. You can also configure your desired views under "Settings".

Shopping cart

Here you will find all information about your selected types once again bundled. You can also import and export complete lists.

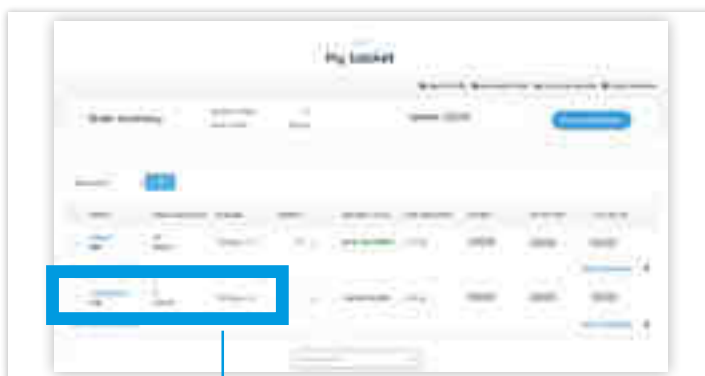

TIP

By clicking on "Industry Alternative", you will be able to identify alternatives to requested product, with information on price and availability!

○ BEARING TECHNOLOGY





BALL BEARINGS

Deep groove ball bearings enjoy the silence



NTN has enhanced the quality of its offer in the field of deep-groove ball bearings. CM internal clearance, with reduced tolerance, is now the new standard for the **NTN** brand. This upgrade is proof that **NTN** is determined to make the very best of Japanese technology available to you.

The comfort of reduced noise levels is now within your reach!

NTN

NTN - Deep groove ball bearings

Deep groove ball bearings are very common. The inner and outer rings have deep raceways, enabling them to support radial and axial loads in both directions, as well as combined loads resulting from the combination of all forces. Deep groove ball bearings are also suitable for high-speed applications.

NTN
The highly technical brand



The NTN brand offers you a wide range of deep groove ball bearings combining the best solutions for sealing, radial clearance and lubrication for an optimum response to the requirements of your activity.

Technical features

- High-end premium quality
- Very wide range with a strong sealing offer (see next page)
- CM tolerances as standard (normal internal clearance) at no extra charge
- Standard grease "5K" (Multemp SRL) suitable for temperatures from -40°C up to 150°C
- Suitable solutions for almost all applications

A WIDE RANGE OF DEEP GROOVE BALL BEARINGS OFFERING THE BEST PERFORMANCES IN THE MARKET

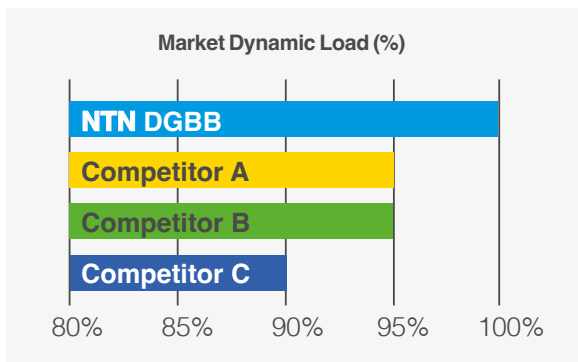

NTN bearings ensure **optimum performance and service life.**

Study carried out in 2021, based on the 3 main European market player catalogues

GOOD TO KNOW!

5K lubrication benefits from an eco-label in its country of origin (Japan) and is more than 60% biodegradable (28 days).

Standard cage type and range overview

Cage design	Series							
	60XX	62XX	63XX	64XX	68XX	69XX	67XX	160XX
Pressed steel cage	6000	6200	6300	6403	6800	6900	6700	16001
	~ 6052	~ 6244	~ 6344	~ 6416	~ 6834	~ 6934	~ 6706	~ 16052
Machined cage	6056	-	-	-	6836	6936	-	16052
	~ 6084	-	-	-	~ 68-600	~ 69-500	-	~ 16072

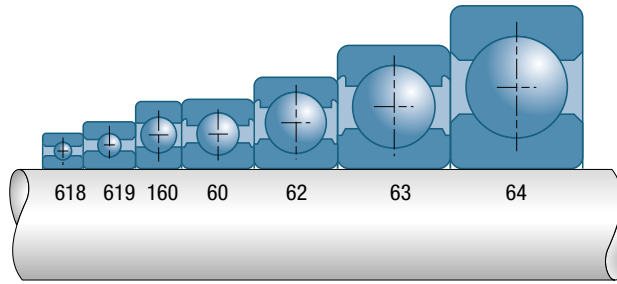

Note:
618XX = NTN 68XX
619XX = NTN 69XX

Sealing concept

Basic concept

All deep groove ball bearings, irrespective of size, are manufactured with a "V"-shaped groove in the inner ring, which, depending on the design, acts as a labyrinth seal in conjunction with the seal.

During the operating cycle of the bearing, the reduction of interference from the inner lip gradually brings the outer lip into contact with the inner ring.

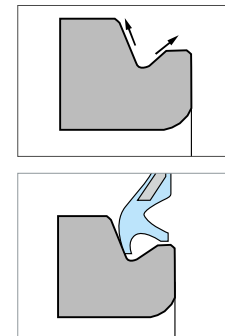

Benefits

- Particles are kept away or evacuated
- Grease is pressed inwards
- High performance for long-lasting protection

Overview of NTN standard seals

Types and codes		Shielded type		Sealed type	
		Non-contact type ZZ	Non-contact type LLB	Contact type LLU	Low torque type LLH
Construction					
		Metal shield plate is fixed to the outside ring; the inner ring incorporates a V-groove and labyrinth clearance.	The outer ring incorporates synthetic rubber molded to a steel plate; seal edge is aligned with V-groove along inner ring surface with labyrinth clearance.	The outer ring incorporates synthetic rubber molded to a steel plate; seal edge contacts V-groove along inner ring surface.	Basic construction is the same as LLU type, but a specially designed lip on the edge of the seal prevents foreign matter penetration; low torque construction.
Performance comparison	Torque	Small	Small	Higher	Medium
	Dust proofing	Good	Better than ZZ-type	Excellent	Much better than LLB-type
	Water proofing	Poor	Poor	Very good	Good
	High speed capacity	Same as open type	Same as open type	Limited by contact seals	Much better than LLU-type
	Allowable temp. range ⁽¹⁾	Depends on lubricant	-25 to 120°C	-25 to 110°C	-25 to 120°C

1) Please consult NTN Engineering about applications which exceed the allowable temperature range of products listed on this table. Note: This chart lists double shielded and double sealed bearings, but single shielded (Z) and single sealed (LB, LU, LH) are also available. Grease lubrication should be used with single shielded and single sealed bearings.

For more information, check online **NTN Ball & Roller Bearings catalogue** on www.ntn-snr.com/documents

CM tolerance for low-noise performance

- Standard: reduced bearing clearance tolerances reduce vibrations and decrease the noise level
- CM radial clearance available for entire **NTN** standard 6xxx deep groove ball bearing range
- Available for open, shielded and sealed versions (-ZZ, -LLU and -LLB)

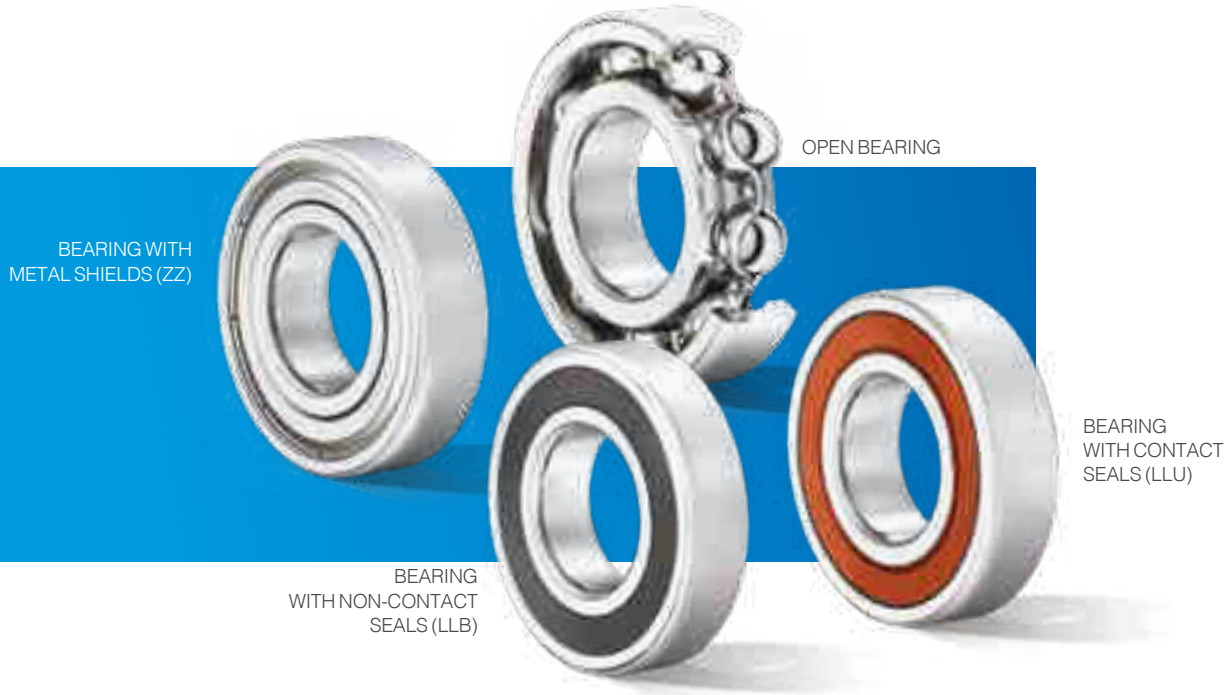

Designations

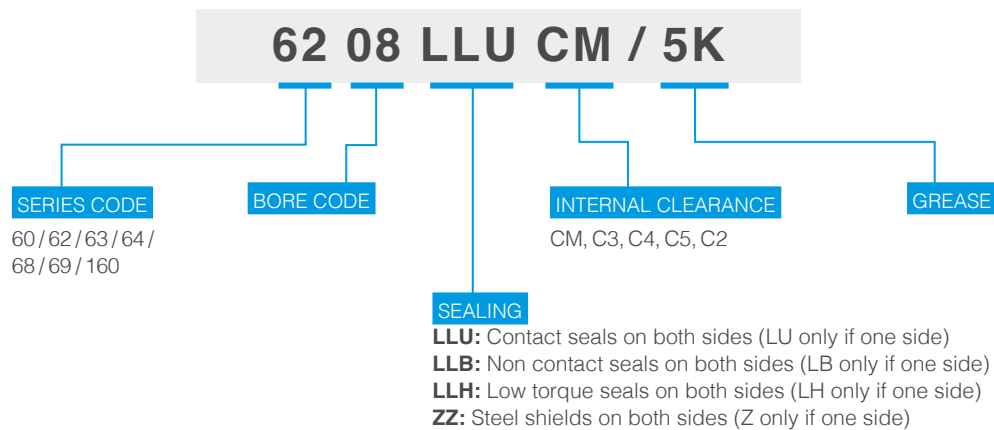

More info about prefix, suffix & interchange table? Check from page 42

Focus on NTN electrically insulated bearings: MEGAOHM™

Technical features

- Withstanding up to 3 000 VDC as standard
- Ceramic layer on outer ring
- In accordance with standards ISO 492, DIN 620 and JIS 1514

Range overview

- Massive brass cage available from stock (L1B Suffix)
- Steel cage on request
- C3 internal clearance as standard available from stock
- C4 internal clearance on request

Benefits

- Avoid premature damage due to current leakage
- Strength thanks to the brass cage
- Ensured interchangeability



Series	Bore diameter code													
	10	12	14	15	16	17	18	19	20	22	24	26	28	30
7MC3-62XXL1BC3														
7MC3-63XXL1BC3														
7MC3-63XXL1BC4														

For more information, check online brochures www.ntn-snr.com/documents/megaohm

SENTINEL™ series

NTN stainless steel deep groove ball bearing with spot-pack solid grease (LP09) as lubricant is the best opportunity to mix security for food/beverage industries and sustainability for the production equipment.



Technical features

- 440C stainless steel bearing, 304 stainless steel cage
- Specific nitrile seal reinforced
- **NTN** spot-pack solid grease (LP09), NSF approval / H1 category code
- Operating temperature: from -10°C to +80°C (100°C peak)

Benefits

- 440C material is the best compromise between load rating capacity and corrosion resistance
- Solid grease reduced lubricant leakage even when bearing is subjected to high vibration and centrifugal force
- Compare with general-purpose food grease lubricant, solid grease is less prone to emulsification and leakage due to water penetration
- Solid grease with spot-pack application offer a good level of speed rotation while maintaining solid lubricant advantages

Range overview

Code bore P/Ns

- From 000 to 008 (6000 to 6008)
- From 200 to 208 (6200 to 6208)

Designations

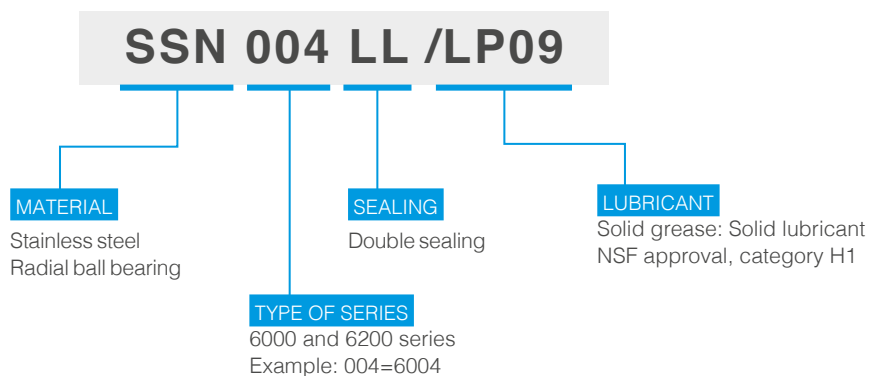

SNR - Deep groove ball bearings



The simply smart brand

NTN proposes the **SNR** simply smart range of deep groove ball bearings. It is a compact range that contains the indispensable sizes and offers standard sealing options with premium brand quality.

Technical features

- Normal internal clearance and C3
- **SNR** deep groove ball bearings are designed with a steel cage as standard - options on request
- Sealed versions are already greased. The maximum operating temperature is +120°C
- Suitable solutions for almost all applications



Range overview

Series	60X	62X	63X	60XX	62XX	63XX
Dim.	607	623	634	6000	6200	6300
	~ 609	~ 629	~ 635	~ 6028	~ 6226	~ 6322
INTERNAL CLEARANCE: normal, C3						
OPEN / SHIELDED -ZZ / SEALED -EE						

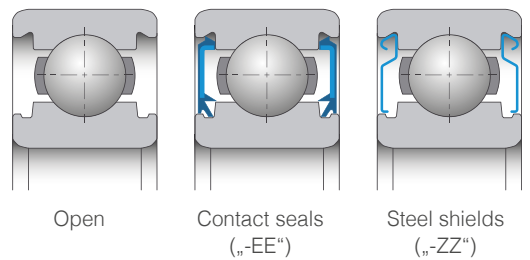

More info about prefix, suffix and Interchange table
Check from page 42

A range with continuous technical improvement to meet the needs of your application

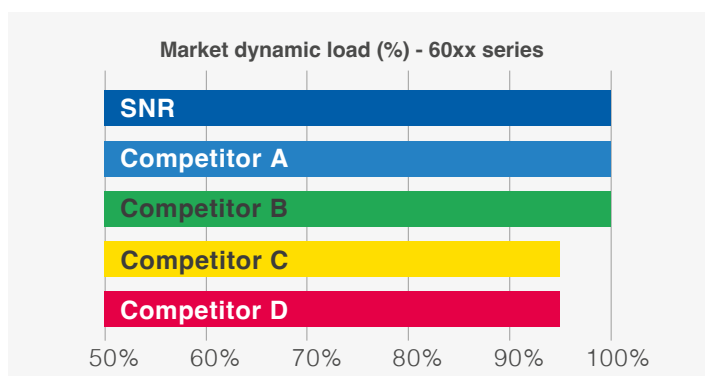

Study carried out in 2022, based on the main European market player catalogues

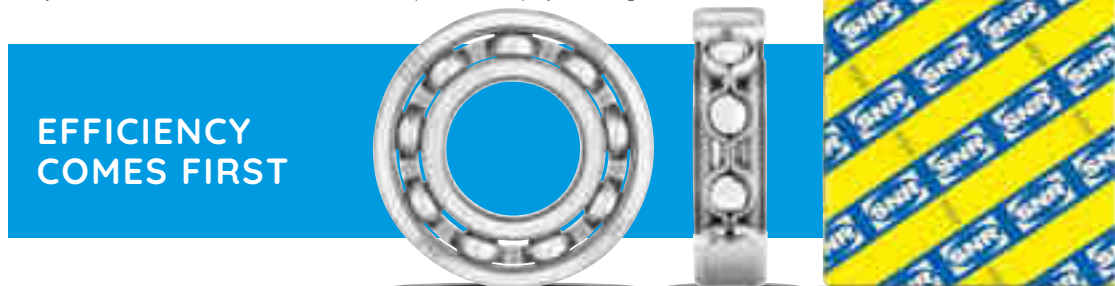



Double-row deep groove ball bearings

Double row deep groove ball bearings are designed to accept higher loads than a single row ball bearing.

They have identical outside diameters and bores but are slightly wider, thus having a much higher load capacity.

Technical features

- Polyamide cage as standard (no suffix)
- Without filling slot (suffix A)
- Normal internal clearance
- Open type

Range overview

	Bore diameter code										
Serie	00	01	02	03	04	05	06	07	08	09	10
42xxA											



Easy to work

Premium quality

Competitiveness booster

EMTR

Focus on our ball bearing range dedicated to electric motors

- Deep groove ball bearings of series 6000, 6200 and 6300
- For applications with specific temperatures or speed requirements

Are you looking for higher reliability and quality, with the lowest noise level, without compromising on price?

The new EMTR bearing range with optimised design for electric motors brings you the solution.

Technical features

- C3 internal clearance
 - Special low noise grease
 - Up to 150°C usage: no suffix in the designation
 - High temperature usage (up to 200°C): D189 suffix
 - Precision Class P6 (ISO 492) and improved grade for balls (G10) with special vibration check
 - Benefit:
 - Raceway roughness: improved by 25%*
 - Raceway roundness: improved by 20%*
- * Compared to **SNR's** standard tolerance



Benefits

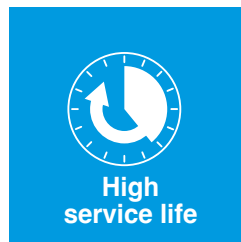
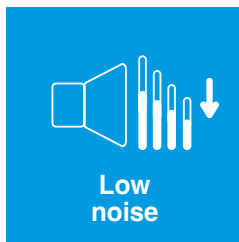

Range overview

6201 >> 6206 + 6304

Designations

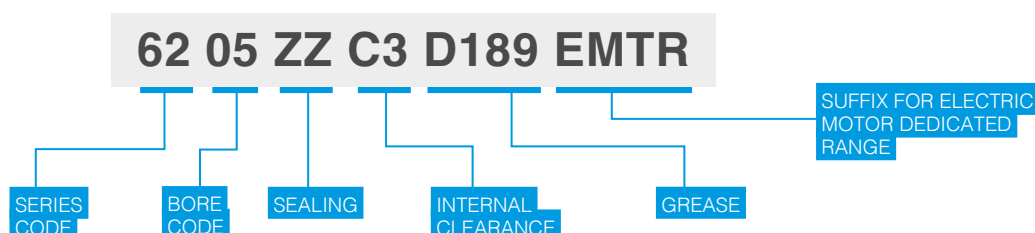

The unique range of ball bearings dedicated to extreme applications.

Deep groove ball bearings of series 6000, 6200 and 6300.

For applications with specific temperatures or speed requirements.

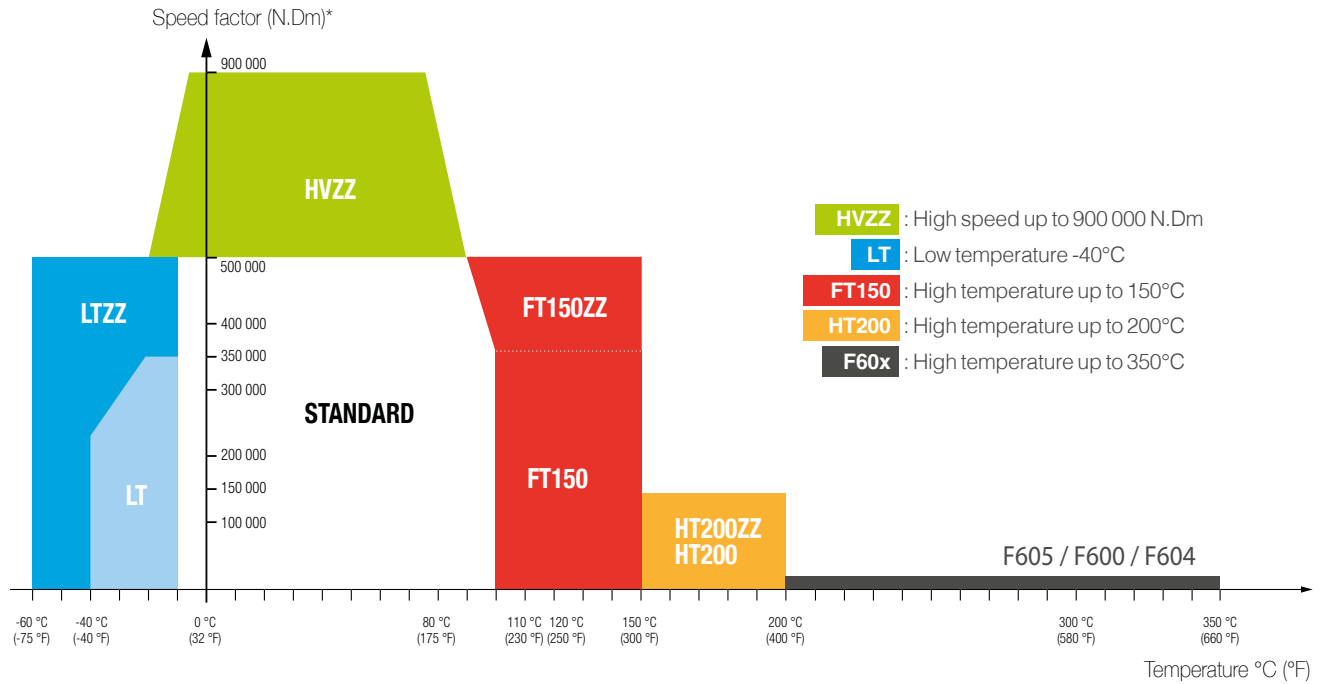

- High availability to solve problems quickly
- A unique product range from a premium brand
- A ready to use range for specific applications
- Wide selection of bore diameters for the 6000, 6200 and 6300 series
- Technically optimised products: cage, internal clearance, lubricant and seals
- The technical support from our teams

“A bearing for each specific use”



* N.Dm is a speed factor where N is the speed of rotation in rpm and Dm is the average diameter of the bearing $(d + D)/2$



TOPLINE
The unique range of ball bearings dedicated to extreme applications



Products	Cage	Internal clearance	Grease	Sealing	Other	Temperature range
HVZZ	Glass fibre reinforced polyamide 6.6	C3	Superior quality. Lithium thickener + synthetic base oil	Steel shields	Precision P6, P5. High-precision balls (<= Class 10)	-20°C to +120°C
LT LTZZ	Steel	C3	Suited to low temperatures. Lithium thickener + synthetic base oil	Nitrile rubber seals (NBR) or steel shields	-	LT: -40°C to +100°C LTZZ: -60°C to +120°C
FT150 FT150ZZ	Steel	C3	Adapted to high temperatures. Polyurea thickener + synthetic base oil	Fluoroelastomer seals (FKM) or steel shields	-	-30°C to +150°C
HT200 HT200ZZ	Steel	C4	Adapted to high temperatures. PTFE solid lubricant and PFPE oil	Fluoroelastomer seals (FKM) or steel shields	Specific heat treatment	-40°C to +200°C
F605	Steel	Multiple of C5*	**	-	Brand is stamped	Temperature range between +200°C and +350°C (continuous or cyclic)
F600	Steel	Multiple of C5*		-	Specific surface treatment (phosphatisation + MoS2 deposition)***	
F604	Steel	Multiple of C5*		Suitable for very high temperatures. Polyalkylene glycol base oil + solid additive	Steel shields	



* Significantly increased internal clearance to offset the material's expansion effects.

** In case of F600 and F605, if additional lubrication is required, an appropriate amount of grease may be introduced into the bearing. Contact **NTN** for more information.

*** Surface treatment for greater oxidation resistance and improved lubrication. Caution: F600 and F604 products must be used with care in damp environments, since MoS2 may react with water to produce sulphuric acid.



NTN - Angular contact ball bearings

NTN

NTN - Single row angular contact ball bearings

The single row angular contact ball bearing is designed to withstand combined loads with a predominant axial component. Installed in opposition with another bearing of the same type, it guarantees high mounting rigidity.

A wide range for standard industry applications.

Technical features

- Contact angle 30° (without suffix) or angle 40° (B suffix)
- Pressed steel cage (without suffix) or massive brass cage (L1)
- Single row series: 7000, 7200, 7300
- Universal pairing available (G suffix: Flush ground*)
- Clearance as standard
- Preload on demand



NTN

NTN - Four point contact bearings (QJ-bearings)

Four-point contact ball bearings are single row radial angular contact ball bearings with raceways designed to withstand axial loads in both directions.

Technical features

- Standard contact angle: 30°
- Massive steel cage as standard
- Split inner ring
- Available series: QJ2xx and QJ3xx



More info about prefix, suffix & interchange table check from page 42

* "Flush ground" is the name given to the finishing method where the offset of the front and back faces of the bearing are ground to the same value. This allows a designated clearance or preload value to be achieved when using bearings with identical codes in DB or DF orientations. DT series bearings can also be used in various arrangements to achieve uniform load distribution.

NTN and SNR - Double-row angular contact ball bearings

NTN

SNR

Double-row angular contact ball bearings have a similar configuration as two angular contact ball bearings but have the advantage of a smaller space requirement. These bearings support axial and radial loads in both directions.

NTN and SNR: two brands to offer you a full range of possibilities.



Technical features

- Two cage variants: pressed steel (suffix S in **NTN**) or polyamide (suffix A or G15 in **SNR**)
- Open or sealed with steel shields (-ZZ) or seals (-LL in **NTN** or -EE in **SNR**)
- Careful:
 - Contact angle 25° without filling slot ► **NTN** or **SNR**
 - Contact angle 32° with filling slot ► only **NTN**

Standard cage type and range overview

SUFFIXES FOR OPEN SERIES

SERIE	NTN	SNR	TYPE
3XXX	S	-	32° contact angle with filling slot Pressed steel cage Ungreased
	-	A	25° contact angle without filling slot Polyamide cage Greased
5XXX	S	-	25° contact angle without filling slot Pressed steel cage Ungreased

SUFFIXES FOR SEALED SERIES WITH SHIELDS

SERIE	NTN	SNR	TYPE
5xxx	SCZZ	-	25° contact angle without filling slot Pressed steel cage Greased
	-	ZZG15	25° contact angle without filling slot Polyamide cage Greased

SUFFIXES FOR SEALED SERIES WITH SEALS

SERIE	NTN	SNR	TYPE
5xxx	SCLLD	-	25° contact angle without filling slot Pressed steel cage Greased
	-	EEG15	25° contact angle without filling slot Polyamide cage Greased

Note:
Be careful with cross references on this product type.
Some important discrepancies exist on series number.
Example:
FAG 3201-B-2RS-TVH corresponds to **SNR** 5201EEG15

In **NTN** and **SNR** ranges:
3XXX row is open (note contact angle if necessary)
5XXX is usually sealed (-ZZ or -EE / -LL)

NTN and SNR - Self-aligning ball bearings

Self-aligning ball bearings have two rows of balls, their outer ring raceway forms a spherical surface and their inner ring has two raceways. The balls, cage and inner ring of these bearings are capable of shifting to compensate for a certain degree of misalignment with the outer ring. Consequently, these bearings are able to align themselves and compensate for shaft / housing finishing unevenness, bearing fitting error and other sources of misalignment. These bearings are designed to support radial loads and are not suitable for applications with heavy axial loads.

Technical features

- Contact angle bearing
- Steel cage (**NTN**) or polyamide cage (**SNR** – G14 / G15 suffix)
- Clearance: normal, C3, C4
- Cylindrical or tapered bore
- Sealed products available in **SNR** brand for 22xx & 23xx series (-EE suffix)
- Wider inner ring range available in **SNR** brand (112xx & 113xx series)



Standard cage type and range overview

NTN	Series			
	12xx	13xx	22xx	23xx
Cylindrical bore	1200S	1300S	2200S	2300S
	~ 1222S	~ 1322S	~ 2222S	~ 2322S
Tapered bore	1204SK	1304SK	2204SK	2304SK
	~ 1222SK	~ 1322SK	~ 2222SK	~ 2322SK
Cage material	Pressed steel cage		Pressed steel cage Machined cage: 2321S, 2322S	
INTERNAL CLEARANCE: normal, C3				

SNR	Series					
	12xx	13xx	22xx	23xx	112xx	113xx
Cylindrical bore	1201	1302	2201	2302	11204	11305
	~ 1222	~ 1320	~ 2220	~ 2318	~ 11212	~ 11310
Tapered bore	1205K	1305K	2204K	2305K	-	-
	~ 1222K	~ 1317K	~ 2220K	~ 2315K		
Cage material	Pressed steel or Polyamide (G15)		Pressed steel or Polyamide (G15/G14)		Polyamide (G15)	Polyamide (G15)
Sealing			2201 ~ 2212 EE with polyamide cage	2303 ~ 2310 EE with polyamide cage		
INTERNAL CLEARANCE: normal, C3, C4						

NTN and SNR - Thrust ball bearings

NTN

SNR

Thrust ball bearings are designed to support axial loads. Single direction thrust ball bearings support the axial load of a shaft in only one direction.

Technical features

Thrust ball bearings consist of separable elements:

- Shaft locating washer
- Housing plate
- Ball-ring

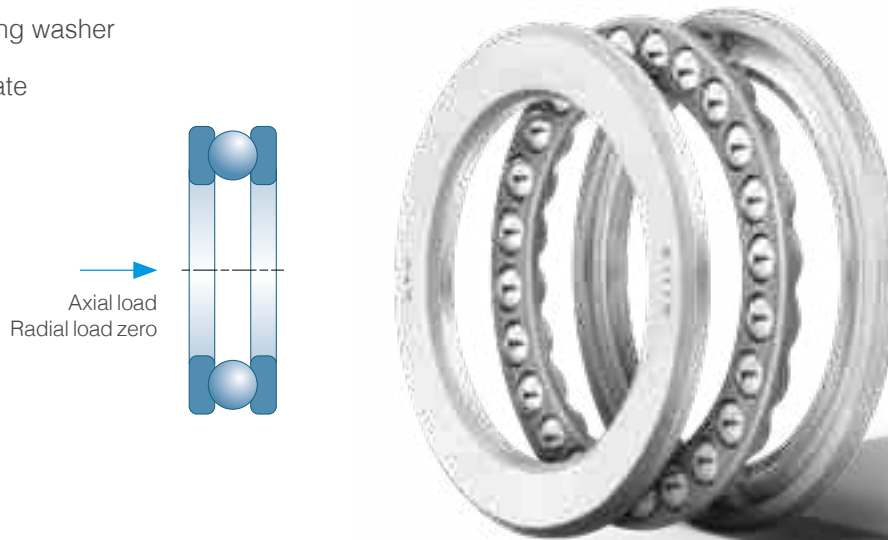

Standard cage type and range overview

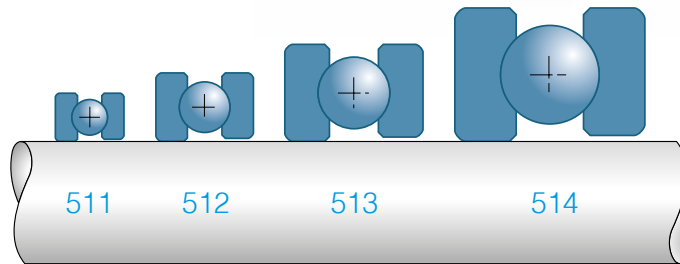

NTN	Series			
	511	512	513	514
Polyamide cage	51100	51200	-	-
	~ 51107	~ 51207	-	-
Pressed steel cage	51108	51208	51305	51405
	~ 51152	~ 51224	~ 51320	~ 51415
Solid brass cage	51156	51226	51322	51416
	~ 511/530	~ 51260	~ 51340	~ 51420

SNR	Series			
	511	512	513	514
Polyamide cage	-	-	-	-
	-	-	-	-
Pressed steel cage	51100	51202	51305	51405
	~ 51132	~ 51217	~ 51313	~ 51415
Solid brass cage	-	-	-	-
	-	-	-	-

NTN - High precision bearings

Precision rolling bearings, which are generally also referred to as spindle bearings, are primarily used in machine tools. Generally, the optimal bearing must be selected to suit the nature of the machine, the area within the machine, the spindle specification, bearing type, lubrication system and drive system of the intended machine through considerations of the design life, precision, rigidity and critical speed of the bearing.



Offer

- Standard, open
- Standard, sealed
- High-speed, open
- High-speed, sealed
- All bearings are also available with ceramic balls ("5S")

ULTAGE™ performance

Stock of pairable universal bearing called 'Flush ground' bearings ("G") with normal preload ("GN").
Sets and bearings with restricted tolerances can be offered individually (O-, X-, tandem etc.).

ULTAGE™

Designations

5S- 70 08 UC T1A LLB G / GL P42 / L749

BALL MATERIAL	
5S-	Ceramic balls
-	Steel balls

ULTAGE™
(will not be used for sealed bearings)

DIMENSION SERIES	
70, 79	

CONTACT ANGLE	
Code	Angle
C	15° (Open)
CD	15° (Sealed)
AD	25°
-	30° (Open)

BEARING ARRANGEMENT	
G	Single universal bearing 'Flush ground'
GD2	Duplex universal bearing
GD3	Triplex universal bearing
GD4	Quadruplex universal bearing
DB	O-Arrangement < >
DBT	Tandem-O-Arrangement << >
DTBT	Tandem-O-Tandem-Arrangement << >>

ACCURACY	
P5	ISO Class 5
P4	ISO Class 4
P42	Dimensional accuracy ISO Class 4, Running accuracy Class 2
P2	ISO Class 2
UP-xx	Special accuracy

BORE CODE	
Bore	Dimension
00	10 mm
01	12 mm
02	15 mm
03	17 mm
04*5	20 mm
05*5	25 mm
...*5	etc

CAGE	
-	Polyamide cage, ball guided
T1A	Phenolic cage, outer ring guided
T1B	Phenolic cage, ball guides

SEAL	
LLB	Non contact seals

PRELOAD	
GL	Light preload
GN	Normal preload
GM	Medium preload
GH	High preload
Gxx	Special preload
Csxx	Special clearance

GREASE	
-	Without grease filling
L749	SE-1 Grease
L448	MP-1
15K	NBU 15
Lxx	Please get in contact with NTN engineering

You can find more information in our catalogue or on demand.

Table for translation

		NTN	SNR	FAG	NSK	SKF
Bearing series (sorted by size)		78		B718	78	718
		79U	719	B719	79	719
		70U	70	B70	70	70
		72	72	B72	72	72
Contact angle		15° (-C) 25° (-AD) 30° ("'-")	15° (-C) 25° (-H) -	15° (-C) 25° (-E) -	15° (-C) 25° (-A5) 30° (-A)	15° (-CD) 25° (-ACD) -
Cage	Polyamide (Ball guided)	No suffix	-	-	-TYN	-
	Phenolic resin cage (Outer ring guided)	-T1A	V (Serie 719-70) G1 (Serie 72)	-T	-TR	No suffix
Universal bearing 'Flush ground' (pairable)		-G	-U	-U	-SU	-G
Preload	Light	-GL	-	-	-EL	-
	Normal	-GN	7	-L	-L	-GA
	Medium	-GM	8	-M	-M	-GB
	High	-GH	9	-H	-H	-GC
Precision (Standard)		P42	4 4S (Serie ML-MLE)	P4S	P3	P4A

The interchanges are given for information only and you should check that the chosen product corresponds to your requirements. In case of doubt, please do not hesitate to contact us.



Universal matching of NTN high precision bearings

Angular contact ball bearings are often combined in different arrangements for special purposes. Thanks to the flush grinding technique, the face height difference between the inner and outer rings is equal on both faces of a universal bearing (G suffix). Thus, you can assemble various bearing arrangements and achieve the specified preload:

1 Bore and outer diameter deviation shown on the boxes label:

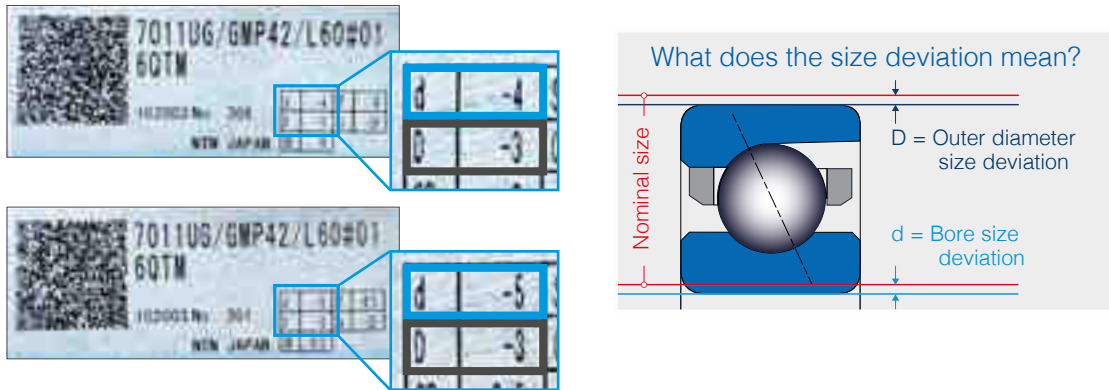

2 Δd and ΔD permissible values for matched bearings set:

7000 series*	Maximum permissible Δd in μm	Maximum permissible ΔD in μm	7900 series*	Maximum permissible Δd in μm	Maximum permissible ΔD in μm
7000 ▶ 7015	2	2	7900 ▶ 7917	2	2
7016 ▶ 7024	2	3	7918 ▶ 7924	2	3
7025 ▶ 7026	3	3	7925 ▶ 7926	3	3

*For P4, P42 precision

3 Determination of Δd and ΔD :

Δd = bore size difference in a matched set (μm) = $|d_1 - d_2|$
 ΔD = OD size difference in a matched set (μm) = $|D_1 - D_2|$

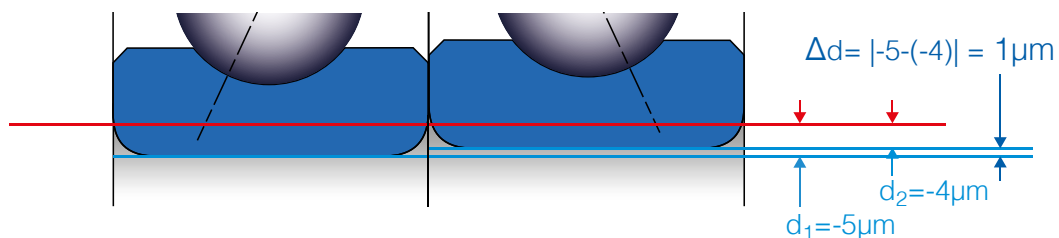

4 Example of duplex arrangement:

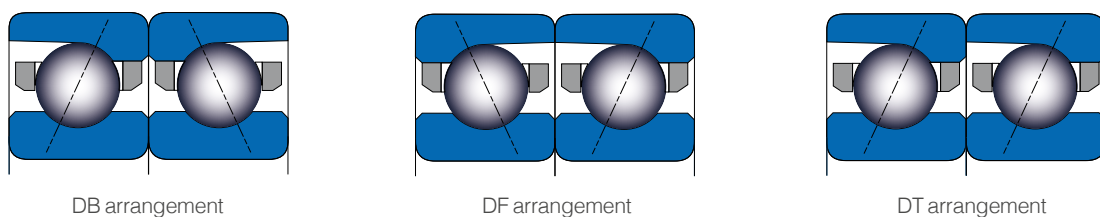

SNR - High precision bearings



Machline is a complete line of precision bearings. It combines high rotation speed and increased load capacity to meet the ever-increasing requirements of your machines.

The ML and CH ranges have been specially designed to withstand very high rotation speeds.

The sealed MLE range has lifetime lubrication and thus eliminates periodic greasing.

All Machline spindle bearings are produced to the P4S precision specification, which incorporates ISO 4 (ABEC 7) dimensional tolerances and ISO 2 (ABEC 9) dynamic tolerances.

Offer

- Machline high precision: standard
- Machline ML: high Speed
- Machline MLE: sealed
- Machline CH: hybrid (available in all ranges)

All Machline bearings are available in the universal version (U), as a universal bearing set (DU, TU) and a matched bearing set (DB, DF, DT...).



machline

Designations

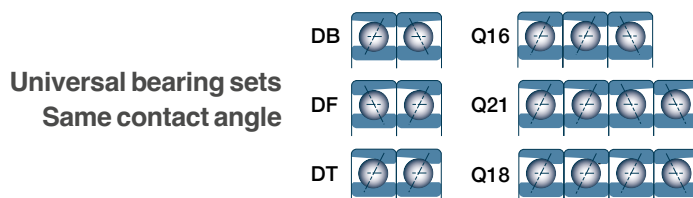
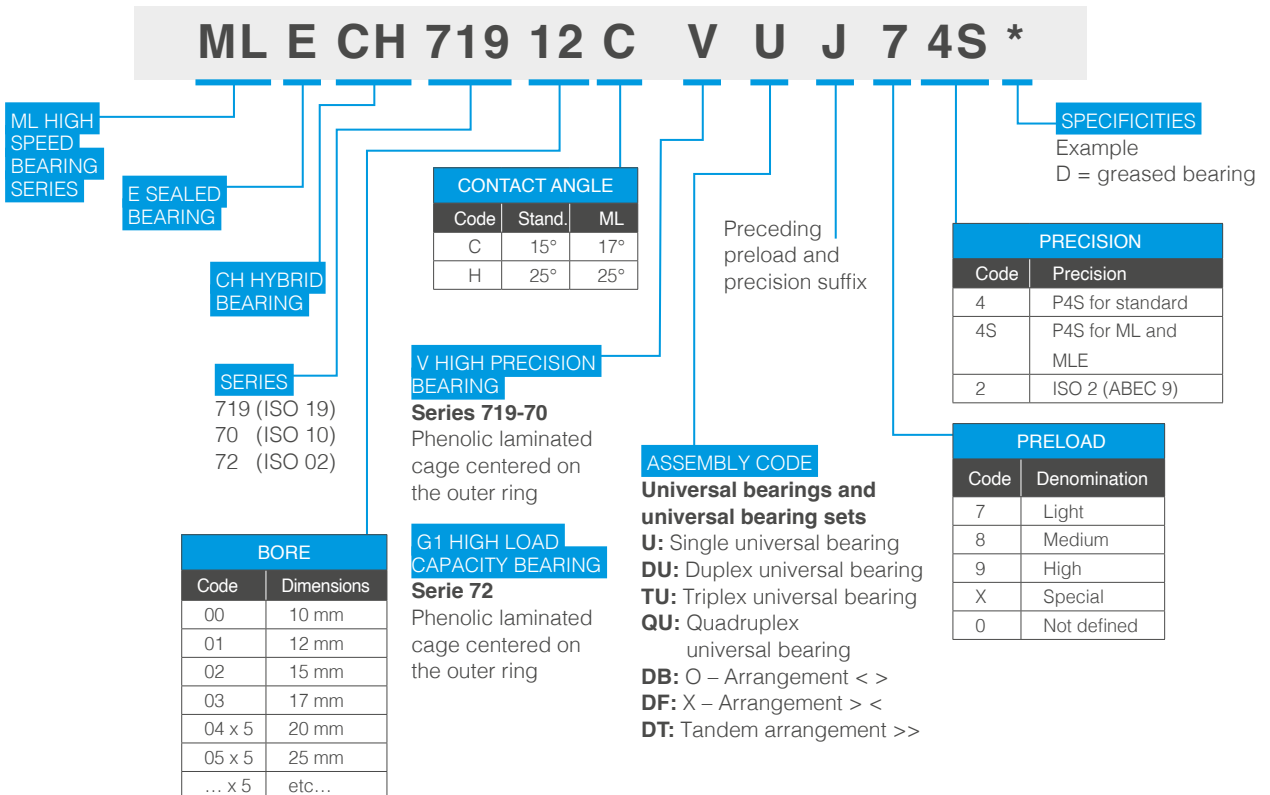

Interchange table

	TYPE OF BEARING	TECHNICAL SPECIFICATION	NTN	SNR	FAG	SKF	NSK
DEEP GROOVE BALL BEARINGS	600 6700 6800 (61800) 6900 (61900) 6000 / 6200 6300 / 6400 16000 / 16100	1 or 2 pressed steel shields	Z / ZZ	Z / ZZ	Z / ZZ	Z / ZZ	Z / ZZ
		1 or 2 contact seals	LU / LLU	E / EE	HRS / 2HRS	RS1 / 2RS1	DU / DDU
		1 or 2 non contact seals	LB / LLB	-	RSR / 2RSR BRS / 2BRS	RZ / 2RZ	V / VV
		Groove without/with retaining ring	N / NR	N / NR	N / NR	N / NR	N / NR
		Internal clearance (if diff. from normal radial clearance)	C2 / C3 etc.	C2 / C3 etc.	C2 / C3 etc.	C2 / C3 etc.	C2 / C3 etc.
DOUBLE ROW DEEP GROOVE BALL BEARINGS	4200-4300	Polyamide cage	-	No suffix	TVH	TN9	T
		Without filling slot	-	A	-	A	B
		Internal clearance (if diff. from normal radial clearance)	-	-	-	C2 / C3 etc.	C2 / C3 etc.
ANGULAR CONTACT BALL BEARINGS	7000 / 7200/ 7300 / 7400 7800 (71800) 7900 (71900)	Contact angle 30°	No suffix	-	-	A	A
		Contact angle 40°	B	B	B	B	B
		Polyamide cage	T2	A	TVP	P	T85 / TYN
		Pressed steel cage	No suffix	-	-	J	W
		Solid brass cage	L1	M	M	M / MB	No suffix
		Universal design	G	G	UA / UO / UL*	CB / G	G / SU
DOUBLE ROW SELF-ALIGNING BALL BEARINGS	1200 / 1300 2200 / 2300 11200 / 11300	Pressed steel cage	J	No suffix	-	J1	No suffix
		Polyamide cage	T2	G15	TVH	TN9	T
		2 contact seals	-	EE	2RS	2RS1	DDU
		Internal clearance (if diff. from normal radial clearance)	C2 / C3 etc.	C2 / C3 etc.	C2 / C3 etc.	C2 / C3 etc.	C2 / C3 etc.
		Tapered bore 1:12	K	K	K	K	K
DOUBLE ROW ANGULAR CONTACT BALL BEARINGS	3200-3300 5200-5300	Contact angle 32° to 35° with slot	3xxxS	3xxxB	No suffix	No suffix	No suffix
		Contact angle 25° to 30° without slot	5xxxS	3xxxA	B	A	B
		Polyamide cage	T2	G15	TVH / TVP	TN9	T
		Pressed steel cage	No suffix	No suffix	No suffix	No suffix	J
		1 or 2 pressed steel shields	5xxxSCZZ	5xxx ZZ	Z / ZZ	Z / ZZ	Z / ZZ
		1 or 2 contact sealed type	5xxxSCLLD	5xxx EE	HRS / 2HRS	RS1 / 2RS1	RSR / 2RSR
		1 or 2 non contact seals	5xxxSCLLM	-	RSR / 2RSR	-	ZR / 2ZR
Internal clearance (if diff. from normal radial clearance)	C2 / C3 etc.	C2 / C3 etc.	C2 / C3 etc.	C2 / C3 etc.	C2 / C3 etc.		
THRUST BALL BEARINGS	51100-51200 51300-51400	Pressed steel cage	J	No suffix	No suffix	No suffix	No suffix
		Solid brass cage	-	-	M, MP	M	M
		Polyamide cage	T2	-	-	-	-
FOUR-POINT CONTACT BALL BEARINGS	QJ200 - QJ300	Polyamide cage	T2X	-	TVP	-	-
		Solid cage	L1	MA	MPA	MA	No suffix
		Internal clearance (if diff. from normal radial clearance)	C2 / C3 etc.	C2 / C3 etc.	C2 / C3 etc.	C2 / C3 etc.	C2 / C3 etc.

The interchanges are given for information only and you should check that the chosen product corresponds to your requirements. In case of doubt, please do not hesitate to contact us.

*Several specific internal clearances on universal design.

For **NTN** alternative products, please contact us.

Prefixes & suffixes

PREFIXES FOR BALL BEARINGS		
MATERIAL		
Prefix	Brand	Description
F-	NTN	Stainless steel ball bearing
S	SNR	Stainless steel ball bearing
S-	NTN	Material in ceramic
TA- / TAB-	NTN	Nitrided steel
TM- / TMB-	NTN	Special heat treatment
TS2-	NTN	Special heat treatment up to 160 °C
TS3-	NTN	Special heat treatment up to 200 °C
TS4-	NTN	Special heat treatment up to 250 °C
COMPONENT		
2-	NTN	Only applies to inner and outer ring
5-	NTN	Concerns balls only
DIMENSION		
W-	NTN	Modified width
R-	NTN	Inch dimensions
SPECIAL RANGE		
U-RSH	NTN	Sensor bearing
7MC3-	NTN	Outer ring with ceramic coating
7MP-	NTN	Plastic-vulcanised outer ring
AC-	NTN	Anti-rotation protection
EC-	NTN	Expansion compensation for general purposes
EC1-	NTN	Expansion compensation for high temperatures (max. 150 °C)
EC2-	NTN	Expansion compensation for particularly high temperatures (max. 180 °C)

SUFFIXES FOR BALL BEARINGS		
COMPONENT		
Prefix	Brand	Description
/2AS	NTN	Standard Grease
/5K	NTN	Standard Grease
2RS	SNR	Contact seal on both sides - Only for stainless steel deep groove ball bearings
A	NTN	Polyacryl material for the seal
A1	NTN	Fluorine material for the seal
A2	NTN	Silicon material for the seal
Dxxx	SNR	Grease type if non standard
E	SNR	Contact seal on one side
EE	SNR	Contact seals on both sides
F1	NTN	Machined steel cage
F2	NTN	Machined stainless steel cage
FG1	SNR	Food grade LUBSOLID™
G14	SNR	Polyamide 6.6 cage
G15	SNR	Polyamide 6.6 cage with glass fibers
J	NTN	Pressed steel cage
JR	NTN	Pressed rivet cage
JR2	NTN	Cage with reinforced type of pressed steel
L1	NTN	Machined brass cage
L1B	NTN	Machined brass cage centered on balls
LB, LLB	NTN	Nitrile non-friction seal
LH, LLH	NTN	Nitrile low torque seal
LP03	NTN	Standard solid grease

SUFFIXES FOR BALL BEARINGS		
COMPONENT		
Prefix	Brand	Description
LP09	NTN	Food grade solid grease
LU, LLU	NTN	Nitrile double lip contact seal
M	SNR	Massive brass cage, centered on balls
MA	SNR	Massive brass cage, outer ring guided
MB	SNR	Massive brass cage, centered on inner ring
QT	NTN	More than 50% grease filling rate
T2	NTN	Polyamide resin molded cage
T2X	NTN	Polyamide 6.6 + glass fiber 25%
U	NTN	Open bearing with existing groove to put seal afterwards
Y	NTN	Pressed brass cage
Z, ZZ	NTN/SNR	Steel shield
Z1, ZZ1	NTN	Stainless steel shield
DESIGN		
/GH	NTN	Heavy preload
/GL	NTN	Light preload
/GM	NTN	Medium preload
/GN	NTN	Normal preload
A	SNR	Double row angular contact ball bearings: PA66 + glass fiber cage; 25° contact angle; no filling slot Double row deep groove ball bearings: PA66 + glass fiber cage; no filling slot
B	NTN	Single row angular contact: 40° contact angle
BG	NTN	40° contact angle, universal design
C2	NTN/SNR	Radial internal clearance, C2 class
C3	NTN/SNR	Radial internal clearance, C3 class
C4	NTN/SNR	Radial internal clearance, C4 class
C5	NTN/SNR	Radial internal clearance, C5 class
CM	NTN	Special normal radial internal clearance with tighten tolerances
CSnn-n	NTN	Special clearance
K	NTN/SNR	Tapered bore, taper 1:12
N	NTN/SNR	Groove for snap ring on outer ring
N2	SNR	Anti-rotation slots on outer ring
NR	NTN/SNR	Groove and snap ring on outer ring
P2	NTN/SNR	Tolerance class 2
P4	NTN/SNR	Tolerance class 4
P5	NTN/SNR	Tolerance class 5
P6	NTN/SNR	Tolerance class 6
P63E	NTN	P6 precision class + C3 internal clearance; electric motor quality
S	SNR	Spherical outer diameter
W, W-1	NTN	Slot or knock out hole on ring
X1, X2, Xn...	NTN	Chamfer modification
SPECIAL RANGES		
EMTR	SNR	Electric motor product range
F6xx	SNR	TOPLINE range for very high temperature - Maximum 350°C
FT150, FT150ZZ	SNR	TOPLINE range for high temperature - Maximum 150°C
HT200, HT200ZZ	SNR	TOPLINE range for high temperature - Maximum 200°C
HVZZ	SNR	TOPLINE range- High speed bearings with shields on both sides
LT, LTZZ	SNR	TOPLINE range for low temperature





CYLINDRICAL ROLLER BEARINGS



ULTAGE® NO TIME OUT



Cylindrical roller bearings

Defined according to ultimate design rules, the **NTN ULTAGE™** cylindrical roller bearings set the new performance benchmark for your industrial equipment and machines.

Our high-resistance polyamide cage technology, a unique solution on the market, extends the field of use of **NTN** bearings to demanding applications.

Check out a reliable solution for minimising your maintenance operations.

ULTAGE™, setting the standard for supreme performance

NTN®

NTN - Single-row cylindrical roller bearings



Thanks to their rolling elements with line contact on the raceways, the cylindrical roller bearings can support high radial loads. The rollers are guided by shoulders on the outer and/or inner ring and are therefore suitable for high speed applications. Cylindrical roller bearings are separable, allowing them to be easily mounted and disassembled even when interference fits are required.

Technical features

5 configurations of ring shoulders are available:

- NU & N are non locating bearings and can't support any axial load
- NJ, NF & NUP are locating bearings. NJ & NF provide an axial guidance through the bearing in one direction; in the two directions for the NUP design

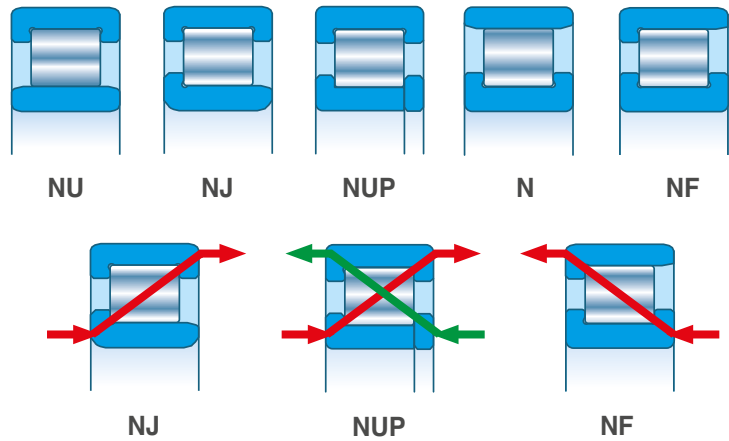

6 main ISO dimensions series:

From the lightest 10.. to the heaviest 4..

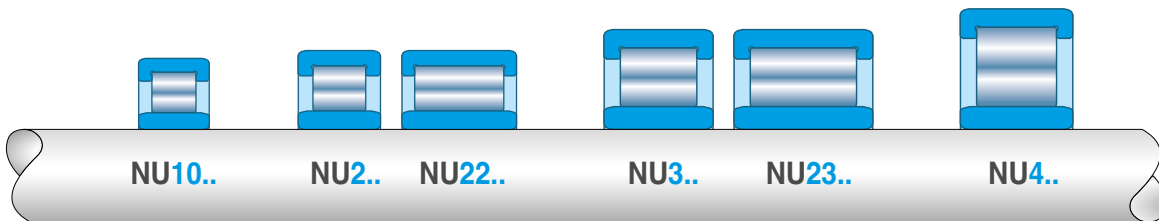

3 technologies of cage:

- Polyamide (T2X), standard type: economic, light weight and quiet operation
- Pressed steel (no suffix), standard type for non E design
- Brass cage (massive G1 or riveted L1) for the largest series and demanding applications



Designations

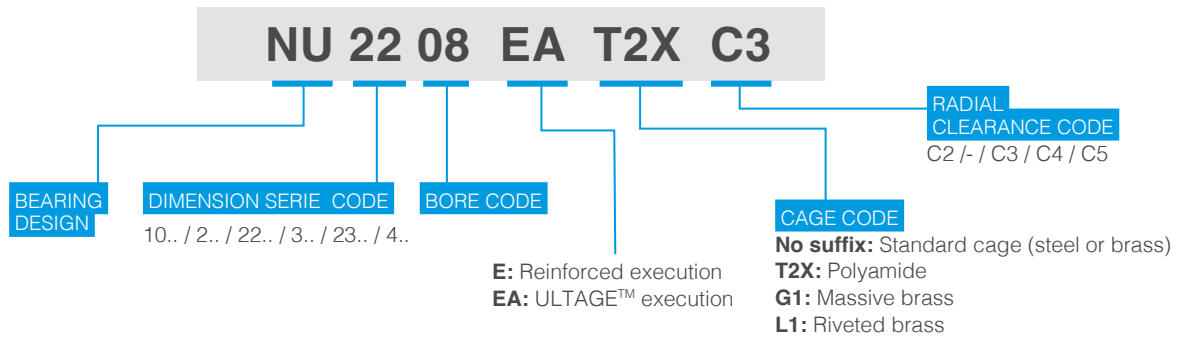

ULTAGE™ offer

ULTAGE™

ULTAGE™ performance series for NU, NJ, NUP, N and NF types in the ISO dimension series 2.., 22.., 3.. and 23..

- Rollers with advanced profile, for an optimal contact stress distribution on the raceways and reduction of edge stresses
- Optimised internal specification for lower operating temperature and improved allowable rotation speed
- High performance glass-fibre reinforced polyamide, for high rotation speed and long grease service life as well as quiet operation

Benefits from using ULTAGE™ (compared to previous design):

- Higher level of dynamic load Cr, one of the highest on the market
- Operation under larger misalignment, up to 2 mrad
- Longer service life
- Lower operating temperature for higher rotation speed, under oil lubrication



A step ahead with quality



+7%
DYNAMIC LOAD CAPACITY CR



+20%
SERVICE LIFE



+20%
ALLOWABLE SPEED

Previous designation

New designation

NU 208 E T2X C3

NU 208 EA T2X C3

Range overview

Bore code		04	05	06	07	08	09	10	11	12	13	14	15	16	17	18	19	20	22
Bore diameter Ød [mm]		20	25	30	35	40	45	50	55	60	65	70	75	80	85	90	95	100	110
Dimension series	2..EA	T2X	T2X	T2X	T2X	T2X	T2X	T2X	T2X	T2X	T2X	T2X	T2X	T2X	T2X	T2X	T2X	G1*	G1*
	22..EA	T2X	T2X	T2X	T2X	T2X	T2X	T2X	T2X	T2X	T2X	T2X	T2X	T2X	T2X	T2X	G1	G1	G1
	3..EA	T2X	T2X	T2X	T2X	T2X	T2X	T2X	T2X	T2X	T2X	T2X	T2X	G1	G1	G1	G1	G1	G1
	23..EA	T2X	T2X	T2X	T2X	T2X	T2X	T2X	T2X	T2X	T2X	T2X	T2X	G1	G1	G1	G1	G1	G1

(*): T2X polyamide cage is the standard cage except for bore codes 20 and 22, with massive brass G1

NTN - Double-row cylindrical roller bearings

Double row cylindrical roller bearings are designed for very heavy loaded applications. With cages, they offer the best compromise for moderate to high rotation speed; without cage (full complement type), they incorporate the maximum number of rollers for the maximum load capacity.



With cages

Non locating bearing

NN49..(K) and NNU49..(K) Bore diameter $\varnothing d = 100 \text{ mm} - 500 \text{ mm}$

NN30..(K) Bore diameter $\varnothing d = 25 \text{ mm} - 460 \text{ mm}$

For heavy loaded applications, under moderate to high rotation speed.

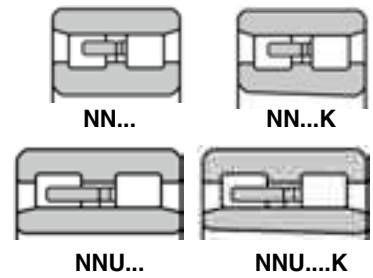

Full complement type

Locating bearing

SL01-48.. and SL01-49.. Bore diameter $\varnothing d = 50 \text{ mm} - 400 \text{ mm}$

Semi-locating bearing

SL02-48.. and SL02-49.. Bore diameter $\varnothing d = 50 \text{ mm} - 380 \text{ mm}$

For extremely loaded applications, under low to moderate speed (large construction machinery, steel industry machinery...).

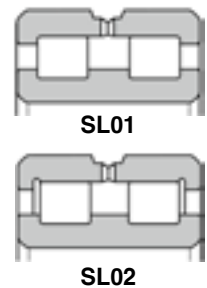

Full complement type - Bearing for sheave

SL04-5.. Bore diameter $\varnothing d = 40 \text{ mm} - 440 \text{ mm}$

- Locating bearing
- Outer ring phosphate coated
- With or without snap rings on outer ring
- With seals or shields
- With or without relubrication on outer ring

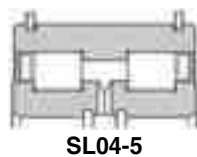

SL04-5



NTN - Four-row cylindrical roller bearings

4R series for roll necks of steel rolling mill

- Bore diameter $\varnothing d = 100 \text{ mm} - 1\,030 \text{ mm}$
- Plain rollers or hollow rollers with pin cage for the highest load rating
- Through hardened or case hardened steel for better crack and shock resistance
- Corrosion resistance with phosphate coatings
- Various configuration of seals, ring designs, bores (tapered bore, circulating oil groove, ...)



Interchange table, prefixes & suffixes

Technical Specification	NTN	SNR	INA/FAG	SKF	NSK
DESIGNATION					
NU / NJ / NUP / N / NF	NU / NJ / NUP / N / NF	NU / NJ / NUP / N / NF	NU / NJ / NUP / N / NF	NU / NJ / NUP / N / NF	NU / NJ / NUP / N / NF
NU without inner ring	RUS...	RNU...	RNU...	RNU...	RNU.../RUS...
N without outer ring	RNH...	RN...	RN...	RN...	RN...
2 row full complement series	SL01-	-	SL01....	NNC...	RS-...
	SL02-....	-	SL02-...	NNCF / NNCL	RSF-....
2 row full complement for sheaves	SL04-5...	-	SL045...	NNF5...	RS-5...
CAGE					
Polyamide cage	T2X	G15	TVP2	P	T
Pressed steel cage	without suffix	-	JP3	J	W
Brass cage	G1, L1	M	M1, M1A, MPAX	M, ML	M, MA1, MBR, MR
EXECUTION					
Increased load design	E, EA	E	E	EC	E
Radial clearance (deviating from normal radial clearance)	C2, C3, C4	C2, C3, C4	C2, C3, C4	C2, C3, C4	C2, C3, C4

The interchanges are given for information only and you should check that the chosen product corresponds to your requirements. In case of doubt, please do not hesitate to contact us.

PREFIXES FOR CYLINDRICAL ROLLER BEARINGS			
Prefix	Brand	Characteristics	Description
TS2-	NTN	Heat treatment	Heat stabilisation for use up to 160 °C, for rings and rollers
2TS2-	NTN	Heat treatment	Heat stabilisation for use up to 160 °C, for rings only
TS3-	NTN	Heat treatment	Heat stabilisation for use up to 200 °C, for rings and rollers
2TS3-	NTN	Heat treatment	Heat stabilisation for use up to 200 °C, for rings only
E-	NTN	Material	Carburising steel, for all components
HL-	NTN	Execution	HL- treatment for rollers, for improved lubrication
7MC3-	NTN	Execution	Ceramic coating on the outer ring for electric insulation
6MX-	NTN	Execution	Phosphate coating on inner ring
MX50-	NTN	Execution	Phosphate coating "RUSTGUARD" on rings and rollers

SUFFIXES FOR CYLINDRICAL ROLLER BEARINGS			
Suffix	Brand	Characteristics	Description
T2X	NTN	Component	PA46 glass fibre reinforced polyamide cage
G1	NTN	Component	Massive brass cage, outer ring guided for NU, NJ and NUP
L1	NTN	Material	Riveted brass cage, outer ring guided
N	NTN	Execution	Groove on outer diameter of outer ring
NR	NTN	Execution	Groove on outer diameter of outer ring + snap ring
HT	NTN	Execution	For high axial thrust load
K	NTN	Execution	Tapered bore



TAPERED ROLLER BEARINGS

RESISTS ALL, EXCEEDS COMPARISON



Inch or metric, the range of **NTN** tapered roller bearings covers all of your needs and will bring you the highest reliability whatever the conditions of use.

Available in our logistics center dedicated to distribution, our offer has been designed to achieve one goal: your satisfaction!

NTN

NTN and SNR - Tapered roller bearings

The tapered roller bearing consists of 2 loose elements: the inner ring (cone) with tapered rolling elements + the cage (we could also say “the mounted cone”) and the outer ring (cup).

This is the best bearing solution for supporting combined axial & radial heavy loads.

The single row type is usually used by pair, the operating clearance or preload is adjusted during the mounting of the bearings.

A set of preloaded tapered roller bearings offers, in addition to a high load capacity, the necessary high rigidity required inside the gearboxes or transmission.



Benefits

A complete range of tapered roller bearings from the world's second largest manufacturer (approx. 100 million units/year), with ISO metric and ABMA inch series.

- Under **NTN** brand, **complete ranges of metric and inch series**, with high technology products
 - A metric range that covers all the market needs
 - A numerous inch range (>270 series), that is the best alternative to the market leader
 - High quality steels, with case hardened steel and through hardened steel
 - The larger sizes under the label ULTAGE™, with the highest performance on the market
 - 2 and 4 rows for specific applications
- Under **SNR** brand, **a compact range of metric series** that covers the **essential needs** with all the **benefits of a premium brand** without any technical compromise
 - An “Easy to Work” range, with only 1 bearing part number per dimension
 - New opportunities of competitiveness in the European market
 - High quality products, a range approved by many major European OE customers

NTN and **SNR** ranges represent approximately 1900 part numbers in the European gross price list, to meet the market needs with the adequate tapered roller bearing.



Metric series range overview

NTN metric tapered roller bearings, the complete range



- 10 standard metric series, including 1 steeper angle series with suffix D (= 313xx in Europe)
- 3 additional steeper angle series 322xxC, 323xxC (suffix C **NTN** = suffix B in Europe) and T7FCxxx
- Bore diameter from 15 mm to 850 mm (440 mm in catalog)
- Case hardened steel (prefix "4T-") or through hardened steel (suffix "U"), interchangeability for both
- Pressed steel cage
- Tolerance: ISO492 normal class
- Designation:
 - For case hardened steel: **4T-32006X**
 - For through hardened steel: **32018XU**

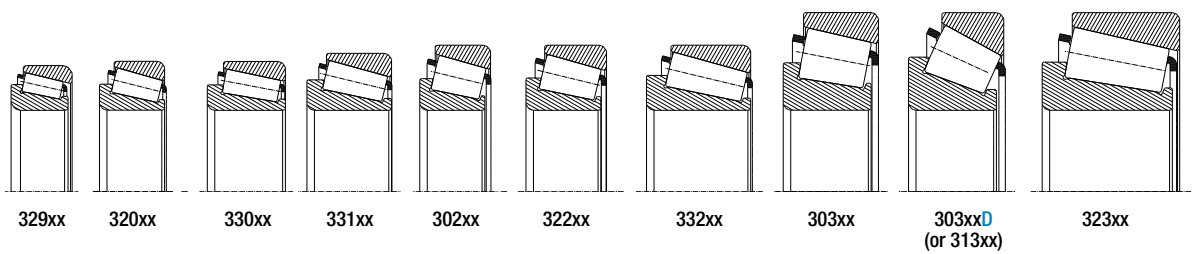

SNR metric tapered roller bearings, the simply smart range



- 9 most popular metric series, including 1 steeper angle series 313xxA
- Outer diameter < 200 mm
- High grade through hardened steel
- Pressed steel cage
- Tolerance: ISO492 normal class
- Easy to work range: designation with only 1 suffix A → **32014A**

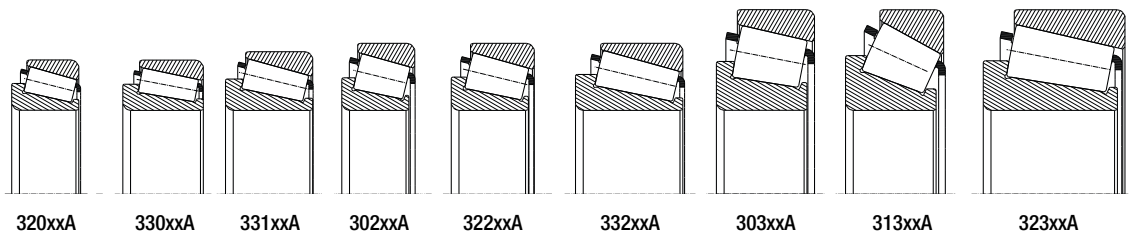

Inch series range overview

NTN inch series tapered roller bearings, the best alternative to the market leader

- >270 series defined according to ABMA standard
- Bore diameter from 12.7 mm to 1270 mm
- 100% case hardened steel, with the prefix “4T-“
- Pressed steel cage
- Tolerance: ANSI/ABMA std 19 class 4 or ANSI/ABMA std 19.1 class K or N for metric J series
- Designation:

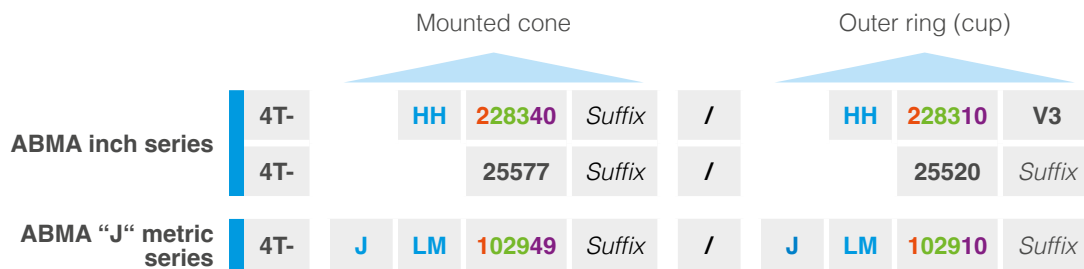

Duty class prefix	Code	Included cup angle	Series number	Component number
EH Extra Heavy series	1	0 to 23°59'59.99"	0-9	Cone -> 30 to 49 (and 20 to 29)
EL Extra Light series	2	24° to 25°29'59.99"	00-99	Cup -> 10 to 19 (and 20 to 29)
H Heavy series	3	25°30' to 26°29'59.99"	000-999	
HH Heavier than Heavy series	4	27° to 28°29'59.99"		
HM Heavy-Medium series	5	28°30' to 30°29'59.99"		
L Light series	6	30°30' to 32°29'59.99"		
LL Lighter than Light series	7	32°30' to 35°59'59.99"		
LM Lighter-Medium series	8	36° to 44°59'59.99"		
M Medium series	9	45° and over, excluding thrust		

- Cone and cup can be managed separately, each cone of the same series could be associated with one cup of the series
- Interchangeability is guaranteed. It is recommended to not mix cones and cups from different origins, for optimal performance after assembly
- A reduced stock allows to generate many bearing combinations:

Example: **25500 series**

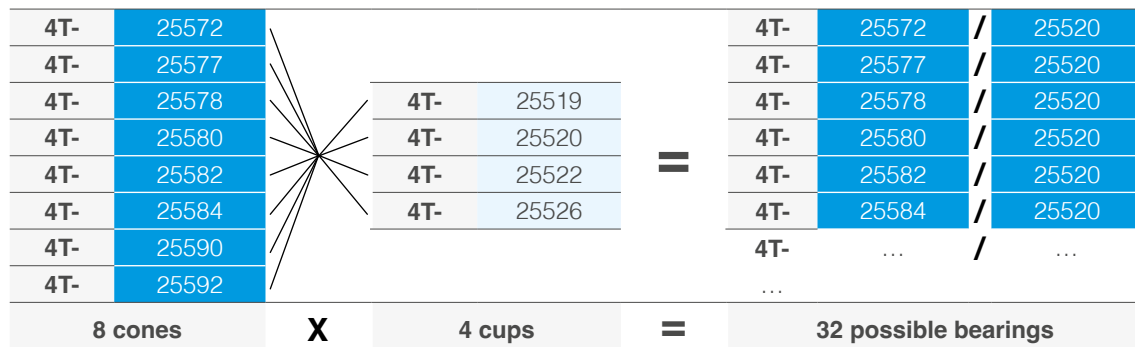

High performance steel

2 technologies of steel, used as standard

Carburised (case hardened) steel

Carburising hardens the steel from the surface to the proper depth, leaving a relatively soft core. This provides hardness and toughness, making the material suitable for impact loads.

Case hardened steel is applied to rollers and both rings and could be identified by the prefix "4T-". It is the standard material for all inch series.

Through hardened steel is obtained from high grade carbon chromium bearing steel. It is applied to larger **NTN** bearings from metric series and to all **SNR** range.

NTN	BEARING SIZE		
	Small	Medium	Large
Inch	Case hardened steel 4T-	Case hardened steel 4T-	Case hardened steel 4T-
Metric	Case hardened steel 4T-	Through hardened steel U	Through hardened steel U

● Case hardened steel 4T- ● Through hardened steel U

2 technologies of NTN steel offer the same basic rating life

Case hardened steel offers additional benefits such as:

- **Better resistance to cracks**, especially in case of high tight fit condition
- **Better resistance to shocks loads**, thanks to its resilient core

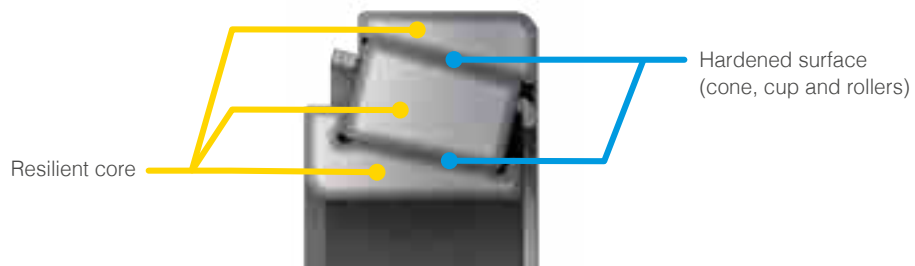

Cross-section of a bearing made of case hardened steel



GOOD TO KNOW!

Inch and metric tolerance systems are not defined in the same way for diameters: in the inch tolerance system, diameters are defined to positive whereas in the metric tolerance system, they are defined to negative (versus nominal diameter).

A special attention has to be put on the shaft diameter definition!!!

Example: Inch bore diam. (in mm) ▶ $\text{Ø } 111.125 \begin{matrix} +0,025 \\ 0 \end{matrix}$

Metric bore diam. (in mm) ▶ $\text{Ø } 105 \begin{matrix} 0 \\ -0,020 \end{matrix}$

ULTAGE™ large size metric series (OD ≥ Ø270mm) deliver longer life, higher load ratings, and higher speed capabilities.

Developed as the new standard of NTN bearings, the ULTAGE™ series will contribute to improvements in industrial machinery today and into the future.

Technical features

ULTAGE™ offers the **highest level of reliability**, thanks to:

Optimised crowning on rollers, for a better load distribution on raceways.

- Basic load rating **Cr: +16%** larger than conventional bearings
- Service life: **x3 longer** than conventional bearings
- **Higher allowable misalignment:** 0.0017 rad (6') is achievable for 0.27Cr, with a minimum required load 0.04C_{or}.

Improved allowable rotation speed, resulting from an optimized design between the roller large face and the cone large rib.

- Lower torque and lower temperature rise.
- Higher rotation speed, **up to +10%**

Improved dimensional stability over time, with a special heat-treatment to the bearing steel, for a better dimensional stability over time and less dimensional changes during operation:

- 1/10 compared with standard through hardened steel
- 1/4 compared with case hardened steel

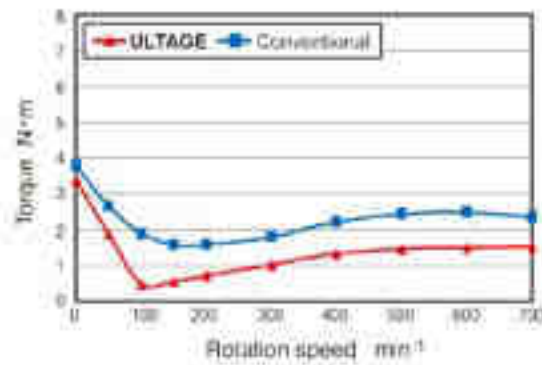
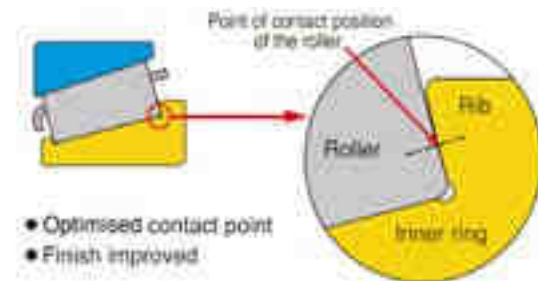
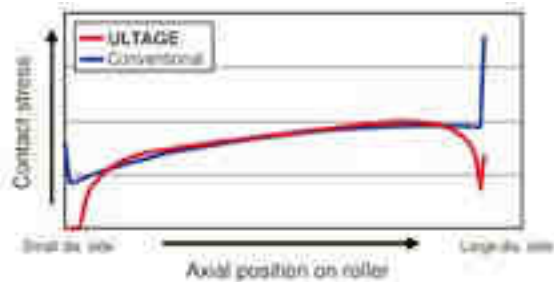

Benefits

			DIMENSION CHANGE
+16%	x3	+10%	1/10

Designation of ULTAGE™ TRB:

Additional suffix "UTG" → 30328 U **UTG**

Interchange tables, prefixes & suffixes

NTN

SNR

PREFIXES	NTN	SNR	TIMKEN	FAG	SKF	KOYO JTEKT
MATERIAL						
Case-hardened steel (inner ring, outer ring and rolling elements)	E-	-			Suffix "/ HA4"	
Case-hardened steel (inner and outer rings)	2E-	-			Suffix "/ HA1"	
Case-hardened steel (inner ring and rollers)	3E-	-			-	
Case-hardened steel (rollers only)	5E-	-			Suffix "/ HA5"	
Case-hardened steel (inner ring only)	6E-	-		W209B	Suffix "/ HA3"	
Case-hardened steel + carbonitriding (inner and outer rings, rollers)	EA-	-				KE
Through-hardening steel + interchangeability	T-	-	-	-	-	-
Case-hardened steel 4T- + interchangeability	4T-	-				
High quality grade case-hardened steel + interchangeability	ET-	-				
High quality grade case hardened steel + carbonitriding + interchangeability	ETA-	-				KE
ECO Top series (ETA steel + Optimised inner geometry) + interchangeability	ECO-	-				KE
NTN Fine Austenite Strengthening Treatment	FA-	-	-	-	-	-
EXECUTION						
Flanged outer ring (metric series)	FL	-			Suffix "R"	
HL- treatment for rollers, for improved lubrication	HL-	-	-	-	-	-
HEAT STABILISATION						
Heat stabilisation up to 160 °C for rings and rollers	TS2-	-	-	-	-	-
Heat stabilisation up to 160 °C for inner and outer ring	2TS2-	-	-	-	-	-
Heat stabilisation up to 200 °C for rings and rollers	TS3-	-		S1	S1	S1
Heat stabilisation up to 200 °C for inner and outer ring	2TS3-	-		-	-	-
Heat stabilisation up to 250 °C for rings and rollers	TS4-	-		S2	S2	S2
DESIGNATION						
Single row tapered roller bearing with special dimensions	CR	-	-	-	-	-
Double row tapered roller bearing with special dimensions, back-to-back arrangement	CRI	-				
Four row tapered roller bearing	CRO	-				
Sealed four-row tapered roller bearing for roll-necks rolling mill, ULTAGE™ range	CROU... LL	-				
Thrust tapered roller bearing	CRT	-	T, TT			
"J-Line metric series, according to ABMA standard. Can be used with all others ABMA prefixes (EL, EH, H, HH, HM, M, LM, L, LL)."	J	J	J	KJ	J	J
Extra Light series (according to ABMA)	EL	EL	EL	KEL	EL	EL
Lighter than Light series (according to ABMA)	LL	LL	LL	KLL	LL	LL
Light series (according to ABMA)	L	L	L	KL	L	L
Light Medium series (according to ABMA)	LM	LM	LM	KLM	LM	LM
Medium series (according to ABMA)	M	M	M	KM	M	M
Heavy series (according to ABMA)	H	H	H	KH	H	H
Heavy Medium series (according to ABMA)	HM	HM	HM	KHM	HM	HM
Heavier than Heavy series (according to ABMA)	HH	HH	HH	KHH	HH	HH
Extra Heavy series (according to ABMA)	EH	EH	EH	KEH	EH	EH
T7FC metric series (according to ISO355)	T7FC...	-	JW...49/ JW...10	T7FC...	T7FC...	T7FC...
T4CB metric series (according to ISO355)	T4CB...	-	JP...49/ JP...10	T4CB...	T4CB...	T4CB...
T2EE metric series (according to ISO355)	T2EE..	-	JF...49/ JF...10	T2EE..	T2EE..	T2EE..

The interchanges are given for information only and you should check that the chosen product corresponds to your requirements. In case of doubt, please do not hesitate to contact us.

SUFFIXES	NTN	SNR	TIMKEN	FAG	SKF	KOYO JTEKT
MATERIAL						
Bore diameter deviation from standard type (inch)	A	A	A			A
Deviating dimensions, for width or radius versus standard type (inch)	AS	AS	AS			
Flanged outer ring (inch series)	B	-	B			B
Change of internal construction	CA	-	CA			
Steeper contact angle for 323xx series (only for metric dimensions)	C	-	B	B	B	C
Average axial clearance of xxx μm (for double row tapered roller bearings)	CSxxx	-		Axxx- xxx	Cxxx	CSxxx
Double outer ring (cup) with groove & oil holes. One hole countered-bored for locking pin	CD	-	CD			
Steeper contact angle (European series 313xx = Japanese series 303xxD)	D	-	313xx	313xx	313xx	D
Double inner ring (cone) or double outer ring (cup)	D	-	D	D	D	D
Lubricating holes on spacer	D1	-				
Raceways with optimised profile for heavy loads	EW	-	-	-	-	-
Matched bearings in "O" arrangement (back to back)	DB	DB	DB	DB	/DB	
Matched bearings in "X" arrangement (face to face)	DF	DF	DF	DF	/DF	
Tandem arrangement	DT	DT		DT	/DT	
Double cup with centering hole, without lubrication groove	DC	-	DC		DC	
Double inner ring (cone) or double outer ring (cup) with lubrication groove and keyway or slot	DW	-	DW			
Only inner ring (cone), for metric	-G	-	Prefix "X"			
Only outer ring (cup), for metric	#G	-	Prefix "Y"			
Seal on inner ring (cone)	L	-	LA, LB		Designation "JK0S"	
Tolerance class 6X	P6X	P6X	6X	P6X	CLN	6X
Tolerance class K (ABMA, J inch series, inch series)	PK	-		Prefix K		PK
Special tolerance	PX1, PX2,...	-	-	-	-	-
Non-interchangeable with bearings of the same basic p/n, for metric series	R	-	R			
Non-interchangeable with bearings of the same basic p/n, for inch series	S	-	S			S
Specification for quick adjustment of the preload	SA	-	-	-	-	-
Low torque specification	ST	-		QCL7C		LFT
Double inner ring (double cone) with tapered bore	TD	-	TD			
Double outer ring (double cup) with tapered outer diameter	TD	-	DT			
Polyamide cage	T2	-	F	TVP / TVH	TN9	
Through-hardened steel SUJ2/100Cr6 + interchangeability (according to ISO355)	U	A	M			J, JR
ULTAGE™ execution	UTG	-	-	Explorer	XL (X-Life)	-
Special chamfer (n = serial number)	X1, X2, Xn...	-	-	-	-	YA1, YA2, YAn ...
Special specification	V1, V2, Vn	-	-	-	-	-
Special groove in the inner ring (for double row tapered roller bearings)	W6	-	DGW		G	SG
Bearing dimensions according to ISO	X	-	X	X	X	J, JR

The interchanges are given for information only and you should check that the chosen product corresponds to your requirements. In case of doubt, please do not hesitate to contact us.





SPHERICAL ROLLER BEARINGS





By offering you the most extensive range of spherical roller bearings on the market, we can now fulfill the needs of all your applications. Working in our modern factories in Europe and Japan, our experts design and manufacture bearings with bores from 25 to 1400 mm.

Our new catalogue presents our full product range, including our exclusive KIZEI®.

The quality of the selected materials, our high manufacturing standards and our unique designs deliver the highest level of performance.

An unrivalled extensive product range!

NTN

NTN and SNR - Spherical roller bearings

Spherical roller bearings are engineered to offer excellent resistance to high temperatures and loads, meaning that they are capable of withstanding the harshest applications:

- Misalignment
- Shock & vibration
- Pollution
- Performance and wear resistance

A wide range of spherical roller bearings is available, offering the best performances on the market.



Benefits*

<p>+24% LOAD CAPACITY</p>	<p>x2 SERVICE LIFE</p>	<p>+20% SPEED LIMITS</p>
--	---------------------------------------	---

Less downtime, more profit!

High quality material

- High quality grade steel – excellent inclusion property

Mastery of heat treatment

- Better wear resistance
- Dimensional stability up to 200°C

Internal design

- Optimised number and geometry of rollers
- Improved surface roughness
- Surface treated cages

Market dynamic load (%)

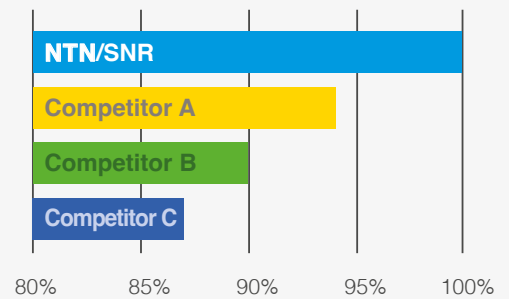

Study carried out in 2021, based on the 3 main European market player catalogues

Range overview

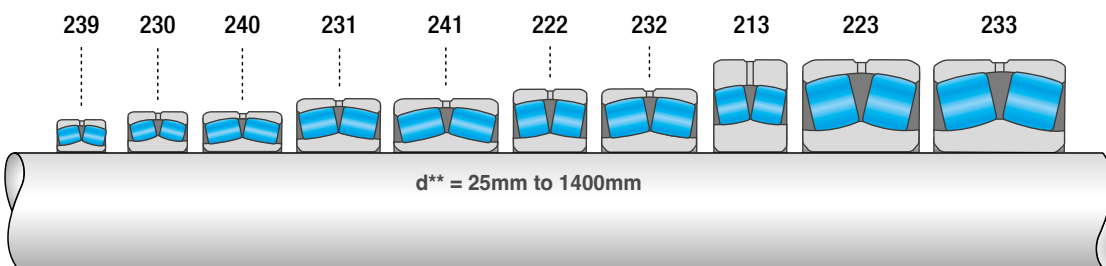

* NTN W33 design and SNR design vs conventional design

** d = bore diameter

Technical features

55% of bearing failures are due to lubrication defects, meaning that lubrication plays a major role in ensuring peak performance.

NTN

SNR

E DESIGN TYPE

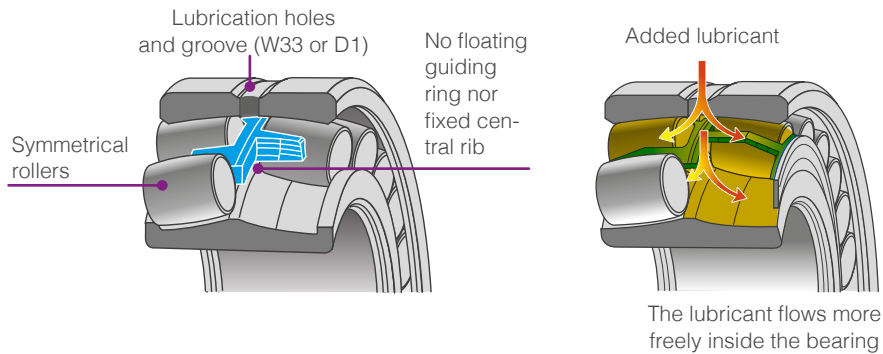

An improved design for better lubrication

- **No central shoulder section:** higher volume available and lubricant can flow more freely, meaning all parts are constantly lubricated
- **Wider lubrication holes and grooves:** design feature simplifies maintenance and relubrication
- **Improved cage materials and design**

E CAGE DESIGNS

Optimised guidance precision for kinematic property maximisation

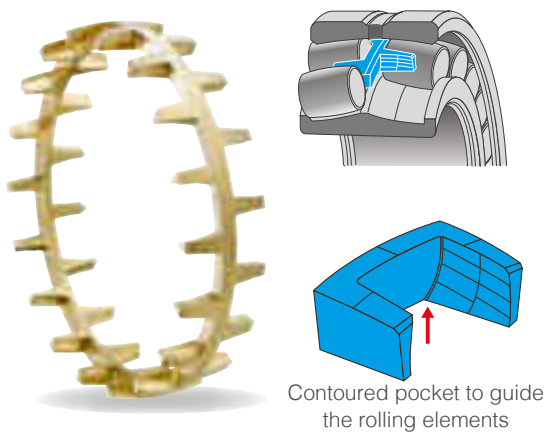

EM – Machined solid brass cage

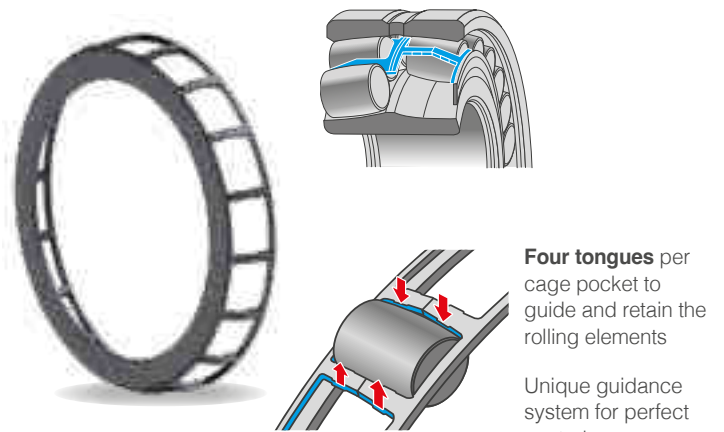

EA – Drawn steel cage

This successful design eliminates the need for a central guide ring, offering you many advantages:

- Less friction and heating in service
- Increased rigidity and stability of the assembly
- Longer life



SNR - EF800 series for high-vibration applications

The EF800 series is equipped with a solid brass cage and is particularly recommended for use in heavy-duty applications and vibration systems.



Enhanced efficiency of your screeners!

Benefits

- Increased service life
- Wider maintenance intervals
- Greater operational profitability

Technical features

- Bearing with symmetrical rollers and machined brass one-piece cage centred on the rolling elements
- No floating guide ring or fixed central shoulder section to avoid any risk of a cage/ring seizure in the event of thermal expansion
- Special tolerances for the outer diameter and bore
- Reduced internal radial clearance: The C4 internal clearance of the EF800 series is reduced to 2/3 of the standard C4 internal clearance in order to obtain improved running properties during operation.

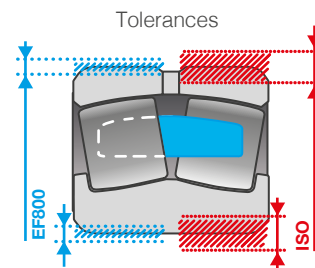

Reduced bore tolerances for cylindrical, tapered and for the outer diameters compared with tolerance ranges of standard series, guaranteeing perfect ring adjustment.

Clearance	22320		Clearance in microns											
	Minimum	Maximum	130	135	140	145	150	155	160	165	170	175	180	185
C4	135	180												
Clearance EF800	150	180												

EF800 series = C4 with reduced tolerance
E.g. EF800 clearance value compared to the clearance value of group C4

Range overview

Further dimensions are possible upon request.

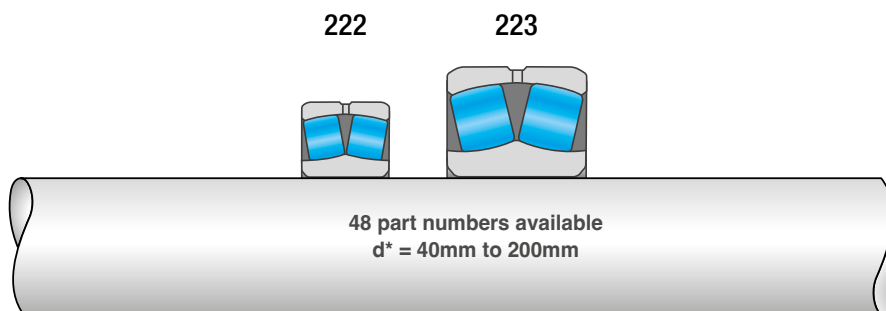

*d = bore diameter

SNR - Sealed spherical roller bearings

To prevent contamination if bearings are used in hostile environments, such as outdoors or in dusty conditions, you are advised to use sealed bearings.

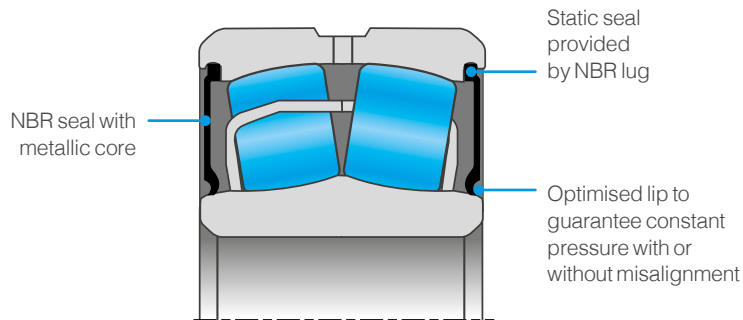

Seals have been tested under the most extreme conditions to guarantee their reliability and performance for your applications

Benefits

- Increased service life
- Wider maintenance intervals
- Greater operational profitability
- Environment protection
- Same load ratings as open spherical roller bearings
- Identical internal design to the open bearings with the EA design
- Non-ISO width with a minimal increase in order to integrate seals, "10X" prefix and the suffix "EE"
- Specially designed NBR seal to guarantee impermeability by means of constant contact pressure of the lip, even in the event of misalignment
- Pre-filled bearing with a quantity and quality of lubricant suited to high loads; no relubrication is required for applications below 70°C

Optionally also available in the low-noise version ("-EEL")

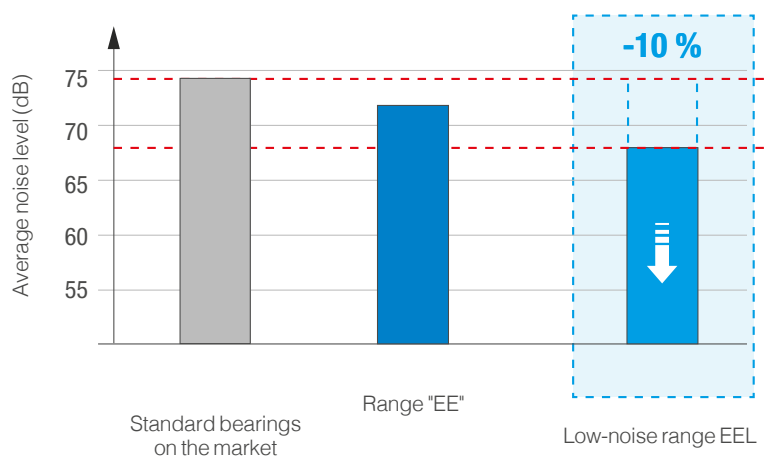

The Low Noise grade significantly reduces the bearing's acoustic impact



ALL-IN-ONE,
make your life easier!

Choose the Spherical
Roller Bearing KITS

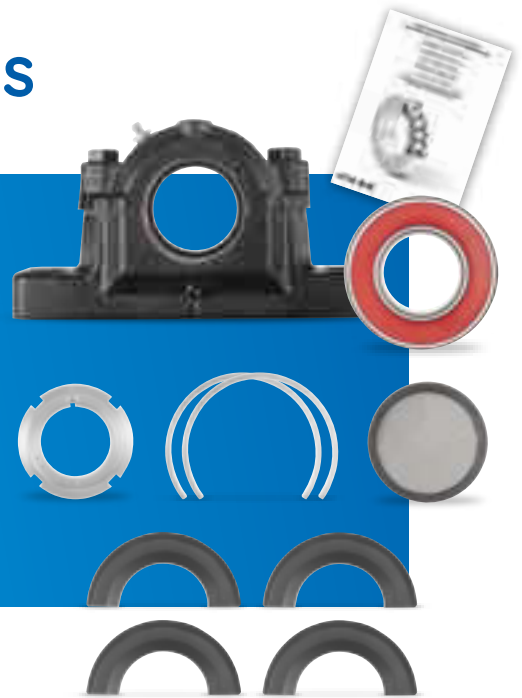

Peace of mind

Offering you an optimal level of service

- **Only one** reference to order (to manage) instead of several
- Kits are composed of specific components to avoid the risk of errors and omissions
- **Fixed or floating** mounting are possible with 1 KIT reference
- Maintenance people **save time** looking for required components. One storage place in the warehouse

Productivity

Improve the performance of your activity

- Economic gain: KIT **cheaper** than retail components
- Sealed spherical bearing KITS: **ECO Friendly!** (vs a standard open bearing)
 - Reduced grease consumption
 - Maintenance interval increased by 3
 - Service life extended by 3

Have a look at our KIT brochure

- Find all range references and component detail
- Multi-market application examples which benefit from kits



[KIZEI][®]

ISO SPHERICAL ROLLER BEARING WITH SHIELDS

NTN is launching an unprecedented solution to extend your bearing service life time! A bearing protected by steel shields on both sides, KIZEI[®] is 100% interchangeable with standard open spherical roller bearings thanks to ISO dimensions. Mounting elements and procedures are identical to that of a standard bearing. This exclusive **SNR** product will dramatically reduce your maintenance costs and improve your equipment reliability!

Armoured to face the dirt!



Brand of **NTN** corporation





SNR - KIZEI® Spherical roller bearings



THE FIRST SPHERICAL ROLLER BEARING WITH METALLIC SHIELDS

NTN Europe's R&D department has pioneered an unprecedented solution to increase the service life of your spherical roller bearings.



Benefits

Improved production performance with longer service life

INITIAL BEARING
1,100 hours in service

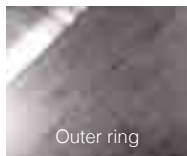

Outer ring

[KIZEI]®
2,200 hours in service

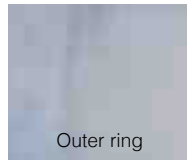

Outer ring



Less deterioration to the bearing after a service life lasting **twice as long**

• Reduced maintenance costs

	Open spherical roller bearing	[KIZEI]®
Life duration	1 month	3 months
Production downtime	12 times/year	4 times/year
Maintenance costs	100	30



Maintenance costs can be reduced by a factor of 3

• Easy to use

ISO dimensions



- Same dimensions as an open spherical roller bearing

Easy mounting process



- Standard accessories
- Possible clearance measurement of K bores

Regreasing frequency divided by 3



- Compared to an open spherical bearing

Range overview and designations

- 60 part numbers available
 - d = 40mm to 140mm
 - From 22208 to 22228
 - Tapered "K" or cylindrical bores
 - Internal radial clearance CN or C3
- Further dimensions and clearances are possible upon request

DESIGNATION

22208EAKW33ZZ

Technical features

- **Same load ratings and speed limits** as open spherical roller bearings
- **ISO dimensions:** 100% interchangeable with an open spherical roller bearing
- **Premium quality nitrided steel plate cage and shields**
Maximised shock and optimised corrosion resistance
- **Extensive range of operating temperatures** from -40°C to +200°C
Dimensional stability up to +200°C
- **KIZEI® is supplied ungreased:** the initial lubrication process is similar to an open spherical roller bearing; 30% of the free volume must be filled with the appropriate grease. The bearing can be lubricated while in service via the dedicated holes and grooves on the outer ring
- **Optimal misalignment**
- **Internal inspection possible** for easier maintenance
- **Easy mounting process:** no special tools are required and the clearance can be checked after mounting

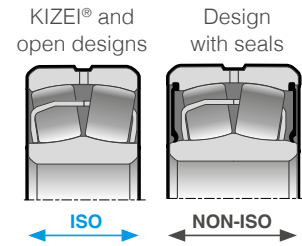

The widest range on the market

	OPEN	[KIZEI]	SEALED
Dimensions	ISO	ISO	Special
Protection	0	+*	++
Grease retention	0	+	++
Temperature range	-40°C to +200°C	-40°C to +200°C	-10°C to +110°C
Limiting speed	++	++	+
Load capacity	+++	+++	+++
Clearance inspection	Yes	Yes	No
Internal control	Yes	Yes	No
Sleeve and nut	Standard	Standard	Special
Supplied already greased	No	No	Yes

*Valid against solid contamination - Not suitable for liquids



NTN and SNR - Thrust spherical roller bearings

Thrust spherical roller bearings are intended for heavy applications, generating large axial loads: injection presses, cranes, pumps, mines, quarries, turbines and equipment for energy.



Technical features

- ISO dimensions: 100% interchangeable
- Drawn steel cage
- Optimised number and geometry of rollers
- Accept radial load up to 50% of axial load
- Maximum misalignment up to 2%

Allowable misalignments

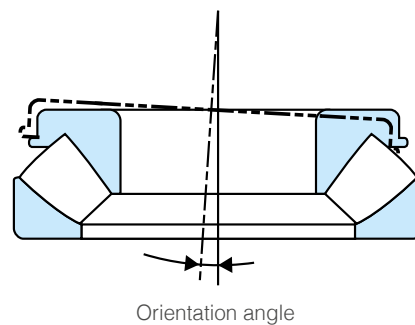

Lubrication: thrust spherical roller bearings are usually heavily loaded and must be lubricated with oil. Due to the internal construction of these bearings, grease lubrication is only possible at low speeds and with limited loads.

Range overview

Thrust spherical roller bearings with drawn steel cage.

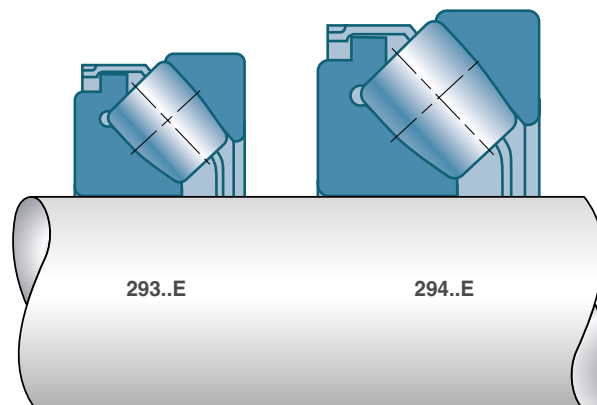

Interchange table, prefixes & suffixes

NTN

SNR

PREFIXES	NTN/SNR	SKF	FAG	TIMKEN
Non-ISO ring width for LL sealed version (NTN)	WA	BS2	WS2	
Non-ISO ring width for EE sealed version (SNR/NTN W33)	10X	BS2	WS2	

SUFFIXES INTERNAL CONSTRUCTION / CAGE DESIGN	NTN/SNR	SKF	FAG	TIMKEN
DESIGN				
Increased capacity design, symmetrical rollers	E DESIGN	E "EXPLORER"	E1 "X-LIFE"	E
Standard internal design, symmetrical rollers	V			C, VSC, Y
Optimised internal design, asymmetrical rollers	B			
CAGE				
Drawn steel cage, inner ring guided	A	No suffix, C, CC	No suffix, BE	EJ
KIZEI® range: Nitrided metal shields on both sides of the bearing	ZZ			
One-piece machined brass cage centered on rollers	M	CA, CAC	E1A, BEA, B-MB, M, MA, MB	EM
One-piece machined brass cage centered on rollers, for high vibration applications, special C4 / C3 internal clearance	F800 / F801	VA405	T41A, T41D	W800
Two glass fibre-reinforced polyamide cages	G15		TVPB (BI)	
Asymmetrical rollers, two solid machined brass cages centered on inner ring	L1	CA, CAC	E1A, BEA, B-MB, M, MA, MB	EM
Solid steel cage. Inner ring guided	F1			
SEALING				
Reinforced seal properties (NBR) on both sides of the bearing. 30% grease-filled (SNR/NTN W33)	EE	2CS, 2RS	2RSR	
Low-noise version (EE sealed parts only)	L			
Reinforced seal properties (NBR) on both sides of the bearing (NTN)	LLS	2CS, 2RS	2RSR	
GROOVE AND HOLES				
Lubrication groove and holes on the outer ring	D1 / W33	No suffix, W33	No suffix, S	W33
Lubrication holes on inner ring (no re-greasing groove)	W34	W26	HA40AB	W94
Groove for stop segment on outer ring	N			
SUFFIXES BORE TYPE				
Cylindrical bore (No suffix)	-	-	-	-
Tapered bore / taper 1:12	K	K	K	K
Tapered bore / taper 1:30	K30	K30	K30	K30

SUFFIXES BEARING CLEARANCE / TOLERANCES	NTN/SNR	SKF	FAG	TIMKEN
Clearance < C2	C1			
Clearance < standard	C2	C2	C2	C2
Standard clearance (No suffix)	CN	CN	CN	CN
Clearance > standard	C3	C3	C3	C3
Clearance > C3	C4	C4	C4	C4
Clearance > C4	C5	C5	C5	C5
Special clearance	CSxx			
P5 rotation precision	P5	P5	P5	P5
P6 rotation precision	P6	P6	P6	P6
P5 rotation precision between IR / OR	PX50	C08	T52BW	C08

Conversion table – Thrust Spherical Roller Bearings

TYPE OF BEARING	Technical Specification	NTN/SNR	FAG	SKF	NSK
Thrust spherical roller bearings Series 29300-29400	Drawn steel cage	No suffix	No suffix	E, EF	No suffix
	Massive brass cage	-	MB	No suffix, EM	M
	Increased capacity design	E	E1	E	E

SKF "Explorer", FAG "X-life" and NSK "HPS" bearings are trademarks registered by their respective companies

The interchanges are given for information only and you should check that the chosen product corresponds to your requirements. In case of doubt, please do not hesitate to contact us.



NEEDLE ROLLER BEARINGS

THE RANGE **MADE IN JAPAN** PREMIUM QUALITY AT YOUR DOOR



NEEDLE ROLLER BEARINGS

NTN provides the widest range of solutions to meet your requirements for needle roller bearings. Premium steel, sturdy design and Japanese manufacturing guarantee optimum reliability and service life. Because our European logistic and technical support teams are close to you, they can provide you with enhanced reactivity.

With its available and competitive wide range, NTN concentrates all its energy on its key concern: you!

NTN



NTN - Needle roller bearings

Needle roller bearings are compact bearing solutions, with various designs, able to support very high radial load in a reduced envelope.

Benefits

- High radial rigidity
- Low inertia
- Suitable for oscillating movements
- Easy mounting
- Cost competitive technology
- Compact dimensions
- High load capacity

Advantages

- Comprehensive range of needle roller bearings, thrust needle and roller bearings, cam and roller followers and individual parts
- More than 50 years of experience for design and manufacturing
- Undisputed market leadership in Japan and No. 2 worldwide for industrial applications
- > 80% coverage of the market leader's range
- Many well-known references from the automotive and industrial sectors rely on **NTN's** needle roller bearing range
- Metric and inch needle roller bearings from one supplier: > 2,300 p/n inside the public price list
- Over 320 million bearings produced every year



DID YOU KNOW?

What is the definition of a needle?
 A needle is a roller that fulfils the 2 following conditions:
 An outer diameter $D_w < 5 \text{ mm}$
 A ratio "Length L_w / Diameter D_w " between 3 and 10.

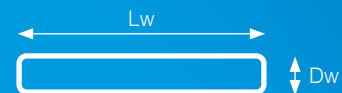

$$3 \leq \frac{L_w}{D_w} \leq 10$$

A step ahead
with quality



Focus on “HK-F” new generation drawn cup

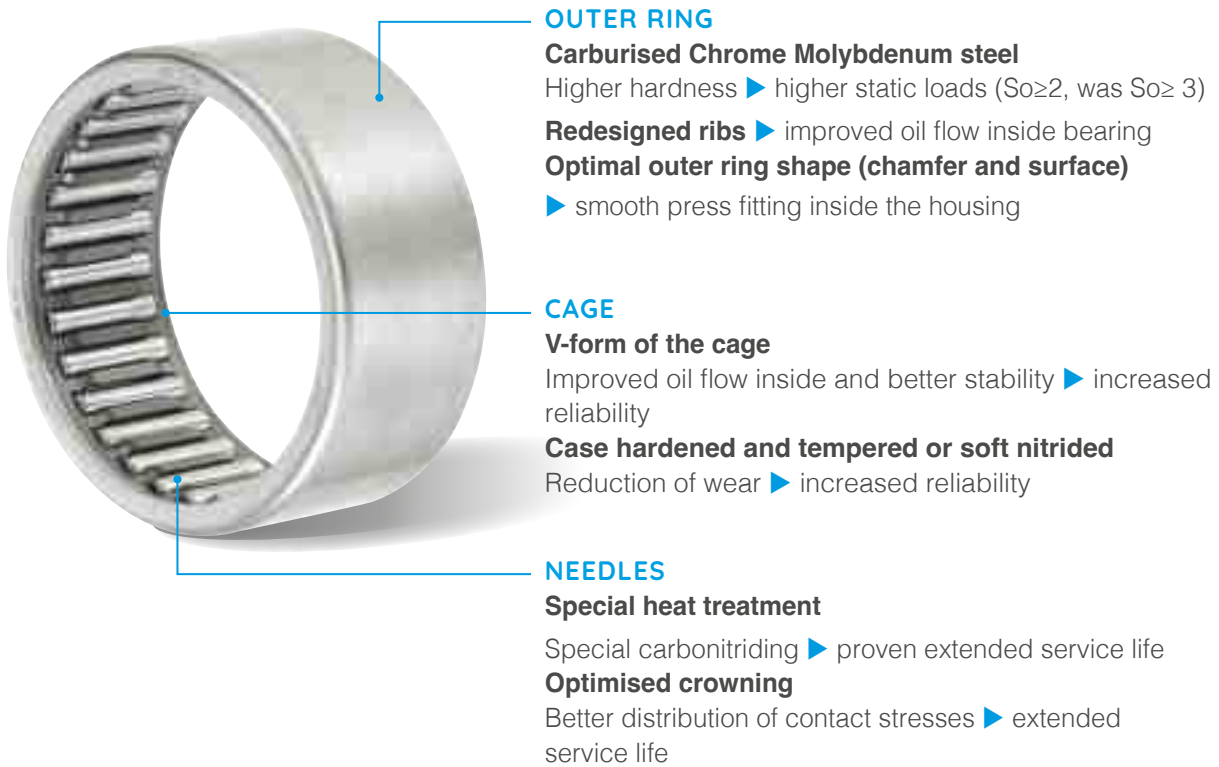

Designations

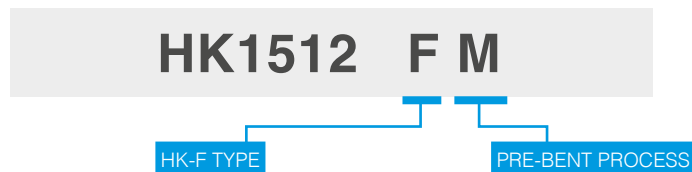

ENHANCED MANUFACTURING PROCESS

No deformation of the outer ring after heat treatment

(« Pre-bent » process, with additional « M » suffix)

- ▶ both sides could be used for mounting

CUSTOMER BENEFITS

- Improved lifetime: 3x longer
- Higher static loads (with lower So): 1.5x greater
- Easier mounting

Interchange tables



DRAWN CUP NEEDLE ROLLER BEARINGS

	NTN	INA	IKO	SKF	KOYO	NADELLA
metric	HK	HK	TLA...Z	HK	BTM	HK
	HK..T2	HK..TV			BFNM	HK..TN
	HK..L	HK..RS		HK..RS	BTM..U	HK..RS
	HK..LL	HK..2RS	TLA..UU	HK..2RS	BTM..UU	HK..2RS
	HK..ZWD	HK..ZW	TLAW..Z	HK..ZW		
	HK..D	HK..AS1			BTM..OH	
	HMK		TAW..Z		BHTM	
	HMK..L		w		BHTM..U	
	HMK..L/LL				BHTM..UU	
	HMK..ZWD		TAW..Z			
	HKS		TA..Z			
	HCK		TAW			
	BK	BK	TLAM	BK	MKM	BK
	BK..T2	BK..TV		BK..TN		
	BK..L	BK..RS				BK..RS
	BK..ZWD	BK..ZW	TLAMW			
	BKS		TAM			

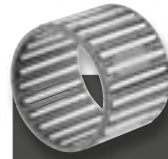

NEEDLE ROLLER AND CAGE ASSEMBLIES

	NTN	INA	IKO	SKF	KOYO	NADELLA
metric	K	K	KT	K	K, RS..R, RP	K
	K..T2	K..TV	KTN	K..TN	K..TN	
	K..ZW	K..ZW	KTW	K..ZW	K..ZW	K..ZW
	KMJ				V.VS, RV	
	KMJ..S					
	KJ..S					
inch	GK				RFNU	
	PCJ	C			WJ, WJC	



CAGE ASSEMBLY FOR CONNECTING ROD

	NTN	INA	IKO	SKF	KOYO	NADELLA
metric	KBK	KBK	KTV..EG		R..P, UR..P	
	KV..S				VP,VPS	
	PK	KZK	KT..EG		VS..P,VE	
	GPK				RFNU	MB
	H					



NEEDLE ROLLER BEARINGS WITH SOLID RINGS

	NTN	INA	IKO	SKF	KOYO	NADELLA	
metric	NK,NK..R	NK	TAF	NK	NQ,NK	NK	
	NK..T2	NK..TV		NK..TN			
	NK+1R, NK..R+1R	NKI	TRI/TAFI	NKI	NQI		
	NKS+IR	NKIS		NKIS			
	NK..T2+1R	NK1..TV		NK1..TN	NQI		
	RNA48	RNA48	RNA48	RNA48		RNA1000	
	NKS	NKS	TR	NKS	NQS	NKS	
	NKZ		TR				
	RNA49, RNA49..R	RNA49	RNA49	RNA49	RNA49		
	RNA49..L	RNA49..RSR	RNA49..U	RNA49..RS			
	RNA49..LL	RNA49..2RSR	RNA49..UU	RNA49..2RS			
	RNA59				RNA59	RNA2000	
	RNA69, RNA69..R	RNA69	RNA69	RNA69	RNA69	RNA22000	
	NA48	NA48	NA48	NA48		NA1000	
	NA49,NA49..R	NA49	NA49	NA49		NA2000	
	NA49..L	NA49..RSR	NA49..U	NA49..RS			
	NA49..LL	NA49..2RSR	NA49..UU	NA49..2RS			
	NA59						
	NA69, NA69..R	NA69	NA69	NA69		NA2200	
	NA69 (double row)	NA69..ZW					
	inch	MR	NCS	BR			
		MR+MI	NCS+PI	BRI			



NEEDLE ROLLER BEARINGS, SEPARABLE TYPE

	NTN	INA	IKO	SKF	KOYO	NADELLA
metric	RNAO	RNAO	RNAF	RNAO		
	RNAO..T2	RNAO..TV	RNAF..N	RNAO..TN		
	RNAO..ZW	RNAO..ZW-ASR1	RNAFW	RNAO		
	NAO	NAO	NAF	NAO		
	NAO..T2	NAO..TV	NAF..N	NAO..TN		
	NAO..ZW	NAO..ZW-ASR1	NAFW	NAO		
	RNA49..S	PNA		PNA		
	NA49..S					



COMPLEX BEARINGS

	NTN	INA	IKO	SKF	KOYO	NADELLA
metric	ARN	ZARN				AXNA
	AXN		IRB			AXNB
	NKX	NKX	NAX	NKX		
	NKX..Z	NKX..Z	NAX...Z	NKX..Z		
	NKX+IR	NKXR+IR	NAXI			
	NKX..Z+IR	NKXR..Z+IR	NAXI..Z			
	NKXR	NKXR	NBX	NKXR		RAXZ
	NKXR..Z	NKXR..Z	NBX...Z	NKXR..Z		
	NKXR..+IR	NKXR..+IR	NBXI			
	NKXR..Z+IR	NKXR..Z+IR	NBXI..Z			
	NKIA59	NKIA	NATA59	NKIA		
	NKIB59..R	NKIB	NATB59	NKIB		



INNER RINGS

	NTN	INA	IKO	SKF	KOYO	NADELLA
metric	1R	IR	IRT	IR	IM	JR
	1R..D	IR..IS1		IR..IS1		
inch	MI (pouce)	PI, LR	IRB	LR		

The interchanges are given for information only and you should check that the chosen product corresponds to your requirements. In case of doubt, please do not hesitate to contact us.



ROLLER FOLLOWERS

	NTN	INA	IKO	SKF	KOYO	NADELLA
metric	RNAB2	RSTO	RNAST..R	RSTO	RSTO	RNA..B
	RNAB2..X	RSTO..XX	RNAST		RSTO..DZ	
	RNA22..LL	RNA22..-2RSR		RNA22..2RSX		
	RNA22..XLL	RNA22..-2RSR-X		RNA22..2RS		
	NAB2	STO	NAST..R	STO	STO	
	NAB2..X	STO..X	NAST	STO..X	STO..DZ	
	NA22..LL	NA22..-2RSR		NA..2RS	NA22..2RS	
	NA22..XLL	NA22..-2RSR-X		NA..2RSX		
	NATR	NATR	NART..R	NATR	CXM..R, NATR	
	NATR..X	NATR..X	NART	NATR..X	CXM, NATR..DZ	
	NATR..LL	NATR..-PP		NATR..PPA	CXM..UUR	
	NATR..XLL	NATR..XPP		NATR..PP	CXM..UU	
inch	NATV	NATV	NART..VR	NATV	CYM..R	FG
	NATV..X	NATV..X		NATV..X	CYM	FGL
	NATV..LL	NATV..PP	NART..VUUR	NATV..PPA	CYM..UUR	FG..EE
	NATV..XLL	NATV..PPX				FGL..EE
	NUTR	NUTR	NURT	NUTR	NUTR	FGU
	NUTR..X	NUTR..X	NURT..DZ	NUTR..X		FGUL
	NUTW					
	NUTW..X					
	NACV	RF..Y	CRY..VR			
	NACV..X	RF	CRY..V			
	NACV..LL	RF..YPP	CRY..VUUR			
	NACV..XLL	RF..PP	CRY..VUU			



NEEDLE AND ROLLER THRUST BEARINGS

	NTN	INA	IKO	SKF	KOYO	NADELLA	
metric	AXK (steel)	AXK	NTB	AXK	TP, AXK		
	AXK (brass)	AXK	NTB	AXK	TP		
	K811	K811	AZK	K811	K811		
	K811..T2	K811..-TV		K811..TN			
	K811..JW						
	K812	K812	AZK	K812	K812		
	K812..T2	K812..-TV		K812..TN			
	K812..JW						
	K874	K893		K893			
	K893	K894		K894			
	AS11	AS	AS	AS	W, AS	CP	
	WS811/ WS812 / WS874 / WS893	WS811/ WS812 / WS874 / WS893	WS	WS	WS		
	GS811/GS812 /GS874 / GS893	GS811/GS812 /GS893 / GS894	GS	GS	GS		
	811	811	AZ	811	811		
	812	812		812	812		
	874	893		893			
	893	894		894			
	inch	NTC	TC				
		NWA	TWA				
		NWB	TWB				



CAM FOLLOWERS

	NTN	INA	IKO	SKF	KOYO	NADELLA
metric	KR	KR	CF..R	KR	KM..R, KR	
	KR..X	KR..X	CF	KR..X	KM, KR..DZ	
	KR..H	KR..SK	CF..BR	KR..SK		
	KR..XH	KR..X, KR..SKX	CF..B			
	KR..LL	KR..PP	CF..UUR	KR..PPA	KM..UUR, KR..2RS	
	KR..LLH	KR..PP, KR..PPSK	CF..BUUR	KR..PPSK		
	KR..XLL	KR..XPP	CF..UU	KR..XPP	KR..DZ, 2RS	
	KR..XLLH	KR..-X-PPSK	CF..BUU		KM..UU	
	KRT		CF..RU1			
	KRT..X					
	KRT..LL					
	KRT..XLL					
	KRV	KRV	CF..VR	KRV	CM..R	GC
	KRV..X	KRV..X	CF..VR	KRV..X		GCL
	KRV..H		CF..VBR	KRV..SK		
	KRV..LL	KRV..-PP	CF..VUUR	KRV..PPA	CM..UUR	GC..EE
	KRV..XLL	KRV..XPP	CF..VUU	KRV..XPP	CM..UU	GCL..EE
	KRV..LLH	KRV..PPSK, KRV..PP	CF..VBUUR	KRV..PPSK		
	KRV..XLLH	KRV..XPPSK, KRV..XPP	CF..VBUU			
	KRVT					
	KRVT..LL					
	KRVT..XLL					
	KRU		CFES..R			
	KRU..X		CFES			
	KRU..LL		CFES..UUR			
	KRU..XLL		CFES..UU			
	KRVU		CFES..V			
	KRVU..X		CFES..VR			
	KRVU..XLL		CFES..VUU			
	KRVU..LL		CFES..VUUR			
	KRMV..XH		CFS..V			
	KRM..XH		CFS			
KRX		CF..SFU				
NUKR	NUKR	NUCF..R	NUKR	DKM..R	NUKR..2SK	
NUKR..X				DKM..DZ		
NUKR..XH						
NUKRT						
NUKRT..X						
NUKRU						
NUKRU..X						
inch	CR		CR..R			
	CR..X		CR			
	CR..H		CR..BR			
	CR..XH		CR..B			
	CR..LL		CR..UUR			
	CR..XLL		CR..UU			
	CR..LLH		CR..BUUR			
	CR..XLLH		CR..BUU			
	CRV	CF	CR..VR			
	CRV..X		CR..V		CR	
	CRV..H		CR..VBR			
	CRV..XH		CR..VB			
CRV..LL	CF..-PP	CR..VUUR				
CRV..XLL	CF..-X-PP	CR..VUU				
CRV..LLH		CR..VBUUR				
CRV..XLLH		CR..VBUU				

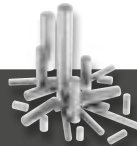

ACCESSORIES

	NTN	INA	IKO	SKF	KOYO	NADELLA
metric	Needles					
	F	NRB	F	RN..BF	LF	BP
	A		A	RN..B	A	BR
	Snap rings					
	WR	WR	WR	SW		
	BR	BR	AR	BR		
	Seals					
	G	G	OS	GS		
	GD	GR	DS	SD		

Prefixes & suffixes

PREFIX	Brand	Characteristics	Description
7E-	NTN	Material	Case-hardened outer ring
8E-	NTN	Component	Case-hardened cage
8Q-	NTN	Component	Nitrided cage
HL-	NTN	Material	HL- treatment on needles, for an improved lubrication

SUFFIX	Brand	Characteristics	Description
A, B, C	NTN	Execution	Modified internal construction
C	NTN	Execution	Special thread for cam followers, for interchangeability with European types
CT	NTN	Other	Welded cage + special heat treatment of the outer ring to increase the service life
D	NTN	Execution	Relubrication hole
D0	NTN	Execution	No relubrication hole (cam followers)
D1	NTN	Execution	Relubrication hole + Relubrication groove
F	NTN	Component	Specially reinforced cage (cam followers with or without axle)
F	NTN	Component	Increased service life (up to 3 times) and simplified assembly for drawn cup needle roller bearings
F1	NTN	Component	Machined steel cage
FM	NTN	Execution	Special heat treatment of the outer ring, to increase service life
H	NTN	Execution	Hexagon socket (cam followers)
J, JW	NTN	Component	Special steel sheet cage
L	NTN	Component	One seal
L1	NTN	Component	Massive brass cage
L3	NTN	Component	Aluminium cage
LL	NTN	Component	2 seals
S	NTN	Component	Welded steel sheet cage
T2	NTN	Component	Polyamide cage
X1, X2, Xn...	NTN	Execution	Modified chamfer
ZW	NTN	Component	2 rows cage
/2AS	NTN	Component	Shell Alvania 2 grease
/3AS	NTN	Component	Shell Alvania 3 grease
/5K	NTN	Component	Multemp SRL grease
/8A	NTN	Component	Alvania EP2 grease
/L588	NTN	Component	Pyronoc Universal N6C grease
/LP03	NTN	Component	Solidlub grease







SOLID LUBRICATION

Solid Lubrication

NTN

SNR

A lubrication solution, developed to provide permanent feeding of the rolling elements.

A big quantity of lubricating oil is stored inside a porous polymer matrix. Under the effect of thermal and mechanical stresses, the oil is slowly released from the matrix.

The solid consistency prevents grease ejection and feeds all rolling elements continuously.

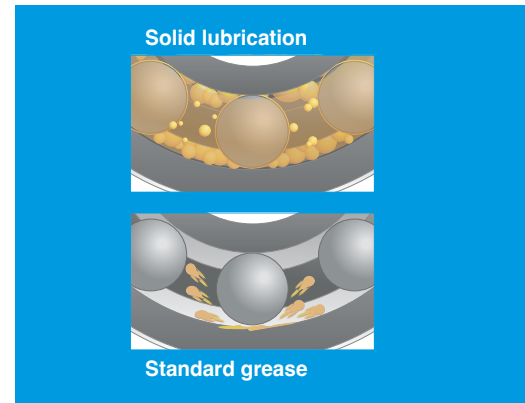

THE STRENGTH OF A GROUP TO BENEFIT FROM THE MOST ADVANCED TECHNOLOGIES

	Oscillations	Centrifugation	High pollution	Speed	High pressure washing
INSERTS	FULL PACK SNR	FULL PACK SNR	FULL PACK SNR	SPOT PACK* NTN	FULL PACK SNR
DGBB					
NRB					
SRB					
CRB					

Suitable for:

- General purposes
- Food grade (NSFH1 certification)

*Spot pack: the matrix is filled by pockets between each rolling elements, thereby providing constant lubrication while maintaining a good level of rotation speed





BEARING UNITS





Self-Aligning Bearing Units

High quality and value, availability, adaptability... This is the motivation behind the development of our bearing unit range. We know that it is important to optimise your investments. Our products, which are ideally suited to your applications, have an exceptional value for money. You can rely on our extensive experience to find a solution which meets your requirements.

Accessible quality



Brand of NTN corporation

SNR - Bearing units with cast iron housings

Sealed deep grooved ball bearing, which can be mounted to a housing by means of its spherical outer ring.

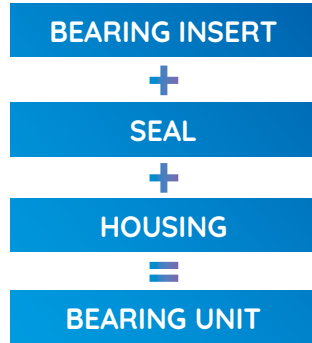

Technical features

- Easy assembly / disassembly
- Robust design
- Universally applicable
- Lubricated and sealed for life
- Quickly ready for operation
- Cost effective
- Compensation of shaft misalignments
- Powder-coated cast iron housings

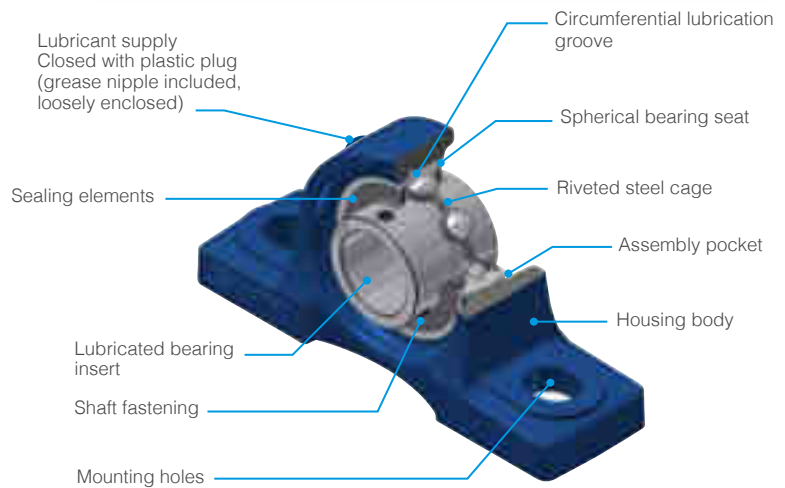

Benefits

One stop shop for all your bearing unit needs

- Save time and money
- Find everything that you need in our comprehensive range of quality products from JIS- and ISO- standards

Improve your reactivity thanks to short lead times

- Control emergency situations
- A high level of product availability in our European Distribution Centre allows you to manage all situations

Optimise the output of your machines with our complete product expertise

- Define the best suitable bearing unit combinations
- Benefit from the advice of our highly skilled engineering team for your specific applications

EX FL 213 CCE

BEARING INSERT

- UC..G2:** Chrome steel bearing insert with shaft fastening with socket set screws, wide design
- US..G2:** Chrome steel bearing insert with shaft fastening with socket set screws, narrow design
- EX..G2:** Chrome steel bearing insert with shaft fastening with eccentric locking collar, wide design
- ES..G2:** Chrome steel bearing insert with shaft fastening with eccentric locking collar, narrow design
- UK..G2H:** Chrome steel bearing insert with shaft fastening with adapter sleeve, wide design
- LK..G2H:** Chrome steel bearing insert with shaft fastening with adapter sleeve, narrow design
- CS:** Chrome steel bearing insert with shaft fastening with interference fit

For customised solutions, combine the cast housings with suitable bearing inserts series:
T20, T04, L3, L4, AGR

HOUSING

- PE** } Pillow block regular design
- PLE** }
- P** }
- PH:** Pillow block high design
- PAE** } Tap base pillow block
- PG** }
- PA** }
- FE** } Four-bolt flange, square design
- F** }
- FCE** } Four-bolt flange with centering rim, round design
- FC** }
- FEE** }
- FTE:** Three-bolt flange, triangular design
- FLE** } Two-bolt flange, oval design
- FL** }
- FLZ:** Two-bolt flange with centering rim, oval design
- FD:** Two-bolt flange, oval narrow design
- FAE** } Two-bolt flange with long hole for shaft adjustment, oval design
- FA** }
- FS:** Four-bolt flange with centering rim, square design
- T:** Take-up unit
- T+WB:** Take-up unit with frame
- SP:** Tensioner unit
- C:** Cartridge unit
- EHE:** Hanger unit

BORE CODE

- Series 200**
201 to 218
(bore- Ø 12 – 90 mm)
- Series 300**
305 to 328
(bore- Ø 20 – 140 mm)

PROTECTIVE COVER

- For use with UC, US, UK, LK, CS**
- SCO:** Open cover
- SCC:** Closed cover
- For use with EX, ES**
- SCOE:** Open cover
- SCCE:** Closed cover
- Housing prepared for cover installation: **N**

The **protective covers** are fixed in housing grooves. For units that are to be fitted with protective covers, housings with suffix **N** must be ordered. Units already ordered with cover(s) are automatically delivered with grooved housings.

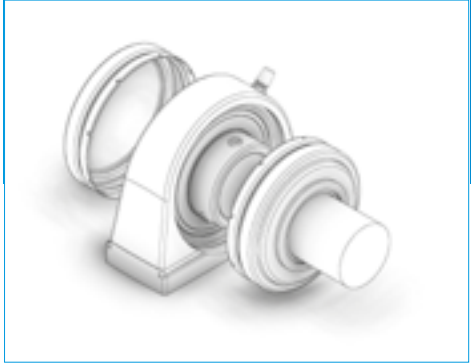



SNR - Bearing units with pressed steel housings



Best economical solution for lightweight constructions

Benefits

- Particularly used in applications where weight is a major constraint

Technical features

- Two-piece housing made from zinc coated sheet steel
- Available as pillow block, flanged or take-up unit
- Suitable for narrow ball bearing inserts set screw type US..G2, eccentric locking collar type ES..G2 and type CS with interference fit
- Made for low to moderate loads & speeds

Designations

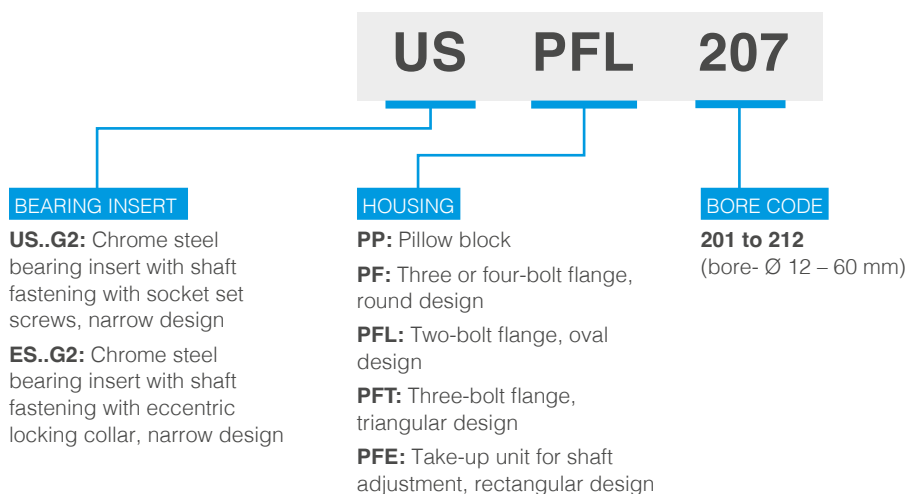

SNR - Bearing units with stainless steel housings



Benefits

Premium line

- Optimum performance with a strong focus on protection from oxidation, mould, bacteria and chemical cleaning agents
- High performance lubricant
- High-quality stainless steel
- Relubrication facility on all housings

Resilient

- Excellent mount stability and impact resistance
- Recess-free housing contact surface to prevent deposits of the process material
- Designed to withstand aggressive cleaning and corrosive environments
- Open or closed protective covers from stainless steel available for all housings

Less downtime, more profitability

- Protective covers for units provide additional protection during high pressure washdown

Technical features

- 100% stainless steel resistant to corrosion: will never chip and contaminate the end product
- Food-grade seal with additional slinger (SUC)
- USDA H1 grease fully compliant with FDA regulations
- Shaft fastening by set screw or eccentric locking collar
- Metal cage
- The protective covers are fixed in housing grooves



SUITABLE FOR THE USE OF LUBSOLID™ BEARING INSERTS

Designations

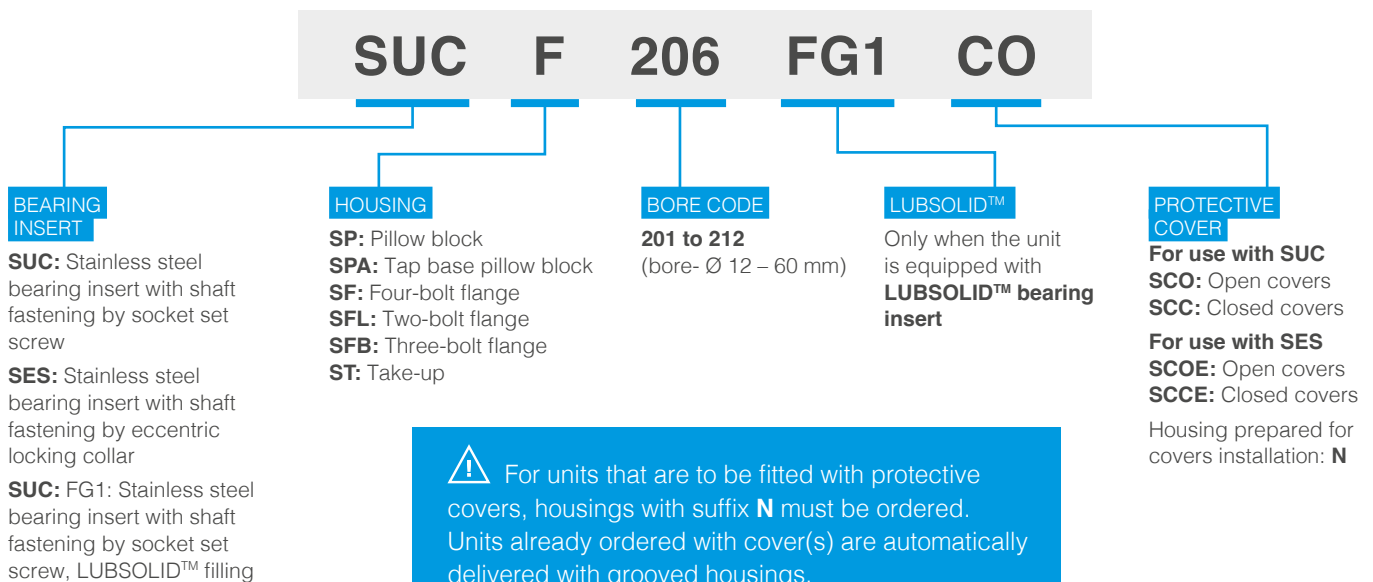



SNR - Bearing units with thermoplastic housings



Benefits

Easy to clean

- Resistant to numerous chlorine-containing and corrosive cleaning solutions
- Insensitive to bacteria formation
- Recess-free housing contact surface to prevent deposits of the process material
- Protective caps for units to provide additional protection against regular wash downs
- Smooth surfaces

Resilient

- Good friction and wear properties
- Mounting holes reinforced with metal bushings
- Equipped with bearing inserts from stainless steel

Technical features

- 100% stainless steel bearing inserts resistant to corrosion: will never chip and contaminate the end product
- All metallic components made of high-quality stainless steel
- Food-grade seal with additional slinger
- High performance lubricant according to NSF H1
- Metal cage

Specific features

- Relubrication facility on all housings
- Additional protection through open or closed end covers (tool-free installation)
- Can optionally be combined with food-grade solid grease bearing insert

Designations

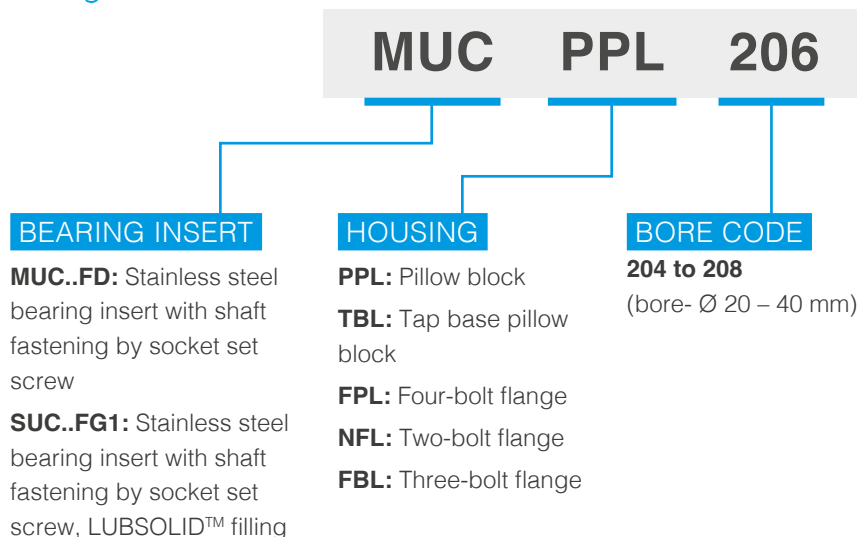

SUITABLE FOR THE USE OF LUBSOLID™ BEARING INSERTS



PROTECTIVE CAP

All housings are equipped with appropriate grooves where caps can snap into place

- CV:** Open cap
- CF:** Closed cap



Protective caps must be ordered separately.

SNR - SENTINEL™ series

SNR stainless steel insert with full-pack LUBSOLID™ (FG1) as lubricant for bearing unit application (thermoplastic or stainless steel housings) is the best opportunity to mix security for food/beverage industries and sustainability for the production equipment.

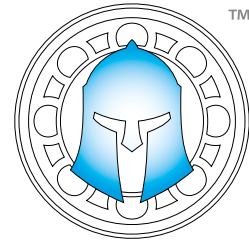

SENTINEL
SERIES

Technical features

- 440C stainless steel bearing, 302 stainless steel cage and slingers
- Specific silicone seals with 302 stainless steel reinforced
- Anti-rotation pin on outer diameter
- **SNR** full-pack LUBSOLID™ (FG1), NSF approval / H1 category code
- Operating temperature: from -10°C to +80°C (100°C peak)

Benefits

- 440C material is the best compromise between load rating capacity and corrosion resistance
- LUBSOLID™ avoid leakage even when bearings are subjected to high vibration and centrifugal force
- Compare with general-purpose food grease lubricant, solid grease is less prone to emulsification and leakage due to water penetration
- LUBSOLID™ with full-pack application confer an additional barrier against pollution





Range overview

- Code bore P/N inserts from 204 to 210 (Shaft diameter 20 to 50 mm)
- Thermoplastic housings: 5 designs
- Stainless steel housings: 6 designs
For housing information, see previous pages about stainless steel and thermoplastic bearing unit

Designations

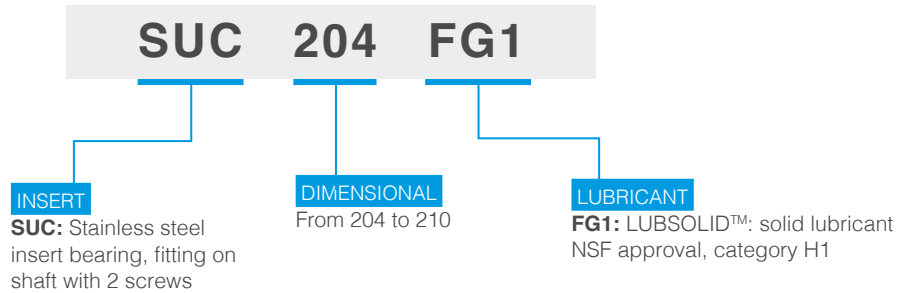

THE ULTIMATE SHIELD AGAINST CONTAMINATION

A commercial success for the past 5 years in America, the SENTINEL™ range is finally coming to Europe! A real revolution in the food-processing market, all bearing units and ball bearings in this series are sealed and equipped with solid lubrication. Resistance to water infiltration and various contaminants, elimination of grease leaks and reduced maintenance interventions make this range the perfect recipe for meeting your environmental, safety and productivity requirements.

SENTINEL™ SERIES, the ultimate shield against contamination.



NTN®

Sealing solutions

Seals for insert bearings		References	Technical characteristics	Benefits
		One-lip seal with protective edge US..G2, US..G1N, US..G2T04, US..G2T20, CUS, ES..G2, ES..G1N, ES..G2T04, ES..G2T20, SES, CES, LK..G2H	Zinc-coated sheet steel retainer* with vulcanised seal. The axially preloaded seal lip from NBR** is located behind a protective edge. * Stainless steel for SES Black-oxide-coated for T20 ** Silicon for SES and design T20	<ul style="list-style-type: none"> • Normal environmental conditions • Medium to high rotation speeds
		One-lip seal CS	Sheet steel retainer over-moulded with NBR material. Axially preloaded seal lip.	<ul style="list-style-type: none"> • Normal environmental conditions • Medium to high rotation speeds
		One-lip seal with slinger UC..G2, UC..G2T04, SUC, MUC..FD, EX..G2, EX..G2T04, CEX, UK..G2H	Zinc-coated sheet steel retainer* over-moulded with NBR and axially preloaded seal lip** + preconnected, zinc-coated sheet steel slinger* for improved protection against mechanical impacts. * Stainless steel for SUC ** Silicon for SUC / Food grade NBR for MUC..FD	<ul style="list-style-type: none"> • Additional protection against particles • Medium to high rotation speeds
		Triple lip seal UC..G2L3, EX..G2L3	Zinc-coated sheet steel retainer with vulcanised triple lip seal. The lips from NBR are axially preloaded and angled outwards. The protective edge of the retainer serves as a safeguard against mechanical impacts.	<ul style="list-style-type: none"> • For medium to heavily polluted environments • Lower rotation speed • Higher friction
		Multiple seal system UC..G2L4, EX..G2L4	Two zinc-coated steel sheet elements with vulcanised seal lips from NBR. The internal retainer is equipped with a radial seal to the inner ring, while the external slinger has a radial seal to the outer ring. A third seal lip is intermediate and acts axially.	<ul style="list-style-type: none"> • For medium to heavily polluted environments • Medium rotation speeds • Lower friction • Suitable for pressure washing
		High-performance seal system UC..AGR, EX..AGR	Zinc-coated steel sheet retainer with vulcanised triple lip seal. The lips from NBR are axially preloaded and angled outwards. The triple lip seal is completely covered by a massive steel protector. The zinc-coated impact shield is additionally equipped with a lip seal and strongly secured on a knurled seat.	<ul style="list-style-type: none"> • For extremely polluted environments • Shock resistant • Low rotation speeds • Suitable for high-pressure washing • Higher friction
		High temperature non-contact seal UC..T20, EX.. T20	Labyrinth seal from two black-oxide-coated steel sheet slinger in parallel arrangement.	<ul style="list-style-type: none"> • For high temperature use • Very low friction

Combination overview

Cast iron housings with chrome steel bearing inserts

BEARING INSERTS								Suitable protective covers for combination with (available for shaft-Ø 12-65mm)*	
		UC2..G2 / UC3..G2	US2..G2	EX2..G2 / EX3..G2	ES2..G2	LK2..G2H	UK2..G2H / UK3..G2H	UC2..G2 / US2..G2 / LK2..G2H / UK2..G2H	EX2..G2 / ES2..G2
HOUSINGS									
Pillow blocks	PE2	UCPE2	USPE2	EXPE2	ESPE2	LKPE2+H	UKPE2+H	SCC2 / SCO2	SCCE2 / SCOE2
	PLE2	UCPLE2	USPLE2	EXPLE2	ESPLE2	LKPLE2+H	UKPLE2+H	SCC2 / SCO2	SCCE2 / SCOE2
	P2 / P3	UCP2 / UCP3	USP2	EXP2 / EXP3	ESP2	LKP2+H	UKP2+H / UKP3+H	SCC2 / SCO2	SCCE2 / SCOE2
	PH2	UCPH2	USPH2	EXPH2	ESPH2	LKPH2+H	UKPH2+H	SCC2 / SCO2	SCCE2 / SCOE2
	PAE2	UCPAE2	USPAE2	EXPAE2	ESPAE2	LKPAE2+H	UKPAE2+H	SCC2 / SCO2	SCCE2 / SCOE2
	PG2	UCPG2	USPG2	EXPG2	ESPG2	LKPG2+H	UKPG2+H	SCC2 / SCO2	SCCE2 / SCOE2
	PA2	UCPA2	USPA2	EXPA2	ESPA2	LKPA2+H	UKPA2+H	SCC2 / SCO2	SCCE2 / SCOE2
Flanged units	FE2	UCFE2	USFE2	EXFE2	ESFE2	LKFE2+H	UKFE2+H	SCC2 / SCO2	SCCE2 / SCOE2
	F2 / F3	UCF2 / UCF3	USF2	EXF2 / EXF3	ESF2	LKF2+H	UKF2+H / UKF3+H	SCC2 / SCO2	SCCE2 / SCOE2
	FCE2	UCFCE2	USFCE2	EXFCE2	ESFCE2	LKFCE2+H	UKFCE2+H	-	-
	FC2	UCFC2	USFC2	EXFC2	ESFC2	LKFC2+H	UKFC2+H	SCC2 / SCO2	SCCE2 / SCOE2
	FEE2	-	USFEE2	-	ESFEE2	-	-	-	-
	FTE2	-	USFTE2	-	ESFTE2	-	-	-	-
	FLE2	UCFLE2	USFLE2	EXFLE2	ESFLE2	LKFLE2+H	UKFLE2+H	SCC2 / SCO2	SCCE2 / SCOE2
	FL2 / FL3	UCFL2 / UCFL3	USFL2	EXFL2 / EXFL3	ESFL2	LKFL2+H	UKFL2+H / UKFL3+H	SCC2 / SCO2	SCCE2 / SCOE2
	FLZ2	UCFLZ2	USFLZ2	EXFLZ2	ESFLZ2	LKFLZ2+H	UKFLZ2+H	-	-
	FD2	-	USFD2	-	ESFD2	-	-	-	-
	FAE2	-	USFAE2	-	ESFAE2	-	-	-	-
	FA2	UCFA2	USFA2	EXFA2	ESFA2	LKFA2+H	UKFA2+H	SCC2 / SCO2	SCCE2 / SCOE2
	FS3	UCFS3	-	EXFS3	-	-	UKFS3+H	-	-
Tensioner- / Hang up- / Cartridge Units	T2 / T3	UCT2 / UCT3	UST2	EXT2 / EXT3	EST2	LKT2+H	UKT2+H / UKT3+H	SCC2 / SCO2	SCCE2 / SCOE2
	T2+WB	UCT2+WB	UST2+WB	EXT2+WB	EST2+WB	LKT2+H+WB	UKT2+H+WB	SCC2 / SCO2	SCCE2 / SCOE2
	SP2	UCSP2	USSP2	EXSP2	ESSP2	LKSP2+H	UKSP2+H	SCC2 / SCO2	SCCE2 / SCOE2
	C2 / C3	UCC2 / UCC3	USC2	EXC2 / EXC3	ESC2	LKC2+H	UKC2+H / UKC3+H	-	-
	EHE2	UCEHE2	USEHE2	EXEHE2	ESEHE2	LKEHE2+H	UKEHE2+H	-	-

* The protective covers are fixed in housing grooves. For units that are to be fitted with protective covers, housings with suffix N must be ordered. Units already ordered with cover(s) are automatically delivered with grooved housings.

Pressed steel housings with chrome steel bearing inserts

HOUSINGS \ BEARING INSERTS			
		US2..G2	ES2..G2
	PP2	USPP2	ESPP2
	PF2	USPF2	ESPF2
	PFL2	USPFL2	ESPFL2
	PFT2	USPFT2	ESPFT2
	PFE2	USPFE2	ESPFE2

Stainless steel housings with stainless steel bearing inserts

HOUSINGS \ BEARING INSERTS					Suitable protective covers for combination with (available for shaft-Ø 12-60mm)*	
		SUC2	SUC2..FG1**	SES2	SUC2 / SUC2..FG1**	SES2
	SP2	SUCP2	SUCP2..FG1	SESP2	SCC2 / SCO2	SCCE2 / SCOE2
	SPA2	SUCPA2	SUCPA2..FG1	SESPA2	SCC2 / SCO2	SCCE2 / SCOE2
	SF2	SUCF2	SUCF2..FG1	SESF2	SCC2 / SCO2	SCCE2 / SCOE2
	SFL2	SUCFL2	SUCFL2..FG1	SESFL2	SCC2 / SCO2	SCCE2 / SCOE2
	SFB2	SUCFB2	SUCFB2..FG1	SESF2	SCC2 / SCO2	SCCE2 / SCOE2
	ST2	SUCT2	SUCT2..FG1	SEST2	SCC2 / SCO2	SCCE2 / SCOE2

Thermoplastic housings with stainless steel bearing inserts

HOUSINGS \ BEARING INSERTS				Suitable protective caps (available for shaft-Ø 15-40 mm)
		MUC2..FD	SUC2..FG1**	
	PPL2	MUCPPL2	SUCPPL2..FG1	CV2 / CF2
	TBL2	MUCTBL2	SUCTBL2..FG1	CV2 / CF2
	FPL2	MUCFPL2	SUCFPL2..FG1	CV2 / CF2
	NFL2	MUCNFL2	SUCNFL2..FG1	CV2 / CF2
	FBL2	MUCFBL2	SUCFBL2..FG1	CV2 / CF2

* The protective covers are fixed in housing grooves. For units that are to be fitted with protective covers, housings with suffix N must be ordered. Units already ordered with cover(s) are automatically delivered with grooved housings.



** LUBSOLID™ filling.

Protective caps & covers

Benefits



- Improvement of safety characteristics (safety at work)
- Protection of the bearing from external influences such as impact loads, dust, dirt or moisture ingress
- Protection against lubricant leakage (especially for covers)
- Can be used for shaft-end or through-shafts

Stainless steel covers for bearing units series

SUFFIX	Description	Cover type	Suitable in combination with bearing insert type:	Design
CC	Bearing unit with narrow cover (closed version)	SCC	Set screw, adapter sleeve, Fit	
CO	Bearing unit with narrow cover for metric shaft (open version)	SCO		
COU	Bearing unit with narrow cover for imperial shaft (open version)	SCOU		
CCE	Bearing unit with wide cover (closed version)	SCCE	Eccentric locking collar	
COE	Bearing unit with wide cover for metric shaft (open version)	SCOE		
COEU	Bearing unit with wide cover for imperial shaft (open version)	SCOEU		
N	Unit / Housing prepared for cover(s) installation	-	/	

Bearing units that are ordered with cover(s) include the housings with grooves. If you want to install the protective covers later, housings with suffix N must be ordered (for example: P210N).

Protective caps for bearing units series

CAP TYPE / SUFFIX	Description	Suitable in combination with bearing insert type:	Design Open / Closed	Notice
PCO	Protective cap for bearing inserts type G1N (open version)	US..G1N / ES..G1N		Protective caps have to be ordered separately from the bearing units.
PCC	Protective cap for bearing inserts type G1N (closed version)			
CV	Protective cap for thermoplastic series (open version)	MUC..FD		
CF	Protective cap for thermoplastic series (closed version)			
-G1N	Bearing insert with groove in the outer ring			

- The installation of protective caps can be done tool free. For mounting the yellow pressed steel caps bearing insert series G1N must be installed to the bearing unit. These bearings have a special groove machined in their outer rings in which the protector can snap into place (for example: US206G1N).
- All thermoplastic housings are equipped with appropriate grooves where caps can snap into place.

Interchange tables

Cast iron self-aligning bearing units

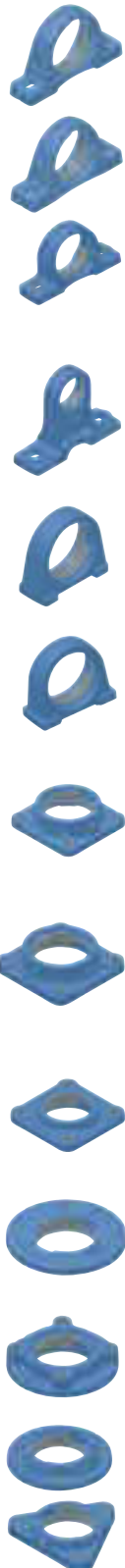
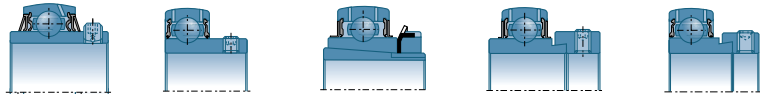

SNR	UCPE	USPE	UKPE..H	EXPE	ESPE
INA	RASEY	PASEY	-	RASE..N	PASE..N
SKF	SY..TF	-	SYJ..KF	SY..WF	SY..FM
RHP	NP	NP..A	NP10..-..K	NP..DEC	NP..EC
SNR	UCPLE	USPLE	UKPLE..H	EXPLE	ESPLE
RHP	SL	SL..A	-	SL..DEC	SL..EC
NTN	UCP..D1*	ASP	UKP..D1;H23..X*	UEL..D1W3**	AELP..D1
SNR	UCP**	USP	UKP..H**	EXP**	ESP
NSK	UCP	-	UKP..D1;H23..X	UEL..D1W3**	AELP..D1W3
ASAHI	UCP	BP	UKP..+H23..	-	KHP
FAG	UCP..-J7	-	UKP..-J7	-	-
KOYO/JTEKT	UCP	-	UKP..+H23..X	NAP	SAP
NTN	UCHP..D1	-	-	UELPHP..D1W3	-
SNR	UCPH	USPH	UKPH..H	EXPH	ESPH
NSK	UCHP..D1	-	-	UELHP..D1W3	-
ASAHI	UCPH	-	-	-	-
KOYO/JTEKT	UCPH	-	-	-	-
SNR	UCPAE	USPAE	UKPAE..H	EXPAE	ESPAE
INA	RSHEY	PSHEY	-	RSHE	PSHE
SKF	SYF..TF	-	-	-	SYF..FM
RHP	SNP	SNP..A	-	SNP..DEC	SNP..EC
NTN	UCUP..D1	ASUP	UKUP..D1;H23..X	UELUP..D1W3	AELUP..D1
SNR	UCPA/UCPG	USPA/USPG	UKPA..H/UKPH..H	EXPA/EXPG	ESPA/ESPG
NSK	UCPA	-	-	UELUP..D1W3	AELUP..D1
ASAHI	UCPA	-	-	-	-
KOYO/JTEKT	UCPA	-	UKPA..+H23..X	-	-
SNR	UCFE	USFE	UKFE..H	EXFE	ESFE
INA	RCJY	PCJY	-	RCJ	PCJ
SKF	FY..TF	-	FYJ..KF	FY..WF	FY..FM
RHP	SF	SF..A	MSF..K	SF..DEC	SF..EC
NTN	UCF..D1*	ASF..D1	UKF..D1;H23..X*	UELF..D1W3**	AELF..D1
SNR	UCF**	USF	UKF..H**	EXF**	ESF
NSK	UCF	ASF..D1/UBF	UKF..D1;H23..X	UELF..D1W3	AELF..D1
ASAHI	UCF	BF	UKF..+H23..	-	KHF
FAG	UCF..-J7	-	UKF..-J7	-	-
KOYO/JTEKT	UCF	-	UKF..+H23..X	NANF	SAF
NTN	UCFS..D1	-	UKFS..D1;H23..X	UELFS..D1W3	-
SNR	UCFS	-	UKFS..H	EXFS	-
NSK	UCFS..D1	-	UKFS..D1;H23..X	UELFS..D1W3	-
ASAHI	UCFS	-	-	-	-
KOYO/JTEKT	UCFS	-	UKFS..+H23..X	-	-
SNR	UCFCE	USFCE	UKFCE..H	EXFCE	ESFCE
INA	RMEY	PMEY	-	RME	PME
RHP	FC	FC..A	-	FC..DEC	FC..EC
NTN	UCFC..D1***	ASFC..D1	UKFCD1;H23..X***	UELFC..D1W3	AELFC..D1
SNR	UCFC	USFC	UKFC..H	EXFC	ESFC
SKF	FYC..TF	-	-	FYC..WF	FYC..FM
NSK	UCFC..D1	-	UKFC..D1;H23..X	UELFC..D1W3	-
ASAHI	UCFC	-	UKFC..+H23..	-	KHFC
KOYO/JTEKT	UCFC	-	UKFC..+H23..X	-	-
SNR	-	USFEE	-	-	ESFEE
INA	-	-	-	-	RFE
SNR	-	USFTE	-	-	ESFTE
INA	-	-	-	-	PCFTR

* Also available in 300 and X-Series (medium size) ** Also available in 300-Series *** Also available in X-Series (medium size) (1) For SP, 4 available boxes

The interchanges are given for information only and you should check that the chosen product corresponds to your requirements. In case of doubt, please do not hesitate to contact us.

NTN range available upon request.

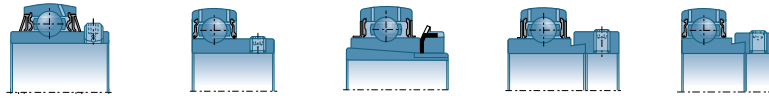

SNR	UCFLE	USFLE	UKFLE..H	EXFLE	ESFLE
INA	RCJTY	PCJTY	-	RCJT	PCJT
SKF	FYTB..TF	-	FYTJ..KF	FYTB..WF	FYTB..FM
RHP	SFT	SFT..A	MSFT..K	SFT..DEC	SFT..EC
NTN	UCFL..D1*	ASFL..D1	UKFL..D1;H23..X*	UELFL..D1W3**	AELFL..D1
SNR	UCFL**	USFL	UKFL..H**	EXFL**	ESFL
NSK	UCFL	ASFL	UKFL..D1;H23..X*	UELFL..D1W3	AELFL..D1
FAG	UCFL..-J7	-	UKFL..-J7	-	-
ASAHI	UCFL	BFL	UKFL..+H..	-	KHFL
KOYO/JTEKT	UCFL	-	UKFL..+H..X	NANFL	SAFL..FM
SNR	UCFLZ	USFLZ	UKFLZ..H	EXFLZ	ESFLZ
INA	-	-	-	RCJ TZ	PCJ TZ
NTN	-	ASFD..D1	-	-	AELFD..D1
SNR	-	USFD	-	-	ESFD
INA	-	FLCTEY	-	-	GLCTE
NSK	-	ASFD	-	-	AELFD
ASAHI	-	BLCTE	-	-	KHLCTE
RHP	-	LFTC..A	-	-	LFTC..EC
SNR	-	USFAE	-	-	ESFAE
INA	-	-	-	-	PSFT
NTN	UCFA..D1	-	UKFA..;H23..X	-	AELFA..D1
SNR	UCFA	USFA	UKFA..H	EXFA	ASFA
NSK	UCFA..D1	-	-	-	-
ASAHI	UCFA	-	-	-	-
KOYO/JTEKT	UCFA	-	-	-	-
NTN	UCT..D1*	AST..D1	UKT..D1;H23..X*	UFLT..D1W3**	AELT..D1
SNR	UCT**	UST	UKT..H**	EXT**	EST
INA	RTUEY	PTUEY	-	RTUE	PTUE
SKF	TUJ..TF	-	-	-	-
RHP	ST	ST..A	MST..K	ST..DEC	ST..EC
NSK	UCT..D1	-	UKT..D1;H23..X	UFLT..D1W3	-
ASAHI	UCT	BT	UKT..+H..	-	KHT
KOYO/JTEKT	UCT	-	UKT..+H..X	-	-
SNR	UCT..+WB	UST..+WB	UKT..H+WB	EXT..+WB	EST..+WB
NSK	UCT..+WB	-	-	-	-
ASAHI	UCT..+WB	-	-	-	-
NTN	-	ASPT2..-10	-	-	AELPT2..-10
SNR	UCSP	USSP	UKSP..H	EXSP	ESSP
RHP	BT	BT..A	-	-	BT..EC
SNR	SPR 1	SPR 11 & 21	SPR 12 & 22	SPR 14 & 24	
INA	-	HUSE	-	-	-
RHP	BT	-	-	-	-
NTN	UCHB..D1				
SNR	UCEHE	USEHE	UKEHE..H	EXEHE	ESEHE
RHP	SCH	-	-	-	-
INA	-	PHEY	-	RHE	PHE
NSK	UCEHE	-	-	-	-
ASAHI	UCECH	-	-	-	-
NTN	UCC..D1	ASC..	UKC..D1;H23..X*	UELCC..D1W3*	AELC..D1
SNR	UCC	USC	UKC..H**	EXC**	ESC
NSK	UCC..D1	-	UKC..D1;H23..X	UELCC..D1W3	-
ASAHI	UCC	-	-	-	-
KOYO/JTEKT	UCC	-	UKC..+H23..X	-	-

* Also available in 300 and X-Series (medium size) ** Also available in 300-Series

(1) For SP, 4 different installation frames available

NTN range available upon request.



Special bearings: square, cylindrical and hexagonal bore

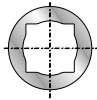

NTN	1AS..-(1)	3AS..-(1)
NBCA	DS..	DS..
NSK	W2..PPB../ GW2..PPB..	W2..PPB../ GW2..PPB..
INA	VK..KTT-B(-AH...)	-
Fafnir	W2..PPB../ GW2..PPB..	W2..PPB../ GW2..PPB..

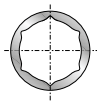

NTN	1AH..-..	2AH..-..
NBCA	HPC..	HPS..
NSK	..KRR..	..KRRB..
INA	-	SK...KRR-B
Fafnir	..KRR..	..KRRB..

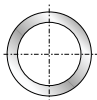

NTN	1AC..-(1)	3AC..-(1)
NBCA	DS..	DS..
NSK	W2..PPB../ GW2..PPB..	W2..PPB../ GW2..PPB..
Fafnir	W2..PPB../ GW2..PPB..	W2..PPB../ GW2..PPB..

(1) Other designs on request

Bearing insert with cylindrical outer ring



NTN	UCS2..D1**	UCS2..D1N	UELS2..D1**	UELS2..D1N	AELS2..NW3	AELS..D1NW3	ASS2..N	ASS2..D1N
SNR	-	CUC2	-	CEX2	CES2	-	CUS2	-
NSK	-	UCS2..D1N	-	UELS2..D1N	-	AELS..D1NW3	ASS2..N	ASS2..D1N
RHP	11..-..	11...CG	11...DEC	11...DECG	13...EC	13...ECG	13...-	-
KOYO/JTEKT	RB..	ER..	-	-	-	-	-	-
ASAHI	-	SER2..	-	-	KHR2..	-	-	-
INA	-	-	E..KRR	-	RAE..NPP NR	RA..NPP NR	-	-

** : Also available in 300-Series

Temperature



NTN	..HT2	..CT1
SNR	..T20	..T04
INA	..FA164	..FA101
SKF	..VA201	..VA201
ASAHI	..HR5	..CR2A
RHP	-	..HLT
NSK	..HT2	..CT1

Seals



NTN	..LLJ	-
SNR	..L3	..L4
INA	..KTT-B	-
SKF	-	..2RF
ASAHI	-	-
RHP	T...-	..GFS
NSK	..LLJ	-
KOYO/JTEKT	..L3	-

The interchanges are given for information only and you should check that the chosen product corresponds to your requirements. In case of doubt, please do not hesitate to contact us.

NTN range available upon request.

Interchange tables



Stainless steel self-aligning bearing units

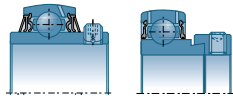

NTN	F-UCPM../LP03	-
SNR	SUCP	SESP
ASAHI	MUCP	-
DODGE	P2B-SCEZ	-
NTN	F-UCFM../LP03	-
SNR	SUCFL	SESFL
ASAHI	MUCFL	-
DODGE	F2B-SCEZ	-
SNR	SUCPA	SESPA
ASAHI	MUCPA	-

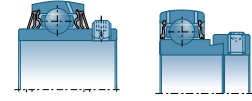

SNR	SUCF	SESF
ASAHI	MUCF	-
DODGE	F4B-SCEZ	-
SNR	SUCT	SEST
ASAHI	MUCT	-
SNR	SUCFBL	SESFBL
AMI	MUCFBL	-
DODGE	FB-SCEZ-SHSS	-



Thermoplastic self-aligning bearing units

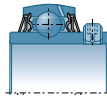

NTN	F-UCPR2../LP03**	
SNR	MUCPPL	
SKF	SYWK	
INA	SUCPP	
NSK-RHP	PNP..CR	
SNR	MUCTBL	
SKF	SYFWK	
INA	SUCPPA	
NSK-RHP	-	
NTN	F-UCFR2../LP03*	
SNR	MUCFPL	
SKF	FYWK	
INA	SUCPF	
NSK-RHP	PSF..CR	

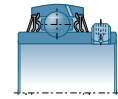

NTN	F-UCFLR2../LP03**	
SNR	MUCNFL	
SKF	FYTWK	
INA	SUCPFLL	
NSK-RHP	PSFT..CR	
SNR	MUCFBL	
SKF	FYAWK	
INA	-	
NSK-RHP	-	

*: black - **: white or black



Pressed steel self-aligning bearing units

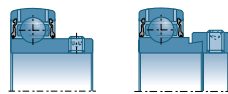

NTN	ASPP	AELPP..W3
SNR	USPP	ESPP
INA	PBY	PB
SKF	P..RM	P..FM
RHP	LPB..A	LPB..EC
ASAHI	BPP..-Z2	KHPP..-Z2
KOYO/JTEKT	SBPP	SAPP
SNR	USPFT	ESPFT
INA	RATRY	RATR
SKF	PFD..RM	PFD..FM
RHP	SLFT..A	SLFT..EC
ASAHI	BPFT	-

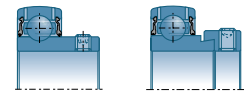
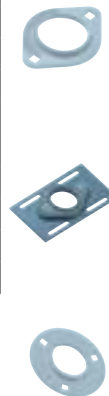

NTN	ASPFL	AELPFL
SNR	USPFL	ESPFL
INA	RATY	RAT
SKF	PFT..RM	PFT..FM
RHP	SLFL..A	SLFL..EC
NSK	ASPFL	AELPFL
ASAHI	BPFL	KHPFL
KOYO/JTEKT	SBPFL	SAPFL
SNR	USPFE	ESPFE
INA	-	MSTU
NTN	ASPF	AELPF..W3
SNR	USPF	ESPF
INA	RAY	RA
SKF	PF..RM	PF..FM
RHP	SLFE..A	SLFE..EC
NSK	ASPF	AELPF..W3
ASAHI	BPF	KHPF
KOYO/JTEKT	SBPF	SAPF

The interchanges are given for information only and you should check that the chosen product corresponds to your requirements. In case of doubt, please do not hesitate to contact us.

NTN range available upon request.

Bearing inserts

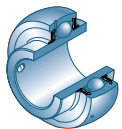
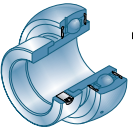
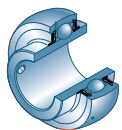
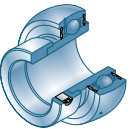
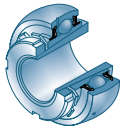
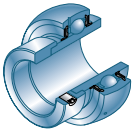
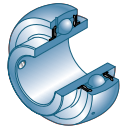

	Series 200	Series 300	X-Series
NTN	UC2..D1	UC3..D1	UCX..D1
SNR	UC2..G2	UC3..G2	UCX..G2
INA	GYE..-XL-KRR-B	-	-
SKF	YAR2..2F	-	-
RHP	10...-G	-	-
NSK	UC2..D1	UC3..D1	UCX..D1
ASAHI	UC2	UC3	UCX
KOYO/JTEKT	UC2	UC3	UCX
NTN	UEL2..D1W3	UEL3..D1W3	-
SNR	EX2..G2	EX3..G2	-
INA	GE..-XL-KRR-B	GNE..-XL-KRR-B	-
SKF	YEL2..-2F	-	-
RHP	10...-DECG	-	-
NSK	UEL2..D1W3	UEL3..D1W3	-
ASAHI	UG2..+ER	-	-
KOYO/JTEKT	NA2	-	-
NTN	UK2..D1;H23..X	UK3..D1;H23..X	UKX..D1;H23..X
SNR	UK2..G2H	UK3..G2H	-
SKF	YSA..-2FK, H23..	-	-
RHP	10..-KG, H23..	-	-
NSK	UK2..D1;H23..X	UK3..D1;H23..X	UKX..D1;H23..X
ASAHI	UK2..+H23..	UK3..+H23..	UKX..+H23..
KOYO/JTEKT	UK2..+H23..X	UK3..+H23..X	UKX..+H23..X
SNR	LK2..G2H	-	-
INA	GSH..-XL-2RSR-B	-	-
NTN	AS2..D1	-	-
SNR	US2..G2	-	-
INA	GAY..-XL-NPP-B	-	-
SKF	YAT2	-	-
RHP	12...-G	-	-
NSK	AS2..D1	-	-
ASAHI	B	-	-
KOYO/JTEKT	SB2	-	-
NTN	AEL2..D1W3	-	-
SNR	ES2..G2	-	-
INA	GRAE..-XL-NPP-B	-	-
SKF	YET2a a	-	-
RHP	12...-ECG	-	-
NSK	AEL2..D1W3	-	-
ASAHI	KH2..AE	-	-
KOYO/JTEKT	SA2	-	-
NTN	F-UC2..D1/LP03	-	-
SNR	SUC2	-	-
DODGE	SCEZ	-	-
ASAHI	MUC2	-	-
KOYO/JTEKT	UC2..S6	-	-
NTN	-	-	-
SNR	SES2	-	-
INA	SUG2	-	-
NTN	F-UC2..D1/LP03	-	-
SNR	-	-	-
SKF	YAR2..-2RF/HV	-	-
INA	GYE..-XL-KRR-B-VA	-	-
NSK-RHP	J10...-GCR	-	-
NTN	CS2..LLU	-	-
SNR	62..SEE	-	-
INA	2..-XL-NPP-B	-	-
SKF	17262..-2RS1	-	-
RHP	-	-	-
NSK	CS2..DDU	-	-
KOYO/JTEKT	CB2	-	-
FAG	2..-XL-NPP-B	-	-



Suitable for grey cast housings



Suitable for sheet metal housings



Suitable for stainless steel housings



Suitable for thermoplastic housings



SPLIT
PLUMMER
BLOCK
HOUSINGS

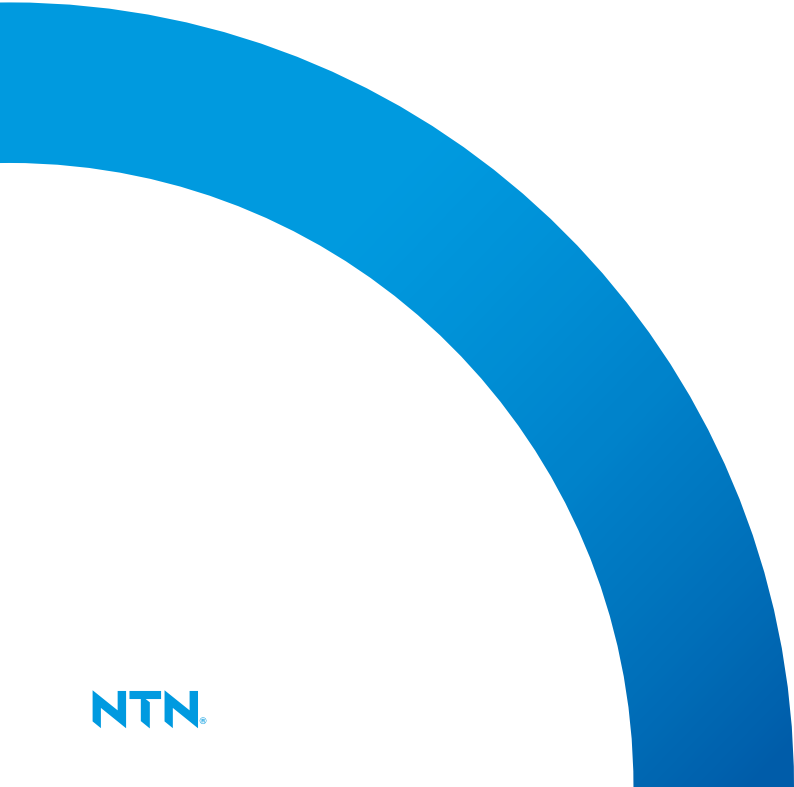

ALL INCLUSIVE - PERFORMANCE - INNOVATION

SNCD



LARGE PLUMMER BLOCK HOUSINGS

The SNCD large plummer block range has been developed by **NTN** for highly demanding industrial applications. Equipped with spherical roller bearings for a shaft diameter from 115 mm to 500 mm, the SNCD range is perfectly designed to bear heavy loads. Important features such as connectors for temperature and vibration monitoring are already included as standard just like machined stop edges and grease drain holes.

Thanks to the use of heavy-duty ductile iron and the innovative design concept, the SNCD split plummer block housings are capable of reducing the stress level of the bearing and increasing its service life.

All inclusive as standard



Brand of **NTN corporation**

SNR - SNCD housings

SNCD housings are made for support spherical roller bearings with tapered or cylindrical bore. The split housings are available for fixed or floating bearing arrangement and can support bearings with shaft diameters from 115 to 500 mm.



Benefits

Interchangeable

- Full interchangeable with grey cast
- Compatible with market standards

More than 400 arrangements possible

- Suitable for 222, 223, 230 and 231 SRB series
- Cylindrical bores or adapter sleeves solutions
- Metric and imperial dimensions

One global supplier

- Housings, bearings and accessories
- Technical assistance (study and recommendations)
- Service engineering

Technical features

All inclusive

- 1 Machined stop edges
- 2 Housing positioning mounting bores
- 3 Grease nipple connections (grease nipple attached)
- 4 Grease drain holes
- 5 Machined surface for condition monitoring systems
- 6 Ready to use connection for temperature sensor
- 7 Ready to use connection for vibration sensor

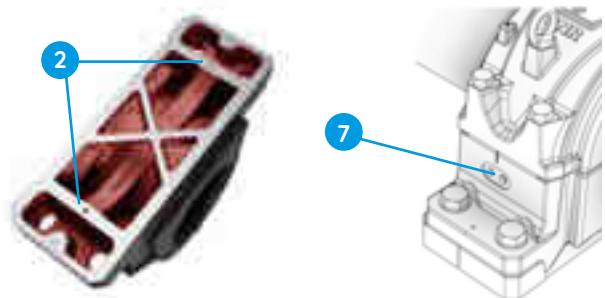
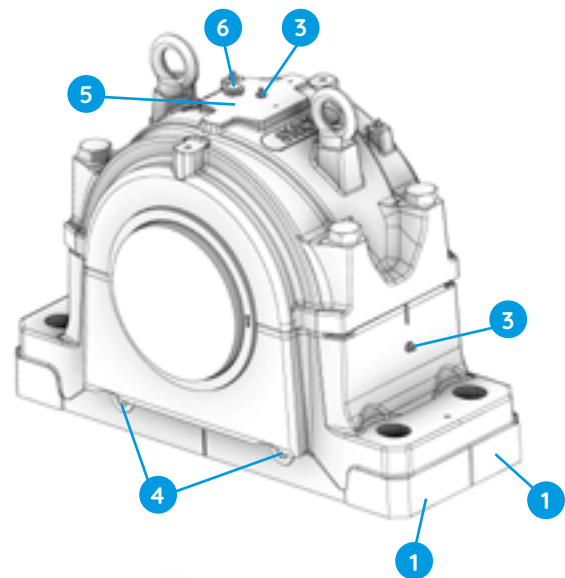

SNR - SNC / SNCD500



- SN housing according to ISO113-2010 for bearings with a cylindrical or tapered bore
- High stiffness and stability due to special design elements
- Reduced stress in the bearing
- Extended service life and prolonged service intervals
- For shaft diameters from 20 mm to 140 mm
- Housing material: cast iron with flake graphite and/or spheroidal graphite (SNCD500)
- 5 different seal arrangements for a wide range of applications
- User-friendly design features for ease of service and rapid installation



Also available as heavy duty version from spheroidal graphite cast iron and with different mounting bore pattern

Sealing

SC...DS

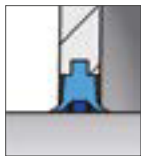

Double lip seal
Multipurpose seal

SC...FS / SC...FSS*



Felt strip seal
Well suited for higher rotational shaft speed

SC...SV



V-Ring seal
Reduced friction

Optional V-ring for better sealing effect in downtimes



*With steel retainer

SC...LA



Labyrinth seal
Well suited for high temperature applications

SC...TA



Taconite seal
Multiple seal for harsh environments

Multi-market kits

66 kits available in "normal clearance" or "C3 internal clearance" for shaft diameters from 35 mm to 90 mm.



ALL-IN-ONE,
MAKE YOUR
LIFE EASIER

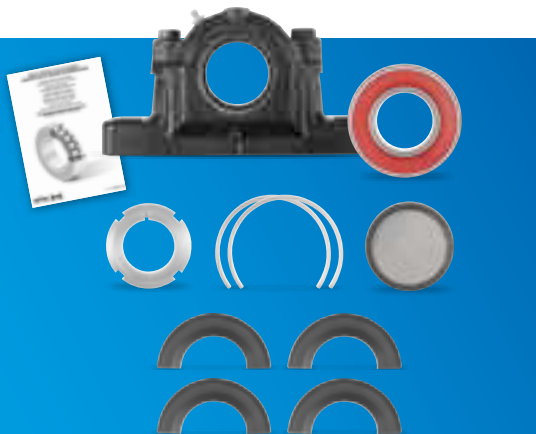

SNC HOUSING SEALED KIT

including a sealed spherical roller bearing and specific accessories



SNC HOUSING STANDARD KIT

including an open spherical roller bearing with specific accessories and a monopoint greaser

For more
information,
have a look
at page 68!





CMD
CUSTOMISED
MODULES



SNR - CMD customised modules



Ready to be installed
in your specific application

- The **NTN** team develops individual mounted units together with you according to your requirements
- An optimal design for a robust and sustainable system solution
- Taking into account your application parameters, operational reliability and costs, we define the necessary materials and all components

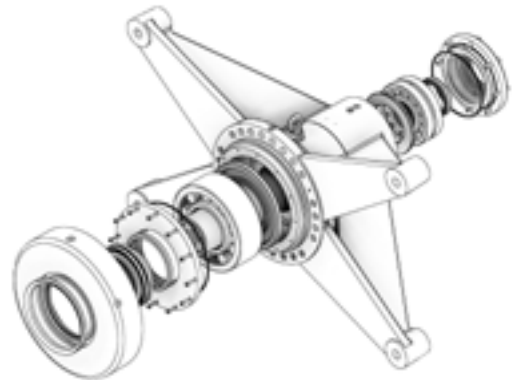

Example: ready-to-install customised module for industrial washing machine

Individual complete solutions
for maximum performance

- **Reduce your effort** and rely on system solutions
- **Optimise and complement your team** with our experts



- **Choose a safe and easy installation** thanks to individual and ready-to-install mounted units
- **Operational safety and warranty.** We guarantee security through decades of experience: application knowledge and production know-how in the international network

Benefits

- One point of contact
- Your application optimised through modifications
- Our quality



Contact us and we will develop your individual solution together! cmd@ntn-snr.de
Or use our inquiry form



**NTN, your
engineering
partner**

NTN

○ LINEAR MOTION



Brand of NTN corporation





CUSTOMISED LINEAR AXES



Brand of NTN corporation



SNR - Customised linear axes

Our company produces one of the broadest product ranges of linear axes on the market.

Benefits

Cost reduction through reduced design and assembly effort

- Simplification of logistical processing
- Avoidance of assembly errors

Why linear axes?

- Complete systems including guiding and drive system
- Partially closed - optimal protection against dirt
- Reduced effort on the customer side (design, purchasing, assembly)

Range overview



COMPACT AXIS
AXC



COMPACT AXIS
AXF



PARALLEL AXIS
AXDL



LINEAR TABLES
AXLT



PRECISION AXIS
AXBG



SYSTEM PROGRAM
AXS



LINEAR MOTOR
AXLM



ACCESSORIES and SPECIAL
SOLUTIONS
AX-AC-...

Good to know!

There is no uniform standard that regulates the dimensions of linear axes and the determination of their load ratings.

When building linear axes, **NTN** complies with the EU Machinery Directive and the associated standards.

Guiding systems



LINEAR GUIDES



HIGHER
LOAD RATINGS



TRACK ROLLER
GUIDES



MAX. SPEED
15 M/S

Drive systems



TOOTHED BELT



SCREW DRIVE



RACK AND PINION



LINEAR MOTOR

Advantages

Linear Axis with toothed belt drive:

- Integrated drive + deflection system
- Best ratio of stroke to total length

Rack and pinion drive:

- Several tables can be moved asynchronously

Systems for every branch

- Can be combined with the entire portfolio
- Including connecting elements, energy chains, switches etc.

Telescopic Axis

- Versions for horizontal and vertical use



Standard &
special solutions
for mechanical
engineering



STANDARD LINEAR AXIS

BUILD YOUR OWN SOLUTION

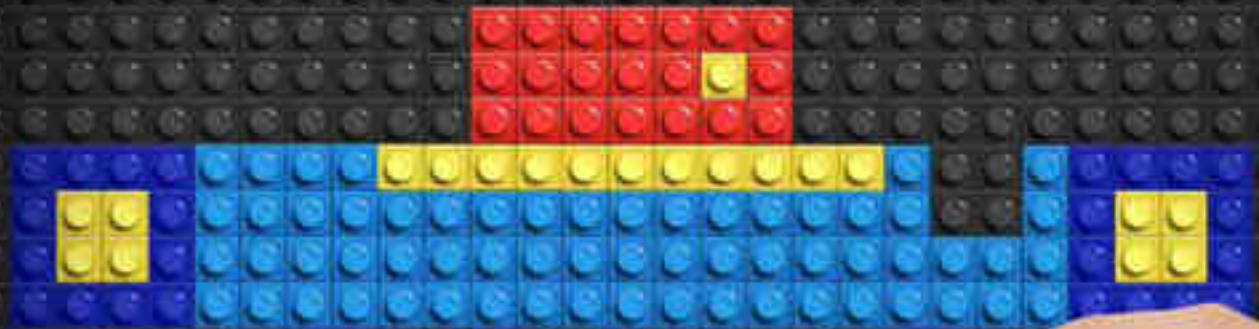

STANDARDISED LINEAR AXIS

AXE linear axes are the perfect combination of technical expertise and practical solutions for customer needs.

Thanks to an online configurator based on standard component definition, high quality AXE module design is immediately and easily accessible for all.

Production and logistics managed in Germany guarantee an outstanding delivery lead time for these linear axes.

Our offer includes all the elements required to finalise safe implementation for the customer.

AXE, thousands of available combinations to build your own solution.



Brand of NTN corporation

SNR - Standard linear axis

With the standard AXE Linear Axis, NTN starts the digital selection of linear axes with new internal processes.

Benefits

- Minimal production time thanks to the modular structure
- All accessories are available as assembling groups

Why AXE?

- Shortest delivery time (1-2 weeks ex works)
- Standard Multi-Axis system including all connecting elements, energy chains and switches
- Reduced effort on the customer side (design, purchasing, assembly)

Range overview



Linear Axis with toothed belt drive
AXE-Z



Standard Multi-Axis systems



Linear Axis with toothed belt / Ω drive
AXE-A



Standard accessories

Good to know!

When building linear axes, NTN complies with the EU Machinery Directive and the associated standards.

Interesting industries for linear axes: packaging industry, material handling, automated production and assembly lines, etc..

Guiding systems



LINEAR GUIDES



HIGH LOAD RATINGS



**HIGH TOLERANCE
COMPENSATION CAPACITY**



LOW MAINTENANCE

Drive systems



TOOTHED BELT DRIVE



HIGH DYNAMIC



GREAT LENGTH



LOW WEAR



Advantages

Online configuration

- Inclusive gearbox, drive adaption, switches...
- Part list generation for the selected product

Shortest delivery time

- Standardisation of all components
- Modular design

Made in Germany

- Single axes
- Standard multi-axe systems

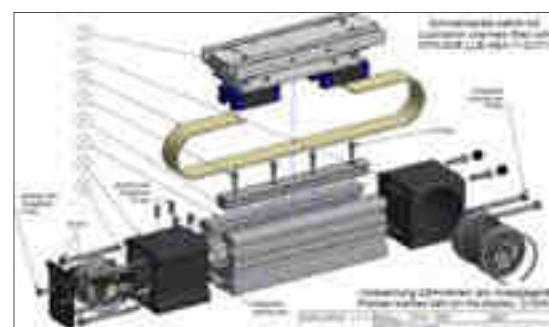

**Standard
solutions
for mechanical
engineering**



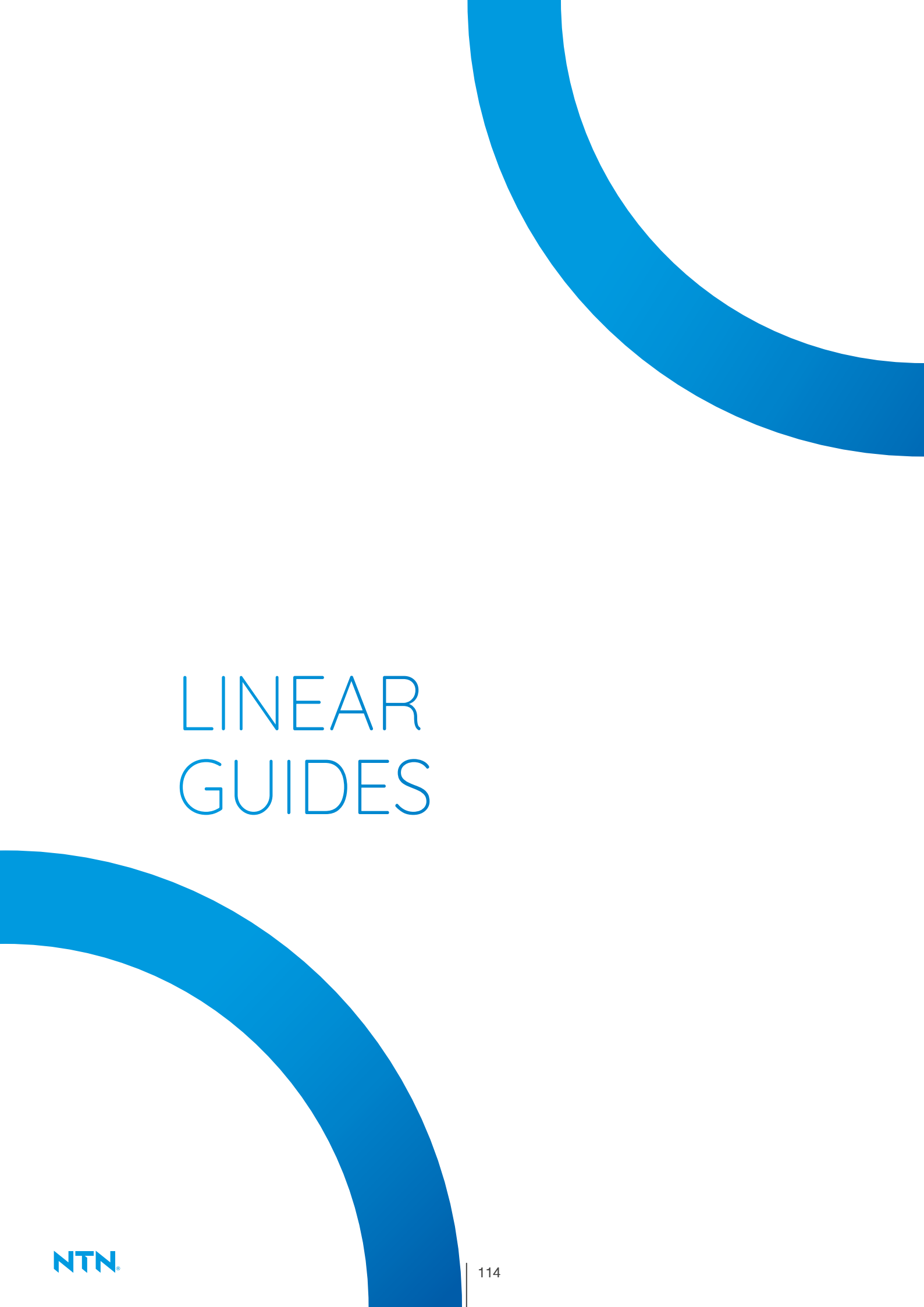

LINEAR GUIDES



Brand of NTN corporation

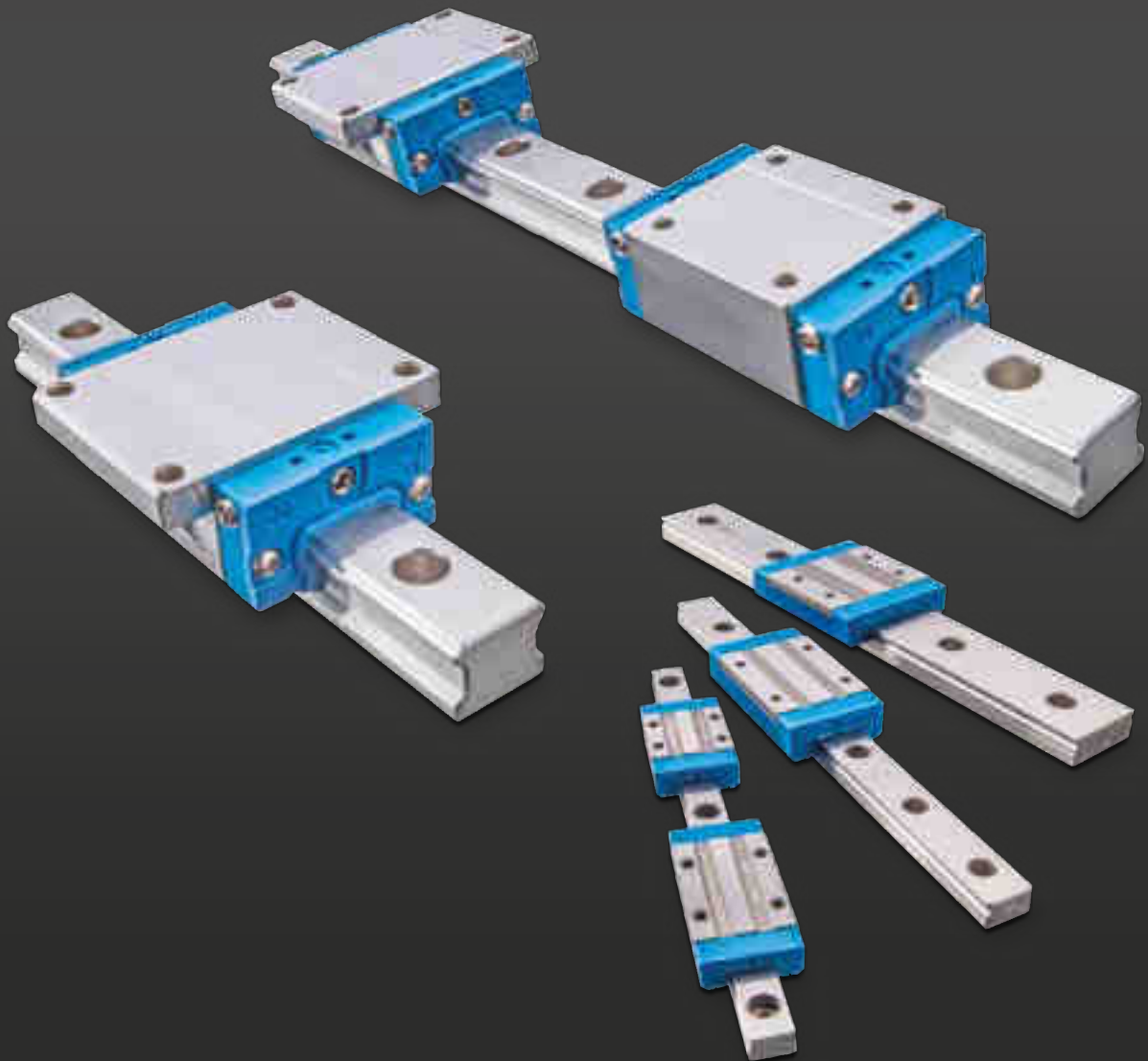

SNR - Linear guides

Two technologies - one geometry - one rail per size (modular system).
According to DIN ISO 12090.

**LGBC...
(BALL CHAIN TYPE)**

DF CONFIGURATION

**LGBX...
(CONVENTIONAL TYPE)**

Lubrication options

- Lateral lubrication channels closed with set screws = simply switch between the lubrication points
- Lubrication option from above as standard
- Fixable adapters for high carriage types



Jointed rail

The rail joint is always marked with a "J" (J = Jointed Rail!)

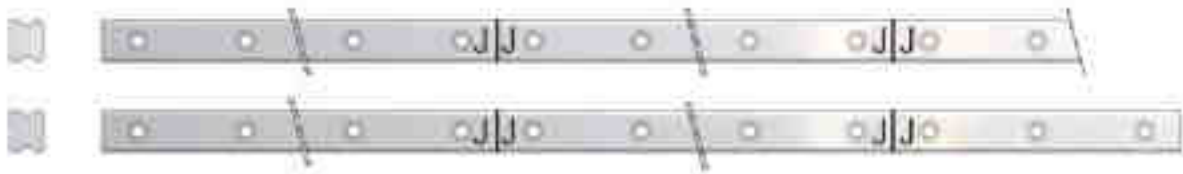

- No assembly sequence - error prevention!
- Simply replace in case of damage - measure the length, done!
- Easy to extend

Extension of interchangeability

Separate delivery of carriage and rail up to precision class "P" possible!

**One step ahead
with quality for
over 30 years**

Maximum lengths

- Standard rails LGBR 15...55 ~ 4.000 mm
- Miniature rails
 - LGMR, narrow 09...15 ~ 2.000 mm
 - LGMW, wide 09...15 ~ 2.000 mm
- Miniature rails LGMR 07 ~ 450 mm

Accessories

- Clamping elements
- Central lubrication
- Brass caps
- Cover strip
- etc.



* available only in certain territories

Extremely powerful ball chain



Spacer ball for smooth ball circulation



Online configuration





BALL SCREWS

The new range of LINEAR MOTION BALL SCREWS



Handle motion with precision

SNR ball screws are high-quality products that are among the most important drive elements for mechanical engineering in linear technology. Our new whirled ball screws offer you an optimal price-performance ratio and meet the highest requirements in terms of precision. Many screw diameters, pitches and nut designs offer a high degree of flexibility for your application.

Ball screws are precision products designed to meet your needs.



Brand of **NTN corporation**

SNR - Ball screws

We offer all manufacturing technologies:

Rolling, whirling, grinding



Tolerance classes

- Transport Ball Screws (T10, **T7**, **T5**, T3)
- Positioning Ball Screws (**P5**, P3)
Blue marking is our standard

Preload

To increase the rigidity:

Z0 = axial clearance

Z1 = without axial clearance, without preload

Z2 = light preload (~ 3% Ca)

Z3 = medium preload (~ 5% Ca)

Z4 = high preload (~7% Ca)

Higher preload normally with double nuts!

**SNR Ball
Screws: Easy to
work with!**

Fixed and floating bearing units



European range:

Type BSTK / BSTL



Asian range:

Type BK / EK / FK / BF / EF / FF

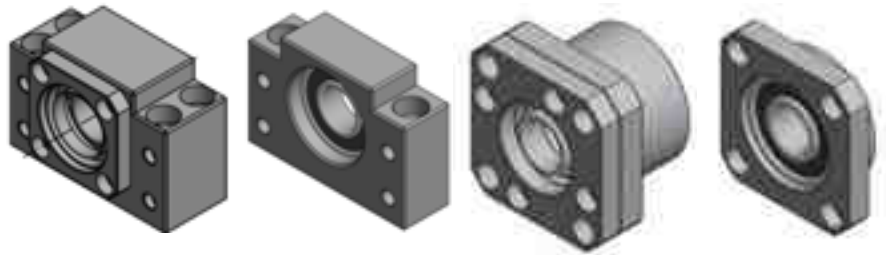

Lubrication

There is no lifetime lubrication for ball screws!

In general, the same greases should be used as for Linear Guides + Bearings.

Standard &
special solutions
for mechanical
engineering





BALL BUSHINGS



Brand of NTN corporation



SNR - Ball bushings

Extensive support from NTN.

ISO standard & JIS standard.

One of the widest product ranges on the market.

Application

- General engineering
- Wood working industry
- Fitness equipment
- Packaging machines
- Medical equipment



Why ball bushings?

- Cost-effective implementation of linear movements
- Self-supporting guide, which is clamped at the ends
- Minimised maintenance effort due to low lubricant consumption
- Low friction
- Interchangeable: diameter, length and grooves are standard

Which ball bushings?

STANDARD BALL BUSHINGS

- Same dimensions and tolerances as super ball bushings
- $v_{max.} = 1,5m/s$
- Damp or wet environment
- Suitable for vacuum applications
- High temperature versions

SUPER BALL BUSHINGS

- Same dimensions and tolerances as standard ball bushings
- $v_{max.} = 3m/s$
- Misalignment compensation up to $\pm 0,5^\circ$
- Higher load ratings
- Smooth running performance
- Same loads ▶ smaller size
- Reduced system costs!

**Ball bushings
for simple and
inexpensive
implementation
of linear
movements.**

Widest product ranges

One of the widest product ranges on the market!



	ISO BALL BUSHINGS		BALL SLEEVES		JIS BALL BUSHINGS
Closed		Closed		Closed	
Open		Open			
Adjustable					
With flange					
Tandem					
Tandem with flange					
Tandem with middle flange					

In addition:
Support rails, shaft supports, clamping elements etc.
Stainless versions for high temperatures

Linear units

	SINGLE		TANDEM		QUATTRO
Closed		Closed		Closed	
Open		Open		Open	
Open adjustable		Open adjustable			

With standard ball bushings and super ball bushings available.

Trust & support
for common
success!

○ TECHNICAL SERVICES



SERVICES, OUR OFFER

Because your industrial performance is essential to your future success, **NTN** is committed to increasing the longevity of your equipment while reducing your maintenance costs through a range of services.

Our experts are at your side to offer you assistance and training services, as well as tools and lubrication solutions to maximise the life of your bearings.



Brand of **NTN** corporation



MAINTENANCE TOOLS



SmartTEMP Induction Heater

Looking to increase your machine's reliability in order to reduce your operational costs? Discover the SmartTEMP by **SNR**, an innovative induction heater range. With its intelligent heating modes, it maintains the integrity of your sprockets and bearings, to ensure optimal mounting, necessary to achieve your goals.

The premium heating solution for all your mechanical components.



Brand of NTN corporation

SNR - Induction heaters: SmartTemp

The only tool to control the heating of bearings, sprockets, spacer rings...



Why this new generation of heater is the best on the market?

- **LOW OPERATING COSTS**

Heating bearings and sprockets properly before assembling is crucial to ensure a longer service life of your equipment

- **EFFICIENT**

Best solution on the market to heat mechanical parts with less energy consumption 24 hours a day, 7 days a week, 365 days a year

- **EASY TO USE**

Thanks to its innovative touch screen, set up, monitoring, data extraction are extremely simple

Technical features

	SmartTEMP S	SmartTEMP M	SmartTEMP L	SmartTEMP XL & XL PIVOT	SmartTEMP XXL	SmartTEMP XXXL
Max. weight of workpiece (bearing, sprocket, ring...) (kg)	50	100	200	400	800	1600
Min. bore diameter (mm)	10	10	20	30	40	85
Max. outer diameter (mm)	400	500	600	1000	1500	2000
Power rating (kVa)	3	3.7	8	12.8	25.2	40
Facility power *	230V/13A	230V/16A	400V/20A	400V/32A	400V/63A	400V/100A
Temperature setting range	+40°C to 240°C	+40°C to 240°C	+40°C to 240°C	+40°C to 240°C	+40°C to 240°C	+40°C to 240°C
Included	<ul style="list-style-type: none"> • 3 yokes: 14x14x200 mm, 25x24x200 mm, 40x38x200 mm • 1 temperature sensor • 1 pair of gloves 	<ul style="list-style-type: none"> • 1 pivoting yoke: 50x48x280 mm • 1 temperature sensor • 1 pair of gloves 	<ul style="list-style-type: none"> • 1 pivoting yoke: 70x70x350 mm • 2 temperature sensors • 1 pair of gloves 	<ul style="list-style-type: none"> • 1 yoke (pivoting according to the model): 80x80x490 mm • 2 temperature sensors • 1 pair of gloves 	<ul style="list-style-type: none"> • 1 yoke: 100x100x750 mm • 2 temperature sensors • 1 pair of gloves 	<ul style="list-style-type: none"> • 1 yoke: 150x150x1080 mm • 2 temperature sensors • 1 pair of gloves

* Other voltage on demand

SNR - Hydraulic nuts

Simple and safe assembly / disassembly of rolling bearings with a taper bore.

Precise and reliable adjustment of the radial internal clearance of rolling bearings with a taper bore.

Why is this hydraulic nut the best on the market?

- Unique with its patented Back & Forth system (piston moves back automatically)
- Special surface treatment to protect against corrosion
- Knurling on the outside diameter for easy and safe handling
- The “emergency stop function” prevents the piston from falling out
- Extensive standard range in stock



Applications

- Mines and quarries
- Paper mill
- Wind mill
- Cement factories
- Railway
- Steel industry
- Construction machinery
- Heavy machinery industry and much more

Interchange

Thread	Sizes	Sizes	Sizes	Sizes	Weight
metric	metric	metric	metric	metric	kg
G	SNR	SKF	FAG new	FAG old	approx.
M 50x1.5	HMV 10 EBF	HMV 10E	HYDNUT50	RKP50	2.9
M 55x2	HMV 11 EBF	HMV 11E	HYDNUT55	RKP55	3.0

The interchanges are given for information only and you should check that the chosen product corresponds to your requirements. In case of doubt, please do not hesitate to contact us.

SNR - Other maintenance tools

SNR brand offer also includes a large range of mounting and dismounting tools such as fitting tools, bearing pullers, wrenches...

Bearing pullers



Cold mounting case



Hydraulic pump





LUBRICATION SOLUTIONS

SNR - Single point lubricators



READY – DRIVE – SMART: The ultimate weapon for automatic lubrication.



READY booster

Economical and reliable

- Significant savings due to the flexibility of use (1-12 months and stoppable)
- Suitable for tight and restricted areas (Ex proof)
- Ready to use: no assembly and no tools required
- Only one lubricator for all of your applications: inside and outside (-20°C up to 60°C)
- IP68 protection class: reliable lubrication even in extremely moist and dusty areas

Due to its compact size, the Ready Booster can be used in various applications: bearings, plummer block, chains, electrical motors, fans, pumps, conveyors, etc.

DRIVE booster

Powerful and precise

- Independent with its powerful battery pack
- Powerful: suitable for remote greasing
- Precise: discharge period from 1 to 12 months
- Easy-to-use refill cartridge

For extremely accurate lubrication, independent of temperature and ambient pressure, extremely reliable in use.



SMART booster

Effective and technical

- Accurate, ergonomic
- Adjustable to the nearest month on the LCD screen
- Constant flow, independent of ambient temperature
- Recyclable: re-usable control unit
- Suitable for use in explosive areas

Effective, precise, flexible lubrication for applications subject to wide variations in temperature or situated in explosive environments.

Grease options



UNIVERSAL +

HEAVY DUTY +

VIB

HIGH TEMP MP

FOOD

FOOD CHAIN OIL

CHAIN OIL

DESCRIPTION

General purpose grease for industrial use.	Suitable for very high loads, compatible with many applications, intended for arduous applications.	Parts subject to extensive vibrations or impact. For high-load applications in humid environments.	This grease is ideal for long-term lubrication at high temperatures up to +180°C.	Multi-purpose grease for the food and pharmaceutical industries. Complies with NSF-H1 recommendations.	Food-grade oil for chains designed for the food-processing and pharmaceutical industry. Complying with NSF-H1 recommendations.	Synthetic oils for high temperature chains.
--	---	--	---	--	--	---

FOR YOUR APPLICATION

	0 limited suitability + suitable ++ very suitable	conveyors	electric motors	pumps	blowers / fans
READY	+	+	+	+	+
SMART	0	+	0	0	+
DRIVE	++	++	++	++	++



SNR - Multipoint lubrication solution



POLIPUMP: low cost and easy to implement centralised greasing.

Benefits

- **A cost-effective choice**
- **An economical and effective solution**
Possibility of lubricating 1 to 35 points with the grease of your choice up to a distance of 20 meters
- **Environmentally friendly and easy to implement**
No technical skills are required for the installation of central lubrication system. Ready to use and easy to refill, this environmentally friendly pump will continue to help reducing your waste

Applications

- **Industry**
POLIPUMP can be used for the lubrication of bearings, plain bearings, open gears, chains, ball screws, linear guidance, etc.
- **Vehicles and chassis (agricultural, building, trucks...)**
A specific version of POLIPUMP has been designed for applications on earth moving equipment, agricultural machinery, trucks, etc.



Lubrication range

SNR BRAND OFFERS A SELECTION OF PROFESSIONAL GREASES THAT SHOULD MEET MOST OF YOUR NEEDS.



SERVICES

Training / e-learning

E-learning program

9 modules and 9 quizzes to reinforce your knowledge about bearings.
Learn when and where you wish thanks to our E-Learning platform!



Seminars

With our tailor-made trainings, we respond precisely to your requirements when it comes to the safety of your staff and machines during handling, installation, removal, lubrication of various rolling bearings or linear products.

- Seminar program
- Standard seminars / tailor-made seminars
- At one of our training centres, at your location or online (e.g. web seminars)

Technical support and commissioning maintenance

- Assessment of current situations
- Supervising, assembly / disassembly support
- Optimisation of the assembly process
- Support to use new tools
- Assembly method development for specific problems



Bearing diagnosis

- Initial assessment
- Neutral reports



Advice on lubrication

- Lubrication systems (single point, centralised pumps)
- Lubricants
- Lubrication intervals and quantities



Tool rental

- HMV (hydraulic nuts)
- Induction heaters





ADDITIONAL TECHNICAL PRODUCTS



Constant velocity joints for industrial applications

From **NTN** technical knowledge

- Know-how of the second largest manufacturer on the market
- Jerk-free and vibration-free solutions, even for large angles
- Available as standard as 3-ball joint shafts (TBJ) and as 6-ball joints (BJ)
- Examples of applications: machine tools, glass industry, industrial washing machines, loading machines, steel and iron industry etc.



For more information, please contact us.



NTN

Make the world **NAMERAKA**

This document is the exclusive property of NTN Europe.

Any total or partial reproduction hereof without the prior consent of NTN Europe is strictly prohibited. Legal action may be brought against anyone breaching the terms of this paragraph.

NTN Europe shall not be held liable for any errors or omissions that may have crept into this document despite the care taken in drafting it. Due to our policy of continuous research and development, we reserve the right to make changes without notice to all or part of the products and specifications mentioned in this document.

© NTN Europe, international copyright 2021.



DOC_LHANDBOOK_CAT3_GBa - Conception et réalisation - Service publicité NTN © 03/2023 - Photos : © Pedro Studio Photos - Shutterstock