

NTN®

Precision Rolling Bearings

CAT.No.2260-10/E

NTN®



NTN Precision Rolling Bearings

Appendix

15. Appendix Table 364

Appendix

NTN Products

14. Cam Followers for Pallet Changer 360

NTN Products

Ball Screw Support Bearings

13. Ball Screw Support Bearings 323

Ball Screw Support Bearings

Main Spindle Bearings

9. Angular Contact Ball Bearings for Radial Loads 85
10. Cylindrical Roller Bearing 251
11. Angular Contact Ball Bearings for Axial Loads 287
12. Tapered Roller Bearings 315

Main Spindle Bearings

Technical Data

1. Classification of Precision Rolling Bearings for Machine Tools 2
2. Bearing Selection and Shaft & Housing Design 6
3. Load Rating and Life 21
4. Allowable Speed 29
5. Bearing Arrangements and Structures of Bearings for Main Spindles 30
6. Handling of Bearings 37
7. Lubrication of Bearings 62
8. Precision Bearing Technologies 74

Technical Data

Precision Rolling Bearings

Page

TECHNICAL DATA CONTENTS

1. Classification of Precision Rolling Bearings for Machine Tools	2-5
1.1 Main spindle bearings	2
1.2 Ball screw support bearings	5
2. Bearing Selection and Shaft & Housing Design	6-20
2.1 Bearing selection	6
2.2 Bearing accuracy	8
2.3 Bearings and rigidity	13
2.4 Designing shaft and housing	19
3. Load Rating and Life	21-28
3.1 Bearing life	21
3.2 Static load rating and allowable axial load	27
4. Allowable Speed	29
5. Bearing Arrangements and Structures of Bearings for Main Spindles	30-36
5.1 Bearing arrangement for main spindles	30
5.2 Bearing selection based on bearing arrangement for main spindle	32
5.3 Adjustable preload bearing unit	34
5.4 Bearing jacket cooling system	36
6. Handling of Bearings	37-61
6.1 Cleaning and filling with grease	37
6.2 Mounting	40
6.3 Tightening of inner ring	43
6.4 Elastic deformation of spacer by tightening force	45
6.5 Front cover drive-up	47
6.6 Checking axial rigidity	48
6.7 Clearance adjustment for cylindrical roller bearing	48
6.8 Tapered bore cylindrical roller bearing and main spindle taper angle	56
6.9 Handling precautions	58
6.10 Bearing storage	58
6.11 Bearing installation	60
6.12 Running-in operation for main spindle bearing	61
7. Lubrication of Bearings	62-73
7.1 Grease lubrication	64
7.2 Air-oil lubrication	66
7.3 Jet lubrication	73
8. Precision Bearing Technologies	74-82
8.1 ULTAGE™ series precision bearings for machine tool main spindles	74
8.2 Material and surface modification	75
8.3 Environmentally conscious technology	77

According to the basic policy of **NTN** corporation, we do not export products or techniques that are regulated by foreign exchange rates or that violate foreign trade laws. For classification of products specified in this catalog, please contact our branch business offices.

In addition, the accuracy of this catalog has been confirmed; however, please note that we do not take any responsibility or liability for any erroneous descriptions or omissions.







1. Classification of Precision Rolling Bearings for Machine Tools

1.1 Main spindle bearings

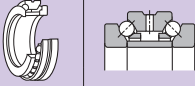

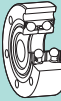



Table 1 Types of precision rolling bearings for machine tools

Bearing type	Cross section	Bearing type	Bearing bore mm	Contact angle	Remarks	Page	
Angular contact ball bearing	Standard	78C	φ25-φ170	15°	<ul style="list-style-type: none"> ● A bearing type code containing a suffix U means an ULTAGE series bearing. Optimized interior structure and resin cage help positively inhibit temperature rise (applicable to 79 and 70 types with bore diameter of 10 to 130 mm). ● Bearings with prefix 5S have ceramic balls. 	126	
		79 (U), 5S-79 (U)	φ10-φ170	15°, 25°, 30°		153	
		70 (U), 5S-70 (U)	φ10-φ200	15°, 25°, 30°			
		72C	φ10-φ130	15°			
	High speed	ULTAGE	2LA-HSE9U 5S-2LA-HSE9U	φ50-φ170	15°, 20°, 25°	<ul style="list-style-type: none"> ● ULTAGE series ● Use of special material and introduction of surface modification contribute to much improved wear resistance and anti-seizure property. ● Optimized specifications for the interior structure lead to higher speed, rigidity and reliability. ● Bearings with prefix 5S have ceramic balls. 	154
			2LA-HSE0 5S-2LA-HSE0				177
	Ultra high speed	ULTAGE	5S-2LA-HSF0	φ50-φ100	25°	<ul style="list-style-type: none"> ● ULTAGE series ● Maintaining the advantages of HSE type, this type has small diameter ceramic balls to achieve higher speed and limited heat buildup. ● Bearings with prefix 5S have ceramic balls. 	178
							179
	Eco-friendly	ULTAGE	5S-2LA-HSL9U	φ50-φ170	20°, 25°	<ul style="list-style-type: none"> ● ULTAGE series ● These bearings are identical to the HSE and HSF types except in that they are air-oil lubrication designs that have an eco-friendly nozzle. ● Featuring lower noise, reduced air and oil consumption, they positively improve operating environments and reduce energy consumption. ● Bearings with prefix 5S have ceramic balls. 	180
			5S-2LA-HSL0				189
			5S-2LA-HSFLO				φ50-φ100
	HSE with Lubrication hole	ULTAGE	5S-2LA-HSEW9U	φ50-φ100	20°, 25°	<ul style="list-style-type: none"> ● ULTAGE series ● High speed angular contact ball bearings with lubrication hole on outer ring, designed especially for air-oil lubrication based on HSE type. These bearings have an effect on compact design and high rigidity of spindle. Air flow rate and oil consumption can be reduced. ● Bearings with prefix 5S have ceramic balls. 	190
5S-2LA-HSEW0			197				
Standard	ULTAGE	79 LLB 5S-79 LLB	φ10-φ50	15°, 25°	<ul style="list-style-type: none"> ● ULTAGE series ● Featuring a two-side non-contact seal design and a special grease, these bearings are a dedicated grease lubricated type that has achieved limited heat buildup through optimization of the interior structure. ● Bearings with prefix 5S have ceramic balls. 	198	
		70 LLB 5S-70 LLB				213	
High speed	ULTAGE	2LA-BNS9 LLB 5S-2LA-BNS9 LLB	φ45-φ100	15°, 20°, 25°	<ul style="list-style-type: none"> ● ULTAGE series ● Maintaining the advantages of HSE type, this dedicated grease lubricated type has an improved interior design (grease reservoir, both -side non-contact seal and special grease) to extend grease life. ● Bearings with prefix 5S have ceramic balls. 	214	
		2LA-BNS0 LLB 5S-2LA-BNS0 LLB				237	
Standard	ULTAGE	BNT9 5S-BNT9	φ10-φ65	15°	<ul style="list-style-type: none"> ● Angular contact ball bearings for grinding machines/motors. ● All variants are flush ground. ● Bearings with prefix 5S have ceramic balls. 	238	
		BNT0 5S-BNT0	φ10-φ70			249	
		BNT2 5S-BNT2	φ10-φ80				

Bearing type	Cross section	Bearing type	Bearing bore mm	Contact angle	Remarks	Page
Double-row cylindrical roller bearing	ULTAGE	NN49 (K)	φ100-φ320	—	<ul style="list-style-type: none"> ● The bearing clearance can be either interchangeable radial internal clearance or non-interchangeable radial internal clearance. ● A variant (K) is available with a tapered bore to accommodate a tapered shaft. ● A bearing type code containing a suffix T6 means an ULTAGE series bearing. Optimized interior structure and resin cage help high speed and positively inhibit temperature rise (applicable to NN30 types with bore diameter of 65 to 130 mm). 	270
		NN30 (K) NN30HS (K)	φ25-φ60 φ150-φ460			275
		NN30HST6 (K) NN30HSRT6 (K)	φ65-φ140			
Single-row cylindrical roller bearing	ULTAGE	NNU49 (K)	φ100-φ500	—	<ul style="list-style-type: none"> ● The boundary dimensions of the N10HS(K) high speed single-row cylindrical roller bearing are the same as those of the N10(K). Only the bearing clearance is non-interchangeable. ● A ceramic-roller-type (5S-N10) is available on request. ● ULTAGE series ● Optimized internal design allows higher speed and results in lower temperature rise. ● The cage is made of a special resin to cope with a high speed operation. ● The allowable maximum speed is higher than that of the conventional high speed cylindrical roller bearing N10HS(K). 	276
		N10HS (K)	φ30-φ160			279
		N10HSRT6 (K)	φ55-φ100			280
Eco-friendly	ULTAGE	N10HSLT6 (K)	φ55-φ100	—	<ul style="list-style-type: none"> ● ULTAGE series ● This is a dedicated air-oil lubricated type identical to the N10HSR(K) type except in that it incorporates an eco-friendly nozzle. ● Still maintaining the high speed performance of the N10HSR(K) type, this type boasts lower noise, reduced air and oil consumption, and positively improves operating environments and reduces energy consumption. 	282
			283			
Taper gauge	Ring gauge	Plug gauge TA	φ30-φ160	—	<ul style="list-style-type: none"> ● Taper gauge for N10-HS(K) single-row cylindrical roller bearing and NN30(K) double-row cylindrical roller bearing. 	284
		Ring gauge TB	φ30-φ160			
Taper gauge		SB	φ35-φ160	—	<ul style="list-style-type: none"> ● Mounted internal clearance adjustment gauge for N10-HSK(K), N10-HSR(K) single-row cylindrical roller bearing and NN30(K), NN30HS(K) double-row cylindrical roller bearing. 	285
Mounted internal clearance adjustment gauge		Adjustable preload bearing unit	—	—	<ul style="list-style-type: none"> ● Fixed position adjustable preload bearing unit. ● Incorporation of an adjustable preload sleeve and a duplex angular contact ball bearing allows the user to adjust the preload of an angular contact ball bearing in a wider range from a light preload to a heavy preload. ● Fixed position preload leads to a greater rigidity. 	—
Adjustable preload bearing unit						

Bearing type	Cross section	Bearing type	Bearing bore mm	Contact angle	Remarks	Page
 <p>Double-direction angular contact thrust ball bearing</p>		5629 (M)	Small-size φ100–φ320 Large-size (M) φ104–φ330	60°	<ul style="list-style-type: none"> The small bearing is used on a cylinder bore or smaller-diameter side of a tapered bore of the NNU49, NN49 or NN30 double-row cylindrical roller bearing; the large bearing (suffix M) is used on the large hole side of a tapered bore. 	298 301
		5620 (M)	Small-size φ25–φ320 Large-size (M) φ27–φ330			
 <p>Angular contact ball bearing for axial load</p>	 <p>ULTAGE</p>	HTA9U	φ100–φ320	30°, 40°	<ul style="list-style-type: none"> ULTAGE series HTA9UDB type bearings are fully compatible with 5629 type bearings. 	302 313
		HTA0U SS-HTA0U	φ25–φ320 φ25–φ130			<ul style="list-style-type: none"> ULTAGE series HTA0UDB type bearings are fully compatible with 5620 type bearings.
 <p>Tapered roller bearings</p>		329	φ50–φ190	Nominal contact angle of 10° or greater, 17° or smaller	<ul style="list-style-type: none"> Thin-wall type, ISO-compatible metric series. 	318 321
		320	φ20–φ170			

1.2 Ball screw support bearings

Bearing type	Cross section	Bearing type	Bearing bore mm	Contact angle	Remarks	Page
 <p>Angular contact thrust ball bearing for ball screw support</p>	 <p>ULTAGE</p>	BST 2A-BST Open type	φ17–φ55	60°	<ul style="list-style-type: none"> ULTAGE series Surface modification treatment on the bearing ring raceways has led to a longer bearing life and much improved fretting resistance. Owing to prelubrication with a special grease, the sealed type boasts a longer bearing life and simpler maintenance work. All variants are flush ground and are provided with a standard preload. 	344 349
		BST LXL/L588 2A-BST LXL/L588 Light-contact sealed type				
 <p>Double-row thrust angular contact ball bearing unit for ball screw support</p>	 <p>ULTAGE</p>	BSTU LLX/L588 Light-contact sealed type	φ20–φ100	60°	<ul style="list-style-type: none"> ULTAGE series. Greater high-load capacity with optimizations made to the internal bearing design. Use of newly developed light-contact seal to achieve both low torque and high dust resistance. Long operating life, and use of special grease with high fretting resistance. Outer ring mounting hole, and sealed grease lubrication groove for easier handling. 	350 353
		HT	φ6–φ40	30°	<ul style="list-style-type: none"> The allowable axial load of this bearing type is greater owing to the improved interior design. 	354 355
 <p>Needle roller bearings with double-direction thrust needle roller bearing</p>		AXN	φ20–φ50	—	<ul style="list-style-type: none"> A clearance remains between the inner ring of radial bearing and the inner rings of both thrust bearings, allowing the user to determine the preload by, for example, tightening a nut etc. The targeted preload is attained based on the starting torque. The bearing clearance on certain preloaded bearings is controlled in advance so that an intended preload is attained by fully tightening the inner rings on both thrust bearing with nuts, or equivalent means. 	356 357
		ARN	φ20–φ70	—		358 359

2. Bearing Selection and Shaft & Housing Design

2.1 Bearing selection

Generally, the optimal bearing must be selected to suit the nature of the machine, the area within the machine, the spindle specification, bearing type, lubrication system and drive system of the intended machine through considerations of the design life,

precision, rigidity and critical speed, etc. of the bearing. **Table 2.1** summarizes a typical bearing selection procedure, and **Table 2.2** gives an example flowchart according to which considerations are made to select an optimal main spindle bearing for a machine tool.

Table 2.1 Bearing selection procedure

Step	Items being considered	Items being confirmed
Confirm operating conditions of bearing and consider bearing type.	<ul style="list-style-type: none"> Function and construction of components to house bearings Bearing mounting location Dimensional limitations Magnitude and direction of bearing load Magnitude of vibration and shock load Shaft speed Bearing arrangement (fixed side, floating side) Noise and torque of the bearing Bearing operating temperature range Bearing rigidity Installation/disassembly requirements Maintenance and inspection Cost-effectiveness Allowable misalignment of inner/outer rings 	Determine bearing type and arrangement.
Select bearing dimensions.	<ul style="list-style-type: none"> Design life of components to house bearings Dynamic/static equivalent load conditions Safety factor S_o Allowable speed Allowable axial load 	Determine bearing dimensions.
Select bearing tolerances.	<ul style="list-style-type: none"> Shaft runout tolerances Torque fluctuation High speed operation 	Decide bearing grade.
Select bearing internal clearance.	<ul style="list-style-type: none"> Material and shape of shaft and housing Fits Temperature difference between inner and outer rings Allowable misalignment of inner/outer rings Magnitude and nature of load Amount of preload 	Decide bearing internal clearance.
Select cage.	<ul style="list-style-type: none"> Rotational speed Noise level Vibration and shock load Lubrication 	Determination of cage type
Select lubrication method.	<ul style="list-style-type: none"> Operating temperature Rotational speed Lubrication method Sealing method Maintenance and inspection 	Decide lubrication method, lubricant, and sealing method.
Consider special specifications.	<ul style="list-style-type: none"> Operating conditions (special environments: high or low temperature, chemical) Requirement for high reliability 	Decide special bearing specifications.
Select installation and disassembly procedures.	<ul style="list-style-type: none"> Mounting dimensions Installation and disassembly procedures 	Decide installation and disassembly procedures.

Table 2.2 Bearing selection flow chart for machine tool spindles

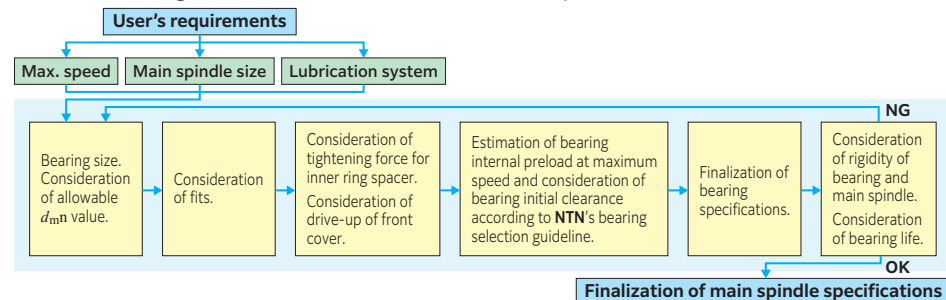

The articles necessary for basic considerations in selecting an optimal main spindle bearing for machine tool are summarized in **Table 2.3**.

Table 2.3 Selection procedure for bearings for main spindles of machine tools

(1) Type of Machine	NC Lathe, machining center, grinding machine, etc.
(2) Main spindle orientation	Vertical, horizontal, variable-direction, inclined, etc.
(3) Diameter and size of main spindle	#30, #40, #50, etc.
(4) Shape and mounting-related dimensions of main spindle	<p>Fig. 2.1 Main spindle shape and mounting-related dimensions (example)</p>
(5) Intended bearing type, bearing size, and preloading method	Front (angular contact type, cylindrical roller type) or rear (angular contact type, cylindrical roller type) preloading system (fixed-position preloading, fixed-pressure preloading)
(6) Slide system free side	Cylindrical roller bearing, ball bushing (availability of cooling)
(7) Lubrication method	Grease, air-oil, oil mist (MicronLub)
(8) Drive system	Built-in motor, belt drive, coupling
(9) Presence/absence of jacket cooling arrangement on bearing area	w/, w/o
(10) Jacket cooling conditions	Synchronization with room temperature, machine-to-machine synchronization, oil feed rate (L/min)
(11) Operating speed range	Max. speed (min ⁻¹) Normal speed range (min ⁻¹) Operating speed range (min ⁻¹)
(12) Load conditions (machining conditions)	Load center Applied load Radial load F_r (N) Axial load F_a (N) Speed Machining frequency Intended bearing life

2.2 Bearing accuracy

Bearing accuracy

Accuracies of rolling bearings, that is, dimensional accuracy and running accuracy of rolling bearings are defined by applicable ISO standards and JIS B 1514 standard (Rolling bearings - Tolerances) (see **Table 2.4** and **Table 2.5**). The dimensional accuracy governs the tolerances that must be satisfied when mounting a bearing to a shaft or housing, while the running accuracy defines a permissible

run-out occurring when rotating a bearing by one revolution. Methods for measuring the accuracy of rolling bearings (optional methods) are described in JIS B 1515 (Measuring methods for rolling bearings).

Table 2.6 summarizes some typical methods for measuring running accuracy of rolling bearings.

Table 2.4 Bearing types and applicable tolerance

Bearing type		Applicable standard	Tolerance class				
Angular contact ball bearings		JIS B 1514-1 (ISO 492)	Class 0	Class 6	Class 5	Class 4	Class 2
Cylindrical roller bearings			Class 0	Class 6	Class 5	Class 4	Class 2
Needle roller bearings			Class 0	Class 6	Class 5	Class 4	—
Tapered roller bearings	Metric	JIS B 1514	Class 0,6X	(Class 6) ¹⁾	Class 5	Class 4	—
	Inch	ANSI/ABMA Std.19	Class 4	Class 2	Class 3	Class 0	Class 00
	J series	ANSI/ABMA Std.19.1	Class K	Class N	Class C	Class B	Class A
Double-direction angular contact thrust ball bearings		NTN standard	—	—	Class 5	Class 4	—

1) The class is the NTN standard class.

Table 2.5 Comparison of tolerance classifications of national standards

Standard	Applicable standard	Tolerance Class					Bearing Types
Japanese industrial standard (JIS)	JIS B 1514	Class 0,6X	Class 6	Class 5	Class 4	Class 2	All type
International Organization for Standardization (ISO)	ISO 492	Normal class Class 6X	Class 6	Class 5	Class 4	Class 2	Radial bearings
	ISO 199	Normal class	Class 6	Class 5	Class 4	—	Thrust bearings
	ISO 578	Class 4	—	Class 3	Class 0	Class 00	Tapered roller bearings (Inch series)
	ISO 1224	—	—	Class 5A	Class 4A	—	Precision instrument bearings
Deutsches Institut für Normung (DIN)	DIN 620	P0	P6	P5	P4	P2	All type
American National Standards Institute (ANSI)	ANSI/ABMA Std.20 ¹⁾	ABEC-1 RBEC-1	ABEC-3 RBEC-3	ABEC-5 RBEC-5	ABEC-7	ABEC-9	Radial bearings (Except tapered roller bearings)
American Bearing Manufacturer's Association (ABMA)	ANSI/ABMA Std.19.1	Class K	Class N	Class C	Class B	Class A	Tapered roller bearings (Metric series)
	ANSI/ABMA Std.19	Class 4	Class 2	Class 3	Class 0	Class 00	Tapered roller bearings (Inch series)

1) "ABEC" is applied for ball bearings and "RBEC" for roller bearings.

Notes 1: JIS B 1514, ISO 492 and 199, and DIN 620 have the same specification level.

2: The tolerance and allowance of JIS B 1514 are slightly different from those of ABMA standards.

To attain a higher level of running accuracy required of a main spindle of machine tool, a high-precision bearing that satisfies the user's main spindle specifications must be chosen. Usually, a high-precision bearing per JIS accuracy Class 5, 4 or 2 is selected according to an intended application. In particular, the radial run-out, axial run-out and non-repetitive run-out of a main spindle bearing greatly affect the running accuracy of the main spindle and therefore have to be strictly controlled. With the recent super high-precision machine tools, the control of N.R.R.O. (Non-Repetitive Run-Out) has increasing

importance, and the main spindle on a turning machine or machining center incorporates an N.R.R.O. accuracy controlled bearing. For further information about N.R.R.O., refer to the following section. Note that to attain a higher accuracy with a main spindle, careful considerations need to be exercised for the accuracies (circularity, cylindricity, coaxiality) of machine components other than a bearing (shaft, housing) as well as machining method and finish accuracy of the shaft and housing. For the information about the accuracies of shaft and housing, refer to a section given later.

Table 2.6 Measuring methods for running accuracies

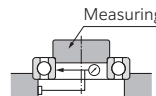
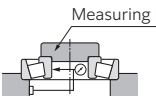
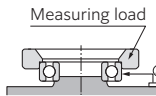
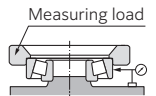
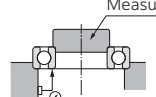
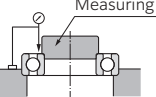
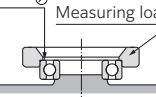
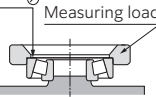
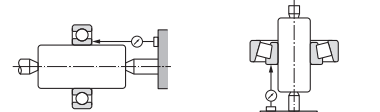
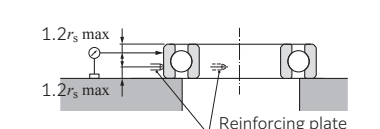
Accuracy characteristics	Measurement methods		
Radial runout of inner ring of assembled bearing (K_{ia})			Radial runout of the inner ring is the difference between the maximum and minimum reading of the measuring device when the inner ring is turned one revolution.
Radial runout of outer ring of assembled bearing (K_{ea})			Radial runout of the outer ring is the difference between the maximum and minimum reading of the measuring device when the outer ring is turned one revolution.
Axial runout of inner ring of assembled bearing (S_{ia})			Axial runout of the inner ring is the difference between the maximum and minimum reading of the measuring device when the inner ring is turned one revolution.
Axial runout of outer ring of assembled bearing (S_{ea})			Axial runout of the outer ring is the difference between the maximum and minimum reading of the measuring device when the outer ring is turned one revolution.
Perpendicularity of inner ring face with respect to the bore (S_d)			The squareness of the inner ring side surface is the difference between the maximum and minimum readings of the measuring device when the inner ring is turned one revolution together with the tapered mandrel.
Perpendicularity of outer ring outside surface with respect to the face (S_{Dp})			The squareness of the outer ring outside diameter surface is the difference between the maximum and minimum readings of the measuring device when the outside ring is turned one revolution along the reinforcing plate.

■ N.R.R.O. (Non-Repetitive Run-Out) of bearing

Accuracies of rolling bearings are defined by applicable ISO standards and a JIS (Japanese Industrial Standards) standard, wherein the accuracies are discussed under the descriptions of radial run-out (K_{1a}), axial run-out (S_{1a}), etc. According to the methods for measuring running accuracies in **Table 2.6**, run-out is read by turning a bearing by only one revolution (each reading is synchronized with the revolution of the bearing being analyzed).

In fact, however, a rolling bearing for machine tool is used in a continuous revolving motion that involves more than one revolution. As a result, the actual run-out accuracy with a rolling bearing includes elements that are not synchronous with the revolution of the bearing (for example, a difference in diameter among rolling elements involved, as well as roundness on the raceway surfaces of inner ring and outer ring), causing the trajectory of

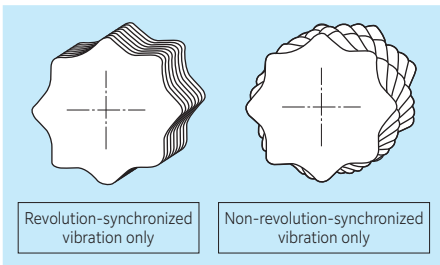

Fig. 2.2

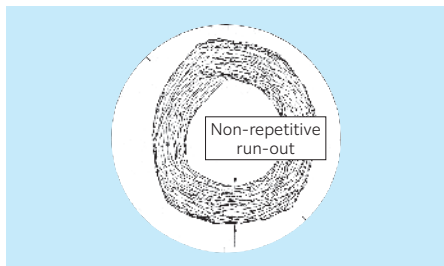

Fig. 2.3 Lissajous figure

plotting with running accuracies to vary with each revolution.

The run-out of an element not in synchronization with the revolutions of bearing is known as N.R.R.O. (Non- Repetitive Run-Out) and is equivalent to the amplitude in the Lissajous figure illustrated in **Fig. 2.3**.

The effect of N.R.R.O. on a rolling bearing onto the accuracies is illustrated in **Fig. 2.4** by taking a main spindle of turning machine as an example.

This diagram illustrates a machining process where the outside surface of a work piece mounted to the main spindle is shaved by a turning operation. If the outside surface is cut with a new trajectory with every revolution, the outside shape of work piece will be distorted. Furthermore, if the accuracies of shaft and housing are not high enough or bearings are assembled onto the shaft and/or housing improperly, the bearing ring can be deformed, possibly leading to a run-out that is not in synchronization with the revolutions of bearing.

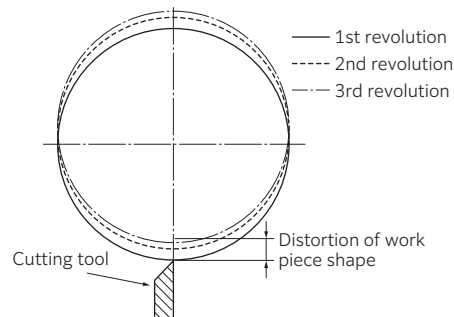

Fig. 2.4 Model of cutting operation

■ Accuracies of shaft and housing

Depending on the fit of a bearing to a shaft and a housing, the bearing internal clearance can vary. For this reason, an adequate bearing fit has to be attained so that the bearing can perform as designed (Refer to the recommended fits section).

Also, the axial tightening torque on a bearing needs to be considered. To avoid deformation of bearing raceway surface owing to axial tightening of the bearing, it is necessary to carefully determine the dimensions of components associated with a tightening force the magnitude of tightening force and the number of tightening bolts.

The clearance on a tapered bore cylindrical roller bearing is adjusted by changing the drive-up to the taper. Because of this, the critical factors associated with an appropriate fit of a bearing to a shaft and/or a housing are the dimensional accuracies of the taper, contact surface on the taper, and the squareness of the end face of the inner ring relative to the shaft centerline during the drive-up process.

Typical accuracy values for a spindle and housing are summarized in **Table 2.7** and **Table 2.8**.

Typical accuracy for spindle

Table 2.7 Form accuracy of spindle ¹⁾

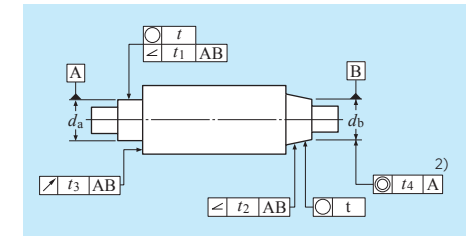

Accuracy	Symbol	Tolerance ³⁾	Fundamental permissible tolerance IT		
			P5	P4	P2
Deviation from circular form	○	t	$\frac{IT3}{2}$	$\frac{IT2}{2}$	$\frac{IT0^{4)}$
Angularity	∠	t_1	$\frac{IT3}{2}$	$\frac{IT2}{2}$	$\frac{IT0^{4)}$
	∠	t_2	—	$\frac{IT3}{2}$	$\frac{IT2}{2}$
Run out	↗	t_3	IT3	IT3	IT2
Eccentricity	◎	t_4	IT5	IT4	IT3

1) The form tolerance, symbol, and reference face of spindle are in accordance with ISO R1101.

2) The length of the bearing fit surface is often too small to measure concentricity. Therefore, this criterion applies only when the fit surface has a width sufficient as a reference face.

3) When determining a tolerance for permissible form accuracy, the reference dimensions used are shaft diameters d_a and d_b . For example, when using a JIS Class 5 bearing for a dia. 50 mm shaft, the tolerance of roundness is $t = IT3/2 = 4/2 = 2 \mu\text{m}$.

4) IT0 is preferred if the diameter tolerance of the bearing fit surface is IT3.

Typical accuracy for housing

Table 2.8 Form accuracy of housing ¹⁾

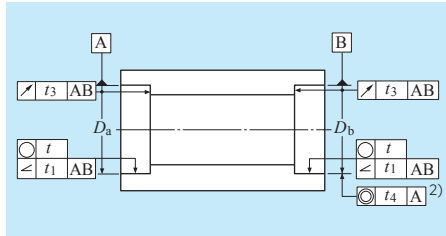

Accuracy	Symbol	Tolerance ³⁾	Fundamental permissible tolerance IT		
			P5	P4	P2
Deviation from circular form	○	<i>t</i>	$\frac{IT3}{2}$	$\frac{IT2}{2}$	$\frac{IT1}{2}$
Angularity	∠	<i>t</i> ₁	$\frac{IT3}{2}$	$\frac{IT2}{2}$	$\frac{IT1}{2}$
Run out	↗	<i>t</i> ₃	IT3	IT3	IT2
Eccentricity	◎	<i>t</i> ₄	IT5	IT4	IT3

- 1) The form tolerance, symbol and reference face of the housing are in accordance with ISO R1101.
- 2) The length of the bearing fit surface is often too small to measure concentricity. Therefore, this criterion applies only when the fit surface has a width sufficient as a reference face.
- 3) Housing bore diameters *D_a* and *D_b* are the reference dimensions used when the tolerance for permissible form accuracy are determined. For example, when a JIS Class 5 bearing is used for a housing with a 50 mm inside bore, the tolerance of roundness is $t = IT3/2 = 5/2 = 2.5 \mu\text{m}$.

Fundamental tolerance IT

Table 2.9 Fundamental tolerance IT

Classification of nominal dimension (mm)		Fundamental tolerance IT value (μm)					
over	incl.	IT0	IT1	IT2	IT3	IT4	IT5
6	10	0.6	1	1.5	2.5	4	6
10	18	0.8	1.2	2	3	5	8
18	30	1	1.5	2.5	4	6	9
30	50	1	1.5	2.5	4	7	11
50	80	1.2	2	3	5	8	13
80	120	1.5	2.5	4	6	10	15
120	180	2	3.5	5	8	12	18
180	250	3	4.5	7	10	14	20
250	315	4	6	8	12	16	23
315	400	5	7	9	13	18	25
400	500	6	8	10	15	20	27

Note) For machine tool spindles, the shaft hardness is recommended to be at least HRC 50 and the housing is recommended to be at least HRC 30 to assist bearing replacement during repairs.

2.3 Bearings and rigidity

The rigidity of the main spindle of a machine tool is associated with both bearing rigidity and shaft rigidity. Bearing rigidity is typically governed by the elastic deformation between the rolling elements and raceway surface under load. Usually, bearings are preloaded in order to increase the rigidity.

Under same loading conditions, a roller bearing has a higher rigidity than a ball bearing of the same size. However, having sliding portions, a roller bearing is disadvantageous in supporting a high speed shaft.

Shaft rigidity is greater with a larger shaft diameter. However, the supporting bearing must have a sufficient size and its $d_m n$ value [pitch center diameter across rolling elements d_m (mm) multiplied by speed n (min^{-1})] must be accordingly greater. Of course, a larger bearing is disadvantageous for high speed applications.

To sum up, the rigidity required of the shaft arrangement must be considered before the bearing rigidity (bearing type and preload) and shaft rigidity are determined.

■ Bearings rigidity

The rigidity of a bearing built into a spindle directly affects the rigidity of the spindle.

In particular, a high degree of rigidity is required of the main spindle of a machine tool to ensure adequate productivity and accurate finish of workpieces.

Bearing rigidity is governed by factors such as the following:

- (1) Types of rolling elements
- (2) Size and quantity of rolling elements
- (3) Material of rolling elements
- (4) Bearing contact angle
- (5) Preload on bearing

■ Type of rolling elements (roller or ball)

The surface contact pattern of the rolling element and raceway is line contact with a roller bearing, while a ball bearing is point contact. As a result, the dynamic deformation of a bearing relative to a given load is smaller with a roller bearing.

■ Size and number of rolling elements

The size and number of rolling elements of a bearing are determined based on the targeted performance of the bearing.

Larger rolling elements lead to a greater bearing rigidity. However, a bearing having larger rolling elements tends to be affected by gyratory sliding centrifugal force, and, as a result, its high speed performance will be degraded. Incidentally, a greater number of rolling elements helps increase bearing rigidity, but at the same time creates an increased number of heat generation sources, possibly leading to greater temperature rise.

For this reason, smaller size of rolling elements are used for high speed applications.

To achieve both "high speed" and "high rigidity", each type of the NTN angular contact ball bearing for a machine tool is manufactured according to optimized specifications for interior structure (see Fig. 2.5).

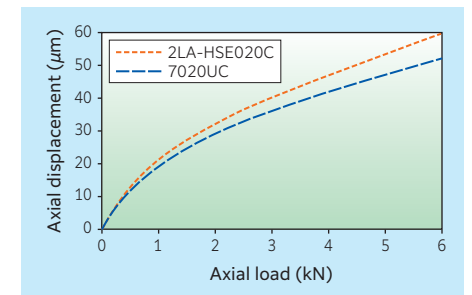

Fig. 2.5

Material of rolling element (ceramic and steel)

Certain NTN bearings incorporate ceramic rolling elements. As Young's modulus of silicon nitride (308 GPa) is greater than that of bearing steel (208 GPa), the rigidity with this type of bearing is accordingly greater (see Fig. 2.6).

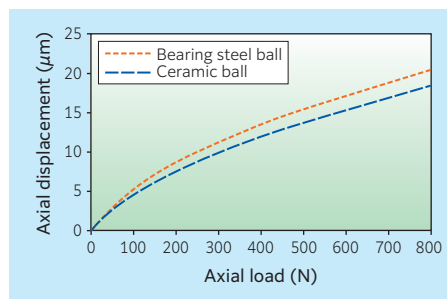

Fig. 2.6

Bearing contact angle

A smaller contact angle on an angular contact ball bearing results in greater radial rigidity. When used as a thrust bearing, this type of bearing should have a greater contact angle to enable greater axial rigidity (see Fig. 2.7).

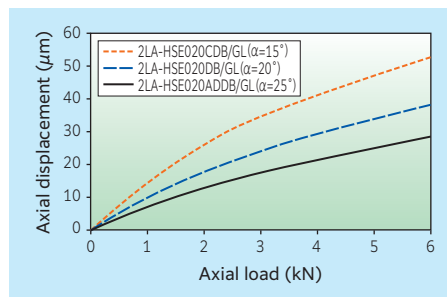

Fig. 2.7

Preload on bearing

A greater preload on a given bearing results in greater rigidity (see Fig. 2.8). However, too great of a preload on a bearing can lead to overheating, seizure, and/or early spalling (flaking) of the bearing. It is possible to use bearings in three- or four-row configurations in order to achieve increased axial rigidity (see Fig. 2.9).

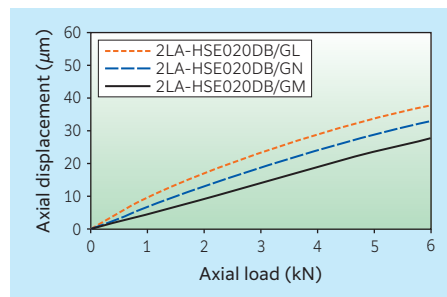

Fig. 2.8

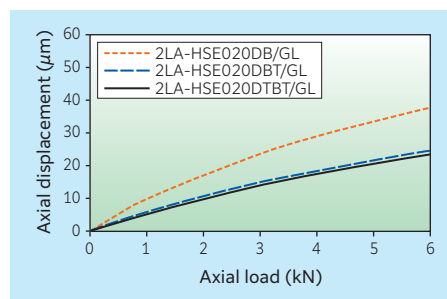

Fig. 2.9

Preloading technique and preload

Bearing preloading techniques can be categorized as fixed position preloading and constant pressure preloading (see Fig. 2.10).

Definite position preloading is useful in enhancing the rigidity of a bearing unit, as the positional relationship across individual bearings can be maintained. On the other hand, as preloading is achieved with spring force, the constant pressure preloading technique can maintain a preload constant even when the bearing-to-bearing distance varies due to heat generation on the spindle or a change in load.

The standard preload for a duplex bearing is given in the relevant section for each bearing.

If an angular contact ball bearing is to be used for a high speed application, such as for the main spindle of a machine tool, determine the optimal preload by considering the increase in contact stress between rolling elements and the raceway surface that results from gyratory sliding and centrifugal force. When considering such an application, consult NTN Engineering.

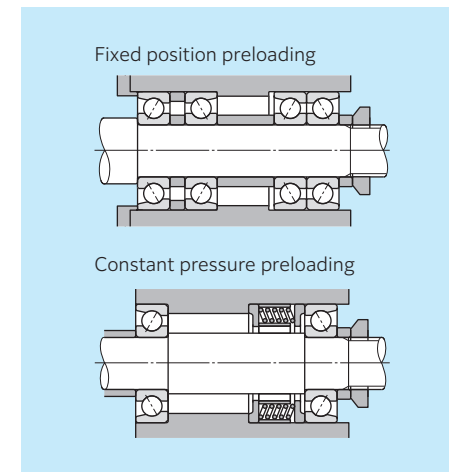

Fig. 2.10

■ Preload and rigidity

The effect of preloading for an increase in bearing rigidity is summarized in Fig. 2.11.

When the inner rings in the diagram are tightened to bring them together, bearings I and II are each axially displaced by dimension δ_o , thereby attaining a preload F_o . In this situation, if an axial load F_a is further exerted from outside, the displacement on bearing

I increases by δ_a , while the displacement on bearing II decreases.

At this point, the loads on bearings I and II are F_I and F_{II} , respectively. When compared with δ_b (the displacement occurring when an axial load F_a is exerted onto a non-preloaded bearing I), displacement δ_a is small. Thus, a preloaded bearing has higher rigidity.

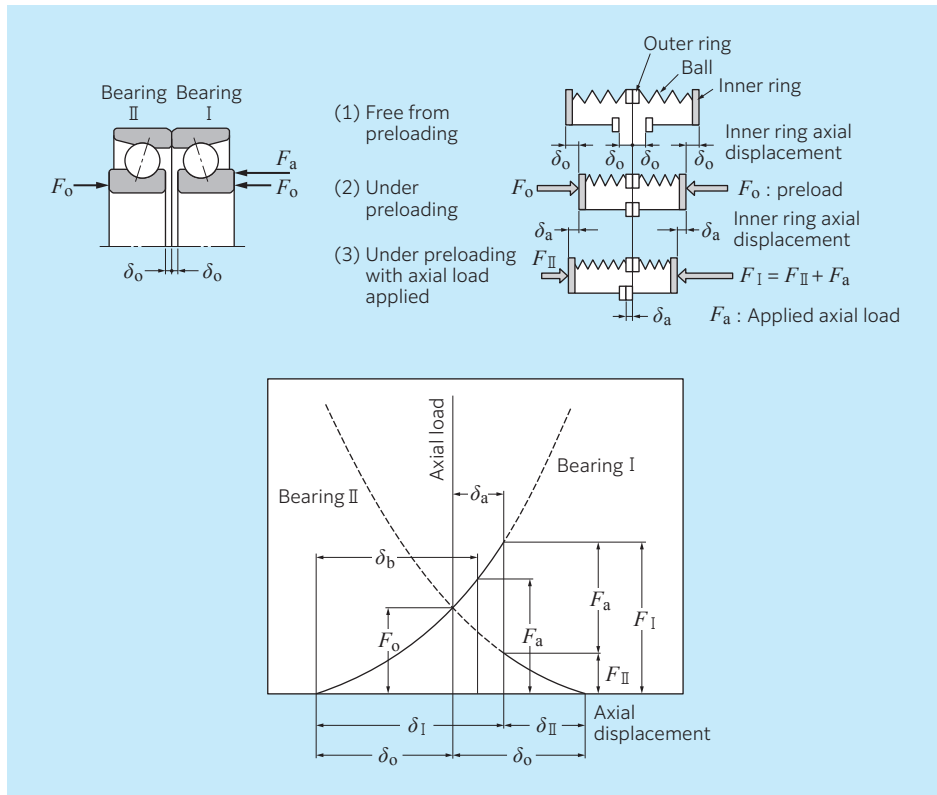

Fig. 2.11 Preload diagram

■ Gyrotory sliding

Every rolling element (ball) in an angular contact ball bearing revolves on the axis of rotation A-A' as illustrated in Fig. 2.12. A revolving object tends to force the axis of rotation to a vertical or horizontal attitude. As a result, the rolling element develops a force to alter the orientation of the axis of rotation. This force is known as a gyrotory moment (M).

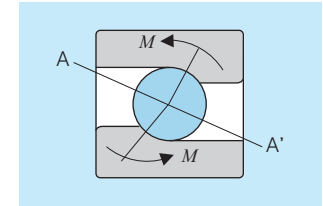

Fig. 2.12 Gyrotory sliding

When the force due to the gyrotory moment is greater than the resistance force (rolling element load multiplied by the coefficient of friction between the raceway and rolling element), gyrotory sliding occurs on the raceway surface. This leads to heat generation, wear and seizure. Therefore, it is necessary to provide a sufficient resistance force to inhibit gyrotory sliding. NTN's recommended preload is based on this theory.

The gyrotory moment that will occur can be calculated by the formula below.

$$M = k \times \omega_b \times \omega_c \times \sin\beta$$

M : Gyrotory moment
 ω_b : Autorotation angular velocity of rolling element
 ω_c : Angular velocity of revolution
 n : Speed of inner ring

$$k = \frac{1}{10} \times m \times d_w^2$$

$$= 0.05 \times \rho \times d_w^5$$

m : Mass of rolling element
 ρ : Density of rolling element
 d_w : Diameter of rolling element
 β : Angle of axis of rotation of rolling element

■ Spin sliding

Every rolling element (ball) in an angular contact ball bearing develops spin sliding that is unavoidable owing to the structure of the bearing, relative to the raceway surface of either the inner ring or outer ring (see Fig. 2.13).

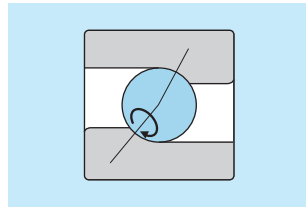
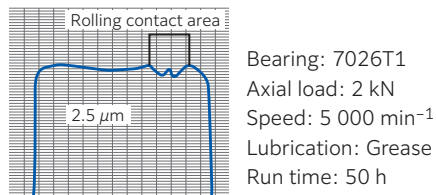

Fig. 2.13 Spin sliding

Usually, at a lower speed range, pure rolling motion occurs between an inner ring raceway and rolling elements and spin sliding develops between an outer ring raceway and rolling elements (this state is known as inner ring control). At a higher speed range, pure rolling motion occurs between an outer ring raceway and rolling elements and spin sliding develops between an inner ring raceway and rolling elements (this state is known as outer ring control). A point where transfer from inner ring control to outer ring control occurs is known as control transfer point. An amount of spin sliding and control transfer point can vary depending on the bearing type and bearing data. Generally, the amount of spin sliding will be greater with an outer ring control state.

The form of wear on the bearing raceway derived from spin sliding appears as . The wear on the raceway surface on inner ring that resulted from spin sliding is given below.



Possible causes for type wear

- (1) Contact ellipse and direction of spin sliding
- (2) Sliding velocity (V)
- (3) Bearing pressure within ellipse (P)
- (4) PV value owing to spin
- (5) Wear on raceway surface

Fig. 2.14 Mechanism of wear on bearing owing to spin sliding

According to J. H. Rumbarger and J. D. Dunfee, when the amount of spin sliding exceeds 4.20×10^6 (N/mm² · mm/s), increase of heat generation and wear start.

The example of wear on a bearing owing to spin sliding is given in Fig. 2.14.

The magnitude of spin-derived wear is governed by a PV value (amount of spin sliding) during operation of the main spindle. Therefore, the optimum bearing for main spindle must be selected. The possibility of spin-derived wear occurrence varies depending on the bearing type, model number and specifications.

Also, the magnitude of spin-derived wear is significantly affected by how well the raceway surface is lubricated. Regardless of the type of sliding, even minor sliding can lead to wear if oil film is not formed well. For this reason, a reliable lubrication arrangement needs to be incorporated.

2.4 Designing shaft and housing

In designing a bearing and housing, it is very important to provide a sufficient shoulder height for the bearing and housing so as to maintain bearing and housing accuracies and to avoid interference with the bearing related corner radius.

The chamfer dimensions are shown in Table 2.10 and the recommended shoulder height and corner radii on the shaft and housing are listed in Table 2.11.

■ Bearing corner radius dimensions

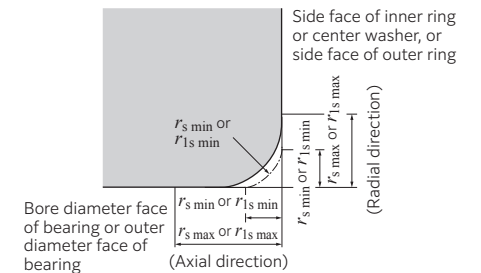

Fig. 2.15

Table 2.10 Allowable critical-value of bearing chamfer (1) Radial bearings (Except tapered roller bearings)

r_{1s} min ¹⁾ or r_{1s} min	Nominal bore diameter d		r_{1s} max or r_{1s} max	
	over	incl.	Radial direction	Axial direction
0.05	—	—	0.1	0.2
0.08	—	—	0.16	0.3
0.1	—	—	0.2	0.4
0.15	—	—	0.3	0.6
0.2	—	—	0.5	0.8
0.3	—	40	0.6	1
	40	—	0.8	1
0.6	—	40	1	2
	40	—	1.3	2
1	—	50	1.5	3
	50	—	1.9	3
1.1	—	120	2	3.5
	120	—	2.5	4
1.5	—	120	2.3	4
	120	—	3	5
2	—	80	3	4.5
	80	220	3.5	5
	220	—	3.8	6
2.1	—	280	4	6.5
	280	—	4.5	7
2.5	—	100	3.8	6
	100	280	4.5	6
	280	—	5	7
3	—	280	5	8
	280	—	5.5	8
4	—	—	6.5	9
5	—	—	8	10
6	—	—	10	13
7.5	—	—	12.5	17
9.5	—	—	15	19
12	—	—	18	24
15	—	—	21	30
19	—	—	25	38

1) These are the allowable minimum dimensions of the chamfer dimension " r " or " r_1 " and are described in the dimensional table.

(2) Metric tapered roller bearings

r_{1s} min ²⁾ or r_{1s} min	Nominal bore ³⁾ diameter of bearing " d " or nominal outside diameter " D "		r_{1s} max or r_{1s} max	
	over	incl.	Radial direction	Axial direction
0.3	—	40	0.7	1.4
	40	—	0.9	1.6
0.6	—	40	1.1	1.7
	40	—	1.3	2
1	—	50	1.6	2.5
	50	—	1.9	3
1.5	—	120	2.3	3
	120	250	2.8	3.5
	250	—	3.5	4
2	—	120	2.8	4
	120	250	3.5	4.5
	250	—	4	5
2.5	—	120	3.5	5
	120	250	4	5.5
	250	—	4.5	6
3	—	120	4	5.5
	120	250	4.5	6.5
	250	400	5	7
	400	—	5.5	7.5
4	—	120	5	7
	120	250	5.5	7.5
	250	400	6	8
	400	—	6.5	8.5
5	—	180	6.5	8
	180	—	7.5	9
6	—	180	7.5	10
	180	—	9	11

2) These are the allowable minimum dimensions of the chamfer dimension " r " or " r_1 " and are described in the dimensional table.

3) Inner rings shall be in accordance with the division of " d " and outer rings with that of " D ".

Note: This standard will be applied to bearings whose dimensional series (refer to the dimensional table) are specified in the standard of ISO 355 or JIS B 1512-3.

For further information concerning bearings outside of these standards or tapered roller bearings using US customary units, please contact NTN Engineering.

■ **Abutment height and fillet radius**

The shaft and housing abutment height (h) should be larger than the bearing's maximum allowable chamfer dimensions ($r_{s \max}$), and the abutment should be designed so that it directly contacts the flat part of the bearing end face. The fillet radius (r_a) must be smaller than the bearing's minimum allowable chamfer dimension ($r_{s \min}$) so that it does not interfere with bearing seating. **Table 2.11** lists abutment height (h) and fillet radius (r_a).

For bearings that support very large axial loads, shaft abutments (h) should be higher than the values in the table.

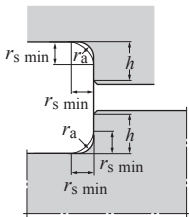

Table 2.11 Fillet radius and abutment height

Unit: mm

Chamfer length $r_{s \min}$ or $r_{1s \min}$	Fillet radius (radius) $r_{as \max}$	Shoulder height h (min)
		Normal use ¹⁾
0.05	0.05	0.3
0.08	0.08	0.3
0.1	0.1	0.4
0.15	0.15	0.6
0.2	0.2	0.8
0.3	0.3	1.25
0.6	0.6	2.25
1	1	2.75
1.1	1	3.5
1.5	1.5	4.25
2	2	5
2.1	2	6
2.5	2	6
3	2.5	7
4	3	9
5	4	11
6	5	14
7.5	6	18
9.5	8	22
12	10	27
15	12	32
19	15	42

1) If bearing supports large axial load, the height of the shoulder must exceed the value given here.

Note: $r_{as \max}$ maximum allowable fillet radius.

Where a fillet radius ($r_{a \max}$) larger than the bearing chamfer dimension is required to strengthen the shaft or to relieve stress concentration [see **Fig. 2.16 (a)**], or where the shaft abutment height is too low to afford adequate contact surface with the bearing [see **Fig. 2.16 (b)**], spacers may be used effectively.

Relief dimensions for ground shaft and housing fitting surfaces are given in **Table 2.12**.

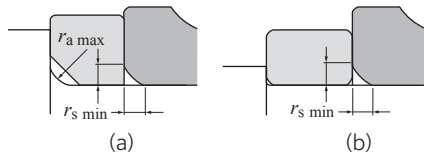

Fig. 2.16 Bearing mounting with spacer

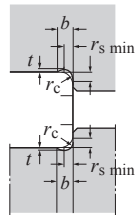

Table 2.12 Relief dimensions for grounding

Unit: mm

$r_{s \min}$	Relief dimensions		
	b	t	r_c
1	2	0.2	1.3
1.1	2.4	0.3	1.5
1.5	3.2	0.4	2
2	4	0.5	2.5
2.1	4	0.5	2.5
2.5	4	0.5	2.5
3	4.7	0.5	3
4	5.9	0.5	4
5	7.4	0.6	5
6	8.6	0.6	6
7.5	10	0.6	7

3. Load Rating and Life

3.1 Bearing life

Even in bearings operating under normal conditions, the surfaces of the raceway and rolling elements are constantly being subjected to repeated compressive stresses which causes spalling (flaking, separation) of these surfaces to occur. This spalling is due to material fatigue and will eventually cause the bearings to fail. The effective life of a bearing is usually defined in terms of the total number of revolutions a bearing can undergo before spalling of either the raceway surface or the rolling element surfaces occurs.

Other causes of bearing failure are often attributed to problems such as seizure, abrasions, cracking, chipping, scuffing, rust, etc. However, these so called "causes" of bearing failure are usually caused by improper installation, insufficient or improper lubrication, faulty sealing or improper bearing selection. Since the above mentioned "causes" of bearing failure can be avoided by taking the proper precautions, and are not simply caused by material fatigue, they are considered separately from the spalling aspect.

Usually, the load exerted on the main spindle of a machine tool is relatively small compared to the dynamic rated load on the bearing. Therefore, the fatigue life of a bearing seldom poses a problem.

The following operating conditions, rather than a bearing's rating life, can significantly affect the bearing functions (running accuracy, rigidity, heat generation, etc.) and require special consideration.

- (1) High speed operation.
- (2) Heavy preload.
- (3) Large bending of the shaft.
- (4) Large temperature difference between the inner and outer rings.

For further information, please consult **NTN Engineering**.

■ **Basic rating life and basic dynamic load rating**

A group of seemingly identical bearings when subjected to identical load and operating conditions will exhibit a wide diversity in their durability.

This "life" disparity can be accounted for by the difference in the fatigue of the bearing material itself. This disparity is considered statistically when calculating bearing life, and the basic rating life is defined as follows.

The basic rating life is based on a 90 % statistical model which is expressed as the total number of revolutions 90 % of the bearings in an identical group of bearings subjected to identical operating conditions will attain or surpass before flaking due to material fatigue occurs. For bearings operating at fixed constant speeds, the basic rating life (90 % reliability) is expressed in the total number of hours of operation.

Basic dynamic load rating expresses a rolling bearing's capacity to support a dynamic load. The basic dynamic load rating is the load under which the basic rating life of the bearing is 1 million revolutions. This is expressed as pure radial load for radial bearings and pure axial load for thrust bearings. These are referred to as "basic dynamic load rating (C_r)" and "basic dynamic axial load rating (C_a).". The basic dynamic load ratings given in the bearing tables of this catalog are for bearings constructed of **NTN** standard bearing materials, using standard manufacturing techniques.

The relationship between the basic rating life, the basic dynamic load rating and the bearing load is given in the formula below.

$$\text{For ball bearings: } L_{10} = \left(\frac{C}{P}\right)^3 \dots\dots\dots (3.1)$$

$$L_{10h} = \frac{10^6}{60n} \left(\frac{C}{P}\right)^3 \dots\dots (3.2)$$

For roller bearings: $L_{10} = \left(\frac{C}{P}\right)^{10/3}$ (3.3)

$$L_{10h} = \frac{10^6}{60n} \left(\frac{C}{P}\right)^{10/3} \dots (3.4)$$

Where:

- L_{10} : Basic rating life, 10^6 revolutions
- L_{10h} : Basic rating life, h
- C : Basic dynamic load rating, N {kgf}
(C_r : radial bearings, C_a : thrust bearings)
- P : Equivalent dynamic load, N {kgf}
(P_r : radial bearings, P_a : thrust bearings)
- n : Rotational speed, min^{-1}

When several bearings are incorporated in machines or equipment as complete units, all the bearings in the unit are considered as a whole when computing bearing life (see formula 3.5).

$$L = \frac{1}{\left(\frac{1}{L_1^e} + \frac{1}{L_2^e} + \dots + \frac{1}{L_n^e}\right)^{1/e}} \dots (3.5)$$

Where:

- L : Total basic rating life of entire unit, h
- $L_1, L_2 \dots L_n$: Basic rating life of individual bearings, 1, 2, ... n, h
- $e = 10/9$ For ball bearings
- $e = 9/8$ For roller bearings

When the load conditions vary at regular intervals, the life can be given by formula (3.6).

$$L_m = \left(\frac{\phi_1}{L_1} + \frac{\phi_2}{L_2} + \dots + \frac{\phi_j}{L_j}\right)^{-1} \dots (3.6)$$

Where:

- L_m : Total life of bearing, h
- ϕ_j : Frequency of individual load conditions ($\sum \phi_j = 1$)
- L_j : Life under individual conditions, h

Adjusted rating life

The basic bearing rating life (90 % reliability factor) can be calculated by the formula (3.2) mentioned. However, in some applications a bearing life factor of over 90 % reliability may be required. To meet these requirements, bearing life can be lengthened by the use of specially improved bearing materials or manufacturing process. Bearing life is also sometimes affected by operating conditions such as lubrication, temperature and rotational speed.

Basic rating life adjusted to compensate for this is called "adjusted rating life," and is determined by using the formula (3.7).

$$L_{na} = a_1 \cdot a_2 \cdot a_3 \cdot L_{10} \dots (3.7)$$

Where:

- L_{na} : Adjusted rating life in millions of revolutions (10^6)
- a_1 : Reliability factor
- a_2 : Bearing characteristics factor
- a_3 : Operating conditions factor

Life adjustment factor for reliability a_1

The value of reliability factor a_1 is provided in **Table 3.1** for reliability of 90 % or greater.

Table 3.1 Reliability factor a_1

Reliability %	L_n	Reliability factor a_1
90	L_{10}	1.00
95	L_5	0.64
96	L_4	0.55
97	L_3	0.47
98	L_2	0.37
99	L_1	0.25
99.2	$L_{0.8}$	0.22
99.4	$L_{0.6}$	0.19
99.6	$L_{0.4}$	0.16
99.8	$L_{0.2}$	0.12
99.9	$L_{0.1}$	0.093
99.92	$L_{0.08}$	0.087
99.94	$L_{0.06}$	0.080
99.95	$L_{0.05}$	0.077

Life adjustment factor for material a_2

Bearing characteristics concerning life vary according to bearing material, quality of material and use of special manufacturing processes. In this case, life is adjusted by the bearing characteristics factor a_2 .

The basic dynamic load ratings listed in the catalog are based on **NTN's** standard material and process, therefore, the adjustment factor $a_2 = 1$. $a_2 > 1$ may be used for specially enhanced materials and manufacturing methods. If this applies, consult **NTN Engineering**.

Life adjustment factor for operating conditions a_3

Operating conditions factor a_3 is used to compensate for when the lubrication condition worsens due to rise in temperature or rotational speed, lubricant deteriorates, or becomes contaminated with foreign matters.

Generally speaking, when lubricating conditions are satisfactory, the a_3 factor has a value of one. And when lubricating conditions are exceptionally favorable and all other operating conditions are normal, a_3 can have a value greater than one. a_3 is however less than 1 in the following cases:

- Dynamic viscosity of lubricating oil is too low for bearing operating temperature (13 mm^2/s or less for ball bearings, 20 mm^2/s for roller bearings)
- Rotational speed is particularly low (pitch circle diameter across rolling elements d_m mm and rotational speed n min^{-1} is $d_m n$ value $< 10\,000$)
- Bearing operating temperature is too high
- Lubricant is contaminated with foreign matter or moisture

Life calculation for machine tool main spindle bearing

By dramatic improvement in bearing materials and bearing manufacturing techniques, bearings can offer a life several times as long as that calculated from the formula (3.7) as long as they are mounted with minimal mounting errors and are fully free from foreign matter and adequately lubricated. This finding was obtained by a series of experiments performed by **NTN**. The formula for calculating life of a machine tool main spindle bearing uses the life correction factor, a_{NTN} . This correction factor is based on a contact stress of 1.5 GPa at the fatigue limit specified in ISO 281: 1990/Amd. 2: 2000 under clean and well lubricated conditions.

Bearing life theory

(1) Conventional Lundberg-Palmgren (L-P) theory

According to this theory, a stress that governs rolling fatigue is considered, that is, a maximum dynamic shear stress τ_0 that is exerted, at a depth of Z_0 from the rolling contact surface, in a plane parallel with the rolling contact surface. Referring to a theory of Neuber, et. al. which claims that the durability of a material deteriorates as the volume being subjected to a stress application decreases, the L-P theory assumes that a fissure occurring at a weak point of material at around the depth Z_0 reaches the surface and leads to develop failure [spalling (flaking, separation)]. The probability of survival S of a volume V that is subjected to N times of stress application is determined by the formula below according to the Weibull theory.

$$\ell_n \frac{1}{S} \propto \frac{N^e \tau_0^c V}{z_0^h} \dots\dots\dots (3.8)$$

Where:

- S : Probability of survival of stress volume V
- N : Number of repeated stress applications
- e : Weibull slope (index to represent variation in life)
- τ_0 : Maximum shear stress
- Z_0 : Depth from surface at which maximum shear stress occurs
- c, h : Indexes

From the basic formula for the bearing life relative to rolling fatigue (3.8), a generic life formula below is obtained:

$$L_{10} = \left(\frac{C}{P}\right)^p \dots\dots\dots (3.9)$$

Where:

- L_{10} : Basic rating life, 10^6 revolutions
- C : Basic dynamic load rating, N {kgf}
- P : Dynamic equivalent load, N {kgf}
- p : $(c - h + 2) / 3e$ (point contact)
 $(c - h + 1) / 2e$ (line contact)

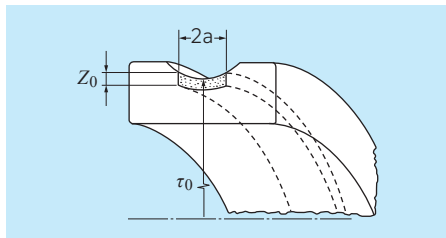

Fig. 3.1 Stress volume resulting from rolling contact according to L-P theory

(2) NTN's new bearing life theory

While the L-P theory intends to define internally occurring spalling owing to the shear stress within a material that results from hertzian contact, **NTN's** new bearing life theory is designed not only to evaluate surface-initiated spalling but also to determine life of each small segment (ΔL_1) based on a local stress (σ_1). This is done by dividing an area from the interior to the contact surface of the material into small segments as illustrated in **Fig. 3.2**, and finally obtaining the overall bearing life L by the formula (3.12).

$$\ell_n \frac{1}{\Delta S_i} \propto \frac{\Delta N_i^e \sigma_i^c \Delta V_i}{z_i^h} \dots\dots\dots (3.10)$$

$$\Delta L_i = \Delta N_i \propto (\sigma_i^{-c} \Delta V_i^{-1} z_i^h)^{1/e} \dots\dots\dots (3.11)$$

$$L = \left\{ \sum_{i=1}^n \Delta L_i^{-e} \right\}^{-1/e} \dots\dots\dots (3.12)$$

Where:

- ΔS_i : probability of survival of stress volume ΔV_i of divided segment
- L : Overall bearing life
- Z_i : Depth of divided small stress volume ΔV_i from the surface
- n : Number of segments
- σ_u : Fatigue limit stress
- A stress below which a bearing does not develop failure [spalling (flaking, separation)] under ideal lubrication conditions.
- ISO 281: 1990/Amd. 2: 2000 specifies 1.5 GPa as a the maximum contact stress at a fatigue limit. **NTN** uses it as a Von Mises stress equivalent to the maximum contact stress 1.5 GPa.
- When σ_i is smaller than σ_u (fatigue limit), the life of a region in question (ΔL_1) will be infinitely long.

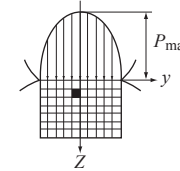

Fig. 3.2 Calculation model

■ **NTN's new bearing life formula**

The correlation between the **NTN's** life correction factor a_{NTN} and corrected rating life L_{nm} is defined by the formula (3.13) below.

$$L_{nm} = a_1 \cdot a_{NTN} \cdot \left(\frac{C}{P}\right)^p \dots\dots\dots (3.13)$$

Where:

- L_{nm} : Corrected rating life, 10^6 revolutions
- a_1 : Reliability coefficient
- a_{NTN} : Life correction factor that reflects material properties, fatigue limit stress, contamination with foreign matter and oil film parameter (Λ) ($0.1 \leq a_{NTN} \leq 50$)
- C : Basic dynamic load rating, N {kgf}
- P : Dynamic equivalent load, N {kgf}
- p : Index 3 (ball bearing) 10/3 (roller bearing)

(1) Effect of fatigue limit

NTN's new bearing life formula introduces a concept of fatigue life according to which the bearing life is infinitely long at a particular contact stress as illustrated in **Fig. 3.3** assuming no foreign matter is trapped in the bearing and the bearing is reliably lubricated.

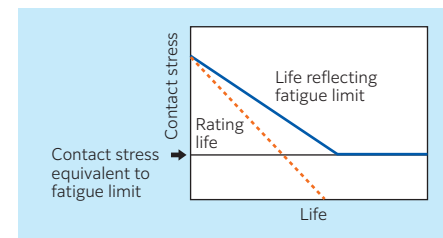

Fig. 3.3 Basic concept of fatigue limit

(2) Effect of foreign matter

The effect of foreign matter is treated as surface-initiated spalling that starts from a dent resulting from trapped foreign matter. **NTN** performs a bearing life calculation, assuming that the size of foreign matter and the stress concentration area in the middle portion (the size of this area corresponds with that of the foreign matter) in the surface layer as well as the amount of foreign matter significantly affect the bearing life.

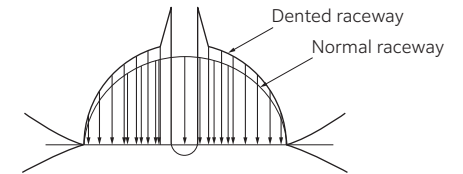

Fig. 3.4 Contact stress distribution resulting from dent

(3) Effect of oil film parameter (Λ)

The oil film parameter can be used to calculate bearing life. The oil film parameter, designated by Λ , is the ratio of the oil film thickness to the roughness of the surface. It can be used to calculate the average stress across the surface layer of two contacting surfaces, such as a rolling element and raceway. From this surface layer stress, the contact stress can be determined. Bearing life is then calculated from the contact stress.

[Conditions of two objects on surface layer]
Calculation model

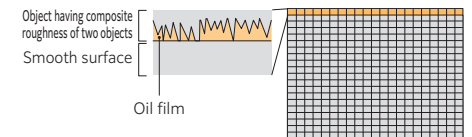

Fig. 3.5 Model of stress load onto the surface layer

■ New life calculation formula chart

Various statuses of contamination with foreign matter are defined in **Table 3.2**. The values of ISO codes and NAS classes are those for ball bearings that are subjected to more severe operating conditions.

Table 3.2 Status of contamination

Condition of contamination	Extremely clean	Clean	Normal	Lightly contaminated	Moderately contaminated	Highly contaminated	Severely contaminated
Contamination coefficient	1	0.8	0.5	0.4	0.3	0.2	0.1
Guideline for application	Filtered						No filter
	Less than 10 μm	10 to 30 μm	30 to 50 μm	50 to 70 μm	70 to 100 μm	100 μm or more	Ingress of much dust
ISO cleanliness code (ISO 4406)	13/10	15/12	17/14	19/16	21/18	23/20	25/22
NAS class	4	6	8	10	12	—	—

(1) Effect of foreign matter on correlation between load (P/C) and life correction factor a_{NTN}

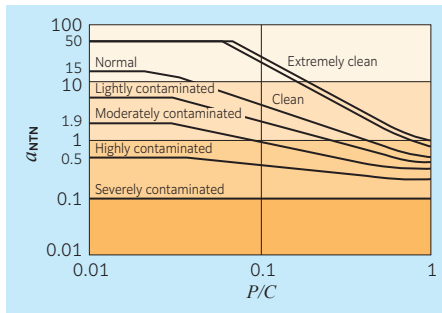

Fig. 3.6 Correlation between P/C and a_{NTN} (effect of foreign matter in ball bearing)

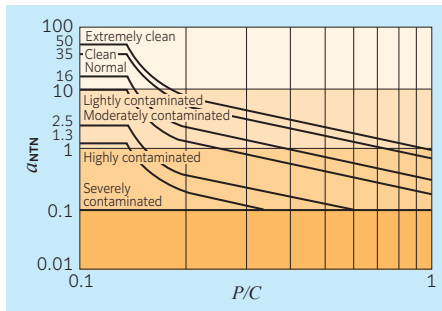

Fig. 3.7 Correlation between P/C and a_{NTN} (effect of foreign matter in roller bearing)

(2) Effect of oil film parameter (Λ) on correlation between load (P/C) and life correction factor a_{NTN}

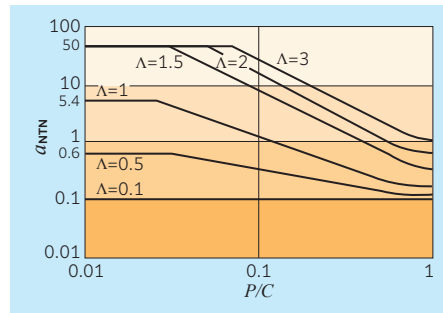

Fig. 3.8 Correlation between P/C and a_{NTN} (effect of Λ with ball bearing)

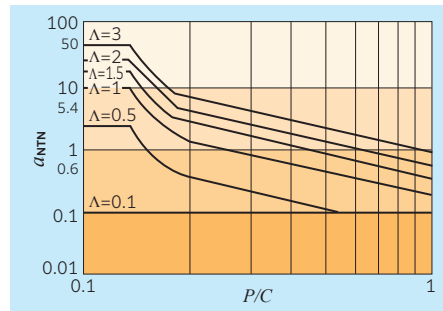

Fig. 3.9 Correlation between P/C and a_{NTN} (effect of Λ with roller bearing)

3.2 Static load rating and allowable axial load

■ Basic static load rating

When stationary rolling bearings are subjected to static loads, they suffer from partial permanent deformation of the contact surfaces at the contact point between the rolling elements and the raceway. The amount of deformity increases as the load increases, and if this increase in load exceeds certain limits, the subsequent smooth operation of the bearings is impaired.

It has been found through experience that a permanent deformity of 0.0001 times the diameter of the rolling element, occurring at the most heavily stressed contact point between the raceway and the rolling elements, can be tolerated without any impairment in running efficiency.

The basic static load rating refers to a fixed static load limit at which a specified amount of permanent deformation occurs. It applies to pure radial loads for radial bearings and to pure axial loads for thrust bearings. The maximum applied load values for contact stress occurring at the rolling element and raceway contact points are given below.

For ball bearings 4 200 MPa
For roller bearings 4 000 MPa

Referred to as “basic static radial load rating” for radial bearings and “basic static axial load rating” for thrust bearings, basic static load rating is expressed as C_{0r} or C_{0a} respectively and is provided in the bearing dimensions table.

■ Allowable static equivalent load

Generally the static equivalent load which can be permitted is limited by the basic static rating load as stated above. However, depending on requirements regarding friction and smooth operation, these limits may be greater or lesser than the basic static rating load.

This is generally determined by taking the safety factor S_0 given in **Table 3.3** and formula (3.14) into account.

$$S_0 = C_0 / P_0 \quad (3.14)$$

Where:

S_0 : Safety factor

C_0 : Basic static load rating, N {kgf}
radial bearings: C_{0r}

thrust bearings: C_{0a}

P_0 : Static equivalent load, N {kgf}
radial bearings: P_{0r}
thrust bearings: P_{0a}

Table 3.3 Minimum safety factor values S_0

Operating conditions	Ball bearings	Roller bearings
Applications that require quiet rotation	2	3
Applications subjected to impact loads	1.5	3
Normal rotation applications	1	1.5

Note: When vibration and/or shock loads are present, a load factor based on the shock load needs to be included in the P_0 max value.

■ Allowable axial load

A greater axial load can be exerted on a main spindle bearing on a machine tool allowing for tool changes while the machine is stationary. When an angular contact ball bearing is subjected to a larger axial load, the contact ellipse between its rolling elements and raceway surface can overflow the raceway surface (see Fig. 3.10). Furthermore, even if the contact ellipse remains within the raceway surface, overstressing can cause problems such as denting.

The limit of this load is known as the "allowable axial load."

- The end of contact ellipse on the raceway surface reaches the shoulder of either an inner or outer ring.
- The contact stress on the raceway surface reaches 3 650 MPa in either the inner or outer ring raceway.

NTN, the maximum allowable load that does not cause such problems is defined as the "allowable axial load."

Note that the contact stress of 3 650 MPa on the raceway surface is a value that leads to a permanent deformation of 0.00002 to 0.00005 times as much as the rolling element diameter and has been determined through many years of experience.

The allowable axial load for each bearing is found in the associated dimensions table.

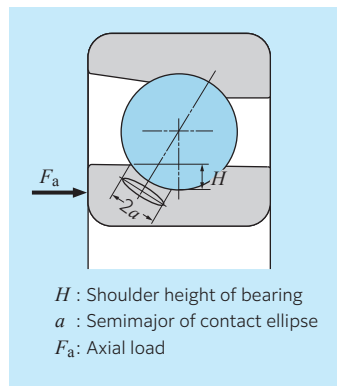

Fig. 3.10

4. Allowable Speed

High bearing speed leads to high temperature rise on the bearing owing to frictional heating within the bearing. When the temperature of the bearing exceeds a particular limit, the lubricant performance deteriorates significantly, possibly leading to bearing overheating or seizure.

The factors that can affect the maximum allowable bearing speed include:

- (1) Bearing type
- (2) Bearing size
- (3) Lubrication system (grease lubrication, air-oil lubrication, jet lubrication, etc.)
- (4) Internal clearance or preload on the bearing
- (5) Bearing arrangement (2-row to 5-row)
- (6) Bearing load
- (7) Accuracies of shaft, housing, etc.

The maximum allowable speeds listed in the bearing dimensions tables are reference values and are applicable only to individual bearings that are adequately lubricated and correctly preloaded under a condition where the heat is reliably removed from the bearing arrangement.

In the case of grease lubrication, these speeds are attainable only when the bearing is filled with an adequate amount of high-quality grease as given in Table 7.3, the bearing is sufficiently run in, and heat is removed by an arrangement such as a cooling jacket. In the case of oil lubrication, these speeds are attained only by an air-oil lubrication system if an adequate amount of ISO VG22 to 32 spindle oil is supplied and the heat is removed by an arrangement such as a cooling jacket. When using a large amount of lubricant, a jet lubrication system excels in lubrication and cooling performance, and can permit operation at the maximum allowable speed. However, this lubrication system involves a high power loss and should be employed carefully.

■ Speed factor of fixed position preloading

The bearing arrangements (2-row to 5-row) and speed reduction ratios (speed factors) for maximum allowable speed due to post-assembly preloads are summarized in Table 4.1.

The maximum allowable speed of a particular bearing can vary depending on the relation between heat generation and heat dissipation in the bearing as well as how well the bearing is lubricated.

Furthermore, to continue operation at high speeds and with varying preloads, it is recommended that bearings at the upper limit are multiplied by a factor of 0.8.

Table 4.1 Speed factor by bearing arrangement and preload

Bearing arrangement	Matching	GL	GN	GM
	DB	0.85	0.8	0.65
	DBT	0.7	0.6	0.5
	DTBT	0.8	0.75	0.6
	DTBTT	0.7	0.6	0.5

5. Bearing Arrangements and Structures of Bearings for Main Spindles

5.1 Bearing arrangement for main spindles

Typical examples of bearing arrangements for main spindles of machine tools are summarized in **Table 5.1**.

An optimal bearing arrangement must be determined through considerations about the properties required of the main spindle in question (maximum speed, radial and axial rigidities, main spindle size, required

accuracies, lubrication system, etc.). And, machine tool models incorporate built-in motor type main spindles. However, heat generation on a built-in motor can affect the accuracy of the main spindle and performance of lubricant, so a main spindle bearing should be selected very carefully.

Table 5.1 Typical examples of bearing arrangements for main spindles

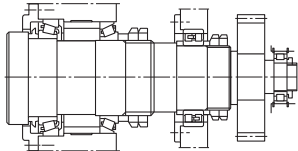
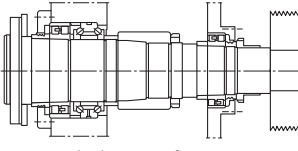
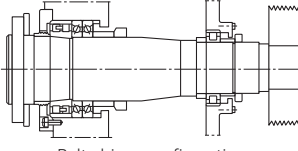
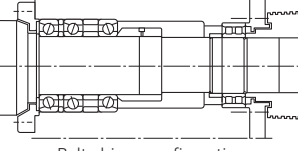
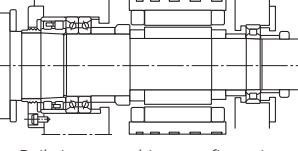
Bearing arrangement for main spindle	Bearing type	Typical applications
 Gear-driven configuration	[Type I] Tapered roller bearing + Tapered roller bearing + Double-row cylindrical roller bearing	Large turning machine Oil country lathe General-purpose turning machine Lubrication method ● Grease lubrication
 Belt-driven configuration	[Type II] Double-row cylindrical roller bearing + Double-direction angular contact thrust ball bearing + Double-row cylindrical roller bearing	CNC turning machine Machining center Boring machine Milling machine Lubrication method ● Grease lubrication
 Belt-driven configuration	[Type III] Double-row cylindrical roller bearing + High speed duplex angular contact ball bearing for axial load + Single-row cylindrical roller bearing NOTE: high speed variant of type II	CNC turning machine Machining center Milling machine Lubrication method ● Grease lubrication
 Belt-driven configuration	[Type IV] Duplex angular contact ball bearing (DBT arrangement) + Double-row cylindrical roller bearing NOTE: high speed variant of type II or III	CNC turning machine Machining center Milling machine Lubrication method ● Grease lubrication
 Built-in motor-driven configuration	[Type V] Double-row cylindrical roller bearing + High speed duplex angular contact ball bearing for axial load + Single-row cylindrical roller bearing NOTE: high speed variant of type III with built-in motor-driven configuration	CNC turning machine Machining center Milling machine Lubrication method ● Grease lubrication ● Air-oil lubrication

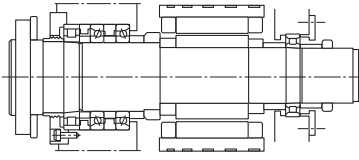
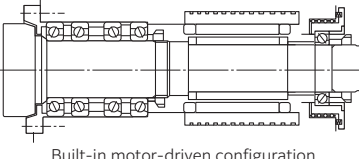
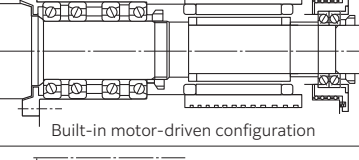
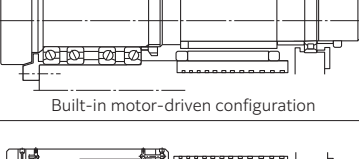
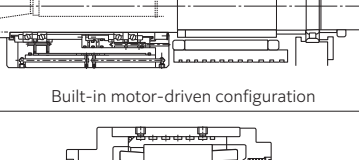
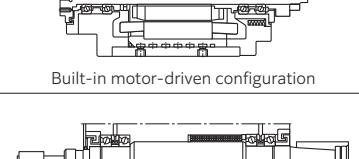

Bearing arrangement for main spindle	Bearing type	Typical applications
 Built-in motor-driven configuration	[Type VI] Single-row cylindrical roller bearing + High speed duplex angular contact ball bearing for axial load + Single-row cylindrical roller bearing NOTE: high speed variant of type V	CNC turning machine Machining center Lubrication method ● Grease lubrication ● Air-oil lubrication
 Built-in motor-driven configuration	[Type VII] Duplex angular contact ball bearing (DTBT arrangement) + Single-row angular contact roller bearing (w/ ball slide) NOTE: ultra high speed variant	Machining center <vertical> Lubrication method ● Grease lubrication ● Air-oil lubrication
 Built-in motor-driven configuration	[Type VIII] Duplex angular contact ball bearing (DTBT arrangement) + Duplex angular contact roller bearing (w/ ball slide) NOTE: ultra high speed variant	Machining center <vertical> Lubrication method ● Grease lubrication ● Air-oil lubrication
 Built-in motor-driven configuration	[Type IX] Duplex angular contact ball bearing (DTBT arrangement) + Single-row cylindrical roller bearing NOTE: ultra high speed variant	Machining center Lubrication method ● Grease lubrication ● Air-oil lubrication
 Built-in motor-driven configuration	[Type X] Adjustable preload bearing unit + Duplex angular contact ball bearing (DBT arrangement) + Single-row cylindrical roller bearing NOTE: high-rigidity/ultra high speed variant	Machining center Lubrication method ● Air-oil lubrication
 Built-in motor-driven configuration	[Type XI] Duplex angular contact ball bearing (DT arrangement) + Duplex angular contact ball bearing (DT arrangement)	Machining center Small turning machine Grinding machine Lubrication method ● Grease lubrication ● Air-oil lubrication
 Belt-driven configuration	[Type XII] Duplex angular contact ball bearing (DT arrangement) + Duplex angular contact ball bearing (DT arrangement)	Grinding machine Lubrication method ● Grease lubrication ● Air-oil lubrication ● Oil-mist lubrication

5.2 Bearing selection based on bearing arrangement for main spindle

An optimal bearing product that best suits the application is selected by referring to the bearing selection table in **Table 5.2**, which contains the possible bearing arrangements for main spindles.

- Designate the free side and fixed side.
- Select the bearing arrangement type (I to XII) on the free or fixed side.
- Select a set of bearing specifications applicable to the selected arrangement type.
- Choose a lubrication system suitable for the selected bearing specifications.
- Select a product group that satisfies the above-mentioned considerations.

Table 5.2 Bearing selection table

Fix side	Free side	Bearing specifications	Lubrication system	Applicable product groups		Considerations for selection procedure			
				Steel balls/ceramic balls					
Duplex angular contact ball bearing or adjustable preload bearing mechanism + Duplex angular contact ball bearing Bearing arrangement [Type IV, VII, VIII, IX, XI, or XII]	Single-row angular contact ball bearing or duplex angular contact ball bearing (w/ ball bush) Bearing arrangement [Type VII, VIII, XI, or XII]	Angular contact ball bearing for radial load Contact angle 30° or smaller	Sealed	[15°, 25°] 79 LLB/5S-79 LLB 70 LLB/5S-70 LLB [15°, 20°, 25°] 2LA-BNS9 LLB/5S-2LA-BNS9 LLB 2LA-BNS0 LLB/5S-2LA-BNS0 LLB	Bearing selection ① High speed performance (general) High ⇔ Low Contact angle 15°, 20°, 25°, 30° ② Rigidity • Radial rigidity High ⇔ Low Contact angle 15°, 20°, 25°, 30° • Axial rigidity Low ⇔ High Contact angle 15°, 20°, 25°, 30°, 40°, 60° • Complex rigidity (radial and axial)				
				[15°] 78C 72C [15°, 25°, 30°] 79U/5S-79U, 70U/5S-70U [15°, 20°, 25°] 2LA-HSE9U/5S-2LA-HSE9U 2LA-HSE0/5S-2LA-HSE0		Bearing arrangement [Type IV, VII, VIII, IX, XI, or XII]	Air-oil lubrication	Ultra high speed/dedicated air-oil lubrication series [25°] 5S-2LA-HSF0	High (4-row)  Medium (3-row)  Low (2-row) 
				Eco-friendly type [20°, 25°] 5S-2LA-HSL9U 5S-2LA-HSL0 5S-2LA-HSFL0 With re-lubricating hole on the outer ring [20°, 25°] 5S-2LA-HSEW9U 5S-2LA-HSEW0				③ Recommended arrangement 4-row (DTBT) or 2-row (DB) ④ Recommended lubrication specifications Standard main spindle: Grease High speed main spindle: Air-oil Low-noise: Grease or eco-friendly air-oil	
				Cylindrical roller bearing + Duplex angular contact ball bearing Bearing arrangement [Type II, III, V or VI]		Double-row cylindrical roller bearing or single-row cylindrical roller bearing Bearing arrangement [Type I, II, III, IV, V, VI, IX or X]	Cylindrical roller bearing		Grease lubrication
Single-row N10HS/N10HSK N10HSRT6/N10HSRT6K									
Tapered roller bearing + Cylindrical roller bearing Bearing arrangement [Type I]	Cylindrical roller bearing	Angular contact ball bearing for axial load Contact angle less than 60°	Grease lubrication	[30°] HTA9UA HTA0UA/5S-HTA0UA [40°] HTA9U HTA0U/5S-HTA0U [60°] 5629/5629M 5620/5620M					
		Thrust contract ball bearing							
		Cylindrical roller bearing	Oil lubrication	Grease lubrication 329XU 4T-320X/320XU Inch series tapered roller bearing					

5.3 Adjustable preload bearing unit

A recent trend in the machine tool industry is a steady increase of operating speeds. The maximum $d_m n$ value [pitch circle diameter across rolling elements d_m (mm) multiplied by speed n (min^{-1})] reached by main spindles with air-oil lubricated lubrication can be as high as 2.5 to 3.8×10^6 . At the same time, main spindles are requiring increased rigidity. Therefore, main spindle bearings must be capable of both high speed operation and high rigidity. This can be achieved through optimal preloading.

A fixed preload (spring preload) system is usually employed to satisfy both these high speed and high rigidity requirements. A spindle unit with fixed-position preload that is adjustable for different speed conditions is advantageous for optimizing the rigidity of the unit.

The **NTN Adjustable Preload Bearing Unit** is a high speed, high-rigidity unit that features fixed position preload that can be adjusted for different speed conditions.

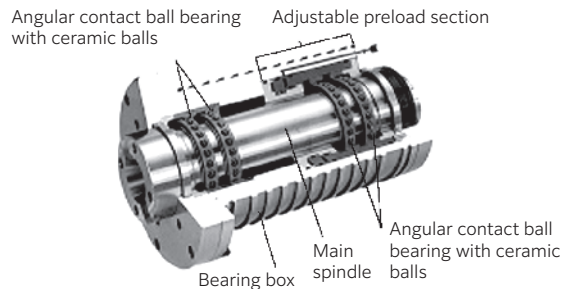

Fig. 5.1 Adjustable preload bearing unit

The **NTN Adjustable Preload Bearing Unit** is illustrated in **Fig. 5.1**. Hydraulic pressure is used to shift the position of the adjustable preload sleeve situated in the rear bearing section of the unit. This changes the preload on the bearings.

A spindle incorporating a 3-step adjustable preload bearing unit is illustrated in **Fig. 5.2**. The sleeve in the adjustable preload section is comprised of two hydraulic pressure chambers, A and B, as well as a spiral groove for sliding motion. The preload can be adjusted to one of three settings by changing the hydraulic pressure in each of the chambers. To achieve instantaneous and reliable adjustment, high-pressure oil (at the same pressure as in the hydraulic chambers) is supplied to the spiral groove on the outside of the sleeve. This oil provides lubrication so that the sleeve can move smoothly.

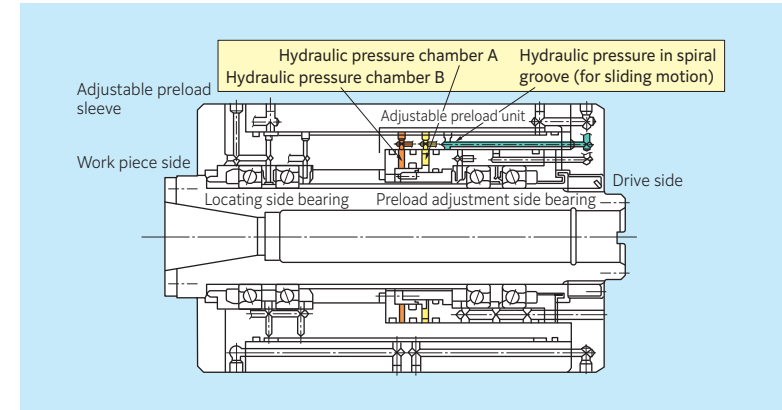

Fig. 5.2 Typical spindle configuration incorporating 3-step Adjustable Preload Type Bearing Unit

■ Operating mechanism

Fig. 5.3 shows the hydraulic operation of the unit for three preloading conditions as well as the associated motion of the adjustable preload sleeve.

• Low speed operation (heavy preload): Chamber A is pressurized.

Component ① moves to the right by a preset clearance L_1 and contacts Component ②. The axial clearance is δ_1 [see **Fig. 5.3 (a)**].

• Medium speed operation (medium preload): Chamber B is pressurized.

Components ① and ③ move to the right by a preset clearance L_2 , causing Component ③ to contact Component ④. The axial clearance is δ_2 [see **Fig. 5.3 (b)**].

• High speed operation (light preload): Chambers A and B are not pressurized.

Components ① and ③ return ¹⁾ to the left due to the reaction force on the bearing. This causes Component ③ to contact Component ⑤, thereby returning the axial clearance to the initial setting of δ_3 [see **Fig. 5.3 (c)**].

1) The return motion of the components ① and ③ is achieved by the reaction force of bearing or a separately provided spring.

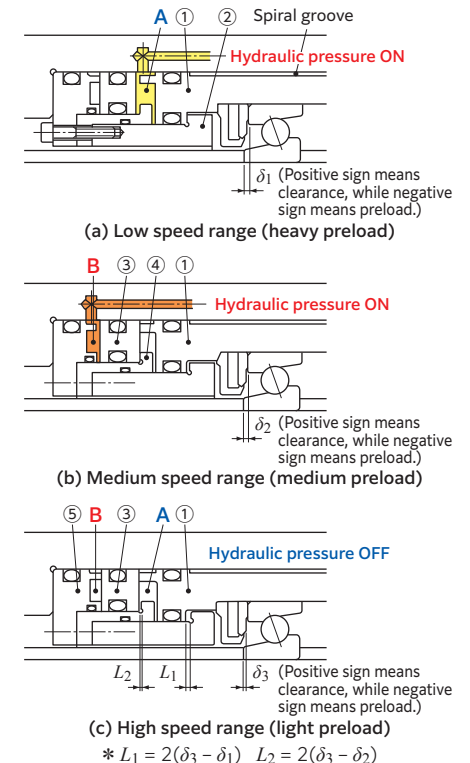

Fig. 5.3 Operating mechanism of Adjustable preload

5.4 Bearing jacket cooling system

With a built-in motor drive system, the main spindle is directly driven by a motor and is therefore suitable for rapid acceleration or deceleration. However, this system can be adversely affected by temperature rise. A cooling jacket with a spiral groove around the housing allows cooling oil to flow through the unit.

If heat generated by the motor affects the bearing, overheating of the bearing as well as degradation of the grease can occur.

■ Considerations about cooling of jacket

A typical bearing arrangement is shown in Fig. 5.4 and Fig. 5.5, comprising a double-

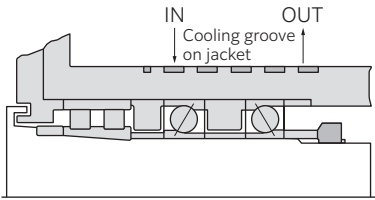

Fig. 5.4 Inadequate cooling groove on jacket

row cylindrical roller bearing and an angular contact ball bearing set. The cooling groove on the jacket in Fig. 5.4 starts at around an area above the angular contact ball bearings and does not cool the double-row cylindrical roller bearing effectively (The fit of the angular contact ball bearings with the bore of the housing is a loose fit, the bearings are not in direct contact with the housing). In the configuration in Fig. 5.5, the cooling groove extends to the region above the double-row cylindrical roller bearing, and cools both the angular contact ball bearings and the double-row cylindrical roller bearing effectively.

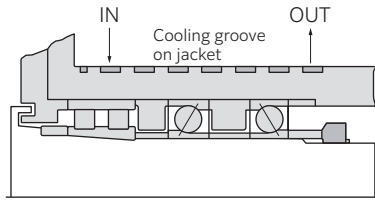

Fig. 5.5 Adequate cooling groove on jacket

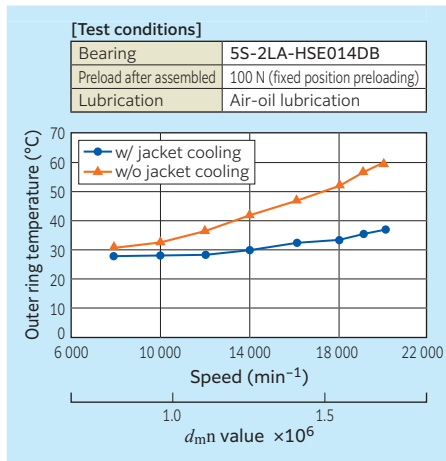

Fig. 5.6 Variation in bearing temperature depending on presence/absence of jacket cooling (angular contact ball bearing)

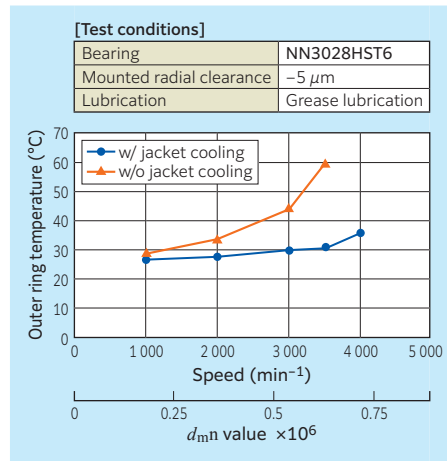

Fig. 5.7 Variation in bearing temperature depending on presence/absence of jacket cooling (cylindrical roller bearing)

6. Handling of Bearings

6.1 Cleaning and filling with grease

To achieve maximum speed and limited temperature rise with a precision rolling bearing, it is vital to handle the bearing correctly.

The handling of bearings involves cleaning, drying, filling with grease (if necessary), and the running-in operation. For each step, follow the precautions and instructions.

A sealed bearing contains prefilled grease. Do not clean (rinse) and dry this type of bearing. Only wipe away rust-preventive oil with a clean cloth before assembling the bearing.

■ Cleaning (removal of rust-preventive oil)

- Immerse the bearing in kerosene or a highly volatile solvent such as naphthosol and wash it turn the by hand. Then remove the kerosene using benzene or alcohol. Use clean compressed air to blow away the rinsing fluid.
(For air-oil lubrication, it is recommended that after cleaning, the bearing should either be coated with the application specific lubricant or a less viscous oil)

■ Drying

If the bearing is to be used with grease lubrication, it is necessary to thoroughly dry the bearing to avoid leakage of grease. After drying, be sure to immediately fill the bearing with grease.

Drying can be performed by blowing hot air onto the bearing or placing the bearing in a chamber at constant temperature. When drying by hot air, be sure to consider the cleanliness of the air.

■ Filling with grease



The procedures for greasing ball and roller bearings can be found below.

After filling with grease, turn the bearing by hand to uniformly distribute the grease to the whole rolling surface.

<Ball bearings> See Table 6.1

- By using an injector or small plastic bag, fill grease between balls in equal amounts, aiming at the inner ring rolling surface.
- For a bearing with a ring-guided cage, also apply grease to the guide surface of the cage using a spatula or similar tool.

Table 6.1 Filling grease into angular contact ball bearing



	By using an injector, fill grease between balls in equal amounts, aiming at the rolling surface of the inner ring. Apply grease to the guide surface as well for outer ring guide cages.
	[After completion of filling]
	Turn the bearing by hand while applying an appropriate load in the contact angle direction so that the any area in the interior of bearing is sufficiently lubricated with grease. When doing so, check that the grease adheres to the surface of the balls.

- If grease cannot be filled into the inner ring rolling surface because of a small gap between the cage and the inner ring add grease to the outer ring rolling surface. In this case, carefully turn the bearing so that the grease is fully spread on the inner ring side.

<Roller bearings> See Table 6.2

- Apply grease to the outer (inner) side of rollers, and while turning the rollers with fingers, spread the grease to the inner ring side.

Table 6.2 Filling grease into cylindrical roller bearing

	Apply grease to the outer circumference surface of cage.
	Spread the grease over the roller outer diameter surface. Apply grease to the bearing rollers and rotate by hand to coat the inner ring surface. Ensure that grease will coat the pocket, mating, and roller end surfaces of the cage.
	[After applying grease] If a lump of grease remains on the cage rib outside diameter surface, the running-in operation can take a longer time. Apply the grease to the outer diameter surface of the cage ribs. Use fingers to coat the surface towards the roller ends (see photo on left).

■ Running-in operation

(1) Air-oil or oil-mist lubrication

The running-in operation is relatively simple with oil lubrication because no peak temperature occurs and the bearing temperature stabilizes within a relatively short time. NTN recommends that the speed of bearing is to be increased in steps of 2 000 to 3 000 min⁻¹ until the maximum speed is reached.

Every speed setting should be maintained for about 30 minutes. However, for the speed range where the $d_{m,n}$ value (pitch circle diameter across rolling elements multiplied by speed) exceeds 1.0×10^6 , increase the bearing speed in steps of 1 000 to 2 000 min⁻¹ to ensure the stable running.

(2) Grease lubrication

For a grease-lubricated bearing, a running-in operation is very important in attaining stable temperature rise. During a running-in operation, a large temperature rise (peak) occurs while the bearing speed is increased, and then the bearing temperature eventually stabilizes. Refer to the section "6.12 Running in operation for main spindle bearing."

<Ball bearings>

NTN recommends that the bearing speed be increased in steps of 1 000 to 2 000 min⁻¹ and be further increased only after the temperature has stabilized at the current speed setting.

However, for the speed range where the $d_{m,n}$ value exceeds 0.4×10^6 , increase the bearing speed in steps of 500 to 1 000 min⁻¹ to ensure the stable running.

<Roller bearings>

Compared with contact ball bearings, the time to peak temperature or saturation in running-in operation of roller bearings tends to be longer. Also, there will be temperature rise due to whipping of the grease and the temperature rise may be unstable. To cope with this problem, run the roller bearing in the maximum speed range for a prolonged period.

Increase the bearing speed in steps of 500 to 1 000 min⁻¹ only after the bearing temperature has stabilized at the current speed setting.

For the speed range where the $d_{m,n}$ value exceeds 0.3×10^6 , increase the bearing speed in steps of 500 min⁻¹ to ensure safety.

6.2 Mounting

When mounting a bearing to a main spindle, follow either of the mounting techniques described below:

- (1) Press-fitting with hydraulic press
- (2) Mounting by heating bearings

With either technique, it is important to minimize the adverse effects of the mounting process to maintain bearing accuracy.

(1) Press-fitting with hydraulic press

Before press-fitting a bearing with a hydraulic press or hand press, the press-fitting force due to the interference between the shaft and inner ring must be calculated. A hydraulic press having a capacity greater than the required press-fitting force must be used. Next, using an inner ring press-fitting jig, the inner ring is correctly press-fitted to the shoulder of shaft. Please be careful not to exert a force on the outer ring (see Fig. 6.1).

After the press-fitting operation, it is important to measure the accuracies of various portions of the bearing to verify that the bearing has been correctly mounted to the shaft. When using a multi row bearings, measure the runout after assembly and correct misalignment across the outer rings as necessary (see Fig. 6.2 and Fig. 6.3).

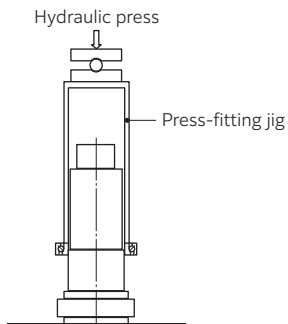

Fig. 6.1 Press-fitting pressure

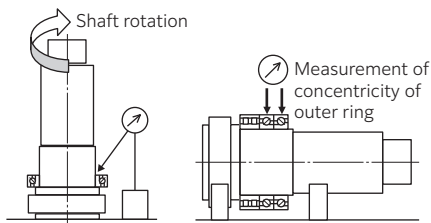

Fig. 6.2 Checking for face runout of inner ring

Fig. 6.3 Checking for concentricity of outer ring

■ Calculation of press-fitting force

The press-fitting force occurring from the interference between the shaft and inner ring can be determined by the formula given below.

According to the calculated press-fitting force, a hydraulic press having a sufficiently large capacity must be used to mount the bearing. The variations in dimensional errors among the bearings should be considered. The force needed to press the inner ring to the shaft can be obtained with the following formula (6.1).

Force to press-fitting inner ring to shaft

$$K_d = \mu \cdot P \cdot \pi \cdot d \cdot B \dots\dots\dots (6.1)$$

Where:

- K_d : Force for press-fitting or extracting an inner ring, N
- P : Surface pressure on fitting surface, MPa (see Table 6.3)
- d : Shaft diameter, inner ring bore diameter, mm
- D : Outer ring outside diameter, mm
- B : Inner ring, width
- μ : Sliding friction coefficient (when press-fitting inner ring over cylindrical shaft: 0.12)

Table 6.3

Fitting conditions and calculation formulas		Symbol (Unit: mm)
Fitting surface pressure MPa	Fits between solid steel shaft and inner ring $P = \frac{E}{2} \frac{\Delta_{def}}{d} \left[1 - \left(\frac{d}{D_i} \right)^2 \right] \dots\dots\dots (6.2)$	d : Shaft diameter, inner ring bore diameter d_0 : Hollow shaft bore diameter D_i : Inner ring average raceway diameter
	Fits between hollow steel shaft and inner ring $P = \frac{E}{2} \frac{\Delta_{def}}{d} \frac{[1 - (d/D_i)^2][1 - (d_0/d)^2]}{[1 - (d_0/D_i)^2]} \dots\dots (6.3)$	Δ_{def} : Effective interference E : Modulus of longitudinal elasticity = 208 000 MPa

$$\Delta_{def} = \frac{d}{d+2} \Delta d \dots\dots\dots (6.4)$$

(In the case of a ground shaft)

Δd : Theoretical interference fitting, μm

$$D_i = 1.05 \frac{4d + D}{5} \dots\dots\dots (6.5)$$

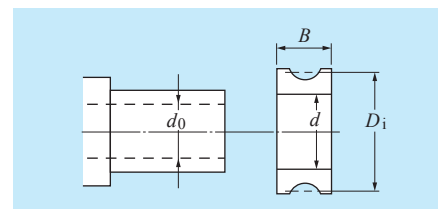

Fig. 6.4

<Example of calculation for press-fitting force>

The calculation for press-fitting force for tight fit of 2 μm interference between the shaft and inner ring for the standard angular contact ball bearing is as summarized below:

- 7020UC ($\phi 100 \times \phi 150 \times 24$)
- Interference fit of 2 μm (solid shaft)

$$\Delta_{def} = \frac{100}{102} \times 0.002 = 0.00196$$

$$D_i = 1.05 \times \frac{4 \times 100 + 150}{5} = 115.5$$

$$P = \frac{208\,000}{2} \times \frac{0.00196}{100} \left[1 - \left(\frac{100}{115.5} \right)^2 \right] = 0.51 \text{ MPa}$$

$$K_d = 0.12 \times 0.51 \times \pi \times 100 \times 24 = 460 \text{ N}$$

To accommodate for variation in the friction, incorporate a safety factor of 2 to 3. As a result, the required press-fitting force is:

$$460 \times (2 \text{ to } 3) = 920 \text{ to } 1\,380 \text{ N}$$

(2) Mounting by heating bearings

When mounting a bearing to a shaft using a constant temperature chamber, bearing heater or the like, follow the instructions below.

Heat the bearing at a temperature that reflects the interference between the shaft and inner ring (see Fig. 6.5).

Assuming linear expansion coefficient 12.5×10^{-6} , heating temperature ΔT , inner ring bore diameter ϕd , and interference fit $\delta = 12.5 \times 10^{-6} \times d \times \Delta T$
 Ex.) If $\phi d = 100$ mm, and $\delta = 0.030$ (30 μm , tight fit), then the required heating temperature $\Delta T = 24$ °C.

Therefore, the bearing temperature is heated to approximately room temperature +30 °C to allow for cooling during assembly.

NOTE

- If a resin material is used for the cage of angular contact ball bearing, do not excessively heat the bearing (approx. 80 °C max.).
- As a result of heating bearings after cooling, the inner ring will axially shrink, and there will be clearance between the bearing side face and shaft shoulder (see Fig. 6.6). For this reason, keep the bearing and shaft forced together with a press or the like after the unit returns to normal temperature. After cooling, check that the bearing is mounted to the shaft correctly.
- When using a bearing heater, be sure to avoid overheating. To prevent bearing from being magnetized, use equipment that has a demagnetizing feature.

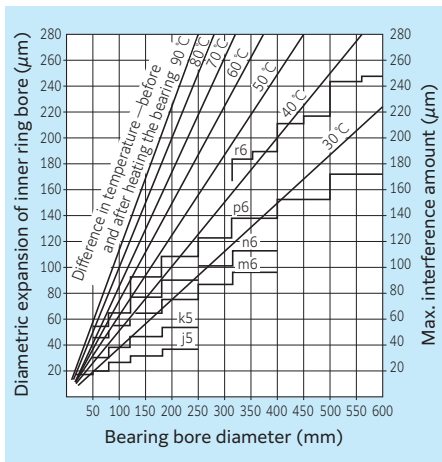

Fig. 6.5 Required heating temperature for mounting by heating inner ring

Remarks: The maximum interference amounts are interference values associated with Class 0 bearings.

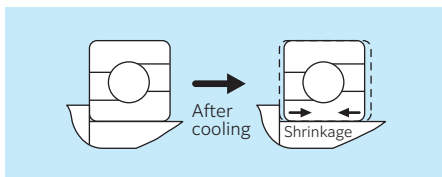

Fig. 6.6 Cooling after mounting by heating bearings

6.3 Tightening of inner ring

When mounting and securing a bearing to a main spindle, the inner ring side face is usually clamped with a stepped sleeve or precision bearing nut, and the front cover situated on the outer ring side face is bolted down. When utilizing a stepped sleeve or precision bearing nut to clamp the inner ring, the following precautions must be followed.

■ Tightening with stepped sleeve

The stepped sleeve is designed that the hydraulically expanded sleeve is inserted over the shaft, and a predetermined drive-up force (tightening force) is applied to the shaft. Then the hydraulic pressure is released in order to secure the sleeve onto shaft and provide a tightening force to the bearing. This technique is a relatively simple locking method (see Fig. 6.7).

Note however after being locked in position by interference with the shaft, the sleeve can come loose because of deflection of the shaft or a moment load applied to the shaft.

For this reason, in many cases, a stepped sleeve is used together with a bearing nut as illustrated in Fig. 6.8.

■ Tightening with precision bearing nut

Required tightening force is achieved with the precision bearing nut (precision locknut) by correctly controlling the tightening torque.

Note that when a bearing has been locked with a precision bearing nut (lock nut), the nut can develop inclination owing to the clearance on the threaded portions. If this problem occurs, fine adjustment will be necessary to obtain necessary running accuracy for the shaft.

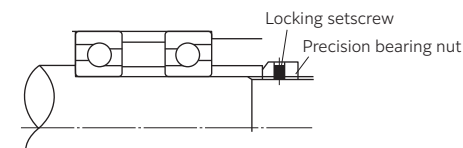

Fig. 6.9 Tightening with precision bearing nut

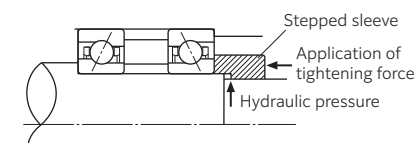

Fig. 6.7 Tightening with stepped sleeve

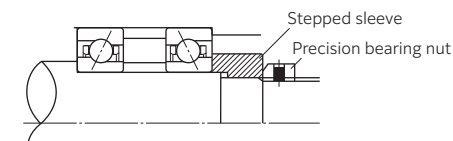

Fig. 6.8 Tightening with stepped sleeve + precision bearing nut

■ Correlation between tightening torque and tightening force with precision bearing nut

The correlation between tightening torque and tightening force with a precision bearing nut can be defined with the formula given below.

Because the thread face of the precision bearing nut, the thread face of the shaft and the bearing surface and nut constitute sliding surfaces, the correlation between tightening torque and tightening force will vary depending on the friction coefficient. Therefore, the nut needs to be thoroughly run on the shaft thread in advance to ensure smooth and uniform tightening.

It is also necessary to determine the correlation between tightening torque and tightening force by using a load washer or the like in advance.

$$F = \frac{M}{(d/2) \tan(\beta + \rho) + r_n \mu_n} \dots\dots\dots (6.6)$$

F : Precision bearing nut tightening force, N
 M : Precision bearing nut tightening torque, N · mm

d : Effective diameter of thread, mm
 ρ : Friction angle of thread face

$$\tan \rho = \frac{\mu}{\cos \alpha} \dots\dots\dots (6.7)$$

β : Lead angle of thread, °
 $\tan \beta = \text{number of threads} \times \text{pitch} / \pi d$
 (6.8)

r_n : Average radius of nut surface, mm
 μ_n : Friction coefficient of nut surface
 $\mu_n \cong 0.15$
 μ : Friction coefficient of thread face
 $\mu \cong 0.15$
 α : Half angle of thread, °

<Example calculation>

- Precision bearing nut
AN20 (see Fig. 6.10)
- Thread data
M100 × 2 (Class 2 thread)
Effective diameter
 $d = \phi 98.701$ mm
Half angle of thread $\alpha = 30^\circ$

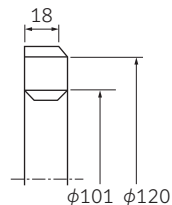

Fig. 6.10

The correlation between a tightening torque and tightening force with the precision bearing nut can be calculated as follows:

$$\tan \rho = \frac{0.15}{\cos 30^\circ} \quad \rho = 9.826^\circ$$

$$\tan \beta = \frac{1 \times 2}{\pi \times 98.701} \quad \beta = 0.370^\circ$$

$$r_n = \frac{(101 + 120)/2}{2} = 55.25$$

$$F = \frac{M}{\frac{98.701}{2} \tan(0.370 + 9.826) + 55.25 \times 0.15} = \frac{M}{17.163}$$

6.4 Elastic deformation of spacer by tightening force

When incorporating a bearing into a main spindle, the bearing must be correctly forced into a predetermined position and maintained with a predetermined bearing pressure in order to maintain appropriate accuracies, clearances and rigidities of the bearing and main spindle.

When axially locating a duplex angular contact ball bearing by using a bearing spacer the cross-sectional area of spacer as well as (depending on the tightening force) the bearing pressure and elastic deformation by tightening of the spacer must be considered.

■ Correlation between inner ring spacer tightening force and amount of elastic deformation

When securing an angular contact ball bearing onto a main spindle, the bearing inner ring is tightened and locked by the shoulder of main spindle and a precision bearing nut and/or stepped sleeve. This inner ring tightening force causes the spacer to develop elastic deformation in the axial direction, varying the axial clearance on the bearing. In the case of a back-to-back duplex bearing (DB, DTBT or DBT) for a main spindle in particular, the inner ring tightening force will decrease the bearing clearance, estimated leading to an increased post-assembly preload and operating preload. A possible inner ring tightening force-derived axial deformation can develop in the form of deformation of both the inner ring and inner ring spacer. NTN's experience has shown that only the elastic deformation on inner ring spacers needs to be considered.

The amount of deformation of a spacer is calculated using the following formula:

$$\delta = \frac{P \times L}{A \times E} \dots\dots\dots (6.9)$$

δ : Elastic deformation, mm
 P : Inner ring tightening force, N
 L : Inner ring spacer width, mm
 A : Inner ring cross-sectional area, mm²
 E : Young's modulus 208 000, MPa

The require tightening force exerted onto inner ring spacers varies depending on the bearing manufacturer. From its experience, NTN adopts the typical values listed in Table 6.4 (refer to next page).

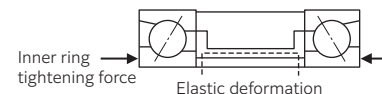

Fig. 6.11 Elastic deformation of inner ring spacer

Table 6.4 Nut tightening force

Bearing bore diameter (mm)	Nut tightening force (N)	Nut tightening torque <reference value> (N · m)	Front cover drive-up (mm)	
6	1 470	2	0.01-0.02	
8		2		
10		4		
12	2 200	5		
15		8		
17		9		
20	2 940-4 900	10-17		
25		13-22		
30		15-26		
35		18-30		
40		34-68		
45	4 900-9 800	38-75		
50		42-83		
55		92-138		
60	9 800-14 700	100-150		
65		108-162		
70		116-174		
75		124-186		
80		199-331		
85		211-351		
90		223-372		
95	14 700-24 500	235-392		
100		247-412		
105		259-432		
110		271-452		
120		295-492		
130	24 500-34 300	319-532		
140		572-800		
150		613-858		
160		655-917		
170		695-973		
180		736-1 031		
190		779-1 090		
200		818-1 145		
220		<reference value> (34 300-44 100)	—	
240			—	
260	—			
280	—			
300	—			
				0.02-0.03

- Note 1) **NTN** has specified the nut tightening forces in this table based on experiences. However, **NTN** has no production record for bore diameter of 220 mm or larger. The nut tightening forces listed are only to be used for reference.
- The nut tightening torque is calculated with a friction coefficient of 0.15 between the nut seating face and screw thread surface.
 - When tightening nuts, it is recommended to tighten them to twice the set value, then loosen them, and finally re-tighten them to the recommended set value.
 - For ball screw support bearings (BST), a tightening force approximately 2 to 3 times as large as the preload is recommended. The values shown in **Table 6.4** are also recommended for front arrangement bearings (DF, DTFT).

6.5 Front cover drive-up

When mounting and securing a bearing onto a main spindle, the inner ring is usually tightened with a stepped sleeve or precision bearing nut and the outer ring side is bolted down. When locking the outer ring with a front cover, the following points need to be considered.

■ Front cover pressing amount

The bearing outer ring is tightened and locked between the shoulder of the housing and front cover at the main spindle front section. The front cover is installed by utilizing bolt holes (6 to 8 positions) on its flange. The usual pressing allowance on the outer ring and the front cover, which **NTN** has adopted through experience, falls in a range of 0.01 to 0.02 mm. Too large a pressing amount on the outer ring or a smaller number of fastening bolts may lead to poor roundness of the bearing ring.

Typical fit and deterioration in roundness of a raceway surface resulting from a pressing amount of 0.05 mm on the outer ring are shown in **Fig. 6.14**. Also, typical outer ring pressing amount and deterioration of a raceway surface with a fit of 5 μm loose are provided in **Fig. 6.15**.

To avoid deformation of the outer ring raceway surface, **NTN** recommends that the outer ring be installed to a highly accurate housing in transition fit with a large number of bolts.

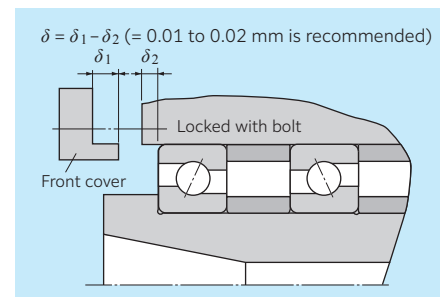
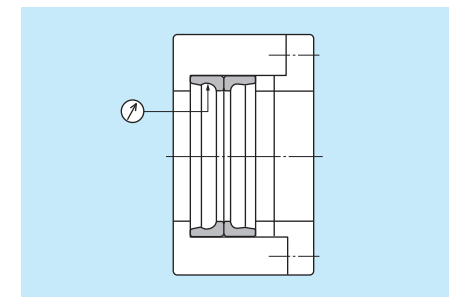
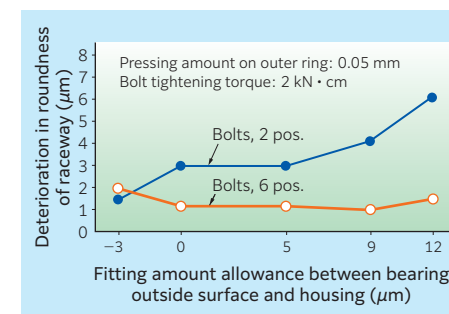
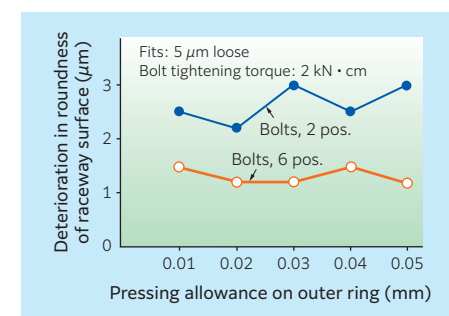
Fig. 6.12 Front cover pressing allowance

Fig. 6.13 Measuring position for roundness on outer ring raceway surface

Fig. 6.14 Effect of fit of outer ring on roundness of raceway surface

Fig. 6.15 Pressing allowance on outer ring vs. deterioration in roundness of raceway surface

6.6 Checking axial rigidity

In the typical method for checking for the axial rigidity of a bearing installed to a machine tool, the main spindle itself is pushed with a push-pull gauge to measure the resultant axial displacement. A method using a dial gauge is described below.

Two dial gauge are placed on two locations (axisymmetric locations separated by 180°) at the leading end of the main spindle. Use magnetic stands to secure the dial gauge to the end face of housing. Then, apply the load onto the main spindle and the resultant axial displacement is measured.

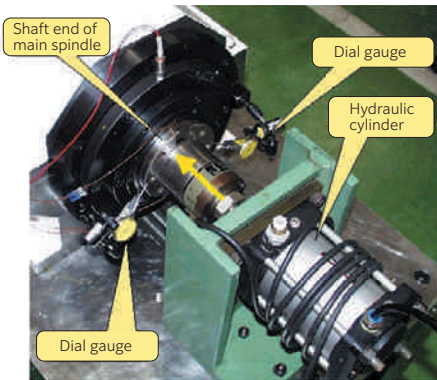

Photo 6.1

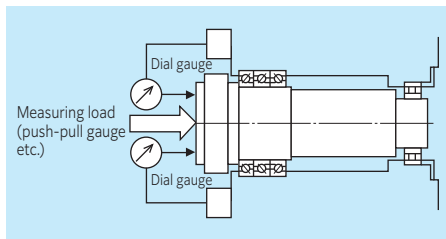

Fig. 6.16 Checking for axial rigidity

6.7 Clearance adjustment for cylindrical roller bearing

When incorporating a cylindrical roller bearing into a main spindle of a machine tool such as an NC turning machine or machining center, and setting the internal clearance to zero or to a negative clearance, the inner ring of the bearing usually has a tapered bore.

The internal clearance is adjusted by fitting the tapered bore bearing onto the tapered portion of the main spindle and driving the bearing in the axial direction to expand the inner ring.

For adjusting the internal clearance, two methods are available: a method consisting of clearance measurement for each bearing and adjustment with a spacer (s), and a mounted internal clearance adjustment gauge.

■ Method with clearance measurement and adjustment with spacer (s)

Adjust the bearing internal clearance by following the procedure described below:

(1) Calculation of outer ring shrinkage (see Fig. 6.17)

Calculate the interference at the fitting area Δ_{deff} between the outer ring and housing.

Measure the housing bore diameter first, and then calculate the interference Δ_{deff} from the outer ring outside diameter listed on the bearing inspection sheet.

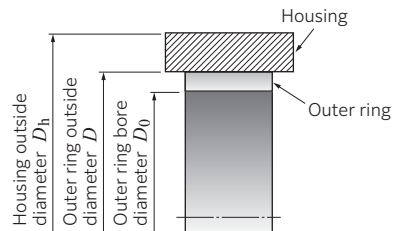

Fig. 6.17 Fits of outer ring and housing

EX. 1

Bearing outer ring outside diameter $\phi 150$ mm (Inspection sheet = -0.005)
 Housing bore diameter D $\phi 150$ mm (measurement value = -0.007)
 Interference at fitting area $\Delta_{deff} = 0.002$ ($2 \mu\text{m}$ tight)
 • Calculate the outer ring shrinkage ΔG with the formula (6.10).

$$\Delta G = \Delta_{deff} \cdot \frac{D_0}{D} \cdot \frac{1 - (D/D_h)^2}{1 - (D_0/D)^2 \cdot (D/D_h)^2} \dots\dots\dots (6.10)$$

EX. 2

Housing outside diameter $D_h = \phi 200$, outer ring outside diameter $D = \phi 150$, outer ring bore diameter $D_0 = \phi 137$

$$\Delta G = 0.002 \cdot \frac{137}{150} \cdot \frac{1 - (150/200)^2}{1 - (137/150)^2 \cdot (150/200)^2} = 0.0015 \dots\dots\dots (6.11)$$

(2) Measurement of bearing position and bearing radial clearance on a temporarily mounted bearing

• Mount the bearing inner ring with the cage and rollers onto the tapered shaft (see Fig. 6.18).

In this process, force the inner ring until its tapered bore face is fully seated, and then measure the distance between the shaft shoulder and inner ring side face (L_1).

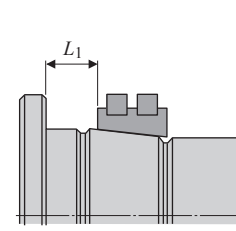

Fig. 6.18 Measurement of bearing position

NOTE: After mounting the inner ring, check that the bearing side face is square to the main spindle centerline.

- At this point, mount the outer ring, move the outer ring up and down by hand and then measure the internal clearance after mounting (Δr_1) (see Fig. 6.19).
- Calculate the estimated bearing clearance Δ_1 after press-fitting the outer ring into the housing with the formula (6.12). The result of the calculation reflects the outer ring shrinkage ΔG .

$$\Delta_1 = \Delta r_1 - \Delta G \dots\dots\dots (6.12)$$

EX. 3

Internal clearance after mounting $\Delta r_1 = 0.030$
 Outer ring shrinkage $\Delta G = 0.0015$
 Estimated bearing clearance $\Delta_1 = 0.030 - 0.0015 = 0.0285$

(3) Adjustment of spacer width between shaft shoulder and inner ring

To adjust the bearing clearance to a predetermined target value (δ) after mounting, determine the spacer width L_n with the formula (6.13) (see Fig. 6.20 and Fig. 6.21).

$$L_n = L_1 + f(\delta - \Delta_1) \dots\dots\dots (6.13)$$

(n = 2, 3, 4 ...)

The value f in the formula (6.13) is found in the Table 6.5 (refer to next page).

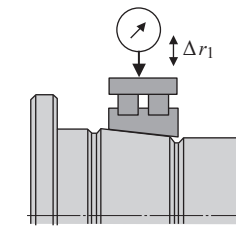

Fig. 6.19 Measurement of bearing radial clearance

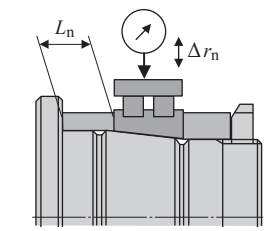

Fig. 6.20 Clearance measurement after insertion of spacer

Table 6.5 Value f

Value d_m/d_i	Value f
0 -0.2	13
0.2-0.3	14
0.3-0.4	15
0.4-0.5	16
0.5-0.6	17
0.6-0.7	18

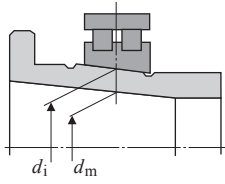

Fig. 6.21 Explanation of d_m/d_i

EX. 4

In the case of NN3020K, if bearing bore diameter $d = \phi 100$, width $B = 37$, and $d_i = d + 1/12 \cdot B/2$, then $d_i = \text{dia. } \phi 101.5417$.

If the targeted post-mounting clearance value $\delta = 0.015$, $L_1 = 15$, $d_m = \phi 60$, $\Delta_1 = 0.0285$, then $d_m/d_i = 60/101.5417 = 0.5909$, and, therefore, $f = 17$.

Thus, the spacer width L_n between the shoulder and inner ring equivalent to $\delta = 0.015$ will be the value shown by the formula below:

$$L_n = 15 + 17 \times (0.015 - 0.0285) = 14.7705$$

(4) Bearing clearance measurement after insertion of spacer (see Fig. 6.20)

Insert a spacer that satisfies the spacer width L_n between the shoulder and inner ring determined in the previous step, and tighten the inner ring until the spacer does not move. Next, move the bearing outer ring up and down by hand and measure the internal clearance after mounting (post-mounting internal clearance) Δr_n . The estimated bearing clearance Δ_n after press-fitting of the outer ring into the housing is determined with the formula below:

$$\Delta_n = \Delta r_n - \Delta G \dots\dots\dots (6.14)$$

($n = 2, 3, 4 \dots$)

(5) Final adjustment for spacer width

- Repeat the steps (3) and (4) above to gradually decrease the spacer width L_n so as to adjust the post-mounting bearing clearance to the targeted clearance.
- By plotting the correlation between the spacer width and post-mounting clearance as illustrated in Fig. 6.22, the spacer width for the final targeted clearance will be more readily obtained.

- Positive clearance: All rollers are sliding rather than rolling.
- Clearance = 0: About half of the rollers are rolling but the rest are sliding.
- Negative clearance: All rollers are rolling.

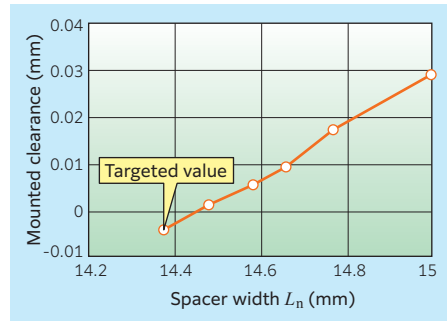

Fig. 6.22 Correlation between spacer width L_n and mounted clearance Δ_n

■ Method using mounted internal clearance adjustment gauge

The mounted internal clearance adjustment gauge has a cylindrical ring, which has a cut-out so that the ring can be opened and closed. The bore surface of the ring is used as a location for measurement. The clearance at the location for measurement is proportional to the reading on the dial gauge. As illustrated in Fig. 6.23, the mounted internal clearance adjustment gauge consists of a ring gauge, dial gauge, and attachment components. Its fixture protects the interference gauge against possible deformation when not in use. For the measuring operation, detach the fixture.

● Usage of mounted internal clearance adjustment gauge

(1) Measurement of outer ring raceway diameter (bore diameter)

- Mount the outer ring into the housing. (For easy mounting, heat the housing.)
- Wait until the temperature of the outer ring is same as that of the inner ring, and then measure the outer ring raceway diameter (bore diameter). Take measurements at several points and calculate the average, and then zero the gauge at this average value (see Photo 6.2).

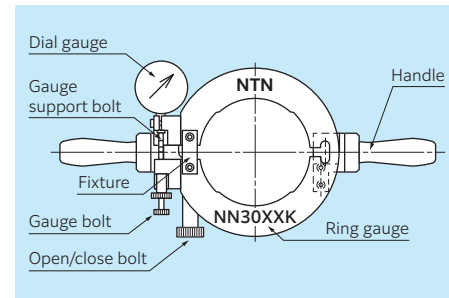

Fig. 6.23 Descriptions of various components on mounted internal clearance adjustment gauge



Photo 6.2

(2) Setup of mounted internal clearance adjustment gauge

- Place the cylinder gauge, onto the bore surface of clearance adjustment gauge as shown in **Photo 6.3**, and adjust it with the open/close bolt so that its Dial 1 is set to zero.
- When the reading of Dial 1 of the cylinder gauge is zero, adjust the gauge bolt so that the pointer of Dial 2 points at the red mark (correction amount of the gauge) (see **Photo 6.4**).

With the gauge bolt, adjust the gauge so that the short pointer is situated at the scale 2 position (With the large size, insert the pin into the hole of the open/close bolt and make fine-adjustment).

NOTE 1) **Photo 6.4** shows the inner ring and rollers. When the correction amount of the gauge is adjusted, adjust it only with the thickness gauge.

NOTE 2) The pointer of Dial 2 is directed to the red mark. The purpose of this is to compensate clearance error caused due to the structure of mounted internal clearance adjustment gauge. The correction amount can vary from gauge to gauge.

NOTE 3) When the pointer of Dial 2 is in line with the red mark, the zero reading on Dial 2 coincides with the zero bearing clearance.

(3) Setting up the mounted internal clearance adjustment gauge on the main spindle

- Mount the cage and roller with inner ring onto the main spindle, and lightly tighten the precision bearing nut.
- Tightening the open/close bolt (see **Fig. 6.23**) on the clearance adjustment gauge will cause the gauge bore to expand.

With the gauge bore expanded by about 0.15 mm, insert the gauge into the outside

diameter portion of the roller set in the inner ring. Be careful not to damage the rollers (see **Photo 6.5**).

- Loosening the open/close bolt will cause the gauge bore to shrink.
 - Loosen the open/close bolt to bring the gauge bore into contact with the outside diameter of the roller set in the inner ring.
- Lightly swing the clearance adjustment gauge in the circumferential direction to stabilize the pointer on the dial gauge.

(4) Setup of inner ring clearance

- Tighten the precision bearing nut of the main spindle. This should be done gradually to prevent shock loading.
- Tightening the precision bearing nut further until the reading on the dial of the clearance adjustment gauge becomes zero in case the clearance is aimed at $0 \mu\text{m}$.
- Once the reading on gauge gets zero, carefully swing the adjustment gauge again to check that the measurement value is correct.
- Loosen the open/close bolt on the clearance adjustment gauge to expand the gauge bore and remove the gauge from the inner ring.

(5) Determination of spacer width

- The inner ring should now be in the position where the reading on the dial of clearance adjustment gauge was zero in step (4). By using a block gauge, measure the distance between the inner ring side face and shaft shoulder (dimension ℓ in **Fig. 6.24**).
- Measure this dimension in at least three locations, and finally adjust the spacer width ℓ to the average of three measurements.
- Loosen and remove the precision bearing nut, inner ring spacer and inner ring from the main spindle.

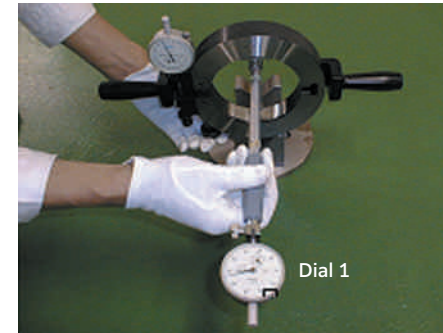

Photo 6.3

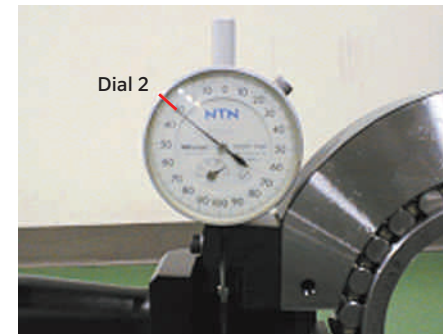

Photo 6.4



Photo 6.5

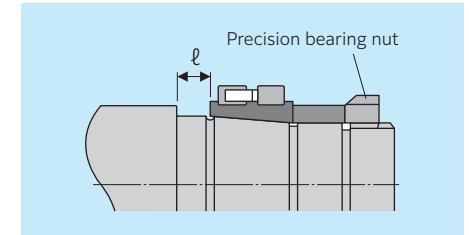

Fig. 6.24 Spacer width dimension

(6) Assembly and check of the mounted roller outside diameter

- Insert a spacer of width ℓ . Then insert the inner ring and mounting spacer and tighten the precision bearing nut.
- According to a procedure similar to that in steps (3) "Setting up the mounted internal clearance adjustment gauge on the main spindle" and (4) "Setup of inner ring clearance", check the mounted roller outside diameter and the clearance setting. Note this process is only a re-check procedure, and may be omitted once the clearance measurements fall in a smaller range.

● Replacement of mounted internal clearance by clearance correction factor

(1) Clearance correction factor

Because of the structure of the **NTN** mounted internal clearance adjustment gauge, the ratio of the clearance reading on location for measurement to the reading on dial gauge is 1:2.5 (clearance correction factor), (The clearance reading on the dial gauge is 2.5 times as large as the mounted internal clearance). For reference, a clearance reading conversion table is given in **Table 6.6**.

NOTE: Note that the clearance correction factor of certain bearing numbers is not 1:2.5. Clearance correction factor is given on the table of inspection results.

Table 6.6 Clearance reading conversion table (when clearance correction factor 2.5)

Reading on dial gauge (μm)	Mounted internal clearance on location for measurement (μm)	Reading on dial gauge (μm)	Mounted internal clearance on location for measurement (μm)
0.5	0.2	5.5	2.2
1.0	0.4	6.0	2.4
1.5	0.6	6.5	2.6
2.0	0.8	7.0	2.8
2.5	1.0	7.5	3.0
3.0	1.2	8.0	3.2
3.5	1.4	8.5	3.4
4.0	1.6	9.0	3.6
4.5	1.8	9.5	3.8
5.0	2.0	10.0	4.0

(2) Mounted internal clearance (when clearance indication value 1:2.5)

The reading on the dial gauge is converted into a mounted internal clearance in the following manner:

• CASE 1

The reading relative to the zero point is in the clockwise direction (CW) (see **Fig. 6.25**). The value of the mounted internal clearance (+) is 1/2.5 times as large as the reading on dial gauge.

Reading on dial gauge in **Fig. 6.25** = 2.5
 Mounted internal clearance = $2.5/2.5 = (+) 1 \mu\text{m}$

• CASE 2

The reading relative to the zero point is in the counterclockwise direction (CCW) (see **Fig. 6.26**). The value of the mounted internal clearance (-) is 1/2.5 times as large as the reading on dial gauge.

Reading on dial gauge in **Fig. 6.26** = 5.0
 Mounted internal clearance = $5.0/2.5 = (-) 2 \mu\text{m}$

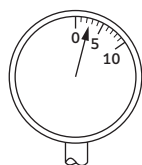

Fig.6.25
 Reading on dial gauge: +2.5 μm
 (mounted internal clearance: +1 μm)

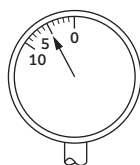

Fig.6.26
 Reading on dial gauge: -5 μm
 (mounted internal clearance: -2 μm)

● Example for setting mounted internal clearance

When setting the mounted internal clearance, adjust the dial gauge by shifting from the zero point to the "targeted clearance × clearance correction factor".

Examples for when clearance correction factor 2.5 are shown in **Fig. 6.27** and **Fig. 6.28**.

NOTE: Note the direction when adjusting the dial gauge by shifting from the zero point.

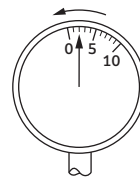

Fig. 6.27 Adjustment for negative clearance (mounted internal clearance: -0.8 μm)

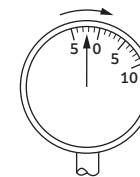

Fig. 6.28 Adjustment for positive clearance (mounted internal clearance: +1.0 μm)

<Precautions for using and storing the mounted internal clearance adjustment gauge>

When using the mounted internal clearance adjustment gauge, follow the precautions described below:

- When transferring the outer ring raceway diameter measured with the cylinder gauge to the mounted internal clearance adjustment gauge, use the adjustment gauge in a vertical attitude (see **Photo 6.6**).
- When not using the mounted internal clearance adjustment gauge, place it in a horizontal attitude (see **Photo 6.7**). Also, after completion of clearance measuring operation, apply rust-preventive oil to the mounted internal clearance adjustment gauge and store in a dry location.



Photo 6.6 Vertical storage attitude

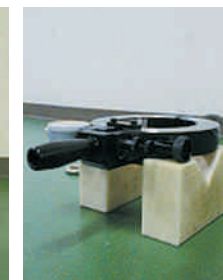

Photo 6.7 Horizontal storage attitude

6.8 Tapered bore cylindrical roller bearing and main spindle taper angle

In order for a precision bearing to perform as designed, it must be correctly mounted to a shaft and housing. In particular, when employing a tapered bore cylindrical roller bearing, accurate finish for the tapered main spindle and appropriate fit between the bearing bore and the main spindle are very important to ensure high accuracy of the main spindle. **NTN** recommends that the customer use the **NTN** tapered shaft ring gauge, which that is finished to same accuracies as the bearing, so that the customer can achieve higher precision. **NTN** also offers a plug gauge so that the customer can check the accuracy of the ring gauge.

■ Taper gauge for precision roller bearings

Each **NTN** precision cylindrical roller bearing taper gauge consists of a female gauge and a male gauge (plug gauge) (see **Fig. 6.29**).

Using blue paste or an equivalent as well as a ring gauge, check the fit of the bearing bore with the main spindle taper. The correct fit between the main spindle and the bearing leads to higher accuracy of the main spindle. The plug gauge is intended to check the accuracy of the associated ring gauge. Use the plug gauge to verify the taper accuracies of the associated ring gauge (see **Fig. 6.30**).

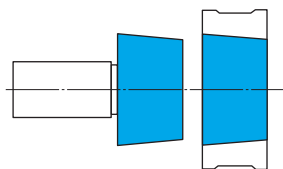

Fig. 6.30 Blue paste on taper gauge

■ Taper angle

NTN machines the tapered bore of its cylindrical roller bearings and the taper angle of its taper gauges according to the tolerances below:

- Nominal taper angle 1/12 (4° 46' 18.8")
- Tolerance for precision roller bearing with 1/12 taper angle is +12" ± 12" (JIS Class 4 and 2)
- Targeted tolerance for taper gauge 1/12 is +9".

Usually, Using blue paste between the tapered bore of a cylindrical roller bearing and a plug gauge exhibits a strong contact mark on the small diameter side as show in **Fig. 6.31**. This is because **NTN** has slightly adjusted the taper angle of the bearing bore to accommodate for the difference in thickness of the inner ring below each row of rollers.

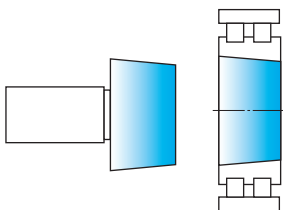

Fig. 6.31

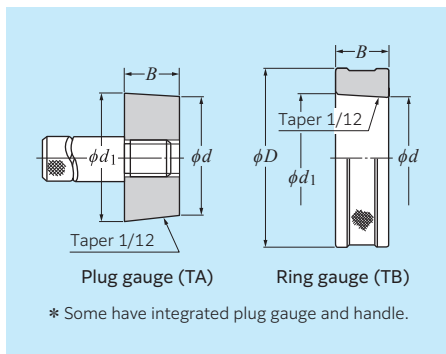

Fig. 6.29 Taper gauge

■ Checking main spindle taper with ring gauge

When checking the main spindle taper angle with a ring gauge, perform the following steps.

- Thoroughly clean the surface of the ring gauge, and apply a thin layer of blue paste to four equally-spaced points.
- Clean the tapered surface of the shaft, and gently insert into the ring gauge.
- The ring gauge to be lightly turning it.
- Check the patterns of blue paste deposited on the shaft surface.
- At this point, attach a strip of clear adhesive tape onto each blue paste spot, and peel off each strip.

Attach strips of adhesive tape onto white paper and check how much blue paste was deposited onto each point. Check that more than 80 % of the applied blue paste was deposited on the tapered surface.

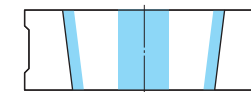

Fig. 6.32 Application of blue paste to ring gauge

Table 6.7 Examples of blue paste records

Region A	Small	Large
Region B	Small	Large
Region C	Small	Large
Region D	Small	Large

Small: small diameter side
Large: large diameter side

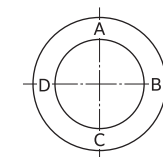

Fig. 6.33 Regions subjected to measurement with blue paste

6.9 Handling precautions

Bearings are precision parts and in order to preserve their accuracy and reliability, care must be exercised in their handling. In particular, bearing cleanliness must be maintained, sharp impacts avoided, and rust prevented.

Bearings are vulnerable to impact. Do not hit them with a hammer directly or drop them on the floor (see Fig. 6.34).

In addition, bearings are sensitive to foreign particle contamination. When foreign particles enter the bearing during rotation, denting and/or scratches may occur, resulting in objectionable noise and vibration levels and rough bearing rotation (see Fig. 6.35). Therefore, when handling bearings, it is necessary to keep the periphery clean.

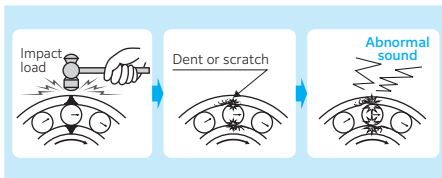

Fig. 6.34 Damage caused by impact

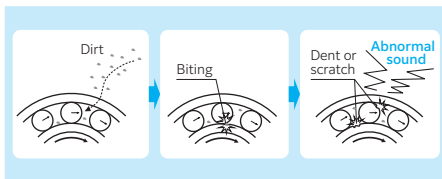

Fig. 6.35 Damage caused by foreign particle contamination

For optimal bearing performance, proper bearing handling methods must be used. The handling methods described herein are general guidelines. Depending on the type and size of bearing needed, special handling “methods” may be necessary. For more detailed information, please consult **NTN Engineering**.

Using proper protective equipment and tools

are also essential when installing or removing bearings, to avoid damage to the machinery and ensure the safety of the technician. Further information on proper installation and removal procedures is detailed in the following sections.

6.10 Bearing storage

Most rolling bearings are coated with a rust preventive oil before being packed and shipped. Please observe the following guidelines when storing bearings.

1. Ideally, bearings should be stored indoors at room temperature with a relative humidity of less than 60 %. Avoid places in direct sunlight or in contact with outer walls because excessive temperature fluctuation or humidity rise may cause condensation.
2. Bearings should not be stored directly on the ground. Instead, they should be placed on a shelf or pallet at least 20 cm above the ground. The maximum number of shipping boxes to be stacked for storage should be limited to four whenever possible (see Fig. 6.36).
3. Precision rolling bearings, large rolling bearings and thin ring or race rolling bearings must be laid down horizontally for storage (see Fig. 6.37). Storing them standing vertically may cause raceway deformation.

To avoid damage during transportation such as fretting or false brinelling, ensure that the individual bearing boxes are packed laying down horizontally within the shipping box. Fill remaining space with dunnage (see Fig. 6.38).

Some products have a ↑ symbol on the shipping box to prevent improper storage placement. Follow the indication on the box in this case (see Fig. 6.39).

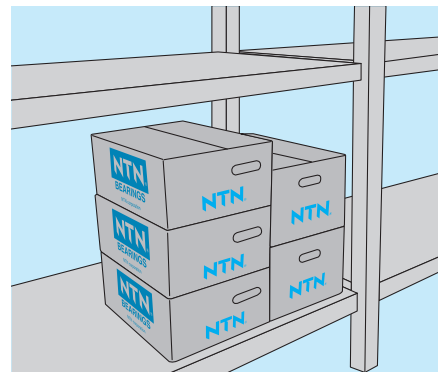

Fig. 6.36 Storing bearings on a shelf



Fig. 6.37 Storing one-bearing boxes on a shelf



Fig. 6.38 Transportation and storage by shipping box

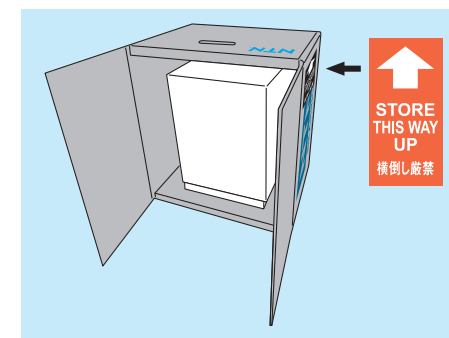

Fig. 6.39 Horizontally placing box prohibited

6.11 Bearing installation

A jig, a measuring instrument, a lubricant, and a clean and dry workshop will be needed for bearing installation. Further, if possible, it is desirable to install miniature/small ball bearings and precision rolling bearings in a clean room because intrusion of dirt and foreign matter significantly affects bearing performance.

Improper installation of bearings may cause marks from the rolling elements on the raceways, adversely affecting the bearing life. For details, on machining accuracy and mounting accuracy of bearings, shafts, and housings, for details please refer to the see technical data "2. Bearing selection and shaft & housing design."

■ Installation preparations

● Fitting surface of shafts and housings

When a bearing is installed on a shaft or in a housing with surfaces containing burrs or dents, the bearing may not seat properly, causing vibration and noise during operation (see Fig. 6.40 and Fig. 6.41).

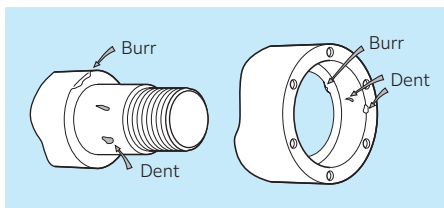

Fig. 6.40 Burrs and dents

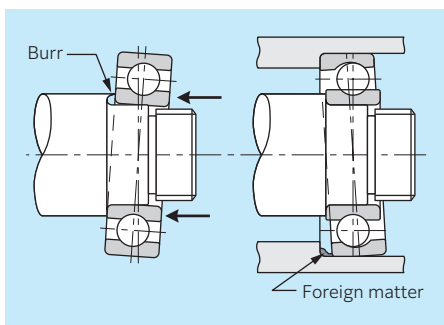

Fig. 6.41 Example of improper bearing installation

6.12 Running-in operation for main spindle bearings

Run-in is important for ensuring smooth operation of grease-lubricated main spindle bearings.

The following two modes of running-in are recommended:

- (1) The bearing speed is gradually increased in steps. After the temperature is saturated at each speed setting, the speed is increased to the next step (see Fig. 6.42).
- (2) The bearing is run for one minute at around the maximum operating speed of the spindle. This cycle is repeated two or three times (see Fig. 6.43) as needed.

(1) is the ordinary method used, however it takes slightly longer to reach the maximum operating speed of the spindle. In contrast, (2) can shorten the running-in time, however higher risk of sudden bearing temperature rise is considerable, so that running speed and its holding time must be set carefully.

Generally, the temperature of a main spindle bearing is measured on the front cover. The temperature difference across the bearing outer ring and front cover reaches 2 to 3 °C, and at the same time, the temperature difference between the hottest rolling element and the inner ring raceway surface seems to reach 50 to 10 °C. For this reason, **NTN** recommends that the machine is stopped if the temperature on front cover reaches approximately 60 °C. It is recommended that the temperature falls to 30 °C or less before restarting the running-in operation.

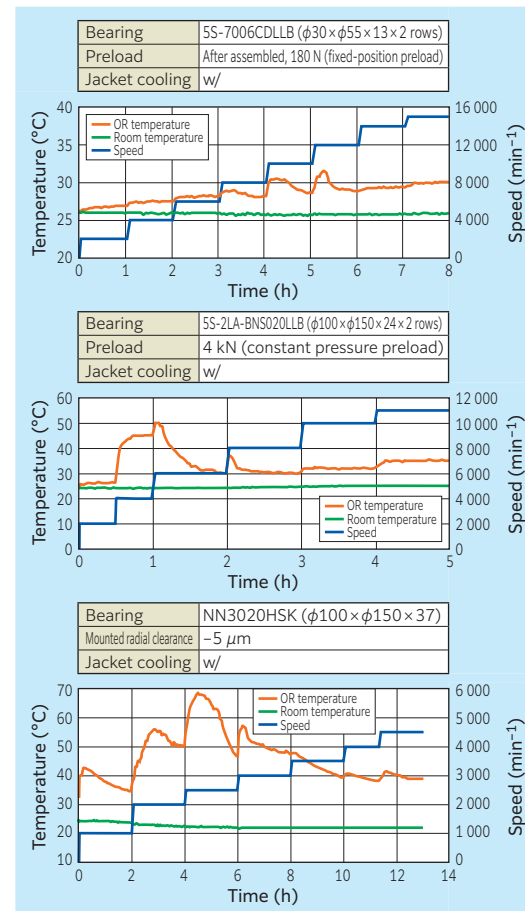

Fig. 6.42

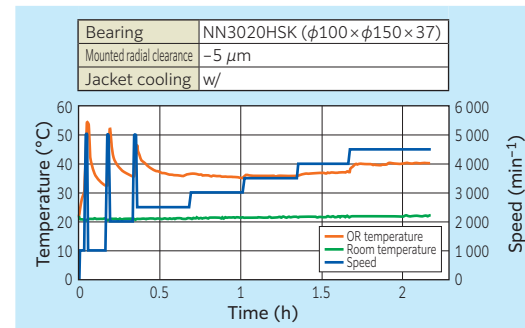

Fig. 6.43

7. Lubrication of Bearings

The purpose of rolling bearing lubrication is to prevent direct metallic contact between the various rolling and sliding elements. This is accomplished through the formation of a thin oil (or grease) film on the contact surfaces. Lubricant is necessary for operating rolling bearings. For rolling bearings, lubrication has the following advantages:

- (1) **Reduction of friction and wear**
It prevents direct metallic contact between the rolling and sliding elements of bearing components and reduces friction and wear.
- (2) **Prolonged bearing life**
The rolling fatigue life is prolonged by forming an oil film on the rolling contact surface part.
- (3) **Friction heat dissipation and cooling**
Circulating lubrication can dissipate heat generated from friction or conducted from the outside.
- (4) **Others**
It prevents foreign materials from entering inside the bearing and suppresses corrosion (rust) by covering the bearing surface with oil.

In order to exhibit these effects, a lubrication method that matches service conditions is required. In addition to this, a quality lubricant must be selected, the proper amount of lubricant must be used and the bearing must be designed to prevent foreign matter from getting in or lubricant from leaking out.

The main spindle of a machine tool usually uses an extremely low volume of lubricant so heat generation from stirring of the lubricant is minimal.

Fig. 7.1 summarizes the relationships between oil volume, friction loss, and bearing temperature.

The lubrication methods available for bearings in a machine tool include grease lubrication, oil mist lubrication, air-oil lubrication, and jet lubrication. Each method has unique advantages. Therefore, the lubricating system that best suits the lubrication requirements should be used.

Table 7.1 and **Table 7.2** summarize the features of various lubrication methods.

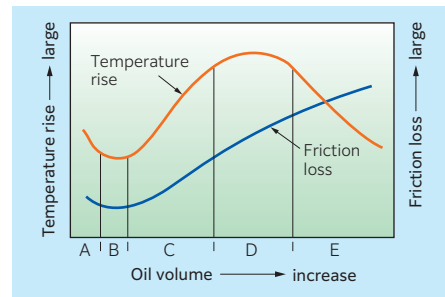

Fig. 7.1

Table 7.1 Oil volume, friction loss and bearing temperature (see Fig. 7.1)

Range	Characteristics	Lubrication method
A	When oil volume is extremely low, direct metallic contact occurs in places between the rolling elements and raceway surfaces. Bearing abrasion and seizing may occur.	—
B	A thin oil film develops over all surfaces, friction is minimal and bearing temperature is low.	Grease lubrication Oil mist lubrication Air-oil lubrication
C	As oil volume increases, heat buildup is balanced by cooling.	Circulating lubrication
D	Regardless of oil volume, temperature rises at a fixed rate.	Circulating lubrication
E	As oil volume increases, cooling dominates and bearing temperature decreases.	Forced circulating lubrication Jet lubrication

Table 7.2 Evaluation of various lubricating systems

Lubrication method	Grease lubrication	Oil mist lubrication	Air-oil lubrication	Jet lubrication
Criterion				
Handling	◎	○	○	△
Reliability	○	△	○	◎
Temperature rise	△	△	○	◎
Cooling effect	×	△	○	◎
Sealing structure	△	○	○	×
Power loss	○	○	○	×
Environmental contamination	○	×	△	○
Allowable $d_{mn}n$ value ¹⁾	1.4×10^6	2.2×10^6	2.5×10^6	4.0×10^6

Legend ◎ : Excellent ○ : Good △ : Fair × : Poor
 1) The permissible $d_{mn}n$ values are approximate values:
 d_{mn} : pitch circle diameter across rolling elements (mm)
 multiplied by speed (min^{-1})

7.1 Grease lubrication

Grease is popular amongst other lubricants because of its simpler maintenance. With an adequate amount of quality grease prefilled, this system can be used over a wide range of speed. The allowable maximum speed varies with the type and size of bearing: for a high speed angular contact ball bearing, the d_{m^n} value should be 1.4×10^6 as a guideline. For applications exceeding this range, consult **NTN Engineering**.

■ Grease types

When grease temperature rises during high speed operation, which can be seen for machine tool spindles, a grease with a consistency of NLGI2 or NLGI3 is recommended. For the base oil, ester oil and synthetic oil are used in addition to mineral oil. Urea, which has excellent high temperature properties, is used as a thickener in addition to lithium soap and barium complex soap.

Table 7.3 lists technical data for greases commonly used for machine tool main spindles.

■ Amount of grease required

Usually, a bearing for the main spindle of a machine tool requires that grease volume be low so heat generated by the stirring of the grease during high speed operation is minimal. A guideline for the amount of grease used for a main spindle bearing is given below.

- Angular contact ball bearing
 (d_{m^n} value $\leq 0.65 \times 10^6$);
 15 to 20 % of bearing free space
 (d_{m^n} value $> 0.65 \times 10^6$);
 12 to 17 % of bearing free space
- Cylindrical roller bearing;
 10 to 15 % of bearing free space
- Tapered roller bearing;
 15 to 20 % of bearing free space

The above is a guideline to determine the amount of grease required based on bearing free space listed in the bearing dimensions table. It is recommended to aim for the lower limit to reduce the running-in operation time.

Before filling a bearing with grease, remove the rustproof coating from the bearing with clean wash oil and allow the bearing to dry completely. Then fill and uniformly distribute an appropriate amount of grease in the bearing with a syringe, plastic bag, etc.

Table 7.3 Typical greases for machine tool main spindle bearings

Grease brand	SE-1	MP-1	ISOFLEX NBU 15	STABURAGS NBU 8 EP	Multemp LRL No.3	Multemp PS No.2
Thickener	Urea		Ba complex soap		Li soap	
Base oil	PAO + ester	Synthetic oil	Diester + mineral oil	Mineral oil	Synthetic oil	Ester + PAO
Base oil viscosity (40 °C) mm ² /s	22	40.6	23	105	37.3	15.9
Blend consistency NLGI No.	2	3	2	2	3	2
Dropping point °C	> 220	> 250	> 220	> 220	208	190
Operating temperature range °C	-50 to 120	-40 to 150	-40 to 130	-20 to 140	-40 to 150	-50 to 130
Application	Applied to ULTAGE Series grease-lubricated sealed angular contact ball bearings	Applied to ULTAGE Series grease-lubricated sealed angular contact ball bearings	Most commonly used for main spindles	Suitable for roller bearings subject to large loads	Wider operating temperature range	For low temperature and low torque
NTN grease code	L749	L448	15K	L135	12K	1K

Note: 1. Representative values are shown for the base oil viscosity, consistency, and dropping point.

2. The upper and lower limits of the operating temperature range differ depending on the usage environment and requirement specifications. Please consult with **NTN Engineering**.

7.2 Air-oil lubrication

Air-oil lubrication (also known as oil-air lubrication or oil and air lubrication) is widely adopted for main spindle bearings in order to cope with the higher speed and precision of machine tools and to ensure more reliable lubrication.

Air-oil lubrication employs a method by which compressed air is used to provide lubricating oil in precisely controlled amounts. Generally, an air-oil lubrication unit a volumetric piston-type distributor that accurately meters the required minimum amount of lubricating oil and provides it at optimal intervals controlled by a timer.

■ Features of air-oil lubrication

Air-oil lubrication has the following features over:

- Accurately supplies a minimal amount of oil.
- Can be adjusted to provide the proper amount of lubricant for individual bearings.
- It is easy to control the amount of oil depending on the viscosity of the lubricant.
- Compressed air helps cool the bearing.
- It reduces the amount of oil mist.
- Low oil consumption.
- Use of compressed air can prevent contamination of the bearing by other coolants.

■ Example of an air-oil lubrication system

Fig. 7.2 shows the configuration and example of an air-oil lubrication system.

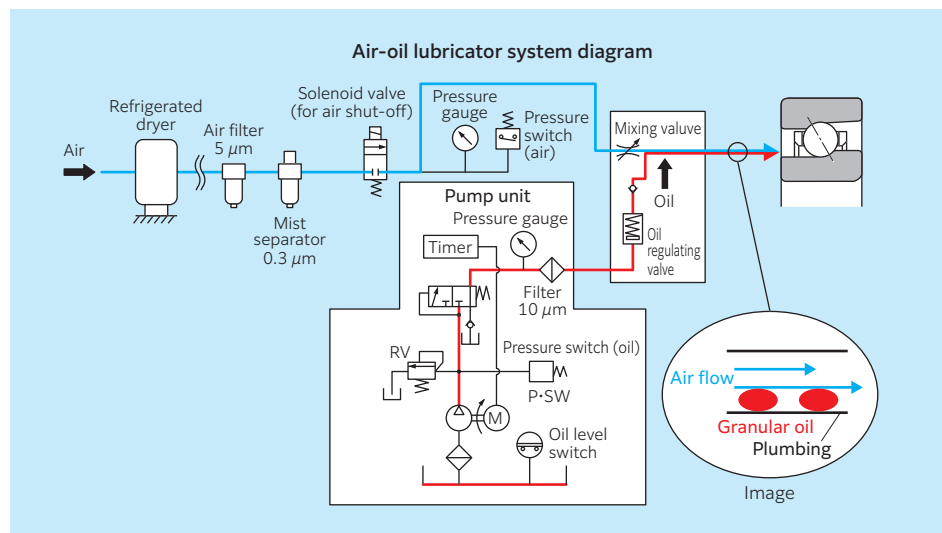

Fig. 7.2 Example of air-oil lubricating system

■ Air-oil lubrication nozzle spacer

Air-oil lubrication requires a specialized nozzle because it supplies the lubricating oil to the inside of the bearing by means of compressed air (see Fig. 7.3).

A nozzle with a hole diameter of 1.0 to 1.5 mm and a length 4 to 6 times the hole diameter is recommended.

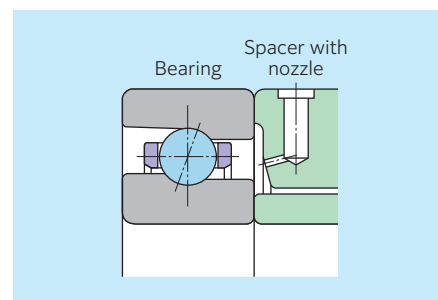

Fig. 7.3 Feed system for air-oil lubrication

■ Exhaust method for air-oil lubrication

Air-oil lubrication uses a large volume of air to feed lubricating oil to the bearing. Therefore, it is essential that the air fed into the bearing be allowed to escape. If the air is not smoothly exhausted, the lubricating oil will remain in the bearing and possibly contribute to bearing seizure. In the design stage, remember to allow ample space on the exhaust side of the bearing in order to increase exhaust efficiency and provide a larger oil drain hole to ensure smooth airflow. In addition, for types that allow for repositioning of the spindle, it is recommended that the shoulder dimensions of all parts is designed to prevent lubricating oil from flowing back into the bearing after a change in the attitude of the main spindle. Unnecessary dimensional differences can also contribute to stagnancy of the lubricating oil.

When lubricant is supplied between the cage and outer ring

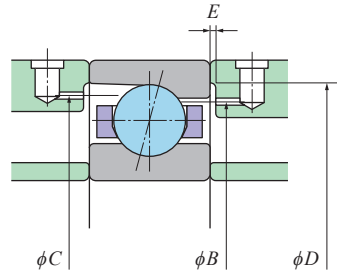

Fig. 7.6 78C and 79C types

Table 7.8 Air-oil/oil mist nozzle spacer dimensions

Unit: mm

Bearing No.	When lubricant is supplied between the cage and outer ring					
	<i>B</i>	<i>C</i>	Outside diameter of inner ring spacer	Bore diameter of outer ring spacer	<i>D</i>	<i>E</i>
7805C	32.6	33.3	28	29	34	1
7806C	37.6	38.2	33	34	39	1
7807C	42.6	43.1	38	39	44	1
7808C	47.8	48.4	43	44	49	1
7809C	53.2	54.3	48.5	49.5	54	1
7810C	59.5	60.2	54	55	60.5	1
7811C	66.2	67.4	59	61	68	1
7812C	71.7	72.8	64.5	66.5	73.5	1
7813C	77.7	78.7	70.5	72.5	79.5	1
7814C	82.4	83.6	75.5	77.5	84.5	1
7815C	87.8	88.8	80.5	82.5	89.5	1
7816C	92.5	93.6	85.5	87.5	94.5	1
7817C	101	102.5	91.5	93.5	103.5	1
7818C	106	107.3	96.5	98.5	108.5	1
7819C	111	112.4	101.5	104	113.5	1
7820C	115.6	117	106.5	110	118.5	1
7821C	120.7	122	111.5	115	123.5	1
7822C	129.2	131.1	117.5	122	132.5	1
7824C	139.2	141.1	127.5	132	142.5	1
7826CT1	152.3	154.5	139	144	156.5	1.5
7828CT1	162.3	164.5	149	155	166.5	1.5
7830CT1	175.3	177.8	160.5	167.5	180.5	1.5
7832CT1	185.5	188	170.5	177.5	190.5	1.5
7834CT1	198.7	201.5	181	188	204.5	1.5
7928CT1B	171.3	176.9	153	163	179	1.5
7930CT1B	187.2	193.8	165	179	197	1.5
7932CT1B	198.3	201.9	175	190	205	1.5
7934CT1B	208.2	211.9	185	200	215	1.5

Note) 7805C to 7834CT1, 7928CT1B to 7934CT1B ... *B* is recommended.
If targeting at *B* is impossible, targeting of *C* is acceptable.

(a) When lubricant is supplied between the cage and inner ring

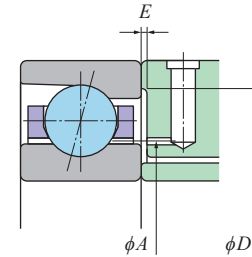

(b) When lubricant is supplied between the cage and outer ring

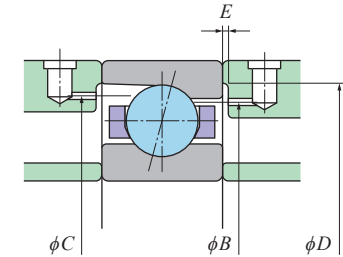

Fig. 7.7 70C and 72C types

Table 7.9 Air-oil/oil mist nozzle spacer dimensions

Unit: mm

Bearing No.	(a) When lubricant is supplied between the cage and inner ring			(b) When lubricant is supplied between the cage and outer ring				Common to (a) & (b)	
	<i>A</i>	Outside diameter of inner ring spacer	Bore diameter of outer ring spacer	<i>B</i>	<i>C</i>	Outside diameter of inner ring spacer	Bore diameter of outer ring spacer	<i>D</i>	<i>E</i>
7200C	—	—	—	23	23.8	15.5	17.5	25	1
7201C	—	—	—	24.9	25.8	17.5	19.5	27	1
7202C	—	—	—	28.3	29.4	20.5	22.5	30	1
7203C	—	—	—	32.4	33.7	23.5	26.5	35	1
7204C	—	—	—	38.4	40.2	26.5	31	41.5	1
7205C	—	—	—	43.3	44.7	32	36	46.5	1
7206C	—	—	—	51.1	53	37.5	44	54.5	1
7207C	—	—	—	59.1	61.2	43.5	52	64	1
7208C	—	—	—	65.9	68.3	49	58	71.5	1
7209C	—	—	—	71.3	73.8	54.5	63	76.5	1
7210C	—	—	—	76.4	78.8	59.5	68	81	1.5
7211C	—	—	—	84.6	87.4	66	76	90	1.5
7212C	—	—	—	94.4	97.5	72	85	99.5	1.5
7213C	—	—	—	100.8	104.1	77.5	92	108.5	1.5
7214C	—	—	—	106.2	109.6	83	96	114	1.5
7215C	—	—	—	112.2	115.6	88.5	102	118	1.5
7216C	—	—	—	119.5	123.2	94	109	127	1.5
7217C	—	—	—	128	131.8	100	117	136	1.5
7218C	—	—	—	136.2	140.4	106	125	146	1.5
7219C	119.4	111.5	113.5	144.4	149	111.5	132	155	1.5
7220C	126.1	117.5	120	152.7	157.7	117.5	141	164	1.5
7221C	131.6	122.5	125	159.9	165.1	122.5	148	173.5	1.5
7222C	138.3	129	131	168.5	174.1	129	157	182	1.5
7224C	149.3	141	143	181.5	187.2	141	169	196	1.5
7226C	161.3	152.5	155	193	199.2	152.5	181	210	1.5
7028CT1B	162.9	153	157	183.5	187.4	153	172	197	1.5
7030CT1B	174.4	165	169	196.6	200.9	165	185	210	1.5
7032CT1B	185.7	175	180	209.8	214.2	175	198	225	1.5
7034CT1B	199.2	185	193	226	231.3	185	214	245	1.5
7036CT1B	212.2	197	206	242	248	197	230	263	1.5
7038CT1B	222.2	210	216	252	258	210	240	270	1.5
7040CT1B	235.2	220	229	268	275	220	255	290	1.5

Note) 7200C to 7218C ... *B* is recommended.
7219C to 7226C, 7028CT1B to 7040CT1B ... *A* is recommended.
If targeting at *A* is impossible, targeting at *B* is acceptable. If both *A* and *B* are impossible, targeting of *C* is acceptable.

(2) Cylindrical roller bearings

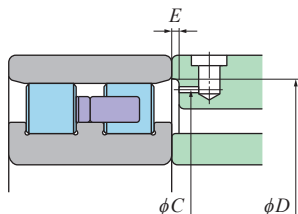

Fig. 7.8 NN30 and NN30T6 types

Table 7.10 Unit: mm

Bearing No.	C	Outside diameter of inner ring spacer	Bore diameter of outer ring spacer	D	E
NN3005	40.3	31	33.8	42	1
NN3006	47	38	40.5	50	1
NN3007	53.5	43	47.0	57	1
NN3008	59.5	48	53.0	63	1
NN3009	66	54	59.5	69	1
NN3010	71	59	64.5	74	1.5
NN3011	79	65	72.5	83	1.5
NN3012	84	70	77.5	88	1.5
NN3013	90 (89)	75	82.5	93	1.5
NN3014	98	82	90	102	1.5
NN3015	103	87	95	107	1.5
NN3016	111	93	103	115	1.5
NN3017	116	98	108	120	1.5
NN3018	125	105	117	130	1.5
NN3019	130	110	122	135	1.5
NN3020	135	115	127	140	1.5
NN3021	144 (143)	120	135	149	1.5
NN3022	153 (152)	127	144	158	1.5
NN3024	163 (162)	137	154	168	1.5
NN3026	179	150	171	185	1.5
NN3028	189	160	181	195	1.5
NN3030	202	172	194	210	1.5
NN3032	215.5	183	208	223	1.5
NN3034	232	196	224	240	1.5
NN3036	251	209	243	259	1.5
NN3038	261	219	253	269	1.5

NOTE) With certain products, the dimension C of L1 cage differs from that of T6 cage. The values in parentheses () are dimensions C of L1 cages. Other dimensions of L1 cages are same as those of T6 cages.

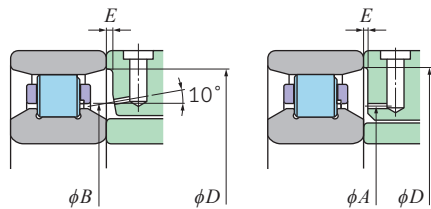

Fig. 7.9 N10HS types

Table 7.11 Unit: mm

Bearing No.	A	B	Outside diameter of inner ring spacer	Bore diameter of outer ring spacer	D	E
N1006HS	—	40.4	37	38	50	1
N1007HS	—	46.5	42	43	57	1
N1008HS	—	51.7	47	48	63	1
N1009HS	—	57.7	52	53	69	1
N1010HS	—	62.7	57	58	74	1.5
N1011HS	—	69.7	63.5	64.5	83	1.5
N1012HS	—	74.8	68.5	69.5	88	1.5
N1013HS	—	79.7	73.5	74.5	93	1.5
N1014HS	86	—	78.5	80.5	102	1.5
N1015HS	91	—	83.5	85.5	107	1.5
N1016HS	97.5	—	88.5	90.5	115	1.5
N1017HS	102.5	—	93.5	95.5	120	1.5
N1018HS	110	—	102	104	130	1.5
N1019HS	115	—	107	109	135	1.5
N1020HS	120	—	112	114	140	1.5
N1021HS	125.9	—	118	120	149	1.5
N1022HS	133.1	—	123	125	158	1.5
N1024HS	143.3	—	133	135	168	1.5
N1026HS	157.2	—	143	145	185	1.5
N1028HS	167.2	—	153	155	195	1.5
N1030HS	179.6	—	165	167	210	1.5
N1032HS	191.1	—	175	177	223	1.5

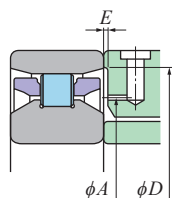

Fig. 7.10 N10HSR types

Table 7.12 Unit: mm

Bearing No.	A	Outside diameter of inner ring spacer	Bore diameter of outer ring spacer	D	E
N1009 HSRT6	58.3	52	53	69	1.0
N1011 HSRT6	71.5	63.5	64.5	83	1.5
N1012 HSRT6	76.6	68.5	69.5	88	1.5
N1013 HSRT6	81.5	73.5	74.5	93	1.5
N1014 HSRT6	89.7	78.5	80.5	102	1.5
N1016 HSRT6	101.3	88.5	90.5	115	1.5
N1018 HSRT6	113.8	102	104	130	1.5
N1020 HSRT6	123.8	112	114	140	1.5

7.3 Jet lubrication

With this lubricating system, a high speed jet of lubricant is injected into the bearing from the side. This is the most reliable lubricating technique and is typically used on the main spindle bearings of jet engines and gas turbines. It is currently capable of a $d_m n$ value of up to approximately 4.0×10^6 .

When used as a lubricating system for the main spindle of a machine tool, it can minimize the temperature rise of the bearing.

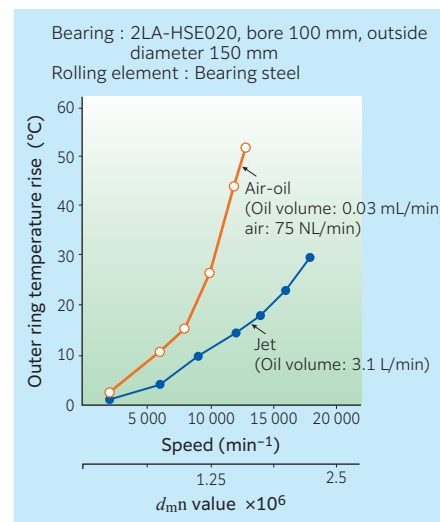

Fig. 7.11 Comparison of temperature rise of outer ring with air-oil lubrication and jet lubrication

(The temperature rise with air-oil lubrication is relative to room temperature; the temperature with jet lubrication is relative to lubricant temperature.)

However, the resultant torque loss is great, as a large amount of oil is supplied to each bearing. Therefore, this arrangement requires a powerful motor to drive the main spindle. Low viscosity oil (2 to $3 \text{ mm}^2/\text{s}$) is used.

Fig. 7.11 shows examples of the temperature rise with air-oil lubrication and jet lubrication, while Fig. 7.12 graphically plots test results of power loss.

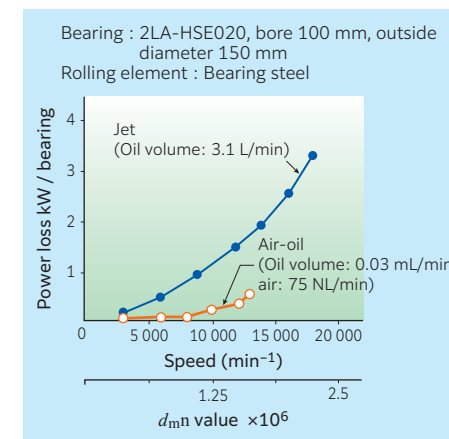

Fig. 7.12 Comparison of power loss with air-oil lubrication and with jet lubrication

8. Precision Bearing Technologies

8.1 ULTAGE™ series precision bearings for machine tool main spindles

NTN has responded to need for improved efficiency, reliability, quality and environmental responsibility for machine tools by developing the ULTAGE series of precision bearings. ULTAGE series of bearings demonstrates excellent performance thanks to the optimal internal design; a new approach to surface quality; and the use of special materials, special grease, and seals on both sides.

ULTAGE is the name for NTN's goal of achieving the ultimate performance with precision bearings, and expresses the "ULTIMATE" performance on any type of "STAGE."

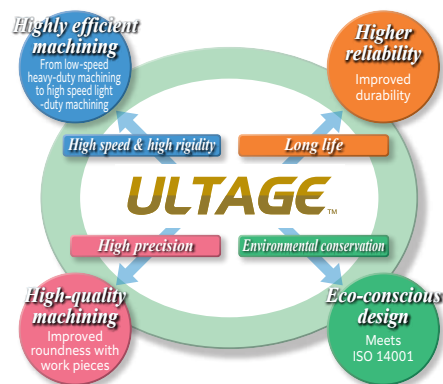

■ Concept

Our ideal is to offer a ultra high speed precision bearing that offers excellent reliability while remaining eco-friendly.

[Design]

The internal bearing design has been optimized to cope with varying applications and operating conditions in order to realize high speed and high rigidity, limited temperature rise, high precision, energy saving and low noise emission. It performs optimally in a variety of situations.

[Material]

Adoption of special material and a special surface modification technique has resulted in greatly enhanced reliability.

[Lubrication]

Use of unique eco-conscious technology and special grease contributes to decreased pollution and enhanced energy savings.

[Precision]

Our ultra high precision technology, in conjunction with our proven precision bearing technology, will help attain further improved precision.

8.2 Material and surface modification

The ULTAGE series high speed and ultra high speed precision bearings for machine tool main spindle employs a special material that boasts excellent anti-seizure properties and wear resistance, as well as a unique surface modification technique.

■ Life under normal temperatures

The test results obtained from point contact test pieces under greater loading are graphically plotted in Fig. 8.1.

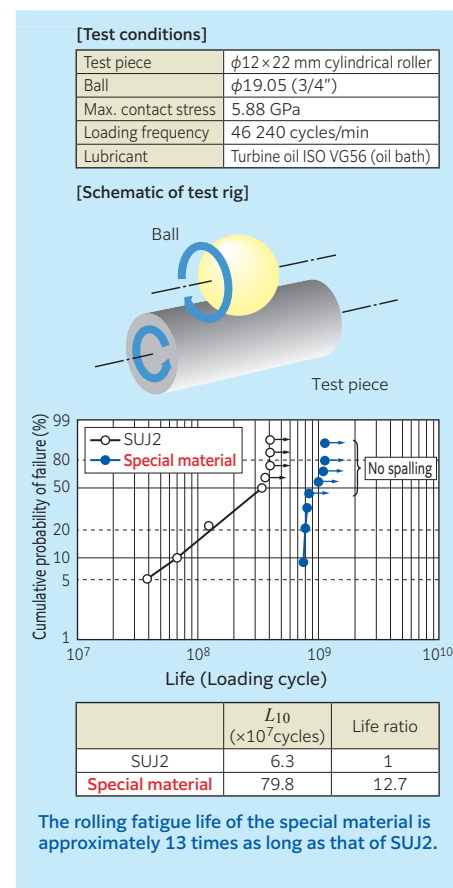

Fig. 8.1 Life test results with point contact test pieces

■ Life under high temperature

The test results obtained from thrust-type test pieces at 200 °C are graphically plotted in Fig. 8.2.

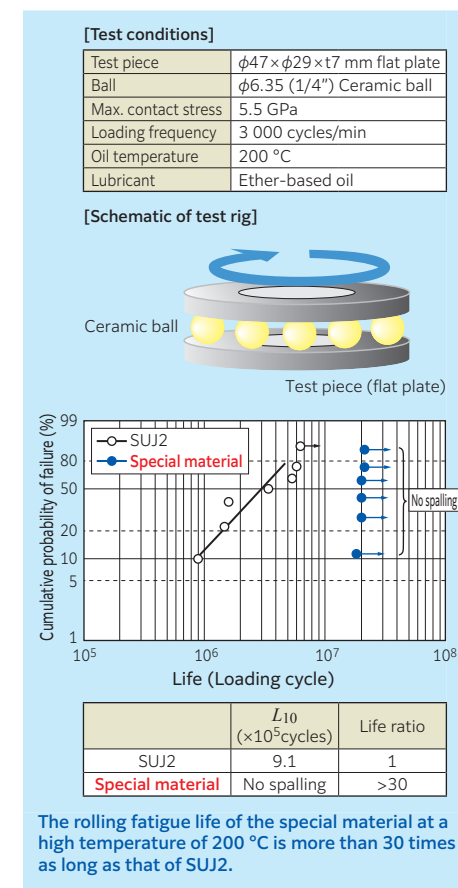

Fig. 8.2 High temperature life test results with thrust-type test pieces

■ Improved wear resistance

Test results with a Sawin type friction and wear test machine are illustrated in Fig. 8.3.

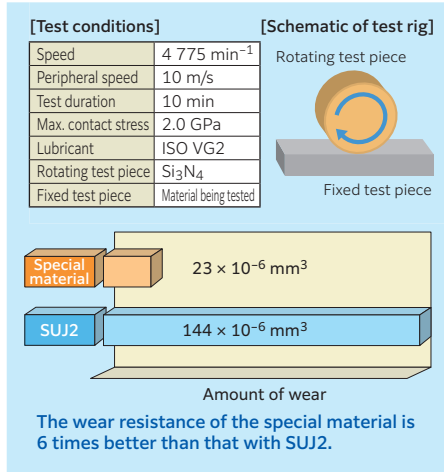

Fig. 8.3 Test results with Sawin type friction and wear test machine

■ Improved anti-seizure property

Test results with a two roller testing machine are illustrated in Fig. 8.4.

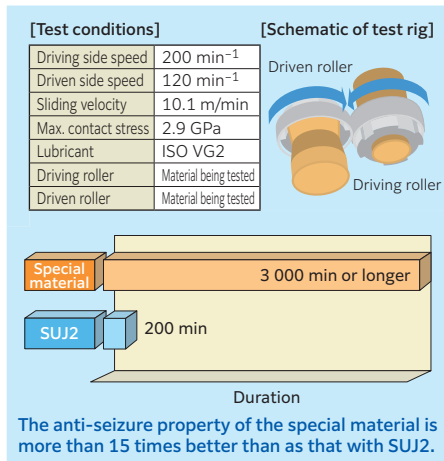

Fig. 8.4 Test results with a two roller testing machine

■ Adoption of ceramic balls

A comparison of temperature rise, which can vary depending on the material of rolling element, is illustrated in Fig. 8.5.

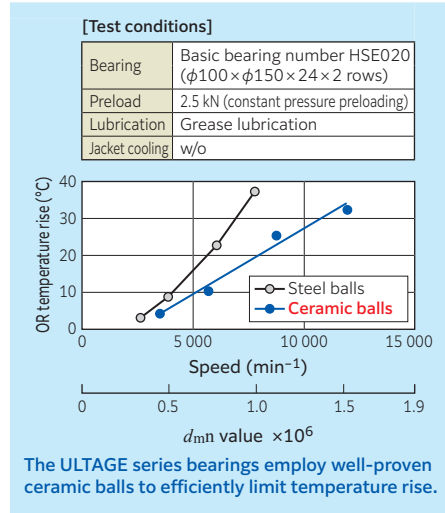

Fig. 8.5 Comparison of temperature rise with steel and ceramic rolling elements

8.3 Environmentally conscious technology

The eco-friendly ULTAGE series is available in two specifications: an eco-friendly air-oil lubrication design that offers energy savings by reducing air and oil consumptions; and a grease-lubricated, sealed design that reduces environmental impact by employing a grease lubrication system that is capable of higher-speed operation.

Required functions for the main spindle bearing

Speed Rigidity Durability Precision Eco-friendly design

For main spindles

Eco-friendly air-oil lubrication

HSL type N10HSLT6 type

Reduced air/oil consumption contributes to energy savings.

Grease lubrication

Standard 79 LLB/70 LLB types High speed BNS LLB type N10HSRT6 type

Sealed Sealed

The introduction of a grease lubrication system that is capable of high speed operation reduces the environmental impact.

For ball screw support

Grease lubrication

2A-BST LXL type 2A-BST type

Sealed

Combines durability with ease of handling. Durability

Grease-lubricated sealed angular contact ball bearings

(1) Ease of handling

ULTAGE series sealed angular contact ball bearings are grease-prefilled bearings. No grease filling is necessary; you need only wipe off the rust-preventive oil before assembly. Seals of different colors are employed to differentiate the front and back. The black front face and orange back face are easily identified, which also makes it easy to orient the bearings in combinations (see **Table 8.1**).

Table 8.1 Bearing combinations and seal colors

DB set (back-to-back)	DF set (face-to-face)

(2) Suggestions for simplified spindle structure

The ULTAGE series sealed angular contact ball bearing makes possible high speed operation with grease lubrication thanks to optimized internal design. Grease lubrication with minimal mist splash simplifies main spindle structure and contributes to lower environmental impact as well as cost reduction (see **Fig. 8.6**).

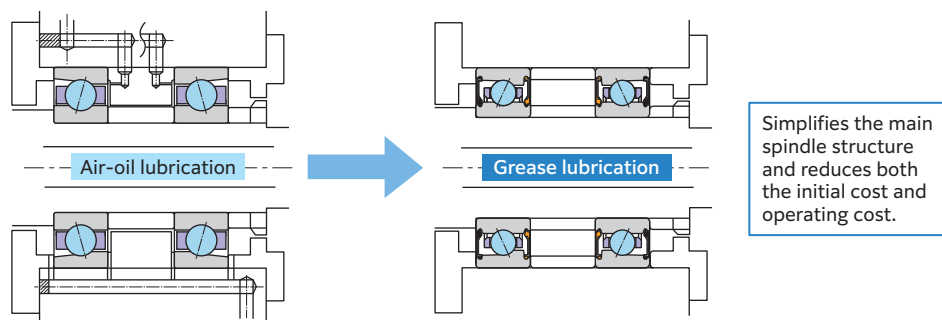

Fig. 8.6 Alteration to lubrication system (air-oil lubrication to grease lubrication)

Eco-friendly air-oil lubricated angular contact ball bearings and cylindrical roller bearings

When combined with the eco-friendly nozzle, the eco-friendly air-oil lubricated angular contact ball bearing (HSL/HSFL types) or cylindrical roller bearing [N10HSL (K) type] can reduce the emissions of oil mist and noise.

(1) Reduction of oil mist





The eco-friendly air-oil lubricated bearing does not spray compressed air from the nozzle; instead, it uses the centrifugal force of the rotating inner ring to supply lubricating oil into the bearing. For this reason, this type of bearing conserves both air and oil. In addition, it reduces the amount of oil mist emitted from the labyrinth seal of the spindle. The **Table 8.2** reveal the difference between the amount of oil mist emitted from the standard bearing and that emitted from the eco-friendly bearing.

The lubricating oil discharged with air passes through the inside of the bearing and is then exhausted as a large volume of mist.

The lubricating oil exhausted from the bearing in the mist state is collected through the discharge port of the main spindle housing, but some of the oil mist leaks from the main spindle labyrinth seal and contaminates the immediate environment around the machine.

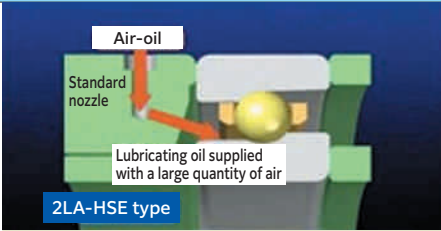
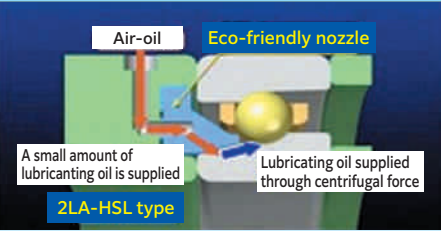
Adoption of the eco-friendly bearing therefore improves the working environment.

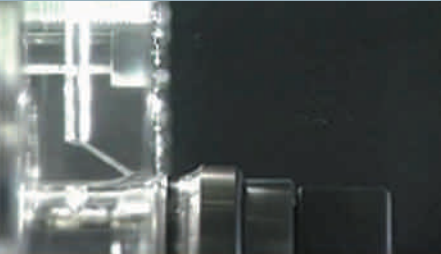
Table 8.2 Comparison of oil mist emissions between standard bearing and eco-friendly bearing

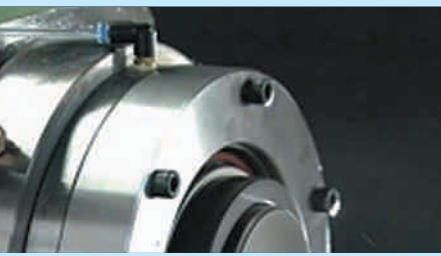
Standard bearing	Eco-friendly bearing
 <p data-bbox="103 499 544 547">Standard bearings consume a great deal of air when supplying lubricating oil to the bearing.</p>	 <p data-bbox="575 499 1016 547">The eco-friendly type uses centrifugal force to supply lubricating oil into the bearing.</p>
 <p data-bbox="103 818 544 850">The oil emitted from the nozzle is in a mist state.</p>	 <p data-bbox="575 818 1016 850">The oil emitted from the nozzle is in a liquid state.</p>
 <p data-bbox="103 1114 544 1161">A large amount of oil mist, contaminating the working environment.</p>	 <p data-bbox="575 1114 1016 1161">It reduces the amount of oil mist discharged and improves the working environment.</p>

(2) Noise Reduction

The standard air-oil lubrication method uses air to supply a slight amount of oil. It also uses a special nozzle spacer, as shown in Fig. 8.7 and Fig. 8.9.

In addition, this method uses a nozzle measuring 1 to 1.5 mm in diameter to supply oil to the raceway surface of the bearing at the rate of 30 to 40 NL/min/bearing. To supply this oil, the nozzle emits compressed air as a jet to break the air barrier of the bearing, which is created when running at high speed. In this way, the air is used as a tool for supplying oil. The eco-friendly bearing developed by NTN reduces the amount of air consumed, thus reducing the whistling noise of the flowing air. The mechanism used in this type of bearing is as follows: the centrifugal force of the bearing inner ring feeds a small amount of oil from the nozzle to the raceway surface of the bearing along the tapered surface (see Fig. 8.8 and Fig. 8.10).

Since the function of the compressed air is only to deliver lubricating oil to the cavity of the inner ring, a large quantity of air is not required. In addition, since the air used to supply the oil is released between the tapered surfaces, the whistling noise of air is also reduced.

When the eco-friendly bearing is employed, the noise is reduced by 6 to 8 dBA.

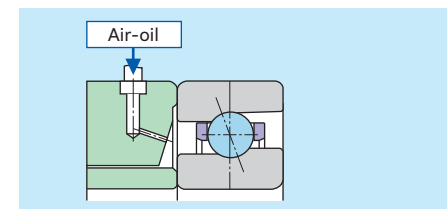

Fig. 8.7 Standard nozzle

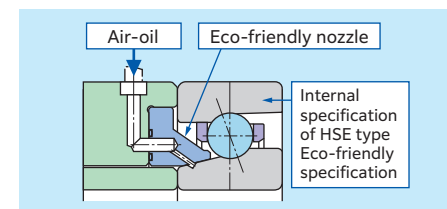

Fig. 8.8 Eco-friendly type nozzle

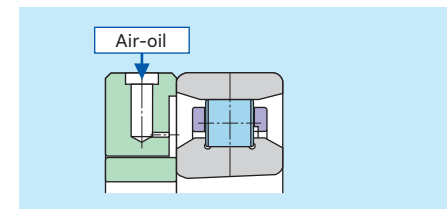

Fig. 8.9 N10HS type

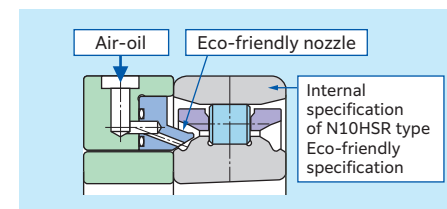

Fig. 8.10 N10HSL type

Example:

In the high speed region in excess of 10 000 min⁻¹, noise is reduced by 6 to 8 dBA (see Fig. 8.11).

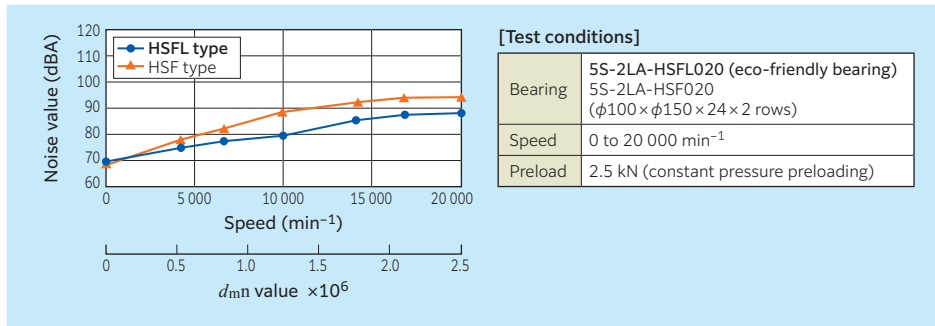

Fig. 8.11 Comparison of noise values

The eco-friendly bearing is particularly good for reducing “screeching” noise. The high-frequency component of the noise generated at high speeds is well attenuated. The reason for this is as follows: when the air jet emitted from the standard nozzle hits the rolling elements, a high-pitched noise is generated; in contrast, the eco-friendly nozzle does not emit air on the rolling elements, which reduces screeching noise (see Fig. 8.12 and Fig. 8.13).

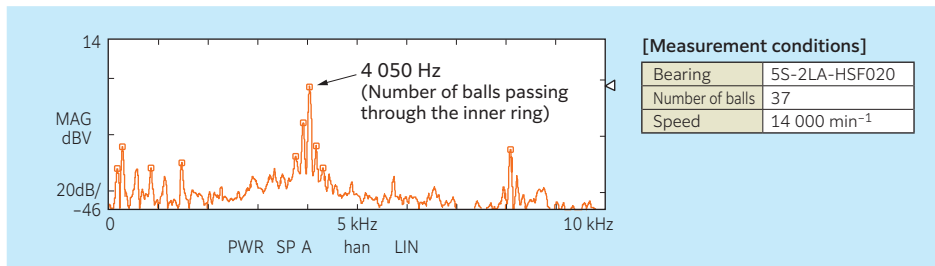

Fig. 8.12 Bearing noise frequency analysis results (Standard nozzle)

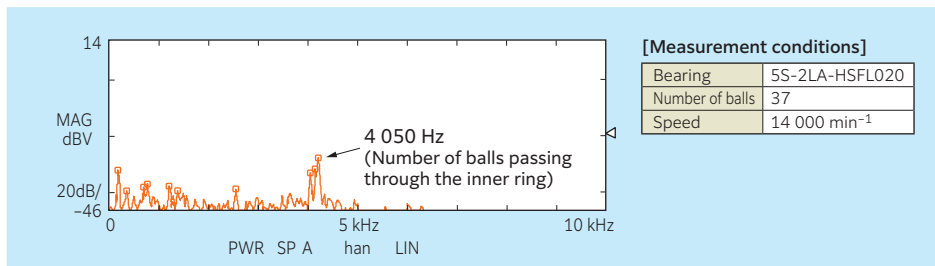

Fig. 8.13 Bearing noise frequency analysis results (Eco-friendly nozzle)



Main Spindle Bearings

9. Angular Contact Ball Bearings for Radial Loads CONTENTS

9.1	Types and features	86
9.2	Standard cage types	89
9.3	Bearing designations	90
9.4	Bearing accuracy	92
9.5	Internal clearance and standard preload of duplex angular contact ball bearings	94
9.6	Recommended fits for angular contact ball bearings	102
9.7	Duplex angular contact ball bearings	103
9.8	Duplex arrangement codes of duplex angular contact ball bearings	104
9.9	Flush ground and universal matching	104
9.10	Angular contact ball bearings with ceramic balls	106
9.11	Operating life of bearings with ceramic balls	107
9.12	Recommended lubrication specifications	108
9.13	Standard angular contact ball bearings 79U and 70U types	109
9.14	High speed angular contact ball bearings HSE type	110
9.15	Ultra high speed angular contact ball bearings HSF type	112
9.16	Eco-friendly air-oil lubricated angular contact ball bearings HSL type, HSFL type	113
9.17	Air-oil lubricated high speed angular contact ball bearings with re-lubricating hole on the outer ring, HSEW type	116
9.18	Grease-lubricated sealed standard angular contact ball bearings 79LLB/70LLB types	119
9.19	Grease-lubricated sealed high speed angular contact ball bearings BNS LLB type	122
Dimension Tables		
	Standard angular contact ball bearings	126
	High speed angular contact ball bearings	154
	Ultra high speed angular contact ball bearings	178
	Eco-friendly high speed angular contact ball bearings	180
	Eco-friendly ultra high speed angular contact ball bearings	188
	Air-oil lubricated high speed angular contact ball bearings with re-lubricating hole on the outer ring, HSEW type	190
	Grease-lubricated sealed standard angular contact ball bearings	198
	Grease-lubricated sealed high speed angular contact ball bearings	214
	Angular contact ball bearings for grinding machines / motors	238

9. Angular Contact Ball Bearings for Radial Loads

Angular contact ball bearings for radial loads used in machine tools are bearings which inner and outer rings cannot be separated. This series of bearing includes 78, 79U, 70U, 72, HSE9, HSE0, BNS9, BNS0, BNT9, BNT0 and BNT2 types. For angular contact ball bearings, an imaginary straight line connecting the contact points between the balls and inner and outer rings forms an angle with the radial axis. The optimal contact angle can be selected to meet functional requirements such as high speed or high rigidity. The available contact angles are 15° (contact angle symbol "C"), 20° (no symbol), 25° ("AD"), and 30° (no symbol) (see Fig. 9.1).

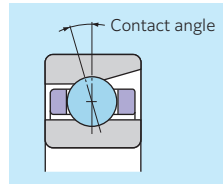

Fig. 9.1 Contact angle

9.1 Types and features

Open bearings

■ Standard angular contact ball bearings (78, 79, 70 and 72 Types)

Standard angular contact ball bearings are available in four types: 78, 79, 70 and 72. Types 79 and 70 include the 79U and 70U ULTAGE series, which accommodate high speed and low temperature rise with optimized specifications of the internal design. For these types, three contact angles are available: 15° (contact angle symbol "C"), 25° ("AD"), and 30° (no symbol). The contact angle of 25°, however, is also available with 79U and 70U types. This bearing series has an accuracy of JIS Class 5 or better. The features include high speed, high rigidity, and high load capacity. Some models incorporate ceramic balls.

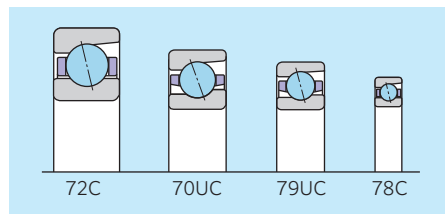

Fig. 9.2 Standard angular contact ball bearings

■ High speed angular contact ball bearings (HSE type)

High speed angular contact bearings are available in two types: HSE9 and HSE0. The boundary dimensions of this bearing series are determined according to the JIS dimension series (9, 0), and three types of contact angles are available: 15° (contact angle symbol "C"), 20° (no symbol), and 25° ("D"). The accuracy of this ball bearing series is JIS Class 5 or better, and the ball diameter is smaller than that of the standard angular contact ball bearing in order to accommodate high speeds. The outer surface of the inner ring and the bore of the outer ring are relieved on one side, and this bearing series employs an air-oil lubrication system to ensure smooth oil flow. In addition, it employs special materials, and its surface is modified to protect the bearing from wear and seizure more positively. The HSE type bearing is available with either steel balls or ceramic balls.

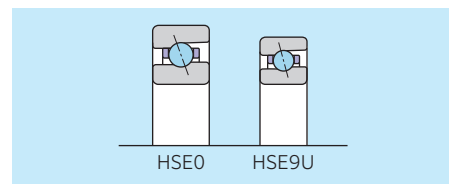

Fig. 9.3 High speed angular contact ball bearings

■ Ultra high speed angular contact ball bearings with ceramic balls (HSF type)

The HSF0 type ultra high speed angular contact ceramic ball bearing employs smaller balls than the HSE0C type to ensure rigidity and prevent temperature rise. In addition, it employs a contact angle of 25° to accommodate the reduction in contact angle caused by centrifugal force during operation.

These characteristics with air-oil lubrication support bearings with a d_{mn} value $\leq 2.6 \times 10^6$.

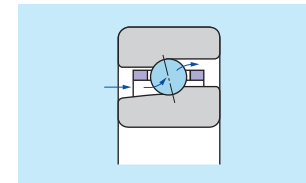

Fig. 9.4 Ultra high speed angular contact ball bearings

■ Eco-friendly air-oil lubricated angular contact ball bearings (HSL and HSFL types)

For eco-friendly air-oil lubricated angular contact ball bearings (HSL and HSFL types), the angle of the inner ring outer surface (counterbore area) is optimized compared with that of HSE and HSF types. In addition, these angular contact ball bearings are dedicated to air-oil lubrication by adopting a circumferential groove and an eco-friendly nozzle. They accommodate the same high speed as HSE and HSF types while being more eco-friendly. They generate less noise and conserve energy since they consume less air and oil. The accuracies of these bearing types are JIS Class 5 or better. For the HSL type, two contact angles 20° (no symbol), and 25° ("AD") are available. For the HSFL type, contact angle 25° ("AD") is available. The HSFL type utilizes a specially designed eco-friendly nozzle.

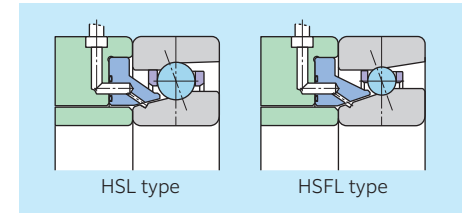

Fig. 9.5 Eco-friendly angular contact ball bearings

■ Air-oil lubricated high speed angular contact ball bearings with re-lubricating hole on the outer ring (HSEW type)

HSEW type is designed based on HSE type as high speed angular contact ball bearing for air-oil lubrication with lubrication hole on outer ring.

Spacers next to these bearings don't need length for nozzle to be mounted, and can be short. These short spacers have an effect on compact design and rigidity of spindle as a result of shortened distance between bearing and tool.

In addition, direct air-oil supply through the hole on outer ring achieves improved lubricating reliability with low air flow rate and small oil consumption.

JIS Class 5 or higher bearing accuracy is applied on this type. Two kind of contact angles are available, 20° (no symbol) and 25° ("AD").

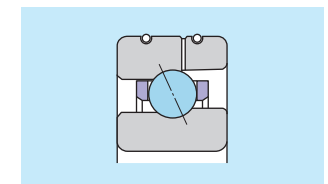

Fig. 9.6 Air-oil lubricated high speed angular contact ball bearings with re-lubricating hole on the outer ring

■ High speed angular contact ball bearings for grinding machines/motors (BNT type)

The boundary dimensions of high speed angular contact ball bearings for grinding machines/motors (BNT type) are determined according to the JIS dimension series (9, 0, 2). For this bearing type, only one contact angle (15°, no symbol) is available, and the bearing accuracies are JIS Class 5 or better. This bearing uses mainly air-oil lubrication and oil mist lubrication. The features of this bearing are high speed capability and high load capacity. This type of bearing is available with either steel balls or ceramic balls.

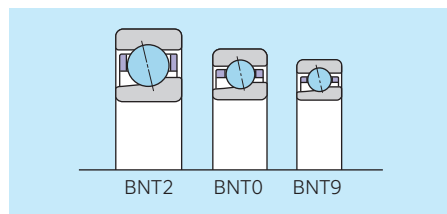

Fig. 9.7 High speed angular contact ball bearings for grinding machines/motors

Sealed bearings

■ Grease-lubricated sealed standard angular contact ball bearings (79LLB/70LLB types)

The grease-lubricated sealed standard angular contact ball bearings are available in 79 and 70 series. Non-contact rubber seals are mounted on both sides and special grease is used. As a result, these bearings accommodate high speed, offer prolonged service life, and help to maintain a comfortable working environment. These bearings are available in contact angles of 15° (contact angle symbol “CD”) and 25° (“AD”) and with a special accuracy of P42 (JIS Class 4 dimensional accuracy and JIS Class 2 running accuracy). Since they are prefilled with grease, these bearings require no cleaning before use and are therefore easy to handle. They are available with either steel balls or ceramic balls.

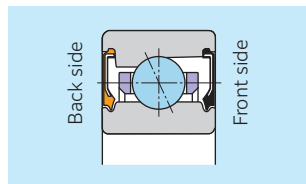

Fig. 9.8 Grease-lubricated sealed standard angular contact ball bearings

■ Grease-lubricated sealed high speed angular contact ball bearings (BNS LLB type)

Grease-lubricated sealed high speed angular contact ball bearings (BNS LLB type) are available with the boundary dimensions of HSE type. Non-contact rubber seals are incorporated on both sides and its inner structure is optimized. It is also prefilled with a special grease to achieve high speed capability, inhibit temperature rise, extend service life and create a comfortable working environment. This bearing type is available in contact angles of 15° (contact angle symbol “CD”), 20° (no symbol), and 25° (“AD”). Bearing accuracy is JIS Class 4 or better. The bearing ring is made of a special material, and the surface is modified to protect the bearing from wear and seizure. Since this type is prefilled with grease, it requires no cleaning before use and is therefore easy to handle. It is available with either steel balls or ceramic balls.

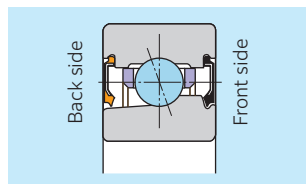

Fig. 9.9 Grease-lubricated sealed high speed angular contact ball bearings

9.2 Standard cage types

Table 9.1 Standard cage of angular contact ball bearings for radial loads

Bearing type	Polyamide resin cage	Machined phenol resin cage	Machined high tensile brass cage
78C	—	7805C to 7824C	7826C to 7834C
79U (15°, 25°, 30°), 79C	7900U to 7926U	—	7928C to 7934C
70U (15°, 25°, 30°), 70C	7000U to 7028U	—	7030C to 7040C
72C	7200C to 7220C	7221C to 7228C	—
HSE9U (15°, 20°, 25°)	—	HSE910U to HSE934U	—
HSE0 (15°, 20°, 25°)	—	HSE010 to HSE034	—
HSF0	—	HSF010 to HSF020	—
HSL9U (20°, 25°)	—	HSL910U to HSL926U	—
HSL0 (20°, 25°)	—	HSL010 to HSL026	—
HSFL0	—	HSFL010 to HSFL020	—
HSEW9U (20°, 25°)	—	HSEW910U to HSEW920U	—
HSEW0 (20°, 25°)	—	HSEW010 to HSEW020	—
79 LLB (15°, 25°)	7900 LLB to 7910 LLB	—	—
70 LLB (15°, 25°)	7000 LLB to 7010 LLB	—	—
BNS9 LLB (15°, 20°, 25°)	—	BNS910 LLB to BNS920 LLB	—
BNS0 LLB (15°, 20°, 25°)	—	BNS010 LLB to BNS020 LLB	—
BNT9	—	BNT900 to BNT913	—
BNT0	—	BNT000 to BNT014	—
BNT2	—	BNT200 to BNT216	—

Note 1) Cage design is subject to change without notice. For detailed information, contact NTN Engineering.

2) The polyamide resin cage can be used up to the following rotating speeds depending on the material of the rolling element. The d_{min} value 0.9×10^6 for bearing steel and d_{min} value 1.0×10^6 for ceramics. Machined phenol resin cages must be used if the allowable speed listed in the dimension tables exceeds the figures above. For detailed information, contact NTN Engineering.

9.3 Bearing designations

78, 79, 70 and 72 types

5S- 7 0 20 U C T1 DB /GL P4

- Precision class**
P5: JIS Class 5, P4: JIS Class 4, P2: JIS Class 2
- Internal clearance code**
GL: Light preload, GN: Normal preload, GM: Medium preload, Gxx: Special preload, CSxx: Special clearance
- Matching code**
DB: Back-to-back (double-row)
DT: Tandem (double-row)
DTBT: Tandem back-to-back (quad-row)
G: Flush ground (single-row)
- Cage code**
T1: Machined phenol resin cage
L1: Machined high tensile brass cage
No code: Standard cage
- Contact angle code**
C: 15°, AD: 25°, No symbol: 30°
- Bearing series (ULTAGE series)**
- Bore diameter code (See dimension table)**
- Dimension series code**
- Bearing type**
- Material code**
5S: Ceramic rolling elements
No code: Steel rolling elements

HSE type

5S- 2LA-HSE 0 20 AD T2 DB /GL P4

- Cage code**
T2: Polyamide resin cage
No code: Machined phenol resin cage
- Contact angle code**
C: 15°, AD: 25°, No symbol: 20°
- Bore diameter code (See dimension table)**
- Dimension series code**
- Bearing type**
2LA: Special material with improved surface treatment

HSL type

5S- 2LA-HSL 0 20 DB +xx Dn /GL P4 +TKZ

- Spacer code**
(Located beside bearings)
- Spacer code**
(Located between bearings)
- Spacer width dimension**
- Bearing type**

(notes) HSL: Bearing series code
xxDn, +TKZ: Spacer with Eco- friendly nozzle

HSEW type

5S- 2LA-HSEW 0 20 DB /GL P4

- Bearing type**

79LLB/ 70LLB types

5S- 7006 CD LLB DB /GL P42 /L749

- Accuracy class**
P42: Dimensional accuracy = JIS Class 4, running accuracy = JIS Class 2
- Contact angle code**
CD: 15°
AD: 25°

BNS LLB type

5S- 2LA-BNS 0 20 LLB DB /GL P4 /L749

- Grease code**
/L448: Special grease (MP-1)
/L749: Special grease (SE-1)
- Seal code**
LLB: Non-contact rubber seal on both sides
- Bearing type**

BNT type

5S- BNT 0 00 /GN P2

- Bore diameter code (See dimension table)**
- Dimension series code**
- Bearing type**

9.4 Bearing accuracy

Table 9.2 Inner rings

Nominal bore diameter <i>d</i>		Deviation of mean bore diameter in a single plane						Variation of bore diameter in a single plane						Variation of mean bore diameter <i>V_{dmp}</i>			Radial runout of inner ring of assembled bearing <i>K_{ia}</i>					
		Δ_{dmp}						<i>V_{dsp}</i>						<i>V_{dmp}</i>			<i>K_{ia}</i>					
		Class 5		Class 4 ¹⁾		Class 2 ¹⁾		Diameter series 9			Diameter series 0, 2			Class 5			Class 4			Class 2		
mm	incl.	high	low	high	low	high	low	Class 5	Class 4	Class 2	Class 5	Class 4	Class 2	Class 5	Class 4	Class 2	Class 5	Class 4	Class 2	Class 5	Class 4	Class 2
		max						max						max			max					
2.5	10	0	-5	0	-4	0	-2.5	5	4	2.5	4	3	2.5	3	2	1.5	4	2.5	1.5			
10	18	0	-5	0	-4	0	-2.5	5	4	2.5	4	3	2.5	3	2	1.5	4	2.5	1.5			
18	30	0	-6	0	-5	0	-2.5	6	5	2.5	5	4	2.5	3	2.5	1.5	4	3	2.5			
30	50	0	-8	0	-6	0	-2.5	8	6	2.5	6	5	2.5	4	3	1.5	5	4	2.5			
50	80	0	-9	0	-7	0	-4	9	7	4	7	5	4	5	3.5	2	5	4	2.5			
80	120	0	-10	0	-8	0	-5	10	8	5	8	6	5	5	4	2.5	6	5	2.5			
120	150	0	-13	0	-10	0	-7	13	10	7	10	8	7	7	5	3.5	8	6	2.5			
150	180	0	-13	0	-10	0	-7	13	10	7	10	8	7	7	5	3.5	8	6	5			
180	250	0	-15	0	-12	0	-8	15	12	8	12	9	8	8	6	4	10	8	5			

1) The dimensional difference Δ_{ds} of the measured bore diameter applied to Classes 4 and 2 is the same as the tolerance of dimensional difference Δ_{dmp} of the mean bore diameter within a plane. However, the dimensional difference is applied to diameter series 0 and 2 for Class 4, and also to all the diameter series for Class 2.

Table 9.3 Outer rings

Nominal outside diameter <i>D</i>		Deviation of mean outside diameter in a single plane						Variation of outside diameter in a single plane						Variation of mean outside diameter <i>V_{Dmp}</i>			Radial runout of outer ring of assembled bearing <i>K_{ea}</i>					
		Δ_{Dmp}						<i>V_{Dsp}</i>						<i>V_{Dmp}</i>			<i>K_{ea}</i>					
		Class 5		Class 4 ³⁾		Class 2 ³⁾		Diameter series 9			Diameter series 0, 2			Class 5			Class 4			Class 2		
mm	incl.	high	low	high	low	high	low	Class 5	Class 4	Class 2	Class 5	Class 4	Class 2	Class 5	Class 4	Class 2	Class 5	Class 4	Class 2	Class 5	Class 4	Class 2
		max						max						max			max					
18	30	0	-6	0	-5	0	-4	6	5	4	5	4	4	3	2.5	2	6	4	2.5			
30	50	0	-7	0	-6	0	-4	7	6	4	5	5	4	4	3	2	7	5	2.5			
50	80	0	-9	0	-7	0	-4	9	7	4	7	5	4	5	3.5	2	8	5	4			
80	120	0	-10	0	-8	0	-5	10	8	5	8	6	5	5	4	2.5	10	6	5			
120	150	0	-11	0	-9	0	-5	11	9	5	8	7	5	6	5	2.5	11	7	5			
150	180	0	-13	0	-10	0	-7	13	10	7	10	8	7	7	5	3.5	13	8	5			
180	250	0	-15	0	-11	0	-8	15	11	8	11	8	8	8	6	4	15	10	7			
250	315	0	-18	0	-13	0	-8	18	13	8	14	10	8	9	7	4	18	11	7			

3) The dimensional difference Δ_{Ds} of the measured outside diameter applied to Classes 4 and 2 is the same as the tolerance of dimensional difference Δ_{Dmp} of the mean outside diameter within a plane. However, the dimensional difference is applied to diameter series 0 and 2 for Class 4, and also to all the diameter series for Class 2.

Unit: μm

Perpendicularity of inner ring face with respect to the bore			Axial runout of inner ring of assembled bearing			Deviation of a single inner ring width				Variation of inner ring width		
						Δ_{Bs}						
						Single bearing		Duplex bearing ²⁾				
Class 5	Class 4	Class 2	Class 5	Class 4	Class 2	Class 5	Class 4	Class 2	Class 5	Class 4	Class 2	
max			max			high	low	high	low	max		
7	3	1.5	7	3	1.5	0	-40	0	-250	5	2.5	1.5
7	3	1.5	7	3	1.5	0	-80	0	-250	5	2.5	1.5
8	4	1.5	8	4	2.5	0	-120	0	-250	5	2.5	1.5
8	4	1.5	8	4	2.5	0	-120	0	-250	5	3	1.5
8	5	1.5	8	5	2.5	0	-150	0	-250	6	4	1.5
9	5	2.5	9	5	2.5	0	-200	0	-380	7	4	2.5
10	6	2.5	10	7	2.5	0	-250	0	-380	8	5	2.5
10	6	4	10	7	5	0	-250	0	-380	8	5	4
11	7	5	13	8	5	0	-300	0	-500	10	6	5

2) Applies to individual raceway rings manufactured for combined bearing use.

Unit: μm

Perpendicularity of outer ring outside surface with respect to the face			Axial runout of outer ring of assembled bearing			Deviation of a single outer ring width		Variation of outer ring width		
						Δ_{Cs}				
						All classes				
Class 5	Class 4	Class 2	Class 5	Class 4	Class 2	Class 5	Class 4	Class 2		
max			max			max				
8	4	1.5	8	5	2.5	5	2.5	1.5		
8	4	1.5	8	5	2.5	5	2.5	1.5		
8	4	1.5	10	5	4	6	3	1.5		
9	5	2.5	11	6	5	8	4	2.5		
10	5	2.5	13	7	5	8	5	2.5		
10	5	2.5	14	8	5	8	5	2.5		
11	7	4	15	10	7	10	7	4		
13	8	5	18	10	7	11	7	5		

Depends on tolerance of Δ_{Bs} in relation to *d* of the same bearing

9.5 Internal clearance and standard preload of duplex angular contact ball bearings

The initial internal clearance or preload for duplex angular contact ball bearings is determined with consideration for two factors: temperature rise during operation and the rigidity and accuracy required after assembly or during operation.

The internal clearance of the bearing may be significantly affected during operation due to three factors: the reduction in clearance caused by fits, the temperature difference between the inner and outer rings during operation, and the effects of centrifugal force. Depending on the initial internal clearance, a significantly reduced clearance may result in extreme temperature rise, vibration, noise, and short service life. In addition, seizure may result in some cases. For this reason, it is important to determine the optimal initial internal clearance and initial preload required for operation. When using a duplex angular contact ball bearing on the main spindle of a machine tool, the preload is determined by considering the type, main spindle configuration, lubrication system, drive system, intended functions, and other factors. However, preload can also be generalized by the $d_m n$ value [d_m : rolling element pith diameter (mm), n : speed (min^{-1})], as shown below:

- $d_m n$ value $\leq 0.5 \times 10^6$
..... Normal preload (GN)
- $0.5 \times 10^6 < d_m n$ value $\leq 0.65 \times 10^6$
..... Light preload (GL)
- $d_m n$ value $> 0.65 \times 10^6$
..... 0 to positive clearance

For detailed information, contact **NTN** Engineering.

For duplex angular contact ball bearings, **NTN** recommends the initial radial clearances and standard preloads shown in **Table 9.4** through **Table 9.21**. Select the optimal radial internal clearance and initial preload for your application. When ordering a duplex angular contact ball bearing, please specify the desired preload and clearance. If these are not specified in the order, we will ship a bearing with standard clearance. However, some product types do not have a standard clearance. In this case, we will inform you of the available clearances.

Table 9.4 Radial internal clearance of duplex angular contact ball bearings

Unit: μm

Nominal bore diameter d (mm)		C1		C2		CN (normal)	
		over	incl.	min	max	min	max
—	10	3	8	6	12	8	15
10	18	3	8	6	12	8	15
18	30	3	10	6	12	10	20
30	50	3	10	8	14	14	25
50	80	3	11	11	17	17	32
80	100	3	13	13	22	22	40
100	120	3	15	15	30	30	50
120	150	3	16	16	33	35	55
150	180	3	18	18	35	35	60
180	200	3	20	20	40	40	65

■ Standard preloads of angular contact ball bearings (DB and DF arrangements)

Table 9.5 Standard angular contact ball bearings (78C type) Unit: N

Nominal bore diameter d (mm)	Contact angle: 15°		
	78xxC		
	Light preload (GL)	Normal preload (GN)	Medium preload (GM)
25	10	29	78
30	10	29	78
35	10	29	78
40	10	29	78
45	20	49	98
50	20	49	98
55	29	98	196
60	29	98	196
65	29	98	196
70	29	98	196
75	29	98	196
80	29	98	196
85	49	147	294
90	49	147	294
95	49	147	294
100	49	147	294
105	49	147	294
110	78	196	490
120	78	196	490
130	98	294	590
140	98	294	590
150	147	390	785
160	147	390	785
170	147	490	980

Table 9.6 Standard angular contact ball bearings (79 type)

Unit: N

Nominal bore diameter <i>d</i> (mm)	Contact angle: 15°			Contact angle: 25°			Contact angle: 30°		
	79xxUC/5S-79xxUC			79xxUAD/5S-79xxUAD			79xxU/5S-79xxU		
	Light preload (GL)	Normal preload (GN)	Medium preload (GM)	Light preload (GL)	Normal preload (GN)	Medium preload (GM)	Light preload (GL)	Normal preload (GN)	Medium preload (GM)
10	—	20	39	—	29	59	—	39	78
12	—	20	39	—	29	69	—	39	78
15	—	29	59	—	49	98	20	59	118
17	—	29	69	20	49	98	20	69	127
20	20	49	88	20	69	147	29	88	186
25	20	49	98	20	78	157	29	98	196
30	20	49	108	20	78	167	29	98	206
35	29	78	167	39	127	255	49	167	325
40	29	88	177	39	137	275	49	167	345
45	39	108	216	49	167	345	69	216	420
50	39	118	226	49	177	355	69	226	450
55	39	118	235	59	186	375	69	235	460
60	39	127	245	59	196	380	78	245	480
65	39	127	245	59	196	390	78	245	490
70	59	177	365	88	284	560	108	355	695
75	59	177	365	88	284	570	108	355	705
80	59	186	365	88	284	580	108	365	715
85	78	245	490	118	390	775	147	480	970
90	88	255	500	118	390	785	147	490	980
95	88	255	510	118	400	795	157	500	990
100	108	325	655	157	510	1 020	196	635	1 270
105	108	335	655	157	520	1 040	196	645	1 300
110	108	335	665	157	530	1 060	206	655	1 310
120	137	410	835	196	655	1 300	245	815	1 620
130	167	510	1 020	235	805	1 600	305	990	1 990
	79xxC								
140	196	490	980						
150	245	685	1 470						
160	245	685	1 470						
170	245	685	1 470						

Table 9.7 Standard angular contact ball bearings (70 type)

Unit: N

Nominal bore diameter <i>d</i> (mm)	Contact angle: 15°			Contact angle: 25°			Contact angle: 30°		
	70xxUC/5S-70xxUC			70xxUAD/5S-70xxUAD			70xxU/5S-70xxU		
	Light preload (GL)	Normal preload (GN)	Medium preload (GM)	Light preload (GL)	Normal preload (GN)	Medium preload (GM)	Light preload (GL)	Normal preload (GN)	Medium preload (GM)
10	—	29	59	20	49	108	20	69	127
12	—	39	69	20	59	108	20	69	137
15	—	39	78	20	59	127	29	78	157
17	20	49	98	20	78	157	29	98	196
20	20	69	137	29	108	216	39	137	265
25	29	78	147	39	118	235	49	147	294
30	29	98	186	49	147	305	59	186	375
35	39	118	235	59	186	380	69	235	480
40	39	127	255	59	206	400	78	255	510
45	49	147	305	69	245	480	88	305	600
50	49	157	325	78	255	510	98	325	635
55	69	216	420	98	335	665	127	420	845
60	69	216	430	108	345	685	127	430	855
65	78	226	460	108	365	725	137	450	900
70	98	294	580	137	460	920	177	580	1 150
75	98	294	600	137	470	940	177	590	1 180
80	118	365	725	177	580	1 150	216	715	1 430
85	127	375	745	177	590	1 180	226	735	1 470
90	147	440	890	206	705	1 400	265	875	1 750
95	157	460	910	216	715	1 430	275	900	1 790
100	157	460	930	226	735	1 470	284	920	1 830
105	186	550	1 090	255	865	1 720	335	1 070	2 140
110	206	630	1 250	294	990	1 980	380	1 230	2 460
120	216	635	1 270	305	1 010	2 020	380	1 260	2 510
130	265	805	1 600	380	1 270	2 530	480	1 570	3 150
140	275	815	1 640	380	1 280	2 570	490	1 610	3 200
	70xxC								
150	294	785	1 960						
160	490	980	2 450						
170	490	980	2 450						
180	490	980	2 450						
190	590	1 470	3 450						
200	590	1 470	3 450						

Table 9.8 Standard angular contact ball bearings (72C type)

Unit: N

Nominal bore diameter <i>d</i> (mm)	Contact angle: 15°		
	72xxC		
	Light preload (GL)	Normal preload (GN)	Medium preload (GM)
10	20	49	98
12	20	49	98
15	20	49	147
17	20	49	147
20	49	98	294
25	49	98	294
30	49	98	294
35	78	196	490
40	78	196	490
45	98	294	590
50	98	294	590
55	147	390	785
60	147	390	785
65	147	390	785
70	196	490	980
75	196	490	980
80	196	490	980
85	294	685	1 470
90	294	685	1 470
95	294	685	1 960
100	294	685	1 960
105	390	980	2 450
110	390	980	2 450
120	390	980	2 450
130	490	1 470	2 940

Main Spindle Bearings

Main Spindle Bearings

Table 9.9 High speed angular contact ball bearings (HSE9 type) Unit: N

Nominal bore diameter <i>d</i> (mm)	Contact angle: 15°			Contact angle: 20°			Contact angle: 25°		
	HSE9xxUC/5S-HSE9xxUC			HSE9xxU/5S-HSE9xxU			HSE9xxUAD/5S-HSE9xxUAD		
	Light preload (GL)	Normal preload (GN)	Medium preload (GM)	Light preload (GL)	Normal preload (GN)	Medium preload (GM)	Light preload (GL)	Normal preload (GN)	Medium preload (GM)
50	34	88	177	39	127	255	39	177	345
55	44	108	216	49	157	345	49	216	440
60	44	118	226	49	167	345	54	226	440
65	44	118	226	49	167	345	54	226	440
70	69	167	345	74	245	490	78	345	685
75	69	177	345	74	255	490	83	345	685
80	69	177	345	74	255	540	83	345	685
85	98	235	490	98	345	685	108	490	930
90	98	245	490	108	345	735	118	490	980
95	98	255	490	108	345	735	118	490	980
100	118	294	590	127	440	835	137	590	1 180
105	118	294	590	127	440	885	137	590	1 180
110	118	294	590	127	440	885	137	590	1 180
120	157	390	785	167	540	1 080	177	785	1 570
130	186	490	930	196	685	1 370	226	930	1 860
140	186	490	930	206	685	1 370	226	930	1 860
150	255	635	1 270	275	930	1 860	294	1 270	2 550
160	255	635	1 270	275	930	1 860	294	1 270	2 550
170	255	635	1 270	275	930	1 860	294	1 270	2 550

Table 9.10 High speed angular contact ball bearings (HSE0 type) Unit: N

Nominal bore diameter <i>d</i> (mm)	Contact angle: 15°			Contact angle: 20°			Contact angle: 25°		
	HSE0xxC/5S-HSE0xxC			HSE0xx/5S-HSE0xx			HSE0xxAD/5S-HSE0xxAD		
	Light preload (GL)	Normal preload (GN)	Medium preload (GM)	Light preload (GL)	Normal preload (GN)	Medium preload (GM)	Light preload (GL)	Normal preload (GN)	Medium preload (GM)
50	59	157	315	69	235	460	78	305	600
55	69	177	345	78	255	510	78	325	645
60	69	186	365	78	265	530	88	345	685
65	69	186	365	78	265	540	88	345	695
70	88	226	450	98	325	655	108	420	845
75	98	235	480	108	355	695	118	450	900
80	108	275	550	118	400	805	127	520	1 030
85	108	275	560	118	400	815	127	520	1 040
90	127	325	645	137	470	940	157	610	1 220
95	127	325	645	147	480	960	157	620	1 240
100	137	345	675	147	490	990	157	635	1 270
105	157	390	775	167	570	1 140	186	725	1 450
110	196	480	960	206	695	1 400	226	900	1 800
120	196	480	960	216	705	1 410	226	910	1 820
130	275	695	1 380	305	1 020	2 030	325	1 300	2 610
140	284	715	1 430	315	1 050	2 090	345	1 350	2 710
150	294	735	1 470	325	1 080	2 150	345	1 380	2 770
160	345	865	1 730	375	1 260	2 520	410	1 630	3 250
170	390	990	1 980	430	1 450	2 900	470	1 860	3 750

Table 9.11 Eco-friendly air-oil lubricated angular contact ball bearings (HSL9 type) Unit: N

Nominal bore diameter <i>d</i> (mm)	Contact angle: 20°			Contact angle: 25°		
	5S-HSL9xxU			5S-HSL9xxUAD		
	Light preload (GL)	Normal preload (GN)	Medium preload (GM)	Light preload (GL)	Normal preload (GN)	Medium preload (GM)
50	39	127	255	39	177	345
55	49	157	345	49	216	440
60	49	167	345	54	226	440
65	49	167	345	54	226	440
70	74	245	490	78	345	685
75	74	255	490	83	345	685
80	74	255	540	83	345	685
85	98	345	685	108	490	930
90	108	345	735	118	490	980
95	108	345	735	118	490	980
100	127	440	835	137	590	1 170
105	127	440	885	137	590	1 170
110	127	440	885	137	590	1 170
120	167	540	1 080	177	785	1 570
130	196	685	1 370	226	930	1 860

Table 9.12 Eco-friendly air-oil lubricated angular contact ball bearings (HSL0 type) Unit: N

Nominal bore diameter <i>d</i> (mm)	Contact angle: 20°			Contact angle: 25°		
	5S-HSL0xx			5S-HSL0xxAD		
	Light preload (GL)	Normal preload (GN)	Medium preload (GM)	Light preload (GL)	Normal preload (GN)	Medium preload (GM)
50	69	235	460	78	305	600
55	78	255	510	78	325	645
60	78	265	530	88	345	685
65	78	265	540	88	345	695
70	98	325	655	108	420	845
75	108	355	695	118	450	900
80	118	400	805	127	520	1 030
85	118	400	815	127	520	1 040
90	137	470	940	157	610	1 220
95	147	480	960	157	620	1 240
100	147	490	990	157	635	1 270
105	167	570	1 140	186	725	1 450
110	206	695	1 400	226	900	1 800
120	216	705	1 410	226	910	1 820
130	305	1 020	2 030	325	1 300	2 610

Table 9.13 Air-oil lubricated high speed angular contact ball bearings with re-lubricating hole on the outer ring (HSEW9U type) Unit: N

Nominal bore diameter <i>d</i> (mm)	Contact angle: 20°			Contact angle: 25°		
	5S-HSEW9xxU			5S-HSEW9xxUAD		
	Light preload (GL)	Normal preload (GN)	Medium preload (GM)	Light preload (GL)	Normal preload (GN)	Medium preload (GM)
50	39	127	255	39	177	345
55	49	157	345	49	216	440
60	49	167	345	54	226	440
65	49	167	345	54	226	440
70	74	245	490	78	345	685
75	74	255	490	83	345	685
80	74	255	540	83	345	685
85	98	345	685	108	490	930
90	108	345	735	118	490	980
95	108	345	735	118	490	980
100	127	440	835	137	590	1 170

Main Spindle Bearings

Main Spindle Bearings

Table 9.14 Air-oil lubricated high speed angular contact ball bearings with re-lubricating hole on the outer ring (HSEW0 type) Unit: N

Nominal bore diameter d (mm)	Contact angle: 20°			Contact angle: 25°		
	5S-HSEW0xx			5S-HSEW0xxAD		
	Light preload (GL)	Normal preload (GN)	Medium preload (GM)	Light preload (GL)	Normal preload (GN)	Medium preload (GM)
50	69	235	460	78	305	600
55	78	255	510	78	325	645
60	78	265	530	88	345	685
65	78	265	540	88	345	695
70	98	325	655	108	420	845
75	108	355	695	118	450	900
80	118	400	805	127	520	1 030
85	118	400	815	127	520	1 040
90	137	470	940	157	610	1 220
95	147	480	960	157	620	1 240
100	147	490	990	157	635	1 270

Table 9.15 Grease-lubricated sealed standard angular contact ball bearings (79CD and AD types) Unit: N

Nominal bore diameter d (mm)	Contact angle: 15°			Contact angle: 25°		
	79xxCD/5S-79xxCD			79xxAD/5S-79xxAD		
	Light preload (GL)	Normal preload (GN)	Medium preload (GM)	Light preload (GL)	Normal preload (GN)	Medium preload (GM)
10	10	29	78	—	39	78
12	10	29	78	—	39	78
15	10	29	78	—	49	147
17	10	29	78	—	49	147
20	20	49	98	29	98	196
25	20	49	98	29	98	196
30	20	49	98	29	98	196
35	29	78	196	49	147	294
40	29	78	196	49	147	294
45	39	98	245	49	196	390
50	39	98	245	49	196	390

Table 9.16 Grease-lubricated sealed standard angular contact ball bearings (70CD and AD types) Unit: N

Nominal bore diameter d (mm)	Contact angle: 15°			Contact angle: 25°		
	70xxCD/5S-70xxCD			70xxAD/5S-70xxAD		
	Light preload (GL)	Normal preload (GN)	Medium preload (GM)	Light preload (GL)	Normal preload (GN)	Medium preload (GM)
10	20	29	98	29	78	147
12	20	29	98	29	78	147
15	20	29	98	29	78	147
17	20	29	98	29	78	147
20	29	78	147	49	147	294
25	29	78	147	49	147	294
30	29	78	147	49	147	294
35	49	147	294	78	294	590
40	49	147	294	78	294	590
45	49	147	294	78	294	590
50	49	147	294	78	294	590

Table 9.17 Grease-lubricated sealed high speed angular contact ball bearings (BNS9 type) Unit: N

Nominal bore diameter d (mm)	Contact angle: 15°			Contact angle: 20°			Contact angle: 25°		
	BNS9xxC/5S-BNS9xxC			BNS9xx/5S-BNS9xx			BNS9xxAD/5S-BNS9xxAD		
	Light preload (GL)	Normal preload (GN)	Medium preload (GM)	Light preload (GL)	Normal preload (GN)	Medium preload (GM)	Light preload (GL)	Normal preload (GN)	Medium preload (GM)
50	29	78	167	39	118	235	39	157	305
55	39	108	206	49	147	305	49	196	390
60	39	108	216	49	157	315	49	196	400
65	39	108	216	49	157	315	49	206	410
70	59	137	275	59	196	400	69	255	520
75	59	137	284	59	206	410	69	265	530
80	59	147	294	59	216	420	69	275	550
85	69	177	345	78	255	510	78	325	655
90	69	177	355	78	265	520	88	335	665
95	69	186	365	78	265	540	88	345	685
100	98	255	510	108	375	755	118	480	970

Table 9.18 Grease-lubricated sealed high speed angular contact ball bearings (BNS0 type) Unit: N

Nominal bore diameter d (mm)	Contact angle: 15°			Contact angle: 20°			Contact angle: 25°		
	BNS0xxC/5S-BNS0xxC			BNS0xx/5S-BNS0xx			BNS0xxAD/5S-BNS0xxAD		
	Light preload (GL)	Normal preload (GN)	Medium preload (GM)	Light preload (GL)	Normal preload (GN)	Medium preload (GM)	Light preload (GL)	Normal preload (GN)	Medium preload (GM)
45	49	118	235	49	177	345	59	226	450
50	59	157	315	69	235	460	78	305	600
55	69	177	345	78	255	510	78	325	645
60	69	186	365	78	265	530	88	345	685
65	69	186	365	78	265	540	88	345	695
70	88	226	450	98	325	655	108	420	845
75	98	235	480	108	355	695	118	450	900
80	108	275	550	118	400	805	127	520	1 030
85	108	275	560	118	400	815	127	520	1 040
90	127	325	645	137	470	940	157	610	1 220
95	127	325	645	147	480	960	157	620	1 240
100	137	345	675	147	490	990	157	635	1 270

Table 9.19 Angular contact ball bearings for grinding machines/motors (BNT9 type) Unit: N

Nominal bore diameter d (mm)	Contact angle: 15°		
	BNT9xx/5S-BNT9xx		
	Light preload (GL)	Normal preload (GN)	Medium preload (GM)
10	10	29	78
12	10	29	78
15	10	29	78
17	10	29	78
20	20	49	98
25	20	49	98
30	20	49	98
35	29	78	196
40	29	78	196
45	39	98	245
50	39	98	245
55	49	118	294
60	49	118	294
65	49	118	294

Table 9.20 Angular contact ball bearings for grinding machines/motors (BNT0 type) Unit: N

Nominal bore diameter d (mm)	Contact angle: 15°		
	BNT0xx/5S-BNT0xx		
	Light preload (GL)	Normal preload (GN)	Medium preload (GM)
10	20	29	98
12	20	29	98
15	20	29	98
17	20	29	98
20	29	78	147
25	29	78	147
30	29	78	147
35	49	147	294
40	49	147	294
45	49	147	294
50	49	147	294
55	98	196	490
60	98	196	490
65	98	196	490
70	98	294	685

Table 9.21 Angular contact ball bearings for grinding machines/motors (BNT2 type) Unit: N

Nominal bore diameter d (mm)	Contact angle: 15°		
	BNT2xx/5S-BNT2xx		
	Light preload (GL)	Normal preload (GN)	Medium preload (GM)
10	20	49	98
12	20	49	98
15	20	49	147
17	20	49	147
20	49	98	294
25	49	98	294
30	49	98	294
35	78	196	490
40	78	196	490
45	98	294	590
50	98	294	590
55	147	390	785
60	147	390	785
65	147	390	785
70	196	490	980
75	196	490	980
80	196	490	980

Main Spindle Bearings

Main Spindle Bearings

9.6 Recommended fits for angular contact ball bearings

If the d_{mn} value is in the range of $d_{mn} \leq 0.75 \times 10^6$ [d_m : rolling element pith diameter (mm), n : speed (min^{-1})], the fit values shown in **Table 9.22** and **Table 9.23** are recommended to ensure high accuracies of precision bearings.

If the d_{mn} value is in the range of $d_{mn} > 0.75 \times 10^6$, it is necessary to consider expansion of inner ring caused by centrifugal force. In this case, contact **NTN Engineering** for the recommended fits. As for the fit of the outer ring with the housing, consider the influence of the ambient temperature (such as heat buildup on a built-in motor or the cooling effect of jacket). For technical assistance, contact **NTN Engineering**.

Table 9.22 Shaft fits Unit: μm

Nominal bore diameter d (mm)		Fits of inner ring with shaft
Over	Incl.	
2.5	10	0-2T
10	18	0-2T
18	30	0-2T
30	50	0-3T
50	80	1T-4T
80	120	1T-5T
120	180	2T-7T
180	250	2T-8T

Notes: 1. The mean value should be the target value.
 2. If the d_{mn} value of the high speed machine is in the range of $d_{mn} > 0.75 \times 10^6$, it is necessary to increase the amount of interference. In this case, contact **NTN Engineering** for technical assistance.
 T: Tight (Interference) fit

Table 9.23 Housing fits Unit: μm

Nominal outside diameter D (mm)		Fits of outer ring with housing	
Over	Incl.	Bearing on fixed side	Bearing on free side
		10	50
50	80	3L- 7L	6L-12L
80	120	4L- 9L	8L- 13L
120	150	5L-11L	10L-16L
150	180	6L-13L	11L-17L
180	250	7L-15L	13L-20L
250	315	8L-17L	15L-23L

Notes: 1. The mean value should be the target value.
 2. If the d_{mn} value is in the range of $d_{mn} > 1.0 \times 10^6$, spacer width and bearing arrangement, it is necessary to increase the amount of interference. In this case, contact **NTN Engineering** for technical assistance.
 L: Loose fit

9.7 Duplex angular contact ball bearings

Duplex angular contact ball bearings can be combined in rows of two, three or four bearings to accommodate required specifications.

The back-to-back duplex (DB) arrangement and the face-to-face duplex (DF) arrangement allow for the application of both radial loads and axial loads in both directions. The DB arrangement has a wide space between load points and can handle large moment loads. For this reason, this type of duplex arrangement is preferable for use on the main spindles of machine tools.

The DF arrangement cannot handle large moment loads, but its allowable inclination angle is greater than that of the DB arrangement. The tandem duplex (DT) arrangement can handle both a radial load and large axial load, but this bearing can take the axial load in one direction only. The 4-row duplex (type DTBT) arrangement ensures high rigidity in the radial and axial directions and accommodates high speed operation. For this reason, this type of duplex bearing is commonly used for the main spindles of machining centers.

Each duplex angular contact ball bearing is manufactured as a set to enable adjustment of the preload and clearance. For this reason, combine only duplex bearings of the same product number.

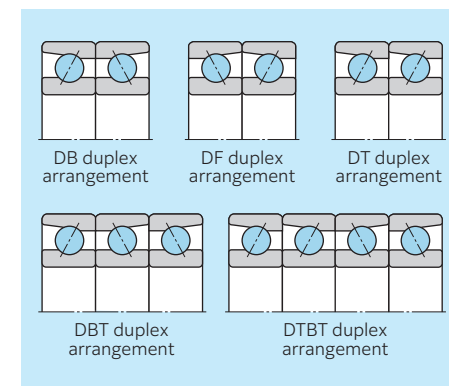

Fig. 9.10

9.8 Duplex arrangement codes of duplex angular contact ball bearings

Duplex angular contact ball bearings have a product number and duplex arrangement code on the side of the bearing (see Fig. 9.11). Duplex angular contact ball bearings of 3 rows or more have a “<” mark on the outside diameter surface of the bearing. Always ensure that the “<” mark is aligned when assembling them (see Fig. 9.12). Additionally, face-to-face duplex (DF) and back-to-back duplex (DB) angular contact ball bearings do not have the “<” mark, so use the duplex arrangement code to match them.

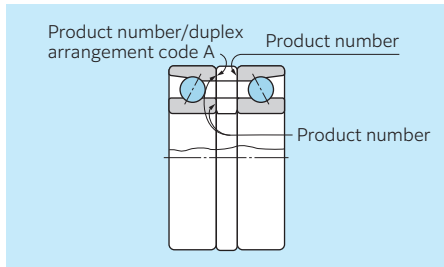

Fig. 9.11

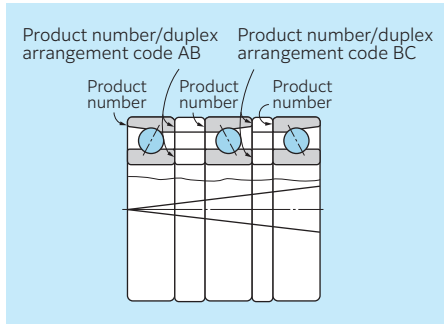

Fig. 9.12

9.9 Flush ground and universal matching

Angular contact ball bearings are often combined for a special purpose. Face-to-face duplex (DF) arrangement, back-to-back duplex (DB) arrangement and tandem duplex (DT) arrangement may be combined in rows of two or more. When combining many bearings, it is important to control the accuracies of the bearings and to align their face heights in a common plane.

■ Flush ground

“Flush ground” is a finishing technique in which the front and back faces of the inner and outer rings are aligned with each other to eliminate differences in face height (see Fig. 9.13). Such alignment can ensure the specified clearance and preload for DF, DB, and DT sets, but it is possible only if the combined bearings have the same clearance/preload symbols. Flush ground is provided as standard on BNT type angular contact ball bearings for grinding machines/motors as well as BST and 2A-BST type angular contact thrust ball bearings for ball screw support.

Note: The flush ground technique is also adopted for other types of angular contact ball bearings. When ordering a bearing, append “G” to the product number to specify the flush ground type.
Example: 7010UC G /GNP4

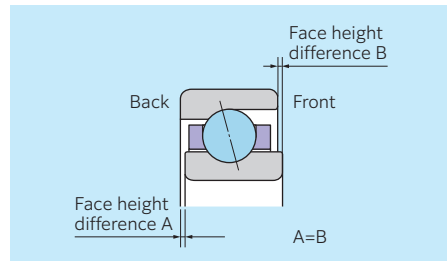

Fig. 9.13 Flush ground

■ Universal Matching

In addition to the flush ground technique, universal matching is employed for duplex angular contact ball bearings. Universal matching controls the bearing-to-bearing dimensional differences in the bore and outside diameters.

NTN can control the bearing-to-bearing difference in the bore and outside diameters to no more than one-third the tolerance (a minimum of 2 μm). Universal matching

is adopted for duplex angular contact ball bearings of JIS Class 5 or better. When ordering a bearing, specify the desired number of duplex bearings to be used in combination (“D2” for DB, DF or DT; and “D3” for DBT, DFT or DTT). Alternately, indicate the basic combination and specify universal matching.

If two duplex bearings are combined, “D2” is appended to the product number.

Example: 7010UC G D2 /GNP4

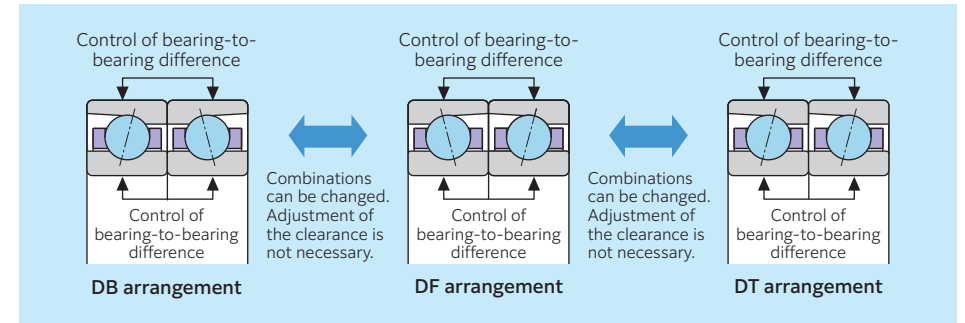

Fig. 9.14 Universal matching

9.10 Angular contact ball bearings with ceramic balls

Recently, the main spindles of machining centers, NC machines and other machine tools have been required to operate at much higher speeds. Bearings for main spindles therefore must meet the requirements of high speed and rigidity as well as accuracy. To meet such requirements, many of our customers want the rolling element made of ceramic material. The features of angular contact ball bearings with ceramic balls are described below.

■ Limited temperature rise and ultra high speeds

The specific gravity of ceramic material is one-half that of bearing steel. In addition, the ball diameter of 5S-HSE type is smaller than that of the standard 70 type. For this reason, use of ceramic balls greatly reduces the influence of centrifugal force (ball sliding and spinning caused by gyratory moment).

The linear expansion coefficient for ceramics can be as low as a 1/4 of that for bearing steel. This will reduce the increase in preload at high speeds due to a fixed position preload.

As a result, these angular contact ball bearings inhibit temperature buildup and ensure high speed.

■ High bearing rigidity for high accuracy of manufactured products

The Young's modulus of ceramic material is approximately 1.5 times that of bearing steel, which increases bearing rigidity and can be expected to improve the precision of the workpiece.

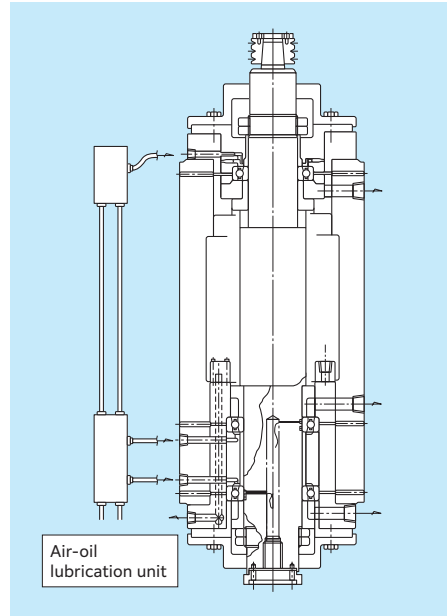

Fig. 9.16 Test rig for measuring temperature rise

Table 9.24 Comparison of physical properties between ceramic and steel balls

Item	Ceramic (Si ₃ N ₄)	Bearing steel (SUJ2)
Density (g/cm ³)	3.24	7.83
Young's modulus (GPa)	308	208
Poisson's ratio	0.25	0.3
Linear expansion coefficient (×10 ⁻⁶ /°C)	3.0	12.5
Thermal conductivity (W/m · °C)	20	46

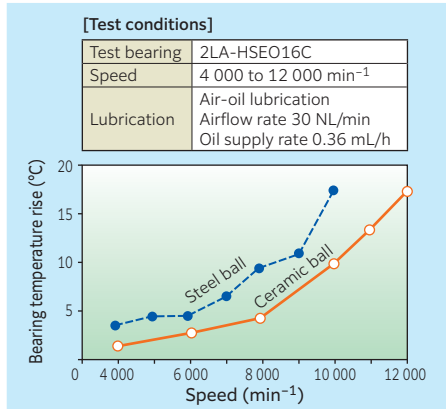

Fig. 9.15 Comparison of temperature rise between bearings with ceramic balls and those with steel balls

9.11 Operating life of bearings with ceramic balls

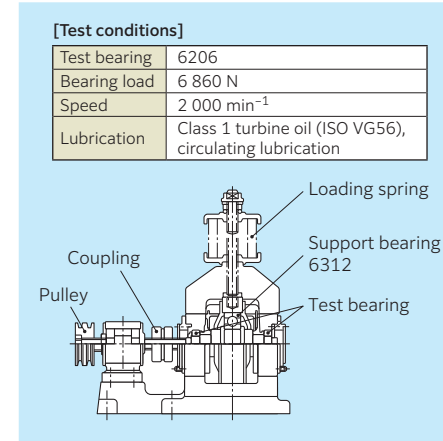

Fig. 9.17 Radial load-type bearing life test machine

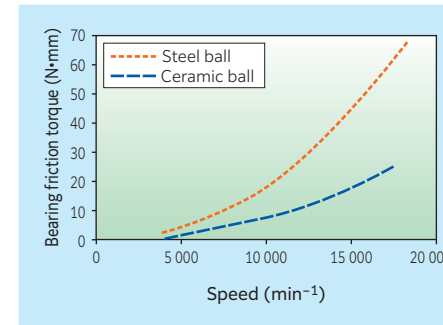

Fig. 9.19 Bearing friction torque

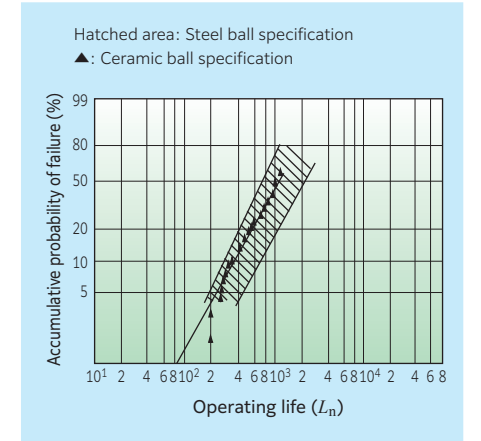

Fig. 9.18 Operating life of ball bearing with ceramic balls

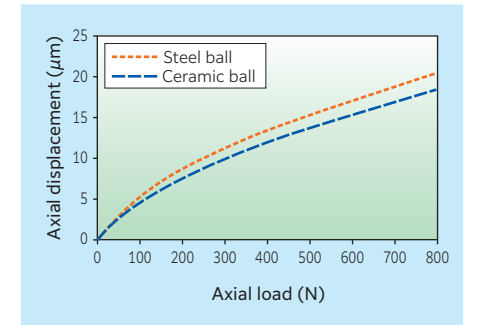

Fig. 9.20 Axial rigidity diagram

9.12 Recommended lubrication specifications

Angular contact ball bearings are usually used with grease lubrication or air-oil lubrication. Recommended lubrication specifications are described below.

■ Grease lubrication

● Recommended brand of grease

Refer to 7. Lubrication of Bearings, 7.1 Grease lubrication in the Technical Data section.

● Recommended grease fill

d_{mn} value $\leq 0.65 \times 10^6$

15 to 20 % of the capacity shown in the dimension tables

d_{mn} value $> 0.65 \times 10^6$

12 to 17 % of the capacity shown in the dimension tables

● Recommended grease filling method

Refer to 6. Handling of Bearings, 6.1 Cleaning and filling with grease in the Technical Data section.

● Notes

Grease-lubricated sealed angular contact ball bearings (79 LLB/70 LLB types, and BNS type bearings) are prefilled with long-life SE-1 grease. Wipe rust preventive oil from the outside of the bearing with a clean cloth.

■ Air-oil lubrication

● Recommended location of nozzle

Refer to 7. Lubrication of Bearings, 7.2 Air-oil lubrication in the Technical Data section.

● Recommended specifications of nozzle

Nozzle bore dia.: From 1 to 1.5 mm

Number of nozzles: One nozzle per bearing, depth of nozzle bore should be four to six times as large as the bore diameter.

● Recommended specifications of air-oil

Oil type: Spindle oil

Viscosity grade: ISO VG from 22 to 32 (32 is preferable)

Table 9.25 Air and oil amount

Bearing type	d_{mn} value ($\times 10^6$)		Oil volume per shot mL	Lubrication intervals min	Oil consumption mL/h	Recommended air consumption NL/min ¹⁾
	Over	Incl.				
78C, 79U, 70U, 72C	—	1.0	0.03	8	0.23	20 to 40
HSE9U, HSE0	1.0	1.5		5	0.36	
HSF	1.5	2.6		2	0.90	
HSEW	—	2.2		10	0.18	
HSL	—	2.6				
HSFL	—	2.6				

1) NL/min (Normal liter/minute) --- NL means the volume of air at 0 °C and 1 atmosphere.

Note) The amount of oil and air needs to be adjusted to suit the spindle structure or the differences in discharge channels.

Set the amounts after checking with actual machine tests.

9.13 **ULTAGE** Standard angular contact ball bearings 79U and 70U types

ULTAGE series 79U and 70U types bearings were developed from standard angular contact ball bearings (79 and 70). Optimized internal design and adoption of a new resin cage allows high speed operation and ensures high rigidity.

■ Features

1. Optimized internal design enables high speed operation and high rigidity.
2. A new resin cage enables improvement in grease retention for grease lubrication and enhanced performance in feeding and discharge of oil for air-oil lubrication.
3. Bearings are available with either steel or ceramic balls.
4. Three contact angles (15°, 20°, and 30°) are available to handle a wide range of applications.

■ Bearing specification

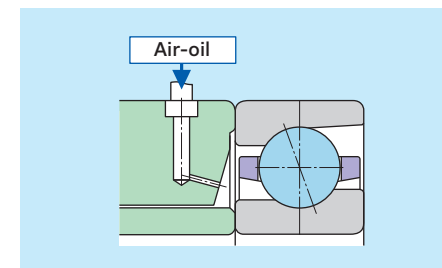

Fig. 9.21 79U and 70U types



Photo 9.1 New resin cage

■ Data

Optimized internal design and adoption of a new resin cage enable stable operation at d_{mn} value 0.95×10^6 , with grease lubrication.

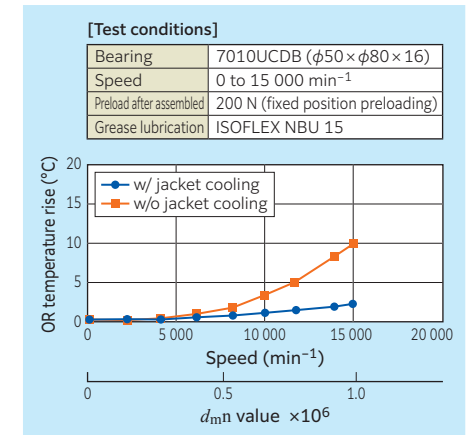

Fig. 9.22 High speed test with grease lubrication

Stable operation is possible with d_{mn} value 1.5×10^6 , with air-oil lubrication.

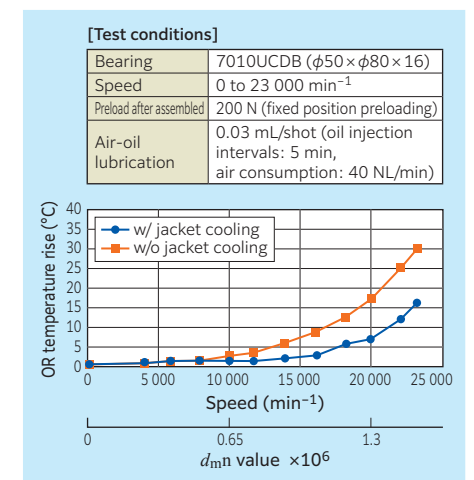
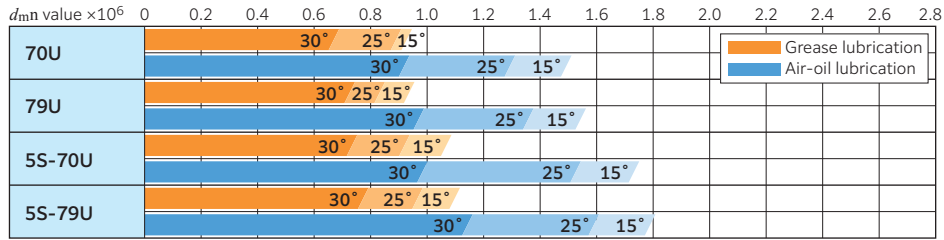

Fig. 9.23 High speed test with air-oil lubrication

Permissible speed range



Notes) Permissible speed of each bearing (d_{mn} value) varies depending on the specifications of the machine on which the bearing is used (motor drive system, cooling system, and construction around the bearing). Consider the optimal choice referring to the above guideline (for two-row arrangement), and then, contact NTN Engineering for technical assistance.

9.14 ULTAGE High speed angular contact ball bearings HSE type

The HSE type employs a special material featuring greatly improved wear resistance and anti-seizure properties as well as a special surface modification technique. Furthermore, thanks to an optimized internal design, this type achieves high speed, high rigidity and high reliability.

Features

1. Adoption of special materials and a unique internal design improve anti-seizure properties (15 times better than the conventional type) and wear resistance (1/6 reduction compared the conventional type).
2. Optimized internal design enables high speed operation and high rigidity.
3. Bearings are available with either steel or ceramic balls.
4. Three contact angles (15°, 20°, and 25°) are available to handle a wide range of applications.

Bearing specification

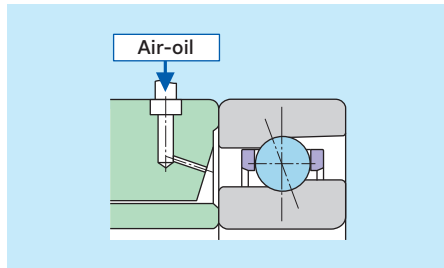

Fig. 9.24 HSE type

Data 1

The 5S-HSE type features high speed and limited temperature rise. Even if its preload is increased after assembly into the spindle, it maintains stable performance at high speeds (see Fig. 9.25).

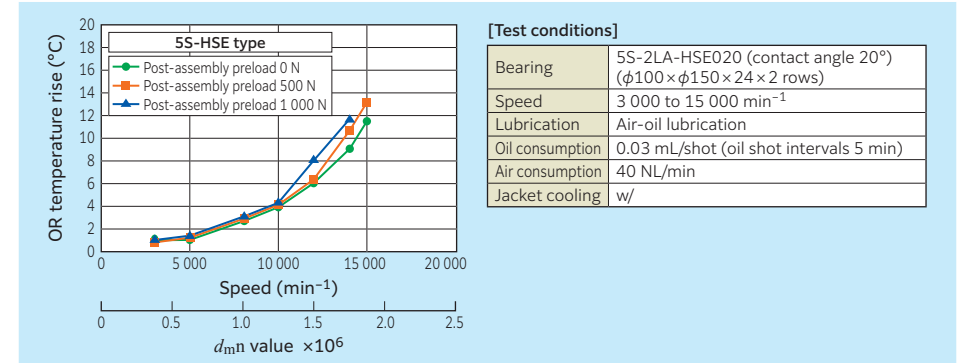

Fig. 9.25 Relationship between preload and temperature rise

Data 2

When built into a high speed main spindle, the preload of the 5S-HSE type is maintained, allowing high rigidity (1.9 times greater than a conventional bearing) (see Fig. 9.26).

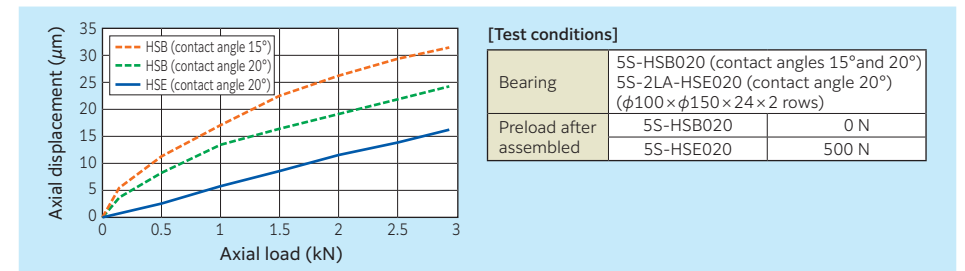
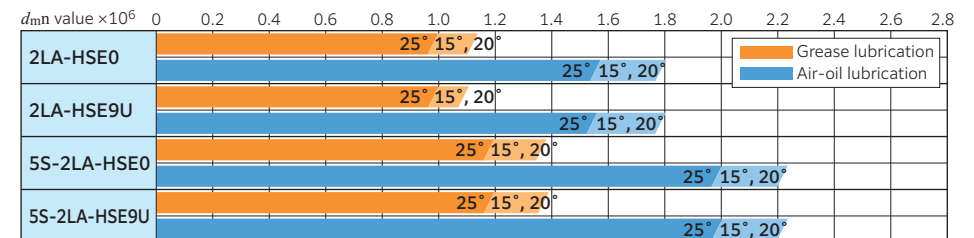

Fig. 9.26 Comparison of rigidity relative to conventional bearing (HSB type) in terms of preload after assembled

Permissible speed range



Notes) Permissible speed of each bearing (d_{mn} value) varies depending on the specifications of the machine on which the bearing is used (motor drive system, cooling system, and construction around the bearing). Consider the optimal choice referring to the above guideline (for two-row arrangement), and then, contact NTN Engineering for technical assistance.

9.15 **ULTAGE** Ultra high speed angular contact ball bearings HSF type

The HSF type realizes further improvement in high speed running and inhibited temperature rise by adoption of smaller diameter ceramic balls, while retaining features of the HSE type. This type attains d_{mn} values as high as 2.6×10^6 with fixed pressure preloading.

■ Features

1. Adoption of special materials and a unique internal design improve anti-seizure property (15 times better than the conventional type) and wear resistance (1/6 reduction compared the conventional type).
2. Optimized internal design enables high speed operation and high rigidity.
3. Ceramic balls are used.
4. Initial contact angle is set to 25° to accommodate the change in contact angle during ultra high speed operation.

■ Bearing specification

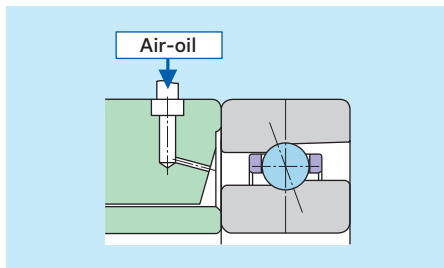
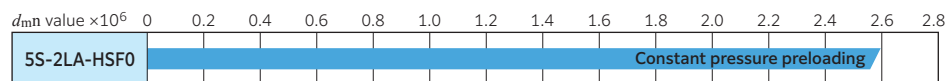

Fig. 9.27 HSF type

■ Permissible speed range



Notes) Permissible speed of each bearing (d_{mn} value) varies depending on the specifications of the machine on which the bearing is used (motor drive system, cooling system, and construction around the bearing). Consider the optimal choice referring to the above guideline (for two-row arrangement), and then, contact **NTN** Engineering for technical assistance.

■ Low temperature rise

Ultra high speed 5S-HSF type angular contact ball bearings utilize smaller balls than those of the high speed HSE type. This reduces heating due to centrifugal force and ensures lower temperature rise. Thus, the 5S-HSF type boasts an approximately 10 % reduction in temperature rise as compared to the 5S-HSE type (see Fig. 9.28).

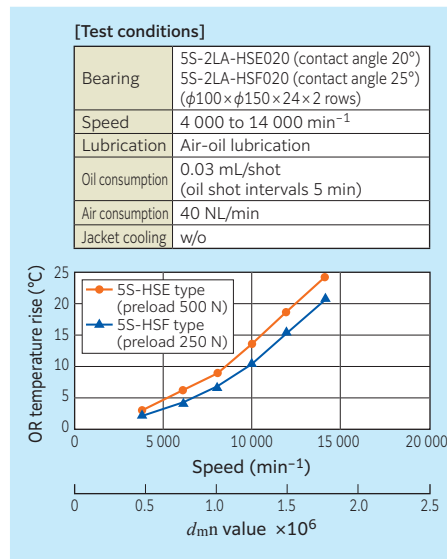
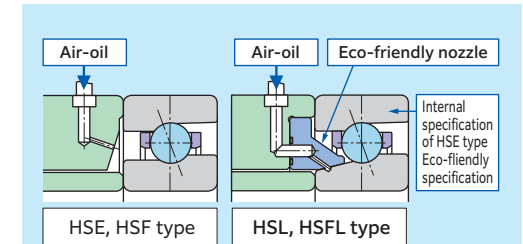

Fig. 9.28 Comparison of temperature rise

9.16 **ULTAGE** Eco-friendly air-oil lubricated angular contact ball bearings HSL type, HSFL type

The HSL/HSFL type is an advanced variation of the HSE/HSF type, characterized by incorporation of **NTN's** unique eco-conscious lubrication technology. The HSL type helps decrease oil mist emissions and consumption of air and oil, improving the working environment for machine tool operators and reducing energy consumption.

■ Bearing specification



NOTE) The HSL/HSFL type is packed together with the spacer with the eco-friendly nozzle. The bearing type code HSL represents the bearing proper, while a spacer code stands for an eco-conscious nozzle proper or a spacer having a built-in nozzle. For more details, see "9.3 Bearing Designation".

■ Features

1. Adoption of special materials and a unique internal design improve anti-seizure properties (15 times better compared with the conventional type) and wear resistance (1/6 reduction compared the conventional type).
2. Ceramic balls are used.
3. Adoption of eco-friendly nozzle reduces noise (reduction of 2 to 8 dBA), air consumption (reduction of 50 to 75 %) and oil consumption (reduction of 20 to 90 %)

■ Permissible speed range

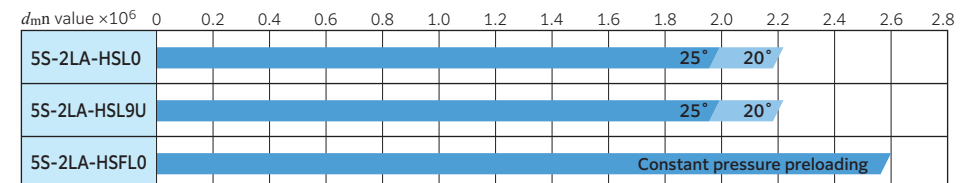

Notes) Permissible speed of each bearing (d_{mn} value) varies depending on the specifications of the machine on which the bearing is used (motor drive system, cooling system, and construction around the bearing). Consider the optimal choice referring to the above guideline (for two-row arrangement), and then, contact **NTN** Engineering for technical assistance.

Data 1

In the high speed region of $10\,000\text{ min}^{-1}$, the noise level is 6 to 8 dBA lower (see Fig. 9.30).

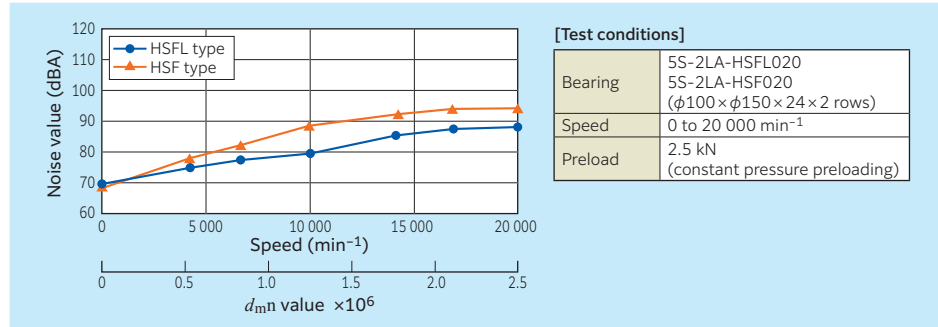

Fig. 9.30 Comparison of noise levels

Data 2

For 5S-HSFL type bearings, the temperature of the outer rings remains stable even with an air consumption as low as 10 NL/min (50 to 25 % of the recommended air consumption for standard bearings) at a speed of $21\,000\text{ min}^{-1}$ (d_{mn} value 2.6×10^6) (see Fig. 9.31).

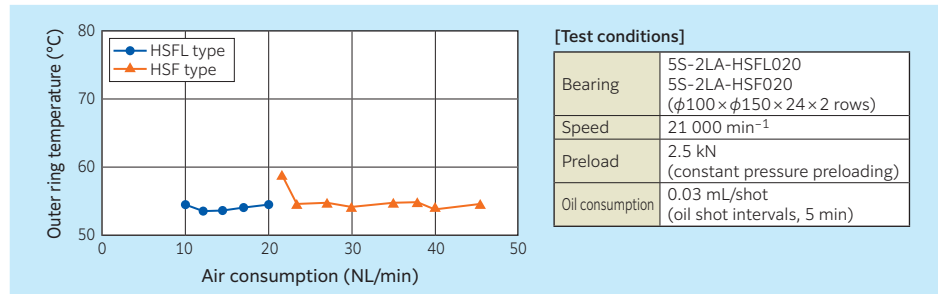

Fig. 9.31 Relationship between air consumption and temperature rise

Data 3

The 5S-HSFL type bearings can operate at $21\,000\text{ min}^{-1}$ (d_{mn} value 2.6×10^6) with oil shot intervals of 21 min (reduction of 20 to 90 % as compared with the recommended oil consumption for standard bearings) (see Fig. 9.32).

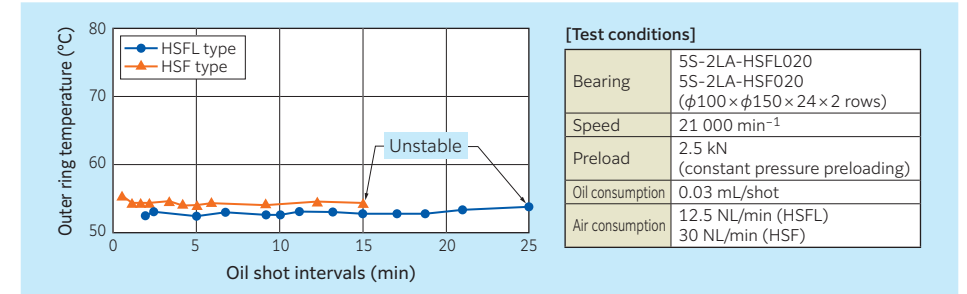

Fig. 9.32 Relationship between oil shot intervals and temperature rise

Data 4

5S-HSL type bearings can reliably run at a speed of $19\,000\text{ min}^{-1}$ (d_{mn} value 2.38×10^6) (fixed position preloading) (see Fig. 9.33) with both decrease air and oil consumption.

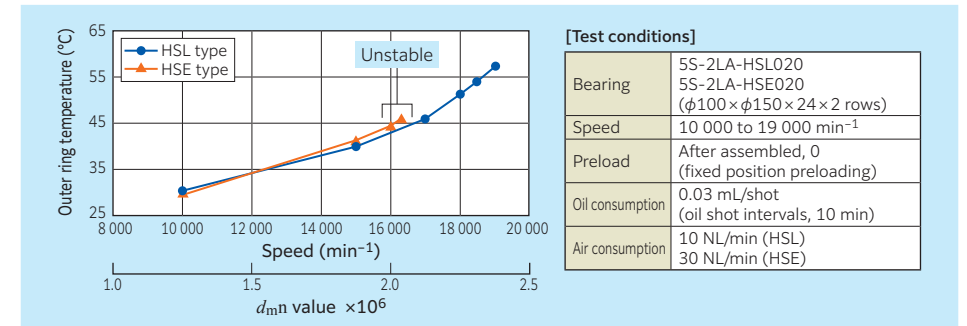

Fig. 9.33 High speed test results (fixed position preloading)

9.17 **ULTAGE** Air-oil lubricated high speed angular contact ball bearings with re-lubricating hole on the outer ring, HSEW type

HSEW type is an air-oil lubricated high speed angular contact ball bearing equipped with re-lubricating holes on the outer ring of the HSE type. Because there is no requirement for providing a nozzle hole on the spacer, the spacer width can be kept short, contributing to the more compact main spindle and improvement of spindle rigidity due to the placement of the bearings on the tool tip side.

In addition, lubrication reliability is increased due to the direct lubrication from the outer ring, enabling the reduction of air consumption and the supplied oil amount.

Bearing specification

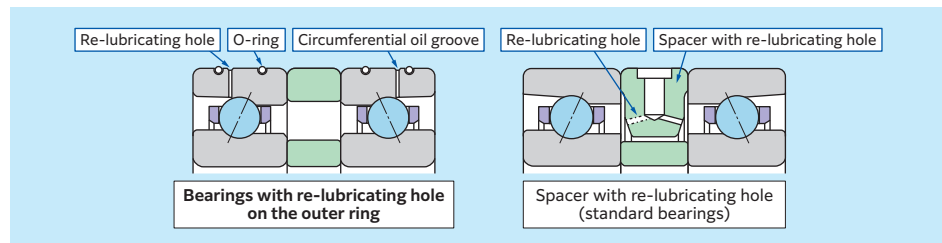
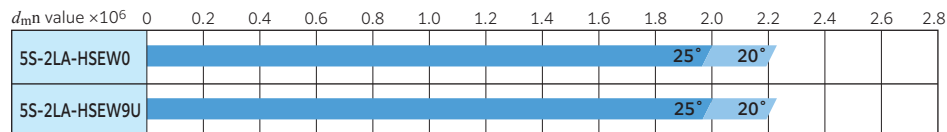

Fig. 9.34 HSEW type

Features

1. Compact main spindle design is possible due to the shorter spacer
2. Higher re-lubricating efficiency by the direct lubrication from the outer ring
3. Reduced noise level due to the air reduction effect

Permissible speed range



Notes) Permissible speed of each bearing (d_{mn} value) varies depending on the specifications of the machine on which the bearing is used (motor drive system, cooling system, and construction around the bearing). Consider the optimal choice referring to the above guideline (for two-row arrangement), and then, contact **NTN** Engineering for technical assistance.

About chamfering of re-lubricating hole on the housing

Ensure to provide chamfering on the re-lubricating hole of the housing to avoid damage of outer O-ring when the HSEW type is inserted into the housing (see Fig. 9.35).

We recommend that chamfering is only applied to the hole.

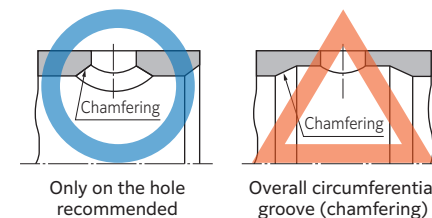

Fig. 9.35 Chamfering of re-lubricating hole on the housing

About phases of re-lubricating hole on the housing and re-lubricating hole on the outer ring

For producing the air reduction effect, be sure to stagger the position of re-lubricating hole on the housing and re-lubricating hole on the outer ring.

Data 1

For the HSEW type bearings, the temperature of the outer rings remains stable even with an air consumption as low as 20 NL/min (1/2 of the recommended air consumption for standard bearings) at a speed of 18 000 min⁻¹ (d_{mn} value 2.25×10^6) (see Fig. 9.36).

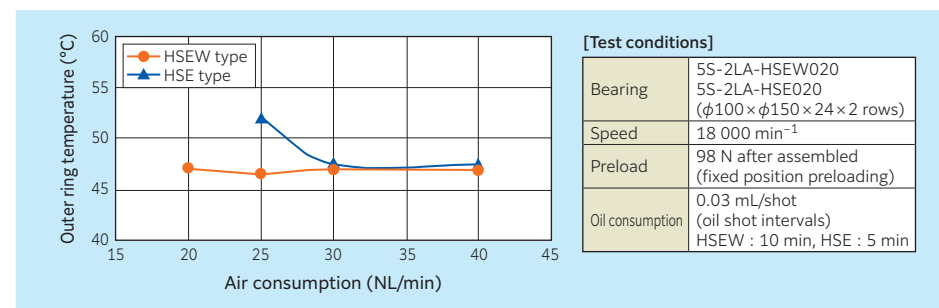

Fig. 9.36 Relationship between air consumption and temperature rise

Data 2

The HSEW type bearings can operate at $18\,000\text{ min}^{-1}$ ($d_{m,n}$ value 2.25×10^6) with an oil shot interval of 20 min (1/4 of the recommended oil consumption for standard bearings) (see Fig. 9.37).

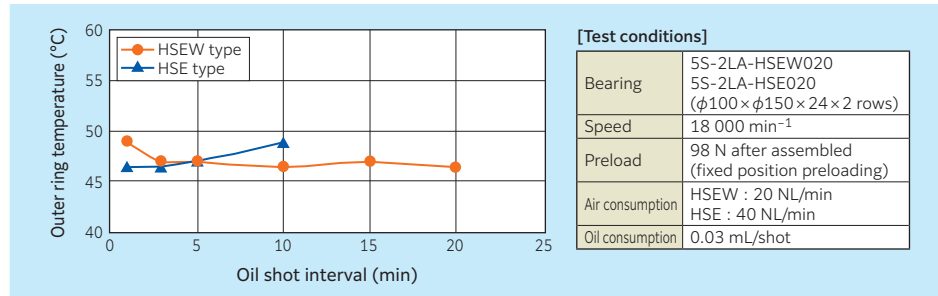

Fig. 9.37 Relationship between oil shot interval and temperature rise

Data 3

The HSEW type has achieved reduced noise level compared with the HSE type (see Fig. 9.38).

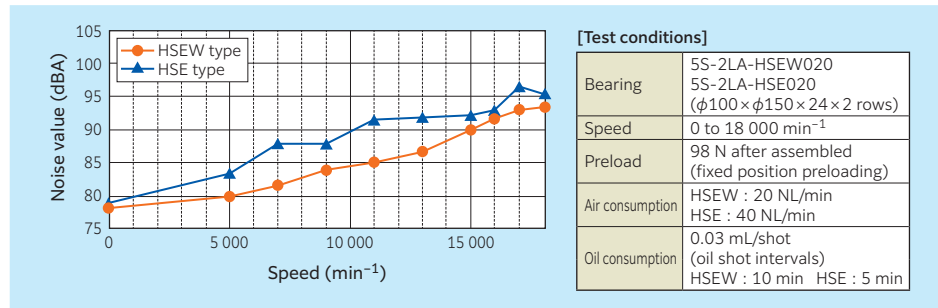

Fig. 9.38 Comparison of noise levels

9.18 ULTAGE Grease-lubricated sealed standard angular contact ball bearings 79LLB and 70LLB types

The 79LLB and 70LLB types are grease-lubricated, eco-friendly bearings that can achieve stable high speed operation with limited temperature rise.

They can allow, longer service life and preservation of healthy working environment for rotating tools with shaft diameters less than 50 mm.

Bearing specification

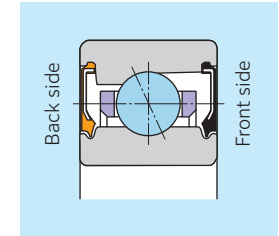

Fig. 9.39 79LLB and 70LLB types

Features

1. Internal design is optimized for high speed operation and limited temperature rise.
 2. Longer grease life due to adoption of special grease and non-contact seals for grease retention.
 3. Contact angles of 15° and 25° are available.
 4. The standard types meet special precision P42 requirements (dimensional precision JIS Class 4 and running accuracy JIS Class 2).
 5. Seals of different colors are used for front (black) and back (orange) sides.
- Bearing configuration can be easily identified by color.
6. Available with either steel or ceramic balls.

Simplified main spindle configuration

Due to the optimized internal structure, the 79LLB and 70LLB types can reliably run at a higher speed with grease lubrication. The grease lubricating system is virtually free from oil mist emission, and contributes to a simpler main spindle structure, reduction in environmental impact and decrease in cost (see Fig. 9.40).

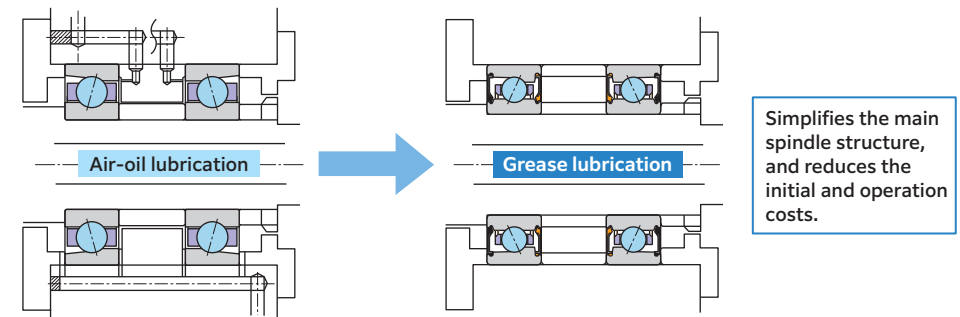
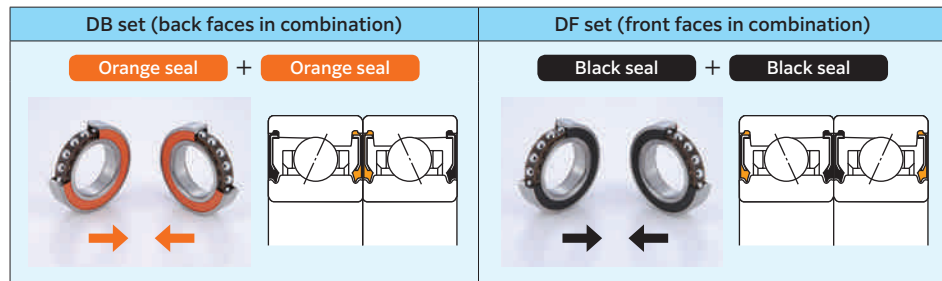

Fig. 9.40 Modification of lubrication system (air-oil lubrication to grease lubrication)

Easier handling with 79LLB and 70LLB types

The 79LLB and 70LLB types are prefilled with grease. They can be readily used after only wiping away rust preventive oil. Seals of different colors are used for the front and back sides of the bearing. Black seals are used for the front sides and orange seals are used for the back sides, so configurations are readily identified by colors (see Table 9.26).

Table 9.26 Bearing Combinations and Seal Colors



Permissible speed range

$d_m n$ value $\times 10^6$	0	0.2	0.4	0.6	0.8	1.0	1.2	1.4	
70 LLB	25°					15°			
79 LLB	25°					15°			
5S-70 LLB	25°					15°			
5S-79 LLB	25°					15°			

Notes) Permissible speed of each bearing ($d_m n$ value) varies depending on the specifications of the machine on which the bearing is used (motor drive system, cooling system, and construction around the bearing). Consider the optimal choice referring to the above guideline (for two-row arrangement), and then, contact NTN Engineering for technical assistance.

Data

Optimization of the internal design promotes stable operation of $d_m n$ value 1.1×10^6 (see Fig. 9.41 and Fig. 9.42).

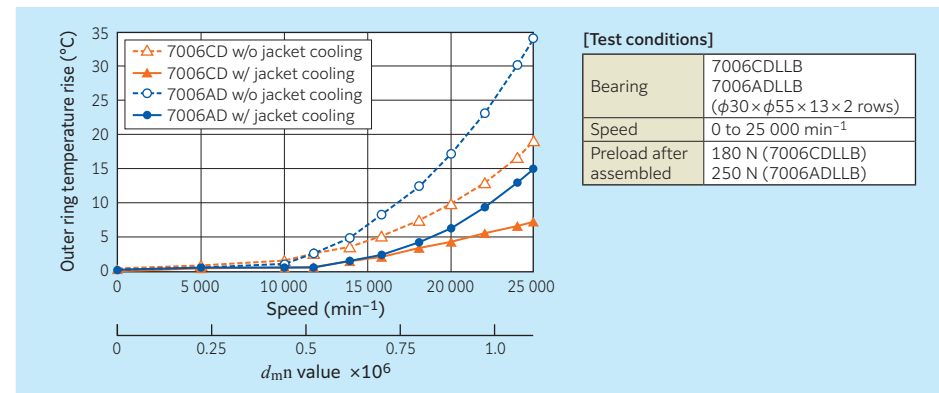

Fig. 9.41 High speed test results (Steel ball specification, contact angles 15°, 25°)

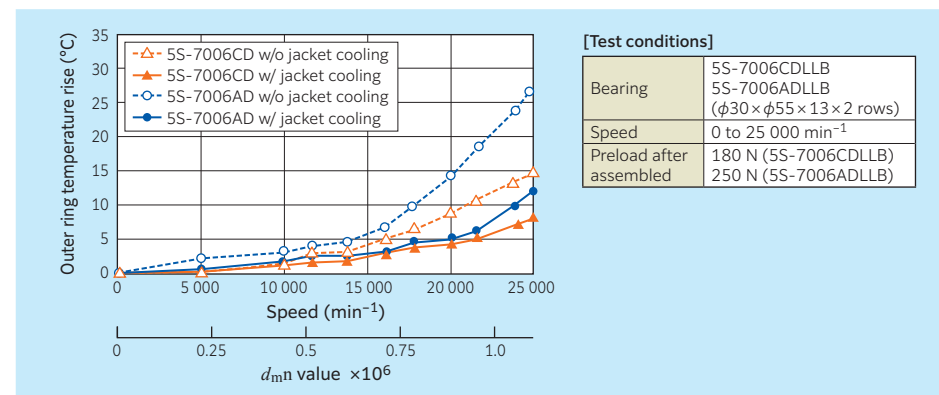

Fig. 9.42 High speed test results (Ceramic ball specification, contact angles 15°, 25°)

9.19 **ULTAGE** Grease-lubricated sealed high speed angular contact ball bearings BNS LLB type

By the optimized material and internal structure, BNS LLB type bearings have excellent performance at higher speeds. This helps to reduce pollution and cost.

■ Features

1. Adoption of special materials and unique internal design improve anti-seizure properties (15 times better than the conventional type) and wear resistance (1/6 reduction compared the conventional type).
2. Optimized internal design enables high speed operation and high rigidity.
3. Available with either steel or ceramic balls.
4. Adoption of grease pockets, special grease, and non-contact seals improves service life.

■ Bearing specification

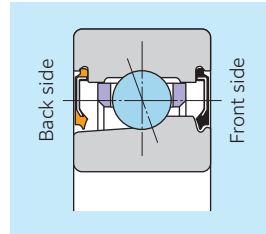

Fig. 9.43 BNS LLB type

■ Simplified main spindle configuration

BNS LLB type bearings can reliably operate at a higher speed with grease lubrication. The grease lubrication system is virtually free from oil mist emission can simplify the main spindle structure, reduce pollution and decrease cost (see Fig. 9.44).

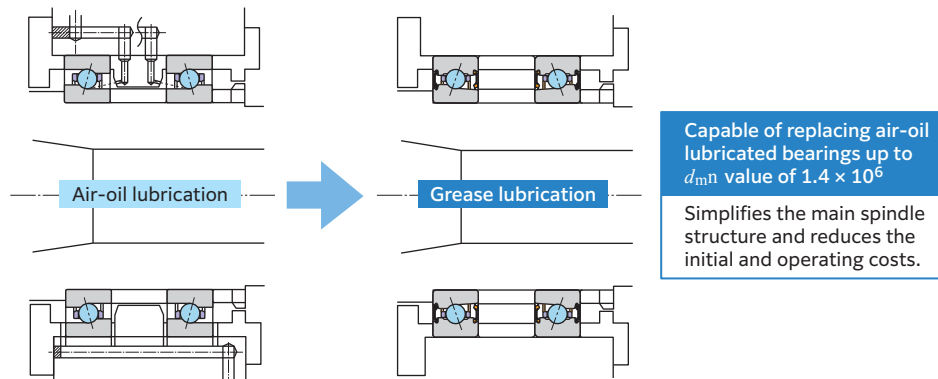

Fig. 9.44 Modification of lubrication system (air-oil lubrication to grease lubrication)

■ Easier handling with BNS LLB type

The BNS LLB type has been packed with grease in advance. They can be used after wiping away rust preventive oil. Seals in different colors are used for the front and back sides of the bearings. Black seals are used for the front sides and orange seals are used for the back sides, so configurations can be easily identified by color (see Table 9.27).

Table 9.27 Bearing Combinations and Seal Colors

DB set (back faces in combination)		DF set (front faces in combination)	
Orange seal	+ Orange seal	Black seal	+ Black seal

■ Permissible speed range

d_{mn} value $\times 10^6$	0	0.2	0.4	0.6	0.8	1.0	1.2	1.4	1.6	1.8	2.0	2.2	2.4	2.6	2.8
2LA-BNS0 LLB						25°, 15°, 20°									
2LA-BNS9 LLB						25°, 15°, 20°									
5S-2LA-BNS0 LLB						25°, 15°, 20°									
5S-2LA-BNS9 LLB						25°, 15°, 20°									

Notes) Permissible speed of each bearing (d_{mn} value) varies depending on the specifications of the machine on which the bearing is used (motor drive system, cooling system, and construction around the bearing). Consider the optimal choice referring to the above guideline (for two-row arrangement), and then, contact NTN Engineering for technical assistance.

■ Data 1

5S-2LA-BNS LLB type bearings exhibit stable temperature rise up to a $d_{m,n}$ value of 1.4×10^6 (see Fig. 9.45).

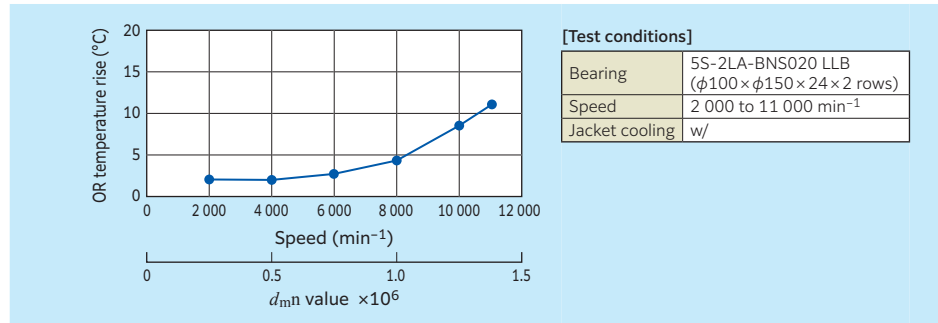

Fig. 9.45 High speed test results

■ Data 2

As a result of optimized design (such as grease reservoir) and special grease, 5S-2LA-BNS LLB type bearing have successfully achieved continuous operation in excess of 20 000 hours at a $d_{m,n}$ value of 1.4×10^6 (see Fig. 9.46).

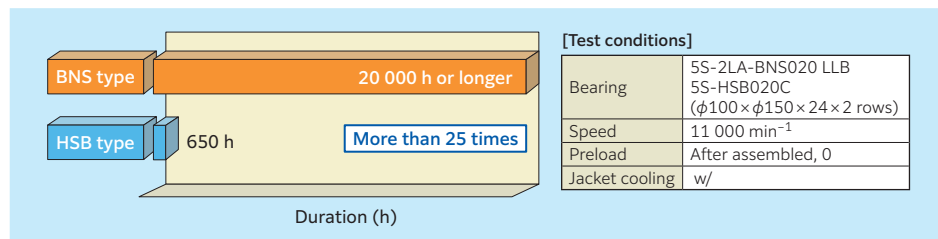

Fig. 9.46 Durability test results

Angular Contact Ball Bearings for Radial Loads

Dimension Tables



Standard angular contact ball bearings (steel ball spec.) 78 type

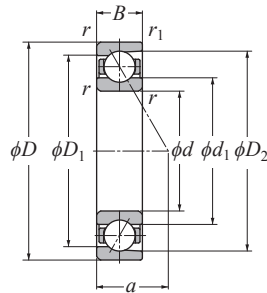

Contact angle 15° d 25–170 mm

Part number	Boundary dimensions					Basic load ratings				Allowable axial load		Factor f_0	Allowable speed		Load center mm a	Internal free space cm^3	Mass kg	Reference dimensions			Abutment and fillet dimensions					Part number
	mm					dynamic kN	static kgf	dynamic kN	static kgf	(static) kN	kgf		grease lubrication min^{-1}	oil lubrication min^{-1}				mm			mm					
	d	D	B	$r_{s min^1}$	$r_{1s min^1}$	C_r	C_{0r}	C_r	C_{0r}									d_1	D_1	D_2	d_a min	D_a max	D_b max	r_{as} max	r_{1as} max	
7805C	25	37	7	0.3	0.15	5.60	3.85	570	390	1.04	106	16.2	27 100	36 100	7.7	0.8	0.021	28.6	33.2	34.6	27.5	34.5	35.8	0.3	0.15	7805C
7806C	30	42	7	0.3	0.15	5.95	4.50	605	460	1.20	122	16.5	23 300	31 100	8.3	1.1	0.025	33.6	38.4	39.6	32.5	39.5	40.8	0.3	0.15	7806C
7807C	35	47	7	0.3	0.15	6.40	5.25	655	535	1.41	144	16.4	20 500	27 300	9.0	1.3	0.028	38.6	43.4	44.6	37.5	44.5	45.8	0.3	0.15	7807C
7808C	40	52	7	0.3	0.15	6.70	5.75	685	585	1.57	160	16.2	18 300	24 300	9.7	1.4	0.031	43.6	48.4	49.6	42.5	49.5	50.8	0.3	0.15	7808C
7809C	45	58	7	0.3	0.15	6.95	6.25	705	640	1.73	176	16.0	16 300	21 700	10.4	1.6	0.039	49.1	53.9	55.1	47.5	55.5	56.8	0.3	0.15	7809C
7810C	50	65	7	0.3	0.15	8.70	8.05	890	820	2.31	236	16.1	14 600	19 500	11.2	1.8	0.049	54.8	60.2	61.6	52.5	62.5	63.8	0.3	0.15	7810C
7811C	55	72	9	0.3	0.15	14.5	12.7	1 470	1 300	5.55	565	16.4	13 200	17 600	13.0	3.2	0.079	60.1	66.9	69.2	57.5	69.5	70.8	0.3	0.15	7811C
7812C	60	78	10	0.3	0.15	14.9	13.6	1 520	1 390	6.00	610	16.3	12 200	16 200	14.3	3.9	0.10	65.6	72.4	74.7	62.5	75.5	76.8	0.3	0.15	7812C
7813C	65	85	10	0.6	0.3	15.6	14.9	1 590	1 520	5.30	540	16.2	11 200	14 900	15.1	4.4	0.12	71.4	78.6	80.7	69.5	80.5	82.5	0.6	0.3	7813C
7814C	70	90	10	0.6	0.3	16.0	15.8	1 630	1 610	7.10	720	16.1	10 500	14 000	15.7	5.1	0.13	76.6	83.4	85.7	74.5	85.5	87.5	0.6	0.3	7814C
7815C	75	95	10	0.6	0.3	16.4	16.7	1 670	1 700	6.00	615	16.0	9 900	13 200	16.4	5.0	0.14	81.4	88.6	90.7	79.5	90.5	92.5	0.6	0.3	7815C
7816C	80	100	10	0.6	0.3	16.8	17.6	1 710	1 790	7.95	810	15.9	9 300	12 400	17.1	5.7	0.15	86.6	93.4	95.7	84.5	95.5	97.5	0.6	0.3	7816C
7817C	85	110	13	1	0.6	24.5	24.7	2 500	2 520	10.7	1 090	16.1	8 600	11 500	19.6	9.8	0.26	93.1	101.9	104.9	90.5	104.5	105.5	1	0.6	7817C
7818C	90	115	13	1	0.6	25.2	26.1	2 570	2 670	10.5	1 070	16.1	8 200	10 900	20.3	11	0.27	98.0	107.0	109.8	95.5	109.5	110.5	1	0.6	7818C
7819C	95	120	13	1	0.6	25.9	27.6	2 640	2 820	12.1	1 240	16.0	7 800	10 400	20.9	11	0.28	103.1	111.9	114.8	100.5	114.5	115.5	1	0.6	7819C
7820C	100	125	13	1	0.6	26.1	28.3	2 660	2 890	12.5	1 270	16.0	7 500	10 000	21.6	12	0.30	108.1	116.9	119.8	105.5	119.5	120.5	1	0.6	7820C
7821C	105	130	13	1	0.6	26.7	29.8	2 720	3 050	13.2	1 340	15.9	7 100	9 500	22.3	13	0.31	113.1	122.0	124.8	110.5	124.5	125.5	1	0.6	7821C
7822C	110	140	16	1	0.6	38.5	42.5	3 900	4 350	21.0	2 140	16.1	6 700	9 000	24.8	19	0.49	119.8	130.2	134.0	115.5	134.5	135.5	1	0.6	7822C
7824C	120	150	16	1	0.6	39.0	44.5	3 950	4 550	22.1	2 260	16.0	6 200	8 300	26.1	20	0.52	129.8	140.2	144.0	125.5	144.5	145.5	1	0.6	7824C
7826C	130	165	18	1.1	0.6	52.0	59.5	5 300	6 050	28.4	2 900	16.1	5 700	7 600	28.8	28	0.91	141.3	153.7	158.1	137	158	160.5	1	0.6	7826C
7828C	140	175	18	1.1	0.6	53.0	62.5	5 400	6 350	30.0	3 050	16.0	5 300	7 100	30.1	30	0.97	151.3	163.7	168.1	147	168	170.5	1	0.6	7828C
7830C	150	190	20	1.1	0.6	67.0	79.5	6 850	8 100	48.5	4 950	16.1	4 900	6 600	32.8	45	1.33	163.4	177.1	182.2	157	183	185.5	1	0.6	7830C
7832C	160	200	20	1.1	0.6	68.5	83.5	7 000	8 500	41.0	4 200	16.0	4 700	6 200	34.2	46	1.41	172.9	187.1	192.2	167	193	195.5	1	0.6	7832C
7834C	170	215	22	1.1	0.6	84.0	102	8 550	10 400	49.0	4 950	16.1	4 400	5 800	36.8	53	1.87	184.4	200.6	206.3	177	208	210.5	1	0.6	7834C

1) Minimum allowable value for corner radius dimension r or r_1 .

Angular Contact Ball Bearings for Radial Loads

Dimension Tables



Dynamic equivalent radial load $P_r = X F_r + Y F_a$

$i f_0 F_a$	C_{0r}	e	Single row / Tandem				Back-to-back / Face-to-face			
			$F_a/F_r \leq e$		$F_a/F_r > e$		$F_a/F_r \leq e$		$F_a/F_r > e$	
			X	Y	X	Y	X	Y	X	Y
0.178	0.38				1.47		1.65		2.39	
0.357	0.4			1.4		1.57		2.28		
0.714	0.43			1.3		1.46		2.11		
1.07	0.46			1.23		1.38		2		
1.43	0.47			1.19	1	1.34	0.72	1.93		
2.14	0.5	1	0	1.12		1.26		1.82		
3.57	0.55			1.02		1.14		1.66		
5.35	0.56			1		1.12		1.63		
7.14	0.56			1		1.12		1.63		

Static equivalent radial load $P_{0r} = X_0 F_r + Y_0 F_a$

Single row / Tandem		Back-to-back / Face-to-face	
X_0	Y_0	X_0	Y_0
0.5	0.46	1	0.92

When $P_{0r} < F_r$ with single-row or tandem arrangement, $P_{0r} = F_r$.

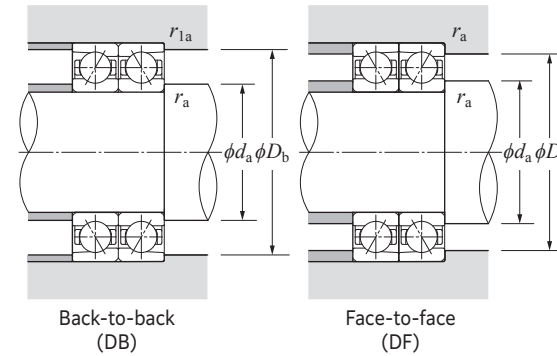

Angular Contact Ball Bearings for Radial Loads

ULTAGE Standard angular contact ball bearings (steel ball spec.)
79U type

Dimension Tables

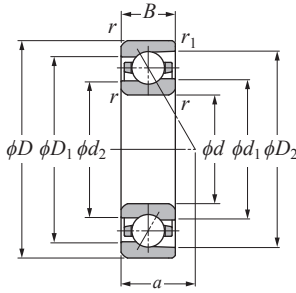

Contact angle 25° d 10–130 mm

Part number	Boundary dimensions					Basic load ratings				Allowable axial load		Allowable speed		Load center mm a	Internal free space cm ³ Single-row (approx.) Single-row (approx.)	Mass kg	Reference dimensions				Abutment and fillet dimensions					Part number
	mm					dynamic	static	dynamic	static	kN	kgf	grease	oil				mm				mm					
	d	D	B	$r_s \min^{1)}$	$r_{1s} \min^{1)}$	C_r	C_{Or}	C_r	C_{Or}	(static)		lubrication	lubrication				d_1	d_2	D_1	D_2	d_a min	D_a max	D_b max	r_{as} max	r_{1as} max	
7900UAD	10	22	6	0.3	0.15	3.40	1.58	345	161	1.77	180	63 400	102 500	6.8	0.4	0.01	14.3	13.5	17.7	19.4	12.5	19.5	20.8	0.3	0.15	7900UAD
7901UAD	12	24	6	0.3	0.15	3.55	1.77	360	181	1.92	196	56 400	91 100	7.2	0.4	0.01	16.3	15.5	19.7	21.3	14.5	21.5	22.8	0.3	0.15	7901UAD
7902UAD	15	28	7	0.3	0.15	5.40	2.77	550	283	2.81	287	47 200	76 300	8.6	0.8	0.02	19.3	18.3	23.7	25.6	17.5	25.5	26.8	0.3	0.15	7902UAD
7903UAD	17	30	7	0.3	0.15	5.60	3.05	575	310	3.00	310	43 200	69 800	9.0	0.8	0.02	21.3	20.3	25.7	27.7	19.5	27.5	28.8	0.3	0.15	7903UAD
7904UAD	20	37	9	0.3	0.15	8.05	4.65	820	475	4.70	480	35 600	57 500	11.2	1.5	0.04	25.9	24.7	31.1	33.6	22.5	34.5	35.8	0.3	0.15	7904UAD
7905UAD	25	42	9	0.3	0.15	8.60	5.50	875	560	5.35	545	30 300	49 000	12.4	1.8	0.04	30.9	29.7	36.1	38.6	27.5	39.5	40.8	0.3	0.15	7905UAD
7906UAD	30	47	9	0.3	0.15	9.00	6.30	920	640	6.00	610	26 400	42 600	13.5	2.0	0.05	35.9	34.7	41.1	43.6	32.5	44.5	45.8	0.3	0.15	7906UAD
7907UAD	35	55	10	0.6	0.3	14.4	9.75	1 470	995	10.1	1 030	22 600	36 400	15.6	3.4	0.07	41.6	39.9	48.4	51.7	39.5	50.5	52.5	0.6	0.3	7907UAD
7908UAD	40	62	12	0.6	0.3	15.2	11.2	1 550	1 140	11.3	1 160	19 900	32 200	18.0	4.7	0.11	47.6	45.9	54.4	57.8	44.5	57.5	59.5	0.6	0.3	7908UAD
7909UAD	45	68	12	0.6	0.3	18.8	14.1	1 920	1 440	14.6	1 490	18 000	29 000	19.2	5.9	0.12	52.7	50.8	60.4	64.0	49.5	63.5	65.5	0.6	0.3	7909UAD
7910UAD	50	72	12	0.6	0.3	19.8	15.8	2 020	1 610	16.2	1 650	16 600	26 900	20.3	6.2	0.13	57.2	55.3	64.9	68.5	54.5	67.5	69.5	0.6	0.3	7910UAD
7911UAD	55	80	13	1	0.6	20.6	17.5	2 100	1 790	17.7	1 800	15 000	24 300	22.3	7.5	0.18	63.7	61.8	71.4	75.1	60.5	74.5	75.5	1	0.6	7911UAD
7912UAD	60	85	13	1	0.6	21.4	19.1	2 190	1 950	19.2	1 960	14 000	22 600	23.5	8.0	0.19	68.7	66.8	76.4	80.1	65.5	79.5	80.5	1	0.6	7912UAD
7913UAD	65	90	13	1	0.6	21.7	19.7	2 210	2 010	19.9	2 030	13 100	21 200	24.6	8.6	0.21	73.7	71.8	81.4	85.0	70.5	84.5	85.5	1	0.6	7913UAD
7914UAD	70	100	16	1	0.6	31.0	28.6	3 150	2 920	27.9	2 840	11 900	19 300	27.9	14	0.34	80.3	78.0	89.7	94.3	75.5	94.5	95.5	1	0.6	7914UAD
7915UAD	75	105	16	1	0.6	31.5	29.6	3 200	3 000	29.0	2 960	11 300	18 200	29.1	15	0.36	85.3	83.0	94.7	99.2	80.5	99.5	100.5	1	0.6	7915UAD
7916UAD	80	110	16	1	0.6	32.0	30.5	3 250	3 100	30.0	3 050	10 600	17 200	30.4	16	0.38	90.8	88.5	100.2	104.7	85.5	104.5	105.5	1	0.6	7916UAD
7917UAD	85	120	18	1.1	0.6	43.0	41.5	4 350	4 250	39.5	4 000	9 900	16 000	33.0	22	0.54	96.9	94.3	108.1	113.4	92	113	115.5	1	0.6	7917UAD
7918UAD	90	125	18	1.1	0.6	43.5	43.0	4 450	4 400	41.0	4 200	9 400	15 300	34.2	23	0.56	101.9	99.3	113.1	118.4	97	118	120.5	1	0.6	7918UAD
7919UAD	95	130	18	1.1	0.6	44.0	44.5	4 500	4 500	42.5	4 350	9 000	14 600	35.3	24	0.59	106.9	104.3	118.1	123.4	102	123	125.5	1	0.6	7919UAD
7920UAD	100	140	20	1.1	0.6	56.5	57.5	5 800	5 850	56.0	5 750	8 500	13 700	38.1	33	0.81	113.6	110.5	126.4	132.5	107	133	135.5	1	0.6	7920UAD
7921UAD	105	145	20	1.1	0.6	57.5	59.0	5 850	6 050	58.5	5 950	8 100	13 100	39.3	34	0.84	118.6	115.5	131.4	137.5	112	138	140.5	1	0.6	7921UAD
7922UAD	110	150	20	1.1	0.6	58.5	61.0	5 950	6 250	60.5	6 150	7 800	12 600	40.4	36	0.87	123.6	120.5	136.4	142.5	117	143	145.5	1	0.6	7922UAD
7924UAD	120	165	22	1.1	0.6	72.0	76.0	7 350	7 750	73.5	7 500	7 100	11 500	44.4	48	1.19	135.2	131.7	149.8	156.7	127	158	160.5	1	0.6	7924UAD
7926UAD	130	180	24	1.5	1	88.5	95.0	9 050	9 700	94.0	9 550	6 600	10 600	48.3	63	1.57	146.9	143.0	163.2	170.8	138.5	171.5	174.5	1.5	1	7926UAD

1) Minimum allowable value for corner radius dimension r or r_1 .

Angular Contact Ball Bearings for Radial Loads

Dynamic equivalent radial load
 $P_r = X F_r + Y F_a$

Dimension Tables

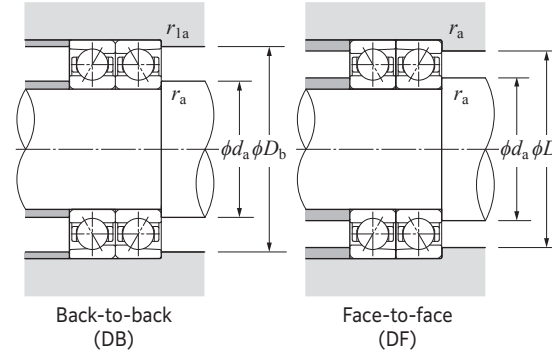

e	Single row / Tandem				Back-to-back / Face-to-face			
	$F_a/F_r \leq e$		$F_a/F_r > e$		$F_a/F_r \leq e$		$F_a/F_r > e$	
	X	Y	X	Y	X	Y	X	Y
0.68	1	0	0.41	0.87	1	0.92	0.67	1.41

Static equivalent radial load
 $P_{0r} = X_0 F_r + Y_0 F_a$

e	Single row / Tandem		Back-to-back / Face-to-face	
	X_0	Y_0	X_0	Y_0
	0.5	0.38	1	0.76

When $P_{0r} < F_r$ with single-row or tandem arrangement, $P_{0r} = F_r$.

Angular Contact Ball Bearings for Radial Loads

ULTAGE Standard angular contact ball bearings (steel ball spec.)
79U type

Dimension Tables

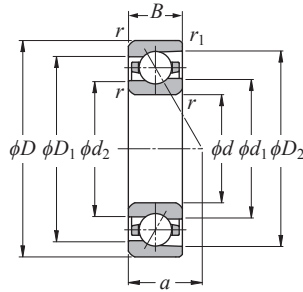

Contact angle 30° d 10–130 mm

Part number	Boundary dimensions					Basic load ratings				Allowable axial load		Allowable speed		Load center mm a	Internal free space cm ³ Single-row (approx.)	Mass kg Single-row (approx.)	Reference dimensions				Abutment and fillet dimensions					Part number
	mm					dynamic	static	dynamic	static	kN	kgf	grease lubrication	oil lubrication				mm				mm					
	d	D	B	$r_{s \min}^{1)}$	$r_{ls \min}^{1)}$	C_r	C_{Or}	C_r	C_{Or}	(static)								d_1	d_2	D_1	D_2	d_a min	D_a max	D_b max	r_{as} max	
7900U	10	22	6	0.3	0.15	3.25	1.53	335	156	1.36	139	53 700	73 200	7.7	0.4	0.01	14.3	13.5	17.7	19.3	12.5	19.5	20.8	0.3	0.15	7900U
7901U	12	24	6	0.3	0.15	3.40	1.71	350	175	1.48	151	47 700	65 000	8.2	0.4	0.01	16.3	15.5	19.7	21.3	14.5	21.5	22.8	0.3	0.15	7901U
7902U	15	28	7	0.3	0.15	5.20	2.68	530	274	2.14	218	40 000	54 500	9.8	0.8	0.02	19.3	18.3	23.7	25.6	17.5	25.5	26.8	0.3	0.15	7902U
7903U	17	30	7	0.3	0.15	5.40	2.95	555	300	2.29	234	36 600	49 800	10.3	0.8	0.02	21.3	20.3	25.7	27.7	19.5	27.5	28.8	0.3	0.15	7903U
7904U	20	37	9	0.3	0.15	7.75	4.50	790	460	3.60	365	30 100	41 100	12.8	1.5	0.04	25.9	24.7	31.1	33.5	22.5	34.5	35.8	0.3	0.15	7904U
7905U	25	42	9	0.3	0.15	8.25	5.30	840	540	4.10	415	25 600	35 000	14.2	1.8	0.04	30.9	29.7	36.1	38.5	27.5	39.5	40.8	0.3	0.15	7905U
7906U	30	47	9	0.3	0.15	8.65	6.05	885	615	4.60	465	22 300	30 400	15.7	2.0	0.05	35.9	34.7	41.1	43.5	32.5	44.5	45.8	0.3	0.15	7906U
7907U	35	55	10	0.6	0.3	13.8	9.40	1 410	960	7.85	800	19 100	26 000	18.1	3.4	0.07	41.6	39.9	48.4	51.6	39.5	50.5	52.5	0.6	0.3	7907U
7908U	40	62	12	0.6	0.3	14.6	10.7	1 490	1 100	8.75	895	16 900	23 000	20.8	4.7	0.11	47.6	45.9	54.4	57.7	44.5	57.5	59.5	0.6	0.3	7908U
7909U	45	68	12	0.6	0.3	18.1	13.6	1 840	1 380	11.4	1 160	15 200	20 700	22.4	5.9	0.12	52.7	50.8	60.4	64.0	49.5	63.5	65.5	0.6	0.3	7909U
7910U	50	72	12	0.6	0.3	19.0	15.2	1 940	1 550	12.6	1 280	14 100	19 200	23.7	6.2	0.13	57.2	55.3	64.9	68.5	54.5	67.5	69.5	0.6	0.3	7910U
7911U	55	80	13	1	0.6	19.8	16.8	2 020	1 720	13.8	1 410	12 700	17 400	26.1	7.5	0.18	63.7	61.8	71.4	75.0	60.5	74.5	75.5	1	0.6	7911U
7912U	60	85	13	1	0.6	20.6	18.2	2 100	1 850	15.0	1 530	11 900	16 200	27.5	8.0	0.19	68.7	66.8	76.4	80.1	65.5	79.5	80.5	1	0.6	7912U
7913U	65	90	13	1	0.6	20.8	18.8	2 120	1 910	15.6	1 590	11 100	15 100	29.0	8.6	0.21	73.7	71.8	81.4	85.0	70.5	84.5	85.5	1	0.6	7913U
7914U	70	100	16	1	0.6	29.8	27.3	3 050	2 780	21.5	2 190	10 100	13 800	32.6	14	0.34	80.3	78.0	89.7	94.2	75.5	94.5	95.5	1	0.6	7914U
7915U	75	105	16	1	0.6	30.0	28.2	3 100	2 870	22.3	2 280	9 600	13 000	34.1	15	0.36	85.3	83.0	94.7	99.2	80.5	99.5	100.5	1	0.6	7915U
7916U	80	110	16	1	0.6	30.5	29.1	3 100	2 970	23.2	2 370	9 000	12 300	35.7	16	0.38	90.8	88.5	100.2	104.7	85.5	104.5	105.5	1	0.6	7916U
7917U	85	120	18	1.1	0.6	41.0	39.5	4 200	4 050	30.5	3 100	8 400	11 400	38.7	22	0.54	96.9	94.3	108.1	113.4	92	113	115.5	1	0.6	7917U
7918U	90	125	18	1.1	0.6	41.5	41.0	4 250	4 150	31.5	3 200	8 000	10 900	40.2	23	0.56	101.9	99.3	113.1	118.3	97	118	120.5	1	0.6	7918U
7919U	95	130	18	1.1	0.6	42.5	42.0	4 300	4 300	32.5	3 350	7 600	10 400	41.6	24	0.59	106.9	104.3	118.1	123.3	102	123	125.5	1	0.6	7919U
7920U	100	140	20	1.1	0.6	54.5	54.5	5 550	5 550	43.5	4 450	7 200	9 800	44.8	33	0.81	113.6	110.5	126.4	132.5	107	133	135.5	1	0.6	7920U
7921U	105	145	20	1.1	0.6	55.0	56.5	5 650	5 750	45.0	4 600	6 900	9 400	46.2	34	0.84	118.6	115.5	131.4	137.5	112	138	140.5	1	0.6	7921U
7922U	110	150	20	1.1	0.6	56.0	58.0	5 700	5 900	46.5	4 750	6 600	9 000	47.7	36	0.87	123.6	120.5	136.4	142.5	117	143	145.5	1	0.6	7922U
7924U	120	165	22	1.1	0.6	69.0	72.5	7 050	7 350	56.5	5 750	6 000	8 200	52.3	48	1.19	135.2	131.7	149.8	156.6	127	158	160.5	1	0.6	7924U
7926U	130	180	24	1.5	1	85.0	90.5	8 650	9 250	72.5	7 400	5 500	7 600	56.9	63	1.57	146.9	143.0	163.2	170.8	138.5	171.5	174.5	1.5	1	7926U

1) Minimum allowable value for corner radius dimension r or r_1 .

Angular Contact Ball Bearings for Radial Loads

ULTAGE Standard angular contact ball bearings (steel ball spec.)
79U type

Dimension Tables

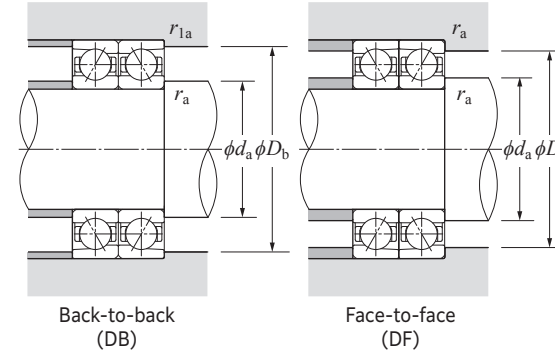

Dynamic equivalent radial load
 $P_r = X F_r + Y F_a$

e	Single row / Tandem				Back-to-back / Face-to-face			
	$F_a/F_r \leq e$	$F_a/F_r > e$	$F_a/F_r \leq e$	$F_a/F_r > e$	$F_a/F_r \leq e$	$F_a/F_r > e$	$F_a/F_r \leq e$	$F_a/F_r > e$
0.8	X	Y	X	Y	X	Y	X	Y
	1	0	0.39	0.76	1	0.78	0.63	1.24

Static equivalent radial load
 $P_{0r} = X_0 F_r + Y_0 F_a$

e	Single row / Tandem		Back-to-back / Face-to-face	
	X_0	Y_0	X_0	Y_0
0.5	0.5	0.33	1	0.66

When $P_{0r} < F_r$ with single-row or tandem arrangement, $P_{0r} = F_r$.

Main Spindle Bearings

Main Spindle Bearings

Angular Contact Ball Bearings for Radial Loads

ULTAGE Standard angular contact ball bearings (steel ball spec.)
70U type

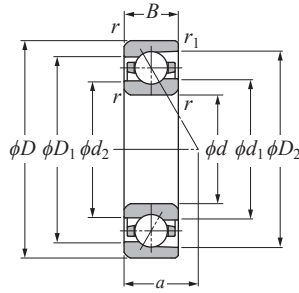

Contact angle 25° d 10–140 mm

Part number	Boundary dimensions					Basic load ratings				Allowable axial load		Allowable speed		Load center	Internal free space	Mass	Reference dimensions				Abutment and fillet dimensions					Part number
	mm					dynamic	static	dynamic	static	kN	kgf	grease lubrication	oil lubrication				mm				mm					
	d	D	B	$r_s \min^{-1}$	$r_{1s} \min^{-1}$	C_r	C_{0r}	C_r	C_{0r}	(static)	kgf						a	Single-row (approx.)	Single-row (approx.)	d_1	d_2	D_1	D_2	$d_a \min$	$D_a \max$	
7000UAD	10	26	8	0.3	0.15	5.70	2.40	580	244	2.77	283	57 000	92 100	8.2	0.9	0.019	15.2	14.0	20.4	22.7	12.5	23.5	24.8	0.3	0.15	7000UAD
7001UAD	12	28	8	0.3	0.15	6.20	2.82	630	287	3.10	315	49 500	80 000	8.8	1.0	0.021	17.9	16.7	23.1	25.4	14.5	25.5	26.8	0.3	0.15	7001UAD
7002UAD	15	32	9	0.3	0.15	7.00	3.55	715	360	3.75	380	43 200	69 800	10.0	1.3	0.030	20.9	19.7	26.1	28.5	17.5	29.5	30.8	0.3	0.15	7002UAD
7003UAD	17	35	10	0.3	0.15	8.75	4.35	890	445	4.85	495	39 000	63 100	11.1	1.8	0.037	23.0	21.6	29.0	32.0	19.5	32.5	33.8	0.3	0.15	7003UAD
7004UAD	20	42	12	0.6	0.3	11.8	6.30	1 200	645	7.10	720	32 200	52 100	13.4	2.9	0.067	28.1	26.4	34.9	38.3	24.5	37.5	39.5	0.6	0.3	7004UAD
7005UAD	25	47	12	0.6	0.3	13.0	7.65	1 320	780	8.30	845	28 200	45 600	14.5	3.3	0.079	32.6	30.9	39.4	42.8	29.5	42.5	44.5	0.6	0.3	7005UAD
7006UAD	30	55	13	1	0.6	16.7	10.5	1 700	1 070	11.5	1 170	23 600	38 100	16.6	4.8	0.11	39.2	37.3	46.9	50.6	35.5	49.5	50.5	1	0.6	7006UAD
7007UAD	35	62	14	1	0.6	21.0	13.9	2 140	1 420	14.3	1 460	20 900	33 800	18.4	6.3	0.15	44.2	42.2	52.8	56.9	40.5	56.5	57.5	1	0.6	7007UAD
7008UAD	40	68	15	1	0.6	22.5	16.0	2 290	1 630	16.1	1 650	18 800	30 400	20.2	7.4	0.19	49.7	47.7	58.3	62.5	45.5	62.5	63.5	1	0.6	7008UAD
7009UAD	45	75	16	1	0.6	26.6	19.4	2 710	1 980	19.9	2 030	16 900	27 300	22.1	9.4	0.24	55.3	53.0	64.7	69.3	50.5	69.5	70.5	1	0.6	7009UAD
7010UAD	50	80	16	1	0.6	28.2	21.9	2 880	2 230	22.2	2 260	15 600	25 200	23.2	11	0.26	60.3	58.0	69.7	74.3	55.5	74.5	75.5	1	0.6	7010UAD
7011UAD	55	90	18	1.1	0.6	37.0	28.7	3 800	2 930	28.6	2 920	14 000	22 600	26.0	16	0.38	66.9	64.3	78.1	83.5	62	83	85.5	1	0.6	7011UAD
7012UAD	60	95	18	1.1	0.6	38.0	30.5	3 900	3 150	30.0	3 100	13 100	21 200	27.2	17	0.41	71.9	69.3	83.1	88.4	67	88	90.5	1	0.6	7012UAD
7013UAD	65	100	18	1.1	0.6	40.0	34.0	4 100	3 500	33.5	3 400	12 300	19 900	28.3	18	0.44	76.9	74.3	88.1	93.4	72	93	95.5	1	0.6	7013UAD
7014UAD	70	110	20	1.1	0.6	51.0	43.0	5 200	4 350	43.5	4 450	11 300	18 200	31.1	24	0.61	83.6	80.5	96.4	102.6	77	103	105.5	1	0.6	7014UAD
7015UAD	75	115	20	1.1	0.6	52.0	45.5	5 300	4 650	45.5	4 650	10 700	17 300	32.3	26	0.64	88.6	85.5	101.4	107.6	82	108	110.5	1	0.6	7015UAD
7016UAD	80	125	22	1.1	0.6	63.5	55.0	6 500	5 600	55.0	5 600	9 900	16 000	35.0	34	0.86	95.2	91.7	109.8	116.8	87	118	120.5	1	0.6	7016UAD
7017UAD	85	130	22	1.1	0.6	65.0	58.5	6 650	5 950	57.5	5 850	9 400	15 300	36.2	36	0.90	100.2	96.7	114.8	121.7	92	123	125.5	1	0.6	7017UAD
7018UAD	90	140	24	1.5	1	77.5	69.0	7 900	7 050	70.0	7 150	8 800	14 300	39.0	47	1.17	106.9	103.0	123.2	130.9	98.5	131.5	134.5	1.5	1	7018UAD
7019UAD	95	145	24	1.5	1	79.5	73.0	8 100	7 400	73.5	7 500	8 500	13 700	40.1	49	1.22	111.9	108.0	128.2	135.9	103.5	136.5	139.5	1.5	1	7019UAD
7020UAD	100	150	24	1.5	1	81.0	76.5	8 300	7 800	77.0	7 850	8 100	13 100	41.3	51	1.27	116.9	113.0	133.2	140.9	108.5	141.5	144.5	1.5	1	7020UAD
7021UAD	105	160	26	2	1	95.0	89.0	9 700	9 050	88.0	9 000	7 700	12 400	44.1	70	1.58	123.5	119.2	141.5	150.1	115	150	154.5	2	1	7021UAD
7022UAD	110	170	28	2	1	109	101	11 200	10 300	103	10 500	7 300	11 700	46.8	83	1.98	130.2	125.4	149.9	159.2	120	160	164.5	2	1	7022UAD
7024UAD	120	180	28	2	1	111	107	11 400	10 900	108	11 000	6 800	10 900	49.2	90	2.11	140.2	135.4	159.9	169.2	130	170	174.5	2	1	7024UAD
7026UAD	130	200	33	2	1	140	136	14 200	13 900	137	14 000	6 200	9 900	55.2	131	3.25	153.9	148.5	176.2	186.8	140	190	194.5	2	1	7026UAD
7028UAD	140	210	33	2	1	142	144	14 500	14 700	141	14 400	5 800	9 300	57.5	144	3.38	164.0	158.7	186.3	196.8	150	200	204.5	2	1	7028UAD

1) Minimum allowable value for corner radius dimension r or r_1 .

Angular Contact Ball Bearings for Radial Loads

Dynamic equivalent radial load
 $P_r = X F_r + Y F_a$

e	Single row / Tandem				Back-to-back / Face-to-face			
	$F_a/F_r \leq e$		$F_a/F_r > e$		$F_a/F_r \leq e$		$F_a/F_r > e$	
	X	Y	X	Y	X	Y	X	Y
0.68	1	0	0.41	0.87	1	0.92	0.67	1.41

Static equivalent radial load
 $P_{0r} = X_0 F_r + Y_0 F_a$

e	Single row / Tandem		Back-to-back / Face-to-face	
	X_0	Y_0	X_0	Y_0
	0.5	0.38	1	0.76

When $P_{0r} < F_r$ with single-row or tandem arrangement, $P_{0r} = F_r$.

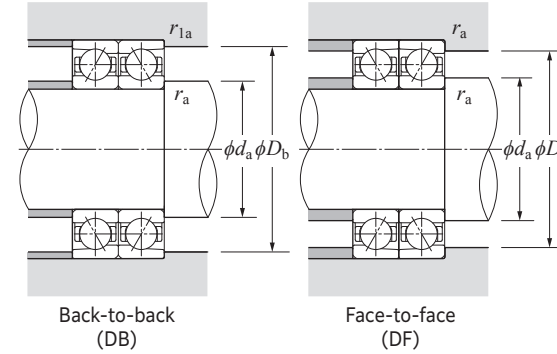

Back-to-back (DB)

Face-to-face (DF)

Angular Contact Ball Bearings for Radial Loads

ULTAGE Standard angular contact ball bearings (steel ball spec.)
70U type

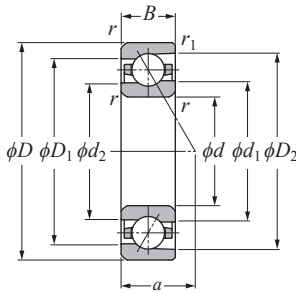

Contact angle 30° d 10–140 mm

Part number	Boundary dimensions					Basic load ratings				Allowable axial load		Allowable speed		Load center mm	Internal free space cm ³	Mass kg	Reference dimensions				Abutment and fillet dimensions					Part number
	mm					dynamic kN	static kN	dynamic kgf	static kgf	(static)		grease lubrication	oil lubrication				mm				mm					
	d	D	B	r_s min ¹⁾	r_{1s} min ¹⁾	C_T	C_{0r}	C_T	C_{0r}	(static)	(static)						d_1	d_2	D_1	D_2	d_a min	D_a max	D_b max	r_{as} max	r_{1as} max	
7000U	10	26	8	0.3	0.15	5.55	2.33	565	238	2.12	216	48 200	65 700	9.2	0.9	0.019	15.2	14.0	20.4	22.7	12.5	23.5	24.8	0.3	0.15	7000U
7001U	12	28	8	0.3	0.15	6.00	2.74	615	279	2.37	242	41 900	57 100	10.0	1.0	0.021	17.9	16.7	23.1	25.4	14.5	25.5	26.8	0.3	0.15	7001U
7002U	15	32	9	0.3	0.15	6.80	3.45	690	350	2.86	292	36 600	49 800	11.3	1.3	0.030	20.9	19.7	26.1	28.4	17.5	29.5	30.8	0.3	0.15	7002U
7003U	17	35	10	0.3	0.15	8.45	4.20	865	430	3.70	380	33 000	45 000	12.6	1.8	0.037	23.0	21.6	29.0	31.9	19.5	32.5	33.8	0.3	0.15	7003U
7004U	20	42	12	0.6	0.3	11.4	6.10	1 160	620	5.45	560	27 300	37 200	15.2	2.9	0.067	28.1	26.4	34.9	38.3	24.5	37.5	39.5	0.6	0.3	7004U
7005U	25	47	12	0.6	0.3	12.5	7.40	1 280	755	6.40	655	23 900	32 500	16.5	3.3	0.079	32.6	30.9	39.4	42.8	29.5	42.5	44.5	0.6	0.3	7005U
7006U	30	55	13	1	0.6	16.1	10.2	1 640	1 040	8.90	910	20 000	27 200	19.0	4.8	0.11	39.2	37.3	46.9	50.6	35.5	49.5	50.5	1	0.6	7006U
7007U	35	62	14	1	0.6	20.3	13.4	2 070	1 370	11.0	1 120	17 700	24 100	21.1	6.3	0.15	44.2	42.2	52.8	56.9	40.5	56.5	57.5	1	0.6	7007U
7008U	40	68	15	1	0.6	21.6	15.4	2 200	1 570	12.4	1 260	15 900	21 700	23.2	7.4	0.19	49.7	47.7	58.3	62.4	45.5	62.5	63.5	1	0.6	7008U
7009U	45	75	16	1	0.6	25.6	18.7	2 610	1 910	15.4	1 570	14 300	19 500	25.4	9.4	0.24	55.3	53.0	64.7	69.3	50.5	69.5	70.5	1	0.6	7009U
7010U	50	80	16	1	0.6	27.1	21.1	2 760	2 150	17.1	1 740	13 200	18 000	26.9	11	0.26	60.3	58.0	69.7	74.3	55.5	74.5	75.5	1	0.6	7010U
7011U	55	90	18	1.1	0.6	35.5	27.7	3 650	2 830	22.0	2 240	11 900	16 200	30.1	16	0.38	66.9	64.3	78.1	83.4	62	83	85.5	1	0.6	7011U
7012U	60	95	18	1.1	0.6	36.5	29.5	3 750	3 000	23.2	2 360	11 100	15 100	31.5	17	0.41	71.9	69.3	83.1	88.4	67	88	90.5	1	0.6	7012U
7013U	65	100	18	1.1	0.6	38.5	33.0	3 950	3 350	25.5	2 600	10 400	14 200	32.9	18	0.44	76.9	74.3	88.1	93.4	72	93	95.5	1	0.6	7013U
7014U	70	110	20	1.1	0.6	49.0	41.5	5 000	4 200	33.5	3 450	9 500	13 000	36.1	24	0.61	83.6	80.5	96.4	102.5	77	103	105.5	1	0.6	7014U
7015U	75	115	20	1.1	0.6	50.0	43.5	5 100	4 450	35.0	3 600	9 000	12 300	37.6	26	0.64	88.6	85.5	101.4	107.5	82	108	110.5	1	0.6	7015U
7016U	80	125	22	1.1	0.6	61.0	53.0	6 250	5 400	42.0	4 300	8 400	11 400	40.8	34	0.86	95.2	91.7	109.8	116.7	87	118	120.5	1	0.6	7016U
7017U	85	130	22	1.1	0.6	62.5	56.0	6 350	5 700	44.0	4 500	8 000	10 900	42.2	36	0.90	100.2	96.7	114.8	121.7	92	123	125.5	1	0.6	7017U
7018U	90	140	24	1.5	1	74.5	66.5	7 600	6 750	54.0	5 500	7 500	10 200	45.4	47	1.17	106.9	103.0	123.2	130.8	98.5	131.5	134.5	1.5	1	7018U
7019U	95	145	24	1.5	1	76.5	70.0	7 800	7 150	56.5	5 800	7 200	9 800	46.8	49	1.22	111.9	108.0	128.2	135.8	103.5	136.5	139.5	1.5	1	7019U
7020U	100	150	24	1.5	1	78.0	74.0	7 950	7 500	59.5	6 050	6 900	9 400	48.3	51	1.27	116.9	113.0	133.2	140.8	108.5	141.5	144.5	1.5	1	7020U
7021U	105	160	26	2	1	91.5	85.5	9 300	8 750	68.0	6 900	6 500	8 800	51.5	70	1.58	123.5	119.2	141.5	150.0	115	150	154.5	2	1	7021U
7022U	110	170	28	2	1	105	97.5	10 700	9 950	79.5	8 100	6 100	8 400	54.6	83	1.98	130.2	125.4	149.9	159.1	120	160	164.5	2	1	7022U
7024U	120	180	28	2	1	107	103	10 900	10 500	83.5	8 500	5 700	7 800	57.5	90	2.11	140.2	135.4	159.9	169.1	130	170	174.5	2	1	7024U
7026U	130	200	33	2	1	134	131	13 700	13 400	106	10 800	5 200	7 100	64.4	131	3.25	153.9	148.5	176.2	186.7	140	190	194.5	2	1	7026U
7028U	140	210	33	2	1	137	139	13 900	14 100	109	11 100	4 900	6 700	67.3	144	3.38	164.0	158.7	186.3	196.7	150	200	204.5	2	1	7028U

1) Minimum allowable value for corner radius dimension r or r_1 .

Angular Contact Ball Bearings for Radial Loads

Dynamic equivalent radial load
 $P_r = X F_r + Y F_a$

e	Single row / Tandem				Back-to-back / Face-to-face			
	$F_a/F_r \leq e$	$F_a/F_r > e$	$F_a/F_r \leq e$	$F_a/F_r > e$	$F_a/F_r \leq e$	$F_a/F_r > e$	$F_a/F_r \leq e$	$F_a/F_r > e$
0.8	X	Y	X	Y	X	Y	X	Y
	1	0	0.39	0.76	1	0.78	0.63	1.24

Static equivalent radial load
 $P_{0r} = X_0 F_r + Y_0 F_a$

e	Single row / Tandem		Back-to-back / Face-to-face	
	X_0	Y_0	X_0	Y_0
	0.5	0.33	1	0.66

When $P_{0r} < F_r$ with single-row or tandem arrangement, $P_{0r} = F_r$.

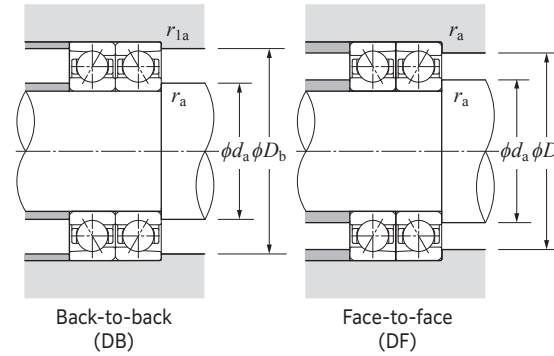

Main Spindle Bearings

Main Spindle Bearings

Angular Contact Ball Bearings for Radial Loads

Dimension Tables



Standard angular contact ball bearings (steel ball spec.) 72 type

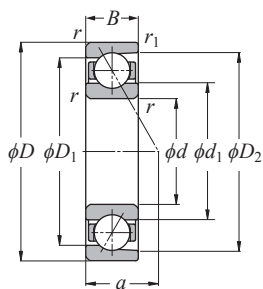

Contact angle 15° *d* 10–130 mm

Part number	Boundary dimensions					Basic load ratings				Allowable axial load		Factor <i>f₀</i>	Allowable speed		Reference dimensions			Abutment and fillet dimensions					Part number			
	mm					dynamic kN	static kgf	dynamic kgf	static kN	kN	kgf		grease lubrication	oil lubrication	mm	mm	mm	mm	mm	mm	mm	mm				
	<i>d</i>	<i>D</i>	<i>B</i>	<i>r_{s min}</i> ¹⁾	<i>r_{is min}</i> ¹⁾	<i>C_r</i>	<i>C_{0r}</i>	<i>C_r</i>	<i>C_{0r}</i>	(static)		<i>f₀</i>		<i>a</i>	Single-row (approx.)	Single-row (approx.)	<i>d₁</i>	<i>D₁</i>	<i>D₂</i>	<i>d_{a min}</i>	<i>D_{a max}</i>	<i>D_{b max}</i>	<i>r_{as max}</i>	<i>r_{1as max}</i>		
7200C	10	30	9	0.6	0.3	6.00	2.64	610	269	1.01	103	13.4	42 900	55 600	7.3	0.9	0.029	17.4	23.5	25.5	14.5	25.5	27.5	0.6	0.3	7200C
7201C	12	32	10	0.6	0.3	7.85	3.45	800	355	1.59	162	12.9	40 000	51 800	8.0	1.3	0.036	18.4	25.6	27.8	16.5	27.5	29.5	0.6	0.3	7201C
7202C	15	35	11	0.6	0.3	9.95	4.50	1020	460	1.89	193	12.9	35 200	45 600	8.9	1.5	0.045	20.8	29.0	31.6	19.5	30.5	32.5	0.6	0.3	7202C
7203C	17	40	12	0.6	0.3	12.4	5.75	1260	590	2.67	272	13.0	30 500	39 600	9.9	2.1	0.062	24.2	33.2	36.2	21.5	35.5	37.5	0.6	0.3	7203C
7204C	20	47	14	1	0.6	16.2	8.15	1650	835	3.70	375	13.4	25 500	33 000	11.6	3.1	0.10	29.4	39.4	42.8	25.5	41.5	42.5	1	0.6	7204C
7205C	25	52	15	1	0.6	18.4	10.2	1870	1050	3.75	385	14.0	22 600	29 200	12.7	4.1	0.12	33.8	44.2	47.3	30.5	46.5	47.5	1	0.6	7205C
7206C	30	62	16	1	0.6	25.5	14.7	2600	1500	7.10	725	14.0	18 900	24 500	14.3	6.6	0.19	40.6	52.2	56.4	35.5	56.5	57.5	1	0.6	7206C
7207C	35	72	17	1.1	0.6	33.5	19.9	3450	2030	10.6	1090	13.9	16 400	21 300	15.7	8.8	0.27	46.8	60.2	65.0	42	65	67.5	1	0.6	7207C
7208C	40	80	18	1.1	0.6	40.5	25.2	4100	2570	14.4	1470	14.2	14 700	19 000	17.1	11	0.35	53.0	67.0	72.3	47	73	75.5	1	0.6	7208C
7209C	45	85	19	1.1	0.6	45.0	28.8	4600	2940	14.8	1510	14.2	13 500	17 500	18.2	14	0.40	57.3	72.5	78.1	52	78	80.5	1	0.6	7209C
7210C	50	90	20	1.1	0.6	47.5	31.5	4850	3250	15.3	1560	14.5	12 600	16 300	19.4	17	0.45	62.2	77.6	83.2	57	83	85.5	1	0.6	7210C
7211C	55	100	21	1.5	1	58.5	40.0	6000	4100	21.6	2200	14.5	11 400	14 700	20.9	21	0.59	69.0	86.0	92.3	63.5	91.5	94.5	1.5	1	7211C
7212C	60	110	22	1.5	1	71.0	49.5	7250	5050	26.1	2660	14.5	10 200	13 200	22.6	28	0.76	77.0	96.0	102.9	68.5	101.5	104.5	1.5	1	7212C
7213C	65	120	23	1.5	1	77.5	55.0	7900	5600	28.5	2910	14.6	9 500	12 300	23.9	34	0.95	82.5	102.5	109.7	73.5	111.5	114.5	1.5	1	7213C
7214C	70	125	24	1.5	1	84.0	60.0	8600	6150	31.0	3150	14.6	9 000	11 700	25.1	40	1.04	87.0	108.0	115.5	78.5	116.5	119.5	1.5	1	7214C
7215C	75	130	25	1.5	1	88.0	65.5	8950	6700	33.5	3400	14.8	8 500	11 000	26.4	43	1.14	93.0	114.0	121.5	83.5	121.5	124.5	1.5	1	7215C
7216C	80	140	26	2	1	103	77.5	10500	7900	34.5	3550	14.7	8 000	10 400	27.8	54	1.39	98.1	121.4	129.6	90	130	134.5	2	1	7216C
7217C	85	150	28	2	1	115	90.5	11800	9200	46.5	4750	14.9	7 500	9 700	29.9	63	1.73	106.1	129.9	138.5	95	140	144.5	2	1	7217C
7218C	90	160	30	2	1	136	105	13900	10700	53.5	5450	14.6	7 000	9 100	31.8	80	2.13	111.6	138.5	147.9	100	150	154.5	2	1	7218C
7219C	95	170	32	2.1	1.1	154	120	15700	12200	62.0	6350	14.6	6 600	8 600	33.8	96	2.58	118.2	146.8	157.0	107	158	163	2	1	7219C
7220C	100	180	34	2.1	1.1	165	127	16800	12900	67.0	6800	14.5	6 300	8 100	35.8	119	3.21	124.8	155.2	166.2	112	168	173	2	1	7220C
7221CT1B	105	190	36	2.1	1.1	180	143	18300	14600	74.5	7600	14.5	6 000	7 700	37.8	147	3.81	131.3	163.7	175.3	117	178	183	2	1	7221CT1B
7222CT1B	110	200	38	2.1	1.1	195	160	19900	16300	86.0	8800	14.5	5 700	7 400	39.9	171	4.49	138.0	172.0	184.4	122	188	193	2	1	7222CT1B
7224CT1B	120	215	40	2.1	1.1	220	192	22400	19600	91.5	9300	14.6	5 300	6 800	42.5	206	5.44	149.0	186.0	198.6	132	203	208	2	1	7224CT1B
7226CT1B	130	230	40	3	1.1	236	214	24100	21800	111	11300	14.7	4 900	6 300	44.2	232	6.19	161.0	199.0	212.6	144	216	223	2.5	1	7226CT1B

1) Minimum allowable value for corner radius dimension *r* or *r₁*.

Angular Contact Ball Bearings for Radial Loads

Dimension Tables

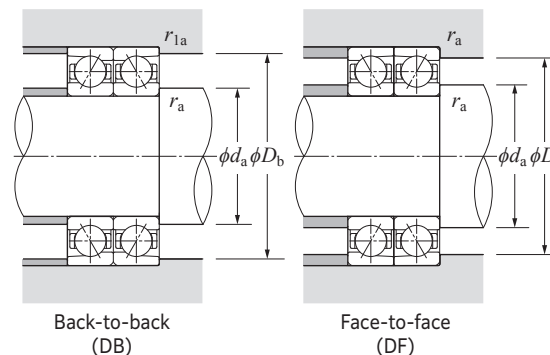

Dynamic equivalent radial load

$$P_r = X F_r + Y F_a$$

<i>i</i> <i>f₀</i> <i>F_a</i>	<i>e</i>	Single row / Tandem				Back-to-back / Face-to-face			
		<i>F_a/F_r ≤ e</i>		<i>F_a/F_r > e</i>		<i>F_a/F_r ≤ e</i>		<i>F_a/F_r > e</i>	
		<i>X</i>	<i>Y</i>	<i>X</i>	<i>Y</i>	<i>X</i>	<i>Y</i>	<i>X</i>	<i>Y</i>
0.178	0.38				1.47			1.65	2.39
0.357	0.4				1.4			1.57	2.28
0.714	0.43				1.3			1.46	2.11
1.07	0.46				1.23			1.38	2
1.43	0.47				1.19		1	1.34	1.93
2.14	0.5	1	0	0.44	1.12			1.26	1.82
3.57	0.55				1.02			1.14	1.66
5.35	0.56				1			1.12	1.63
7.14	0.56				1			1.12	1.63

Static equivalent radial load

$$P_{0r} = X_0 F_r + Y_0 F_a$$

Single row / Tandem		Back-to-back / Face-to-face	
<i>X₀</i>	<i>Y₀</i>	<i>X₀</i>	<i>Y₀</i>
0.5	0.46	1	0.92

When $P_r < F_r$ with single-row or tandem arrangement, $P_{0r} = F_r$.

Angular Contact Ball Bearings for Radial Loads Dimension Tables



ULTAGE Standard angular contact ball bearings (ceramic ball spec.)
5S-79U type

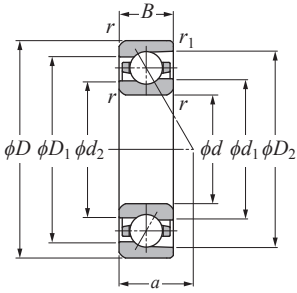

Contact angle 15° d 10–130 mm

Part number	Boundary dimensions						Basic load ratings				Allowable axial load		Factor f_0	Allowable speed		Load center a	Internal free space S	Mass	Reference dimensions				Abutment and fillet dimensions					Part number
	mm						dynamic	static	dynamic	static	(static)	min ⁻¹		mm					mm									
	d	D	B	r_s	r_{1s}	C_r	C_{0r}	C_r	C_{0r}	C_r		C_{0r}		grease lubrication	oil lubrication				d_1	d_2	D_1	D_2	d_a	D_a	d_b	r_{as}	r_{1as}	
				min ¹	min ¹																	min	max	max	max	max	max	
5S-7900UC	10	22	6	0.3	0.15	3.55	1.15	360	117	1.94	198	9.8	84 000	136 800	5.2	0.4	0.009	14.3	13.5	17.7	19.4	12.5	19.5	20.8	0.3	0.15	5S-7900UC	
5S-7901UC	12	24	6	0.3	0.15	3.70	1.29	380	131	2.18	223	10.2	74 600	121 600	5.4	0.4	0.010	16.3	15.5	19.7	21.3	14.5	21.5	22.8	0.3	0.15	5S-7901UC	
5S-7902UC	15	28	7	0.3	0.15	5.65	2.01	575	205	3.40	345	10.0	62 500	101 900	6.4	0.8	0.013	19.3	18.3	23.7	25.6	17.5	25.5	26.8	0.3	0.15	5S-7902UC	
5S-7903UC	17	30	7	0.3	0.15	5.90	2.22	605	226	3.75	385	10.3	57 200	93 200	6.7	0.8	0.015	21.3	20.3	25.7	27.8	19.5	27.5	28.8	0.3	0.15	5S-7903UC	
5S-7904UC	20	37	9	0.3	0.15	8.45	3.40	865	345	5.75	585	10.3	47 100	76 800	8.3	1.5	0.033	25.9	24.7	31.1	33.6	22.5	34.5	35.8	0.3	0.15	5S-7904UC	
5S-7905UC	25	42	9	0.3	0.15	9.05	4.00	925	405	6.80	695	10.7	40 100	65 400	9.0	1.8	0.039	30.9	29.7	36.1	38.6	27.5	39.5	40.8	0.3	0.15	5S-7905UC	
5S-7906UC	30	47	9	0.3	0.15	9.55	4.60	975	470	7.85	800	11.0	34 900	56 900	9.7	2.0	0.044	35.9	34.7	41.1	43.6	32.5	44.5	45.8	0.3	0.15	5S-7906UC	
5S-7907UC	35	55	10	0.6	0.3	15.2	7.10	1 550	725	12.1	1 240	10.7	29 900	48 700	11.1	3.4	0.062	41.6	39.9	48.4	51.7	39.5	50.5	52.5	0.6	0.3	5S-7907UC	
5S-7908UC	40	62	12	0.6	0.3	16.0	8.15	1 640	830	13.9	1 420	11.0	26 300	42 900	12.9	4.7	0.10	47.6	45.9	54.4	57.8	44.5	57.5	59.5	0.6	0.3	5S-7908UC	
5S-7909UC	45	68	12	0.6	0.3	19.9	10.3	2 030	1 050	17.6	1 790	11.0	23 800	38 800	13.6	5.9	0.11	52.7	50.8	60.4	64.1	49.5	63.5	65.5	0.6	0.3	5S-7909UC	
5S-7910UC	50	72	12	0.6	0.3	21.0	11.5	2 140	1 180	19.7	2 010	11.1	22 000	35 900	14.2	6.2	0.11	57.2	55.3	64.9	68.6	54.5	67.5	69.5	0.6	0.3	5S-7910UC	
5S-7911UC	55	80	13	1	0.6	21.8	12.8	2 230	1 310	22.0	2 240	11.3	19 900	32 400	15.6	7.5	0.16	63.7	61.8	71.4	75.1	60.5	74.5	75.5	1	0.6	5S-7911UC	
5S-7912UC	60	85	13	1	0.6	22.7	14.1	2 320	1 440	24.2	2 460	11.4	18 500	30 200	16.3	8.0	0.17	68.7	66.8	76.4	80.1	65.5	79.5	80.5	1	0.6	5S-7912UC	
5S-7913UC	65	90	13	1	0.6	23.0	14.7	2 350	1 500	25.4	2 590	11.4	17 300	28 300	16.9	8.6	0.19	73.7	71.8	81.4	85.1	70.5	84.5	85.5	1	0.6	5S-7913UC	
5S-7914UC	70	100	16	1	0.6	33.0	20.9	3 350	2 140	36.0	3 650	11.4	15 800	25 800	19.4	14	0.30	80.3	78.0	89.7	94.3	75.5	94.5	95.5	1	0.6	5S-7914UC	
5S-7915UC	75	105	16	1	0.6	33.5	22.0	3 400	2 240	37.5	3 850	11.5	14 900	24 300	20.1	15	0.32	85.3	83.0	94.7	99.3	80.5	99.5	100.5	1	0.6	5S-7915UC	
5S-7916UC	80	110	16	1	0.6	34.0	22.7	3 450	2 320	39.5	4 000	11.4	14 100	22 900	20.8	16	0.33	90.8	88.5	100.2	104.8	85.5	104.5	105.5	1	0.6	5S-7916UC	
5S-7917UC	85	120	18	1.1	0.6	45.5	30.5	4 650	3 100	52.0	5 350	11.4	13 100	21 400	22.8	22	0.47	96.9	94.3	108.1	113.4	92	113	115.5	1	0.6	5S-7917UC	
5S-7918UC	90	125	18	1.1	0.6	46.0	32.0	4 700	3 250	54.5	5 550	11.5	12 500	20 400	23.5	23	0.49	101.9	99.3	113.1	118.4	97	118	120.5	1	0.6	5S-7918UC	
5S-7919UC	95	130	18	1.1	0.6	47.0	33.0	4 750	3 350	57.0	5 800	11.4	11 900	19 500	24.1	24	0.52	106.9	104.3	118.1	123.4	102	123	125.5	1	0.6	5S-7919UC	
5S-7920UC	100	140	20	1.1	0.6	60.0	42.5	6 150	4 300	72.5	7 400	11.4	11 200	18 200	26.1	33	0.70	113.6	110.5	126.4	132.6	107	133	135.5	1	0.6	5S-7920UC	
5S-7921UC	105	145	20	1.1	0.6	61.0	44.0	6 250	4 500	75.5	7 700	11.5	10 800	17 500	26.8	34	0.73	118.6	115.5	131.4	137.6	112	138	140.5	1	0.6	5S-7921UC	
5S-7922UC	110	150	20	1.1	0.6	62.0	45.5	6 300	4 650	78.5	8 050	11.4	10 300	16 800	27.5	36	0.76	123.6	120.5	136.4	142.6	117	143	145.5	1	0.6	5S-7922UC	
5S-7924UC	120	165	22	1.1	0.6	76.5	56.5	7 800	5 750	97.0	9 900	11.5	9 400	15 400	30.2	48	1.03	135.2	131.7	149.8	156.7	127	158	160.5	1	0.6	5S-7924UC	
5S-7926UC	130	180	24	1.5	1	94.0	70.5	9 600	7 200	121	12 300	11.5	8 700	14 100	32.9	63	1.34	146.9	143.0	163.2	170.9	138.5	171.5	174.5	1.5	1	5S-7926UC	

1) Minimum allowable value for corner radius dimension r or r_1 .

Angular Contact Ball Bearings for Radial Loads Dimension Tables



Dynamic equivalent radial load
 $P_r = XF_r + YF_a$

$i \cdot f_0 \cdot F_a$	C_{0r}	e	Single row / Tandem				Back-to-back / Face-to-face			
			$F_a/F_r \leq e$		$F_a/F_r > e$		$F_a/F_r \leq e$		$F_a/F_r > e$	
			X	Y	X	Y	X	Y	X	Y
0.178	0.38				1.47	1.65	2.39			
0.357	0.4			1.4	1.57	2.28				
0.714	0.43			1.3	1.46	2.11				
1.07	0.46			1.23	1.38	2				
1.43	0.47			1.19	1.34	1.93				
2.14	0.5	1	0	1.12	1.26	1.82				
3.57	0.55		0.44	1.02	1.14	1.66				
5.35	0.56			1	1.12	1.63				
7.14	0.56			1	1.12	1.63				

Static equivalent radial load
 $P_{0r} = X_0 F_r + Y_0 F_a$

Single row / Tandem		Back-to-back / Face-to-face	
X_0	Y_0	X_0	Y_0
0.5	0.46	1	0.92

When $P_{0r} < F_r$ with single-row or tandem arrangement, $P_{0r} = F_r$.

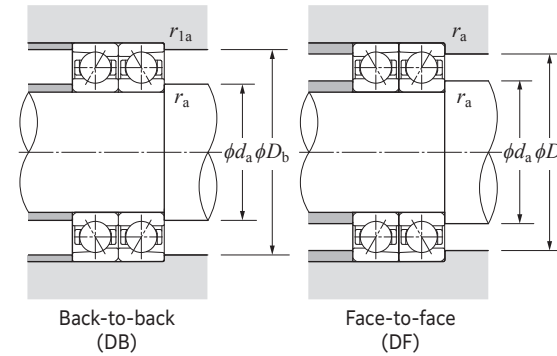

Angular Contact Ball Bearings for Radial Loads

ULTAGE Standard angular contact ball bearings (ceramic ball spec.)
5S-79U type

Dimension
Tables

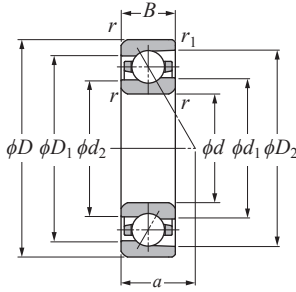

Contact angle 25° d 10–130 mm

Part number	Boundary dimensions						Basic load ratings				Allowable axial load		Allowable speed		Load center mm	Internal free space cm ³	Mass kg	Reference dimensions				Abutment and fillet dimensions					Part number
	mm						dynamic kN	static kN	dynamic kgf	static kgf	(static)		grease lubrication	oil lubrication				mm				mm					
	<i>d</i>	<i>D</i>	<i>B</i>	r_s min ¹⁾	r_{1s} min ¹⁾		C_{0r}	C_r	C_{0r}	C_r					<i>a</i>	Single-row (approx.)	Single-row (approx.)	d_1	d_2	D_1	D_2	d_a min	D_a max	D_b max	r_{as} max	r_{1as} max	
5S-7900UAD	10	22	6	0.3	0.15		3.40	1.10	345	112	2.12	216	73 200	120 100	6.8	0.4	0.009	14.3	13.5	17.7	19.4	12.5	19.5	20.8	0.3	0.15	5S-7900UAD
5S-7901UAD	12	24	6	0.3	0.15		3.55	1.23	360	125	2.30	234	65 100	106 800	7.2	0.4	0.010	16.3	15.5	19.7	21.3	14.5	21.5	22.8	0.3	0.15	5S-7901UAD
5S-7902UAD	15	28	7	0.3	0.15		5.40	1.92	550	196	3.35	345	54 500	89 400	8.6	0.8	0.013	19.3	18.3	23.7	25.6	17.5	25.5	26.8	0.3	0.15	5S-7902UAD
5S-7903UAD	17	30	7	0.3	0.15		5.60	2.12	575	216	3.60	370	49 800	81 800	9.0	0.8	0.015	21.3	20.3	25.7	27.7	19.5	27.5	28.8	0.3	0.15	5S-7903UAD
5S-7904UAD	20	37	9	0.3	0.15		8.05	3.25	820	330	5.60	575	41 100	67 400	11.2	1.5	0.033	25.9	24.7	31.1	33.6	22.5	34.5	35.8	0.3	0.15	5S-7904UAD
5S-7905UAD	25	42	9	0.3	0.15		8.60	3.80	875	385	6.40	650	35 000	57 400	12.4	1.8	0.039	30.9	29.7	36.1	38.6	27.5	39.5	40.8	0.3	0.15	5S-7905UAD
5S-7906UAD	30	47	9	0.3	0.15		9.00	4.35	920	445	7.15	730	30 400	49 900	13.5	2.0	0.044	35.9	34.7	41.1	43.6	32.5	44.5	45.8	0.3	0.15	5S-7906UAD
5S-7907UAD	35	55	10	0.6	0.3		14.4	6.75	1 470	690	12.1	1 240	26 000	42 700	15.6	3.4	0.062	41.6	39.9	48.4	51.7	39.5	50.5	52.5	0.6	0.3	5S-7907UAD
5S-7908UAD	40	62	12	0.6	0.3		15.2	7.75	1 550	790	13.6	1 380	23 000	37 700	18.0	4.7	0.100	47.6	45.9	54.4	57.8	44.5	57.5	59.5	0.6	0.3	5S-7908UAD
5S-7909UAD	45	68	12	0.6	0.3		18.8	9.75	1 920	995	17.5	1 790	20 700	34 000	19.2	5.9	0.110	52.7	50.8	60.4	64.0	49.5	63.5	65.5	0.6	0.3	5S-7909UAD
5S-7910UAD	50	72	12	0.6	0.3		19.8	10.9	2 020	1 110	19.3	1 970	19 200	31 500	20.3	6.2	0.110	57.2	55.3	64.9	68.5	54.5	67.5	69.5	0.6	0.3	5S-7910UAD
5S-7911UAD	55	80	13	1	0.6		20.6	12.2	2 100	1 240	21.1	2 160	17 400	28 500	22.3	7.5	0.160	63.7	61.8	71.4	75.1	60.5	74.5	75.5	1	0.6	5S-7911UAD
5S-7912UAD	60	85	13	1	0.6		21.4	13.2	2 190	1 350	23.0	2 340	16 200	26 500	23.5	8.0	0.170	68.7	66.8	76.4	80.1	65.5	79.5	80.5	1	0.6	5S-7912UAD
5S-7913UAD	65	90	13	1	0.6		21.7	13.7	2 210	1 390	23.9	2 430	15 100	24 800	24.6	8.6	0.190	73.7	71.8	81.4	85.0	70.5	84.5	85.5	1	0.6	5S-7913UAD
5S-7914UAD	70	100	16	1	0.6		31.0	19.8	3 150	2 020	33.5	3 400	13 800	22 600	27.9	14	0.300	80.3	78	89.7	94.3	75.5	94.5	95.5	1	0.6	5S-7914UAD
5S-7915UAD	75	105	16	1	0.6		31.5	20.5	3 200	2 090	34.5	3 550	13 000	21 400	29.1	15	0.320	85.3	83	94.7	99.2	80.5	99.5	100.5	1	0.6	5S-7915UAD
5S-7916UAD	80	110	16	1	0.6		32.0	21.2	3 250	2 160	36.0	3 700	12 300	20 100	30.4	16	0.330	90.8	88.5	100.2	104.7	85.5	104.5	105.5	1	0.6	5S-7916UAD
5S-7917UAD	85	120	18	1.1	0.6		43.0	28.8	4 350	2 940	47.0	4 800	11 400	18 800	33.0	22	0.470	96.9	94.3	108.1	113.4	92	113	115.5	1	0.6	5S-7917UAD
5S-7918UAD	90	125	18	1.1	0.6		43.5	29.7	4 450	3 050	49.0	5 000	10 900	17 900	34.2	23	0.490	101.9	99.3	113.1	118.4	97	118	120.5	1	0.6	5S-7918UAD
5S-7919UAD	95	130	18	1.1	0.6		44.0	30.5	4 500	3 150	51.0	5 200	10 400	17 100	35.3	24	0.520	106.9	104.3	118.1	123.4	102	123	125.5	1	0.6	5S-7919UAD
5S-7920UAD	100	140	20	1.1	0.6		56.5	39.5	5 800	4 050	67.5	6 850	9 800	16 000	38.1	33	0.700	113.6	110.5	126.4	132.5	107	133	135.5	1	0.6	5S-7920UAD
5S-7921UAD	105	145	20	1.1	0.6		57.5	41.0	5 850	4 200	70.0	7 100	9 400	15 400	39.3	34	0.730	118.6	115.5	131.4	137.5	112	138	140.5	1	0.6	5S-7921UAD
5S-7922UAD	110	150	20	1.1	0.6		58.5	42.5	5 950	4 300	72.5	7 400	9 000	14 800	40.4	36	0.760	123.6	120.5	136.4	142.5	117	143	145.5	1	0.6	5S-7922UAD
5S-7924UAD	120	165	22	1.1	0.6		72.0	52.5	7 350	5 350	88.0	8 950	8 200	13 500	44.4	48	1.03	135.2	131.7	149.8	156.7	127	158	160.5	1	0.6	5S-7924UAD
5S-7926UAD	130	180	24	1.5	1		88.5	66.0	9 050	6 750	112	11 400	7 600	12 400	48.3	63	1.34	146.9	143	163.2	170.8	138.5	171.5	174.5	1.5	1	5S-7926UAD

1) Minimum allowable value for corner radius dimension r or r_1 .

Angular Contact Ball Bearings for Radial Loads

Dynamic equivalent radial load
 $P_r = X F_r + Y F_a$

e	Single row / Tandem		Back-to-back / Face-to-face			
	$F_a/F_r \leq e$	$F_a/F_r > e$	$F_a/F_r \leq e$	$F_a/F_r > e$	$F_a/F_r \leq e$	$F_a/F_r > e$
	X	Y	X	Y	X	Y
0.68	1	0	0.41	0.87	1	0.92
			0.67	1.41		

Static equivalent radial load
 $P_{0r} = X_0 F_r + Y_0 F_a$

e	Single row / Tandem		Back-to-back / Face-to-face	
	X_0	Y_0	X_0	Y_0
0.5	0.5	0.38	1	0.76

When $P_{0r} < F_r$ with single-row or tandem arrangement, $P_{0r} = F_r$.

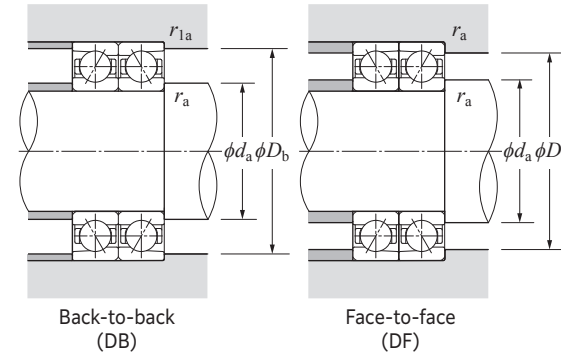

Back-to-back (DB)

Face-to-face (DF)

Angular Contact Ball Bearings for Radial Loads

ULTAGE Standard angular contact ball bearings (ceramic ball spec.)
5S-79U type

Dimension Tables

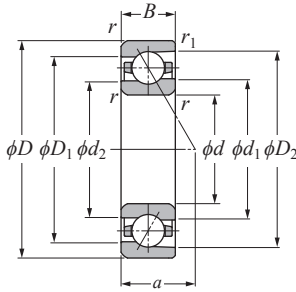

Contact angle 30° d 10–130 mm

Part number	Boundary dimensions					Basic load ratings				Allowable axial load		Allowable speed		Load center mm	Internal free space cm ³	Mass kg	Reference dimensions				Abutment and fillet dimensions					Part number
	mm					dynamic kN	static kgf	dynamic kN	static kgf	kN	kgf	grease lubrication	oil lubrication				mm				mm					
	d	D	B	r_s min ¹⁾	r_{1s} min ¹⁾	C_r	C_{0r}	C_r	C_{0r}	(static)				a	Single-row (approx.)	Single-row (approx.)	d_1	d_2	D_1	D_2	d_a min	D_a max	D_b max	r_{as}	r_{1as} max	
5S-7900U	10	22	6	0.3	0.15	3.25	1.06	335	108	1.63	166	58 600	78 000	7.7	0.4	0.009	14.3	13.5	17.7	19.3	12.5	19.5	20.8	0.3	0.15	5S-7900U
5S-7901U	12	24	6	0.3	0.15	3.40	1.19	350	121	1.77	181	52 100	69 400	8.2	0.4	0.010	16.3	15.5	19.7	21.3	14.5	21.5	22.8	0.3	0.15	5S-7901U
5S-7902U	15	28	7	0.3	0.15	5.20	1.86	530	190	2.56	261	43 600	58 100	9.8	0.8	0.013	19.3	18.3	23.7	25.6	17.5	25.5	26.8	0.3	0.15	5S-7902U
5S-7903U	17	30	7	0.3	0.15	5.40	2.05	555	209	2.74	280	39 900	53 100	10.3	0.8	0.015	21.3	20.3	25.7	27.7	19.5	27.5	28.8	0.3	0.15	5S-7903U
5S-7904U	20	37	9	0.3	0.15	7.75	3.10	790	320	4.30	440	32 900	43 800	12.8	1.5	0.033	25.9	24.7	31.1	33.5	22.5	34.5	35.8	0.3	0.15	5S-7904U
5S-7905U	25	42	9	0.3	0.15	8.25	3.65	840	375	4.90	500	28 000	37 300	14.2	1.8	0.039	30.9	29.7	36.1	38.5	27.5	39.5	40.8	0.3	0.15	5S-7905U
5S-7906U	30	47	9	0.3	0.15	8.65	4.20	885	430	5.50	560	24 300	32 400	15.7	2.0	0.044	35.9	34.7	41.1	43.5	32.5	44.5	45.8	0.3	0.15	5S-7906U
5S-7907U	35	55	10	0.6	0.3	13.8	6.50	1410	665	9.35	955	20 800	27 800	18.1	3.4	0.062	41.6	39.9	48.4	51.6	39.5	50.5	52.5	0.6	0.3	5S-7907U
5S-7908U	40	62	12	0.6	0.3	14.6	7.45	1490	760	10.5	1070	18 400	24 500	20.8	4.7	0.10	47.6	45.9	54.4	57.7	44.5	57.5	59.5	0.6	0.3	5S-7908U
5S-7909U	45	68	12	0.6	0.3	18.1	9.40	1840	960	13.6	1390	16 600	22 100	22.4	5.9	0.11	52.7	50.8	60.4	64.0	49.5	63.5	65.5	0.6	0.3	5S-7909U
5S-7910U	50	72	12	0.6	0.3	19.0	10.5	1940	1070	15.0	1530	15 400	20 500	23.7	6.2	0.11	57.2	55.3	64.9	68.5	54.5	67.5	69.5	0.6	0.3	5S-7910U
5S-7911U	55	80	13	1	0.6	19.8	11.7	2020	1190	16.5	1680	13 900	18 500	26.1	7.5	0.16	63.7	61.8	71.4	75.0	60.5	74.5	75.5	1	0.6	5S-7911U
5S-7912U	60	85	13	1	0.6	20.6	12.6	2100	1280	18.0	1830	12 900	17 200	27.5	8.0	0.17	68.7	66.8	76.4	80.1	65.5	79.5	80.5	1	0.6	5S-7912U
5S-7913U	65	90	13	1	0.6	20.8	13.0	2120	1330	18.7	1910	12 100	16 100	29.0	8.6	0.19	73.7	71.8	81.4	85.0	70.5	84.5	85.5	1	0.6	5S-7913U
5S-7914U	70	100	16	1	0.6	29.8	18.9	3050	1930	25.7	2620	11 000	14 700	32.6	14	0.30	80.3	78.0	89.7	94.2	75.5	94.5	95.5	1	0.6	5S-7914U
5S-7915U	75	105	16	1	0.6	30.0	19.5	3100	1990	26.7	2730	10 400	13 900	34.1	15	0.32	85.3	83.0	94.7	99.2	80.5	99.5	100.5	1	0.6	5S-7915U
5S-7916U	80	110	16	1	0.6	30.5	20.2	3100	2050	27.8	2830	9 800	13 100	35.7	16	0.30	90.8	88.5	100.2	104.7	85.5	104.5	105.5	1	0.6	5S-7916U
5S-7917U	85	120	18	1.1	0.6	41.0	27.4	4200	2790	36.0	3700	9 100	12 200	38.7	22	0.47	96.9	94.3	108.1	113.4	92	113	115.5	1	0.6	5S-7917U
5S-7918U	90	125	18	1.1	0.6	41.5	28.3	4250	2880	37.5	3850	8 700	11 600	40.2	23	0.49	101.9	99.3	113.1	118.3	97	118	120.5	1	0.6	5S-7918U
5S-7919U	95	130	18	1.1	0.6	42.5	29.2	4300	2980	39.0	4000	8 300	11 100	41.6	24	0.52	106.9	104.3	118.1	123.3	102	123	125.5	1	0.6	5S-7919U
5S-7920U	100	140	20	1.1	0.6	54.5	38.0	5550	3850	52.0	5300	7 800	10 400	44.8	33	0.70	113.6	110.5	126.4	132.5	107	133	135.5	1	0.6	5S-7920U
5S-7921U	105	145	20	1.1	0.6	55.0	39.0	5650	4000	54.0	5500	7 500	10 000	46.2	34	0.73	118.6	115.5	131.4	137.5	112	138	140.5	1	0.6	5S-7921U
5S-7922U	110	150	20	1.1	0.6	56.0	40.5	5700	4100	56.0	5700	7 200	9 600	47.7	36	0.76	123.6	120.5	136.4	142.5	117	143	145.5	1	0.6	5S-7922U
5S-7924U	120	165	22	1.1	0.6	69.0	50.0	7050	5100	67.5	6900	6 600	8 800	52.3	48	1.03	135.2	131.7	149.8	156.6	127	158	160.5	1	0.6	5S-7924U
5S-7926U	130	180	24	1.5	1	85.0	62.5	8650	6400	86.5	8850	6 000	8 100	56.9	63	1.34	146.9	143.0	163.2	170.8	138.5	171.5	174.5	1.5	1	5S-7926U

1) Minimum allowable value for corner radius dimension r or r_1 .

Angular Contact Ball Bearings for Radial Loads

Dimension Tables



Dynamic equivalent radial load
 $P_r = XF_r + YF_a$

e	Single row / Tandem				Back-to-back / Face-to-face			
	$F_a/F_r \leq e$	$F_a/F_r > e$	$F_a/F_r \leq e$	$F_a/F_r > e$	$F_a/F_r \leq e$	$F_a/F_r > e$	$F_a/F_r \leq e$	$F_a/F_r > e$
0.8	X	Y	X	Y	X	Y	X	Y
	1	0	0.39	0.76	1	0.78	0.63	1.24

Static equivalent radial load
 $P_{0r} = X_0 F_r + Y_0 F_a$

e	Single row / Tandem		Back-to-back / Face-to-face	
	X_0	Y_0	X_0	Y_0
	0.5	0.33	1	0.66

When $P_{0r} < F_r$ with single-row or tandem arrangement, $P_{0r} = F_r$.

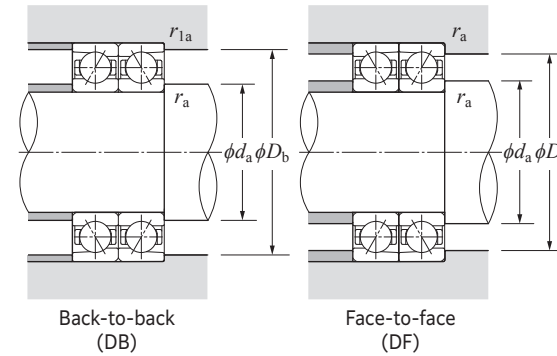

Angular Contact Ball Bearings for Radial Loads

Dimension Tables



ULTAGE Standard angular contact ball bearings (ceramic ball spec.)
5S-70U type

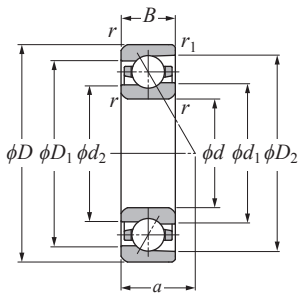

Contact angle 15° d 10–140 mm

Part number	Boundary dimensions					Basic load ratings				Allowable axial load		Factor f_0	Allowable speed		Reference dimensions				Abutment and fillet dimensions					Part number			
	mm					dynamic kN	static kgf	dynamic kgf	static kN	(static)			grease lubrication	oil lubrication	mm				mm								
	d	D	B	$r_{s\min}^1$	$r_{is\min}^1$	C_T	C_{0r}	C_T	C_{0r}			f_0		a	Internal free space cm^3	Mass kg	d_1	d_2	D_1	D_2	d_a min	D_a max	D_b max	r_{as} max	r_{1as} max		
5S-7000UC	10	26	8	0.3	0.15	5.90	1.72	600	175	2.88	293	8.7	75 500	123 000	6.4	0.9	0.017	15.2	14.0	20.4	22.7	12.5	23.5	24.8	0.3	0.15	5S-7000UC
5S-7001UC	12	28	8	0.3	0.15	6.45	2.03	655	207	3.40	350	9.3	65 500	106 800	6.8	1.0	0.018	17.9	16.7	23.1	25.4	14.5	25.5	26.8	0.3	0.15	5S-7001UC
5S-7002UC	15	32	9	0.3	0.15	7.35	2.56	750	261	4.35	440	9.7	57 200	93 200	7.7	1.3	0.027	20.9	19.7	26.1	28.5	17.5	29.5	30.8	0.3	0.15	5S-7002UC
5S-7003UC	17	35	10	0.3	0.15	9.10	3.15	930	320	5.30	540	9.6	51 700	84 200	8.5	1.8	0.033	23.0	21.6	29.0	32.0	19.5	32.5	33.8	0.3	0.15	5S-7003UC
5S-7004UC	20	42	12	0.6	0.3	12.3	4.55	1 250	465	7.70	785	9.8	42 700	69 500	10.3	2.9	0.060	28.1	26.4	34.9	38.4	24.5	37.5	39.5	0.6	0.3	5S-7004UC
5S-7005UC	25	47	12	0.6	0.3	13.6	5.55	1 390	565	9.40	960	10.2	37 300	60 800	10.9	3.3	0.071	32.6	30.9	39.4	42.9	29.5	42.5	44.5	0.6	0.3	5S-7005UC
5S-7006UC	30	55	13	1	0.6	17.5	7.65	1 790	780	13.0	1 320	10.3	31 200	50 900	12.3	4.8	0.10	39.2	37.3	46.9	50.6	35.5	49.5	50.5	1	0.6	5S-7006UC
5S-7007UC	35	62	14	1	0.6	22.1	10.1	2 260	1 030	17.2	1 750	10.4	27 700	45 100	13.5	6.3	0.13	44.2	42.2	52.8	57.0	40.5	56.5	57.5	1	0.6	5S-7007UC
5S-7008UC	40	68	15	1	0.6	23.7	11.7	2 410	1 190	19.9	2 020	10.6	24 900	40 500	14.8	7.4	0.17	49.7	47.7	58.3	62.5	45.5	62.5	63.5	1	0.6	5S-7008UC
5S-7009UC	45	75	16	1	0.6	28.1	14.1	2 860	1 440	24.1	2 460	10.7	22 400	36 500	16.1	9.4	0.21	55.3	53.0	64.7	69.3	50.5	69.5	70.5	1	0.6	5S-7009UC
5S-7010UC	50	80	16	1	0.6	29.8	16.0	3 050	1 630	27.3	2 780	10.9	20 700	33 700	16.8	11	0.23	60.3	58.0	69.7	74.3	55.5	74.5	75.5	1	0.6	5S-7010UC
5S-7011UC	55	90	18	1.1	0.6	39.0	20.9	4 000	2 140	35.5	3 650	10.7	18 500	30 200	18.8	16	0.33	66.9	64.3	78.1	83.5	62	83	85.5	1	0.6	5S-7011UC
5S-7012UC	60	95	18	1.1	0.6	40.0	22.4	4 100	2 280	38.0	3 900	10.9	17 300	28 300	19.4	17	0.36	71.9	69.3	83.1	88.5	67	88	90.5	1	0.6	5S-7012UC
5S-7013UC	65	100	18	1.1	0.6	42.5	24.9	4 300	2 540	42.5	4 350	11.0	16 300	26 500	20.1	18	0.38	76.9	74.3	88.1	93.5	72	93	95.5	1	0.6	5S-7013UC
5S-7014UC	70	110	20	1.1	0.6	53.5	31.5	5 450	3 200	53.5	5 450	10.9	14 900	24 300	22.1	24	0.53	83.6	80.5	96.4	102.6	77	103	105.5	1	0.6	5S-7014UC
5S-7015UC	75	115	20	1.1	0.6	55.0	33.0	5 600	3 400	56.5	5 750	11.0	14 100	23 000	22.8	26	0.56	88.6	85.5	101.4	107.6	82	108	110.5	1	0.6	5S-7015UC
5S-7016UC	80	125	22	1.1	0.6	67.0	40.0	6 850	4 100	68.5	7 000	10.9	13 100	21 400	24.8	34	0.74	95.2	91.7	109.8	116.8	87	118	120.5	1	0.6	5S-7016UC
5S-7017UC	85	130	22	1.1	0.6	69.0	42.5	7 000	4 350	72.5	7 400	11.0	12 500	20 400	25.5	36	0.78	100.2	96.7	114.8	121.8	92	123	125.5	1	0.6	5S-7017UC
5S-7018UC	90	140	24	1.5	1	82.0	50.5	8 350	5 150	86.0	8 750	10.9	11 700	19 000	27.5	47	1.00	106.9	103.0	123.2	131.0	98.5	131.5	134.5	1.5	1	5S-7018UC
5S-7019UC	95	145	24	1.5	1	84.0	53.0	8 550	5 400	90.5	9 250	11.0	11 200	18 200	28.2	49	1.04	111.9	108.0	128.2	136.0	103.5	136.5	139.5	1.5	1	5S-7019UC
5S-7020UC	100	150	24	1.5	1	86.0	56.0	8 750	5 700	95.5	9 750	11.1	10 800	17 500	28.8	51	1.09	116.9	113.0	133.2	140.9	108.5	141.5	144.5	1.5	1	5S-7020UC
5S-7021UC	105	160	26	2	1	101	65.0	10 300	6 600	111	11 300	11.0	10 100	16 500	30.8	70	1.34	123.5	119.2	141.5	150.1	115	150	154.5	2	1	5S-7021UC
5S-7022UC	110	170	28	2	1	116	74.0	11 800	7 500	126	12 800	10.9	9 600	15 600	32.9	83	1.69	130.2	125.4	149.9	159.3	120	160	164.5	2	1	5S-7022UC
5S-7024UC	120	180	28	2	1	118	78.5	12 000	8 000	134	13 600	11.1	9 000	14 600	34.2	90	1.80	140.2	135.4	159.9	169.3	130	170	174.5	2	1	5S-7024UC
5S-7026UC	130	200	33	2	1	148	99.5	15 100	10 200	170	17 300	11.0	8 100	13 300	38.7	131	2.80	153.9	148.5	176.2	186.9	140	190	194.5	2	1	5S-7026UC
5S-7028UC	140	210	33	2	1	151	105	15 400	10 700	179	18 300	11.1	7 600	12 500	40.1	144	2.90	164.0	158.7	186.3	196.8	150	200	204.5	2	1	5S-7028UC

1) Minimum allowable value for corner radius dimension r or r1.

Angular Contact Ball Bearings for Radial Loads

Dimension Tables

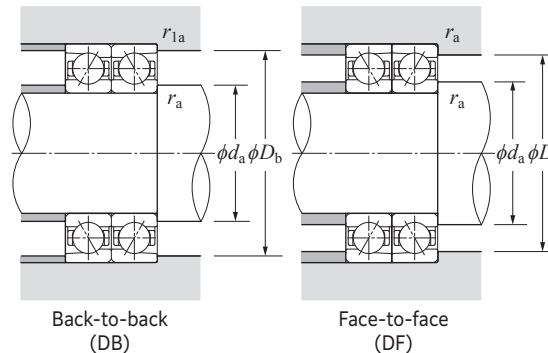

Dynamic equivalent radial load

$$P_r = X F_r + Y F_a$$

$i f_0 F_a$	e	Single row / Tandem				Back-to-back / Face-to-face			
		$F_a / F_r \leq e$		$F_a / F_r > e$		$F_a / F_r \leq e$		$F_a / F_r > e$	
		X	Y	X	Y	X	Y	X	Y
0.178	0.38				1.47			1.65	2.39
0.357	0.4				1.4			1.57	2.28
0.714	0.43				1.3			1.46	2.11
1.07	0.46				1.23			1.38	2
1.43	0.47				1.19	1	1.34	0.72	1.93
2.14	0.5	1	0	0.44	1.12		1.26		1.82
3.57	0.55				1.02		1.14		1.66
5.35	0.56				1		1.12		1.63
7.14	0.56				1		1.12		1.63

Static equivalent radial load

$$P_{0r} = X_0 F_r + Y_0 F_a$$

Single row / Tandem		Back-to-back / Face-to-face	
X_0	Y_0	X_0	Y_0
0.5	0.46	1	0.92

When $P_{0r} < F_r$ with single-row or tandem arrangement, $P_{0r} = F_r$.

Angular Contact Ball Bearings for Radial Loads

Dimension Tables



ULTAGE Standard angular contact ball bearings (ceramic ball spec.)
5S-70U type

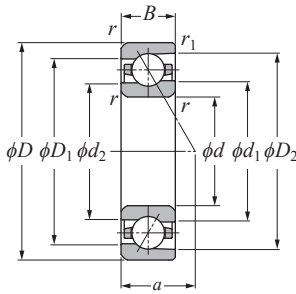

Contact angle 25° d 10–140 mm

Part number	Boundary dimensions					Basic load ratings				Allowable axial load		Allowable speed		Load center	Internal free space	Mass	Reference dimensions				Abutment and fillet dimensions					Part number
	mm					dynamic	static	dynamic	static	kN	kgf	grease lubrication	oil lubrication				mm				mm					
	d	D	B	$r_{s \min}^{1)}$	$r_{1s \min}^{1)}$	C_T	C_{Or}	C_T	C_{Or}	(static)							d_1	d_2	D_1	D_2	d_a min	D_a max	D_b max	r_{as} max	r_{1as} max	
5S-7000UAD	10	26	8	0.3	0.15	5.70	1.66	580	169	3.30	340	65 800	107 900	8.2	0.9	0.017	15.2	14.0	20.4	22.7	12.5	23.5	24.8	0.3	0.15	5S-7000UAD
5S-7001UAD	12	28	8	0.3	0.15	6.20	1.95	630	199	3.70	380	57 100	93 700	8.8	1.0	0.018	17.9	16.7	23.1	25.4	14.5	25.5	26.8	0.3	0.15	5S-7001UAD
5S-7002UAD	15	32	9	0.3	0.15	7.00	2.45	715	250	4.45	455	49 800	81 800	10.0	1.3	0.027	20.9	19.7	26.1	28.5	17.5	29.5	30.8	0.3	0.15	5S-7002UAD
5S-7003UAD	17	35	10	0.3	0.15	8.75	3.00	890	305	5.80	590	45 000	73 900	11.1	1.8	0.033	23.0	21.6	29.0	32.0	19.5	32.5	33.8	0.3	0.15	5S-7003UAD
5S-7004UAD	20	42	12	0.6	0.3	11.8	4.35	1 200	445	8.45	865	37 200	61 000	13.4	2.9	0.060	28.1	26.4	34.9	38.3	24.5	37.5	39.5	0.6	0.3	5S-7004UAD
5S-7005UAD	25	47	12	0.6	0.3	13.0	5.30	1 320	540	9.90	1 010	32 500	53 400	14.5	3.3	0.071	32.6	30.9	39.4	42.8	29.5	42.5	44.5	0.6	0.3	5S-7005UAD
5S-7006UAD	30	55	13	1	0.6	16.7	7.30	1 700	745	13.8	1 400	27 200	44 700	16.6	4.8	0.10	39.2	37.3	46.9	50.6	35.5	49.5	50.5	1	0.6	5S-7006UAD
5S-7007UAD	35	62	14	1	0.6	21.0	9.65	2 140	980	17.1	1 740	24 100	39 600	18.4	6.3	0.13	44.2	42.2	52.8	56.9	40.5	56.5	57.5	1	0.6	5S-7007UAD
5S-7008UAD	40	68	15	1	0.6	22.5	11.1	2 290	1 130	19.3	1 970	21 700	35 600	20.2	7.4	0.17	49.7	47.7	58.3	62.5	45.5	62.5	63.5	1	0.6	5S-7008UAD
5S-7009UAD	45	75	16	1	0.6	26.6	13.4	2 710	1 370	23.8	2 430	19 500	32 000	22.1	9.4	0.21	55.3	53.0	64.7	69.3	50.5	69.5	70.5	1	0.6	5S-7009UAD
5S-7010UAD	50	80	16	1	0.6	28.2	15.2	2 880	1 550	26.5	2 710	18 000	29 600	23.2	11	0.23	60.3	58.0	69.7	74.3	55.5	74.5	75.5	1	0.6	5S-7010UAD
5S-7011UAD	55	90	18	1.1	0.6	37.0	19.9	3 800	2 030	34.5	3 500	16 200	26 500	26.0	16	0.33	66.9	64.3	78.1	83.5	62	83	85.5	1	0.6	5S-7011UAD
5S-7012UAD	60	95	18	1.1	0.6	38.0	21.2	3 900	2 170	36.0	3 700	15 100	24 800	27.2	17	0.36	71.9	69.3	83.1	88.4	67	88	90.5	1	0.6	5S-7012UAD
5S-7013UAD	65	100	18	1.1	0.6	40.0	23.6	4 100	2 410	40.0	4 050	14 200	23 300	28.3	18	0.38	76.9	74.3	88.1	93.4	72	93	95.5	1	0.6	5S-7013UAD
5S-7014UAD	70	110	20	1.1	0.6	51.0	29.7	5 200	3 050	52.0	5 300	13 000	21 400	31.1	24	0.53	83.6	80.5	96.4	102.6	77	103	105.5	1	0.6	5S-7014UAD
5S-7015UAD	75	115	20	1.1	0.6	52.0	31.5	5 300	3 200	54.5	5 550	12 300	20 200	32.3	26	0.56	88.6	85.5	101.4	107.6	82	108	110.5	1	0.6	5S-7015UAD
5S-7016UAD	80	125	22	1.1	0.6	63.5	38.0	6 500	3 900	65.5	6 700	11 400	18 800	35.0	34	0.74	95.2	91.7	109.8	116.8	87	118	120.5	1	0.6	5S-7016UAD
5S-7017UAD	85	130	22	1.1	0.6	65.0	40.5	6 650	4 100	68.5	7 000	10 900	17 900	36.2	36	0.78	100.2	96.7	114.8	121.7	92	123	125.5	1	0.6	5S-7017UAD
5S-7018UAD	90	140	24	1.5	1	77.5	48.0	7 900	4 850	84.0	8 550	10 200	16 700	39.0	47	1.00	106.9	103.0	123.2	130.9	98.5	131.5	134.5	1.5	1	5S-7018UAD
5S-7019UAD	95	145	24	1.5	1	79.5	50.5	8 100	5 150	88.0	8 950	9 800	16 000	40.1	49	1.04	111.9	108.0	128.2	135.9	103.5	136.5	139.5	1.5	1	5S-7019UAD
5S-7020UAD	100	150	24	1.5	1	81.0	53.0	8 300	5 400	92.0	9 350	9 400	15 400	41.3	51	1.09	116.9	113.0	133.2	140.9	108.5	141.5	144.5	1.5	1	5S-7020UAD
5S-7021UAD	105	160	26	2	1	95.0	61.5	9 700	6 300	106	10 800	8 800	14 500	44.1	70	1.34	123.5	119.2	141.5	150.1	115	150	154.5	2	1	5S-7021UAD
5S-7022UAD	110	170	28	2	1	109	70.0	11 200	7 150	123	12 500	8 400	13 700	46.8	83	1.69	130.2	125.4	149.9	159.2	120	160	164.5	2	1	5S-7022UAD
5S-7024UAD	120	180	28	2	1	111	74.5	11 400	7 600	129	13 200	7 800	12 800	49.2	90	1.80	140.2	135.4	159.9	169.2	130	170	174.5	2	1	5S-7024UAD
5S-7026UAD	130	200	33	2	1	140	94.5	14 200	9 650	164	16 700	7 100	11 600	55.2	131	2.80	153.9	148.5	176.2	186.8	140	190	194.5	2	1	5S-7026UAD
5S-7028UAD	140	210	33	2	1	142	100	14 500	10 200	170	17 300	6 700	11 000	57.5	144	2.90	164.0	158.7	186.3	196.8	150	200	204.5	2	1	5S-7028UAD

1) Minimum allowable value for corner radius dimension r or r1.

Angular Contact Ball Bearings for Radial Loads

Dimension Tables



Dynamic equivalent radial load
 $P_r = X F_r + Y F_a$

e	Single row / Tandem		Back-to-back / Face-to-face					
	$F_a/F_r \leq e$	$F_a/F_r > e$	X	Y	X	Y		
0.68	1	0	0.41	0.87	1	0.92	0.67	1.41

Static equivalent radial load
 $P_{0r} = X_0 F_r + Y_0 F_a$

e	Single row / Tandem		Back-to-back / Face-to-face	
	X_0	Y_0	X_0	Y_0
0.5	0.5	0.38	1	0.76

When $P_{0r} < F_r$ with single-row or tandem arrangement, $P_{0r} = F_r$.

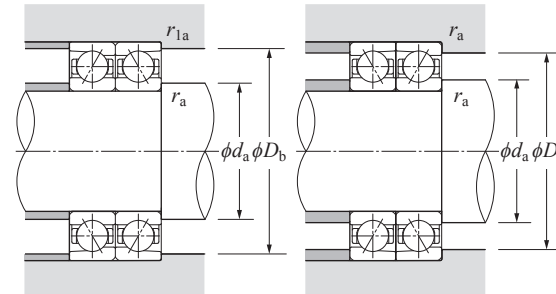

Back-to-back (DB)

Face-to-face (DF)

Main Spindle Bearings

Angular Contact Ball Bearings for Radial Loads

ULTAGE Standard angular contact ball bearings (ceramic ball spec.)
5S-70U type

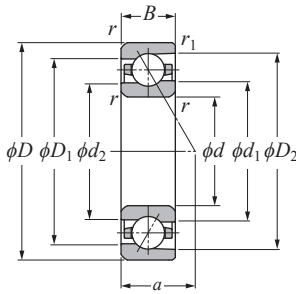

Contact angle 30° *d* 10–140 mm

Part number	Boundary dimensions					Basic load ratings				Allowable axial load		Allowable speed		Load center mm	Internal free space cm ³	Mass kg	Reference dimensions				Abutment and fillet dimensions					Part number
	mm					dynamic kN	static kgf	dynamic kN	static kgf	kN	kgf	grease lubrication	oil lubrication				mm				mm					
	<i>d</i>	<i>D</i>	<i>B</i>	<i>r_s</i> min ⁻¹	<i>r_{1s}</i> min ⁻¹												<i>C_r</i>	<i>C_{0r}</i>	<i>C_r</i>	<i>C_{0r}</i>	(static)			<i>d</i> ₁	<i>d</i> ₂	
5S-7000U	10	26	8	0.3	0.15	5.55	1.62	565	165	2.54	259	52 600	70 100	9.2	0.9	0.017	15.2	14.0	20.4	22.7	12.5	23.5	24.8	0.3	0.15	5S-7000U
5S-7001U	12	28	8	0.3	0.15	6.00	1.90	615	193	2.84	289	45 700	60 900	10.0	1.0	0.018	17.9	16.7	23.1	25.4	14.5	25.5	26.8	0.3	0.15	5S-7001U
5S-7002U	15	32	9	0.3	0.15	6.80	2.38	690	242	3.40	350	39 900	53 100	11.3	1.3	0.027	20.9	19.7	26.1	28.4	17.5	29.5	30.8	0.3	0.15	5S-7002U
5S-7003U	17	35	10	0.3	0.15	8.45	2.92	865	298	4.45	455	36 000	48 000	12.6	1.8	0.033	23.0	21.6	29.0	31.9	19.5	32.5	33.8	0.3	0.15	5S-7003U
5S-7004U	20	42	12	0.6	0.3	11.4	4.25	1 160	430	6.55	670	29 700	39 600	15.2	2.9	0.060	28.1	26.4	34.9	38.3	24.5	37.5	39.5	0.6	0.3	5S-7004U
5S-7005U	25	47	12	0.6	0.3	12.5	5.10	1 280	520	7.65	780	26 000	34 700	16.5	3.3	0.071	32.6	30.9	39.4	42.8	29.5	42.5	44.5	0.6	0.3	5S-7005U
5S-7006U	30	55	13	1	0.6	16.1	7.05	1 640	715	10.7	1 090	21 800	29 000	19.0	4.8	0.10	39.2	37.3	46.9	50.6	35.5	49.5	50.5	1	0.6	5S-7006U
5S-7007U	35	62	14	1	0.6	20.3	9.30	2 070	950	13.2	1 340	19 300	25 700	21.1	6.3	0.13	44.2	42.2	52.8	56.9	40.5	56.5	57.5	1	0.6	5S-7007U
5S-7008U	40	68	15	1	0.6	21.6	10.7	2 200	1 090	14.8	1 510	17 400	23 100	23.2	7.4	0.17	49.7	47.7	58.3	62.4	45.5	62.5	63.5	1	0.6	5S-7008U
5S-7009U	45	75	16	1	0.6	25.6	13.0	2 610	1 320	18.4	1 870	15 600	20 800	25.4	9.4	0.21	55.3	53.0	64.7	69.3	50.5	69.5	70.5	1	0.6	5S-7009U
5S-7010U	50	80	16	1	0.6	27.1	14.6	2 760	1 490	20.5	2 090	14 400	19 200	26.9	11	0.23	60.3	58.0	69.7	74.3	55.5	74.5	75.5	1	0.6	5S-7010U
5S-7011U	55	90	18	1.1	0.6	35.5	19.2	3 650	1 960	26.3	2 680	12 900	17 200	30.1	16	0.33	66.9	64.3	78.1	83.4	62	83	85.5	1	0.6	5S-7011U
5S-7012U	60	95	18	1.1	0.6	36.5	20.5	3 750	2 090	27.7	2 830	12 100	16 100	31.5	17	0.36	71.9	69.3	83.1	88.4	67	88	90.5	1	0.6	5S-7012U
5S-7013U	65	100	18	1.1	0.6	38.5	22.8	3 950	2 320	30.5	3 100	11 400	15 100	32.9	18	0.38	76.9	74.3	88.1	93.4	72	93	95.5	1	0.6	5S-7013U
5S-7014U	70	110	20	1.1	0.6	49.0	28.6	5 000	2 920	40.0	4 100	10 400	13 900	36.1	24	0.53	83.6	80.5	96.4	102.5	77	103	105.5	1	0.6	5S-7014U
5S-7015U	75	115	20	1.1	0.6	50.0	30.5	5 100	3 100	42.0	4 300	9 900	13 100	37.6	26	0.56	88.6	85.5	101.4	107.5	82	108	110.5	1	0.6	5S-7015U
5S-7016U	80	125	22	1.1	0.6	61.0	37.0	6 250	3 750	50.5	5 150	9 100	12 200	40.8	34	0.74	95.2	91.7	109.8	116.7	87	118	120.5	1	0.6	5S-7016U
5S-7017U	85	130	22	1.1	0.6	62.5	39.0	6 350	3 950	53.0	5 400	8 700	11 600	42.2	36	0.78	100.2	96.7	114.8	121.7	92	123	125.5	1	0.6	5S-7017U
5S-7018U	90	140	24	1.5	1	74.5	46.0	7 600	4 700	64.5	6 600	8 200	10 900	45.4	47	1.00	106.9	103.0	123.2	130.8	98.5	131.5	134.5	1.5	1	5S-7018U
5S-7019U	95	145	24	1.5	1	76.5	48.5	7 800	4 950	68.0	6 900	7 800	10 400	46.8	49	1.04	111.9	108.0	128.2	135.8	103.5	136.5	139.5	1.5	1	5S-7019U
5S-7020U	100	150	24	1.5	1	78.0	51.0	7 950	5 200	71.0	7 250	7 500	10 000	48.3	51	1.09	116.9	113.0	133.2	140.8	108.5	141.5	144.5	1.5	1	5S-7020U
5S-7021U	105	160	26	2	1	91.5	59.5	9 300	6 050	81.0	8 300	7 100	9 400	51.5	70	1.34	123.5	119.2	141.5	150.0	115	150	154.5	2	1	5S-7021U
5S-7022U	110	170	28	2	1	105	67.5	10 700	6 900	95.0	9 700	6 700	8 900	54.6	83	1.69	130.2	125.4	149.9	159.1	120	160	164.5	2	1	5S-7022U
5S-7024U	120	180	28	2	1	107	71.5	10 900	7 300	99.5	10 200	6 200	8 300	57.5	90	1.80	140.2	135.4	159.9	169.1	130	170	174.5	2	1	5S-7024U
5S-7026U	130	200	33	2	1	134	91.0	13 700	9 300	126	12 900	5 700	7 600	64.4	131	2.80	153.9	148.5	176.2	186.7	140	190	194.5	2	1	5S-7026U
5S-7028U	140	210	33	2	1	137	96.0	13 900	9 800	130	13 300	5 300	7 100	67.3	144	2.90	164.0	158.7	186.3	196.7	150	200	204.5	2	1	5S-7028U

1) Minimum allowable value for corner radius dimension *r* or *r₁*.

Angular Contact Ball Bearings for Radial Loads

Dynamic equivalent radial load
 $P_r = X F_r + Y F_a$

<i>e</i>	Single row / Tandem				Back-to-back / Face-to-face			
	$F_a/F_r \leq e$		$F_a/F_r > e$		$F_a/F_r \leq e$		$F_a/F_r > e$	
	<i>X</i>	<i>Y</i>	<i>X</i>	<i>Y</i>	<i>X</i>	<i>Y</i>	<i>X</i>	<i>Y</i>
0.8	1	0	0.39	0.76	1	0.78	0.63	1.24

Static equivalent radial load
 $P_{0r} = X_0 F_r + Y_0 F_a$

<i>e</i>	Single row / Tandem		Back-to-back / Face-to-face	
	<i>X</i> ₀	<i>Y</i> ₀	<i>X</i> ₀	<i>Y</i> ₀
	0.5	0.5	0.33	1

When $P_{0r} < F_r$ with single-row or tandem arrangement, $P_{0r} = F_r$.

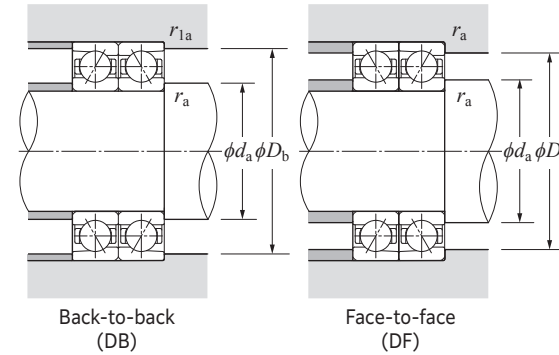

Back-to-back (DB)
Face-to-face (DF)

Main Spindle Bearings

Main Spindle Bearings

Angular Contact Ball Bearings for Radial Loads

ULTAGE High speed angular contact ball bearings (steel ball spec.)
2LA-HSE9U type

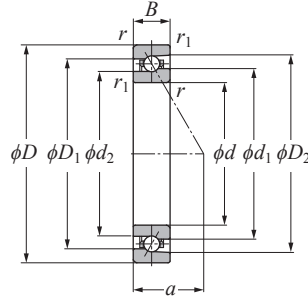

Contact angle 15° d 50–170 mm

Part number	Boundary dimensions						Basic load ratings				Allowable axial load		Factor f_0	Allowable speed		Load center mm a	Internal free space cm ²	Mass kg	Reference dimensions				Abutment and fillet dimensions					
	mm						dynamic kN	static kgf	dynamic kN	static kgf	(static) kN	grease lubrication min ⁻¹		oil lubrication min ⁻¹	mm				mm									
	d	D	B	$r_{s \min}^1$	$r_{ls \min}^1$	C_{Or}	C_r	C_{Or}	C_r	C_{Or}					d_1				d_2	D_1	D_2	$d_a \min$	$d_b \min$	$D_a \max$	$D_b \max$	$r_{as \max}$	$r_{las \max}$	
2LA-HSE910UC	50	72	12	0.6	0.3	12.1	8.10	1 240	830	11.8	1 210	10.9	21 800	34 600	14.2	6.0	0.13	57.6	56.6	64.4	66.8	54.5	52.5	67.5	69.5	0.6	0.3	
2LA-HSE911UC	55	80	13	1	0.6	15.1	10.1	1 540	1 030	14.8	1 510	10.8	19 700	31 300	15.6	7.7	0.18	63.6	62.4	71.4	74.1	60.5	59.5	74.5	75.5	1	0.6	
2LA-HSE912UC	60	85	13	1	0.6	15.7	11.1	1 600	1 130	16.2	1 660	10.9	18 300	29 100	16.3	8.3	0.20	68.6	67.4	76.4	79.1	65.5	64.5	79.5	80.5	1	0.6	
2LA-HSE913UC	65	90	13	1	0.6	15.8	11.6	1 620	1 180	17.0	1 740	11.0	17 200	27 200	17.0	8.9	0.21	73.6	72.4	81.4	84.1	70.5	69.5	84.5	85.5	1	0.6	
2LA-HSE914UC	70	100	16	1	0.6	23.2	16.5	2 370	1 680	24.2	2 470	10.9	15 600	24 800	19.5	14	0.34	80.1	78.6	89.8	93.2	75.5	74.5	94.5	95.5	1	0.6	
2LA-HSE915UC	75	105	16	1	0.6	24.1	18.0	2 460	1 830	26.3	2 690	10.9	14 800	23 400	20.1	15	0.36	85.1	83.6	94.8	98.2	80.5	79.5	99.5	100.5	1	0.6	
2LA-HSE916UC	80	110	16	1	0.6	24.4	18.8	2 490	1 910	27.5	2 810	11.0	14 000	22 200	20.8	16	0.38	90.1	88.6	99.8	103.2	85.5	84.5	104.5	105.5	1	0.6	
2LA-HSE917UC	85	120	18	1.1	0.6	33.0	24.8	3 350	2 520	36.0	3 700	10.9	13 000	20 600	22.8	22	0.54	96.8	94.9	108.2	112.3	92	89.5	113	115.5	1	0.6	
2LA-HSE918UC	90	125	18	1.1	0.6	34.5	26.8	3 500	2 740	39.0	4 000	10.9	12 400	19 600	23.5	23	0.56	101.8	99.9	113.2	117.3	97	94.5	118	120.5	1	0.6	
2LA-HSE919UC	95	130	18	1.1	0.6	35.0	27.9	3 550	2 850	40.5	4 150	11.0	11 800	18 800	24.2	24	0.59	106.8	104.9	118.2	122.3	102	99.5	123	125.5	1	0.6	
2LA-HSE920UC	100	140	20	1.1	0.6	40.5	32.5	4 100	3 350	48.0	4 900	11.0	11 100	17 600	26.2	32	0.82	113.8	111.7	126.2	130.7	107	104.5	133	135.5	1	0.6	
2LA-HSE921UC	105	145	20	1.1	0.6	41.0	34.0	4 150	3 450	50.0	5 100	11.0	10 600	16 900	26.9	33	0.85	118.8	116.7	131.2	135.7	112	109.5	138	140.5	1	0.6	
2LA-HSE922UC	110	150	20	1.1	0.6	41.5	35.5	4 200	3 600	51.0	5 250	11.1	10 200	16 200	27.5	35	0.88	123.8	121.7	136.2	140.7	117	114.5	143	145.5	1	0.6	
2LA-HSE924UC	120	165	22	1.1	0.6	53.0	45.0	5 400	4 600	66.0	6 750	11.0	9 300	14 800	30.2	47	1.20	135.4	133.0	149.6	154.8	127	124.5	158	160.5	1	0.6	
2LA-HSE926UC	130	180	24	1.5	1	65.5	56.0	6 700	5 700	81.5	8 350	11.0	8 600	13 600	32.9	62	1.56	146.9	144.2	163.1	168.9	138.5	135.5	171.5	174.5	1.5	1	
2LA-HSE928UC	140	190	24	1.5	1	66.0	58.0	6 750	5 950	85.0	8 700	11.0	8 100	12 800	34.3	66	1.66	156.9	154.2	173.1	178.9	148.5	145.5	181.5	184.5	1.5	1	
2LA-HSE930UC	150	210	28	2	1	88.0	77.0	8 950	7 850	112	11 500	10.9	7 400	11 700	38.3	99	2.58	170.5	167.3	189.5	196.4	160	155.5	200	204.5	2	1	
2LA-HSE932UC	160	220	28	2	1	89.0	80.5	9 050	8 200	117	12 000	11.0	7 000	11 100	39.6	105	2.71	180.5	177.3	199.5	206.3	170	165.5	210	214.5	2	1	
2LA-HSE934UC	170	230	28	2	1	89.5	83.5	9 150	8 500	122	12 500	11.1	6 700	10 600	41.0	111	2.84	190.5	187.3	209.5	216.3	180	175.5	220	224.5	2	1	

1) Minimum allowable value for corner radius dimension r or r_1 .

Angular Contact Ball Bearings for Radial Loads



Dynamic equivalent radial load
 $P_r = X F_r + Y F_a$

$i \cdot f_0 \cdot F_a$	C_{Or}	e	Single row / Tandem				Back-to-back / Face-to-face			
			$F_a/F_r \leq e$		$F_a/F_r > e$		$F_a/F_r \leq e$		$F_a/F_r > e$	
			X	Y	X	Y	X	Y	X	Y
0.178	0.35				1.57		1.76		2.56	
0.357	0.36				1.53		1.71		2.48	
0.714	0.38				1.46		1.64		2.38	
1.07	0.4				1.42		1.59		2.31	
1.43	0.41	1	0	0.44	1.38	1	1.55	0.72	2.25	
2.14	0.43				1.33		1.49		2.16	
3.57	0.44				1.25		1.4		2.03	
5.35	0.47				1.18		1.32		1.92	
7.14	0.49				1.13		1.26		1.83	

Static equivalent radial load
 $P_{Or} = X_0 F_r + Y_0 F_a$

Single row / Tandem		Back-to-back / Face-to-face	
X_0	Y_0	X_0	Y_0
0.52	0.54	1.04	1.08

When $P_{Or} < F_r$ with single-row or tandem arrangement, $P_{Or} = F_r$.

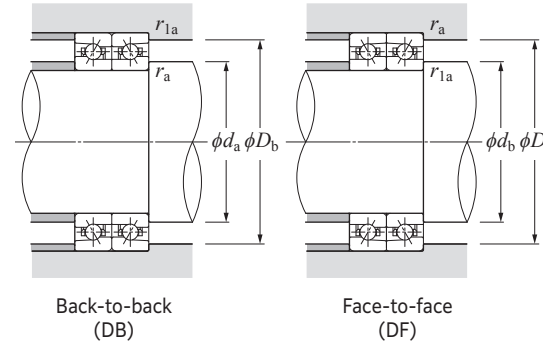

Angular Contact Ball Bearings for Radial Loads

Dimension Tables



ULTAGE High speed angular contact ball bearings (steel ball spec.)
2LA-HSE9U type

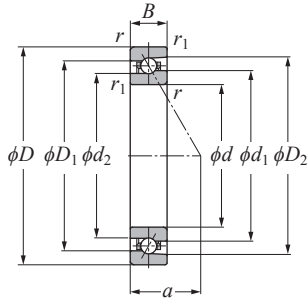

Contact angle 20° d 50–170 mm

Part number	Boundary dimensions					Basic load ratings				Allowable axial load		Allowable speed		Load center mm	Internal free space cm ³	Mass kg	Reference dimensions				Abutment and fillet dimensions					
	mm					dynamic	static	dynamic	static	(static)	grease lubrication	oil lubrication	mm				mm									
	d	D	B	$r_s \min^1$	$r_{1s} \min^1$	C_r	C_{0r}	C_r	C_{0r}				kN				kgf	kN	kgf	d_1	d_2	D_1	D_2	d_a min	d_b min	D_a max
2LA-HSE910U	50	72	12	0.6	0.3	11.8	7.95	1 210	810	13.2	1 350	23 100	37 200	17.2	6.0	0.13	57.6	56.6	64.4	66.8	54.5	52.5	67.5	69.5	0.6	0.3
2LA-HSE911U	55	80	13	1	0.6	14.7	9.90	1 500	1 010	16.5	1 690	20 800	33 600	18.9	7.7	0.18	63.6	62.4	71.4	74.1	60.5	59.5	74.5	75.5	1	0.6
2LA-HSE912U	60	85	13	1	0.6	15.3	10.8	1 560	1 100	18.1	1 850	19 400	31 300	19.8	8.3	0.20	68.6	67.4	76.4	79.1	65.5	64.5	79.5	80.5	1	0.6
2LA-HSE913U	65	90	13	1	0.6	15.4	11.3	1 570	1 150	18.9	1 930	18 200	29 300	20.7	8.9	0.21	73.6	72.4	81.4	84.0	70.5	69.5	84.5	85.5	1	0.6
2LA-HSE914U	70	100	16	1	0.6	22.6	16.1	2 310	1 640	26.9	2 750	16 600	26 700	23.6	14	0.34	80.1	78.6	89.8	93.2	75.5	74.5	94.5	95.5	1	0.6
2LA-HSE915U	75	105	16	1	0.6	23.5	17.5	2 390	1 790	29.4	3 000	15 600	25 200	24.5	15	0.36	85.1	83.6	94.8	98.2	80.5	79.5	99.5	100.5	1	0.6
2LA-HSE916U	80	110	16	1	0.6	23.7	18.3	2 420	1 870	30.0	3 100	14 800	23 900	25.4	16	0.38	90.1	88.6	99.8	103.2	85.5	84.5	104.5	105.5	1	0.6
2LA-HSE917U	85	120	18	1.1	0.6	32.0	24.2	3 300	2 470	40.0	4 100	13 700	22 100	27.8	22	0.54	96.8	94.9	108.2	112.3	92	89.5	113	115.5	1	0.6
2LA-HSE918U	90	125	18	1.1	0.6	33.5	26.2	3 400	2 670	43.5	4 450	13 100	21 100	28.7	23	0.56	101.8	99.9	113.2	117.3	97	94.5	118	120.5	1	0.6
2LA-HSE919U	95	130	18	1.1	0.6	34.0	27.3	3 450	2 780	45.5	4 650	12 500	20 200	29.6	24	0.59	106.8	104.9	118.2	122.3	102	99.5	123	125.5	1	0.6
2LA-HSE920U	100	140	20	1.1	0.6	39.5	32.0	4 000	3 250	53.0	5 450	11 700	18 900	32.0	32	0.82	113.8	111.7	126.2	130.6	107	104.5	133	135.5	1	0.6
2LA-HSE921U	105	145	20	1.1	0.6	40.0	33.0	4 050	3 400	55.0	5 650	11 300	18 200	32.9	33	0.85	118.8	116.7	131.2	135.6	112	109.5	138	140.5	1	0.6
2LA-HSE922U	110	150	20	1.1	0.6	40.0	34.5	4 100	3 500	57.0	5 850	10 800	17 500	33.8	35	0.88	123.8	121.7	136.2	140.6	117	114.5	143	145.5	1	0.6
2LA-HSE924U	120	165	22	1.1	0.6	51.5	44.0	5 250	4 500	74.0	7 550	9 900	15 900	37.1	47	1.20	135.4	133.0	149.6	154.7	127	124.5	158	160.5	1	0.6
2LA-HSE926U	130	180	24	1.5	1	64.0	54.5	6 500	5 550	91.0	9 300	9 100	14 600	40.4	62	1.56	146.9	144.2	163.1	168.9	138.5	135.5	171.5	174.5	1.5	1
2LA-HSE928U	140	190	24	1.5	1	64.5	57.0	6 550	5 800	95.0	9 700	8 500	13 800	42.2	66	1.66	156.9	154.2	173.1	178.8	148.5	145.5	181.5	184.5	1.5	1
2LA-HSE930U	150	210	28	2	1	86.0	75.5	8 750	7 700	125	12 800	7 800	12 600	47.0	99	2.58	170.5	167.3	189.5	196.3	160	155.5	200	204.5	2	1
2LA-HSE932U	160	220	28	2	1	86.5	78.5	8 850	8 000	131	13 400	7 400	11 900	48.8	105	2.71	180.5	177.3	199.5	206.3	170	165.5	210	214.5	2	1
2LA-HSE934U	170	230	28	2	1	87.5	81.5	8 900	8 300	136	13 900	7 000	11 300	50.6	111	2.84	190.5	187.3	209.5	216.3	180	175.5	220	224.5	2	1

1) Minimum allowable value for corner radius dimension r or r_1 .

Angular Contact Ball Bearings for Radial Loads

Dimension Tables



Dynamic equivalent radial load
 $P_r = X F_r + Y F_a$

e	Single row / Tandem				Back-to-back / Face-to-face			
	$F_a/F_r \leq e$		$F_a/F_r > e$		$F_a/F_r \leq e$		$F_a/F_r > e$	
	X	Y	X	Y	X	Y	X	Y
0.57	1	0	0.43	1	1	1.09	0.7	1.63

Static equivalent radial load
 $P_{0r} = X_0 F_r + Y_0 F_a$

Single row / Tandem		Back-to-back / Face-to-face	
X_0	Y_0	X_0	Y_0
0.5	0.42	1	0.84

When $P_{0r} < F_r$ with single-row or tandem arrangement, $P_{0r} = F_r$.

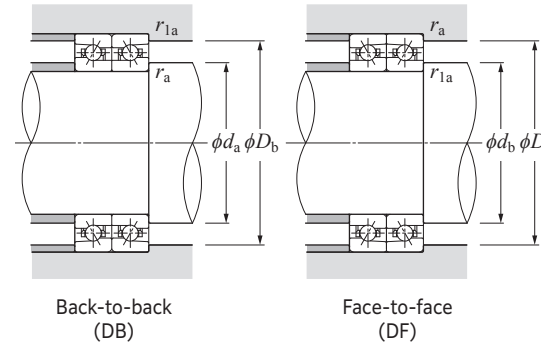

Angular Contact Ball Bearings for Radial Loads

ULTAGE High speed angular contact ball bearings (steel ball spec.)
2LA-HSE9U type

Dimension Tables

NTN

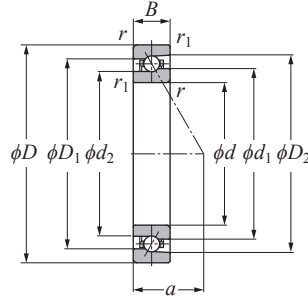

Contact angle 25° d 50–170 mm

Part number	Boundary dimensions					Basic load ratings				Allowable axial load		Allowable speed		Load center mm	Internal free space cm ³	Mass kg	Reference dimensions				Abutment and fillet dimensions					
	mm					dynamic kN	static kN	dynamic kgf	static kgf	(static) kN	kgf	grease lubrication min ⁻¹	oil lubrication min ⁻¹				mm				mm					
	d	D	B	$r_s \min^1$	$r_{1s} \min^1$	C_r	C_{Or}	C_r	C_{Or}								d_1	d_2	D_1	D_2	$d_a \min$	$d_b \min$	$D_a \max$	$D_b \max$	$r_{as} \max$	$r_{1as} \max$
2LA-HSE910UAD	50	72	12	0.6	0.3	11.4	7.70	1 170	785	14.8	1 510	20 500	32 100	20.3	6.0	0.13	57.6	56.6	64.4	66.7	54.5	52.5	67.5	69.5	0.6	0.3
2LA-HSE911UAD	55	80	13	1	0.6	14.3	9.60	1 450	980	18.4	1 880	18 500	29 000	22.4	7.7	0.18	63.6	62.4	71.4	74.1	60.5	59.5	74.5	75.5	1	0.6
2LA-HSE912UAD	60	85	13	1	0.6	14.8	10.5	1 510	1 070	20.2	2 060	17 200	27 000	23.5	8.3	0.20	68.6	67.4	76.4	79.0	65.5	64.5	79.5	80.5	1	0.6
2LA-HSE913UAD	65	90	13	1	0.6	14.9	11.0	1 520	1 120	21.1	2 160	16 100	25 300	24.7	8.9	0.21	73.6	72.4	81.4	84.0	70.5	69.5	84.5	85.5	1	0.6
2LA-HSE914UAD	70	100	16	1	0.6	21.9	15.6	2 230	1 590	29.9	3 050	14 700	23 000	28.0	14	0.34	80.1	78.6	89.8	93.2	75.5	74.5	94.5	95.5	1	0.6
2LA-HSE915UAD	75	105	16	1	0.6	22.7	17.0	2 310	1 730	32.0	3 300	13 900	21 700	29.1	15	0.36	85.1	83.6	94.8	98.2	80.5	79.5	99.5	100.5	1	0.6
2LA-HSE916UAD	80	110	16	1	0.6	23.0	17.7	2 340	1 810	33.5	3 450	13 200	20 600	30.3	16	0.38	90.1	88.6	99.8	103.2	85.5	84.5	104.5	105.5	1	0.6
2LA-HSE917UAD	85	120	18	1.1	0.6	31.0	23.4	3 150	2 390	45.0	4 600	12 200	19 100	33.1	22	0.54	96.8	94.9	108.2	112.3	92	89.5	113	115.5	1	0.6
2LA-HSE918UAD	90	125	18	1.1	0.6	32.5	25.4	3 300	2 590	48.5	4 950	11 600	18 200	34.2	23	0.56	101.8	99.9	113.2	117.3	97	94.5	118	120.5	1	0.6
2LA-HSE919UAD	95	130	18	1.1	0.6	32.5	26.4	3 350	2 690	50.5	5 200	11 100	17 400	35.4	24	0.59	106.8	104.9	118.2	122.3	102	99.5	123	125.5	1	0.6
2LA-HSE920UAD	100	140	20	1.1	0.6	38.0	31.0	3 850	3 150	59.0	6 050	10 400	16 300	38.2	32	0.82	113.8	111.7	126.2	130.6	107	104.5	133	135.5	1	0.6
2LA-HSE921UAD	105	145	20	1.1	0.6	38.5	32.0	3 900	3 300	61.5	6 300	10 000	15 700	39.3	33	0.85	118.8	116.7	131.2	135.6	112	109.5	138	140.5	1	0.6
2LA-HSE922UAD	110	150	20	1.1	0.6	39.0	33.5	3 950	3 400	64.0	6 550	9 600	15 100	40.5	35	0.88	123.8	121.7	136.2	140.6	117	114.5	143	145.5	1	0.6
2LA-HSE924UAD	120	165	22	1.1	0.6	50.0	42.5	5 100	4 350	82.0	8 400	8 800	13 700	44.4	47	1.20	135.4	133.0	149.6	154.7	127	124.5	158	160.5	1	0.6
2LA-HSE926UAD	130	180	24	1.5	1	61.5	53.0	6 300	5 400	101	10 400	8 100	12 600	48.4	62	1.56	146.9	144.2	163.1	168.8	138.5	135.5	171.5	174.5	1.5	1
2LA-HSE928UAD	140	190	24	1.5	1	62.0	55.0	6 350	5 600	105	10 800	7 600	11 900	50.7	66	1.66	156.9	154.2	173.1	178.8	148.5	145.5	181.5	184.5	1.5	1
2LA-HSE930UAD	150	210	28	2	1	83.0	73.0	8 450	7 450	140	14 300	6 900	10 900	56.3	99	2.58	170.5	167.3	189.5	196.3	160	155.5	200	204.5	2	1
2LA-HSE932UAD	160	220	28	2	1	83.5	76.0	8 550	7 750	146	14 900	6 600	10 300	58.6	105	2.71	180.5	177.3	199.5	206.3	170	165.5	210	214.5	2	1
2LA-HSE934UAD	170	230	28	2	1	84.5	79.0	8 600	8 050	152	15 500	6 200	9 800	60.9	111	2.84	190.5	187.3	209.5	216.3	180	175.5	220	224.5	2	1

1) Minimum allowable value for corner radius dimension r or r_1 .

Angular Contact Ball Bearings for Radial Loads

Dynamic equivalent radial load
 $P_r = XF_r + YF_a$

e	Single row / Tandem				Back-to-back / Face-to-face			
	$F_a/F_r \leq e$		$F_a/F_r > e$		$F_a/F_r \leq e$		$F_a/F_r > e$	
	X	Y	X	Y	X	Y	X	Y
0.68	1	0	0.41	0.87	1	0.92	0.67	1.41

Static equivalent radial load
 $P_{0r} = X_0 F_r + Y_0 F_a$

Single row / Tandem		Back-to-back / Face-to-face	
X_0	Y_0	X_0	Y_0
0.5	0.38	1	0.76

When $P_{0r} < F_r$ with single-row or tandem arrangement, $P_{0r} = F_r$.

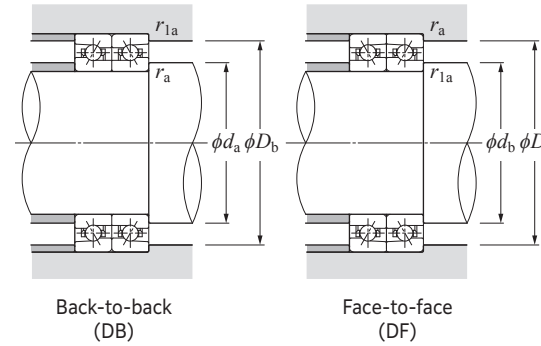

Main Spindle Bearings

Angular Contact Ball Bearings for Radial Loads

ULTAGE High speed angular contact ball bearings (steel ball spec.)
2LA-HSE0 type

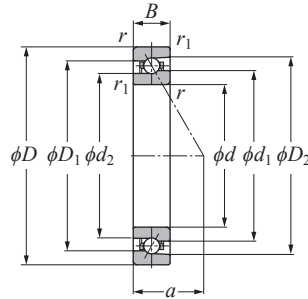

Contact angle 15° d 50–170 mm

Part number	Boundary dimensions						Basic load ratings				Allowable axial load		Factor f_0	Allowable speed		Load center mm a	Internal free space cm^2	Mass kg	Reference dimensions				Abutment and fillet dimensions					
	mm						dynamic kN	static kgf	dynamic kgf	static kN	(static) kN	grease lubrication		oil lubrication	mm				mm									
	d	D	B	r_s	r_{1s}	$r_{1s \min}^{1)}$	C_r	C_{0r}	C_r	C_{0r}					f_0				f_0	d_1	d_2	D_1	D_2	d_a	d_b	D_a	D_b	r_{as}
2LA-HSE010C	50	80	16	1	0.6	17.6	11.4	1 800	1 160	16.7	1 700	10.4	20 500	32 500	16.8	12	0.26	60.1	58.6	69.9	73.3	55.5	54.5	74.5	75.5	1	0.6	
2LA-HSE011C	55	90	18	1.1	0.6	19.1	13.6	1 950	1 380	19.9	2 030	10.6	18 300	29 100	18.8	16	0.40	67.6	66.2	77.4	80.8	62	59.5	83	85.5	1	0.6	
2LA-HSE012C	60	95	18	1.1	0.6	20.0	15.0	2 040	1 530	22.0	2 240	10.7	17 200	27 200	19.5	17	0.42	72.6	71.2	82.4	85.8	67	64.5	88	90.5	1	0.6	
2LA-HSE013C	65	100	18	1.1	0.6	20.3	15.8	2 070	1 610	23.2	2 360	10.8	16 100	25 600	20.1	18	0.45	77.6	76.2	87.4	90.8	72	69.5	93	95.5	1	0.6	
2LA-HSE014C	70	110	20	1.1	0.6	24.9	19.9	2 540	2 030	29.2	2 980	10.8	14 800	23 400	22.2	24	0.64	84.8	83.0	95.2	99.1	77	74.5	103	105.5	1	0.6	
2LA-HSE015C	75	115	20	1.1	0.6	26.5	22.4	2 700	2 290	33.0	3 350	10.9	14 000	22 200	22.8	25	0.68	89.8	88.0	100.2	104.1	82	79.5	108	110.5	1	0.6	
2LA-HSE016C	80	125	22	1.1	0.6	30.5	25.7	3 100	2 620	38.0	3 850	10.9	13 000	20 600	24.8	34	0.91	96.8	94.9	108.2	112.5	87	84.5	118	120.5	1	0.6	
2LA-HSE017C	85	130	22	1.1	0.6	30.5	26.8	3 150	2 740	39.5	4 000	10.9	12 400	19 600	25.5	35	0.96	101.8	99.9	113.2	117.5	92	89.5	123	125.5	1	0.6	
2LA-HSE018C	90	140	24	1.5	1	35.5	31.5	3 650	3 200	46.0	4 700	10.9	11 600	18 300	27.5	45	1.25	108.8	106.7	121.2	125.8	98.5	95.5	131.5	134.5	1.5	1	
2LA-HSE019C	95	145	24	1.5	1	36.0	32.5	3 700	3 350	48.0	4 900	11.0	11 100	17 600	28.2	47	1.30	113.8	111.7	126.2	130.8	103.5	100.5	136.5	139.5	1.5	1	
2LA-HSE020C	100	150	24	1.5	1	37.5	35.0	3 800	3 600	51.5	5 250	11.0	10 600	16 900	28.9	49	1.36	118.8	116.7	131.2	135.8	108.5	105.5	141.5	144.5	1.5	1	
2LA-HSE021C	105	160	26	2	1	43.0	40.5	4 350	4 150	60.0	6 100	11.0	10 000	15 900	30.9	61	1.73	125.8	123.6	139.2	144.1	115	110.5	150	154.5	2	1	
2LA-HSE022C	110	170	28	2	1	53.0	49.5	5 400	5 000	72.5	7 400	10.9	9 500	15 100	32.9	77	2.13	132.4	129.8	147.6	153.3	120	115.5	160	164.5	2	1	
2LA-HSE024C	120	180	28	2	1	53.5	51.5	5 450	5 250	75.5	7 700	11.0	8 900	14 100	34.2	82	2.28	142.4	139.8	157.6	163.3	130	125.5	170	174.5	2	1	
2LA-HSE026C	130	200	33	2	1	76.5	71.0	7 800	7 250	104	10 600	10.8	8 100	12 800	38.8	130	3.40	155.5	152.3	174.5	181.6	140	135.5	190	194.5	2	1	
2LA-HSE028C	140	210	33	2	1	79.5	77.0	8 100	7 850	113	11 500	10.9	7 600	12 100	40.1	129	3.68	165.5	162.4	184.5	191.5	150	145.5	200	204.5	2	1	
2LA-HSE030C	150	225	35	2.1	1.1	81.5	83.0	8 300	8 450	122	12 400	11.0	7 100	11 300	42.8	163	4.46	178.0	174.8	197.0	204.1	162	157	213	218	2	1	
2LA-HSE032C	160	240	38	2.1	1.1	95.5	97.0	9 750	9 850	142	14 500	11.0	6 700	10 600	46.0	206	5.46	189.5	186.0	210.5	218.2	172	167	228	233	2	1	
2LA-HSE034C	170	260	42	2.1	1.1	110	111	11 200	11 300	163	16 700	10.9	6 200	9 800	50.0	272	7.37	203.6	199.8	226.4	234.9	182	177	248	253	2	1	

1) Minimum allowable value for corner radius dimension r or r_1 .

Angular Contact Ball Bearings for Radial Loads

Dynamic equivalent radial load
 $P_r = X F_r + Y F_a$

$i f_0 F_a$	C_{0r}	e	Single row / Tandem				Back-to-back / Face-to-face				
			$F_a/F_r \leq e$		$F_a/F_r > e$		$F_a/F_r \leq e$		$F_a/F_r > e$		
			X	Y	X	Y	X	Y	X	Y	
0.178	0.35				1.57	1.76					2.56
0.357	0.36				1.53	1.71					2.48
0.714	0.38				1.46	1.64					2.38
1.07	0.4				1.42	1.59					2.31
1.43	0.41	1	0	0.44	1.38	1	1.55	0.72			2.25
2.14	0.43				1.33	1.49					2.16
3.57	0.44				1.25	1.4					2.03
5.35	0.47				1.18	1.32					1.92
7.14	0.49				1.13	1.26					1.83

Static equivalent radial load
 $P_{0r} = X_0 F_r + Y_0 F_a$

Single row / Tandem		Back-to-back / Face-to-face	
X_0	Y_0	X_0	Y_0
0.52	0.54	1.04	1.08

When $P_{0r} < F_r$ with single-row or tandem arrangement, $P_{0r} = F_r$.

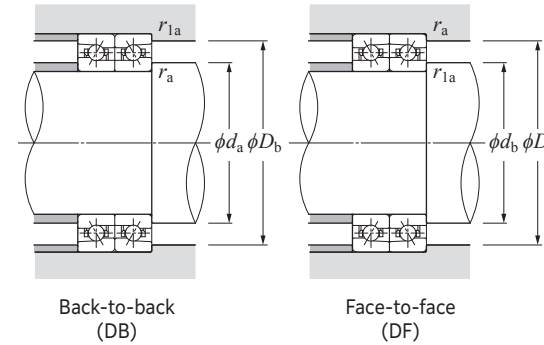

Main Spindle Bearings

Main Spindle Bearings

Angular Contact Ball Bearings for Radial Loads

ULTAGE High speed angular contact ball bearings (steel ball spec.)
2LA-HSE0 type

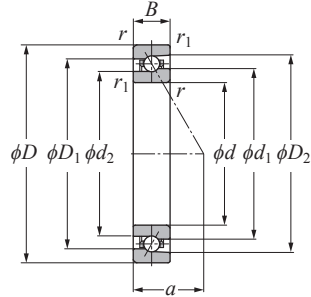

Contact angle 20° d 50–170 mm

Part number	Boundary dimensions					Basic load ratings				Allowable axial load		Allowable speed		Load center mm	Internal free space cm ³	Mass kg	Reference dimensions				Abutment and fillet dimensions					
	mm					dynamic kN	static kN	dynamic kgf	static kgf	(static)		grease lubrication	oil lubrication				mm				mm					
	d	D	B	$r_{s \min}^{1)}$	$r_{is \min}^{1)}$	C_r	C_{0r}	C_r	C_{0r}	(static)	(static)						d_1	d_2	D_1	D_2	d_a min	d_b min	D_a max	D_b max	r_{as} max	r_{1as} max
2LA-HSE010	50	80	16	1	0.6	17.2	11.2	1 750	1 140	18.7	1 900	21 600	34 900	19.9	12	0.26	60.1	58.6	69.9	73.2	55.5	54.5	74.5	75.5	1	0.6
2LA-HSE011	55	90	18	1.1	0.6	18.7	13.3	1 900	1 350	22.2	2 260	19 400	31 300	22.3	16	0.40	67.6	66.2	77.4	80.8	62	59.5	83	85.5	1	0.6
2LA-HSE012	60	95	18	1.1	0.6	19.5	14.7	1 990	1 490	24.6	2 500	18 200	29 300	23.2	17	0.42	72.6	71.2	82.4	85.8	67	64.5	88	90.5	1	0.6
2LA-HSE013	65	100	18	1.1	0.6	19.8	15.4	2 020	1 570	25.9	2 640	17 100	27 500	24.1	18	0.45	77.6	76.2	87.4	90.8	72	69.5	93	95.5	1	0.6
2LA-HSE014	70	110	20	1.1	0.6	24.2	19.4	2 470	1 980	32.5	3 300	15 600	25 200	26.5	24	0.64	84.8	83.0	95.2	99.1	77	74.5	103	105.5	1	0.6
2LA-HSE015	75	115	20	1.1	0.6	25.8	21.9	2 630	2 230	36.5	3 750	14 800	23 900	27.4	25	0.68	89.8	88.0	100.2	104.1	82	79.5	108	110.5	1	0.6
2LA-HSE016	80	125	22	1.1	0.6	29.6	25.1	3 000	2 560	42.0	4 300	13 700	22 100	29.8	34	0.91	96.8	94.9	108.2	112.5	87	84.5	118	120.5	1	0.6
2LA-HSE017	85	130	22	1.1	0.6	30.0	26.2	3 050	2 670	44.0	4 500	13 100	21 100	30.7	35	0.96	101.8	99.9	113.2	117.4	92	89.5	123	125.5	1	0.6
2LA-HSE018	90	140	24	1.5	1	34.5	30.5	3 550	3 150	51.5	5 250	12 200	19 700	33.1	45	1.25	108.8	106.7	121.2	125.8	98.5	95.5	131.5	134.5	1.5	1
2LA-HSE019	95	145	24	1.5	1	35.0	32.0	3 600	3 250	53.5	5 450	11 700	18 900	34.0	47	1.30	113.8	111.7	126.2	130.8	103.5	100.5	136.5	139.5	1.5	1
2LA-HSE020	100	150	24	1.5	1	36.5	34.5	3 700	3 500	57.5	5 850	11 300	18 200	34.9	49	1.36	118.8	116.7	131.2	135.8	108.5	105.5	141.5	144.5	1.5	1
2LA-HSE021	105	160	26	2	1	42.0	39.5	4 250	4 050	66.5	6 800	10 600	17 100	37.3	61	1.73	125.8	123.6	139.2	144.1	115	110.5	150	154.5	2	1
2LA-HSE022	110	170	28	2	1	51.5	48.0	5 300	4 900	80.5	8 200	10 000	16 200	39.7	77	2.13	132.4	129.8	147.6	153.2	120	115.5	160	164.5	2	1
2LA-HSE024	120	180	28	2	1	52.0	50.0	5 300	5 100	84.0	8 600	9 400	15 100	41.5	82	2.28	142.4	139.8	157.6	163.2	130	125.5	170	174.5	2	1
2LA-HSE026	130	200	33	2	1	74.5	69.5	7 600	7 100	116	11 900	8 500	13 800	46.8	130	3.40	155.5	152.3	174.5	181.5	140	135.5	190	194.5	2	1
2LA-HSE028	140	210	33	2	1	77.5	75.0	7 900	7 650	126	12 800	8 000	13 000	48.6	129	3.68	165.5	162.4	184.5	191.5	150	145.5	200	204.5	2	1
2LA-HSE030	150	225	35	2.1	1.1	79.5	81.0	8 100	8 250	136	13 900	7 500	12 100	51.9	163	4.46	178.0	174.8	197.0	204.0	162	157	213	218	2	1
2LA-HSE032	160	240	38	2.1	1.1	93.0	94.5	9 500	9 650	159	16 200	7 000	11 300	55.7	206	5.46	189.5	186.0	210.5	218.2	172	167	228	233	2	1
2LA-HSE034	170	260	42	2.1	1.1	107	108	10 900	11 100	182	18 600	6 500	10 600	60.4	272	7.37	203.6	199.8	226.4	234.9	182	177	248	253	2	1

1) Minimum allowable value for corner radius dimension r or r_1 .

Angular Contact Ball Bearings for Radial Loads

Dynamic equivalent radial load
 $P_r = X F_r + Y F_a$

e	Single row / Tandem				Back-to-back / Face-to-face			
	$F_a/F_r \leq e$		$F_a/F_r > e$		$F_a/F_r \leq e$		$F_a/F_r > e$	
	X	Y	X	Y	X	Y	X	Y
0.57	1	0	0.43	1	1	1.09	0.7	1.63

Static equivalent radial load
 $P_{0r} = X_0 F_r + Y_0 F_a$

Single row / Tandem		Back-to-back / Face-to-face	
X_0	Y_0	X_0	Y_0
0.5	0.42	1	0.84

When $P_{0r} < F_r$ with single-row or tandem arrangement, $P_{0r} = F_r$.

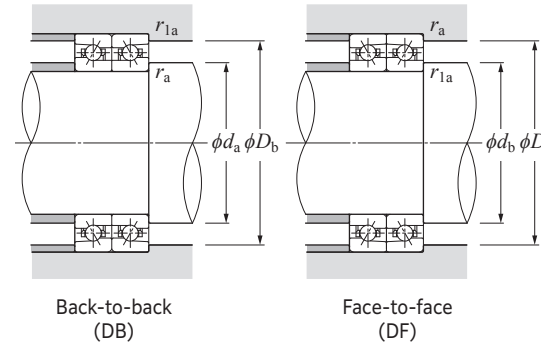

Main Spindle Bearings

Angular Contact Ball Bearings for Radial Loads

ULTAGE High speed angular contact ball bearings (steel ball spec.)
2LA-HSE0 type

Dimension Tables

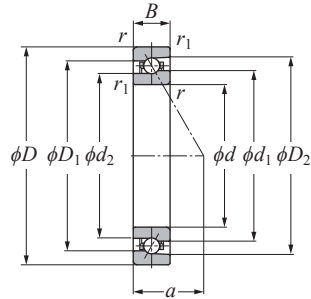

Contact angle 25° d 50–170 mm

Part number	Boundary dimensions					Basic load ratings				Allowable axial load		Allowable speed		Load center mm	Internal free space cm ³	Mass kg	Reference dimensions				Abutment and fillet dimensions					
	mm					dynamic kN	static kN	dynamic kgf	static kgf	(static) kN	kgf	grease lubrication min ⁻¹	oil lubrication min ⁻¹				mm				mm					
	d	D	B	$r_{s \min}^{1)}$	$r_{1s \min}^{1)}$	C_r	C_{Or}	C_r	C_{Or}								d_1	d_2	D_1	D_2	d_a min	d_b min	D_a max	D_b max	r_{as} max	r_{1as} max
2LA-HSE010AD	50	80	16	1	0.6	16.6	10.8	1 700	1 100	20.9	2 130	19 200	30 100	23.3	12	0.26	60.1	58.6	69.9	73.2	55.5	54.5	74.5	75.5	1	0.6
2LA-HSE011AD	55	90	18	1.1	0.6	18.1	12.9	1 840	1 310	24.8	2 530	17 200	27 000	26.1	16	0.40	67.6	66.2	77.4	80.8	62	59.5	83	85.5	1	0.6
2LA-HSE012AD	60	95	18	1.1	0.6	18.9	14.2	1 930	1 450	27.4	2 800	16 100	25 300	27.2	17	0.42	72.6	71.2	82.4	85.8	67	64.5	88	90.5	1	0.6
2LA-HSE013AD	65	100	18	1.1	0.6	19.2	14.9	1 960	1 520	28.9	2 940	15 100	23 700	28.4	18	0.45	77.6	76.2	87.4	90.8	72	69.5	93	95.5	1	0.6
2LA-HSE014AD	70	110	20	1.1	0.6	23.4	18.8	2 390	1 920	36.5	3 700	13 900	21 700	31.1	24	0.64	84.8	83.0	95.2	99.1	77	74.5	103	105.5	1	0.6
2LA-HSE015AD	75	115	20	1.1	0.6	25.0	21.2	2 550	2 160	41.0	4 200	13 200	20 600	32.3	25	0.68	89.8	88.0	100.2	104.1	82	79.5	108	110.5	1	0.6
2LA-HSE016AD	80	125	22	1.1	0.6	28.6	24.3	2 910	2 480	47.0	4 800	12 200	19 100	35.1	34	0.91	96.8	94.9	108.2	112.5	87	84.5	118	120.5	1	0.6
2LA-HSE017AD	85	130	22	1.1	0.6	28.9	25.4	2 950	2 590	49.0	5 000	11 600	18 200	36.2	35	0.96	101.8	99.9	113.2	117.4	92	89.5	123	125.5	1	0.6
2LA-HSE018AD	90	140	24	1.5	1	33.5	29.7	3 400	3 050	57.5	5 850	10 900	17 000	39.0	45	1.25	108.8	106.7	121.2	125.8	98.5	95.5	131.5	134.5	1.5	1
2LA-HSE019AD	95	145	24	1.5	1	34.0	31.0	3 450	3 150	60.0	6 100	10 400	16 300	40.2	47	1.30	113.8	111.7	126.2	130.8	103.5	100.5	136.5	139.5	1.5	1
2LA-HSE020AD	100	150	24	1.5	1	35.0	33.0	3 600	3 400	64.0	6 550	10 000	15 700	41.3	49	1.36	118.8	116.7	131.2	135.8	108.5	105.5	141.5	144.5	1.5	1
2LA-HSE021AD	105	160	26	2	1	40.5	38.5	4 100	3 900	74.5	7 600	9 400	14 800	44.1	61	1.73	125.8	123.6	139.2	144.1	115	110.5	150	154.5	2	1
2LA-HSE022AD	110	170	28	2	1	50.0	46.5	5 100	4 750	90.0	9 150	8 900	14 000	46.9	77	2.13	132.4	129.8	147.6	153.2	120	115.5	160	164.5	2	1
2LA-HSE024AD	120	180	28	2	1	50.5	48.5	5 150	4 950	94.0	9 550	8 300	13 000	49.2	82	2.28	142.4	139.8	157.6	163.2	130	125.5	170	174.5	2	1
2LA-HSE026AD	130	200	33	2	1	72.5	67.5	7 350	6 850	130	13 200	7 600	11 900	55.3	130	3.40	155.5	152.3	174.5	181.5	140	135.5	190	194.5	2	1
2LA-HSE028AD	140	210	33	2	1	74.5	73.0	7 600	7 400	141	14 300	7 100	11 200	57.6	129	3.68	165.5	162.4	184.5	191.5	150	145.5	200	204.5	2	1
2LA-HSE030AD	150	225	35	2.1	1.1	77.0	78.5	7 850	8 000	151	15 400	6 700	10 400	61.5	163	4.46	178.0	174.8	197.0	204.0	162	157	213	218	2	1
2LA-HSE032AD	160	240	38	2.1	1.1	90.0	91.5	9 150	9 350	177	18 000	6 200	9 800	66.0	206	5.46	189.5	186.0	210.5	218.2	172	167	228	233	2	1
2LA-HSE034AD	170	260	42	2.1	1.1	103	105	10 500	10 700	203	20 700	5 800	9 100	71.5	272	7.37	203.6	199.8	226.4	234.9	182	177	248	253	2	1

1) Minimum allowable value for corner radius dimension r or r_1 .

Angular Contact Ball Bearings for Radial Loads

Dynamic equivalent radial load
 $P_r = XF_r + YF_a$

e	Single row / Tandem				Back-to-back / Face-to-face			
	$F_a/F_r \leq e$	$F_a/F_r > e$	$F_a/F_r \leq e$	$F_a/F_r > e$	$F_a/F_r \leq e$	$F_a/F_r > e$	$F_a/F_r \leq e$	$F_a/F_r > e$
0.68	1	0	0.41	0.87	1	0.92	0.67	1.41

Static equivalent radial load
 $P_{0r} = X_0 F_r + Y_0 F_a$

Single row / Tandem		Back-to-back / Face-to-face	
X_0	Y_0	X_0	Y_0
0.5	0.38	1	0.76

When $P_{0r} < F_r$ with single-row or tandem arrangement, $P_{0r} = F_r$.

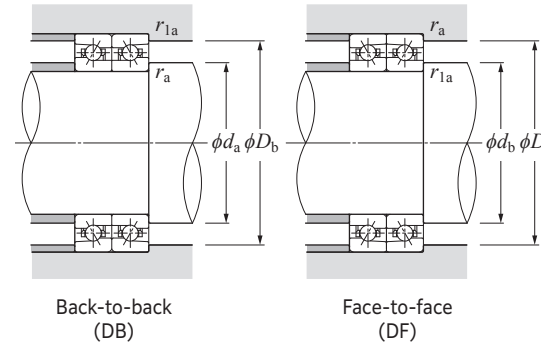

Angular Contact Ball Bearings for Radial Loads

ULTAGE High speed angular contact ball bearings (ceramic ball spec.)
5S-2LA-HSE9U type

Dimension Tables

NTN

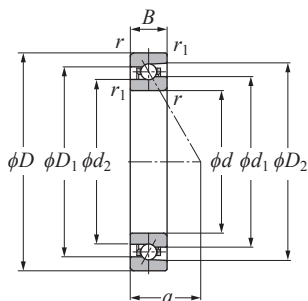

Contact angle 15° d 50–170 mm

Part number	Boundary dimensions						Basic load ratings				Allowable axial load		Factor f_0	Allowable speed		Load center a	Internal free space a	Mass	Reference dimensions				Abutment and fillet dimensions					
	mm						dynamic	static	dynamic	static	(static)	grease lubrication		oil lubrication	mm				mm									
	d	D	B	$r_{s \min}$	$r_{ls \min}$	C_r	C_{Or}	C_r	C_{Or}	(kN)					(kgf)				(kN)	(kgf)	d_1	d_2	D_1	D_2	d_a min	d_b min	D_a max	D_b max
5S-2LA-HSE910UC	50	72	12	0.6	0.3	12.1	5.65	1 240	575	7.45	760	7.6	25 600	42 400	14.2	6.0	0.12	57.6	56.6	64.4	66.8	54.5	52.5	67.5	69.5	0.6	0.3	
5S-2LA-HSE911UC	55	80	13	1	0.6	15.1	7.05	1 540	715	9.30	950	7.5	23 100	38 300	15.6	7.7	0.17	63.6	62.4	71.4	74.1	60.5	59.5	74.5	75.5	1	0.6	
5S-2LA-HSE912UC	60	85	13	1	0.6	15.7	7.70	1 600	785	10.1	1 040	7.6	21 500	35 700	16.3	8.3	0.18	68.6	67.4	76.4	79.1	65.5	64.5	79.5	80.5	1	0.6	
5S-2LA-HSE913UC	65	90	13	1	0.6	15.8	8.05	1 620	820	10.6	1 090	7.6	20 100	33 400	17.0	8.9	0.19	73.6	72.4	81.4	84.1	70.5	69.5	84.5	85.5	1	0.6	
5S-2LA-HSE914UC	70	100	16	1	0.6	23.2	11.5	2 370	1 170	15.2	1 560	7.5	18 400	30 400	19.5	14	0.31	80.1	78.6	89.8	93.2	75.5	74.5	94.5	95.5	1	0.6	
5S-2LA-HSE915UC	75	105	16	1	0.6	24.1	12.5	2 460	1 270	16.6	1 700	7.6	17 300	28 700	20.1	15	0.33	85.1	83.6	94.8	98.2	80.5	79.5	99.5	100.5	1	0.6	
5S-2LA-HSE916UC	80	110	16	1	0.6	24.4	13.0	2 490	1 330	17.3	1 770	7.6	16 400	27 200	20.8	16	0.34	90.1	88.6	99.8	103.2	85.5	84.5	104.5	105.5	1	0.6	
5S-2LA-HSE917UC	85	120	18	1.1	0.6	33.0	17.2	3 350	1 750	22.9	2 340	7.5	15 200	25 200	22.8	22	0.48	96.8	94.9	108.2	112.3	92	89.5	113	115.5	1	0.6	
5S-2LA-HSE918UC	90	125	18	1.1	0.6	34.5	18.6	3 500	1 900	24.8	2 530	7.6	14 500	24 100	23.5	23	0.51	101.8	99.9	113.2	117.3	97	94.5	118	120.5	1	0.6	
5S-2LA-HSE919UC	95	130	18	1.1	0.6	35.0	19.4	3 550	1 970	25.8	2 640	7.6	13 900	23 000	24.2	24	0.53	106.8	104.9	118.2	122.3	102	99.5	123	125.5	1	0.6	
5S-2LA-HSE920UC	100	140	20	1.1	0.6	40.5	22.7	4 100	2 310	29.9	3 050	7.6	13 000	21 600	26.2	32	0.74	113.8	111.7	126.2	130.7	107	104.5	133	135.5	1	0.6	
5S-2LA-HSE921UC	105	145	20	1.1	0.6	41.0	23.6	4 150	2 400	31.0	3 200	7.6	12 500	20 700	26.9	33	0.77	118.8	116.7	131.2	135.7	112	109.5	138	140.5	1	0.6	
5S-2LA-HSE922UC	110	150	20	1.1	0.6	41.5	24.5	4 200	2 500	32.0	3 300	7.7	12 000	19 900	27.5	35	0.80	123.8	121.7	136.2	140.7	117	114.5	143	145.5	1	0.6	
5S-2LA-HSE924UC	120	165	22	1.1	0.6	53.0	31.5	5 400	3 200	41.5	4 250	7.6	10 900	18 200	30.2	47	1.08	135.4	133.0	149.6	154.8	127	124.5	158	160.5	1	0.6	
5S-2LA-HSE926UC	130	180	24	1.5	1	65.5	38.5	6 700	3 950	51.0	5 250	7.6	10 100	16 700	32.9	62	1.40	146.9	144.2	163.1	168.9	138.5	135.5	171.5	174.5	1.5	1	
5S-2LA-HSE928UC	140	190	24	1.5	1	66.0	40.5	6 750	4 100	53.5	5 500	7.6	9 500	15 700	34.3	66	1.48	156.9	154.2	173.1	178.9	148.5	145.5	181.5	184.5	1.5	1	
5S-2LA-HSE930UC	150	210	28	2	1	88.0	53.5	8 950	5 450	71.5	7 300	7.6	8 700	14 400	38.3	99	2.30	170.5	167.3	189.5	196.4	160	155.5	200	204.5	2	1	
5S-2LA-HSE932UC	160	220	28	2	1	89.0	55.5	9 050	5 700	74.5	7 600	7.6	8 200	13 600	39.6	105	2.42	180.5	177.3	199.5	206.3	170	165.5	210	214.5	2	1	
5S-2LA-HSE934UC	170	230	28	2	1	89.5	58.0	9 150	5 900	77.0	7 900	7.7	7 800	12 900	41.0	111	2.55	190.5	187.3	209.5	216.3	180	175.5	220	224.5	2	1	

1) Minimum allowable value for corner radius dimension r or r_1 .

Angular Contact Ball Bearings for Radial Loads

Dimension Tables

NTN

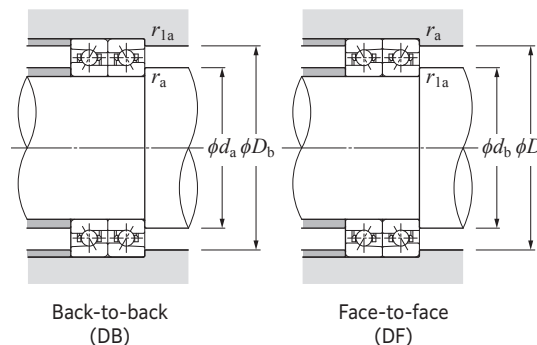

Dynamic equivalent radial load

$$P_r = X F_r + Y F_a$$

$i \cdot f_0 \cdot F_a$	e	Single row / Tandem				Back-to-back / Face-to-face			
		$F_a/F_r \leq e$		$F_a/F_r > e$		$F_a/F_r \leq e$		$F_a/F_r > e$	
		X	Y	X	Y	X	Y	X	Y
0.178	0.35			1.57		1.76		2.56	
0.357	0.36			1.53		1.71		2.48	
0.714	0.38			1.46		1.64		2.38	
1.07	0.4			1.42		1.59		2.31	
1.43	0.41	1	0	1.38	1	1.55	0.72	2.25	
2.14	0.43			1.33		1.49		2.16	
3.57	0.44			1.25		1.4		2.03	
5.35	0.47			1.18		1.32		1.92	
7.14	0.49			1.13		1.26		1.83	

Static equivalent radial load

$$P_{0r} = X_0 F_r + Y_0 F_a$$

Single row / Tandem		Back-to-back / Face-to-face	
X_0	Y_0	X_0	Y_0
0.52	0.54	1.04	1.08

When $P_{0r} < F_r$ with single-row or tandem arrangement, $P_{0r} = F_r$.

Main Spindle Bearings

Angular Contact Ball Bearings for Radial Loads

ULTAGE High speed angular contact ball bearings (ceramic ball spec.)
5S-2LA-HSE9U type

Dimension Tables

NTN

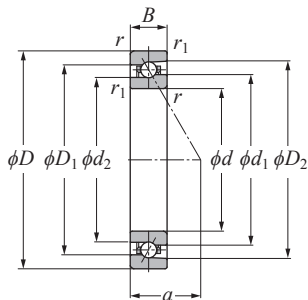

Contact angle 20° d 50–170 mm

Part number	Boundary dimensions						Basic load ratings				Allowable axial load		Allowable speed		Load center mm	Internal free space cm ³	Mass kg	Reference dimensions				Abutment and fillet dimensions					
	mm						dynamic kN	static kgf	dynamic kN	static kgf	(static)		grease lubrication	oil lubrication				mm				mm					
	d	D	B	r_s min ⁻¹	r_{1s} min ⁻¹	C_r	C_{Or}	C_r	C_{Or}	C_r	C_{Or}	(static)	(static)	min				max	d_a min	d_b min	D_a max	D_b max	r_{as} max	r_{1as} max			
5S-2LA-HSE910U	50	72	12	0.6	0.3	11.8	5.50	1 210	560	8.55	875	28 200	46 100	17.2	6.0	0.12	57.6	56.6	64.4	66.8	54.5	52.5	67.5	69.5	0.6	0.3	
5S-2LA-HSE911U	55	80	13	1	0.6	14.7	6.85	1 500	700	10.7	1 090	25 500	41 700	18.9	7.7	0.17	63.6	62.4	71.4	74.1	60.5	59.5	74.5	75.5	1	0.6	
5S-2LA-HSE912U	60	85	13	1	0.6	15.3	7.50	1 560	765	11.6	1 190	23 700	38 800	19.8	8.3	0.18	68.6	67.4	76.4	79.1	65.5	64.5	79.5	80.5	1	0.6	
5S-2LA-HSE913U	65	90	13	1	0.6	15.4	7.85	1 570	800	12.2	1 250	22 200	36 300	20.7	8.9	0.19	73.6	72.4	81.4	84.0	70.5	69.5	84.5	85.5	1	0.6	
5S-2LA-HSE914U	70	100	16	1	0.6	22.6	11.2	2 310	1 140	17.4	1 780	20 200	33 100	23.6	14	0.31	80.1	78.6	89.8	93.2	75.5	74.5	94.5	95.5	1	0.6	
5S-2LA-HSE915U	75	105	16	1	0.6	23.5	12.2	2 390	1 240	19.0	1 940	19 100	31 300	24.5	15	0.33	85.1	83.6	94.8	98.2	80.5	79.5	99.5	100.5	1	0.6	
5S-2LA-HSE916U	80	110	16	1	0.6	23.7	12.7	2 420	1 290	19.8	2 020	18 100	29 600	25.4	16	0.34	90.1	88.6	99.8	103.2	85.5	84.5	104.5	105.5	1	0.6	
5S-2LA-HSE917U	85	120	18	1.1	0.6	32.0	16.8	3 300	1 710	26.1	2 670	16 800	27 400	27.8	22	0.48	96.8	94.9	108.2	112.3	92	89.5	113	115.5	1	0.6	
5S-2LA-HSE918U	90	125	18	1.1	0.6	33.5	18.1	3 400	1 850	28.3	2 890	16 000	26 200	28.7	23	0.51	101.8	99.9	113.2	117.3	97	94.5	118	120.5	1	0.6	
5S-2LA-HSE919U	95	130	18	1.1	0.6	34.0	18.9	3 450	1 930	29.4	3 000	15 300	25 000	29.6	24	0.53	106.8	104.9	118.2	122.3	102	99.5	123	125.5	1	0.6	
5S-2LA-HSE920U	100	140	20	1.1	0.6	39.5	22.1	4 000	2 260	34.0	3 500	14 300	23 400	32.0	32	0.74	113.8	111.7	126.2	130.6	107	104.5	133	135.5	1	0.6	
5S-2LA-HSE921U	105	145	20	1.1	0.6	40.0	23.0	4 050	2 350	35.5	3 650	13 800	22 500	32.9	33	0.77	118.8	116.7	131.2	135.6	112	109.5	138	140.5	1	0.6	
5S-2LA-HSE922U	110	150	20	1.1	0.6	40.0	23.9	4 100	2 430	37.0	3 800	13 200	21 600	33.8	35	0.80	123.8	121.7	136.2	140.6	117	114.5	143	145.5	1	0.6	
5S-2LA-HSE924U	120	165	22	1.1	0.6	51.5	30.5	5 250	3 100	47.5	4 850	12 100	19 700	37.1	47	1.08	135.4	133.0	149.6	154.7	127	124.5	158	160.5	1	0.6	
5S-2LA-HSE926U	130	180	24	1.5	1	64.0	38.0	6 500	3 850	58.5	6 000	11 100	18 100	40.4	62	1.40	146.9	144.2	163.1	168.9	138.5	135.5	171.5	174.5	1.5	1	
5S-2LA-HSE928U	140	190	24	1.5	1	64.5	39.5	6 550	4 000	61.0	6 250	10 400	17 000	42.2	66	1.48	156.9	154.2	173.1	178.8	148.5	145.5	181.5	184.5	1.5	1	
5S-2LA-HSE930U	150	210	28	2	1	86.0	52.0	8 750	5 350	81.0	8 300	9 600	15 600	47.0	99	2.30	170.5	167.3	189.5	196.3	160	155.5	200	204.5	2	1	
5S-2LA-HSE932U	160	220	28	2	1	86.5	54.5	8 850	5 550	84.5	8 650	9 100	14 800	48.8	105	2.42	180.5	177.3	199.5	206.3	170	165.5	210	214.5	2	1	
5S-2LA-HSE934U	170	230	28	2	1	87.5	56.5	8 900	5 750	88.0	9 000	8 600	14 100	50.6	111	2.55	190.5	187.3	209.5	216.3	180	175.5	220	224.5	2	1	

1) Minimum allowable value for corner radius dimension r or r_1 .

Angular Contact Ball Bearings for Radial Loads

Dimension Tables

NTN

Dynamic equivalent radial load

$$P_r = X F_r + Y F_a$$

e	Single row / Tandem				Back-to-back / Face-to-face			
	$F_a/F_r \leq e$		$F_a/F_r > e$		$F_a/F_r \leq e$		$F_a/F_r > e$	
	X	Y	X	Y	X	Y	X	Y
0.57	1	0	0.43	1	1	1.09	0.7	1.63

Static equivalent radial load

$$P_{0r} = X_0 F_r + Y_0 F_a$$

e	Single row / Tandem		Back-to-back / Face-to-face	
	X_0	Y_0	X_0	Y_0
	0.5	0.5	0.42	1

When $P_{0r} < F_r$ with single-row or tandem arrangement, $P_{0r} = F_r$.

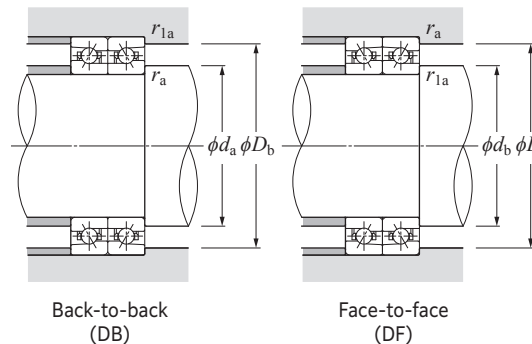

Main Spindle Bearings

Angular Contact Ball Bearings for Radial Loads

ULTAGE High speed angular contact ball bearings (ceramic ball spec.)
5S-2LA-HSE9U type

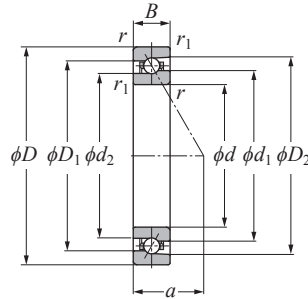

Contact angle 25° d 50–170 mm

Part number	Boundary dimensions					Basic load ratings				Allowable axial load		Allowable speed		Load center mm	Internal free space cm ³	Mass kg	Reference dimensions				Abutment and fillet dimensions					
	mm					dynamic kN	static kgf	dynamic kN	static kgf	(static) kN kgf		grease lubrication min ⁻¹	oil lubrication min ⁻¹				mm				mm					
	d	D	B	r_s min ¹⁾	r_{1s} min ¹⁾	C_r	C_{0r}	C_r	C_{0r}								d_1	d_2	D_1	D_2	d_a min	d_b min	D_a max	D_b max	r_{as} max	r_{1as} max
5S-2LA-HSE910UAD	50	72	12	0.6	0.3	11.4	5.30	1 170	545	9.75	995	24 300	41 000	20.3	6.0	0.12	57.6	56.6	64.4	66.7	54.5	52.5	67.5	69.5	0.6	0.3
5S-2LA-HSE911UAD	55	80	13	1	0.6	14.3	6.65	1 450	680	12.1	1 240	22 000	37 000	22.4	7.7	0.17	63.6	62.4	71.4	74.1	60.5	59.5	74.5	75.5	1	0.6
5S-2LA-HSE912UAD	60	85	13	1	0.6	14.8	7.25	1 510	740	13.3	1 360	20 500	34 500	23.5	8.3	0.18	68.6	67.4	76.4	79.0	65.5	64.5	79.5	80.5	1	0.6
5S-2LA-HSE913UAD	65	90	13	1	0.6	14.9	7.60	1 520	775	13.9	1 420	19 200	32 300	24.7	8.9	0.19	73.6	72.4	81.4	84.0	70.5	69.5	84.5	85.5	1	0.6
5S-2LA-HSE914UAD	70	100	16	1	0.6	21.9	10.8	2 230	1 100	19.9	2 030	17 500	29 400	28.0	14	0.31	80.1	78.6	89.8	93.2	75.5	74.5	94.5	95.5	1	0.6
5S-2LA-HSE915UAD	75	105	16	1	0.6	22.7	11.8	2 310	1 200	21.5	2 200	16 500	27 800	29.1	15	0.33	85.1	83.6	94.8	98.2	80.5	79.5	99.5	100.5	1	0.6
5S-2LA-HSE916UAD	80	110	16	1	0.6	23.0	12.3	2 340	1 250	22.5	2 300	15 600	26 300	30.3	16	0.34	90.1	88.6	99.8	103.2	85.5	84.5	104.5	105.5	1	0.6
5S-2LA-HSE917UAD	85	120	18	1.1	0.6	31.0	16.2	3 150	1 660	29.4	3 000	14 500	24 400	33.1	22	0.48	96.8	94.9	108.2	112.3	92	89.5	113	115.5	1	0.6
5S-2LA-HSE918UAD	90	125	18	1.1	0.6	32.5	17.6	3 300	1 790	31.5	3 250	13 800	23 300	34.2	23	0.51	101.8	99.9	113.2	117.3	97	94.5	118	120.5	1	0.6
5S-2LA-HSE919UAD	95	130	18	1.1	0.6	32.5	18.3	3 350	1 870	33.0	3 400	13 200	22 200	35.4	24	0.53	106.8	104.9	118.2	122.3	102	99.5	123	125.5	1	0.6
5S-2LA-HSE920UAD	100	140	20	1.1	0.6	38.0	21.4	3 850	2 190	39.0	4 000	12 400	20 800	38.2	32	0.74	113.8	111.7	126.2	130.6	107	104.5	133	135.5	1	0.6
5S-2LA-HSE921UAD	105	145	20	1.1	0.6	38.5	22.3	3 900	2 270	40.5	4 150	11 900	20 000	39.3	33	0.77	118.8	116.7	131.2	135.6	112	109.5	138	140.5	1	0.6
5S-2LA-HSE922UAD	110	150	20	1.1	0.6	39.0	23.1	3 950	2 360	42.0	4 300	11 400	19 200	40.5	35	0.80	123.8	121.7	136.2	140.6	117	114.5	143	145.5	1	0.6
5S-2LA-HSE924UAD	120	165	22	1.1	0.6	50.0	29.6	5 100	3 000	54.0	5 550	10 400	17 500	44.4	47	1.08	135.4	133.0	149.6	154.7	127	124.5	158	160.5	1	0.6
5S-2LA-HSE926UAD	130	180	24	1.5	1	61.5	36.5	6 300	3 750	67.0	6 850	9 600	16 100	48.4	62	1.40	146.9	144.2	163.1	168.8	138.5	135.5	171.5	174.5	1.5	1
5S-2LA-HSE928UAD	140	190	24	1.5	1	62.0	38.0	6 350	3 900	70.0	7 150	9 000	15 200	50.7	66	1.48	156.9	154.2	173.1	178.8	148.5	145.5	181.5	184.5	1.5	1
5S-2LA-HSE930UAD	150	210	28	2	1	83.0	50.5	8 450	5 150	92.5	9 450	8 200	13 900	56.3	99	2.30	170.5	167.3	189.5	196.3	160	155.5	200	204.5	2	1
5S-2LA-HSE932UAD	160	220	28	2	1	83.5	52.5	8 550	5 350	96.5	9 850	7 800	13 200	58.6	105	2.42	180.5	177.3	199.5	206.3	170	165.5	210	214.5	2	1
5S-2LA-HSE934UAD	170	230	28	2	1	84.5	54.5	8 600	5 600	100	10 200	7 400	12 500	60.9	111	2.55	190.5	187.3	209.5	216.3	180	175.5	220	224.5	2	1

1) Minimum allowable value for corner radius dimension r or r_1 .

Angular Contact Ball Bearings for Radial Loads

Dynamic equivalent radial load
 $P_r = XF_r + YF_a$

e	Single row / Tandem				Back-to-back / Face-to-face			
	$F_a/F_r \leq e$		$F_a/F_r > e$		$F_a/F_r \leq e$		$F_a/F_r > e$	
	X	Y	X	Y	X	Y	X	Y
0.68	1	0	0.41	0.87	1	0.92	0.67	1.41

Static equivalent radial load
 $P_{0r} = X_0 F_r + Y_0 F_a$

e	Single row / Tandem		Back-to-back / Face-to-face	
	X_0	Y_0	X_0	Y_0
	0.5	0.38	1	0.76

When $P_{0r} < F_r$ with single-row or tandem arrangement, $P_{0r} = F_r$.

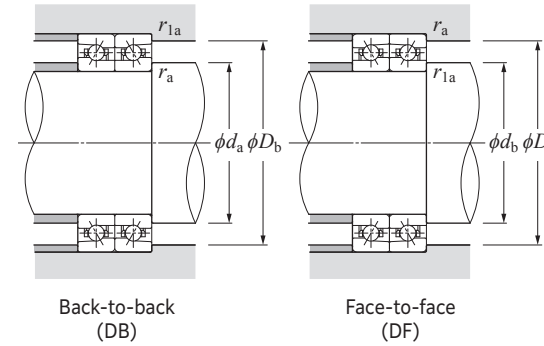

Angular Contact Ball Bearings for Radial Loads

ULTAGE High speed angular contact ball bearings (ceramic ball spec.)
5S-2LA-HSE0 type

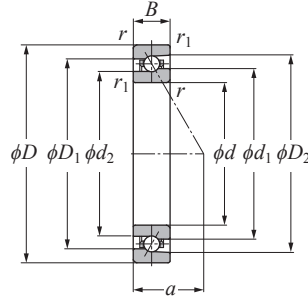

Contact angle 15° d 50–170 mm

Part number	Boundary dimensions						Basic load ratings				Allowable axial load		Factor f_0	Allowable speed		Load center mm a	Internal free space cm^3	Mass kg	Reference dimensions				Abutment and fillet dimensions					
	mm						dynamic kN		static kgf		(static) kN	kgf		grease lubrication min^{-1}	oil lubrication min^{-1}				mm				mm					
	d	D	B	$r_{s min}^{(1)}$	$r_{is min}^{(1)}$	C_r	C_{0r}	C_r	C_{0r}	d_1									d_2	D_1	D_2	d_a min	d_b min	D_a max	D_b max	r_{as} max	r_{las} max	
5S-2LA-HSE010C	50	80	16	1	0.6	17.6	7.90	1 800	805	10.5	1 070	7.2	24 000	39 800	16.8	12	0.23	60.1	58.6	69.9	73.3	55.5	54.5	74.5	75.5	1	0.6	
5S-2LA-HSE011C	55	90	18	1.1	0.6	19.1	9.40	1 950	960	12.5	1 280	7.4	21 500	35 700	18.8	16	0.37	67.6	66.2	77.4	80.8	62	59.5	83	85.5	1	0.6	
5S-2LA-HSE012C	60	95	18	1.1	0.6	20.0	10.4	2 040	1 060	13.9	1 420	7.4	20 100	33 400	19.5	17	0.40	72.6	71.2	82.4	85.8	67	64.5	88	90.5	1	0.6	
5S-2LA-HSE013C	65	100	18	1.1	0.6	20.3	10.9	2 070	1 120	14.6	1 490	7.5	18 900	31 400	20.1	18	0.42	77.6	76.2	87.4	90.8	72	69.5	93	95.5	1	0.6	
5S-2LA-HSE014C	70	110	20	1.1	0.6	24.9	13.8	2 540	1 410	18.4	1 880	7.5	17 300	28 700	22.2	24	0.60	84.8	83.0	95.2	99.1	77	74.5	103	105.5	1	0.6	
5S-2LA-HSE015C	75	115	20	1.1	0.6	26.5	15.5	2 700	1 590	20.8	2 120	7.5	16 400	27 200	22.8	25	0.64	89.8	88.0	100.2	104.1	82	79.5	108	110.5	1	0.6	
5S-2LA-HSE016C	80	125	22	1.1	0.6	30.5	17.8	3 100	1 820	23.8	2 430	7.5	15 200	25 200	24.8	34	0.86	96.8	94.9	108.2	112.5	87	84.5	118	120.5	1	0.6	
5S-2LA-HSE017C	85	130	22	1.1	0.6	30.5	18.6	3 150	1 900	24.9	2 540	7.6	14 500	24 100	25.5	35	0.90	101.8	99.9	113.2	117.5	92	89.5	123	125.5	1	0.6	
5S-2LA-HSE018C	90	140	24	1.5	1	35.5	21.8	3 650	2 220	29.2	2 970	7.6	13 600	22 500	27.5	45	1.18	108.8	106.7	121.2	125.8	98.5	95.5	131.5	134.5	1.5	1	
5S-2LA-HSE019C	95	145	24	1.5	1	36.0	22.7	3 700	2 310	30.5	3 100	7.6	13 000	21 600	28.2	47	1.23	113.8	111.7	126.2	130.8	103.5	100.5	136.5	139.5	1.5	1	
5S-2LA-HSE020C	100	150	24	1.5	1	37.5	24.4	3 800	2 480	32.5	3 350	7.6	12 500	20 700	28.9	49	1.28	118.8	116.7	131.2	135.8	108.5	105.5	141.5	144.5	1.5	1	
5S-2LA-HSE021C	105	160	26	2	1	43.0	28.2	4 350	2 880	38.0	3 850	7.6	11 800	19 500	30.9	61	1.63	125.8	123.6	139.2	144.1	115	110.5	150	154.5	2	1	
5S-2LA-HSE022C	110	170	28	2	1	53.0	34.0	5 400	3 500	45.5	4 650	7.6	11 100	18 500	32.9	77	1.99	132.4	129.8	147.6	153.3	120	115.5	160	164.5	2	1	
5S-2LA-HSE024C	120	180	28	2	1	53.5	35.5	5 450	3 650	47.5	4 850	7.6	10 400	17 200	34.2	82	2.14	142.4	139.8	157.6	163.3	130	125.5	170	174.5	2	1	
5S-2LA-HSE026C	130	200	33	2	1	76.5	49.5	7 800	5 000	66.0	6 700	7.5	9 500	15 700	38.8	130	3.18	155.5	152.3	174.5	181.6	140	135.5	190	194.5	2	1	
5S-2LA-HSE028C	140	210	33	2	1	79.5	53.5	8 100	5 450	71.5	7 300	7.6	8 900	14 800	40.1	129	3.41	165.5	162.4	184.5	191.5	150	145.5	200	204.5	2	1	
5S-2LA-HSE030C	150	225	35	2.1	1.1	81.5	57.5	8 300	5 850	77.0	7 850	7.6	8 300	13 800	42.8	163	4.17	178.0	174.8	197.0	204.1	162	157	213	218	2	1	
5S-2LA-HSE032C	160	240	38	2.1	1.1	95.5	67.0	9 750	6 850	90.0	9 150	7.6	7 800	12 900	46.0	206	5.09	189.5	186.0	210.5	218.2	172	167	228	233	2	1	
5S-2LA-HSE034C	170	260	42	2.1	1.1	110	77.0	11 200	7 850	103	10 500	7.6	7 300	12 000	50.0	272	6.90	203.6	199.8	226.4	234.9	182	177	248	253	2	1	

1) Minimum allowable value for corner radius dimension r or r_1 .

Angular Contact Ball Bearings for Radial Loads

Dynamic equivalent radial load
 $P_r = X F_r + Y F_a$

$i f_0 F_a$	C_{0r}	e	Single row / Tandem				Back-to-back / Face-to-face			
			$F_a/F_r \leq e$		$F_a/F_r > e$		$F_a/F_r \leq e$		$F_a/F_r > e$	
			X	Y	X	Y	X	Y	X	Y
0.178	0.35				1.57		1.76		2.56	
0.357	0.36				1.53		1.71		2.48	
0.714	0.38				1.46		1.64		2.38	
1.07	0.4				1.42		1.59		2.31	
1.43	0.41	1	0	0.44	1.38	1	1.55	0.72	2.25	
2.14	0.43				1.33		1.49		2.16	
3.57	0.44				1.25		1.4		2.03	
5.35	0.47				1.18		1.32		1.92	
7.14	0.49				1.13		1.26		1.83	

Static equivalent radial load

$P_{0r} = X_0 F_r + Y_0 F_a$

Single row / Tandem		Back-to-back / Face-to-face	
X_0	Y_0	X_0	Y_0
0.52	0.54	1.04	1.08

When $P_{0r} < F_r$ with single-row or tandem arrangement, $P_{0r} = F_r$.

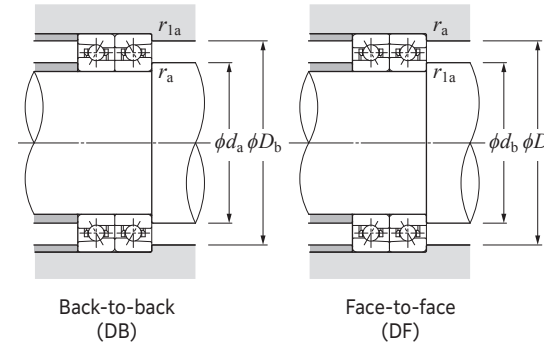

Angular Contact Ball Bearings for Radial Loads

ULTAGE High speed angular contact ball bearings (ceramic ball spec.)
5S-2LA-HSE0 type

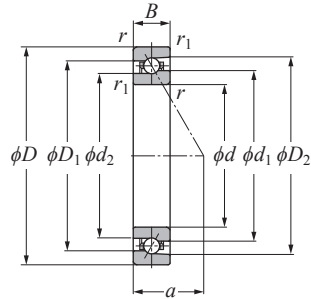

Contact angle 20° d 50–170 mm

Part number	Boundary dimensions					Basic load ratings				Allowable axial load		Allowable speed		Load center mm	Internal free space cm ³	Mass kg	Reference dimensions				Abutment and fillet dimensions					
	mm					dynamic kN		static kgf		(static)		min ⁻¹					mm				mm					
	d	D	B	$r_{s \min}^{1)}$	$r_{ls \min}^{1)}$	C_r	C_{0r}	C_r	C_{0r}	(static)	(static)	grease lubrication	oil lubrication				a	Single-row (approx.)	Single-row (approx.)	d_1	d_2	D_1	D_2	d_a min	d_b min	D_a max
5S-2LA-HSE010	50	80	16	1	0.6	17.2	7.75	1 750	790	12.1	1 230	26 500	43 300	19.9	12	0.23	60.1	58.6	69.9	73.2	55.5	54.5	74.5	75.5	1	0.6
5S-2LA-HSE011	55	90	18	1.1	0.6	18.7	9.20	1 900	935	14.4	1 460	23 700	38 800	22.3	16	0.37	67.6	66.2	77.4	80.8	62	59.5	83	85.5	1	0.6
5S-2LA-HSE012	60	95	18	1.1	0.6	19.5	10.2	1 990	1 040	15.9	1 620	22 200	36 300	23.2	17	0.40	72.6	71.2	82.4	85.8	67	64.5	88	90.5	1	0.6
5S-2LA-HSE013	65	100	18	1.1	0.6	19.8	10.7	2 020	1 090	16.7	1 710	20 800	34 100	24.1	18	0.42	77.6	76.2	87.4	90.8	72	69.5	93	95.5	1	0.6
5S-2LA-HSE014	70	110	20	1.1	0.6	24.2	13.5	2 470	1 370	21.1	2 150	19 100	31 200	26.5	24	0.60	84.8	83.0	95.2	99.1	77	74.5	103	105.5	1	0.6
5S-2LA-HSE015	75	115	20	1.1	0.6	25.8	15.2	2 630	1 550	23.8	2 420	18 100	29 600	27.4	25	0.64	89.8	88.0	100.2	104.1	82	79.5	108	110.5	1	0.6
5S-2LA-HSE016	80	125	22	1.1	0.6	29.6	17.4	3 000	1 770	27.2	2 780	16 800	27 400	29.8	34	0.86	96.8	94.9	108.2	112.5	87	84.5	118	120.5	1	0.6
5S-2LA-HSE017	85	130	22	1.1	0.6	30.0	18.1	3 050	1 850	28.4	2 900	16 000	26 200	30.7	35	0.90	101.8	99.9	113.2	117.4	92	89.5	123	125.5	1	0.6
5S-2LA-HSE018	90	140	24	1.5	1	34.5	21.3	3 550	2 170	33.5	3 400	15 000	24 500	33.1	45	1.18	108.8	106.7	121.2	125.8	98.5	95.5	131.5	134.5	1.5	1
5S-2LA-HSE019	95	145	24	1.5	1	35.0	22.1	3 600	2 260	34.5	3 550	14 300	23 400	34.0	47	1.23	113.8	111.7	126.2	130.8	103.5	100.5	136.5	139.5	1.5	1
5S-2LA-HSE020	100	150	24	1.5	1	36.5	23.8	3 700	2 420	37.5	3 800	13 800	22 500	34.9	49	1.28	118.8	116.7	131.2	135.8	108.5	105.5	141.5	144.5	1.5	1
5S-2LA-HSE021	105	160	26	2	1	42.0	27.5	4 250	2 810	43.0	4 400	13 000	21 200	37.3	61	1.63	125.8	123.6	139.2	144.1	115	110.5	150	154.5	2	1
5S-2LA-HSE022	110	170	28	2	1	51.5	33.5	5 300	3 400	52.0	5 300	12 300	20 100	39.7	77	1.99	132.4	129.8	147.6	153.2	120	115.5	160	164.5	2	1
5S-2LA-HSE024	120	180	28	2	1	52.0	35.0	5 300	3 550	54.5	5 550	11 500	18 700	41.5	82	2.14	142.4	139.8	157.6	163.2	130	125.5	170	174.5	2	1
5S-2LA-HSE026	130	200	33	2	1	74.5	48.0	7 600	4 900	75.5	7 700	10 400	17 000	46.8	130	3.18	155.5	152.3	174.5	181.5	140	135.5	190	194.5	2	1
5S-2LA-HSE028	140	210	33	2	1	77.5	52.0	7 900	5 300	81.5	8 300	9 800	16 100	48.6	129	3.41	165.5	162.4	184.5	191.5	150	145.5	200	204.5	2	1
5S-2LA-HSE030	150	225	35	2.1	1.1	79.5	56.0	8 100	5 700	88.0	8 950	9 200	15 000	51.9	163	4.17	178.0	174.8	197.0	204.0	162	157	213	218	2	1
5S-2LA-HSE032	160	240	38	2.1	1.1	93.0	65.5	9 500	6 700	103	10 500	8 600	14 100	55.7	206	5.09	189.5	186.0	210.5	218.2	172	167	228	233	2	1
5S-2LA-HSE034	170	260	42	2.1	1.1	107	75.0	10 900	7 650	118	12 000	8 000	13 100	60.4	272	6.90	203.6	199.8	226.4	234.9	182	177	248	253	2	1

1) Minimum allowable value for corner radius dimension r or r_1 .

Angular Contact Ball Bearings for Radial Loads

Dynamic equivalent radial load
 $P_r = X F_r + Y F_a$

e	Single row / Tandem				Back-to-back / Face-to-face			
	$F_a/F_r \leq e$		$F_a/F_r > e$		$F_a/F_r \leq e$		$F_a/F_r > e$	
	X	Y	X	Y	X	Y	X	Y
0.57	1	0	0.43	1	1	1.09	0.7	1.63

Static equivalent radial load
 $P_{0r} = X_0 F_r + Y_0 F_a$

e	Single row / Tandem		Back-to-back / Face-to-face	
	X_0	Y_0	X_0	Y_0
	0.5	0.42	1	0.84

When $P_{0r} < F_r$ with single-row or tandem arrangement, $P_{0r} = F_r$.

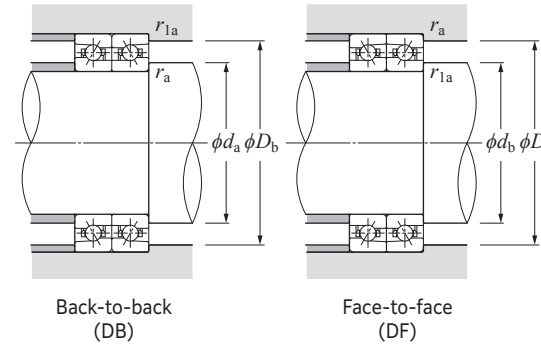

Angular Contact Ball Bearings for Radial Loads

ULTAGE High speed angular contact ball bearings (ceramic ball spec.)
5S-2LA-HSE0 type

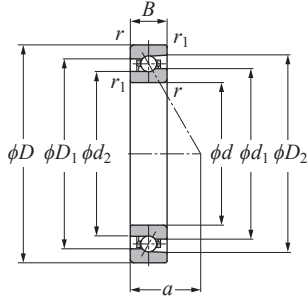

Contact angle 25° d 50–170 mm

Part number	Boundary dimensions						Basic load ratings				Allowable axial load		Allowable speed		Load center mm	Internal free space cm ³	Mass kg	Reference dimensions				Abutment and fillet dimensions					
	mm						dynamic kN	static kN	dynamic kgf	static kgf	(static)		grease lubrication	oil lubrication				mm				mm					
	d	D	B	r_s min ¹⁾	r_{1s} min ¹⁾	C_r	C_{Or}	C_r	C_{Or}	C_r	C_{Or}	(static)	(static)	d_1				d_2	D_1	D_2	d_a min	d_b min	D_a max	D_b max	r_{as} max	r_{1as} max	
5S-2LA-HSE010AD	50	80	16	1	0.6	16.6	7.50	1 700	765	13.8	1 400	22 800	38 500	23.3	12	0.23	60.1	58.6	69.9	73.2	55.5	54.5	74.5	75.5	1	0.6	
5S-2LA-HSE011AD	55	90	18	1.1	0.6	18.1	8.90	1 840	910	16.4	1 670	20 500	34 500	26.1	16	0.37	67.6	66.2	77.4	80.8	62	59.5	83	85.5	1	0.6	
5S-2LA-HSE012AD	60	95	18	1.1	0.6	18.9	9.85	1 930	1 000	18.1	1 850	19 200	32 300	27.2	17	0.40	72.6	71.2	82.4	85.8	67	64.5	88	90.5	1	0.6	
5S-2LA-HSE013AD	65	100	18	1.1	0.6	19.2	10.4	1 960	1 060	19.0	1 940	18 000	30 300	28.4	18	0.40	77.6	76.2	87.4	90.8	72	69.5	93	95.5	1	0.6	
5S-2LA-HSE014AD	70	110	20	1.1	0.6	23.4	13.0	2 390	1 330	24.0	2 440	16 500	27 800	31.1	24	0.60	84.8	83.0	95.2	99.1	77	74.5	103	105.5	1	0.6	
5S-2LA-HSE015AD	75	115	20	1.1	0.6	25.0	14.7	2 550	1 500	27.0	2 760	15 600	26 300	32.3	25	0.64	89.8	88.0	100.2	104.1	82	79.5	108	110.5	1	0.6	
5S-2LA-HSE016AD	80	125	22	1.1	0.6	28.6	16.9	2 910	1 720	31.0	3 150	14 500	24 400	35.1	34	0.86	96.8	94.9	108.2	112.5	87	84.5	118	120.5	1	0.6	
5S-2LA-HSE017AD	85	130	22	1.1	0.6	28.9	17.6	2 950	1 790	32.5	3 300	13 800	23 300	36.2	35	0.90	101.8	99.9	113.2	117.4	92	89.5	123	125.5	1	0.6	
5S-2LA-HSE018AD	90	140	24	1.5	1	33.5	20.6	3 400	2 100	38.0	3 850	12 900	21 700	39.0	45	1.18	108.8	106.7	121.2	125.8	98.5	95.5	131.5	134.5	1.5	1	
5S-2LA-HSE019AD	95	145	24	1.5	1	34.0	21.4	3 450	2 190	39.5	4 000	12 400	20 800	40.2	47	1.23	113.8	111.7	126.2	130.8	103.5	100.5	136.5	139.5	1.5	1	
5S-2LA-HSE020AD	100	150	24	1.5	1	35.0	23.0	3 600	2 350	42.5	4 300	11 900	20 000	41.3	49	1.28	118.8	116.7	131.2	135.8	108.5	105.5	141.5	144.5	1.5	1	
5S-2LA-HSE021AD	105	160	26	2	1	40.5	26.7	4 100	2 720	49.0	5 000	11 200	18 900	44.1	61	1.63	125.8	123.6	139.2	144.1	115	110.5	150	154.5	2	1	
5S-2LA-HSE022AD	110	170	28	2	1	50.0	32.5	5 100	3 300	59.5	6 050	10 600	17 900	46.9	77	1.99	132.4	129.8	147.6	153.2	120	115.5	160	164.5	2	1	
5S-2LA-HSE024AD	120	180	28	2	1	50.5	33.5	5 150	3 450	62.0	6 300	9 900	16 700	49.2	82	2.14	142.4	139.8	157.6	163.2	130	125.5	170	174.5	2	1	
5S-2LA-HSE026AD	130	200	33	2	1	72.5	46.5	7 350	4 750	85.5	8 750	9 000	15 200	55.3	130	3.18	155.5	152.3	174.5	181.5	140	135.5	190	194.5	2	1	
5S-2LA-HSE028AD	140	210	33	2	1	74.5	50.5	7 600	5 150	92.5	9 450	8 500	14 300	57.6	129	3.41	165.5	162.4	184.5	191.5	150	145.5	200	204.5	2	1	
5S-2LA-HSE030AD	150	225	35	2.1	1.1	77.0	54.5	7 850	5 550	100	10 200	7 900	13 300	61.5	163	4.17	178.0	174.8	197.0	204.0	162	157	213	218	2	1	
5S-2LA-HSE032AD	160	240	38	2.1	1.1	90.0	63.5	9 150	6 450	117	11 900	7 400	12 500	66.0	206	5.09	189.5	186.0	210.5	218.2	172	167	228	233	2	1	
5S-2LA-HSE034AD	170	260	42	2.1	1.1	103	73.0	10 500	7 450	134	13 700	6 900	11 600	71.5	272	6.90	203.6	199.8	226.4	234.9	182	177	248	253	2	1	

1) Minimum allowable value for corner radius dimension r or r_1 .

Angular Contact Ball Bearings for Radial Loads

Dynamic equivalent radial load
 $P_r = X F_r + Y F_a$

e	Single row / Tandem				Back-to-back / Face-to-face			
	$F_a/F_r \leq e$		$F_a/F_r > e$		$F_a/F_r \leq e$		$F_a/F_r > e$	
	X	Y	X	Y	X	Y	X	Y
0.68	1	0	0.41	0.87	1	0.92	0.67	1.41

Static equivalent radial load
 $P_{0r} = X_0 F_r + Y_0 F_a$

e	Single row / Tandem		Back-to-back / Face-to-face	
	X_0	Y_0	X_0	Y_0
	0.5	0.5	0.38	1

When $P_{0r} < F_r$ with single-row or tandem arrangement, $P_{0r} = F_r$.

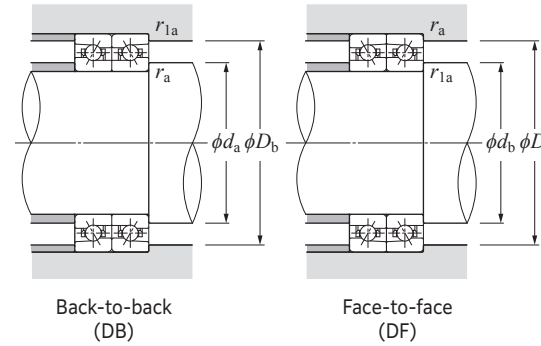

Main Spindle Bearings

Main Spindle Bearings

Angular Contact Ball Bearings for Radial Loads

ULTAGE Ultra high speed angular contact ball bearings (ceramic ball spec.)
5S-2LA-HSF0 type

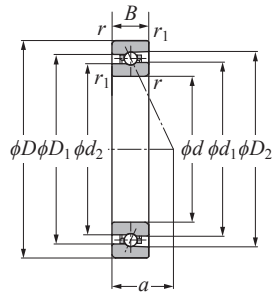

Contact angle 25° d 50–100 mm

Part number	Boundary dimensions					Basic load ratings				Allowable axial load		Allowable speed min ⁻¹ oil lubrication	Load center mm a	Internal free space cm ³ Single-row (approx.)	Mass kg Single-row (approx.)	Reference dimensions				Abutment and fillet dimensions					
	mm					dynamic kN	static kN	dynamic kgf	static kgf	kN	kgf					mm				mm					
	d	D	B	$r_s \min^1$	$r_{1s} \min^1$	C_r	C_{0r}	C_r	C_{0r}	(static)						d_1	d_2	D_1	D_2	d_a min	d_b min	D_a max	D_b max	r_{as} max	r_{1as} max
5S-2LA-HSF010AD	50	80	16	1	0.6	11.1	6.20	1 140	635	11.4	1 170	50 000	23.3	10	0.29	61.6	60.6	68.4	70.9	55.5	54.5	74.5	75.5	1	0.6
5S-2LA-HSF011AD	55	90	18	1.1	0.6	13.9	7.80	1 420	800	14.4	1 470	44 800	26.0	14	0.42	68.6	67.4	76.4	79.2	62	59.5	83	85.5	1	0.6
5S-2LA-HSF012AD	60	95	18	1.1	0.6	14.3	8.45	1 460	860	15.5	1 580	41 900	27.2	15	0.45	73.6	72.4	81.4	84.2	67	64.5	88	90.5	1	0.6
5S-2LA-HSF013AD	65	100	18	1.1	0.6	14.7	9.05	1 500	925	16.7	1 700	39 400	28.3	16	0.48	78.6	77.4	86.4	89.2	72	69.5	93	95.5	1	0.6
5S-2LA-HSF014AD	70	110	20	1.1	0.6	18.0	11.1	1 830	1 130	20.4	2 080	36 100	31.1	22	0.67	85.6	84.3	94.4	97.5	77	74.5	103	105.5	1	0.6
5S-2LA-HSF015AD	75	115	20	1.1	0.6	18.5	11.9	1 880	1 210	21.8	2 220	34 200	32.3	24	0.71	90.6	89.3	99.4	102.5	82	79.5	108	110.5	1	0.6
5S-2LA-HSF016AD	80	125	22	1.1	0.6	22.0	14.2	2 250	1 440	26.0	2 660	31 700	35.0	31	0.95	97.6	96.2	107.4	110.8	87	84.5	118	120.5	1	0.6
5S-2LA-HSF017AD	85	130	22	1.1	0.6	22.2	14.7	2 270	1 500	27.0	2 750	30 200	36.2	33	1.00	102.6	101.2	112.4	115.8	92	89.5	123	125.5	1	0.6
5S-2LA-HSF018AD	90	140	24	1.5	1	27.1	18.2	2 760	1 860	33.5	3 400	28 300	39.0	41	1.31	109.8	108.0	120.2	124.2	98.5	95.5	131.5	134.5	1.5	1
5S-2LA-HSF019AD	95	145	24	1.5	1	27.3	18.8	2 790	1 920	34.5	3 550	27 100	40.1	43	1.36	114.8	113.0	125.2	129.2	103.5	100.5	136.5	139.5	1.5	1
5S-2LA-HSF020AD	100	150	24	1.5	1	28.1	20.0	2 860	2 040	37.0	3 750	26 000	41.3	45	1.42	119.8	118.0	130.2	134.2	108.5	105.5	141.5	144.5	1.5	1

1) Minimum allowable value for corner radius dimension r or r_1 .

Angular Contact Ball Bearings for Radial Loads

Dynamic equivalent radial load
 $P_r = X F_r + Y F_a$

e	Single row / Tandem				Back-to-back / Face-to-face			
	$F_a/F_r \leq e$		$F_a/F_r > e$		$F_a/F_r \leq e$		$F_a/F_r > e$	
	X	Y	X	Y	X	Y	X	Y
0.68	1	0	0.41	0.87	1	0.92	0.67	1.41

Static equivalent radial load
 $P_{0r} = X_0 F_r + Y_0 F_a$

Single row / Tandem		Back-to-back / Face-to-face	
X_0	Y_0	X_0	Y_0
0.5	0.38	1	0.76

When $P_{0r} < F_r$ with single-row or tandem arrangement, $P_{0r} = F_r$.

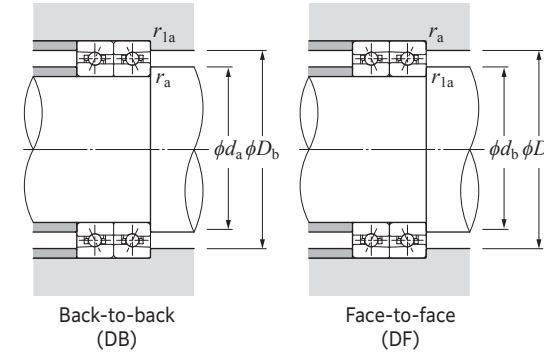

Angular Contact Ball Bearings for Radial Loads Dimension Tables



ULTAGE Eco-friendly high speed angular contact ball bearings
(ceramic ball spec.)
5S-2LA-HSL9U type

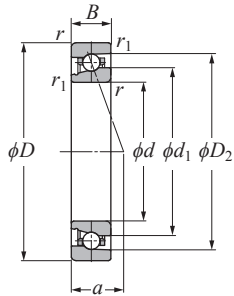

Contact angle 20° d 50–130 mm

Part number	Boundary dimensions					Basic load ratings				Allowable axial load		Allowable speed min ⁻¹ oil lubrication	Load center mm <i>a</i>	Mass kg Single-row (approx.)	Reference dimensions		Abutment and fillet dimensions					Part number
	mm					dynamic kN	static kgf	dynamic kgf	static kN	(static)	mm				<i>d</i> ₁	<i>D</i> ₂	mm					
	<i>d</i>	<i>D</i>	<i>B</i>	<i>r</i> _{s min} ¹⁾	<i>r</i> _{1s min} ¹⁾	<i>C</i> _r	<i>C</i> _{0r}	<i>C</i> _r	<i>C</i> _{0r}								<i>d</i> _a min	<i>D</i> _b max	<i>r</i> _{as} max	<i>r</i> _{1as} max	<i>l</i> ²⁾ min	
5S-2LA-HSL910U	50	72	12	0.6	0.3	11.8	5.50	1 210	560	8.55	875	46 100	17.2	0.11	57.6	66.8	54.5	69.5	0.6	0.3	8.5	5S-2LA-HSL910U
5S-2LA-HSL911U	55	80	13	1	0.6	14.7	6.85	1 500	700	10.6	1 090	41 700	18.9	0.16	63.6	74.1	60.5	75.5	1	0.6	8.5	5S-2LA-HSL911U
5S-2LA-HSL912U	60	85	13	1	0.6	15.3	7.50	1 560	765	11.6	1 190	38 800	19.8	0.17	68.6	79.1	65.5	80.5	1	0.6	8.5	5S-2LA-HSL912U
5S-2LA-HSL913U	65	90	13	1	0.6	15.4	7.85	1 570	800	12.2	1 250	36 300	20.7	0.17	73.6	84.0	70.5	85.5	1	0.6	8.5	5S-2LA-HSL913U
5S-2LA-HSL914U	70	100	16	1	0.6	22.6	11.2	2 310	1 140	17.4	1 780	33 100	23.6	0.29	80.1	93.2	75.5	95.5	1	0.6	8.5	5S-2LA-HSL914U
5S-2LA-HSL915U	75	105	16	1	0.6	23.5	12.2	2 390	1 240	19.0	1 940	31 300	24.5	0.31	85.1	98.2	80.5	100.5	1	0.6	9	5S-2LA-HSL915U
5S-2LA-HSL916U	80	110	16	1	0.6	23.7	12.7	2 420	1 290	19.8	2 020	29 600	25.4	0.32	90.1	103.2	85.5	105.5	1	0.6	9	5S-2LA-HSL916U
5S-2LA-HSL917U	85	120	18	1.1	0.6	32.0	16.8	3 300	1 710	26.1	2 670	27 400	27.8	0.45	96.8	112.3	92	115.5	1	0.6	9	5S-2LA-HSL917U
5S-2LA-HSL918U	90	125	18	1.1	0.6	33.5	18.1	3 400	1 850	28.3	2 890	26 200	28.7	0.48	101.8	117.3	97	120.5	1	0.6	9	5S-2LA-HSL918U
5S-2LA-HSL919U	95	130	18	1.1	0.6	34.0	18.9	3 450	1 930	29.4	3 000	25 000	29.6	0.50	106.8	122.3	102	125.5	1	0.6	9	5S-2LA-HSL919U
5S-2LA-HSL920U	100	140	20	1.1	0.6	39.5	22.1	4 000	2 260	34.0	3 500	23 400	32.0	0.69	113.8	130.6	107	135.5	1	0.6	9	5S-2LA-HSL920U
5S-2LA-HSL921U	105	145	20	1.1	0.6	40.0	23.0	4 050	2 350	35.5	3 650	22 500	32.9	0.72	118.8	135.6	112	140.5	1	0.6	9	5S-2LA-HSL921U
5S-2LA-HSL922U	110	150	20	1.1	0.6	40.0	23.9	4 100	2 430	37.0	3 800	21 600	33.8	0.75	123.8	140.6	117	145.5	1	0.6	9	5S-2LA-HSL922U
5S-2LA-HSL924U	120	165	22	1.1	0.6	51.5	30.5	5 250	3 100	47.5	4 850	19 700	37.1	1.01	135.4	154.7	127	160.5	1	0.6	9	5S-2LA-HSL924U
5S-2LA-HSL926U	130	180	24	1.5	1	64.0	38.0	6 500	3 850	58.5	6 000	18 100	40.4	1.32	146.9	168.9	138.5	174.5	1.5	1	9	5S-2LA-HSL926U

1) Minimum allowable value for corner radius dimension *r* or *r*₁.
2) For the details of spacer dimensions, please contact NTN Engineering.

Angular Contact Ball Bearings for Radial Loads Dimension Tables



Dynamic equivalent radial load
 $P_r = X F_r + Y F_a$

<i>e</i>	Single row / Tandem				Back-to-back / Face-to-face			
	$F_a/F_r \leq e$		$F_a/F_r > e$		$F_a/F_r \leq e$		$F_a/F_r > e$	
	<i>X</i>	<i>Y</i>	<i>X</i>	<i>Y</i>	<i>X</i>	<i>Y</i>	<i>X</i>	<i>Y</i>
0.57	1	0	0.43	1	1	1.09	0.7	1.63

Static equivalent radial load
 $P_{0r} = X_0 F_r + Y_0 F_a$

Single row / Tandem		Back-to-back / Face-to-face	
<i>X</i> ₀	<i>Y</i> ₀	<i>X</i> ₀	<i>Y</i> ₀
0.5	0.42	1	0.84

When $P_{0r} < F_r$ with single-row or tandem arrangement, $P_{0r} = F_r$.

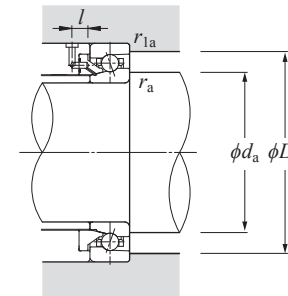

Angular Contact Ball Bearings for Radial Loads

ULTAGE Eco-friendly high speed angular contact ball bearings
(ceramic ball spec.)
5S-2LA-HSL9U type

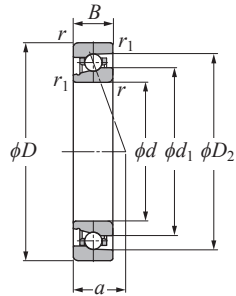

Contact angle 25° d 50–130 mm

Part number	Boundary dimensions					Basic load ratings				Allowable axial load		Allowable speed min ⁻¹ oil lubrication	Load center mm a	Mass kg Single-row (approx.)	Reference dimensions		Abutment and fillet dimensions					Part number
	mm					dynamic kN	static kN	dynamic kgf	static kgf	(static)	mm				d_1	D_2	mm					
	d	D	B	$r_{s \min}^{1)}$	$r_{1s \min}^{1)}$	C_r	C_{0r}	C_r	C_{0r}								d_a min	D_b max	r_{as} max	r_{1as} max	$l^{2)}$ min	
5S-2LA-HSL910UAD	50	72	12	0.6	0.3	11.4	5.30	1 170	545	9.75	995	41 000	20.3	0.11	57.6	66.7	54.5	69.5	0.6	0.3	8.5	5S-2LA-HSL910UAD
5S-2LA-HSL911UAD	55	80	13	1	0.6	14.3	6.65	1 450	680	12.1	1 240	37 000	22.4	0.16	63.6	74.1	60.5	75.5	1	0.6	8.5	5S-2LA-HSL911UAD
5S-2LA-HSL912UAD	60	85	13	1	0.6	14.8	7.25	1 510	740	13.3	1 360	34 500	23.5	0.17	68.6	79.0	65.5	80.5	1	0.6	8.5	5S-2LA-HSL912UAD
5S-2LA-HSL913UAD	65	90	13	1	0.6	14.9	7.60	1 520	775	13.9	1 420	32 300	24.7	0.17	73.6	84.0	70.5	85.5	1	0.6	8.5	5S-2LA-HSL913UAD
5S-2LA-HSL914UAD	70	100	16	1	0.6	21.9	10.8	2 230	1 100	19.9	2 030	29 400	28.0	0.29	80.1	93.2	75.5	95.5	1	0.6	8.5	5S-2LA-HSL914UAD
5S-2LA-HSL915UAD	75	105	16	1	0.6	22.7	11.8	2 310	1 200	21.5	2 200	27 800	29.1	0.31	85.1	98.2	80.5	100.5	1	0.6	9	5S-2LA-HSL915UAD
5S-2LA-HSL916UAD	80	110	16	1	0.6	23.0	12.3	2 340	1 250	22.5	2 300	26 300	30.3	0.32	90.1	103.2	85.5	105.5	1	0.6	9	5S-2LA-HSL916UAD
5S-2LA-HSL917UAD	85	120	18	1.1	0.6	31.0	16.2	3 150	1 660	29.4	3 000	24 400	33.1	0.45	96.8	112.3	92	115.5	1	0.6	9	5S-2LA-HSL917UAD
5S-2LA-HSL918UAD	90	125	18	1.1	0.6	32.5	17.6	3 300	1 790	31.5	3 250	23 300	34.2	0.48	101.8	117.3	97	120.5	1	0.6	9	5S-2LA-HSL918UAD
5S-2LA-HSL919UAD	95	130	18	1.1	0.6	32.5	18.3	3 350	1 870	33.0	3 400	22 200	35.4	0.50	106.8	122.3	102	125.5	1	0.6	9	5S-2LA-HSL919UAD
5S-2LA-HSL920UAD	100	140	20	1.1	0.6	38.0	21.4	3 850	2 190	39.0	4 000	20 800	38.2	0.69	113.8	130.6	107	135.5	1	0.6	9	5S-2LA-HSL920UAD
5S-2LA-HSL921UAD	105	145	20	1.1	0.6	38.5	22.3	3 900	2 270	40.5	4 150	20 000	39.3	0.72	118.8	135.6	112	140.5	1	0.6	9	5S-2LA-HSL921UAD
5S-2LA-HSL922UAD	110	150	20	1.1	0.6	39.0	23.1	3 950	2 360	42.0	4 300	19 200	40.5	0.75	123.8	140.6	117	145.5	1	0.6	9	5S-2LA-HSL922UAD
5S-2LA-HSL924UAD	120	165	22	1.1	0.6	50.0	29.6	5 100	3 000	54.0	5 550	17 500	44.4	1.01	135.4	154.7	127	160.5	1	0.6	9	5S-2LA-HSL924UAD
5S-2LA-HSL926UAD	130	180	24	1.5	1	61.5	36.5	6 300	3 750	67.0	6 850	16 100	48.4	1.32	146.9	168.8	138.5	174.5	1.5	1	9	5S-2LA-HSL926UAD

1) Minimum allowable value for corner radius dimension r or r_1 .
2) For the details of spacer dimensions, please contact NTN Engineering.

Angular Contact Ball Bearings for Radial Loads

Dynamic equivalent radial load
 $P_r = XF_r + YF_a$

e	Single row / Tandem				Back-to-back / Face-to-face			
	$F_a/F_r \leq e$		$F_a/F_r > e$		$F_a/F_r \leq e$		$F_a/F_r > e$	
	X	Y	X	Y	X	Y	X	Y
0.68	1	0	0.41	0.87	1	0.92	0.67	1.41

Static equivalent radial load
 $P_{0r} = X_0 F_r + Y_0 F_a$

Single row / Tandem		Back-to-back / Face-to-face	
X_0	Y_0	X_0	Y_0
0.5	0.38	1	0.76

When $P_{0r} < F_r$ with single-row or tandem arrangement, $P_{0r} = F_r$.

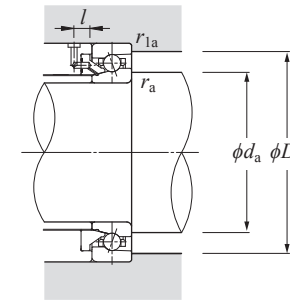

Angular Contact Ball Bearings for Radial Loads

Dimension Tables



ULTAGE Eco-friendly high speed angular contact ball bearings
(ceramic ball spec.)
5S-2LA-HSL0 type

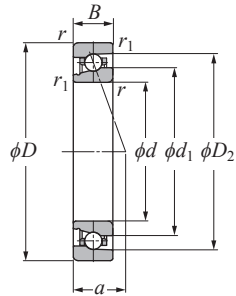

Contact angle 20° d 50–130 mm

Part number	Boundary dimensions					Basic load ratings				Allowable axial load		Allowable speed min ⁻¹ oil lubrication	Load center mm a	Mass kg Single-row (approx.)	Reference dimensions		Abutment and fillet dimensions					Part number
	mm					dynamic kN	static kN	dynamic kgf	static kgf	(static)					d_1	D_2	mm					
	d	D	B	r_s min ¹⁾	r_{1s} min ¹⁾	C_r	C_{0r}	C_r	C_{0r}						d_a min	D_b max	r_{as} max	r_{1as} max	l ²⁾ min			
5S-2LA-HSL010	50	80	16	1	0.6	17.2	7.8	1 750	790	12.1	1 230	43 300	19.9	0.22	60.1	73.2	55.5	75.5	1	0.6	8.5	5S-2LA-HSL010
5S-2LA-HSL011	55	90	18	1.1	0.6	18.7	9.2	1 900	935	14.4	1 460	38 800	22.3	0.35	67.6	80.8	62	85.5	1	0.6	8.5	5S-2LA-HSL011
5S-2LA-HSL012	60	95	18	1.1	0.6	19.5	10.2	1 990	1 040	15.9	1 620	36 300	23.2	0.38	72.6	85.8	67	90.5	1	0.6	8.5	5S-2LA-HSL012
5S-2LA-HSL013	65	100	18	1.1	0.6	19.8	10.7	2 020	1 090	16.7	1 710	34 100	24.1	0.40	77.6	90.8	72	95.5	1	0.6	9	5S-2LA-HSL013
5S-2LA-HSL014	70	110	20	1.1	0.6	24.2	13.5	2 470	1 370	21.1	2 150	31 200	26.5	0.57	84.8	99.1	77	105.5	1	0.6	9	5S-2LA-HSL014
5S-2LA-HSL015	75	115	20	1.1	0.6	25.8	15.2	2 630	1 550	23.8	2 420	29 600	27.4	0.60	89.8	104.1	82	110.5	1	0.6	9	5S-2LA-HSL015
5S-2LA-HSL016	80	125	22	1.1	0.6	29.6	17.4	3 000	1 770	27.2	2 780	27 400	29.8	0.82	96.8	112.5	87	120.5	1	0.6	9	5S-2LA-HSL016
5S-2LA-HSL017	85	130	22	1.1	0.6	30.0	18.1	3 050	1 850	28.4	2 900	26 200	30.7	0.85	101.8	117.4	92	125.5	1	0.6	9	5S-2LA-HSL017
5S-2LA-HSL018	90	140	24	1.5	1	34.5	21.3	3 550	2 170	33.5	3 400	24 500	33.1	1.12	108.8	125.8	98.5	134.5	1.5	1	9	5S-2LA-HSL018
5S-2LA-HSL019	95	145	24	1.5	1	35.0	22.1	3 600	2 260	34.5	3 550	23 400	34.0	1.17	113.8	130.8	103.5	139.5	1.5	1	9	5S-2LA-HSL019
5S-2LA-HSL020	100	150	24	1.5	1	36.5	23.8	3 700	2 420	37.5	3 800	22 500	34.9	1.22	118.8	135.8	108.5	144.5	1.5	1	9	5S-2LA-HSL020
5S-2LA-HSL021	105	160	26	2	1	42.0	27.5	4 250	2 810	43.0	4 400	21 200	37.3	1.55	125.8	144.1	115	154.5	2	1	9	5S-2LA-HSL021
5S-2LA-HSL022	110	170	28	2	1	51.5	33.5	5 300	3 400	52.0	5 300	20 100	39.7	1.89	132.4	153.2	120	164.5	2	1	9	5S-2LA-HSL022
5S-2LA-HSL024	120	180	28	2	1	52.0	35.0	5 300	3 550	54.5	5 550	18 700	41.5	2.03	142.4	163.2	130	174.5	2	1	9	5S-2LA-HSL024
5S-2LA-HSL026	130	200	33	2	1	74.5	48.0	7 600	4 900	75.5	7 700	17 000	46.8	2.98	155.5	181.5	140	194.5	2	1	9	5S-2LA-HSL026

1) Minimum allowable value for corner radius dimension r or r_1 .
2) For the details of spacer dimensions, please contact NTN Engineering.

Angular Contact Ball Bearings for Radial Loads

Dimension Tables



Dynamic equivalent radial load
 $P_r = X F_r + Y F_a$

e	Single row / Tandem				Back-to-back / Face-to-face			
	$F_a/F_r \leq e$		$F_a/F_r > e$		$F_a/F_r \leq e$		$F_a/F_r > e$	
	X	Y	X	Y	X	Y	X	Y
0.57	1	0	0.43	1	1	1.09	0.7	1.63

Static equivalent radial load
 $P_{0r} = X_0 F_r + Y_0 F_a$

Single row / Tandem		Back-to-back / Face-to-face	
X_0	Y_0	X_0	Y_0
0.5	0.42	1	0.84

When $P_{0r} < F_r$ with single-row or tandem arrangement, $P_{0r} = F_r$.

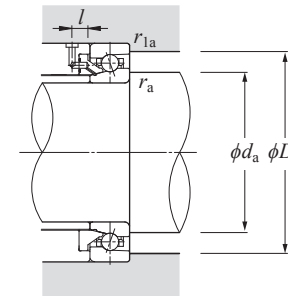

Angular Contact Ball Bearings for Radial Loads

ULTAGE Eco-friendly high speed angular contact ball bearings
(ceramic ball spec.)
5S-2LA-HSL0 type

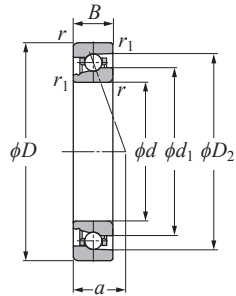

Contact angle 25° d 50–130 mm

Part number	Boundary dimensions					Basic load ratings				Allowable axial load		Allowable speed	Load center mm	Mass kg	Reference dimensions		Abutment and fillet dimensions					Part number
	mm					dynamic kN	static kN	dynamic kgf	static kgf	kN	kgf	min ⁻¹			mm		mm					
	d	D	B	$r_s \text{ min}^{(1)}$	$r_{1s} \text{ min}^{(1)}$	C_r	C_{0r}	C_r	C_{0r}	(static)	oil lubrication	a			d_1	D_2	$d_a \text{ min}$	$D_b \text{ max}$	$r_{as} \text{ max}$	$r_{1as} \text{ max}$	$l^{(2)}$	
5S-2LA-HSL010AD	50	80	16	1	0.6	16.6	7.50	1 700	765	13.8	1 400	38 500	23.3	0.22	60.1	73.2	55.5	75.5	1	0.6	8.5	5S-2LA-HSL010AD
5S-2LA-HSL011AD	55	90	18	1.1	0.6	18.1	8.90	1 840	910	16.4	1 670	34 500	26.1	0.35	67.6	80.8	62	85.5	1	0.6	8.5	5S-2LA-HSL011AD
5S-2LA-HSL012AD	60	95	18	1.1	0.6	18.9	9.85	1 930	1 000	18.1	1 850	32 300	27.2	0.38	72.6	85.8	67	90.5	1	0.6	8.5	5S-2LA-HSL012AD
5S-2LA-HSL013AD	65	100	18	1.1	0.6	19.2	10.4	1 960	1 060	19.0	1 940	30 300	28.4	0.40	77.6	90.8	72	95.5	1	0.6	9	5S-2LA-HSL013AD
5S-2LA-HSL014AD	70	110	20	1.1	0.6	23.4	13.0	2 390	1 330	24.0	2 440	27 800	31.1	0.57	84.8	99.1	77	105.5	1	0.6	9	5S-2LA-HSL014AD
5S-2LA-HSL015AD	75	115	20	1.1	0.6	25.0	14.7	2 550	1 500	27.0	2 760	26 300	32.3	0.60	89.8	104.1	82	110.5	1	0.6	9	5S-2LA-HSL015AD
5S-2LA-HSL016AD	80	125	22	1.1	0.6	28.6	16.9	2 910	1 720	31.0	3 150	24 400	35.1	0.82	96.8	112.5	87	120.5	1	0.6	9	5S-2LA-HSL016AD
5S-2LA-HSL017AD	85	130	22	1.1	0.6	28.9	17.6	2 950	1 790	32.5	3 300	23 300	36.2	0.85	101.8	117.4	92	125.5	1	0.6	9	5S-2LA-HSL017AD
5S-2LA-HSL018AD	90	140	24	1.5	1	33.5	20.6	3 400	2 100	38.0	3 850	21 700	39.0	1.12	108.8	125.8	98.5	134.5	1.5	1	9	5S-2LA-HSL018AD
5S-2LA-HSL019AD	95	145	24	1.5	1	34.0	21.4	3 450	2 190	39.5	4 000	20 800	40.2	1.17	113.8	130.8	103.5	139.5	1.5	1	9	5S-2LA-HSL019AD
5S-2LA-HSL020AD	100	150	24	1.5	1	35.0	23.0	3 600	2 350	42.5	4 300	20 000	41.3	1.22	118.8	135.8	108.5	144.5	1.5	1	9	5S-2LA-HSL020AD
5S-2LA-HSL021AD	105	160	26	2	1	40.5	26.7	4 100	2 720	49.0	5 000	18 900	44.1	1.55	125.8	144.1	115	154.5	2	1	9	5S-2LA-HSL021AD
5S-2LA-HSL022AD	110	170	28	2	1	50.0	32.5	5 100	3 300	59.5	6 050	17 700	46.9	1.89	132.4	153.2	120	164.5	2	1	9	5S-2LA-HSL022AD
5S-2LA-HSL024AD	120	180	28	2	1	50.5	33.5	5 150	3 450	62.0	6 300	16 700	49.2	2.03	142.4	163.2	130	174.5	2	1	9	5S-2LA-HSL024AD
5S-2LA-HSL026AD	130	200	33	2	1	72.5	46.5	7 350	4 750	85.5	8 750	15 200	55.3	2.98	155.5	181.5	140	194.5	2	1	9	5S-2LA-HSL026AD

1) Minimum allowable value for corner radius dimension r or r_1 .
2) For the details of spacer dimensions, please contact **NTN Engineering**.

Angular Contact Ball Bearings for Radial Loads

Dynamic equivalent radial load
 $P_r = X F_r + Y F_a$

e	Single row / Tandem				Back-to-back / Face-to-face			
	$F_a/F_r \leq e$		$F_a/F_r > e$		$F_a/F_r \leq e$		$F_a/F_r > e$	
	X	Y	X	Y	X	Y	X	Y
0.68	1	0	0.41	0.87	1	0.92	0.67	1.41

Static equivalent radial load
 $P_{0r} = X_0 F_r + Y_0 F_a$

Single row / Tandem		Back-to-back / Face-to-face	
X_0	Y_0	X_0	Y_0
0.5	0.38	1	0.76

When $P_{0r} < F_r$ with single-row or tandem arrangement, $P_{0r} = F_r$.

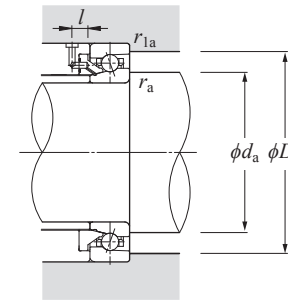

Main Spindle Bearings

Main Spindle Bearings

Angular Contact Ball Bearings for Radial Loads Dimension Tables



ULTAGE Eco-friendly ultra high speed angular contact ball bearings
(ceramic ball spec.)
5S-2LA-HSFL0 type

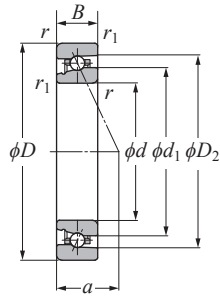

Contact angle 25° d 50–100 mm

Part number	Boundary dimensions						Basic load ratings				Allowable axial load		Allowable speed min ⁻¹ oil lubrication	Load center mm <i>a</i>	Mass kg Single-row (approx.)	Reference dimensions		Abutment and fillet dimensions					Part number
	mm						dynamic kN	static kN	dynamic kgf	static kgf	(static)	mm				<i>d</i> ₁	<i>D</i> ₂	mm					
	<i>d</i>	<i>D</i>	<i>B</i>	<i>r</i> _{s min¹⁾}	<i>r</i> _{1s min¹⁾}	<i>C</i> _r	<i>C</i> _{0r}	<i>C</i> _r	<i>C</i> _{0r}	<i>d</i> _a min								<i>D</i> _b max	<i>r</i> _{as} max	<i>r</i> _{1as} max	<i>l</i> ²⁾ min		
5S-2LA-HSFL010AD	50	80	16	1	0.6	11.1	6.20	1 140	635	11.4	1 170	50 000	23.3	0.27	61.6	70.9	55.5	75.5	1	0.6	8.5	5S-2LA-HSFL010AD	
5S-2LA-HSFL011AD	55	90	18	1.1	0.6	13.9	7.80	1 420	800	14.4	1 470	44 800	26.0	0.40	68.6	79.2	62	85.5	1	0.6	8.5	5S-2LA-HSFL011AD	
5S-2LA-HSFL012AD	60	95	18	1.1	0.6	14.3	8.45	1 460	860	15.5	1 580	41 900	27.2	0.43	73.6	84.2	67	90.5	1	0.6	8.5	5S-2LA-HSFL012AD	
5S-2LA-HSFL013AD	65	100	18	1.1	0.6	14.7	9.05	1 500	925	16.7	1 700	39 400	28.3	0.46	78.6	89.2	72	95.5	1	0.6	9	5S-2LA-HSFL013AD	
5S-2LA-HSFL014AD	70	110	20	1.1	0.6	18.0	11.1	1 830	1 130	20.4	2 080	36 100	31.1	0.64	85.6	97.5	77	105.5	1	0.6	9	5S-2LA-HSFL014AD	
5S-2LA-HSFL015AD	75	115	20	1.1	0.6	18.5	11.9	1 880	1 210	21.8	2 220	34 200	32.3	0.68	90.6	102.5	82	110.5	1	0.6	9	5S-2LA-HSFL015AD	
5S-2LA-HSFL016AD	80	125	22	1.1	0.6	22.0	14.2	2 250	1 440	26.0	2 660	31 700	35.0	0.91	97.6	110.8	87	120.5	1	0.6	9	5S-2LA-HSFL016AD	
5S-2LA-HSFL017AD	85	130	22	1.1	0.6	22.2	14.7	2 270	1 500	27.0	2 750	30 200	36.2	0.95	102.6	115.8	92	125.5	1	0.6	9	5S-2LA-HSFL017AD	
5S-2LA-HSFL018AD	90	140	24	1.5	1	27.1	18.2	2 760	1 860	33.5	3 400	28 300	39.0	1.25	109.8	124.2	98.5	134.5	1.5	1	9	5S-2LA-HSFL018AD	
5S-2LA-HSFL019AD	95	145	24	1.5	1	27.3	18.8	2 790	1 920	34.5	3 550	27 100	40.1	1.30	114.8	129.2	103.5	139.5	1.5	1	9	5S-2LA-HSFL019AD	
5S-2LA-HSFL020AD	100	150	24	1.5	1	28.1	20.0	2 860	2 040	37.0	3 750	26 000	41.3	1.36	119.8	134.2	108.5	144.5	1.5	1	9	5S-2LA-HSFL020AD	

1) Minimum allowable value for corner radius dimension *r* or *r*₁.
2) For the details of spacer dimensions, please contact NTN Engineering.

Angular Contact Ball Bearings for Radial Loads Dimension Tables



Dynamic equivalent radial load
 $P_r = X F_r + Y F_a$

<i>e</i>	Single row / Tandem				Back-to-back / Face-to-face			
	$F_a/F_r \leq e$		$F_a/F_r > e$		$F_a/F_r \leq e$		$F_a/F_r > e$	
	<i>X</i>	<i>Y</i>	<i>X</i>	<i>Y</i>	<i>X</i>	<i>Y</i>	<i>X</i>	<i>Y</i>
0.68	1	0	0.41	0.87	1	0.92	0.67	1.41

Static equivalent radial load
 $P_{0r} = X_0 F_r + Y_0 F_a$

Single row / Tandem		Back-to-back / Face-to-face	
<i>X</i> ₀	<i>Y</i> ₀	<i>X</i> ₀	<i>Y</i> ₀
0.5	0.38	1	0.76

When $P_{0r} < F_r$ with single-row or tandem arrangement, $P_{0r} = F_r$.

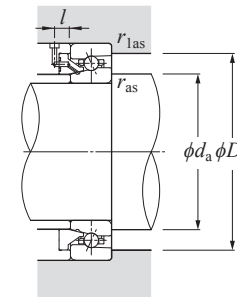

Angular Contact Ball Bearings for Radial Loads

Dimension Tables



ULTAGE Air-oil lubricated high speed angular contact ball bearings with re-lubricating hole on the outer ring (ceramic ball spec.)
5S-2LA-HSEW9U type

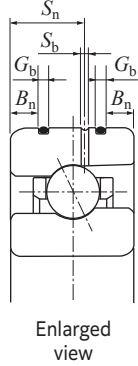
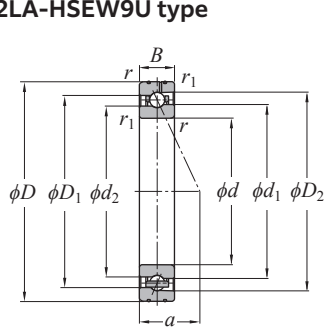

Contact angle 20° d 50–100 mm

Part number	Boundary dimensions										Basic load ratings				Allowable axial load		Allowable speed oil lubrication	Load center mm <i>a</i>	Mass kg Single-row (approx.)	Reference dimensions				Abutment and fillet dimensions					
	mm										dynamic	static	dynamic	static	kN	kgf				mm				mm					
	<i>d</i>	<i>D</i>	<i>B</i>	<i>B_n</i>	<i>S_n</i>	<i>S_b</i>	<i>G_b</i>	<i>r_s</i> min ⁻¹	<i>r_{ls}</i> min ⁻¹	<i>C_r</i>	<i>C_{0r}</i>	<i>C_r</i>	<i>C_{0r}</i>	(static)						<i>d₁</i>	<i>d₂</i>	<i>D₁</i>	<i>D₂</i>	<i>d_a</i> min	<i>d_b</i> min	<i>D_a</i> max	<i>D_b</i> max	<i>r_{as}</i> max	<i>r_{1as}</i> max
5S-2LA-HSEW910U	50	72	12	2.2	6.6	1.2	1.3	0.6	0.3	11.8	5.50	1 210	560	8.55	875	46 100	17.2	0.12	57.6	56.6	64.4	66.8	54.5	52.5	67.5	69.5	0.6	0.3	
5S-2LA-HSEW911U	55	80	13	2.8	7.2	1.2	1.3	1	0.6	14.7	6.85	1 500	700	10.6	1 090	41 700	18.9	0.17	63.6	62.4	71.4	74.1	60.5	59.5	74.5	75.5	1	0.6	
5S-2LA-HSEW912U	60	85	13	2.8	7.2	1.2	1.3	1	0.6	15.3	7.50	1 560	765	11.6	1 190	38 800	19.8	0.18	68.6	67.4	76.4	79.1	65.5	64.5	79.5	80.5	1	0.6	
5S-2LA-HSEW913U	65	90	13	2.8	7.2	1.2	1.3	1	0.6	15.4	7.85	1 570	800	12.2	1 250	36 300	20.7	0.19	73.6	72.4	81.4	84.0	70.5	69.5	84.5	85.5	1	0.6	
5S-2LA-HSEW914U	70	100	16	3.1	9.3	1.4	1.9	1	0.6	22.6	11.2	2 310	1 140	17.4	1 780	33 100	23.6	0.31	80.1	78.6	89.8	93.2	75.5	74.5	94.5	95.5	1	0.6	
5S-2LA-HSEW915U	75	105	16	3.1	9.3	1.4	1.9	1	0.6	23.5	12.2	2 390	1 240	19.0	1 940	31 300	24.5	0.33	85.1	83.6	94.8	98.2	80.5	79.5	99.5	100.5	1	0.6	
5S-2LA-HSEW916U	80	110	16	3.1	9.3	1.4	1.9	1	0.6	23.7	12.7	2 420	1 290	19.8	2 020	29 600	25.4	0.34	90.1	88.6	99.8	103.2	85.5	84.5	104.5	105.5	1	0.6	
5S-2LA-HSEW917U	85	120	18	4	10.4	1.6	1.9	1.1	0.6	32.0	16.8	3 300	1 710	26.1	2 670	27 400	27.8	0.48	96.8	94.9	108.2	112.3	92	89.5	113	115.5	1	0.6	
5S-2LA-HSEW918U	90	125	18	4	10.4	1.6	1.9	1.1	0.6	33.5	18.1	3 400	1 850	28.3	2 890	26 200	28.7	0.51	101.8	99.9	113.2	117.3	97	94.5	118	120.5	1	0.6	
5S-2LA-HSEW919U	95	130	18	4	10.4	1.6	1.9	1.1	0.6	34.0	18.9	3 450	1 930	29.4	3 000	25 000	29.6	0.53	106.8	104.9	118.2	122.3	102	99.5	123	125.5	1	0.6	
5S-2LA-HSEW920U	100	140	20	4	12	1.6	1.9	1.1	0.6	39.5	22.1	4 000	2 260	34.0	3 500	23 400	32.0	0.74	113.8	111.7	126.2	130.6	107	104.5	133	135.5	1	0.6	

1) Minimum allowable value for corner radius dimension *r* or *r₁*.

Angular Contact Ball Bearings for Radial Loads

Dimension Tables



Dynamic equivalent radial load
 $P_r = X F_r + Y F_a$

<i>e</i>	Single row / Tandem				Back-to-back / Face-to-face			
	$F_a/F_r \leq e$		$F_a/F_r > e$		$F_a/F_r \leq e$		$F_a/F_r > e$	
	<i>X</i>	<i>Y</i>	<i>X</i>	<i>Y</i>	<i>X</i>	<i>Y</i>	<i>X</i>	<i>Y</i>
0.57	1	0	0.43	1	1	1.09	0.7	1.63

Static equivalent radial load
 $P_{0r} = X_0 F_r + Y_0 F_a$

Single row / Tandem		Back-to-back / Face-to-face	
<i>X₀</i>	<i>Y₀</i>	<i>X₀</i>	<i>Y₀</i>
0.5	0.42	1	0.84

When $P_{0r} < F_r$ with single-row or tandem arrangement, $P_{0r} = F_r$.

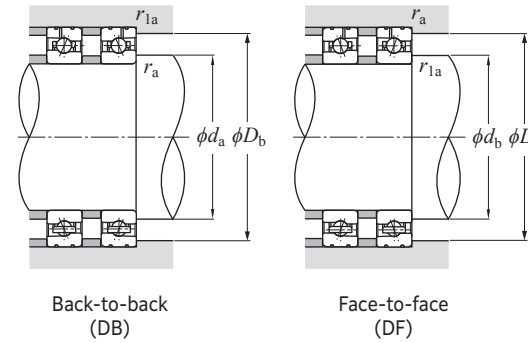

Angular Contact Ball Bearings for Radial Loads

Dimension Tables



ULTAGE Air-oil lubricated high speed angular contact ball bearings with re-lubricating hole on the outer ring (ceramic ball spec.)
5S-2LA-HSEW9U type

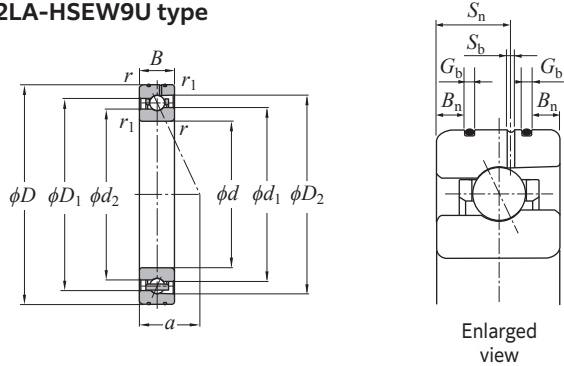

Enlarged view

Contact angle 25° d 50–100 mm

Part number	Boundary dimensions										Basic load ratings				Allowable axial load		Allowable speed oil lubrication min ⁻¹	Load center mm <i>a</i>	Mass kg Single-row (approx.)	Reference dimensions				Abutment and fillet dimensions					
	mm										dynamic kN	static kgf	dynamic kN	static kgf	(static) kN	kgf				mm				mm					
	<i>d</i>	<i>D</i>	<i>B</i>	<i>B_n</i>	<i>S_n</i>	<i>S_b</i>	<i>G_b</i>	<i>r_{s min}</i> ¹⁾	<i>r_{1s min}</i> ¹⁾	<i>C_r</i>	<i>C_{0r}</i>	<i>C_r</i>	<i>C_{0r}</i>	<i>d_{a min}</i>						<i>d_{b min}</i>	<i>D_{a max}</i>	<i>D_{b max}</i>	<i>r_{as max}</i>	<i>r_{1as max}</i>					
5S-2LA-HSEW910UAD	50	72	12	2.2	6.6	1.2	1.3	0.6	0.3	11.4	5.30	1 170	545	9.75	995	41 000	20.3	0.12	57.6	56.6	64.4	66.7	54.5	52.5	67.5	69.5	0.6	0.3	
5S-2LA-HSEW911UAD	55	80	13	2.8	7.2	1.2	1.3	1	0.6	14.3	6.65	1 450	680	12.1	1 240	37 000	22.4	0.17	63.6	62.4	71.4	74.1	60.5	59.5	74.5	75.5	1	0.6	
5S-2LA-HSEW912UAD	60	85	13	2.8	7.2	1.2	1.3	1	0.6	14.8	7.25	1 510	740	13.3	1 360	34 500	23.5	0.18	68.6	67.4	76.4	79.0	65.5	64.5	79.5	80.5	1	0.6	
5S-2LA-HSEW913UAD	65	90	13	2.8	7.2	1.2	1.3	1	0.6	14.9	7.60	1 520	775	13.9	1 420	32 300	24.7	0.19	73.6	72.4	81.4	84.0	70.5	69.5	84.5	85.5	1	0.6	
5S-2LA-HSEW914UAD	70	100	16	3.1	9.3	1.4	1.9	1	0.6	21.9	10.8	2 230	1 100	19.9	2 030	29 400	28.0	0.31	80.1	78.6	89.8	93.2	75.5	74.5	94.5	95.5	1	0.6	
5S-2LA-HSEW915UAD	75	105	16	3.1	9.3	1.4	1.9	1	0.6	22.7	11.8	2 310	1 200	21.5	2 200	27 800	29.1	0.33	85.1	83.6	94.8	98.2	80.5	79.5	99.5	100.5	1	0.6	
5S-2LA-HSEW916UAD	80	110	16	3.1	9.3	1.4	1.9	1	0.6	23.0	12.3	2 340	1 250	22.5	2 300	26 300	30.3	0.34	90.1	88.6	99.8	103.2	85.5	84.5	104.5	105.5	1	0.6	
5S-2LA-HSEW917UAD	85	120	18	4	10.4	1.6	1.9	1.1	0.6	31.0	16.2	3 150	1 660	29.4	3 000	24 400	33.1	0.48	96.8	94.9	108.2	112.3	92	89.5	113	115.5	1	0.6	
5S-2LA-HSEW918UAD	90	125	18	4	10.4	1.6	1.9	1.1	0.6	32.5	17.6	3 300	1 790	31.5	3 250	23 300	34.2	0.51	101.8	99.9	113.2	117.3	97	94.5	118	120.5	1	0.6	
5S-2LA-HSEW919UAD	95	130	18	4	10.4	1.6	1.9	1.1	0.6	32.5	18.3	3 350	1 870	33.0	3 400	22 200	35.4	0.53	106.8	104.9	118.2	122.3	102	99.5	123	125.5	1	0.6	
5S-2LA-HSEW920UAD	100	140	20	4	12	1.6	1.9	1.1	0.6	38.0	21.4	3 850	2 190	39.0	4 000	20 800	38.2	0.74	113.8	111.7	126.2	130.6	107	104.5	133	135.5	1	0.6	

1) Minimum allowable value for corner radius dimension *r* or *r₁*.

Angular Contact Ball Bearings for Radial Loads

Dimension Tables



Dynamic equivalent radial load
 $P_r = X F_r + Y F_a$

<i>e</i>	Single row / Tandem				Back-to-back / Face-to-face			
	$F_a/F_r \leq e$		$F_a/F_r > e$		$F_a/F_r \leq e$		$F_a/F_r > e$	
	<i>X</i>	<i>Y</i>	<i>X</i>	<i>Y</i>	<i>X</i>	<i>Y</i>	<i>X</i>	<i>Y</i>
0.68	1	0	0.41	0.87	1	0.92	0.67	1.41

Static equivalent radial load
 $P_{0r} = X_0 F_r + Y_0 F_a$

Single row / Tandem		Back-to-back / Face-to-face	
<i>X₀</i>	<i>Y₀</i>	<i>X₀</i>	<i>Y₀</i>
0.5	0.38	1	0.76

When $P_{0r} < F_r$ with single-row or tandem arrangement, $P_{0r} = F_r$.

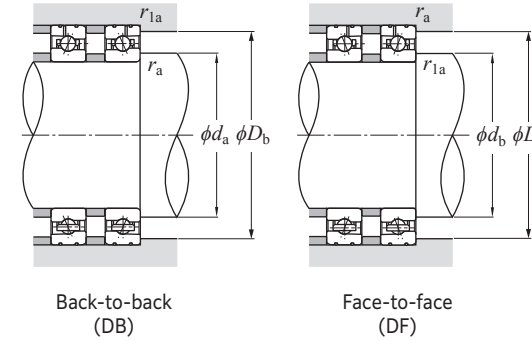

Back-to-back (DB)

Face-to-face (DF)

Angular Contact Ball Bearings for Radial Loads

Dimension Tables



ULTAGE Air-oil lubricated high speed angular contact ball bearings with re-lubricating hole on the outer ring (ceramic ball spec.)
5S-2LA-HSEW0 type

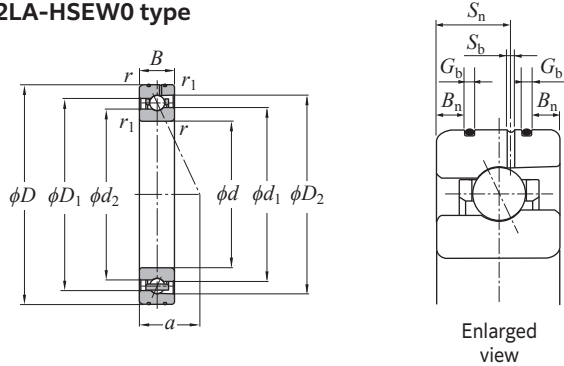

Contact angle 20° d 50–100 mm

Part number	Boundary dimensions										Basic load ratings				Allowable axial load		Allowable speed oil lubrication	Load center mm a	Mass kg Single-row (approx.)	Reference dimensions				Abutment and fillet dimensions					
	mm										dynamic kN	static kgf	dynamic kN	static kgf	mm					mm									
	d	D	B	B_n	S_n	S_b	G_b	$r_{s\min}^{(1)}$	$r_{1s\min}^{(1)}$	C_r	C_{0r}	C_r	C_{0r}	(static)	d_1	d_2				D_1	D_2	d_a min	d_b min	D_a max	D_b max	r_{as} max	r_{1as} max		
5S-2LA-HSEW010	50	80	16	3.4	9.3	1.4	1.3	1	0.6	17.2	7.75	1750	790	12.1	1230	43	300	19.9	0.23	60.1	58.6	69.9	73.2	55.5	54.5	74.5	75.5	1	0.6
5S-2LA-HSEW011	55	90	18	4.3	9.7	1.4	1.9	1.1	0.6	18.7	9.20	1900	935	14.4	1460	38	800	22.3	0.37	67.6	66.2	77.4	80.8	62	59.5	83	85.5	1	0.6
5S-2LA-HSEW012	60	95	18	4.3	9.7	1.4	1.9	1.1	0.6	19.5	10.2	1990	1040	15.9	1620	36	300	23.2	0.40	72.6	71.2	82.4	85.8	67	64.5	88	90.5	1	0.6
5S-2LA-HSEW013	65	100	18	4	10.4	1.6	1.9	1.1	0.6	19.8	10.7	2020	1090	16.7	1710	34	100	24.1	0.42	77.6	76.2	87.4	90.8	72	69.5	93	95.5	1	0.6
5S-2LA-HSEW014	70	110	20	4	11.6	1.6	1.9	1.1	0.6	24.2	13.5	2470	1370	21.1	2150	31	200	26.5	0.60	84.8	83.0	95.2	99.1	77	74.5	103	105.5	1	0.6
5S-2LA-HSEW015	75	115	20	4	11.6	1.6	2.4	1.1	0.6	25.8	15.2	2630	1550	23.8	2420	29	600	27.4	0.64	89.8	88.0	100.2	104.1	82	79.5	108	110.5	1	0.6
5S-2LA-HSEW016	80	125	22	4.7	12.2	1.6	2.4	1.1	0.6	29.6	17.4	3000	1770	27.2	2780	27	400	29.8	0.86	96.8	94.9	108.2	112.5	87	84.5	118	120.5	1	0.6
5S-2LA-HSEW017	85	130	22	4.7	12.2	1.6	2.4	1.1	0.6	30.0	18.1	3050	1850	28.4	2900	26	200	30.7	0.90	101.8	99.9	113.2	117.4	92	89.5	123	125.5	1	0.6
5S-2LA-HSEW018	90	140	24	5.5	14.5	1.6	1.9	1.5	1	34.5	21.3	3550	2170	33.5	3400	24	500	33.1	1.18	108.8	106.7	121.2	125.8	98.5	95.5	131.5	134.5	1.5	1
5S-2LA-HSEW019	95	145	24	5.5	14.5	1.6	2.4	1.5	1	35.0	22.1	3600	2260	34.5	3550	23	400	34.0	1.23	113.8	111.7	126.2	130.8	103.5	100.5	136.5	139.5	1.5	1
5S-2LA-HSEW020	100	150	24	5.5	14.5	1.6	1.9	1.5	1	36.5	23.8	3700	2420	37.5	3800	22	500	34.9	1.28	118.8	116.7	131.2	135.8	108.5	105.5	141.5	144.5	1.5	1

1) Minimum allowable value for corner radius dimension r or r_1 .

Angular Contact Ball Bearings for Radial Loads

Dimension Tables



Dynamic equivalent radial load
 $P_r = XF_r + YF_a$

e	Single row / Tandem				Back-to-back / Face-to-face			
	$F_a/F_r \leq e$		$F_a/F_r > e$		$F_a/F_r \leq e$		$F_a/F_r > e$	
	X	Y	X	Y	X	Y	X	Y
0.57	1	0	0.43	1	1	1.09	0.7	1.63

Static equivalent radial load
 $P_{0r} = X_0 F_r + Y_0 F_a$

Single row / Tandem		Back-to-back / Face-to-face	
X_0	Y_0	X_0	Y_0
0.5	0.42	1	0.84

When $P_{0r} < F_r$ with single-row or tandem arrangement, $P_{0r} = F_r$.

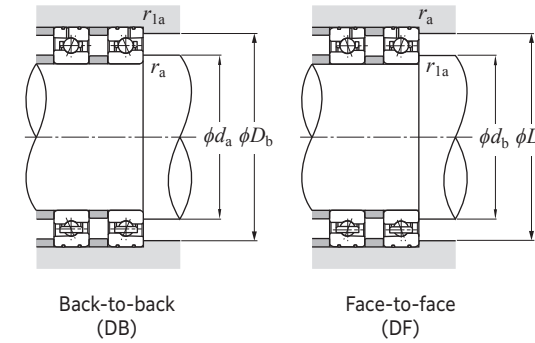

Angular Contact Ball Bearings for Radial Loads

Dimension Tables



ULTAGE Air-oil lubricated high speed angular contact ball bearings with re-lubricating hole on the outer ring (ceramic ball spec.)
5S-2LA-HSEW0 type

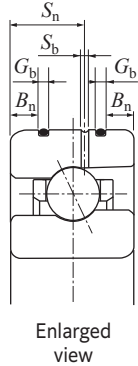
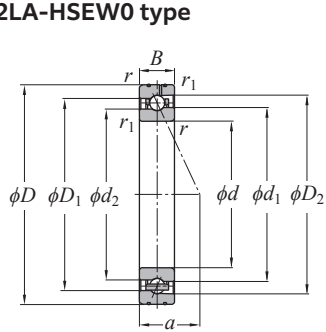

Contact angle 25° d 50–100 mm

Part number	Boundary dimensions										Basic load ratings				Allowable axial load		Allowable speed oil lubrication min ⁻¹	Load center mm <i>a</i>	Mass kg Single-row (approx.)	Reference dimensions				Abutment and fillet dimensions					
	mm										dynamic kN	static kgf	dynamic kN	static kgf	(static) kN	kgf				mm				mm					
	<i>d</i>	<i>D</i>	<i>B</i>	<i>B_n</i>	<i>S_n</i>	<i>S_b</i>	<i>G_b</i>	<i>r_s</i> min ¹⁾	<i>r_{1s}</i> min ¹⁾	<i>C_r</i>	<i>C_{Or}</i>	<i>C_r</i>	<i>C_{Or}</i>					<i>d₁</i>	<i>d₂</i>	<i>D₁</i>	<i>D₂</i>	<i>d_a</i> min	<i>d_b</i> min	<i>D_a</i> max	<i>D_b</i> max	<i>r_{as}</i> max	<i>r_{1as}</i> max		
5S-2LA-HSEW010AD	50	80	16	3.4	9.3	1.4	1.3	1	0.6	16.6	7.50	1700	765	13.8	1400	38 500	23.3	0.23	60.1	58.6	69.9	73.2	55.5	54.5	74.5	75.5	1	0.6	
5S-2LA-HSEW011AD	55	90	18	4.3	9.7	1.4	1.9	1.1	0.6	18.1	8.90	1840	910	16.4	1670	34 500	26.1	0.37	67.6	66.2	77.4	80.8	62	59.5	83	85.5	1	0.6	
5S-2LA-HSEW012AD	60	95	18	4.3	9.7	1.4	1.9	1.1	0.6	18.9	9.85	1930	1000	18.1	1850	32 300	27.2	0.40	72.6	71.2	82.4	85.8	67	64.5	88	90.5	1	0.6	
5S-2LA-HSEW013AD	65	100	18	4	10.4	1.6	1.9	1.1	0.6	19.2	10.4	1960	1060	19.0	1940	30 300	28.4	0.40	77.6	76.2	87.4	90.8	72	69.5	93	95.5	1	0.6	
5S-2LA-HSEW014AD	70	110	20	4	11.6	1.6	1.9	1.1	0.6	23.4	13.0	2390	1330	24.0	2440	27 800	31.1	0.60	84.8	83.0	95.2	99.1	77	74.5	103	105.5	1	0.6	
5S-2LA-HSEW015AD	75	115	20	4	11.6	1.6	2.4	1.1	0.6	25.0	14.7	2550	1500	27.0	2760	26 300	32.3	0.64	89.8	88.0	100.2	104.1	82	79.5	108	110.5	1	0.6	
5S-2LA-HSEW016AD	80	125	22	4.7	12.2	1.6	2.4	1.1	0.6	28.6	16.9	2910	1720	31.0	3150	24 400	35.1	0.86	96.8	94.9	108.2	112.5	87	84.5	118	120.5	1	0.6	
5S-2LA-HSEW017AD	85	130	22	4.7	12.2	1.6	2.4	1.1	0.6	28.9	17.6	2950	1790	32.5	3300	23 300	36.2	0.90	101.8	99.9	113.2	117.4	92	89.5	123	125.5	1	0.6	
5S-2LA-HSEW018AD	90	140	24	5.5	14.5	1.6	1.9	1.5	1	33.5	20.6	3400	2100	38.0	3850	21 700	39.0	1.18	108.8	106.7	121.2	125.8	98.5	95.5	131.5	134.5	1.5	1	
5S-2LA-HSEW019AD	95	145	24	5.5	14.5	1.6	2.4	1.5	1	34.0	21.4	3450	2190	39.5	4000	20 800	40.2	1.23	113.8	111.7	126.2	130.8	103.5	100.5	136.5	139.5	1.5	1	
5S-2LA-HSEW020AD	100	150	24	5.5	14.5	1.6	1.9	1.5	1	35.0	23.0	3600	2350	42.5	4300	20 000	41.3	1.28	118.8	116.7	131.2	135.8	108.5	105.5	141.5	144.5	1.5	1	

1) Minimum allowable value for corner radius dimension *r* or *r₁*.

Angular Contact Ball Bearings for Radial Loads

Dimension Tables



Dynamic equivalent radial load
 $P_r = X F_r + Y F_a$

<i>e</i>	Single row / Tandem				Back-to-back / Face-to-face			
	$F_a/F_r \leq e$		$F_a/F_r > e$		$F_a/F_r \leq e$		$F_a/F_r > e$	
	<i>X</i>	<i>Y</i>	<i>X</i>	<i>Y</i>	<i>X</i>	<i>Y</i>	<i>X</i>	<i>Y</i>
0.68	1	0	0.41	0.87	1	0.92	0.67	1.41

Static equivalent radial load
 $P_{0r} = X_0 F_r + Y_0 F_a$

Single row / Tandem		Back-to-back / Face-to-face	
<i>X₀</i>	<i>Y₀</i>	<i>X₀</i>	<i>Y₀</i>
0.5	0.38	1	0.76

When $P_{0r} < F_r$ with single-row or tandem arrangement, $P_{0r} = F_r$.

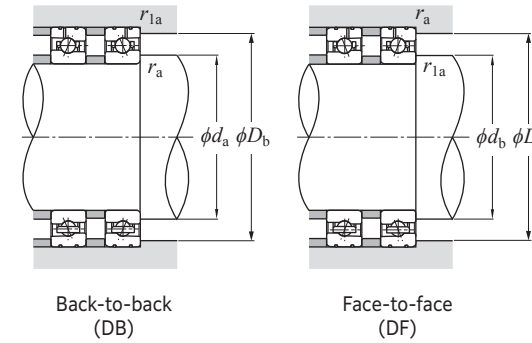

Angular Contact Ball Bearings for Radial Loads

Dimension Tables



ULTAGE Grease-lubricated sealed standard angular contact ball bearings (steel ball spec.)
79 LLB type

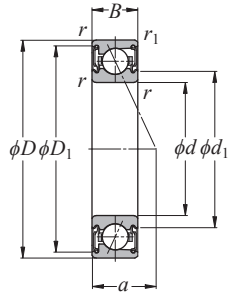

Contact angle 15° d 10–50 mm

Part number	Boundary dimensions					Basic load ratings				Allowable axial load		Factor f_0	Allowable speed min^{-1} grease lubrication	Load center mm a	Mass kg Single-row (approx.)	Reference dimensions		Abutment and fillet dimensions					Part number
	mm					dynamic kN	static kgf	dynamic kgf	static kN	(static) kN	kgf					d_1	D_1	d_a min	D_a max	D_b max	r_{as} max	r_{1as} max	
	d	D	B	$r_{smin}^{1)}$	$r_{1smin}^{1)}$	C_r	C_{0r}	C_r	C_{0r}														
7900CDLLB	10	22	6	0.3	0.15	3.35	1.52	340	155	1.91	194	14.1	75 700	5.2	0.010	12.9	19.7	12.5	19.7	20.8	0.3	0.15	7900CDLLB
7901CDLLB	12	24	6	0.3	0.15	3.70	1.86	380	189	2.34	239	14.7	67 300	5.4	0.012	15.2	21.7	14.5	21.7	22.8	0.3	0.15	7901CDLLB
7902CDLLB	15	28	7	0.3	0.15	5.55	2.86	570	292	3.60	370	14.5	56 300	6.4	0.017	18.5	26.0	17.5	26.0	26.8	0.3	0.15	7902CDLLB
7903CDLLB	17	30	7	0.3	0.15	5.85	3.15	595	320	4.00	405	14.8	51 500	6.7	0.019	20.2	28.0	19.5	28.0	28.8	0.3	0.15	7903CDLLB
7904CDLLB	20	37	9	0.3	0.15	8.10	4.55	825	465	5.75	590	14.9	42 500	8.4	0.039	23.9	33.9	22.5	34.5	35.8	0.3	0.15	7904CDLLB
7905CDLLB	25	42	9	0.3	0.15	9.05	5.75	925	585	7.30	745	15.5	36 100	9.0	0.046	29.1	38.9	27.5	39.5	40.8	0.3	0.15	7905CDLLB
7906CDLLB	30	47	9	0.3	0.15	9.55	6.60	975	675	8.40	860	15.9	31 400	9.7	0.053	34.6	43.9	32.5	44.5	45.8	0.3	0.15	7906CDLLB
7907CDLLB	35	55	10	0.6	0.3	13.0	9.50	1 330	970	12.1	1 230	15.9	26 900	11.1	0.081	40.2	51.2	39.5	51.2	52.5	0.6	0.3	7907CDLLB
7908CDLLB	40	62	12	0.6	0.3	19.5	13.8	1 980	1 400	17.5	1 780	15.5	23 700	12.9	0.11	45.3	58.8	44.5	58.8	59.5	0.6	0.3	7908CDLLB
7909CDLLB	45	68	12	0.6	0.3	20.6	15.6	2 100	1 590	19.8	2 020	15.8	21 400	13.6	0.13	50.8	64.3	49.5	64.3	65.5	0.6	0.3	7909CDLLB
7910CDLLB	50	72	12	0.6	0.3	17.6	14.7	1 800	1 490	18.6	1 900	16.4	20 000	14.2	0.14	55.2	67.5	54.5	67.5	69.5	0.6	0.3	7910CDLLB

1) Minimum allowable value for corner radius dimension r or r_1 .

Angular Contact Ball Bearings for Radial Loads

Dimension Tables



Dynamic equivalent radial load
 $P_r = X F_r + Y F_a$

$i f_0 F_a$	e	Single row / Tandem				Back-to-back / Face-to-face			
		$F_a/F_r \leq e$		$F_a/F_r > e$		$F_a/F_r \leq e$		$F_a/F_r > e$	
		X	Y	X	Y	X	Y	X	Y
0.178	0.38					1.47		1.65	2.39
0.357	0.4					1.4		1.57	2.28
0.714	0.43					1.3		1.46	2.11
1.07	0.46					1.23		1.38	2
1.43	0.47					1.19		1.34	1.93
2.14	0.5	1	0	0.44		1.12	1	1.26	1.82
3.57	0.55					1.02		1.14	1.66
5.35	0.56					1		1.12	1.63
7.14	0.56					1		1.12	1.63

Static equivalent radial load

$P_{0r} = X_0 F_r + Y_0 F_a$

Single row / Tandem		Back-to-back / Face-to-face	
X_0	Y_0	X_0	Y_0
0.5	0.46	1	0.92

When $P_{0r} < F_r$ with single-row or tandem arrangement, $P_{0r} = F_r$.

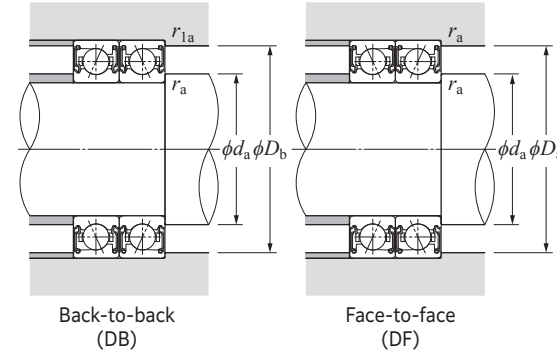

Angular Contact Ball Bearings for Radial Loads

Dimension Tables



ULTAGE Grease-lubricated sealed standard angular contact ball bearings (steel ball spec.)
79 LLB type

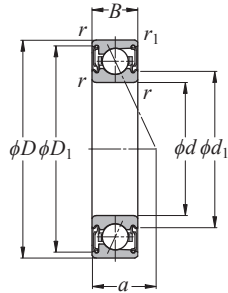

Contact angle 25° d 10–50 mm

Part number	Boundary dimensions						Basic load ratings				Allowable axial load		Allowable speed min ⁻¹ grease lubrication	Load center mm a	Mass kg Single-row (approx.)	Reference dimensions		Abutment and fillet dimensions					Part number
	mm						dynamic kN	static kN	dynamic kgf	static kgf	(static)	d_1				D_1	d_a min	D_a max	D_b max	r_{as} max	r_{1as} max		
	d	D	B	$r_{smin}^{1)}$	$r_{1smin}^{1)}$	C_r	C_{Or}	C_r	C_{Or}														
7900ADLLB	10	22	6	0.3	0.15	3.20	1.45	325	148	2.20	225	65 600	6.8	0.010	12.9	19.7	12.5	19.7	20.8	0.3	0.15	7900ADLLB	
7901ADLLB	12	24	6	0.3	0.15	3.55	1.77	360	181	2.61	267	58 300	7.2	0.012	15.2	21.7	14.5	21.7	22.8	0.3	0.15	7901ADLLB	
7902ADLLB	15	28	7	0.3	0.15	5.30	2.74	540	279	4.40	450	48 800	8.6	0.017	18.5	26.0	17.5	26.0	26.8	0.3	0.15	7902ADLLB	
7903ADLLB	17	30	7	0.3	0.15	5.55	3.00	565	305	4.75	485	44 700	9.0	0.019	20.2	28.0	19.5	28.0	28.8	0.3	0.15	7903ADLLB	
7904ADLLB	20	37	9	0.3	0.15	7.70	4.35	785	445	6.35	645	36 800	11.2	0.039	23.9	33.9	22.5	34.5	35.8	0.3	0.15	7904ADLLB	
7905ADLLB	25	42	9	0.3	0.15	8.60	5.50	875	560	7.75	790	31 300	12.4	0.046	29.1	38.9	27.5	39.5	40.8	0.3	0.15	7905ADLLB	
7906ADLLB	30	47	9	0.3	0.15	9.00	6.30	920	640	8.65	885	27 300	13.5	0.053	34.6	43.9	32.5	44.5	45.8	0.3	0.15	7906ADLLB	
7907ADLLB	35	55	10	0.6	0.3	12.3	9.00	1 260	920	13.1	1 340	23 300	15.6	0.081	40.2	51.2	39.5	51.2	52.5	0.6	0.3	7907ADLLB	
7908ADLLB	40	62	12	0.6	0.3	18.4	13.1	1 880	1 330	19.3	1 960	20 600	18.0	0.11	45.3	58.8	44.5	58.8	59.5	0.6	0.3	7908ADLLB	
7909ADLLB	45	68	12	0.6	0.3	19.5	14.8	1 980	1 510	21.5	2 190	18 600	19.3	0.13	50.8	64.3	49.5	64.3	65.5	0.6	0.3	7909ADLLB	
7910ADLLB	50	72	12	0.6	0.3	16.6	13.9	1 700	1 420	13.6	1 380	17 400	20.2	0.14	55.2	67.5	54.5	67.5	69.5	0.6	0.3	7910ADLLB	

1) Minimum allowable value for corner radius dimension r or r_1 .

Angular Contact Ball Bearings for Radial Loads

Dimension Tables



Dynamic equivalent radial load
 $P_r = X F_r + Y F_a$

e	Single row / Tandem				Back-to-back / Face-to-face			
	$F_a/F_r \leq e$		$F_a/F_r > e$		$F_a/F_r \leq e$		$F_a/F_r > e$	
	X	Y	X	Y	X	Y	X	Y
0.68	1	0	0.41	0.87	1	0.92	0.67	1.41

Static equivalent radial load
 $P_{0r} = X_0 F_r + Y_0 F_a$

Single row / Tandem		Back-to-back / Face-to-face	
X_0	Y_0	X_0	Y_0
0.5	0.38	1	0.76

When $P_{0r} < F_r$ with single-row or tandem arrangement, $P_{0r} = F_r$.

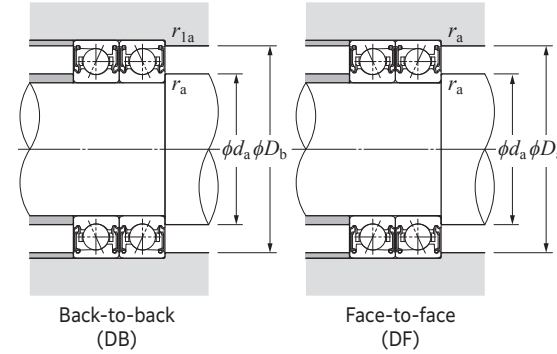

Angular Contact Ball Bearings for Radial Loads

Dimension Tables



ULTAGE Grease-lubricated sealed standard angular contact ball bearings (steel ball spec.)
70 LLB type

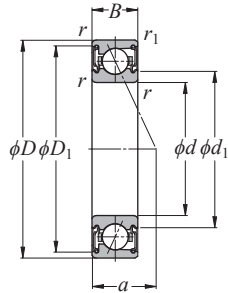

Contact angle 15° d 10–50 mm

Part number	Boundary dimensions					Basic load ratings				Allowable axial load		Factor f_0	Allowable speed min^{-1} grease lubrication	Load center mm a	Mass kg Single-row (approx.)	Reference dimensions		Abutment and fillet dimensions					Part number
	mm					dynamic kN	static kN	dynamic kgf	static kgf	kN	kgf					d_1	D_1	d_a	D_a	D_b	r_{as}	r_{1as}	
	d	D	B	$r_{smin}^{1)}$	$r_{1smin}^{1)}$	C_r	C_{0r}	C_r	C_{0r}	(static)						mm	mm	min	max	max	max	max	
7000CDLLB	10	26	8	0.3	0.15	5.90	2.49	600	254	3.10	315	12.6	67 300	6.4	0.018	14.5	23.4	12.5	23.5	24.8	0.3	0.15	7000CDLLB
7001CDLLB	12	28	8	0.3	0.15	6.40	2.90	655	296	3.65	370	13.2	60 600	6.7	0.022	16.5	25.4	14.5	25.5	26.8	0.3	0.15	7001CDLLB
7002CDLLB	15	32	9	0.3	0.15	6.90	3.40	705	345	4.25	435	14.0	51 500	7.7	0.032	19.5	28.8	17.5	29.5	30.8	0.3	0.15	7002CDLLB
7003CDLLB	17	35	10	0.3	0.15	9.10	4.50	930	460	5.70	580	13.8	46 600	8.5	0.040	21.3	32.2	19.5	32.5	33.8	0.3	0.15	7003CDLLB
7004CDLLB	20	42	12	0.6	0.3	11.6	6.00	1 180	610	7.55	770	14.0	39 100	10.2	0.070	26.0	38.0	24.5	38.0	39.5	0.6	0.3	7004CDLLB
7005CDLLB	25	47	12	0.6	0.3	13.6	8.00	1 390	815	10.1	1 030	14.7	33 600	10.9	0.083	30.4	43.1	29.5	43.1	44.5	0.6	0.3	7005CDLLB
7006CDLLB	30	55	13	1	0.6	16.8	10.3	1 710	1 050	13.0	1 320	14.9	28 500	12.2	0.11	36.4	50.4	35.5	50.4	50.5	1	0.6	7006CDLLB
7007CDLLB	35	62	14	1	0.6	21.2	13.7	2 160	1 390	17.3	1 760	15.0	25 000	13.6	0.16	41.9	57.2	40.5	57.2	57.5	1	0.6	7007CDLLB
7008CDLLB	40	68	15	1	0.6	22.8	15.9	2 320	1 620	20.1	2 050	15.4	22 400	14.8	0.19	47.9	62.7	45.5	62.7	63.5	1	0.6	7008CDLLB
7009CDLLB	45	75	16	1	0.6	30.5	21.1	3 100	2 160	26.7	2 730	15.1	20 200	16.1	0.24	53.0	70.3	50.5	70.3	70.5	1	0.6	7009CDLLB
7010CDLLB	50	80	16	1	0.6	31.5	22.9	3 250	2 330	29.0	2 960	15.4	18 600	16.8	0.26	58.0	75.3	55.5	75.3	75.5	1	0.6	7010CDLLB

Angular Contact Ball Bearings for Radial Loads

Dimension Tables



Dynamic equivalent radial load
 $P_r = X F_r + Y F_a$

$i f_0 F_a$	C_{0r}	e	Single row / Tandem				Back-to-back / Face-to-face			
			$F_a/F_r \leq e$		$F_a/F_r > e$		$F_a/F_r \leq e$		$F_a/F_r > e$	
			X	Y	X	Y	X	Y	X	Y
0.178	0.38						1.47	1.65	2.39	
0.357	0.4					1.4	1.57	2.28		
0.714	0.43					1.3	1.46	2.11		
1.07	0.46					1.23	1.38	2		
1.43	0.47					1.19	1.34	1.93		
2.14	0.5	1	0	0.44		1.12	1.26	1.82		
3.57	0.55					1.02	1.14	1.66		
5.35	0.56					1	1.12	1.63		
7.14	0.56					1	1.12	1.63		

Static equivalent radial load

$P_{0r} = X_0 F_r + Y_0 F_a$

Single row / Tandem		Back-to-back / Face-to-face	
X_0	Y_0	X_0	Y_0
0.5	0.46	1	0.92

When $P_{0r} < F_r$ with single-row or tandem arrangement, $P_{0r} = F_r$.

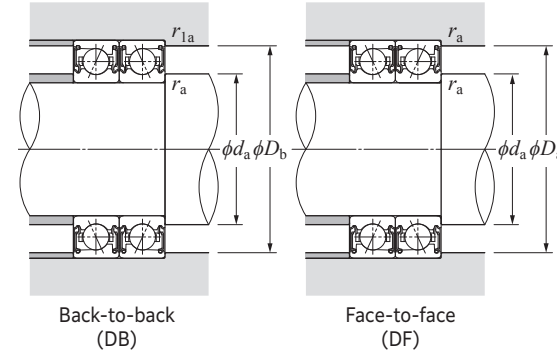

Main Spindle Bearings

Main Spindle Bearings

1) Minimum allowable value for corner radius dimension r or r_1 .

Angular Contact Ball Bearings for Radial Loads

Dimension Tables



ULTAGE Grease-lubricated sealed standard angular contact ball bearings (steel ball spec.)
70 LLB type

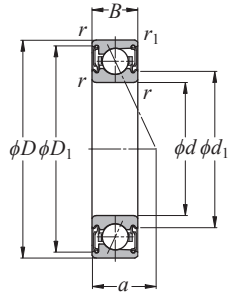

Contact angle 25° d 10–50 mm

Part number	Boundary dimensions					Basic load ratings				Allowable axial load		Allowable speed min ⁻¹	Load center mm	Mass kg	Reference dimensions		Abutment and fillet dimensions					Part number
	mm					dynamic kN	static kgf	dynamic kgf	static kgf	kN	kgf				mm		mm					
	d	D	B	$r_{smin}^{1)}$	$r_{lsmin}^{1)}$	C_r	C_{0r}	C_r	C_{0r}	(static)		grease lubrication	a	kg Single-row (approx.)	d_1	D_1	d_a min	D_a max	D_b max	r_{as} max	r_{1as} max	
7000ADLLB	10	26	8	0.3	0.15	5.70	2.41	580	245	3.85	395	58 300	8.3	0.018	14.5	23.4	12.5	23.5	24.8	0.3	0.15	7000ADLLB
7001ADLLB	12	28	8	0.3	0.15	6.20	2.79	630	285	4.50	455	52 500	8.7	0.022	16.5	25.4	14.5	25.5	26.8	0.3	0.15	7001ADLLB
7002ADLLB	15	32	9	0.3	0.15	6.60	3.25	675	330	4.95	505	44 700	10.0	0.032	19.5	28.8	17.5	29.5	30.8	0.3	0.15	7002ADLLB
7003ADLLB	17	35	10	0.3	0.15	8.75	4.35	890	445	6.95	710	40 400	11.1	0.040	21.3	32.2	19.5	32.5	33.8	0.3	0.15	7003ADLLB
7004ADLLB	20	42	12	0.6	0.3	11.1	5.75	1 130	585	8.80	900	33 900	13.3	0.070	26.0	38.0	24.5	38.0	39.5	0.6	0.3	7004ADLLB
7005ADLLB	25	47	12	0.6	0.3	13.0	7.65	1 320	780	11.3	1 150	29 200	14.5	0.083	30.4	43.1	29.5	43.1	44.5	0.6	0.3	7005ADLLB
7006ADLLB	30	55	13	1	0.6	16.0	9.80	1 630	995	14.9	1 520	24 700	16.5	0.11	36.4	50.4	35.5	50.4	50.5	1	0.6	7006ADLLB
7007ADLLB	35	62	14	1	0.6	20.1	13.0	2 050	1 330	20.4	2 080	21 600	18.4	0.16	41.9	57.2	40.5	57.2	57.5	1	0.6	7007ADLLB
7008ADLLB	40	68	15	1	0.6	21.6	15.1	2 200	1 540	23.2	2 370	19 400	20.2	0.19	47.9	62.7	45.5	62.7	63.5	1	0.6	7008ADLLB
7009ADLLB	45	75	16	1	0.6	29.1	20.1	2 970	2 050	31.0	3 150	17 500	22.1	0.24	53.0	70.3	50.5	70.3	70.5	1	0.6	7009ADLLB
7010ADLLB	50	80	16	1	0.6	30.0	21.8	3 050	2 220	33.0	3 350	16 200	23.3	0.26	58.0	75.3	55.5	75.3	75.5	1	0.6	7010ADLLB

1) Minimum allowable value for corner radius dimension r or r_1 .

Angular Contact Ball Bearings for Radial Loads

Dimension Tables



Dynamic equivalent radial load
 $P_r = X F_r + Y F_a$

e	Single row / Tandem				Back-to-back / Face-to-face			
	$F_a/F_r \leq e$		$F_a/F_r > e$		$F_a/F_r \leq e$		$F_a/F_r > e$	
	X	Y	X	Y	X	Y	X	Y
0.68	1	0	0.41	0.87	1	0.92	0.67	1.41

Static equivalent radial load
 $P_{0r} = X_0 F_r + Y_0 F_a$

e	Single row / Tandem		Back-to-back / Face-to-face	
	X_0	Y_0	X_0	Y_0
0.5	0.5	0.38	1	0.76

When $P_{0r} < F_r$ with single-row or tandem arrangement, $P_{0r} = F_r$.

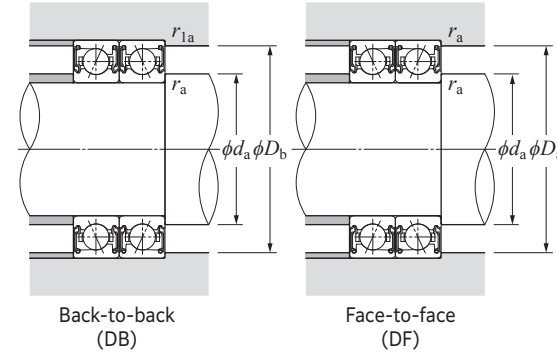

Angular Contact Ball Bearings for Radial Loads

Dimension Tables



ULTAGE Grease-lubricated sealed standard angular contact ball bearings (ceramic ball spec.)
5S-79 LLB type

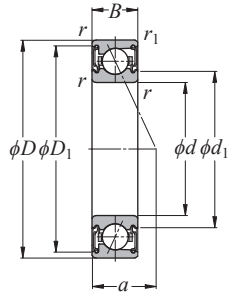

Contact angle 15° d 10–50 mm

Part number	Boundary dimensions					Basic load ratings				Allowable axial load		Factor f_0	Allowable speed min^{-1} grease lubrication	Load center mm a	Mass kg Single-row (approx.)	Reference dimensions		Abutment and fillet dimensions					Part number
	mm					dynamic kN	static kN	dynamic kgf	static kgf	kN	kgf					d_1	D_1	mm		r_{as}	r_{1as}		
	d	D	B	$r_{smin}^{1)}$	$r_{lsmin}^{1)}$	C_r	C_{0r}	C_r	C_{0r}	(static)									d_a min	D_a max	D_b max	r_{as} max	
5S-7900CDLLB	10	22	6	0.3	0.15	3.35	1.05	340	107	1.19	121	9.8	89 800	5.2	0.009	12.9	19.7	12.5	19.7	20.8	0.3	0.15	5S-7900CDLLB
5S-7901CDLLB	12	24	6	0.3	0.15	3.70	1.29	380	131	1.46	149	10.2	79 800	5.4	0.011	15.2	21.7	14.5	21.7	22.8	0.3	0.15	5S-7901CDLLB
5S-7902CDLLB	15	28	7	0.3	0.15	5.55	1.98	570	202	2.25	230	10.0	66 800	6.4	0.015	18.5	26.0	17.5	26.0	26.8	0.3	0.15	5S-7902CDLLB
5S-7903CDLLB	17	30	7	0.3	0.15	5.85	2.19	595	223	2.49	254	10.3	61 100	6.7	0.017	20.2	28.0	19.5	28.0	28.8	0.3	0.15	5S-7903CDLLB
5S-7904CDLLB	20	37	9	0.3	0.15	8.10	3.15	825	325	3.60	365	10.3	50 400	8.4	0.036	23.9	33.9	22.5	34.5	35.8	0.3	0.15	5S-7904CDLLB
5S-7905CDLLB	25	42	9	0.3	0.15	9.05	4.00	925	405	4.55	465	10.7	42 900	9.0	0.042	29.1	38.9	27.5	39.5	40.8	0.3	0.15	5S-7905CDLLB
5S-7906CDLLB	30	47	9	0.3	0.15	9.55	4.60	975	470	5.25	535	11.0	37 300	9.7	0.048	34.6	43.9	32.5	44.5	45.8	0.3	0.15	5S-7906CDLLB
5S-7907CDLLB	35	55	10	0.6	0.3	13.0	6.60	1 330	670	7.55	770	11.0	31 900	11.1	0.073	40.2	51.2	39.5	51.2	52.5	0.6	0.3	5S-7907CDLLB
5S-7908CDLLB	40	62	12	0.6	0.3	19.5	9.55	1 980	975	10.9	1 110	10.8	28 200	12.9	0.099	45.3	58.8	44.5	58.8	59.5	0.6	0.3	5S-7908CDLLB
5S-7909CDLLB	45	68	12	0.6	0.3	20.6	10.8	2 100	1 100	12.4	1 260	11.0	24 100	13.6	0.12	50.8	64.3	49.5	64.3	65.5	0.6	0.3	5S-7909CDLLB
5S-7910CDLLB	50	72	12	0.6	0.3	17.6	10.2	1 800	1 040	11.7	1 190	11.3	22 500	14.2	0.12	55.2	67.5	54.5	67.5	69.5	0.6	0.3	5S-7910CDLLB

1) Minimum allowable value for corner radius dimension r or r_1 .

Angular Contact Ball Bearings for Radial Loads

Dimension Tables



Dynamic equivalent radial load
 $P_r = X F_r + Y F_a$

$i f_0 F_a$	C_{0r}	e	Single row / Tandem				Back-to-back / Face-to-face				
			$F_a/F_r \leq e$		$F_a/F_r > e$		$F_a/F_r \leq e$		$F_a/F_r > e$		
			X	Y	X	Y	X	Y	X	Y	
0.178	0.38						1.47		1.65		2.39
0.357	0.4						1.4		1.57		2.28
0.714	0.43						1.3		1.46		2.11
1.07	0.46						1.23		1.38		2
1.43	0.47						1.19		1.34	0.72	1.93
2.14	0.5	1	0	0.44			1.12		1.26		1.82
3.57	0.55						1.02		1.14		1.66
5.35	0.56						1		1.12		1.63
7.14	0.56						1		1.12		1.63

Static equivalent radial load

$P_{0r} = X_0 F_r + Y_0 F_a$

Single row / Tandem		Back-to-back / Face-to-face	
X_0	Y_0	X_0	Y_0
0.5	0.46	1	0.92

When $P_{0r} < F_r$ with single-row or tandem arrangement, $P_{0r} = F_r$.

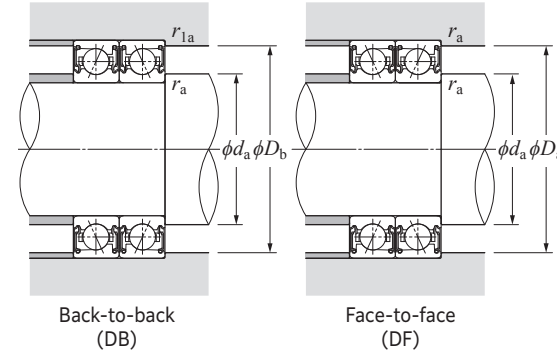

Angular Contact Ball Bearings for Radial Loads

Dimension Tables



ULTAGE Grease-lubricated sealed standard angular contact ball bearings (ceramic ball spec.)
5S-79 LLB type

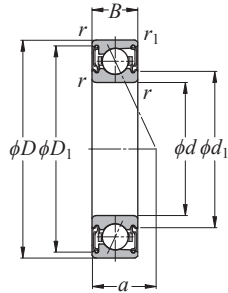

Contact angle 25° d 10–50 mm

Part number	Boundary dimensions					Basic load ratings				Allowable axial load		Allowable speed min ⁻¹ grease lubrication	Load center mm a	Mass kg Single-row (approx.)	Reference dimensions		Abutment and fillet dimensions					Part number
	mm					dynamic kN	static kN	dynamic kgf	static kgf	kN	kgf				mm		mm					
	d	D	B	$r_{smin}^{1)}$	$r_{lsmin}^{1)}$	C_r	C_{0r}	C_r	C_{0r}	(static)					d_1	D_1	d_a min	D_a max	D_b max	r_{as} max	r_{1as} max	
5S-7900ADLLB	10	22	6	0.3	0.15	3.20	1.01	325	103	1.52	155	79 700	6.8	0.009	12.9	19.7	12.5	19.7	20.8	0.3	0.15	5S-7900ADLLB
5S-7901ADLLB	12	24	6	0.3	0.15	3.55	1.23	360	125	1.86	189	70 800	7.2	0.011	15.2	21.7	14.5	21.7	22.8	0.3	0.15	5S-7901ADLLB
5S-7902ADLLB	15	28	7	0.3	0.15	5.30	1.90	540	193	2.86	292	59 300	8.6	0.015	18.5	26.0	17.5	26.0	26.8	0.3	0.15	5S-7902ADLLB
5S-7903ADLLB	17	30	7	0.3	0.15	5.55	2.09	565	213	3.15	320	54 300	9.0	0.017	20.2	28.0	19.5	28.0	28.8	0.3	0.15	5S-7903ADLLB
5S-7904ADLLB	20	37	9	0.3	0.15	7.70	3.00	785	310	4.55	465	44 700	11.2	0.036	23.9	33.9	22.5	34.5	35.8	0.3	0.15	5S-7904ADLLB
5S-7905ADLLB	25	42	9	0.3	0.15	8.60	3.80	875	385	5.75	585	38 100	12.4	0.042	29.1	38.9	27.5	39.5	40.8	0.3	0.15	5S-7905ADLLB
5S-7906ADLLB	30	47	9	0.3	0.15	9.00	4.35	920	445	6.60	670	33 100	13.5	0.048	34.6	43.9	32.5	44.5	45.8	0.3	0.15	5S-7906ADLLB
5S-7907ADLLB	35	55	10	0.6	0.3	12.3	6.25	1260	635	9.45	965	28 300	15.6	0.073	40.2	51.2	39.5	51.2	52.5	0.6	0.3	5S-7907ADLLB
5S-7908ADLLB	40	62	12	0.6	0.3	18.4	9.05	1880	925	13.7	1400	25 000	18.0	0.099	45.3	58.8	44.5	58.8	59.5	0.6	0.3	5S-7908ADLLB
5S-7909ADLLB	45	68	12	0.6	0.3	19.5	10.3	1980	1050	15.6	1590	21 400	19.3	0.12	50.8	64.3	49.5	64.3	65.5	0.6	0.3	5S-7909ADLLB
5S-7910ADLLB	50	72	12	0.6	0.3	16.6	9.60	1700	980	14.6	1490	20 000	20.2	0.12	55.2	67.5	54.5	67.5	69.5	0.6	0.3	5S-7910ADLLB

1) Minimum allowable value for corner radius dimension r or r_1 .

Angular Contact Ball Bearings for Radial Loads

Dimension Tables



Dynamic equivalent radial load
 $P_r = X F_r + Y F_a$

e	Single row / Tandem				Back-to-back / Face-to-face			
	$F_a/F_r \leq e$		$F_a/F_r > e$		$F_a/F_r \leq e$		$F_a/F_r > e$	
	X	Y	X	Y	X	Y	X	Y
0.68	1	0	0.41	0.87	1	0.92	0.67	1.41

Static equivalent radial load
 $P_{0r} = X_0 F_r + Y_0 F_a$

e	Single row / Tandem		Back-to-back / Face-to-face	
	X_0	Y_0	X_0	Y_0
	0.5	0.5	0.38	1

When $P_{0r} < F_r$ with single-row or tandem arrangement, $P_{0r} = F_r$.

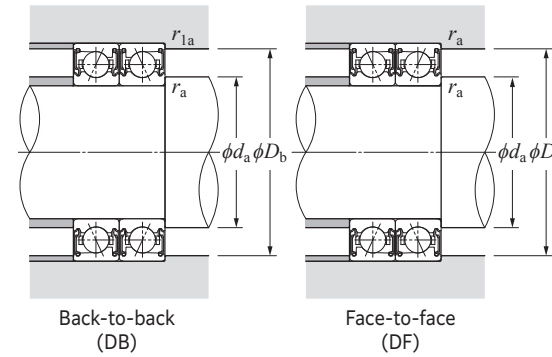

Angular Contact Ball Bearings for Radial Loads

Dimension Tables



ULTAGE Grease-lubricated sealed standard angular contact ball bearings (ceramic ball spec.)
5S-70 LLB type

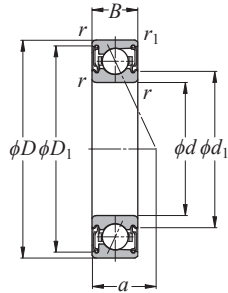

Contact angle 15° d 10–50 mm

Part number	Boundary dimensions					Basic load ratings				Allowable axial load		Factor f_0	Allowable speed min^{-1} grease lubrication	Load center mm a	Mass kg Single-row (approx.)	Reference dimensions		Abutment and fillet dimensions					Part number
	mm					dynamic kN	static kN	dynamic kgf	static kgf	kN	kgf					d_1	D_1	mm		mm			
	d	D	B	$r_{s\min}^{1)}$	$r_{1s\min}^{1)}$	C_r	C_{0r}	C_r	C_{0r}	(static)						d_a min	D_a max	D_b max	r_{as} max	r_{1as} max			
5S-7000CDLLB	10	26	8	0.3	0.15	5.90	1.73	600	176	1.93	197	8.8	80 600	6.4	0.014	14.5	23.4	12.5	23.5	24.8	0.3	0.15	5S-7000CDLLB
5S-7001CDLLB	12	28	8	0.3	0.15	6.40	2.01	655	205	2.26	231	9.2	72 600	6.7	0.020	16.5	25.4	14.5	25.5	26.8	0.3	0.15	5S-7001CDLLB
5S-7002CDLLB	15	32	9	0.3	0.15	6.90	2.35	705	239	2.66	271	9.7	61 800	7.7	0.029	19.5	28.8	17.5	29.5	30.8	0.3	0.15	5S-7002CDLLB
5S-7003CDLLB	17	35	10	0.3	0.15	9.10	3.15	930	320	3.55	360	9.6	55 800	8.5	0.035	21.3	32.2	19.5	32.5	33.8	0.3	0.15	5S-7003CDLLB
5S-7004CDLLB	20	42	12	0.6	0.3	11.6	4.15	1 180	425	4.70	480	9.7	46 800	10.2	0.064	26.0	38.0	24.5	38.0	39.5	0.6	0.3	5S-7004CDLLB
5S-7005CDLLB	25	47	12	0.6	0.3	13.6	5.55	1 390	565	6.30	640	10.2	40 300	10.9	0.075	30.4	43.1	29.5	43.1	44.5	0.6	0.3	5S-7005CDLLB
5S-7006CDLLB	30	55	13	1	0.6	16.8	7.10	1 710	725	8.10	825	10.3	34 100	12.2	0.096	36.4	50.4	35.5	50.4	50.5	1	0.6	5S-7006CDLLB
5S-7007CDLLB	35	62	14	1	0.6	21.2	9.45	2 160	965	10.8	1 100	10.4	29 900	13.6	0.14	41.9	57.2	40.5	57.2	57.5	1	0.6	5S-7007CDLLB
5S-7008CDLLB	40	68	15	1	0.6	22.8	11.0	2 320	1 120	12.6	1 280	10.6	26 900	14.8	0.17	47.9	62.7	45.5	62.7	63.5	1	0.6	5S-7008CDLLB
5S-7009CDLLB	45	75	16	1	0.6	30.5	14.6	3 100	1 490	16.7	1 700	10.4	23 300	16.1	0.21	53.0	70.3	50.5	70.3	70.5	1	0.6	5S-7009CDLLB
5S-7010CDLLB	50	80	16	1	0.6	31.5	15.9	3 250	1 620	18.1	1 850	10.6	21 500	16.8	0.23	58.0	75.3	55.5	75.3	75.5	1	0.6	5S-7010CDLLB

1) Minimum allowable value for corner radius dimension r or r_1 .

Angular Contact Ball Bearings for Radial Loads

Dimension Tables



Dynamic equivalent radial load
 $P_r = X F_r + Y F_a$

$i \cdot f_0 \cdot F_a$	C_{0r}	e	Single row / Tandem				Back-to-back / Face-to-face			
			$F_a/F_r \leq e$		$F_a/F_r > e$		$F_a/F_r \leq e$		$F_a/F_r > e$	
			X	Y	X	Y	X	Y	X	Y
0.178	0.38					1.47	1.65	1.47	1.65	2.39
0.357	0.4					1.4	1.57	1.4	1.57	2.28
0.714	0.43					1.3	1.46	1.3	1.46	2.11
1.07	0.46					1.23	1.38	1.23	1.38	2
1.43	0.47	1	0	0.44	1.19	1	1.34	0.72	1.93	
2.14	0.5					1.12	1.26	1.12	1.26	1.82
3.57	0.55					1.02	1.14	1.02	1.14	1.66
5.35	0.56					1	1.12	1	1.12	1.63
7.14	0.56					1	1.12	1	1.12	1.63

Static equivalent radial load

$P_{0r} = X_0 F_r + Y_0 F_a$

Single row / Tandem		Back-to-back / Face-to-face	
X_0	Y_0	X_0	Y_0
0.5	0.46	1	0.92

When $P_{0r} < F_r$ with single-row or tandem arrangement, $P_{0r} = F_r$.

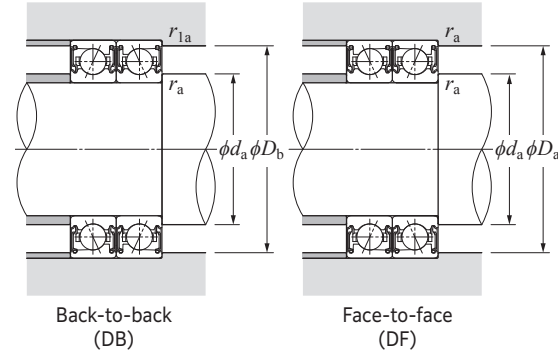

Angular Contact Ball Bearings for Radial Loads

Dimension Tables



ULTAGE Grease-lubricated sealed standard angular contact ball bearings (ceramic ball spec.)
5S-70 LLB type

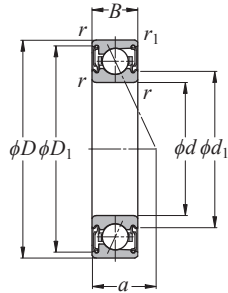

Contact angle 25° d 10–50 mm

Part number	Boundary dimensions					Basic load ratings				Allowable axial load		Allowable speed min ⁻¹ grease lubrication	Load center mm a	Mass kg Single-row (approx.)	Reference dimensions		Abutment and fillet dimensions					Part number
	mm					dynamic kN	static kN	dynamic kgf	static kgf	kN	kgf				mm		mm					
	d	D	B	$r_{smin}^{1)}$	$r_{lsmin}^{1)}$	C_r	C_{0r}	C_r	C_{0r}	(static)					d_1	D_1	d_a min	D_a max	D_b max	r_{as} max	r_{1as} max	
5S-7000ADLLB	10	26	8	0.3	0.15	5.70	1.67	580	170	2.51	256	70 600	8.3	0.014	14.5	23.4	12.5	23.5	24.8	0.3	0.15	5S-7000ADLLB
5S-7001ADLLB	12	28	8	0.3	0.15	6.20	1.93	630	197	2.92	297	63 500	8.7	0.020	16.5	25.4	14.5	25.5	26.8	0.3	0.15	5S-7001ADLLB
5S-7002ADLLB	15	32	9	0.3	0.15	6.60	2.25	675	229	3.40	345	54 000	10.0	0.029	19.5	28.8	17.5	29.5	30.8	0.3	0.15	5S-7002ADLLB
5S-7003ADLLB	17	35	10	0.3	0.15	8.75	3.00	890	305	4.55	465	48 800	11.1	0.035	21.3	32.2	19.5	32.5	33.8	0.3	0.15	5S-7003ADLLB
5S-7004ADLLB	20	42	12	0.6	0.3	11.1	4.00	1 130	405	6.00	615	41 000	13.3	0.064	26.0	38.0	24.5	38.0	39.5	0.6	0.3	5S-7004ADLLB
5S-7005ADLLB	25	47	12	0.6	0.3	13.0	5.30	1 320	540	8.00	815	35 300	14.5	0.075	30.4	43.1	29.5	43.1	44.5	0.6	0.3	5S-7005ADLLB
5S-7006ADLLB	30	55	13	1	0.6	16.0	6.80	1 630	690	10.2	1 040	29 900	16.5	0.096	36.4	50.4	35.5	50.4	50.5	1	0.6	5S-7006ADLLB
5S-7007ADLLB	35	62	14	1	0.6	20.1	9.00	2 050	920	13.6	1 390	26 200	18.4	0.14	41.9	57.2	40.5	57.2	57.5	1	0.6	5S-7007ADLLB
5S-7008ADLLB	40	68	15	1	0.6	21.6	10.5	2 200	1 070	15.8	1 620	23 500	20.2	0.17	47.9	62.7	45.5	62.7	63.5	1	0.6	5S-7008ADLLB
5S-7009ADLLB	45	75	16	1	0.6	29.1	14.0	2 970	1 420	21.1	2 150	20 300	22.1	0.21	53.0	70.3	50.5	70.3	70.5	1	0.6	5S-7009ADLLB
5S-7010ADLLB	50	80	16	1	0.6	30.0	15.1	3 050	1 540	22.8	2 330	18 800	23.3	0.23	58.0	75.3	55.5	75.3	75.5	1	0.6	5S-7010ADLLB

1) Minimum allowable value for corner radius dimension r or r_1 .

Angular Contact Ball Bearings for Radial Loads

Dimension Tables



Dynamic equivalent radial load
 $P_r = X F_r + Y F_a$

e	Single row / Tandem				Back-to-back / Face-to-face			
	$F_a/F_r \leq e$		$F_a/F_r > e$		$F_a/F_r \leq e$		$F_a/F_r > e$	
	X	Y	X	Y	X	Y	X	Y
0.68	1	0	0.41	0.87	1	0.92	0.67	1.41

Static equivalent radial load
 $P_{0r} = X_0 F_r + Y_0 F_a$

e	Single row / Tandem		Back-to-back / Face-to-face	
	X_0	Y_0	X_0	Y_0
	0.5	0.5	0.38	1

When $P_{0r} < F_r$ with single-row or tandem arrangement, $P_{0r} = F_r$.

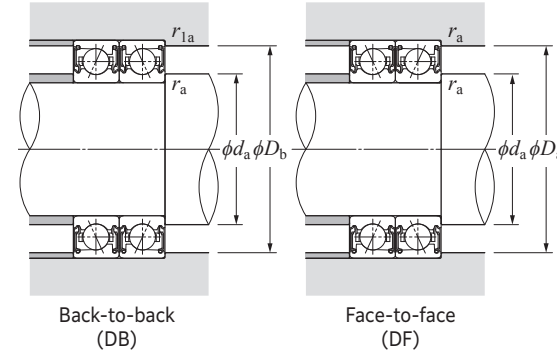

Angular Contact Ball Bearings for Radial Loads

ULTAGE Grease-lubricated sealed high speed angular contact ball bearings (steel ball spec.)
2LA-BNS9 LLB type

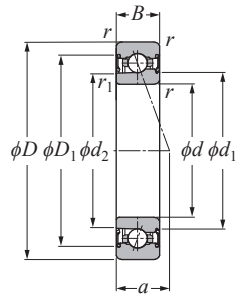

Contact angle 15° d 50–100 mm

Part number	Boundary dimensions					Basic load ratings				Allowable axial load		Factor f_0	Allowable speed min^{-1} grease lubrication	Load center mm a	Mass kg Single-row (approx.)	Reference dimensions			Abutment and fillet dimensions					Part number
	mm					dynamic kN	static kN	dynamic kgf	static kgf	kN	kgf					mm			mm					
	d	D	B	$r_s \text{ min}^{-1}$	$r_{1s} \text{ min}^{-1}$	C_r	C_{0r}	C_r	C_{0r}	(static)						d_1	d_2	D_1	$d_a \text{ min}$	$d_b \text{ min}$	$D_a \text{ max}$	$r_{as} \text{ max}$	$r_{1as} \text{ max}$	
2LA-BNS910CLLB	50	72	12	0.6	0.3	8.95	7.30	915	745	10.7	1090	11.1	21 800	14.2	0.14	56.9	56.0	65.0	54.5	52.5	67.5	0.6	0.3	2LA-BNS910CLLB
2LA-BNS911CLLB	55	80	13	1	0.6	11.4	9.20	1 170	940	13.5	1 380	11.0	19 700	15.6	0.19	62.6	61.7	72.1	60.5	59.5	74.5	1	0.6	2LA-BNS911CLLB
2LA-BNS912CLLB	60	85	13	1	0.6	11.8	9.95	1 200	1 010	14.6	1 490	11.1	18 300	16.3	0.21	67.6	66.7	77.1	65.5	64.5	79.5	1	0.6	2LA-BNS912CLLB
2LA-BNS913CLLB	65	90	13	1	0.6	12.1	10.7	1 230	1 090	15.7	1 600	11.2	17 200	16.9	0.22	72.6	71.7	82.1	70.5	69.5	84.5	1	0.6	2LA-BNS913CLLB
2LA-BNS914CLLB	70	100	16	1	0.6	15.2	13.5	1 550	1 370	19.8	2 020	11.1	15 600	19.5	0.38	79.2	78.3	90.2	75.5	74.5	94.5	1	0.6	2LA-BNS914CLLB
2LA-BNS915CLLB	75	105	16	1	0.6	15.6	14.4	1 590	1 470	21.2	2 170	11.2	14 800	20.1	0.39	84.2	83.3	95.2	80.5	79.5	99.5	1	0.6	2LA-BNS915CLLB
2LA-BNS916CLLB	80	110	16	1	0.6	16.0	15.4	1 630	1 570	22.6	2 310	11.3	14 000	20.8	0.41	89.2	88.3	100.2	85.5	84.5	104.5	1	0.6	2LA-BNS916CLLB
2LA-BNS917CLLB	85	120	18	1.1	0.6	19.3	18.3	1 960	1 860	26.9	2 740	11.2	13 000	22.8	0.59	96.0	95.0	108.6	92	89.5	113	1	0.6	2LA-BNS917CLLB
2LA-BNS918CLLB	90	125	18	1.1	0.6	19.8	19.5	2 020	1 980	28.7	2 920	11.3	12 400	23.5	0.62	100.9	100.0	113.6	97	94.5	118	1	0.6	2LA-BNS918CLLB
2LA-BNS919CLLB	95	130	18	1.1	0.6	20.3	20.6	2 070	2 110	30.5	3 100	11.3	11 800	24.2	0.65	105.9	105.0	118.6	102	99.5	123	1	0.6	2LA-BNS919CLLB
2LA-BNS920CLLB	100	140	20	1.1	0.6	28.5	28.0	2 910	2 850	41.0	4 200	11.2	11 100	26.2	0.87	111.9	110.9	127.3	107	104.5	133	1	0.6	2LA-BNS920CLLB

1) Minimum allowable value for corner radius dimension r or r_1 .

Angular Contact Ball Bearings for Radial Loads

Dynamic equivalent radial load
 $P_r = X F_r + Y F_a$

$i f_0 F_a$	e	Single row / Tandem				Back-to-back / Face-to-face				
		$F_a/F_r \leq e$		$F_a/F_r > e$		$F_a/F_r \leq e$		$F_a/F_r > e$		
		X	Y	X	Y	X	Y	X	Y	
0.178	0.35					1.57		1.76		2.56
0.357	0.36					1.53		1.71		2.48
0.714	0.38					1.46		1.64		2.38
1.07	0.4					1.42		1.59		2.31
1.43	0.41	1	0	0.44		1.38	1	1.55	0.72	2.25
2.14	0.43					1.33		1.49		2.16
3.57	0.44					1.25		1.4		2.03
5.35	0.47					1.18		1.32		1.92
7.14	0.49					1.13		1.26		1.83

Static equivalent radial load
 $P_{0r} = X_0 F_r + Y_0 F_a$

Single row / Tandem		Back-to-back / Face-to-face	
X_0	Y_0	X_0	Y_0
0.52	0.54	1.04	1.08

When $P_{0r} < F_r$ with single-row or tandem arrangement, $P_{0r} = F_r$.

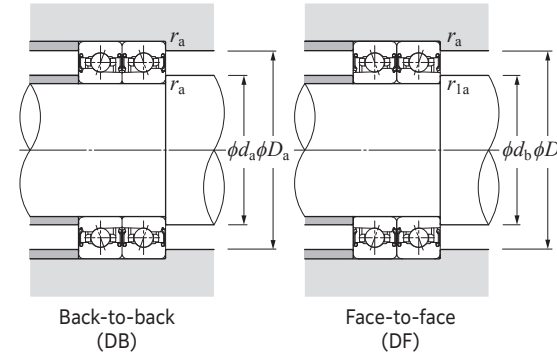

Angular Contact Ball Bearings for Radial Loads Dimension Tables

ULTAGE Grease-lubricated sealed high speed angular contact ball bearings (steel ball spec.)
2LA-BNS9 LLB type

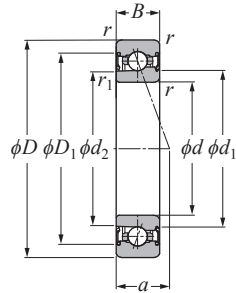

Contact angle 20° d 50–100 mm

Part number	Boundary dimensions						Basic load ratings				Allowable axial load		Allowable speed min ⁻¹ grease lubrication	Load center mm a	Mass kg Single-row (approx.)	Reference dimensions			Abutment and fillet dimensions					Part number
	mm						dynamic kN	static kN	dynamic kgf	static kgf	kN	kgf				d_1	d_2	D_1	d_a min	d_b min	D_a max	r_{as} max	r_{1as} max	
	d	D	B	$r_s \min^1$	$r_{1s} \min^1$	C_r	C_{0r}	C_r	C_{0r}	(static)														
2LA-BNS910LLB	50	72	12	0.6	0.3	8.75	7.10	890	725	11.9	1 220	23 100	17.2	0.14	56.9	56.0	65.0	54.5	52.5	67.5	0.6	0.3	2LA-BNS910LLB	
2LA-BNS911LLB	55	80	13	1	0.6	11.2	9.00	1 140	915	15.1	1 540	20 800	18.9	0.19	62.6	61.7	72.1	60.5	59.5	74.5	1	0.6	2LA-BNS911LLB	
2LA-BNS912LLB	60	85	13	1	0.6	11.5	9.70	1 170	990	16.3	1 660	19 400	19.8	0.21	67.6	66.7	77.1	65.5	64.5	79.5	1	0.6	2LA-BNS912LLB	
2LA-BNS913LLB	65	90	13	1	0.6	11.8	10.4	1 200	1 060	17.5	1 790	18 200	20.7	0.22	72.6	71.7	82.1	70.5	69.5	84.5	1	0.6	2LA-BNS913LLB	
2LA-BNS914LLB	70	100	16	1	0.6	14.8	13.1	1 510	1 340	22.1	2 250	16 600	23.6	0.38	79.2	78.3	90.2	75.5	74.5	94.5	1	0.6	2LA-BNS914LLB	
2LA-BNS915LLB	75	105	16	1	0.6	15.2	14.1	1 550	1 430	23.6	2 410	15 600	24.5	0.39	84.2	83.3	95.2	80.5	79.5	99.5	1	0.6	2LA-BNS915LLB	
2LA-BNS916LLB	80	110	16	1	0.6	15.6	15.0	1 590	1 530	25.2	2 570	14 800	25.4	0.41	89.2	88.3	100.2	85.5	84.5	104.5	1	0.6	2LA-BNS916LLB	
2LA-BNS917LLB	85	120	18	1.1	0.6	18.8	17.8	1 910	1 820	29.9	3 050	13 700	27.8	0.59	96.0	95.0	108.6	92	89.5	113	1	0.6	2LA-BNS917LLB	
2LA-BNS918LLB	90	125	18	1.1	0.6	19.3	19.0	1 960	1 930	32.0	3 250	13 100	28.7	0.62	100.9	100.0	113.6	97	94.5	118	1	0.6	2LA-BNS918LLB	
2LA-BNS919LLB	95	130	18	1.1	0.6	19.7	20.1	2 010	2 050	34.0	3 450	12 500	29.6	0.65	105.9	105.0	118.6	102	99.5	123	1	0.6	2LA-BNS919LLB	
2LA-BNS920LLB	100	140	20	1.1	0.6	27.8	27.3	2 830	2 780	46.0	4 700	11 700	32.0	0.87	111.9	110.9	127.3	107	104.5	133	1	0.6	2LA-BNS920LLB	

1) Minimum allowable value for corner radius dimension r or r_1 .

Angular Contact Ball Bearings for Radial Loads Dimension Tables

Dynamic equivalent radial load
 $P_r = X F_r + Y F_a$

e	Single row / Tandem				Back-to-back / Face-to-face			
	$F_a/F_r \leq e$	$F_a/F_r > e$	$F_a/F_r \leq e$	$F_a/F_r > e$	$F_a/F_r \leq e$	$F_a/F_r > e$	$F_a/F_r \leq e$	$F_a/F_r > e$
	X	Y	X	Y	X	Y	X	Y
0.57	1	0	0.43	1	1	1.09	0.7	1.63

Static equivalent radial load
 $P_{0r} = X_0 F_r + Y_0 F_a$

Single row / Tandem		Back-to-back / Face-to-face	
X_0	Y_0	X_0	Y_0
0.5	0.42	1	0.84

When $P_{0r} < F_r$ with single-row or tandem arrangement, $P_{0r} = F_r$.

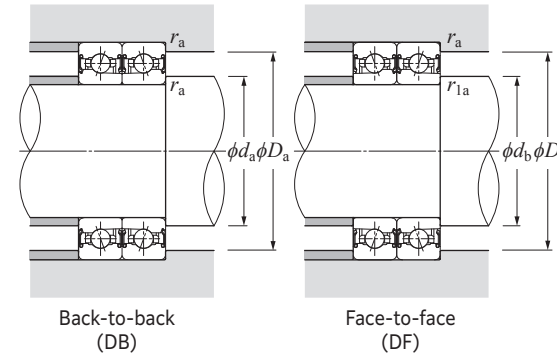

Angular Contact Ball Bearings for Radial Loads

Dimension Tables



ULTAGE Grease-lubricated sealed high speed angular contact ball bearings (steel ball spec.)
2LA-BNS9 LLB type

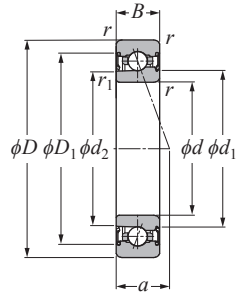

Contact angle 25° d 50–100 mm

Part number	Boundary dimensions					Basic load ratings				Allowable axial load		Allowable speed min ⁻¹ grease lubrication	Load center mm a	Mass kg Single-row (approx.)	Reference dimensions			Abutment and fillet dimensions					Part number
	mm					dynamic kN	static kgf	dynamic kgf	static	kN	kgf				mm			mm					
	d	D	B	$r_s \text{ min}^{-1}$	$r_{1s} \text{ min}^{-1}$	C_r	C_{0r}	C_r	C_{0r}	(static)					d_1	d_2	D_1	$d_a \text{ min}$	$d_b \text{ min}$	$D_a \text{ max}$	$r_{as} \text{ max}$	$r_{1as} \text{ max}$	
2LA-BNS910ADLLB	50	72	12	0.6	0.3	8.45	6.90	860	700	12.4	1 270	20 500	20.3	0.14	56.9	56.0	65.0	54.5	52.5	67.5	0.6	0.3	2LA-BNS910ADLLB
2LA-BNS911ADLLB	55	80	13	1	0.6	10.8	8.70	1 100	885	16.8	1 710	18 500	22.3	0.19	62.6	61.7	72.1	60.5	59.5	74.5	1	0.6	2LA-BNS911ADLLB
2LA-BNS912ADLLB	60	85	13	1	0.6	11.1	9.40	1 130	960	18.1	1 850	17 200	23.5	0.21	67.6	66.7	77.1	65.5	64.5	79.5	1	0.6	2LA-BNS912ADLLB
2LA-BNS913ADLLB	65	90	13	1	0.6	11.4	10.1	1 160	1 030	19.5	1 990	16 100	24.7	0.22	72.6	71.7	82.1	70.5	69.5	84.5	1	0.6	2LA-BNS913ADLLB
2LA-BNS914ADLLB	70	100	16	1	0.6	14.3	12.7	1 460	1 300	24.6	2 500	14 700	27.9	0.38	79.2	78.3	90.2	75.5	74.5	94.5	1	0.6	2LA-BNS914ADLLB
2LA-BNS915ADLLB	75	105	16	1	0.6	14.7	13.6	1 500	1 390	26.3	2 680	13 900	29.1	0.39	84.2	83.3	95.2	80.5	79.5	99.5	1	0.6	2LA-BNS915ADLLB
2LA-BNS916ADLLB	80	110	16	1	0.6	15.1	14.5	1 540	1 480	28.0	2 860	13 200	30.3	0.41	89.2	88.3	100.2	85.5	84.5	104.5	1	0.6	2LA-BNS916ADLLB
2LA-BNS917ADLLB	85	120	18	1.1	0.6	18.1	17.2	1 850	1 760	33.5	3 400	12 200	33.0	0.59	96.0	95.0	108.6	92	89.5	113	1	0.6	2LA-BNS917ADLLB
2LA-BNS918ADLLB	90	125	18	1.1	0.6	18.6	18.4	1 900	1 870	35.5	3 600	11 600	34.2	0.62	100.9	100.0	113.6	97	94.5	118	1	0.6	2LA-BNS918ADLLB
2LA-BNS919ADLLB	95	130	18	1.1	0.6	19.1	19.5	1 940	1 990	37.5	3 850	11 100	35.4	0.65	105.9	105.0	118.6	102	99.5	123	1	0.6	2LA-BNS919ADLLB
2LA-BNS920ADLLB	100	140	20	1.1	0.6	26.8	26.4	2 730	2 690	51.0	5 200	10 400	38.1	0.87	111.9	110.9	127.3	107	104.5	133	1	0.6	2LA-BNS920ADLLB

1) Minimum allowable value for corner radius dimension r or r_1 .

Angular Contact Ball Bearings for Radial Loads

Dimension Tables



Dynamic equivalent radial load
 $P_r = X F_r + Y F_a$

e	Single row / Tandem				Back-to-back / Face-to-face			
	$F_a/F_r \leq e$		$F_a/F_r > e$		$F_a/F_r \leq e$		$F_a/F_r > e$	
	X	Y	X	Y	X	Y	X	Y
0.68	1	0	0.41	0.87	1	0.92	0.67	1.41

Static equivalent radial load
 $P_{0r} = X_0 F_r + Y_0 F_a$

Single row / Tandem		Back-to-back / Face-to-face	
X_0	Y_0	X_0	Y_0
0.5	0.38	1	0.76

When $P_{0r} < F_r$ with single-row or tandem arrangement, $P_{0r} = F_r$.

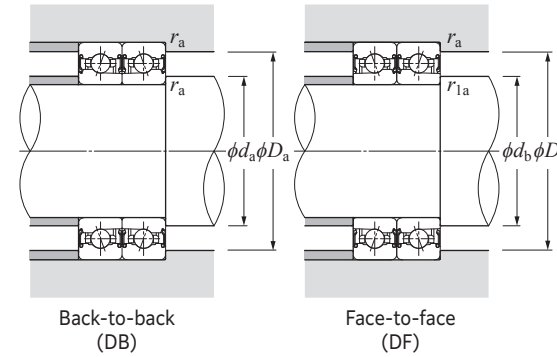

Back-to-back (DB)

Face-to-face (DF)

Angular Contact Ball Bearings for Radial Loads

ULTAGE Grease-lubricated sealed high speed angular contact ball bearings (steel ball spec.)
2LA-BNS0 LLB type

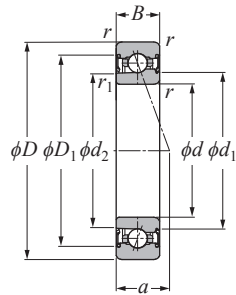

Contact angle 15° d 45–100 mm

Part number	Boundary dimensions						Basic load ratings				Allowable axial load		Factor f_0	Allowable speed min^{-1} grease lubrication	Load center mm a	Mass kg Single-row (approx.)	Reference dimensions			Abutment and fillet dimensions					Part number
	mm						dynamic kN	static kN	dynamic kgf	static kgf	(static)	mm					mm	mm	mm	mm					
	d	D	B	$r_{s \text{ min}}^{(1)}$	$r_{1s \text{ min}}^{(1)}$	C_r	C_{0r}	C_r	C_{0r}	C_r										C_{0r}	d_1	d_2	D_1	d_a min	
2LA-BNS009CLLB	45	75	16	1	0.6	13.1	9.15	1 340	930	13.4	1 370	10.7	22 200	16.1	0.26	54.1	53.3	65.0	50.5	49.5	69.5	1	0.6	2LA-BNS009CLLB	
2LA-BNS010CLLB	50	80	16	1	0.6	16.3	11.5	1 670	1 170	16.8	1 720	10.6	20 500	16.8	0.28	58.4	57.5	70.5	55.5	54.5	74.5	1	0.6	2LA-BNS010CLLB	
2LA-BNS011CLLB	55	90	18	1.1	0.6	19.1	13.6	1 950	1 380	19.9	2 030	10.6	18 300	18.8	0.41	65.2	64.1	78.7	62	59.5	83	1	0.6	2LA-BNS011CLLB	
2LA-BNS012CLLB	60	95	18	1.1	0.6	20.0	15.0	2 040	1 530	22.0	2 240	10.7	17 200	19.5	0.44	70.1	69.1	83.5	67	64.5	88	1	0.6	2LA-BNS012CLLB	
2LA-BNS013CLLB	65	100	18	1.1	0.6	20.3	15.8	2 070	1 610	23.2	2 360	10.8	16 100	20.1	0.47	75.2	74.2	88.2	72	69.5	93	1	0.6	2LA-BNS013CLLB	
2LA-BNS014CLLB	70	110	20	1.1	0.6	24.9	19.9	2 540	2 030	29.2	2 980	10.8	14 800	22.2	0.66	81.9	80.8	96.8	77	74.5	103	1	0.6	2LA-BNS014CLLB	
2LA-BNS015CLLB	75	115	20	1.1	0.6	26.5	22.4	2 700	2 290	33.0	3 350	10.9	14 000	22.8	0.69	86.8	85.8	102.2	82	79.5	108	1	0.6	2LA-BNS015CLLB	
2LA-BNS016CLLB	80	125	22	1.1	0.6	30.5	25.7	3 100	2 620	38.0	3 850	10.9	13 000	24.8	0.94	93.7	92.5	110.2	87	84.5	118	1	0.6	2LA-BNS016CLLB	
2LA-BNS017CLLB	85	130	22	1.1	0.6	30.5	26.8	3 150	2 740	39.5	4 000	10.9	12 400	25.5	0.98	98.6	97.5	115.4	92	89.5	123	1	0.6	2LA-BNS017CLLB	
2LA-BNS018CLLB	90	140	24	1.5	1	35.5	31.5	3 650	3 200	46.0	4 700	10.9	11 600	27.5	1.29	105.3	104.1	123.2	98.5	95.5	131.5	1.5	1	2LA-BNS018CLLB	
2LA-BNS019CLLB	95	145	24	1.5	1	36.0	32.5	3 700	3 350	48.0	4 900	11.0	11 100	28.2	1.34	110.4	109.1	128.1	103.5	100.5	136.5	1.5	1	2LA-BNS019CLLB	
2LA-BNS020CLLB	100	150	24	1.5	1	37.5	35.0	3 800	3 600	51.5	5 250	11.0	10 600	28.9	1.40	115.4	114.2	132.7	108.5	105.5	141.5	1.5	1	2LA-BNS020CLLB	

1) Minimum allowable value for corner radius dimension r or r_1 .

Angular Contact Ball Bearings for Radial Loads

Dynamic equivalent radial load
 $P_r = X F_r + Y F_a$

$i f_0 F_a$	e	Single row / Tandem				Back-to-back / Face-to-face			
		$F_a/F_r \leq e$		$F_a/F_r > e$		$F_a/F_r \leq e$		$F_a/F_r > e$	
		X	Y	X	Y	X	Y	X	Y
0.178	0.35				1.57		1.76		2.56
0.357	0.36				1.53		1.71		2.48
0.714	0.38				1.46		1.64		2.38
1.07	0.4				1.42		1.59		2.31
1.43	0.41	1	0	0.44	1.38	1	1.55	0.72	2.25
2.14	0.43				1.33		1.49		2.16
3.57	0.44				1.25		1.4		2.03
5.35	0.47				1.18		1.32		1.92
7.14	0.49				1.13		1.26		1.83

Static equivalent radial load
 $P_{0r} = X_0 F_r + Y_0 F_a$

Single row / Tandem		Back-to-back / Face-to-face	
X_0	Y_0	X_0	Y_0
0.52	0.54	1.04	1.08

When $P_{0r} < F_r$ with single-row or tandem arrangement, $P_{0r} = F_r$.

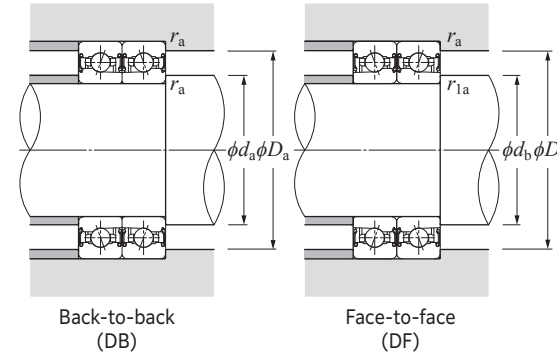

Angular Contact Ball Bearings for Radial Loads Dimension Tables



ULTAGE Grease-lubricated sealed high speed angular contact ball bearings (steel ball spec.)
2LA-BNS0 LLB type

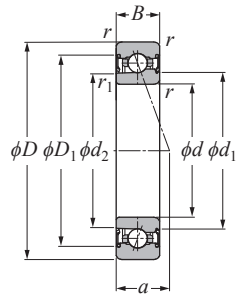

Contact angle 20° d 45-100 mm

Part number	Boundary dimensions						Basic load ratings				Allowable axial load		Allowable speed min ⁻¹ grease lubrication	Load center mm a	Mass kg Single-row (approx.)	Reference dimensions			Abutment and fillet dimensions					Part number
	mm						dynamic kN	static kN	dynamic kgf	static kgf	kN	kgf				d_1	d_2	D_1	d_a min	d_b min	D_a max	r_{as} max	r_{1as} max	
	d	D	B	r_s min ¹⁾	r_{1s} min ¹⁾	C_r	C_{0r}	C_r	C_{0r}	(static)														
2LA-BNS009LLB	45	75	16	1	0.6	12.8	8.95	1 300	910	15.0	1 530	23 500	19.0	0.26	54.1	53.3	65.0	50.5	49.5	69.5	1	0.6	2LA-BNS009LLB	
2LA-BNS010LLB	50	80	16	1	0.6	15.9	11.2	1 620	1 150	18.8	1 920	21 600	19.9	0.28	58.4	57.5	70.5	55.5	54.5	74.5	1	0.6	2LA-BNS010LLB	
2LA-BNS011LLB	55	90	18	1.1	0.6	18.7	13.3	1 900	1 350	22.2	2 260	19 400	22.3	0.41	65.2	64.2	78.7	62	59.5	83	1	0.6	2LA-BNS011LLB	
2LA-BNS012LLB	60	95	18	1.1	0.6	19.5	14.7	1 990	1 490	24.6	2 500	18 200	23.2	0.44	70.1	69.2	83.5	67	64.5	88	1	0.6	2LA-BNS012LLB	
2LA-BNS013LLB	65	100	18	1.1	0.6	19.8	15.4	2 020	1 570	25.9	2 640	17 100	24.1	0.47	75.2	74.2	88.2	72	69.5	93	1	0.6	2LA-BNS013LLB	
2LA-BNS014LLB	70	110	20	1.1	0.6	24.2	19.4	2 470	1 980	32.5	3 300	15 600	26.5	0.66	81.9	80.8	96.8	77	74.5	103	1	0.6	2LA-BNS014LLB	
2LA-BNS015LLB	75	115	20	1.1	0.6	25.8	21.9	2 630	2 230	36.5	3 750	14 800	27.4	0.69	86.8	85.8	102.2	82	79.5	108	1	0.6	2LA-BNS015LLB	
2LA-BNS016LLB	80	125	22	1.1	0.6	29.6	25.1	3 000	2 560	42.0	4 300	13 700	29.8	0.94	93.7	92.5	110.2	87	84.5	118	1	0.6	2LA-BNS016LLB	
2LA-BNS017LLB	85	130	22	1.1	0.6	30.0	26.2	3 050	2 670	44.0	4 500	13 100	30.7	0.98	98.6	97.5	115.4	92	89.5	123	1	0.6	2LA-BNS017LLB	
2LA-BNS018LLB	90	140	24	1.5	1	34.5	30.5	3 550	3 150	51.5	5 250	12 200	33.1	1.29	105.3	104.2	123.2	98.5	95.5	131.5	1.5	1	2LA-BNS018LLB	
2LA-BNS019LLB	95	145	24	1.5	1	35.0	32.0	3 600	3 250	53.5	5 450	11 700	34.0	1.34	110.4	109.2	128.1	103.5	100.5	136.5	1.5	1	2LA-BNS019LLB	
2LA-BNS020LLB	100	150	24	1.5	1	36.5	34.5	3 700	3 500	57.5	5 850	11 300	34.9	1.40	115.4	114.2	132.7	108.5	105.5	141.5	1.5	1	2LA-BNS020LLB	

1) Minimum allowable value for corner radius dimension r or r_1 .

Angular Contact Ball Bearings for Radial Loads Dimension Tables



Dynamic equivalent radial load
 $P_r = X F_r + Y F_a$

e	Single row / Tandem				Back-to-back / Face-to-face			
	$F_a/F_r \leq e$		$F_a/F_r > e$		$F_a/F_r \leq e$		$F_a/F_r > e$	
	X	Y	X	Y	X	Y	X	Y
0.57	1	0	0.43	1	1	1.09	0.7	1.63

Static equivalent radial load
 $P_{0r} = X_0 F_r + Y_0 F_a$

Single row / Tandem		Back-to-back / Face-to-face	
X_0	Y_0	X_0	Y_0
0.5	0.42	1	0.84

When $P_{0r} < F_r$ with single-row or tandem arrangement, $P_{0r} = F_r$.

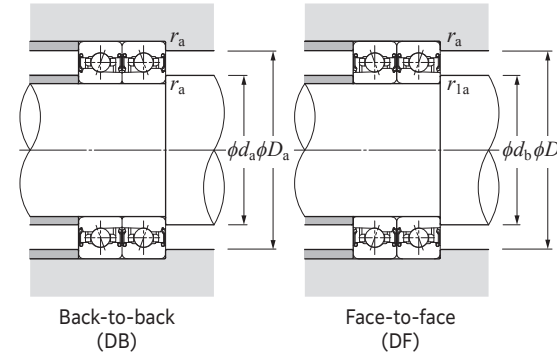

Angular Contact Ball Bearings for Radial Loads Dimension Tables

ULTAGE Grease-lubricated sealed high speed angular contact ball bearings (steel ball spec.)
2LA-BNS0 LLB type

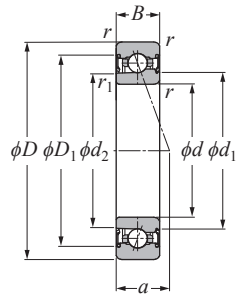

Contact angle 25° d 45–100 mm

Part number	Boundary dimensions					Basic load ratings				Allowable axial load		Allowable speed min ⁻¹ grease lubrication	Load center mm a	Mass kg Single-row (approx.)	Reference dimensions			Abutment and fillet dimensions					Part number
	mm					dynamic kN	static kN	dynamic kgf	static kgf	(static) kN	kgf				mm			mm					
	d	D	B	r_s min ¹⁾	r_{1s} min ¹⁾	C_r	C_{0r}	C_r	C_{0r}						d_1	d_2	D_1	d_a min	d_b min	D_a max	r_{as} max	r_{1as} max	
2LA-BNS009ADLLB	45	75	16	1	0.6	12.4	8.65	1 260	885	16.7	1 700	20 800	22.1	0.26	54.1	53.3	65.0	50.5	49.5	69.5	1	0.6	2LA-BNS009ADLLB
2LA-BNS010ADLLB	50	80	16	1	0.6	15.4	10.9	1 570	1 110	21.0	2 140	19 200	23.3	0.28	58.4	57.6	70.5	55.5	54.5	74.5	1	0.6	2LA-BNS010ADLLB
2LA-BNS011ADLLB	55	90	18	1.1	0.6	18.1	12.9	1 840	1 310	24.8	2 530	17 200	26.0	0.41	65.2	64.2	78.7	62	59.5	83	1	0.6	2LA-BNS011ADLLB
2LA-BNS012ADLLB	60	95	18	1.1	0.6	18.9	14.2	1 930	1 450	27.4	2 800	16 100	27.2	0.44	70.1	69.2	83.5	67	64.5	88	1	0.6	2LA-BNS012ADLLB
2LA-BNS013ADLLB	65	100	18	1.1	0.6	19.2	14.9	1 960	1 520	28.9	2 940	15 200	28.4	0.47	75.2	74.2	88.2	72	69.5	93	1	0.6	2LA-BNS013ADLLB
2LA-BNS014ADLLB	70	110	20	1.1	0.6	23.4	18.8	2 390	1 920	36.5	3 700	13 900	31.1	0.66	81.9	80.8	96.8	77	74.5	103	1	0.6	2LA-BNS014ADLLB
2LA-BNS015ADLLB	75	115	20	1.1	0.6	25.0	21.2	2 550	2 160	41.0	4 200	13 200	32.3	0.69	86.8	85.9	102.2	82	79.5	108	1	0.6	2LA-BNS015ADLLB
2LA-BNS016ADLLB	80	125	22	1.1	0.6	28.6	24.3	2 910	2 480	47.0	4 800	12 200	35.1	0.94	93.7	92.6	110.2	87	84.5	118	1	0.6	2LA-BNS016ADLLB
2LA-BNS017ADLLB	85	130	22	1.1	0.6	29.0	25.4	2 950	2 590	49.0	5 000	11 600	36.2	0.98	98.6	97.6	115.4	92	89.5	123	1	0.6	2LA-BNS017ADLLB
2LA-BNS018ADLLB	90	140	24	1.5	1	33.5	29.7	3 400	3 050	57.5	5 850	10 900	39.0	1.29	105.3	104.2	123.2	98.5	95.5	131.5	1.5	1	2LA-BNS018ADLLB
2LA-BNS019ADLLB	95	145	24	1.5	1	34.0	31.0	3 450	3 150	60.0	6 100	10 400	40.2	1.34	110.4	109.2	128.1	103.5	100.5	136.5	1.5	1	2LA-BNS019ADLLB
2LA-BNS020ADLLB	100	150	24	1.5	1	35.0	33.0	3 600	3 400	64.0	6 550	10 000	41.3	1.40	115.4	114.2	132.7	108.5	105.5	141.5	1.5	1	2LA-BNS020ADLLB

1) Minimum allowable value for corner radius dimension r or r_1 .

Angular Contact Ball Bearings for Radial Loads Dimension Tables

Dynamic equivalent radial load
 $P_r = X F_r + Y F_a$

e	Single row / Tandem				Back-to-back / Face-to-face			
	$F_a/F_r \leq e$		$F_a/F_r > e$		$F_a/F_r \leq e$		$F_a/F_r > e$	
	X	Y	X	Y	X	Y	X	Y
0.68	1	0	0.41	0.87	1	0.92	0.67	1.41

Static equivalent radial load
 $P_{0r} = X_0 F_r + Y_0 F_a$

Single row / Tandem		Back-to-back / Face-to-face	
X_0	Y_0	X_0	Y_0
0.5	0.38	1	0.76

When $P_{0r} < F_r$ with single-row or tandem arrangement, $P_{0r} = F_r$.

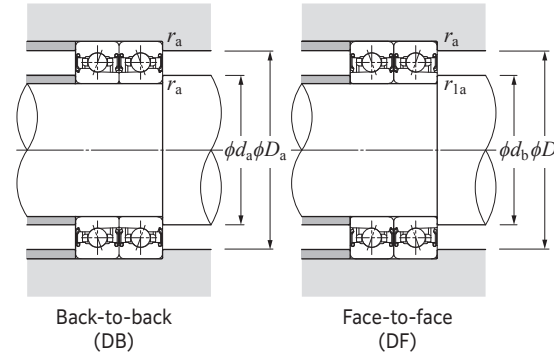

Back-to-back (DB)

Face-to-face (DF)

Angular Contact Ball Bearings for Radial Loads

Dimension Tables



ULTAGE Grease-lubricated sealed high speed angular contact ball bearings (ceramic ball spec.)
5S-2LA-BNS9 LLB type

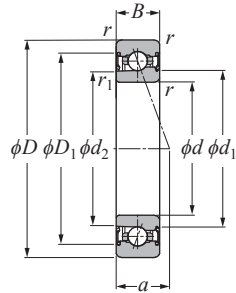

Contact angle 15° d 50–100 mm

Part number	Boundary dimensions					Basic load ratings				Allowable axial load		Factor f_0	Allowable speed min^{-1} grease lubrication	Load center mm a	Mass kg Single-row (approx.)	Reference dimensions			Abutment and fillet dimensions					Part number
	mm					dynamic kN	static kN	dynamic kgf	static kgf	kN	kgf					mm			mm					
	d	D	B	$r_s \text{ min}^{-1}$	$r_{1s} \text{ min}^{-1}$	C_r	C_{0r}	C_r	C_{0r}	(static)					d_1	d_2	D_1	d_a min	d_b min	D_a max	r_{as} max	r_{1as} max		
5S-2LA-BNS910CLLB	50	72	12	0.6	0.3	8.95	5.05	915	515	6.80	690	7.7	25 600	14.2	0.14	56.9	56.0	65.0	54.5	52.5	67.5	0.6	0.3	5S-2LA-BNS910CLLB
5S-2LA-BNS911CLLB	55	80	13	1	0.6	11.4	6.40	1 170	650	8.55	870	7.6	23 100	15.6	0.18	62.6	61.7	72.1	60.5	59.5	74.5	1	0.6	5S-2LA-BNS911CLLB
5S-2LA-BNS912CLLB	60	85	13	1	0.6	11.8	6.90	1 200	705	9.25	945	7.7	21 500	16.3	0.20	67.6	66.7	77.1	65.5	64.5	79.5	1	0.6	5S-2LA-BNS912CLLB
5S-2LA-BNS913CLLB	65	90	13	1	0.6	12.1	7.40	1 230	755	9.95	1 010	7.8	20 100	16.9	0.21	72.6	71.7	82.1	70.5	69.5	84.5	1	0.6	5S-2LA-BNS913CLLB
5S-2LA-BNS914CLLB	70	100	16	1	0.6	15.2	9.35	1 550	950	12.5	1 280	7.7	18 300	19.5	0.36	79.2	78.3	90.2	75.5	74.5	94.5	1	0.6	5S-2LA-BNS914CLLB
5S-2LA-BNS915CLLB	75	105	16	1	0.6	15.6	10.0	1 590	1 020	13.4	1 370	7.8	17 300	20.1	0.37	84.2	83.3	95.2	80.5	79.5	99.5	1	0.6	5S-2LA-BNS915CLLB
5S-2LA-BNS916CLLB	80	110	16	1	0.6	16.0	10.6	1 630	1 090	14.3	1 460	7.8	16 400	20.8	0.39	89.2	88.3	100.2	85.5	84.5	104.5	1	0.6	5S-2LA-BNS916CLLB
5S-2LA-BNS917CLLB	85	120	18	1.1	0.6	19.3	12.7	1 960	1 290	17.0	1 730	7.8	15 200	22.8	0.57	96.0	95.0	108.6	92	89.5	113	1	0.6	5S-2LA-BNS917CLLB
5S-2LA-BNS918CLLB	90	125	18	1.1	0.6	19.8	13.5	2 020	1 370	18.1	1 850	7.8	14 500	23.5	0.59	100.9	100.0	113.6	97	94.5	118	1	0.6	5S-2LA-BNS918CLLB
5S-2LA-BNS919CLLB	95	130	18	1.1	0.6	20.3	14.3	2 070	1 460	19.2	1 960	7.8	13 900	24.2	0.62	105.9	105.0	118.6	102	99.5	123	1	0.6	5S-2LA-BNS919CLLB
5S-2LA-BNS920CLLB	100	140	20	1.1	0.6	28.5	19.4	2 910	1 980	26.0	2 650	7.7	13 000	26.2	0.82	111.9	110.9	127.3	107	104.5	133	1	0.6	5S-2LA-BNS920CLLB

1) Minimum allowable value for corner radius dimension r or r_1 .

Angular Contact Ball Bearings for Radial Loads

Dimension Tables



Dynamic equivalent radial load
 $P_r = X F_r + Y F_a$

$i f_0 F_a$	e	Single row / Tandem				Back-to-back / Face-to-face			
		$F_a/F_r \leq e$		$F_a/F_r > e$		$F_a/F_r \leq e$		$F_a/F_r > e$	
		X	Y	X	Y	X	Y	X	Y
0.178	0.35					1.57	1.76	2.56	
0.357	0.36					1.53	1.71	2.48	
0.714	0.38					1.46	1.64	2.38	
1.07	0.4					1.42	1.59	2.31	
1.43	0.41	1	0	0.44		1.38	1.55	0.72	2.25
2.14	0.43					1.33	1.49	2.16	
3.57	0.44					1.25	1.4	2.03	
5.35	0.47					1.18	1.32	1.92	
7.14	0.49					1.13	1.26	1.83	

Static equivalent radial load

$P_{0r} = X_0 F_r + Y_0 F_a$

Single row / Tandem		Back-to-back / Face-to-face	
X_0	Y_0	X_0	Y_0
0.52	0.54	1.04	1.08

When $P_{0r} < F_r$ with single-row or tandem arrangement, $P_{0r} = F_r$.

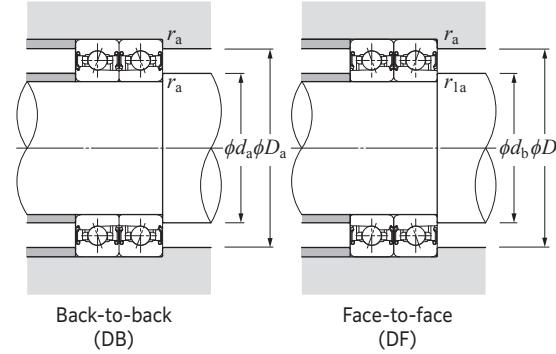

Main Spindle Bearings

Angular Contact Ball Bearings for Radial Loads

Dimension Tables



ULTAGE Grease-lubricated sealed high speed angular contact ball bearings (ceramic ball spec.)
5S-2LA-BNS9 LLB type

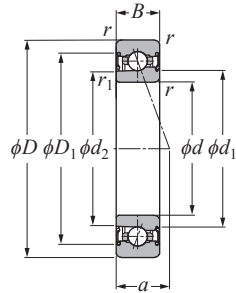

Contact angle 20° d 50–100 mm

Part number	Boundary dimensions					Basic load ratings				Allowable axial load		Allowable speed min ⁻¹ grease lubrication	Load center mm <i>a</i>	Mass kg Single-row (approx.)	Reference dimensions			Abutment and fillet dimensions					Part number
	mm					dynamic	static	dynamic	static	kN	kgf				mm			mm					
	<i>d</i>	<i>D</i>	<i>B</i>	$r_s \text{ min}^{1)}$	$r_{1s} \text{ min}^{1)}$	C_r	C_{Or}	C_r	C_{Or}	(static)	(static)				d_1	d_2	D_1	$d_a \text{ min}$	$d_b \text{ min}$	$D_a \text{ max}$	$r_{as} \text{ max}$	$r_{1as} \text{ max}$	
5S-2LA-BNS910LLB	50	72	12	0.6	0.3	8.75	4.95	890	505	7.75	790	28 200	17.2	0.14	56.9	56.0	65.0	54.5	52.5	67.5	0.6	0.3	5S-2LA-BNS910LLB
5S-2LA-BNS911LLB	55	80	13	1	0.6	11.2	6.25	1 140	635	9.75	995	25 500	18.9	0.18	62.6	61.7	72.1	60.5	59.5	74.5	1	0.6	5S-2LA-BNS911LLB
5S-2LA-BNS912LLB	60	85	13	1	0.6	11.5	6.70	1 170	685	10.5	1 080	23 700	19.8	0.20	67.6	66.7	77.1	65.5	64.5	79.5	1	0.6	5S-2LA-BNS912LLB
5S-2LA-BNS913LLB	65	90	13	1	0.6	11.8	7.20	1 200	735	11.3	1 160	22 200	20.7	0.21	72.6	71.7	82.1	70.5	69.5	84.5	1	0.6	5S-2LA-BNS913LLB
5S-2LA-BNS914LLB	70	100	16	1	0.6	14.8	9.10	1 510	930	14.3	1 460	20 200	23.6	0.36	79.2	78.3	90.2	75.5	74.5	94.5	1	0.6	5S-2LA-BNS914LLB
5S-2LA-BNS915LLB	75	105	16	1	0.6	15.2	9.75	1 550	995	15.3	1 560	19 100	24.5	0.37	84.2	83.3	95.2	80.5	79.5	99.5	1	0.6	5S-2LA-BNS915LLB
5S-2LA-BNS916LLB	80	110	16	1	0.6	15.6	10.4	1 590	1 060	16.3	1 660	18 100	25.4	0.39	89.2	88.3	100.2	85.5	84.5	104.5	1	0.6	5S-2LA-BNS916LLB
5S-2LA-BNS917LLB	85	120	18	1.1	0.6	18.8	12.3	1 910	1 260	19.4	1 980	16 800	27.8	0.57	96.0	95.0	108.6	92	89.5	113	1	0.6	5S-2LA-BNS917LLB
5S-2LA-BNS918LLB	90	125	18	1.1	0.6	19.3	13.1	1 960	1 340	20.6	2 100	16 000	28.7	0.59	100.9	100.0	113.6	97	94.5	118	1	0.6	5S-2LA-BNS918LLB
5S-2LA-BNS919LLB	95	130	18	1.1	0.6	19.7	14.0	2 010	1 420	21.9	2 230	15 300	29.6	0.62	105.9	105.0	118.6	102	99.5	123	1	0.6	5S-2LA-BNS919LLB
5S-2LA-BNS920LLB	100	140	20	1.1	0.6	27.8	18.9	2 830	1 930	29.7	3 050	14 300	32.0	0.82	111.9	110.9	127.3	107	104.5	133	1	0.6	5S-2LA-BNS920LLB

1) Minimum allowable value for corner radius dimension *r* or *r*₁.

Angular Contact Ball Bearings for Radial Loads

Dimension Tables



Dynamic equivalent radial load
 $P_r = X F_r + Y F_a$

<i>e</i>	Single row / Tandem				Back-to-back / Face-to-face			
	$F_a/F_r \leq e$		$F_a/F_r > e$		$F_a/F_r \leq e$		$F_a/F_r > e$	
	<i>X</i>	<i>Y</i>	<i>X</i>	<i>Y</i>	<i>X</i>	<i>Y</i>	<i>X</i>	<i>Y</i>
0.57	1	0	0.43	1	1	1.09	0.7	1.63

Static equivalent radial load
 $P_{0r} = X_0 F_r + Y_0 F_a$

Single row / Tandem		Back-to-back / Face-to-face	
<i>X</i> ₀	<i>Y</i> ₀	<i>X</i> ₀	<i>Y</i> ₀
0.5	0.42	1	0.84

When $P_{0r} < F_r$ with single-row or tandem arrangement, $P_{0r} = F_r$.

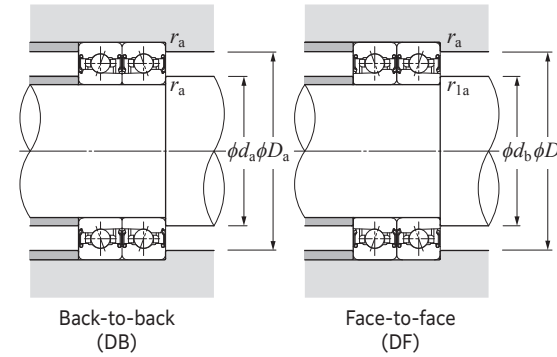

Angular Contact Ball Bearings for Radial Loads

Dimension Tables



ULTAGE Grease-lubricated sealed high speed angular contact ball bearings (ceramic ball spec.)
5S-2LA-BNS9 LLB type

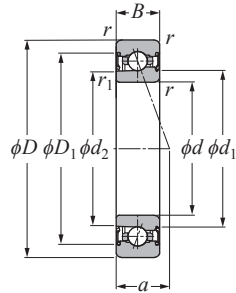

Contact angle 25° d 50–100 mm

Part number	Boundary dimensions					Basic load ratings				Allowable axial load		Allowable speed min ⁻¹ grease lubrication	Load center mm <i>a</i>	Mass kg Single-row (approx.)	Reference dimensions			Abutment and fillet dimensions					Part number
	mm					dyn	stat	dyn	stat	kN	kgf				mm			mm					
	<i>d</i>	<i>D</i>	<i>B</i>	<i>r_s</i> min ⁻¹	<i>r_{1s}</i> min ⁻¹	<i>C_r</i>	<i>C_{0r}</i>	<i>C_r</i>	<i>C_{0r}</i>	(static)	<i>d₁</i>				<i>d₂</i>	<i>D₁</i>	<i>d_a</i> min	<i>d_b</i> min	<i>D_a</i> max	<i>r_{as}</i> max	<i>r_{1as}</i> max		
5S-2LA-BNS910ADLLB	50	72	12	0.6	0.3	8.45	4.75	860	485	8.80	895	25 600	20.3	0.14	56.9	56.0	65.0	54.5	52.5	67.5	0.6	0.3	5S-2LA-BNS910ADLLB
5S-2LA-BNS911ADLLB	55	80	13	1	0.6	10.8	6.05	1 100	615	11.1	1 130	23 200	22.3	0.18	62.6	61.7	72.1	60.5	59.5	74.5	1	0.6	5S-2LA-BNS911ADLLB
5S-2LA-BNS912ADLLB	60	85	13	1	0.6	11.1	6.50	1 130	665	12.0	1 220	21 600	23.5	0.20	67.6	66.7	77.1	65.5	64.5	79.5	1	0.6	5S-2LA-BNS912ADLLB
5S-2LA-BNS913ADLLB	65	90	13	1	0.6	11.4	7.00	1 160	715	12.9	1 310	20 200	24.7	0.21	72.6	71.7	82.1	70.5	69.5	84.5	1	0.6	5S-2LA-BNS913ADLLB
5S-2LA-BNS914ADLLB	70	100	16	1	0.6	14.3	8.80	1 460	900	16.2	1 650	18 400	27.9	0.36	79.2	78.3	90.2	75.5	74.5	94.5	1	0.6	5S-2LA-BNS914ADLLB
5S-2LA-BNS915ADLLB	75	105	16	1	0.6	14.7	9.45	1 500	960	17.3	1 770	17 400	29.1	0.37	84.2	83.3	95.2	80.5	79.5	99.5	1	0.6	5S-2LA-BNS915ADLLB
5S-2LA-BNS916ADLLB	80	110	16	1	0.6	15.1	10.0	1 540	1 020	18.5	1 890	16 500	30.3	0.39	89.2	88.3	100.2	85.5	84.5	104.5	1	0.6	5S-2LA-BNS916ADLLB
5S-2LA-BNS917ADLLB	85	120	18	1.1	0.6	18.1	11.9	1 850	1 220	22.0	2 240	15 300	33.0	0.57	96.0	95.0	108.6	92	89.5	113	1	0.6	5S-2LA-BNS917ADLLB
5S-2LA-BNS918ADLLB	90	125	18	1.1	0.6	18.6	12.7	1 900	1 300	23.4	2 390	14 500	34.2	0.59	100.9	100.0	113.6	97	94.5	118	1	0.6	5S-2LA-BNS918ADLLB
5S-2LA-BNS919ADLLB	95	130	18	1.1	0.6	19.1	13.5	1 940	1 380	24.8	2 530	13 900	35.4	0.62	105.9	105.0	118.6	102	99.5	123	1	0.6	5S-2LA-BNS919ADLLB
5S-2LA-BNS920ADLLB	100	140	20	1.1	0.6	26.8	18.3	2 730	1 870	33.5	3 450	13 000	38.1	0.82	111.9	110.9	127.3	107	104.5	133	1	0.6	5S-2LA-BNS920ADLLB

Angular Contact Ball Bearings for Radial Loads

Dimension Tables



Dynamic equivalent radial load
 $P_r = X F_r + Y F_a$

<i>e</i>	Single row / Tandem				Back-to-back / Face-to-face			
	$F_a/F_r \leq e$		$F_a/F_r > e$		$F_a/F_r \leq e$		$F_a/F_r > e$	
	<i>X</i>	<i>Y</i>	<i>X</i>	<i>Y</i>	<i>X</i>	<i>Y</i>	<i>X</i>	<i>Y</i>
0.68	1	0	0.41	0.87	1	0.92	0.67	1.41

Static equivalent radial load
 $P_{0r} = X_0 F_r + Y_0 F_a$

Single row / Tandem		Back-to-back / Face-to-face	
<i>X₀</i>	<i>Y₀</i>	<i>X₀</i>	<i>Y₀</i>
0.5	0.38	1	0.76

When $P_{0r} < F_r$ with single-row or tandem arrangement, $P_{0r} = F_r$.

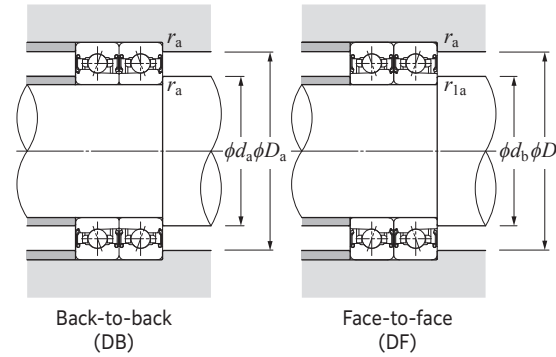

1) Minimum allowable value for corner radius dimension *r* or *r₁*.

Main Spindle Bearings

Main Spindle Bearings

Angular Contact Ball Bearings for Radial Loads

Dimension Tables



ULTAGE Grease-lubricated sealed high speed angular contact ball bearings (ceramic ball spec.)
5S-2LA-BNS0 LLB type

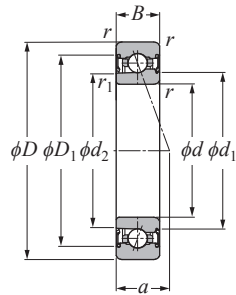

Contact angle 15° d 45–100 mm

Part number	Boundary dimensions						Basic load ratings				Allowable axial load		Factor	Allowable speed min ⁻¹	Load center mm	Mass kg	Reference dimensions			Abutment and fillet dimensions					Part number
	mm						dynamic kN	static kN	dynamic kgf	static kgf	kN	kgf					grease lubrication	mm	mm	mm	mm	mm	mm	mm	
	d	D	B	r_s min ¹⁾	r_{is} min ¹⁾	C_r	C_{0r}	C_r	C_{0r}	(static)		f_0		a	d_1	d_2	D_1	d_a min	d_b min	D_a max	r_{as} max	r_{1as} max			
5S-2LA-BNS009CLLB	45	75	16	1	0.6	13.1	6.35	1 340	645	8.45	860	7.4	26 000	16.1	0.25	54.1	53.3	65.0	50.5	49.5	69.5	1	0.6	5S-2LA-BNS009CLLB	
5S-2LA-BNS010CLLB	50	80	16	1	0.6	16.3	7.95	1 670	815	10.6	1 080	7.4	24 000	16.8	0.26	58.4	57.5	70.5	55.5	54.5	74.5	1	0.6	5S-2LA-BNS010CLLB	
5S-2LA-BNS011CLLB	55	90	18	1.1	0.6	19.1	9.40	1 950	960	12.5	1 280	7.4	21 500	18.8	0.38	65.2	64.1	78.7	62	59.5	83	1	0.6	5S-2LA-BNS011CLLB	
5S-2LA-BNS012CLLB	60	95	18	1.1	0.6	20.0	10.4	2 040	1 060	13.9	1 420	7.4	20 100	19.5	0.41	70.1	69.1	83.5	67	64.5	88	1	0.6	5S-2LA-BNS012CLLB	
5S-2LA-BNS013CLLB	65	100	18	1.1	0.6	20.3	10.9	2 070	1 120	14.6	1 490	7.5	18 900	20.1	0.44	75.2	74.2	88.2	72	69.5	93	1	0.6	5S-2LA-BNS013CLLB	
5S-2LA-BNS014CLLB	70	110	20	1.1	0.6	24.9	13.8	2 540	1 410	18.4	1 880	7.5	17 300	22.2	0.62	81.9	80.8	96.8	77	74.5	103	1	0.6	5S-2LA-BNS014CLLB	
5S-2LA-BNS015CLLB	75	115	20	1.1	0.6	26.5	15.5	2 700	1 590	20.8	2 120	7.5	16 400	22.8	0.65	86.8	85.8	102.2	82	79.5	108	1	0.6	5S-2LA-BNS015CLLB	
5S-2LA-BNS016CLLB	80	125	22	1.1	0.6	30.5	17.8	3 100	1 820	23.8	2 430	7.5	15 200	24.8	0.88	93.7	92.5	110.2	87	84.5	118	1	0.6	5S-2LA-BNS016CLLB	
5S-2LA-BNS017CLLB	85	130	22	1.1	0.6	30.5	18.6	3 150	1 900	24.9	2 540	7.6	14 500	25.5	0.93	98.6	97.5	115.4	92	89.5	123	1	0.6	5S-2LA-BNS017CLLB	
5S-2LA-BNS018CLLB	90	140	24	1.5	1	35.5	21.8	3 650	2 220	29.2	2 970	7.6	13 600	27.5	1.22	105.3	104.1	123.2	98.5	95.5	131.5	1.5	1	5S-2LA-BNS018CLLB	
5S-2LA-BNS019CLLB	95	145	24	1.5	1	36.0	22.7	3 700	2 310	30.5	3 100	7.6	13 000	28.2	1.27	110.4	109.1	128.1	103.5	100.5	136.5	1.5	1	5S-2LA-BNS019CLLB	
5S-2LA-BNS020CLLB	100	150	24	1.5	1	37.5	24.4	3 800	2 480	32.5	3 350	7.6	12 500	28.9	1.32	115.4	114.2	132.7	108.5	105.5	141.5	1.5	1	5S-2LA-BNS020CLLB	

1) Minimum allowable value for corner radius dimension r or r_1 .

Angular Contact Ball Bearings for Radial Loads

Dimension Tables



Dynamic equivalent radial load
 $P_r = X F_r + Y F_a$

$i f_0 F_a$	e	Single row / Tandem				Back-to-back / Face-to-face			
		$F_a/F_r \leq e$		$F_a/F_r > e$		$F_a/F_r \leq e$		$F_a/F_r > e$	
		X	Y	X	Y	X	Y	X	Y
0.178	0.35				1.57		1.76		2.56
0.357	0.36				1.53		1.71		2.48
0.714	0.38				1.46		1.64		2.38
1.07	0.4				1.42		1.59		2.31
1.43	0.41	1	0	0.44	1.38	1	1.55	0.72	2.25
2.14	0.43				1.33		1.49		2.16
3.57	0.44				1.25		1.4		2.03
5.35	0.47				1.18		1.32		1.92
7.14	0.49				1.13		1.26		1.83

Static equivalent radial load

$P_{0r} = X_0 F_r + Y_0 F_a$

Single row / Tandem		Back-to-back / Face-to-face	
X_0	Y_0	X_0	Y_0
0.52	0.54	1.04	1.08

When $P_{0r} < F_r$ with single-row or tandem arrangement, $P_{0r} = F_r$.

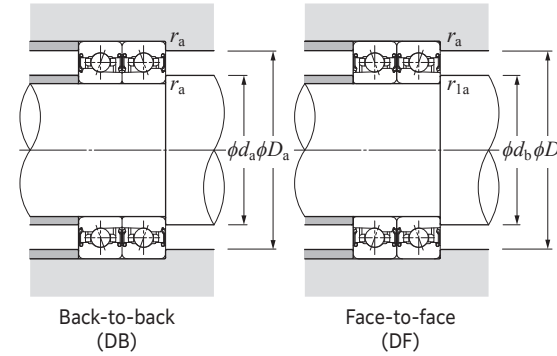

Angular Contact Ball Bearings for Radial Loads

Dimension Tables



ULTAGE Grease-lubricated sealed high speed angular contact ball bearings (ceramic ball spec.)
5S-2LA-BNS0 LLB type

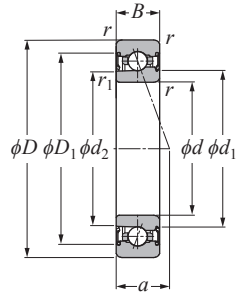

Contact angle 20° d 45–100 mm

Part number	Boundary dimensions					Basic load ratings				Allowable axial load		Allowable speed min ⁻¹ grease lubrication	Load center mm <i>a</i>	Mass kg Single-row (approx.)	Reference dimensions			Abutment and fillet dimensions					Part number
	mm					dynamic kN	static kN	dynamic kgf	static kgf	(static) kN	kgf				mm			mm					
	<i>d</i>	<i>D</i>	<i>B</i>	$r_s \min^{1)}$	$r_{1s} \min^{1)}$	C_r	C_{0r}	C_r	C_{0r}						d_1	d_2	D_1	$d_a \min$	$d_b \min$	$D_a \max$	$r_{as} \max$	$r_{1as} \max$	
5S-2LA-BNS009LLB	45	75	16	1	0.6	12.8	6.20	1 300	630	9.70	985	28 700	19.0	0.25	54.1	53.3	65.0	50.5	49.5	69.5	1	0.6	5S-2LA-BNS009LLB
5S-2LA-BNS010LLB	50	80	16	1	0.6	15.9	7.80	1 620	795	12.2	1 240	26 500	19.9	0.26	58.4	57.5	70.5	55.5	54.5	74.5	1	0.6	5S-2LA-BNS010LLB
5S-2LA-BNS011LLB	55	90	18	1.1	0.6	18.7	9.20	1 900	935	14.4	1 460	23 700	22.3	0.38	65.2	64.2	78.7	62	59.5	83	1	0.6	5S-2LA-BNS011LLB
5S-2LA-BNS012LLB	60	95	18	1.1	0.6	19.5	10.2	1 990	1 040	15.9	1 620	22 200	23.2	0.41	70.1	69.2	83.5	67	64.5	88	1	0.6	5S-2LA-BNS012LLB
5S-2LA-BNS013LLB	65	100	18	1.1	0.6	19.8	10.7	2 020	1 090	16.7	1 710	20 800	24.1	0.44	75.2	74.2	88.2	72	69.5	93	1	0.6	5S-2LA-BNS013LLB
5S-2LA-BNS014LLB	70	110	20	1.1	0.6	24.2	13.5	2 470	1 370	21.1	2 150	19 100	26.5	0.62	81.9	80.8	96.8	77	74.5	103	1	0.6	5S-2LA-BNS014LLB
5S-2LA-BNS015LLB	75	115	20	1.1	0.6	25.8	15.2	2 630	1 550	23.8	2 420	18 100	27.4	0.65	86.8	85.8	102.2	82	79.5	108	1	0.6	5S-2LA-BNS015LLB
5S-2LA-BNS016LLB	80	125	22	1.1	0.6	29.6	17.4	3 000	1 770	27.2	2 780	16 800	29.8	0.88	93.7	92.5	110.2	87	84.5	118	1	0.6	5S-2LA-BNS016LLB
5S-2LA-BNS017LLB	85	130	22	1.1	0.6	30.0	18.1	3 050	1 850	28.4	2 900	16 000	30.7	0.93	98.6	97.5	115.4	92	89.5	123	1	0.6	5S-2LA-BNS017LLB
5S-2LA-BNS018LLB	90	140	24	1.5	1	34.5	21.3	3 550	2 170	33.5	3 400	15 000	33.1	1.22	105.3	104.2	123.2	98.5	95.5	131.5	1.5	1	5S-2LA-BNS018LLB
5S-2LA-BNS019LLB	95	145	24	1.5	1	35.0	22.1	3 600	2 260	34.5	3 550	14 300	34.0	1.27	110.4	109.2	128.1	103.5	100.5	136.5	1.5	1	5S-2LA-BNS019LLB
5S-2LA-BNS020LLB	100	150	24	1.5	1	36.5	23.8	3 700	2 420	37.5	3 800	13 800	34.9	1.32	115.4	114.2	132.7	108.5	105.5	141.5	1.5	1	5S-2LA-BNS020LLB

1) Minimum allowable value for corner radius dimension *r* or *r*₁.

Angular Contact Ball Bearings for Radial Loads

Dimension Tables



Dynamic equivalent radial load
 $P_r = X F_r + Y F_a$

<i>e</i>	Single row / Tandem				Back-to-back / Face-to-face			
	$F_a/F_r \leq e$		$F_a/F_r > e$		$F_a/F_r \leq e$		$F_a/F_r > e$	
	<i>X</i>	<i>Y</i>	<i>X</i>	<i>Y</i>	<i>X</i>	<i>Y</i>	<i>X</i>	<i>Y</i>
0.57	1	0	0.43	1	1	1.09	0.7	1.63

Static equivalent radial load
 $P_{0r} = X_0 F_r + Y_0 F_a$

Single row / Tandem		Back-to-back / Face-to-face	
<i>X</i> ₀	<i>Y</i> ₀	<i>X</i> ₀	<i>Y</i> ₀
0.5	0.42	1	0.84

When $P_{0r} < F_r$ with single-row or tandem arrangement, $P_{0r} = F_r$.

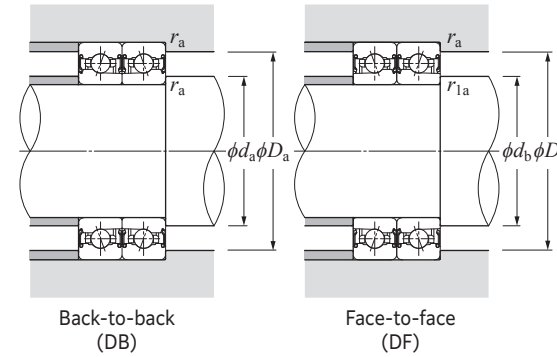

Angular Contact Ball Bearings for Radial Loads

Dimension Tables



ULTAGE Grease-lubricated sealed high speed angular contact ball bearings (ceramic ball spec.)
5S-2LA-BNS0 LLB type

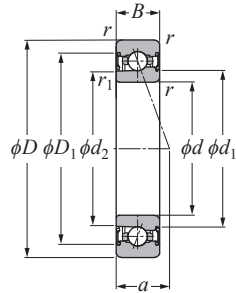

Contact angle 25° d 45–100 mm

Part number	Boundary dimensions					Basic load ratings				Allowable axial load		Allowable speed min ⁻¹ grease lubrication	Load center mm a	Mass kg Single-row (approx.)	Reference dimensions			Abutment and fillet dimensions					Part number
	mm					dynamic	static	dynamic	static	kN	kgf				mm			mm					
	d	D	B	$r_s \text{ min}^{-1}$	$r_{1s} \text{ min}^{-1}$	C_r	C_{0r}	C_r	C_{0r}	(static)					d_1	d_2	D_1	$d_a \text{ min}$	$d_b \text{ min}$	$D_a \text{ max}$	$r_{as} \text{ max}$	$r_{1as} \text{ max}$	
5S-2LA-BNS009ADLLB	45	75	16	1	0.6	12.4	6.00	1 260	610	11.0	1 120	26 100	22.1	0.25	54.1	53.3	65.0	50.5	49.5	69.5	1	0.6	5S-2LA-BNS009ADLLB
5S-2LA-BNS010ADLLB	50	80	16	1	0.6	15.4	7.55	1 570	770	13.9	1 410	24 100	23.3	0.26	58.4	57.6	70.5	55.5	54.5	74.5	1	0.6	5S-2LA-BNS010ADLLB
5S-2LA-BNS011ADLLB	55	90	18	1.1	0.6	18.1	8.90	1 840	910	16.4	1 670	21 600	26.0	0.38	65.2	64.2	78.7	62	59.5	83	1	0.6	5S-2LA-BNS011ADLLB
5S-2LA-BNS012ADLLB	60	95	18	1.1	0.6	18.9	9.85	1 930	1 000	18.1	1 840	20 200	27.2	0.41	70.1	69.2	83.5	67	64.5	88	1	0.6	5S-2LA-BNS012ADLLB
5S-2LA-BNS013ADLLB	65	100	18	1.1	0.6	19.2	10.4	1 960	1 060	19.0	1 940	19 000	28.4	0.44	75.2	74.2	88.2	72	69.5	93	1	0.6	5S-2LA-BNS013ADLLB
5S-2LA-BNS014ADLLB	70	110	20	1.1	0.6	23.4	13.0	2 390	1 330	24.0	2 440	17 400	31.1	0.62	81.9	80.8	96.8	77	74.5	103	1	0.6	5S-2LA-BNS014ADLLB
5S-2LA-BNS015ADLLB	75	115	20	1.1	0.6	25.0	14.7	2 550	1 500	27.0	2 760	16 500	32.3	0.65	86.8	85.9	102.2	82	79.5	108	1	0.6	5S-2LA-BNS015ADLLB
5S-2LA-BNS016ADLLB	80	125	22	1.1	0.6	28.6	16.9	2 910	1 720	31.0	3 150	15 300	35.1	0.88	93.7	92.6	110.2	87	84.5	118	1	0.6	5S-2LA-BNS016ADLLB
5S-2LA-BNS017ADLLB	85	130	22	1.1	0.6	29.0	17.6	2 950	1 790	32.5	3 300	14 500	36.2	0.93	98.6	97.6	115.4	92	89.5	123	1	0.6	5S-2LA-BNS017ADLLB
5S-2LA-BNS018ADLLB	90	140	24	1.5	1	33.5	20.6	3 400	2 100	38.0	3 850	13 600	39.0	1.22	105.3	104.2	123.2	98.5	95.5	131.5	1.5	1	5S-2LA-BNS018ADLLB
5S-2LA-BNS019ADLLB	95	145	24	1.5	1	34.0	21.4	3 450	2 190	39.5	4 000	13 000	40.2	1.27	110.4	109.2	128.1	103.5	100.5	136.5	1.5	1	5S-2LA-BNS019ADLLB
5S-2LA-BNS020ADLLB	100	150	24	1.5	1	35.0	23.0	3 600	2 350	42.5	4 300	12 500	41.3	1.32	115.4	114.2	132.7	108.5	105.5	141.5	1.5	1	5S-2LA-BNS020ADLLB

1) Minimum allowable value for corner radius dimension r or r_1 .

Angular Contact Ball Bearings for Radial Loads

Dimension Tables



Dynamic equivalent radial load
 $P_r = X F_r + Y F_a$

e	Single row / Tandem				Back-to-back / Face-to-face			
	$F_a/F_r \leq e$		$F_a/F_r > e$		$F_a/F_r \leq e$		$F_a/F_r > e$	
	X	Y	X	Y	X	Y	X	Y
0.68	1	0	0.41	0.87	1	0.92	0.67	1.41

Static equivalent radial load
 $P_{0r} = X_0 F_r + Y_0 F_a$

Single row / Tandem		Back-to-back / Face-to-face	
X_0	Y_0	X_0	Y_0
0.5	0.38	1	0.76

When $P_{0r} < F_r$ with single-row or tandem arrangement, $P_{0r} = F_r$.

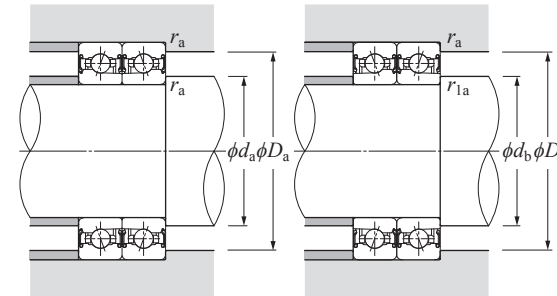

Back-to-back (DB)

Face-to-face (DF)

Angular Contact Ball Bearings for Radial Loads Dimension Tables



Angular contact ball bearings for grinding machines / motors
(steel ball spec.)
BNT9 type

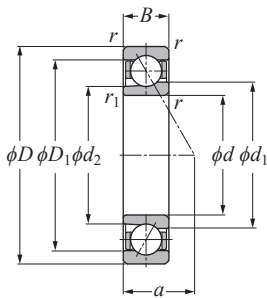

Contact angle 15° d 10–65 mm

Part number	Boundary dimensions					Basic load ratings				Allowable axial load		Factor f_0	Allowable speed		Load center mm a	Internal free space cm ³ Single-row (approx.)	Mass kg Single-row (approx.)	Reference dimensions			Abutment and fillet dimensions					Part number
	mm					dynamic kN	static kN	dynamic kgf	static kgf	(static) kN	kgf		grease lubrication	oil lubrication				d_1	d_2	D_1	mm					
	d	D	B	$r_s \min^{1)}$	$r_{1s} \min^{1)}$	C_r	C_{0r}	C_r	C_{0r}												d_a min	d_b min	D_a max	r_{as} max	r_{1as} max	
BNT900	10	22	6	0.3	0.15	2.55	0.995	260	101	1.43	146	9.3	62 200	125 600	5.2	0.3	0.010	14.0	12.7	18.0	12.2	11.2	20	0.3	0.15	BNT900
BNT901	12	24	6	0.3	0.15	2.70	1.12	275	114	1.76	180	9.6	55 300	111 700	5.4	0.4	0.011	16.0	14.7	20.0	14.2	13.2	22	0.3	0.15	BNT901
BNT902	15	28	7	0.3	0.15	4.10	1.75	415	179	2.54	259	9.5	46 300	93 500	6.4	0.6	0.016	19.0	17.4	24.0	17.2	16.2	26	0.3	0.15	BNT902
BNT903	17	30	7	0.3	0.15	4.30	1.95	440	199	2.82	288	9.7	42 300	85 500	6.7	0.8	0.017	21.0	19.4	26.0	19.2	18.2	28	0.3	0.15	BNT903
BNT904	20	37	9	0.3	0.15	6.20	2.99	630	305	4.35	440	9.7	34 900	70 500	8.4	1.4	0.037	25.5	23.5	31.4	22.5	21.5	34.5	0.3	0.15	BNT904
BNT905	25	42	9	0.3	0.15	6.65	3.55	675	360	5.15	525	10.1	29 700	60 000	9.0	1.7	0.043	30.5	28.5	36.5	27.5	26.5	39.5	0.3	0.15	BNT905
BNT906	30	47	9	0.3	0.15	7.05	4.10	715	420	6.00	610	10.4	25 800	52 200	9.7	1.9	0.049	35.5	33.5	41.5	32.5	31.5	44.5	0.3	0.15	BNT906
BNT907	35	55	10	0.6	0.3	11.1	6.30	1 140	645	9.20	940	10.1	21 000	42 400	11.1	2.8	0.073	41.2	38.5	48.8	39.5	37.5	50.5	0.6	0.3	BNT907
BNT908	40	62	12	0.6	0.3	11.8	7.30	1 210	740	10.6	1 080	10.4	18 500	37 500	12.9	4.5	0.11	47.0	44.4	55.0	44.5	42.5	57.5	0.6	0.3	BNT908
BNT909	45	68	12	0.6	0.3	14.7	9.20	1 490	935	13.4	1 370	10.4	16 700	33 800	13.6	5.2	0.13	52.1	49.1	60.9	49.5	48	63.5	0.6	0.3	BNT909
BNT910	50	72	12	0.6	0.3	15.5	10.3	1 580	1 060	15.1	1 540	10.5	15 500	31 300	14.2	6.2	0.13	56.6	53.6	65.4	54.5	52.5	67.5	0.6	0.3	BNT910
BNT911	55	80	13	1	0.6	16.2	11.6	1 650	1 180	17.0	1 730	10.7	13 800	27 600	15.6	7.8	0.18	63.2	60.1	71.8	60.5	59.5	74.5	1	0.6	BNT911
BNT912	60	85	13	1	0.6	16.9	12.8	1 730	1 300	18.7	1 910	10.8	12 800	25 700	16.3	8.3	0.20	68.1	65.1	76.9	65.5	64.5	79.5	1	0.6	BNT912
BNT913	65	90	13	1	0.6	17.1	13.4	1 750	1 370	19.7	2 010	10.9	12 000	24 000	17.0	8.9	0.21	73.1	70.1	81.9	70.5	69.5	84.5	1	0.6	BNT913

1) Minimum allowable value for corner radius dimension r or r_1 .

Angular Contact Ball Bearings for Radial Loads Dimension Tables



Dynamic equivalent radial load

$$P_r = X F_r + Y F_a$$

$i \cdot f_0 \cdot F_a$	e	Single row / Tandem				Back-to-back / Face-to-face			
		$F_a/F_r \leq e$		$F_a/F_r > e$		$F_a/F_r \leq e$		$F_a/F_r > e$	
		X	Y	X	Y	X	Y	X	Y
0.178	0.35				1.57		1.76		2.56
0.357	0.36				1.53		1.71		2.48
0.714	0.38				1.46		1.64		2.38
1.07	0.4				1.42		1.59		2.31
1.43	0.41	1	0	0.44	1.38	1	1.55	0.72	2.25
2.14	0.43				1.33		1.49		2.16
3.57	0.44				1.25		1.4		2.03
5.35	0.47				1.18		1.32		1.92
7.14	0.49				1.13		1.26		1.83

Static equivalent radial load

$$P_{0r} = X_0 F_r + Y_0 F_a$$

Single row / Tandem		Back-to-back / Face-to-face	
X_0	Y_0	X_0	Y_0
0.52	0.54	1.04	1.08

When $P_{0r} < F_r$ with single-row or tandem arrangement, $P_{0r} = F_r$.

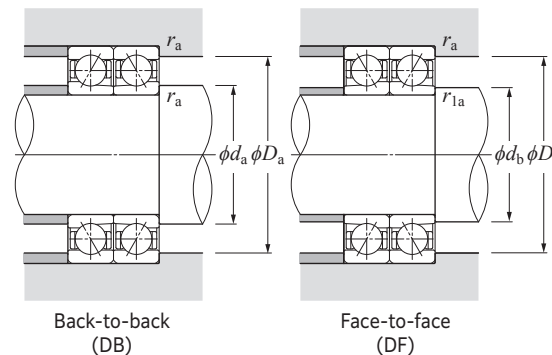

Angular Contact Ball Bearings for Radial Loads Dimension Tables



Angular contact ball bearings for grinding machines / motors
(steel ball spec.)
BNT0 type

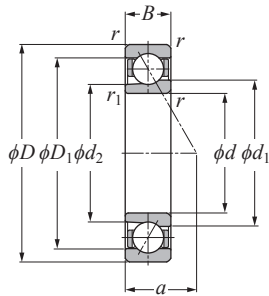

Contact angle 15° d 10–70 mm

Part number	Boundary dimensions					Basic load ratings				Allowable axial load		Factor f_0	Allowable speed		Load center mm a	Internal free space cm^3 (approx.)	Mass kg (approx.)	Reference dimensions			Abutment and fillet dimensions					Part number
	mm					dynamic kN	static kN	dynamic kgf	static kgf	(static)	grease lubrication		oil lubrication	mm				mm								
	d	D	B	$r_s \min^{-1}$	$r_{1s} \min^{-1}$	C_r	C_{0r}	C_r	C_{0r}		C_r		C_{0r}	d_1				d_2	D_1	$d_a \min$	$d_b \min$	$D_a \max$	$r_{as} \max$	$r_{1as} \max$		
BNT000	10	26	8	0.3	0.15	4.15	1.45	425	148	2.07	211	8.3	60 300	120 100	6.5	0.9	0.015	14.6	13.0	21.0	12.5	11.2	23.5	0.3	0.15	BNT000
BNT001	12	28	8	0.3	0.15	4.60	1.73	470	176	2.48	253	8.8	52 700	104 900	6.8	1.0	0.020	17.4	15.6	23.5	14.5	13.2	25.5	0.3	0.15	BNT001
BNT002	15	32	9	0.3	0.15	5.30	2.22	540	226	3.20	325	9.2	46 000	91 500	7.7	1.3	0.029	20.4	18.5	26.5	17.5	16.2	29.5	0.3	0.15	BNT002
BNT003	17	35	10	0.3	0.15	6.55	2.70	665	275	3.90	395	9.0	41 500	82 700	8.5	1.8	0.033	22.2	20.2	29.6	19.5	18.2	32.5	0.3	0.15	BNT003
BNT004	20	42	12	0.6	0.3	8.90	3.95	905	405	5.70	580	9.2	34 300	68 300	10.3	3.0	0.057	27.4	24.9	35.5	24.5	22.5	37.5	0.6	0.3	BNT004
BNT005	25	47	12	0.6	0.3	9.90	4.85	1010	495	7.05	720	9.6	30 000	59 700	10.9	3.5	0.067	31.8	29.4	40.6	29.5	27.5	42.5	0.6	0.3	BNT005
BNT006	30	55	13	1	0.6	12.8	6.75	1310	685	9.75	995	9.8	25 100	50 000	12.3	4.3	0.11	38.4	35.5	47.8	35.5	34.5	49.5	1	0.6	BNT006
BNT007	35	62	14	1	0.6	16.2	8.95	1650	910	13.0	1320	9.8	20 100	40 200	13.6	6.5	0.15	43.4	40.2	53.8	40.5	39.5	56.5	1	0.6	BNT007
BNT008	40	68	15	1	0.6	17.4	10.4	1780	1060	15.1	1540	10.0	18 100	36 100	14.8	8.0	0.18	48.8	45.7	59.4	45.5	44.5	62.5	1	0.6	BNT008
BNT009	45	75	16	1	0.6	20.7	12.6	2110	1280	18.4	1870	10.1	16 300	32 500	16.1	9.6	0.23	54.2	50.9	65.6	50.5	49.5	69.5	1	0.6	BNT009
BNT010	50	80	16	1	0.6	22.0	14.3	2240	1460	20.9	2130	10.2	15 000	30 000	16.8	11	0.26	59.6	55.9	70.2	55.5	54.5	74.5	1	0.6	BNT010
BNT011	55	90	18	1.1	0.6	28.9	18.7	2950	1910	27.3	2780	10.1	13 200	26 400	18.8	16	0.38	66.1	61.8	79.1	62	59.5	83	1	0.6	BNT011
BNT012	60	95	18	1.1	0.6	29.7	20.0	3050	2040	29.2	2980	10.3	12 300	24 700	19.5	19	0.40	71.1	66.8	84.1	67	64.5	88	1	0.6	BNT012
BNT013	65	100	18	1.1	0.6	31.5	22.4	3200	2290	32.5	3350	10.4	11 600	23 200	20.2	20	0.42	75.2	71.8	89.8	72	69.5	93	1	0.6	BNT013
BNT014	70	110	20	1.1	0.6	39.5	28.1	4050	2870	41.0	4200	10.3	10 600	21 300	22.2	27	0.56	82.3	77.7	97.9	77	74.5	103	1	0.6	BNT014

1) Minimum allowable value for corner radius dimension r or r_1 .

Angular Contact Ball Bearings for Radial Loads Dimension Tables



Dynamic equivalent radial load
 $P_r = X F_r + Y F_a$

$i \cdot f_0 \cdot F_a$	C_{0r}	e	Single row / Tandem				Back-to-back / Face-to-face			
			$F_a/F_r \leq e$		$F_a/F_r > e$		$F_a/F_r \leq e$		$F_a/F_r > e$	
			X	Y	X	Y	X	Y	X	Y
0.178	0.35					1.57		1.76		2.56
0.357	0.36					1.53		1.71		2.48
0.714	0.38					1.46		1.64		2.38
1.07	0.4					1.42		1.59		2.31
1.43	0.41	1	0	0.44		1.38	1	1.55	0.72	2.25
2.14	0.43					1.33		1.49		2.16
3.57	0.44					1.25		1.4		2.03
5.35	0.47					1.18		1.32		1.92
7.14	0.49					1.13		1.26		1.83

Static equivalent radial load
 $P_{0r} = X_0 F_r + Y_0 F_a$

Single row / Tandem		Back-to-back / Face-to-face	
X_0	Y_0	X_0	Y_0
0.52	0.54	1.04	1.08

When $P_{0r} < F_r$ with single-row or tandem arrangement, $P_{0r} = F_r$.

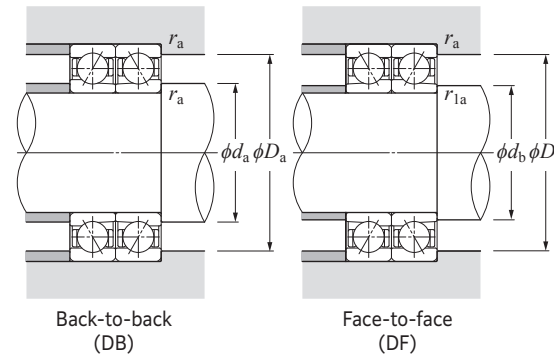

Main Spindle Bearings

Angular Contact Ball Bearings for Radial Loads

Dimension Tables



Angular contact ball bearings for grinding machines / motors (steel ball spec.) BNT2 type

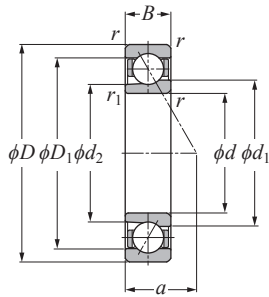

Contact angle 15° d 10–80 mm

Part number	Boundary dimensions					Basic load ratings				Allowable axial load		Factor f_0	Allowable speed		Load center a mm	Internal free space cm^3 (approx.)	Mass kg (approx.)	Reference dimensions			Abutment and fillet dimensions					Part number
	mm					dynamic kN	static kgf	dynamic kgf	static kN	(static)			grease lubrication	oil lubrication				mm			mm					
	d	D	B	$r_s \min^1$	$r_{1s} \min^1$	C_r	C_{0r}	C_r	C_{0r}									d_1	d_2	D_1	$d_a \min$	$d_b \min$	$D_a \max$	$r_{as} \max$	$r_{1as} \max$	
BNT200	10	30	9	0.6	0.3	4.60	1.71	465	175	2.46	250	8.7	53 300	106 800	7.2	1.1	0.019	17.0	15.0	23.0	14.5	12.5	25.5	0.6	0.3	BNT200
BNT201	12	32	10	0.6	0.3	6.00	2.28	610	232	3.25	330	8.5	48 400	97 000	8.0	1.5	0.025	18.4	16.2	26.0	16.5	14.5	27.5	0.6	0.3	BNT201
BNT202	15	35	11	0.6	0.3	7.60	2.97	775	300	4.25	430	8.5	42 600	85 400	8.9	2.2	0.035	20.8	18.4	29.4	19.5	17.5	30.5	0.6	0.3	BNT202
BNT203	17	40	12	0.6	0.3	9.45	3.80	965	385	5.40	555	8.5	37 000	74 100	9.9	2.9	0.054	24.2	21.4	33.6	21.5	19.5	35.5	0.6	0.3	BNT203
BNT204	20	47	14	1	0.6	12.4	5.35	1 260	545	7.70	785	8.8	30 900	61 900	11.7	4.6	0.092	29.4	26.2	39.4	25.5	24.5	41.5	1	0.6	BNT204
BNT205	25	52	15	1	0.6	14.1	6.70	1 430	685	9.70	990	9.2	27 300	54 700	12.8	6.1	0.13	33.8	30.7	44.2	30.5	29.5	46.5	1	0.6	BNT205
BNT206	30	62	16	1	0.6	19.5	9.65	1 990	985	13.9	1 420	9.2	22 900	45 900	14.3	8.3	0.20	40.6	36.6	52.6	35.5	34.5	56.5	1	0.6	BNT206
BNT207	35	72	17	1.1	0.6	25.7	13.1	2 620	1 330	18.8	1 920	9.1	18 100	36 000	15.8	10	0.29	46.8	42.0	60.6	42	39.5	65	1	0.6	BNT207
BNT208	40	80	18	1.1	0.6	31.0	16.5	3 150	1 680	23.8	2 430	9.3	16 200	32 100	17.2	13	0.38	53.0	47.7	67.0	47	44.5	73	1	0.6	BNT208
BNT209	45	85	19	1.1	0.6	34.5	18.9	3 500	1 920	27.3	2 780	9.3	14 900	29 600	18.3	16	0.44	57.3	51.9	73.0	52	49.5	78	1	0.6	BNT209
BNT210	50	90	20	1.1	0.6	36.5	20.8	3 700	2 120	30.0	3 050	9.5	13 900	27 500	19.5	20	0.46	62.2	56.8	78.0	57	54.5	83	1	0.6	BNT210
BNT211	55	100	21	1.5	1	45.0	26.2	4 550	2 670	38.0	3 850	9.5	12 300	24 400	21.0	25	0.61	69.0	62.8	86.4	63.5	60.5	91.5	1.5	1	BNT211
BNT212	60	110	22	1.5	1	54.0	32.5	5 550	3 300	47.0	4 800	9.5	11 000	21 800	22.8	32	0.78	77.0	70.2	96.4	68.5	65.5	101.5	1.5	1	BNT212
BNT213	65	120	23	1.5	1	59.0	36.0	6 050	3 650	52.0	5 300	9.5	10 300	20 400	24.1	37	1.01	82.5	75.3	102.5	73.5	70.5	111.5	1.5	1	BNT213
BNT214	70	125	24	1.5	1	64.5	39.5	6 550	4 000	57.0	5 800	9.6	9 700	19 400	25.2	47	1.08	87.0	79.5	108.0	78.5	75.5	116.5	1.5	1	BNT214
BNT215	75	130	25	1.5	1	67.0	43.0	6 850	4 400	62.5	6 350	9.7	9 200	18 300	26.6	54	1.17	93.0	85.5	114.5	83.5	80.5	121.5	1.5	1	BNT215
BNT216	80	140	26	2	1	78.5	50.5	8 000	5 150	73.5	7 500	9.7	8 600	17 200	27.9	58	1.45	98.1	90.4	122.0	90	85.5	130	2	1	BNT216

1) Minimum allowable value for corner radius dimension r or r_1 .

Angular Contact Ball Bearings for Radial Loads

Dimension Tables



Dynamic equivalent radial load $P_r = X F_r + Y F_a$

$i f_0 F_a$	C_{0r}	e	Single row / Tandem				Back-to-back / Face-to-face				
			$F_a/F_r \leq e$		$F_a/F_r > e$		$F_a/F_r \leq e$		$F_a/F_r > e$		
			X	Y	X	Y	X	Y	X	Y	
0.178	0.35					1.57	1.76			2.56	
0.357	0.36					1.53	1.71			2.48	
0.714	0.38					1.46	1.64			2.38	
1.07	0.4					1.42	1.59			2.31	
1.43	0.41	1	0	0.44		1.38	1	1.55	0.72	2.25	
2.14	0.43					1.33	1.49			2.16	
3.57	0.44					1.25	1.4			2.03	
5.35	0.47					1.18	1.32			1.92	
7.14	0.49					1.13	1.26			1.83	

Static equivalent radial load $P_{0r} = X_0 F_r + Y_0 F_a$

Single row / Tandem		Back-to-back / Face-to-face	
X_0	Y_0	X_0	Y_0
0.52	0.54	1.04	1.08

When $P_{0r} < F_r$ with single-row or tandem arrangement, $P_{0r} = F_r$.

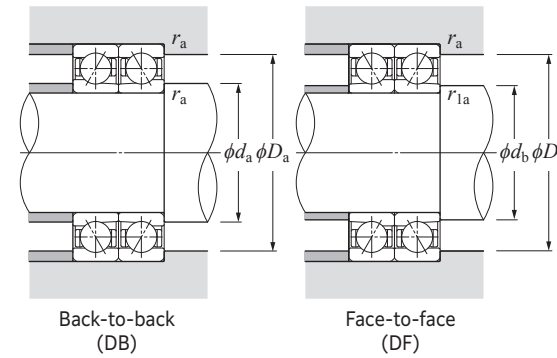

Angular Contact Ball Bearings for Radial Loads

Dimension Tables



Angular contact ball bearings for grinding machines / motors (ceramic ball spec.)
5S-BNT9 type

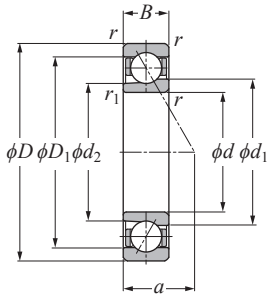

Contact angle 15° d 10–65 mm

Part number	Boundary dimensions					Basic load ratings				Allowable axial load		Factor f_0	Allowable speed		Load center a mm	Internal free space cm^3 (approx.)	Mass kg (approx.)	Reference dimensions			Abutment and fillet dimensions					Part number
	mm					dynamic kN	static kN	dynamic kgf	static kgf	(static) kN	kgf		grease lubrication min^{-1}	oil lubrication min^{-1}				d_1	d_2	D_1	mm					
	d	D	B	$r_s \min^{1)}$	$r_{1s} \min^{1)}$	C_r	C_{0r}	C_r	C_{0r}												$d_a \min$	$d_b \min$	$D_a \max$	$r_{as} \max$	$r_{1as} \max$	
5S-BNT900	10	22	6	0.3	0.15	2.55	0.69	260	70	0.905	92	6.4	72 500	145 600	5.2	0.3	0.009	14.0	12.7	18.0	12.2	11.2	20	0.3	0.15	5S-BNT900
5S-BNT901	12	24	6	0.3	0.15	2.70	0.78	275	79	1.11	113	6.7	64 400	129 400	5.4	0.4	0.010	16.0	14.7	20.0	14.2	13.2	22	0.3	0.15	5S-BNT901
5S-BNT902	15	28	7	0.3	0.15	4.10	1.22	415	124	1.60	163	6.6	54 000	108 400	6.4	0.6	0.014	19.0	17.4	24.0	17.2	16.2	26	0.3	0.15	5S-BNT902
5S-BNT903	17	30	7	0.3	0.15	4.30	1.35	440	138	1.78	182	6.7	49 400	99 100	6.7	0.8	0.015	21.0	19.4	26.0	19.2	18.2	28	0.3	0.15	5S-BNT903
5S-BNT904	20	37	9	0.3	0.15	6.20	2.07	630	211	2.74	279	6.8	40 700	81 800	8.4	1.4	0.033	25.5	23.5	31.4	22.5	21.5	34.5	0.3	0.15	5S-BNT904
5S-BNT905	25	42	9	0.3	0.15	6.65	2.46	675	251	3.25	330	7.0	34 600	69 600	9.0	1.7	0.039	30.5	28.5	36.5	27.5	26.5	39.5	0.3	0.15	5S-BNT905
5S-BNT906	30	47	9	0.3	0.15	7.05	2.84	715	290	3.80	385	7.2	30 100	60 500	9.7	1.9	0.044	35.5	33.5	41.5	32.5	31.5	44.5	0.3	0.15	5S-BNT906
5S-BNT907	35	55	10	0.6	0.3	11.1	4.40	1 140	445	5.80	590	7.0	24 400	49 300	11.1	2.8	0.063	41.2	38.5	48.8	39.5	37.5	50.5	0.6	0.3	5S-BNT907
5S-BNT908	40	62	12	0.6	0.3	11.8	5.05	1 210	515	6.70	685	7.2	21 600	43 500	12.9	4.5	0.100	47.0	44.4	55.0	44.5	42.5	57.5	0.6	0.3	5S-BNT908
5S-BNT909	45	68	12	0.6	0.3	14.7	6.35	1 490	650	8.45	865	7.2	19 500	39 300	13.6	5.2	0.110	52.1	49.1	60.9	49.5	48	63.5	0.6	0.3	5S-BNT909
5S-BNT910	50	72	12	0.6	0.3	15.5	7.15	1 580	730	9.55	975	7.3	18 000	36 400	14.2	6.2	0.110	56.6	53.6	65.4	54.5	52.5	67.5	0.6	0.3	5S-BNT910
5S-BNT911	55	80	13	1	0.6	16.2	8.00	1 650	820	10.7	1 090	7.4	16 000	32 000	15.6	7.8	0.160	63.2	60.1	71.8	60.5	59.5	74.5	1	0.6	5S-BNT911
5S-BNT912	60	85	13	1	0.6	16.9	8.85	1 730	900	11.8	1 200	7.5	14 900	29 800	16.3	8.3	0.170	68.1	65.1	76.9	65.5	64.5	79.5	1	0.6	5S-BNT912
5S-BNT913	65	90	13	1	0.6	17.1	9.30	1 750	945	12.4	1 270	7.5	13 900	27 900	17.0	8.9	0.190	73.1	70.1	81.9	70.5	69.5	84.5	1	0.6	5S-BNT913

1) Minimum allowable value for corner radius dimension r or r_1 .

Angular Contact Ball Bearings for Radial Loads

Dimension Tables



Dynamic equivalent radial load
 $P_r = X F_r + Y F_a$

$i \cdot f_0 \cdot F_a$	e	Single row / Tandem				Back-to-back / Face-to-face			
		$F_a/F_r \leq e$		$F_a/F_r > e$		$F_a/F_r \leq e$		$F_a/F_r > e$	
		X	Y	X	Y	X	Y	X	Y
C_{0r}									
0.178	0.35				1.57			1.76	2.56
0.357	0.36				1.53			1.71	2.48
0.714	0.38				1.46			1.64	2.38
1.07	0.4				1.42			1.59	2.31
1.43	0.41	1	0	0.44	1.38	1	1.55	0.72	2.25
2.14	0.43				1.33			1.49	2.16
3.57	0.44				1.25			1.4	2.03
5.35	0.47				1.18			1.32	1.92
7.14	0.49				1.13			1.26	1.83

Static equivalent radial load

$P_{0r} = X_0 F_r + Y_0 F_a$

Single row / Tandem		Back-to-back / Face-to-face	
X_0	Y_0	X_0	Y_0
0.52	0.54	1.04	1.08

When $P_{0r} < F_r$ with single-row or tandem arrangement, $P_{0r} = F_r$.

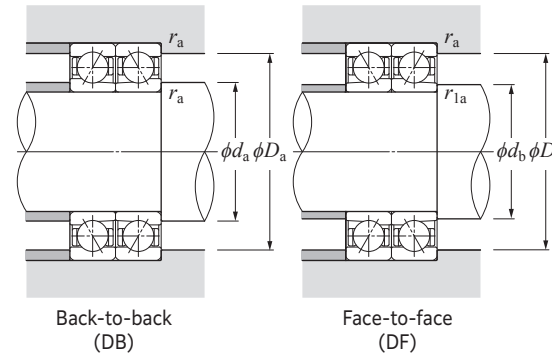

Angular Contact Ball Bearings for Radial Loads

Dimension Tables



Angular contact ball bearings for grinding machines / motors (ceramic ball spec.)
5S-BNT0 type

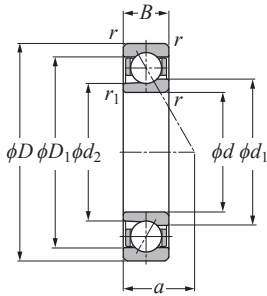

Contact angle 15° d 10–70 mm

Part number	Boundary dimensions					Basic load ratings				Allowable axial load		Factor f_0	Allowable speed		Load center a mm	Internal free space cm^3 (approx.)	Mass kg (approx.)	Reference dimensions			Abutment and fillet dimensions					Part number		
	mm					dynamic kN	static kN	dynamic kgf	static kgf	(static) kN	kgf		grease lubrication	oil lubrication				d_1	d_2	D_1	mm							
	d	D	B	$r_s \min^{1)}$	$r_{1s} \min^{1)}$	C_r	C_{0r}	C_r	C_{0r}				min	min							D_a max	r_{as} max	r_{1as} max					
5S-BNT000	10	26	8	0.3	0.15	4.15	1.01	425	103	1.31	133	5.7	70	100	140	200	6.5	0.9	0.013	14.6	13.0	21.0	12.5	11.2	23.5	0.3	0.15	5S-BNT000
5S-BNT001	12	28	8	0.3	0.15	4.60	1.20	470	122	1.57	160	6.1	61	200	122	400	6.8	1.0	0.018	17.4	15.6	23.5	14.5	13.2	25.5	0.3	0.15	5S-BNT001
5S-BNT002	15	32	9	0.3	0.15	5.30	1.54	540	157	2.02	206	6.4	53	400	106	800	7.7	1.3	0.026	20.4	18.5	26.5	17.5	16.2	29.5	0.3	0.15	5S-BNT002
5S-BNT003	17	35	10	0.3	0.15	6.55	1.87	665	191	2.45	250	6.3	48	300	96	500	8.5	1.8	0.029	22.2	20.2	29.6	19.5	18.2	32.5	0.3	0.15	5S-BNT003
5S-BNT004	20	42	12	0.6	0.3	8.90	2.74	905	279	3.60	365	6.4	39	800	79	700	10.3	3.0	0.050	27.4	24.9	35.5	24.5	22.5	37.5	0.6	0.3	5S-BNT004
5S-BNT005	25	47	12	0.6	0.3	9.90	3.35	1 010	345	4.45	455	6.7	34	900	69	700	10.9	3.5	0.060	31.8	29.4	40.6	29.5	27.5	42.5	0.6	0.3	5S-BNT005
5S-BNT006	30	55	13	1	0.6	12.8	4.65	1 310	475	6.15	630	6.8	29	200	58	400	12.3	4.3	0.10	38.4	35.5	47.8	35.5	34.5	49.5	1	0.6	5S-BNT006
5S-BNT007	35	62	14	1	0.6	16.2	6.20	1 650	630	8.20	835	6.8	23	500	46	900	13.6	6.5	0.13	43.4	40.2	53.8	40.5	39.5	56.5	1	0.6	5S-BNT007
5S-BNT008	40	68	15	1	0.6	17.4	7.20	1 780	735	9.55	975	7.0	21	100	42	100	14.8	8.0	0.16	48.8	45.7	59.4	45.5	44.5	62.5	1	0.6	5S-BNT008
5S-BNT009	45	75	16	1	0.6	20.7	8.75	2 110	890	11.6	1 180	7.0	19	000	37	900	16.1	9.6	0.21	54.2	50.9	65.6	50.5	49.5	69.5	1	0.6	5S-BNT009
5S-BNT010	50	80	16	1	0.6	22.0	9.90	2 240	1 010	13.2	1 340	7.1	17	500	35	000	16.8	11	0.24	59.6	55.9	70.2	55.5	54.5	74.5	1	0.6	5S-BNT010
5S-BNT011	55	90	18	1.1	0.6	28.9	13.0	2 950	1 320	17.2	1 760	7.0	15	500	31	000	18.8	16	0.35	66.1	61.8	79.1	62	59.5	83	1	0.6	5S-BNT011
5S-BNT012	60	95	18	1.1	0.6	29.7	13.9	3 050	1 420	18.4	1 880	7.1	14	500	29	000	19.5	19	0.36	71.1	66.8	84.1	67	64.5	88	1	0.6	5S-BNT012
5S-BNT013	65	100	18	1.1	0.6	31.5	15.5	3 200	1 580	20.7	2 110	7.2	13	600	27	300	20.2	20	0.37	75.2	71.8	89.8	72	69.5	93	1	0.6	5S-BNT013
5S-BNT014	70	110	20	1.1	0.6	39.5	19.5	4 050	1 990	25.9	2 640	7.1	12	500	25	000	22.2	27	0.50	82.3	77.7	97.9	77	74.5	103	1	0.6	5S-BNT014

1) Minimum allowable value for corner radius dimension r or r_1 .

Angular Contact Ball Bearings for Radial Loads

Dimension Tables



Dynamic equivalent radial load
 $P_r = X F_r + Y F_a$

$i \cdot f_0 \cdot F_a$	e	Single row / Tandem				Back-to-back / Face-to-face					
		$F_a/F_r \leq e$		$F_a/F_r > e$		$F_a/F_r \leq e$		$F_a/F_r > e$			
		X	Y	X	Y	X	Y	X	Y		
0.178	0.35				1.57			1.76			2.56
0.357	0.36				1.53			1.71			2.48
0.714	0.38				1.46			1.64			2.38
1.07	0.4				1.42			1.59			2.31
1.43	0.41	1	0	0.44	1.38	1	1.55	0.72	1.55	0.72	2.25
2.14	0.43				1.33			1.49			2.16
3.57	0.44				1.25			1.4			2.03
5.35	0.47				1.18			1.32			1.92
7.14	0.49				1.13			1.26			1.83

Static equivalent radial load

$P_{0r} = X_0 F_r + Y_0 F_a$

Single row / Tandem		Back-to-back / Face-to-face	
X_0	Y_0	X_0	Y_0
0.52	0.54	1.04	1.08

When $P_{0r} < F_r$ with single-row or tandem arrangement, $P_{0r} = F_r$.

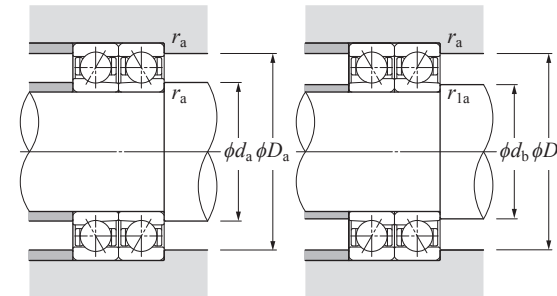

Back-to-back (DB)

Face-to-face (DF)

Angular Contact Ball Bearings for Radial Loads

Dimension Tables



Angular contact ball bearings for grinding machines / motors (ceramic ball spec.)
5S BNT2 type

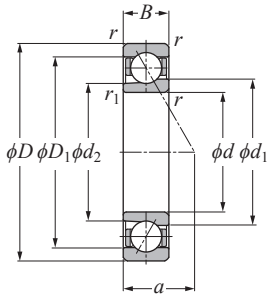

Contact angle 15° d 10–80 mm

Part number	Boundary dimensions					Basic load ratings				Allowable axial load		Factor f_0	Allowable speed		Load center mm a	Internal free space cm^3 (approx.)	Mass kg (approx.)	Reference dimensions			Abutment and fillet dimensions					Part number
	mm					dynamic kN	static kN	dynamic kgf	static kgf	(static) kN	kgf		grease lubrication min^{-1}	oil lubrication min^{-1}				d_1	d_2	D_1	mm					
	d	D	B	$r_s \min^{-1}$	$r_{1s} \min^{-1}$	C_r	C_{0r}	C_r	C_{0r}				(static)	f_0												
5S-BNT200	10	30	9	0.6	0.3	4.60	1.19	465	121	1.55	158	6.0	63 000	126 000	7.2	1.1	0.017	17.0	15.0	23.0	14.5	12.5	25.5	0.6	0.3	5S-BNT200
5S-BNT201	12	32	10	0.6	0.3	6.00	1.58	610	161	2.05	209	5.9	57 300	114 500	8.0	1.5	0.021	18.4	16.2	26.0	16.5	14.5	27.5	0.6	0.3	5S-BNT201
5S-BNT202	15	35	11	0.6	0.3	7.60	2.05	775	210	2.67	272	5.9	50 400	100 800	8.9	2.2	0.030	20.8	18.4	29.4	19.5	17.5	30.5	0.6	0.3	5S-BNT202
5S-BNT203	17	40	12	0.6	0.3	9.45	2.63	965	268	3.40	350	5.9	43 800	87 500	9.9	2.9	0.046	24.2	21.4	33.6	21.5	19.5	35.5	0.6	0.3	5S-BNT203
5S-BNT204	20	47	14	1	0.6	12.4	3.70	1 260	380	4.85	495	6.1	36 500	73 000	11.7	4.6	0.080	29.4	26.2	39.4	25.5	24.5	41.5	1	0.6	5S-BNT204
5S-BNT205	25	52	15	1	0.6	14.1	4.65	1 430	475	6.10	625	6.4	32 300	64 600	12.8	6.1	0.11	33.8	30.7	44.2	30.5	29.5	46.5	1	0.6	5S-BNT205
5S-BNT206	30	62	16	1	0.6	19.5	6.70	1 990	680	8.80	895	6.4	27 100	54 200	14.3	8.3	0.18	40.6	36.6	52.6	35.5	34.5	56.5	1	0.6	5S-BNT206
5S-BNT207	35	72	17	1.1	0.6	25.7	9.05	2 620	925	11.9	1 210	6.3	21 300	42 500	15.8	10	0.25	46.8	42.0	60.6	42	39.5	65	1	0.6	5S-BNT207
5S-BNT208	40	80	18	1.1	0.6	31.0	11.4	3 150	1 170	15.0	1 530	6.4	19 000	37 900	17.2	13	0.33	53.0	47.7	67.0	47	44.5	73	1	0.6	5S-BNT208
5S-BNT209	45	85	19	1.1	0.6	34.5	13.1	3 500	1 330	17.2	1 750	6.5	17 500	35 000	18.3	16	0.37	57.3	51.9	73.0	52	49.5	78	1	0.6	5S-BNT209
5S-BNT210	50	90	20	1.1	0.6	36.5	14.4	3 700	1 470	19.0	1 940	6.6	16 300	32 500	19.5	20	0.39	62.2	56.8	78.0	57	54.5	83	1	0.6	5S-BNT210
5S-BNT211	55	100	21	1.5	1	45.0	18.1	4 550	1 850	23.9	2 440	6.6	14 500	28 900	21.0	25	0.52	69.0	62.8	86.4	63.5	60.5	91.5	1.5	1	5S-BNT211
5S-BNT212	60	110	22	1.5	1	54.0	22.4	5 550	2 290	29.5	3 000	6.6	12 900	25 900	22.8	32	0.65	77.0	70.2	96.4	68.5	65.5	101.5	1.5	1	5S-BNT212
5S-BNT213	65	120	23	1.5	1	59.0	24.9	6 050	2 530	33.0	3 350	6.6	12 100	24 200	24.1	37	0.86	82.5	75.3	102.5	73.5	70.5	111.5	1.5	1	5S-BNT213
5S-BNT214	70	125	24	1.5	1	64.5	27.3	6 550	2 790	36.0	3 650	6.6	11 500	23 000	25.2	47	0.91	87.0	79.5	108.0	78.5	75.5	116.5	1.5	1	5S-BNT214
5S-BNT215	75	130	25	1.5	1	67.0	29.8	6 850	3 050	39.5	4 000	6.7	10 800	21 600	26.6	54	0.98	93.0	85.5	114.5	83.5	80.5	121.5	1.5	1	5S-BNT215
5S-BNT216	80	140	26	2	1	78.5	35.0	8 000	3 600	46.5	4 750	6.7	10 200	20 400	27.9	58	1.21	98.1	90.4	122.0	90	85.5	130	2	1	5S-BNT216

1) Minimum allowable value for corner radius dimension r or r_1 .

Angular Contact Ball Bearings for Radial Loads

Dimension Tables



Dynamic equivalent radial load
 $P_r = X F_r + Y F_a$

$i f_0 F_a$	C_{0r}	e	Single row / Tandem				Back-to-back / Face-to-face				
			$F_a/F_r \leq e$		$F_a/F_r > e$		$F_a/F_r \leq e$		$F_a/F_r > e$		
			X	Y	X	Y	X	Y	X	Y	
0.178	0.35					1.57	1.76			2.56	
0.357	0.36					1.53	1.71			2.48	
0.714	0.38					1.46	1.64			2.38	
1.07	0.4					1.42	1.59			2.31	
1.43	0.41	1	0	0.44		1.38	1.55	0.72		2.25	
2.14	0.43					1.33	1.49			2.16	
3.57	0.44					1.25	1.4			2.03	
5.35	0.47					1.18	1.32			1.92	
7.14	0.49					1.13	1.26			1.83	

Static equivalent radial load
 $P_{0r} = X_0 F_r + Y_0 F_a$

Single row / Tandem		Back-to-back / Face-to-face	
X_0	Y_0	X_0	Y_0
0.52	0.54	1.04	1.08

When $P_{0r} < F_r$ with single-row or tandem arrangement, $P_{0r} = F_r$.

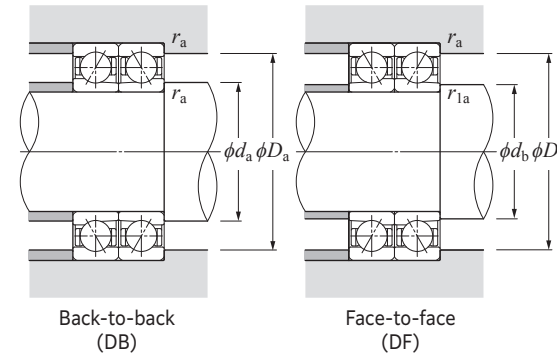



Main Spindle Bearings

10. Cylindrical Roller Bearings CONTENTS

10.1	Double-row cylindrical roller bearings	252
10.2	Single-row cylindrical roller bearings	253
10.3	Bearing designations	254
10.4	Accuracy of tapered bore	255
10.5	Accuracy of cylindrical roller bearings	256
10.6	Radial internal clearance of cylindrical roller bearings	258
10.7	Recommended fits of high-precision cylindrical roller bearings	260
10.8	Recommended lubrication specifications	261
10.9	Ultra high speed double-row cylindrical roller bearings	
	NN30HSRT6 type	262
10.10	Ultra high speed single-row cylindrical roller bearings	
	N10HSRT6 type	264
10.11	Eco-friendly air-oil lubricated ultra high speed single-row cylindrical roller bearings N10HSLT6 type	268
Dimension Tables		
	Double-row cylindrical roller bearings	270
	High speed single-row cylindrical roller bearings	276
	Ultra high speed single-row cylindrical roller bearings	280
	Eco-friendly ultra high speed single-row cylindrical roller bearings	282
10.12	Taper gauge and mounted internal clearance adjustment gauge for NTN precision cylindrical roller bearings	284
	Dimension table for taper gauge	284
	Dimension table for mounted internal clearance adjustment gauge	285

10. Cylindrical Roller Bearings

In a cylindrical roller bearing, the rollers and raceways are in line contact. Consequently this type of bearing can support a larger radial load than a point-contact ball bearing. Also, its design is suitable for high speed operation.

A cylindrical roller bearing used for the main spindle of a machine tool can have either a double- or single-row configuration, and certain variants have a tapered bore so the radial internal clearance can be adjusted.

10.1 Double-row cylindrical roller bearings

Double-row cylindrical roller bearings are available in two types, NN and NNU, and two series, 30 and 49. The rollers in the NN type bearing are guided by the ribs of the inner ring. The rollers in the NNU type bearing are guided by the ribs of the outer ring. Bearings are available with either a tapered bore (which allows adjustment of radial internal clearance of bearing) or a standard cylindrical bore.

The bearings come in two types, standard type and high speed HS type. Standard cage is machined brass.

The NN30 type bearing, with a bore diameter from 65 to 140 mm, has an optimized internal specification and PEEK resin cage. This allows for high speed and longer life, and is available as a high speed NN30HST6 and as an ultra high speed ULTAGE series NN30HSRT6 type.

All of these bearing types can be lubricated with either grease or air-oil.

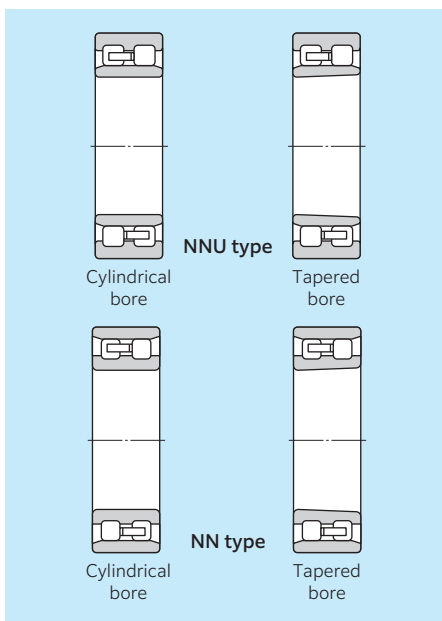

Fig. 10.1

10.2 Single-row cylindrical roller bearings

Single-row cylindrical roller bearings are available in two types, high speed N10HS type and ultra high speed N10HSRT6 type. The N10HS type bearings have high strength machined brass cages, while the N10HSR type bearings have PEEK resin cages, which can be used for both grease lubrication and air-oil lubrication. The eco-friendly N10HSLT6 type is a variation from the high speed N10HSRT6 type bearing and can be used with air-oil lubrication only.

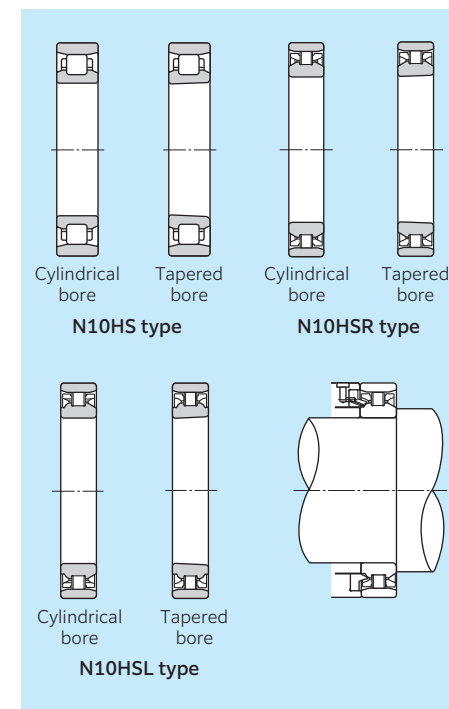

Fig. 10.2

10.3 Bearing designations

NN49, 30, NNU49 types

NN 30 20 HSR T6 K C0NA P4

- Precision class**
P5: JIS Class 5 P2: JIS Class 2
P4: JIS Class 4 UP: Special high precision
- Internal clearance code**
See Table 10.4 through Table 10.6
- External configuration code**
K: Bore diameter tapered bore, taper ratio 1/12
No code: Bore diameter cylindrical bore
- Cage code**
No code: Machined brass cage
T6: PEEK resin cage
- Internal modification code**
No code: Standard specification
HS: High speed specification
HSR: Ultra high speed specification
- Bore diameter code**
- Dimension series code**
- Bearing type code**
NN: Double-row, inner ring with rib
NNU: Double-row, outer ring with rib

N10 type

N 10 20 HSR T6 K C0NA P4

- Cage code**
T6: PEEK resin cage (HSR type)
No code: High strength machined brass cage
- Internal modification code**
HS: High speed specification
HSR: Ultra high speed specification
- Bearing type code**
N: Single-row, inner ring with rib

N10HSL type

N 10 20 HSL T6 K C0NA P4 +TKZ

- Spacer code** (Eco- friendly nozzle)
- Cage code**
T6: PEEK resin cage
- Internal modification code**

(Note) N10HSL: Bearing series code
TKZ: Eco-friendly nozzle, or spacer with nozzle (for N10HSL)

10.4 Accuracy of tapered bore

NTN specifies the accuracies of tapered bores conforming with JIS Classes 4 and 2 as shown in Table 10.1. Poor accuracies of the tapered bore lead to misalignment of the inner ring, causing poor performance, premature seizure and spalling. Use of a taper gauge is

recommended for higher accuracy of the main spindle. Refer to "6 Handling of Bearings, 6.8 Tapered bore cylindrical roller bearing and main spindle taper angle" in the Technical Data section for more information on taper angle.

Table 10.1 Tolerance of tapered bore bearings

Unit: μm

d (mm)	Δ _{dmp}	Δ _{d1mp} - Δ _{dmp} (approx.)				V _{dsp}	
		Class 4 high	Class 2 low	Class 4 high	Class 2 low	Class 4 max	Class 2 max
18 30	+10 0	+ 6 0	+ 3 0	2.5	1.5		
30 50	+12 0	+ 7 0	+3.5 0	2.5	1.5		
50 80	+15 0	+ 8 0	+ 4 0	3	2		
80 120	+20 0	+10 0	+ 5 0	4	2.5		
120 180	+25 0	+12 0	+ 6 0	5	3.5		
180 250	+29 0	+14 0	+ 7 0	7	4.5		
250 315	+32 0	— —	+10 0	— —	8	—	
315 400	+36 0	— —	+12 0	— —	9	—	
400 500	+40 0	— —	+14 0	— —	10	—	

Note: NTN standard

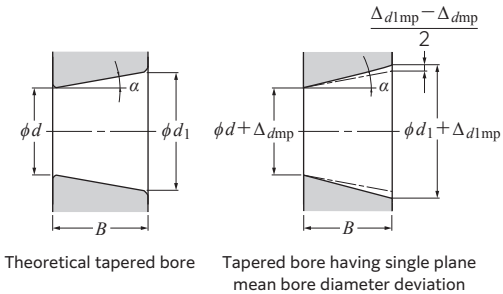

Tolerance of 1/12 taper angle $4^{\circ}46'18.8'' \begin{smallmatrix} +24'' \\ 0 \end{smallmatrix}$
 $\alpha = 2^{\circ}23'9.4''$

$$d_1 = d + \frac{1}{12} B$$

Δ_{dmp} : Dimensional difference of the mean bore diameter within the flat surface at the theoretical small end of the tapered bore

Δ_{d1mp} : Dimensional difference of the mean bore diameter within the flat surface at the theoretical large end of the tapered bore

V_{dsp} : Variation of bore diameter in a single plane
B : Nominal inner ring width

Fig. 10.3

10.5 Accuracy of cylindrical roller bearings

Table 10.2 Inner rings

Nominal bore diameter <i>d</i>	Deviation of mean bore diameter in a single plane						Variation of bore diameter in a single plane						Variation of mean bore diameter			Radial runout of inner ring of assembled bearing				
	Δ_{dmp}						V_{dsp}						V_{dmp}			K_{ia}				
	Class 5		Class 4 ¹⁾		Class 2 ¹⁾		Diameter series 9			Diameter series 0			Class 5			Class 4			Class 2	
mm over	incl.	high	low	high	low	high	low	max	Class 5	Class 4	Class 2	max	Class 5	Class 4	Class 2	max	Class 5	Class 4	Class 2	max
18	30	0	-6	0	-5	0	-2.5	6	5	2.5	5	4	2.5	3	2.5	1.5	4	3	2.5	
30	50	0	-8	0	-6	0	-2.5	8	6	2.5	6	5	2.5	4	3	1.5	5	4	2.5	
50	80	0	-9	0	-7	0	-4	9	7	4	7	5	4	5	3.5	2	5	4	2.5	
80	120	0	-10	0	-8	0	-5	10	8	5	8	6	5	5	4	2.5	6	5	2.5	
120	150	0	-13	0	-10	0	-7	13	10	7	10	8	7	7	5	3.5	8	6	2.5	
150	180	0	-13	0	-10	0	-7	13	10	7	10	8	7	7	5	3.5	8	6	5	
180	250	0	-15	0	-12	0	-8	15	12	8	12	9	8	8	6	4	10	8	5	
250	315	0	-18	—	—	—	—	18	—	—	14	—	—	9	—	—	13	—	—	
315	400	0	-23	—	—	—	—	23	—	—	18	—	—	12	—	—	15	—	—	
400	500	—	—	—	—	—	—	—	—	—	—	—	—	—	—	—	—	—	—	

1) The dimensional difference Δ_{ds} of the measured bore diameter applied to Classes 4 and 2 is the same as the tolerance of dimensional difference Δ_{dmp} of the mean bore diameter within a plane.

Table 10.3 Outer rings

Nominal outside diameter <i>D</i>	Deviation of mean outside diameter in a single plane						Variation of outside diameter in a single plane						Variation of mean outside diameter			Radial runout of outer ring of assembled bearing				
	Δ_{Dmp}						V_{Dsp}						V_{Dmp}			K_{ea}				
	Class 5		Class 4 ²⁾		Class 2 ²⁾		Diameter series 9			Diameter series 0			Class 5			Class 4			Class 2	
mm over	incl.	high	low	high	low	high	low	max	Class 5	Class 4	Class 2	max	Class 5	Class 4	Class 2	max	Class 5	Class 4	Class 2	max
30	50	0	-7	0	-6	0	-4	7	6	4	5	5	4	4	3	2	7	5	2.5	
50	80	0	-9	0	-7	0	-4	9	7	4	7	5	4	5	3.5	2	8	5	4	
80	120	0	-10	0	-8	0	-5	10	8	5	8	6	5	5	4	2.5	10	6	5	
120	150	0	-11	0	-9	0	-5	11	9	5	8	7	5	6	5	2.5	11	7	5	
150	180	0	-13	0	-10	0	-7	13	10	7	10	8	7	7	5	3.5	13	8	5	
180	250	0	-15	0	-11	0	-8	15	11	8	11	8	8	8	6	4	15	10	7	
250	315	0	-18	0	-13	0	-8	18	13	8	14	10	8	9	7	4	18	11	7	
315	400	0	-20	0	-15	0	-10	20	15	10	15	11	10	10	8	5	20	13	8	
400	500	0	-23	—	—	—	—	23	—	—	17	—	—	12	—	—	23	—	—	
500	630	0	-28	—	—	—	—	28	—	—	21	—	—	14	—	—	25	—	—	
630	800	0	-35	—	—	—	—	35	—	—	26	—	—	18	—	—	30	—	—	

2) The dimensional difference Δ_{Ds} of the measured outside diameter applied to Classes 4 and 2 is the same as the tolerance of dimensional difference Δ_{Dmp} of the mean outside diameter within a plane.

Unit: μm

Perpendicularity of inner ring face with respect to the bore			Deviation of a single inner ring width				Variation of inner ring width		
S_d			Δ_{Bs}				V_{Bs}		
Class 5			Class 4		Class 2		Class 5		
Class 5	Class 4	Class 2	high	low	high	low	Class 5	Class 4	Class 2
max			max				max		
8	4	1.5	0	-120	0	-120	5	2.5	1.5
8	4	1.5	0	-120	0	-120	5	3	1.5
8	5	1.5	0	-150	0	-150	6	4	1.5
9	5	2.5	0	-200	0	-200	7	4	2.5
10	6	2.5	0	-250	0	-250	8	5	2.5
10	6	4	0	-250	0	-250	8	5	4
11	7	5	0	-300	0	-300	10	6	5
13	—	—	0	-350	—	—	13	—	—
15	—	—	0	-400	—	—	15	—	—
—	—	—	—	—	—	—	—	—	—

Unit: μm

Perpendicularity of outer ring outside surface with respect to the face			Deviation of a single outer ring width		Variation of outer ring width		
S_D			Δ_{Cs}		V_{Cs}		
Class 5			All classes		Class 5		
Class 5	Class 4	Class 2	max		Class 5	Class 4	Class 2
max			max		max		
8	4	1.5	Depends on tolerance of Δ_{Bs} in relation to d of the same bearing		5	2.5	1.5
8	4	1.5			6	3	1.5
9	5	2.5			8	4	2.5
10	5	2.5			8	5	2.5
10	5	2.5			8	5	2.5
11	7	4			10	7	4
13	8	5			11	7	5
13	10	7			13	8	7
15	—	—			15	—	—
18	—	—			18	—	—
20	—	—			20	—	—

10.6 Radial internal clearance of cylindrical roller bearings

■ Non-interchangeable radial internal clearance

Two types of radial internal clearance are available: non-interchangeable radial internal clearance for which the combination of outer ring and inner ring cannot be changed; and interchangeable radial internal clearance that allows for different outer ring and inner ring combinations. The clearances listed are common to both double-row and the single-row cylindrical roller bearings. For machine components including high-precision machine tool main spindle, bearings with

non-interchangeable radial internal clearance and a small clearance range are used. If a tapered bore bearing is used and the adjust required internal clearance is close to zero, use of clearance in the range C0NA and C1NA is recommended. Cylindrical bore bearings are also available in the form of a specialized product with non-interchangeable radial internal clearance, in which the internal clearance is further controlled over a small range after assembly. For details, contact NTN Engineering.

Table 10.4 Cylindrical bore bearings Unit: μm

Nominal bore diameter d (mm)		Cylindrical bore bearing					
		C1NA		C2NA		NA ¹⁾	
over	incl.	min	max	min	max	min	max
24	30	5	10	10	25	25	35
30	40	5	12	12	25	25	40
40	50	5	15	15	30	30	45
50	65	5	15	15	35	35	50
65	80	10	20	20	40	40	60
80	100	10	25	25	45	45	70
100	120	10	25	25	50	50	80
120	140	15	30	30	60	60	90
140	160	15	35	35	65	65	100
160	180	15	35	35	75	75	110
180	200	20	40	40	80	80	120
200	225	20	45	45	90	90	135
225	250	25	50	50	100	100	150
250	280	25	55	55	110	110	165
280	315	30	60	60	120	120	180
315	355	30	65	65	135	135	200
355	400	35	75	75	150	150	225
400	450	45	85	85	170	170	255
450	500	50	95	95	190	190	285

1) The code for normal internal clearance is "NA". Ex: N1006HSNA

Table 10.5 Tapered bore bearings Unit: μm

Nominal bore diameter d (mm)		Tapered bore bearing									
		C9NA ²⁾		C0NA ²⁾		C1NA ²⁾		C2NA		NA ¹⁾	
		min	max	min	max	min	max	min	max	min	max
24	30	5	10	10	20	10	25	25	35	40	50
30	40	5	12	10	20	12	25	25	40	45	55
40	50	5	15	10	20	15	30	30	45	50	65
50	65	5	15	10	20	15	35	35	50	55	75
65	80	10	20	15	30	20	40	40	60	70	90
80	100	10	25	20	35	25	45	45	70	80	105
100	120	10	25	20	35	25	50	50	80	95	120
120	140	15	30	25	40	30	60	60	90	105	135
140	160	15	35	30	45	35	65	65	100	115	150
160	180	15	35	30	45	35	75	75	110	125	165
180	200	20	40	30	50	40	80	80	120	140	180
200	225	20	45	35	55	45	90	90	135	155	200
225	250	25	50	40	65	50	100	100	150	170	215
250	280	25	55	40	65	55	110	110	165	185	240
280	315	30	60	45	75	60	120	120	180	205	265
315	355	30	65	45	75	65	135	135	200	225	295
355	400	35	75	50	90	75	150	150	225	255	330
400	450	45	85	60	100	85	170	170	255	285	370
450	500	50	95	70	115	95	190	190	285	315	410

1) The code for normal internal clearance is "NA". Ex: N1006HSKNA
2) Internal clearances C9NA, C0NA and C1NA apply to bearings of JIS Class 5 or higher.

■ Interchangeable radial internal clearance (cylindrical bore)

Table 10.6 Unit: μm

Nominal bore diameter d (mm)		C2		CN (Normal)		C3	
		min	max	min	max	min	max
24	30	0	25	20	45	35	60
30	40	5	30	25	50	45	70
40	50	5	35	30	60	50	80
50	65	10	40	40	70	60	90
65	80	10	45	40	75	65	100
80	100	15	50	50	85	75	110
100	120	15	55	50	90	85	125
120	140	15	60	60	105	100	145
140	160	20	70	70	120	115	165
160	180	25	75	75	125	120	170
180	200	35	90	90	145	140	195
200	225	45	105	105	165	160	220
225	250	45	110	110	175	170	235
250	280	55	125	125	195	190	260
280	315	55	130	130	205	200	275
315	355	65	145	145	225	225	305
355	400	100	190	190	280	280	370
400	450	110	210	210	310	310	410
450	500	110	220	220	330	330	440

■ Adjustment of clearance in tapered bore bearings

Mounted internal clearance of a tapered bore bearing can be adjusted by controlling the drive-up of the tapered bore onto the shaft. Two types of adjusting methods are available: repeated adjustment of spacer

width and adjustment with using a mounted internal clearance gauge. The clearance gauge is convenient for mass-production. Refer to "6. Handling of Bearings, 6.7 Clearance adjustment for cylindrical roller bearing" in the Technical Data section.

10.7 Recommended fits of high-precision cylindrical roller bearings

In order to maintain the high precision of the bearing at d_{mn} values less than 0.75×10^6 the fits listed in **Table 10.7** and **Table 10.8** are recommended [d_{mn} : pitch circle diameter across rolling elements (mm) multiplied by speed (min^{-1})].

Table 10.7 Shaft fits Unit: μm

Nominal bore diameter d (mm)		Fit between inner ring and shaft
over	incl.	
18	30	0- 4T
30	50	0- 5T
50	80	1T- 6T
80	120	1T- 6T
120	180	2T- 8T
180	250	2T- 8T
250	315	3T-10T
315	400	4T-11T

Note 1: Target the median value.
T: Tight (Interference) fit
Not applicable to tapered bore bearings

■ Fits of tapered bore bearings

When fitting a tapered bore bearing onto a shaft, carefully and thoroughly adjust the fit of the tapered bore to the shaft to maintain high precision of the bearing.

For details of taper angle adjustment refer to "6. Handling of Bearings, 6.8 Cylindrical roller bearing and main spindle taper angle" in the Technical Data section.

When the d_{mn} value is larger than 0.75×10^6 (d_{mn} value $\geq 0.75 \times 10^6$), consult **NTN Engineering** about the recommended fit. Expansion of the inner ring due to centrifugal force must be considered when determining shaft fit.

Table 10.8 Housing fits Unit: μm

Nominal outside diameter D (mm)		Fit between outer ring and housing
over	incl.	
30	50	0-3T
50	80	0-4T
80	120	0-4T
120	150	0-5T
150	180	0-5T
180	250	0-6T
250	315	0-7T
315	400	0-8T
400	500	0-9T

Note 1: Target the median value.
T: Tight (Interference) fit

10.8 Recommended lubrication specifications

Cylindrical roller bearings are usually used with grease lubrication or air-oil lubrication. Recommended lubrication specifications are described below.

■ Grease lubrication

● Recommended brand of grease

Refer to "7. Lubrication of Bearings, 7.1 Grease lubrication" in the Technical Data section.

● Recommended grease fill

10 to 15 % of the internal free space shown in the dimension tables

● Recommended grease packing method

Refer to "6. Handling of Bearings, 6.1 Cleaning and filling with grease" in the Technical Data section.

■ Air-oil lubrication

● Recommended location of nozzle

Refer to "7. Lubrication of Bearings, 7.2 Air-oil lubrication" in the Technical Data section.

● Recommended specifications of nozzle

Nozzle bore diameter.: From 1 to 1.5 mm
Number of nozzles: One nozzle for each bearing, depth of nozzle bore should be four to six times the nozzle diameter.

● Recommended specifications of air-oil

Oil type: Spindle oil
Viscosity grade: ISO VG from 10 to 32 (32 is preferable)

Table 10.9 Air and oil amount

Bearing type	d_{mn} value ($\times 10^6$)		Oil amount per shot cm^3	Lubrication interval min	Oil consumption cm^3/h	Recommended air consumption $\text{NL}/\text{min}^{1)}$
	Over	Incl.				
NN30	—	1.0	0.02	8	0.15	30 to 40
NN30HS	1.0	1.5		5	0.24	
N10HS	1.5	2.3		5	0.24	
N10HSRT6	1.5	2.3		5	0.24	
NN30HST6	—	1.7		15	0.08	20 to 40
NN30HSRT6	—	1.7		15	0.08	
N10HSL	—	2.3	10	0.12	20 to 40	

1) NL/min (Normal liter/minute) ... NL means the volume of air at 0 °C and 1 atmosphere.

10.9 ULTAGE Ultra high speed double-row cylindrical roller bearings
NN30HSRT6 type

NN30HSRT6 ultra high speed double-row cylindrical roller bearings have higher operating speeds with the same level of rigidity and capacity as the conventional series.

■ Features

1. Optimized internal design to realize high speed and low temperature rise.
2. PEEK resin cage is used for high speed under grease & air-oil lubrication and grease life.

■ Permissible speed range

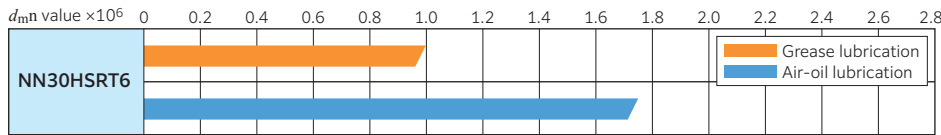

Notes) Permissible speed of each bearing (d_{mn} value) varies depending on the specifications of the machine for which the bearing is used (motor drive system, cooling system, and construction around the bearing). Consider the optimal choice referring to the above guideline, and then, contact NTN Engineering for technical assistance.

■ Cage design

Cage is made of PEEK which is very light and strong (see Photo 10.1).

By using a proven cage design made of PEEK material, less deformation of the cage is seen due to centrifugal force. As a result, the high speed operation of the bearing is improved. The grease life of the bearing is improved by including a pocket for grease in the cage.

■ Bearing specification

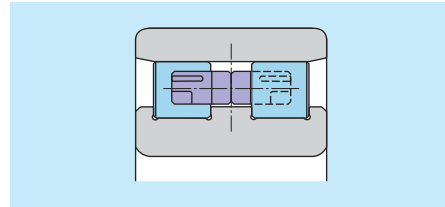

Fig. 10.4 NN30HSRT6 type



Photo 10.1 PEEK resin cage

■ Data/Operation test

d_{mn} value of 1.0×10^6 under grease lubrication and 1.75×10^6 under air-oil lubrication are realized by the optimized internal design (see Fig. 10.5, Fig. 10.6).

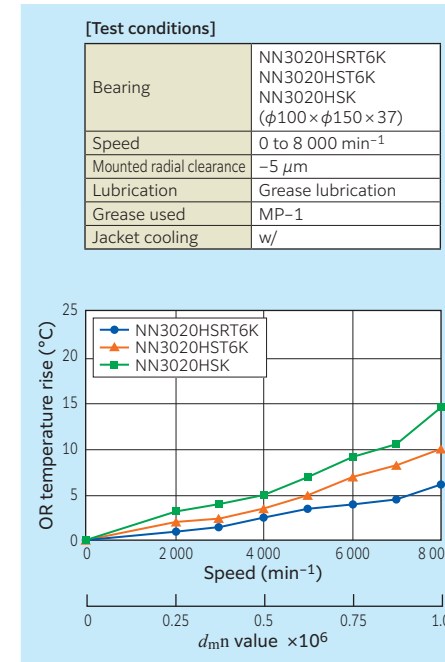

Fig. 10.5 Operation test results (grease lubrication with jacket cooling)

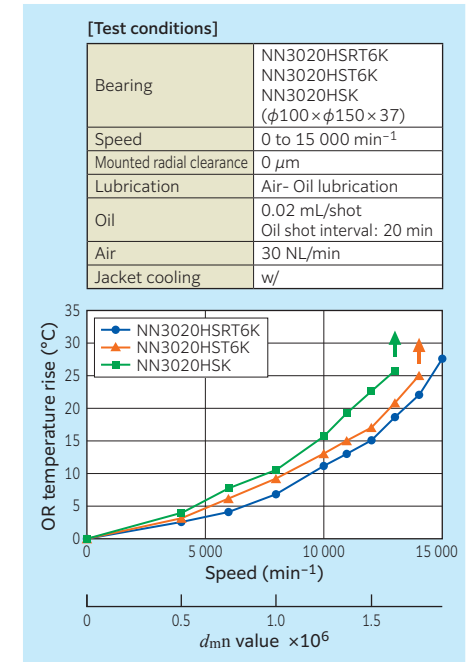

Fig. 10.6 Operation test results (air-oil lubrication with jacket cooling)

■ Data/Durability test

By including a pocket for grease in the cage, the NN30HSRT6K type is capable operating for 13 800 hours under a d_{mn} value of 1.0×10^6 (see Fig. 10.7).

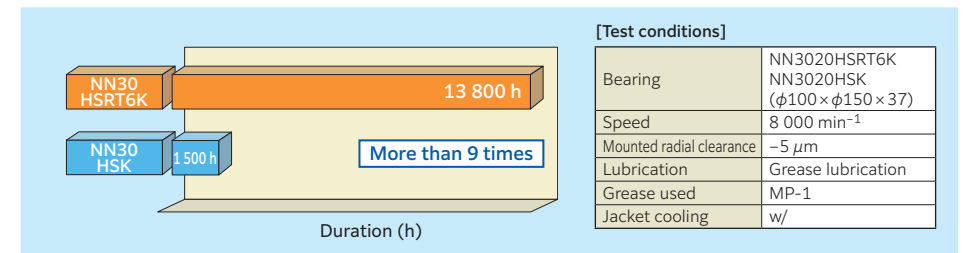

Fig. 10.7 Durability test results

10.10 **ULTAGE** Ultra high speed single-row cylindrical roller bearings
N10HSRT6 type

N10HSRT6 type cylindrical roller bearings have been designed for high speed operation.

■ Features

1. Optimized internal design allows high speed operation and limits temperature rise.
2. PEEK resin cage is suitable for high speed operation.

■ Bearing specification

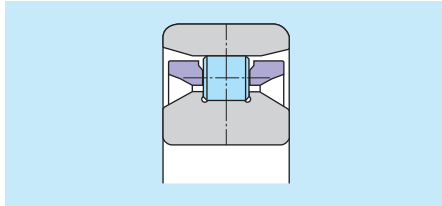
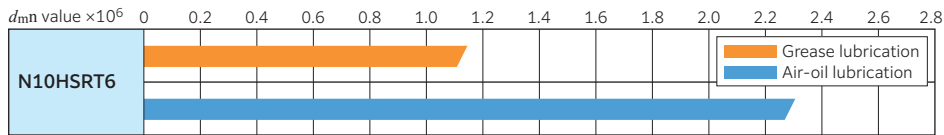

Fig. 10.8 N10HSRT6 type

■ Permissible speed range



Notes) Permissible speed of each bearing (d_{mn} value) varies depending on the specifications of the machine for which the bearing is used (motor drive system, cooling system, and construction around the bearing). Consider the optimal choice referring to the above guideline, and then, contact **NTN** Engineering for technical assistance.

■ Simplified main spindle configuration / adoption of simplified lubrication system

Due to an optimized internal structure, the N10HSR type bearings can reliably run at a higher speed with grease lubrication. The grease lubrication system greatly contributes to reduction in pollution of the surrounding environments by virtually eliminating oil mist (see Fig. 10.9).

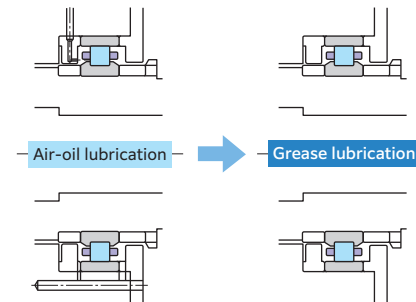

Capable of replacing air-oil lubricated bearings up to d_{mn} value of 1.15×10^6 .

Fig. 10.9 Modification of lubrication system

■ Simplified main spindle configuration / simplified main spindle rear structure

N10HSR (N10HSL) type bearings can replace angular contact ball bearings on the rear side of the main spindle. This arrangement decreases the number of bearing rows (two rows to one row) and eliminates the ball slide mechanism, greatly contributing to simplification of the rear structure (see Fig. 10.10).

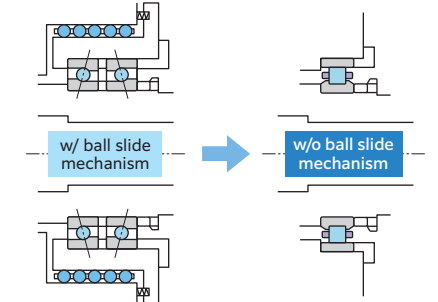

Capable of replacing angular contact ball bearings up to d_{mn} value of 2.3×10^6 [air-oil lubrication] or 1.15×10^6 [grease lubrication].

Fig. 10.10 Simplified main spindle rear structure

Main Spindle Bearings

Main Spindle Bearings

■ Data/High speed operation test

Due to an optimized internal design, the N10HSR type is capable of high speed operation with d_{mn} value of 1.15×10^6 [grease lubrication] or 2.3×10^6 [air-oil lubrication] (see Fig. 10.11, Fig. 10.12, Fig. 10.13, Fig. 10.14).

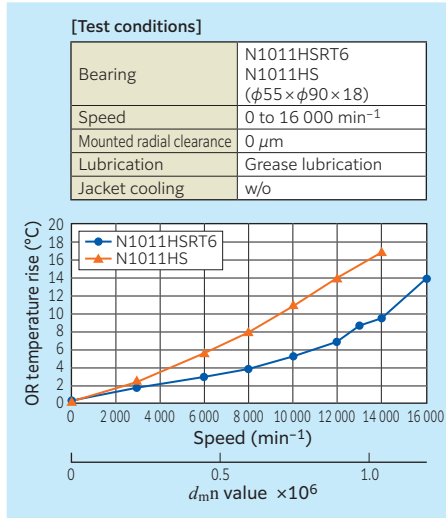

Fig. 10.11 High speed test results (grease lubrication without jacket cooling)

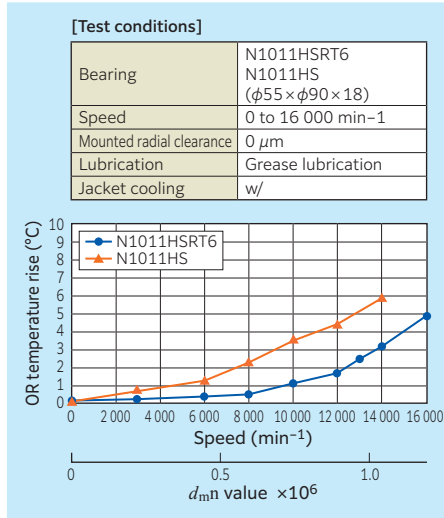

Fig. 10.12 High speed test results (grease lubrication with jacket cooling)

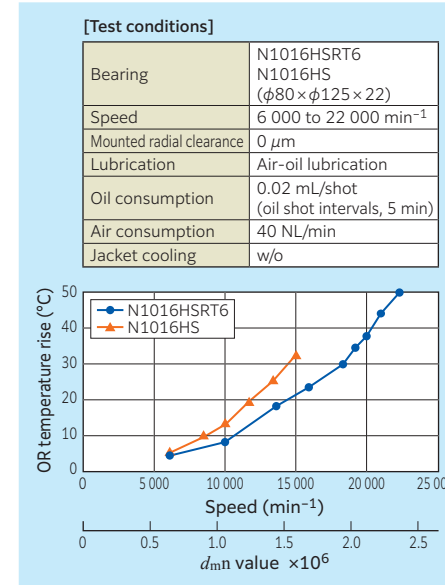

Fig. 10.13 High speed test results (air-oil lubrication without jacket cooling)

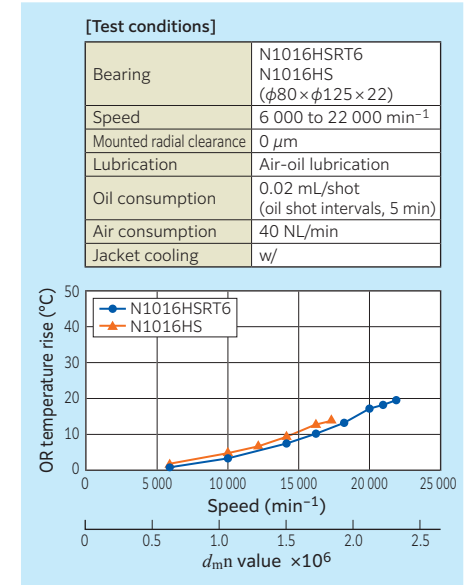

Fig. 10.14 High speed test results (air-oil lubrication with jacket cooling)

10.11 **ULTAGE** Eco-friendly air-oil lubricated ultra high speed single-row cylindrical roller bearings N10HSLT6 type

The eco-friendly air-oil lubricated N10HSLT6 type was developed by applying NTN's unique eco-conscious technology to the proven N10HSRT6 type bearing design. The N10HSLT6 type boasts limited emission of oil mist and reduced air and oil consumption. This improves operating environments, saves energy while allowing higher speed machining operation.

■ Features

1. Optimized internal design allows high speed operation and limits temperature rise.
2. Adoption of the eco-friendly nozzle design has led to:
 - Lower noise level (up to 7 dBA reduction)
 - 50 % reduction in air consumption
 - 50 % reduction in oil consumption.

■ Permissible speed range

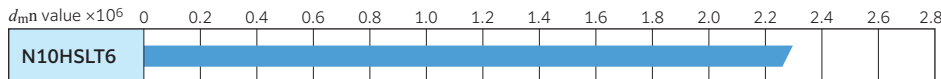

Notes) Permissible speed of each bearing (d_{mn} value) varies depending on the specifications of the machine for which the bearing is used (motor drive system, cooling system, and construction around the bearing). Consider the optimal choice referring to the above guideline, and then, contact NTN Engineering for technical assistance.

■ Bearing specification

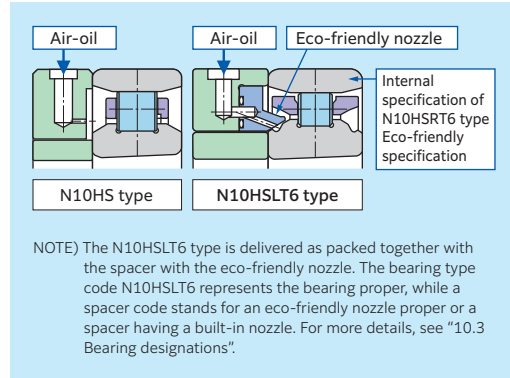

Fig. 10.15 N10HSLT6 type

■ Data/High speed operation test

Even with decreased air consumption and oil consumption, the N10HSL type bearings can reliably operate at high speed of d_{mn} value 2.3×10^6 (see Fig. 10.16, Fig. 10.17).

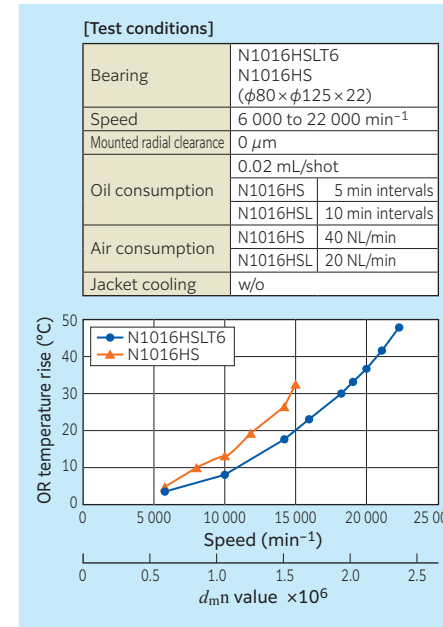

Fig. 10.16 High speed test results (without Jacket cooling)

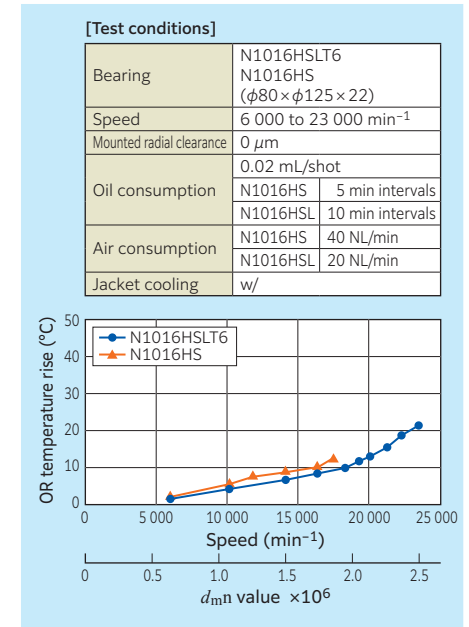
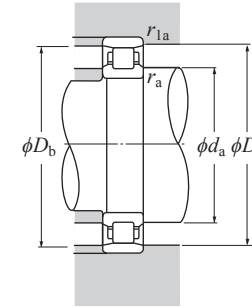
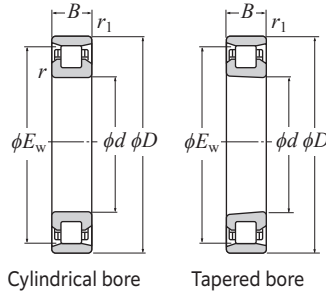

Fig. 10.17 High speed test results (with Jacket cooling)



Dynamic equivalent radial load
 $P_r = F_r$
 Static equivalent radial load
 $P_{0r} = F_r$

d 30–80 mm

Part number ^{1) 3)}		Boundary dimensions						Basic load ratings				Allowable speed		Abutment and fillet dimensions				Mass	Internal free space	Part number		
cylindrical bore	tapered bore	mm						dynamic	static	dynamic	static	min^{-1}		mm				(approx.)	cm^3	cylindrical bore	tapered bore	
		d	D	B	$r_s \text{ min}^{2)}$	$r_{1s} \text{ min}^{2)}$	E_w	C_r	C_{0r}	C_r	C_{0r}	grease lubrication	oil lubrication	$d_a \text{ min}$	$D_b \text{ max}$	$r_{as} \text{ min}$	$r_{1as} \text{ max}$	kg	cylindrical bore			
N1006HS	N1006HSK	30	55	13	1	0.6	48.5	19.1	17.6	1 950	1 790	20 500	32 100	35	50	49	1	0.6	0.143	4.33	N1006HS	N1006HSK
N1007HS	N1007HSK	35	62	14	1	0.6	55	23.5	22.5	2 390	2 300	18 000	28 200	40	57	56	1	0.6	0.190	5.06	N1007HS	N1007HSK
N1008HS	N1008HSK	40	68	15	1	0.6	61	26.9	26.3	2 750	2 680	16 100	25 300	45	63	62	1	0.6	0.235	7.10	N1008HS	N1008HSK
N1009HS	N1009HSK	45	75	16	1	0.6	67.5	32.5	32.5	3 300	3 350	14 500	22 800	50	70	69	1	0.6	0.298	8.85	N1009HS	N1009HSK
N1010HS	N1010HSK	50	80	16	1	0.6	72.5	33.0	34.5	3 400	3 550	13 400	21 100	55	75	74	1	0.6	0.323	10.8	N1010HS	N1010HSK
N1011HS	N1011HSK	55	90	18	1.1	1	81	43.5	46.0	4 400	4 700	12 100	18 900	61.5	83.5	82	1	1	0.473	15.0	N1011HS	N1011HSK
N1012HS	N1012HSK	60	95	18	1.1	1	86.1	44.5	48.5	4 550	4 950	11 300	17 700	66.5	88.5	87	1	1	0.505	15.3	N1012HS	N1012HSK
N1013HS	N1013HSK	65	100	18	1.1	1	91	47.0	53.5	4 800	5 450	10 600	16 600	71.5	93.5	92	1	1	0.538	19.0	N1013HS	N1013HSK
N1014HS	N1014HSK	70	110	20	1.1	1	100	57.5	65.5	5 850	6 700	9 700	15 200	76.5	103.5	101	1	1	0.745	22.0	N1014HS	N1014HSK
N1015HS	N1015HSK	75	115	20	1.1	1	105	59.0	69.0	6 000	7 050	9 200	14 400	81.5	108.5	106	1	1	0.787	26.5	N1015HS	N1015HSK
N1016HS	N1016HSK	80	125	22	1.1	1	113	70.5	82.0	7 200	8 400	8 500	13 400	86.5	118.5	114	1	1	1.05	31.1	N1016HS	N1016HSK

1) A bearing number with suffix K indicates a tapered bore bearing (taper ratio 1/12).
 2) Minimum allowable value for corner radius dimension r or r_1 .
 3) N10HS differs from standard N10 in internal construction.

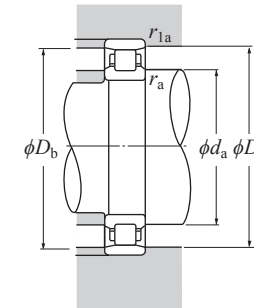
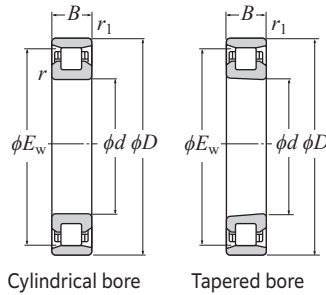

Dynamic equivalent radial load
 $P_r = F_r$
 Static equivalent radial load
 $P_{0r} = F_r$

d 85-160 mm

Part number ^{1) 3)}		Boundary dimensions						Basic load ratings				Allowable speed		Abutment and fillet dimensions				Mass (approx.)	Internal free space	Part number		
cylindrical bore	tapered bore	mm						dynamic	static	dynamic	static	min ⁻¹		mm				kg	cm ³	cylindrical bore	tapered bore	
		d	D	B	r _{s min²⁾}	r _{1s min²⁾}	E _w	C _r	C _{0r}	C _r	C _{0r}	grease lubrication	oil lubrication	d _{a min}	D _{b max}	r _{as min}	r _{1as max}					cylindrical bore
N1017HS	N1017HSK	85	130	22	1.1	1	118	72.0	86.0	7 350	8 800	8 100	12 800	91.5	123.5	119	1	1	1.10	33.4	N1017HS	N1017HSK
N1018HS	N1018HSK	90	140	24	1.5	1.1	127	87.0	105	8 900	10 700	7 600	11 900	98	132	129	1.5	1	1.43	40.0	N1018HS	N1018HSK
N1019HS	N1019HSK	95	145	24	1.5	1.1	132	89.0	110	9 100	11 200	7 300	11 400	103	137	134	1.5	1	1.50	46.5	N1019HS	N1019HSK
N1020HS	N1020HSK	100	150	24	1.5	1.1	137	91.0	115	9 300	11 700	7 000	11 000	108	142	139	1.5	1	1.55	53.5	N1020HS	N1020HSK
N1021HS	N1021HSK	105	160	26	2	1.1	146	121	149	12 300	15 200	6 600	10 400	114	151	148	2	1	1.96	56.2	N1021HS	N1021HSK
N1022HS	N1022HSK	110	170	28	2	1.1	155	139	173	14 200	17 700	6 200	9 800	119	161	157	2	1	2.44	68.8	N1022HS	N1022HSK
N1024HS	N1024HSK	120	180	28	2	1.1	165	142	182	14 500	18 500	5 800	9 100	129	171	167	2	1	2.61	87.5	N1024HS	N1024HSK
N1026HS	N1026HSK	130	200	33	2	1.1	182	173	220	17 700	22 400	5 300	8 300	139	191	183	2	1	3.95	118	N1026HS	N1026HSK
N1028HS	N1028HSK	140	210	33	2	1.1	192	182	240	18 600	24 400	5 000	7 800	149	201	194	2	1	4.19	130	N1028HS	N1028HSK
N1030HS	N1030HSK	150	225	35	2.1	1.5	206	205	273	20 900	27 800	4 700	7 300	161	214	208	2	1.5	5.10	151	N1030HS	N1030HSK
N1032HS	N1032HSK	160	240	38	2.1	1.5	219	228	305	23 300	31 500	4 400	6 900	171	229	221	2	1.5	6.30	172	N1032HS	N1032HSK

1) A bearing number with suffix K indicates a tapered bore bearing (taper ratio 1/12).
 2) Minimum allowable value for corner radius dimension r or r₁.
 3) N10HS differs from standard N10 in internal construction.

Main Spindle Bearings

Main Spindle Bearings

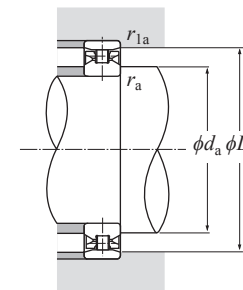
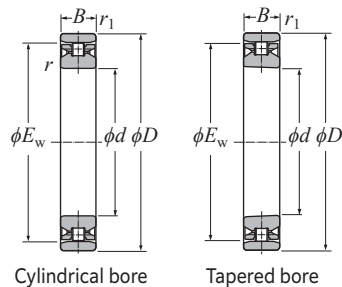

Dynamic equivalent radial load
 $P_r = F_r$

Static equivalent radial load
 $P_{0r} = F_r$

d 45-100 mm

Part number		Boundary dimensions						Basic load ratings				Allowable speed		Abutment and fillet dimensions				Internal free space	Part number		
cylindrical bore	tapered bore	mm						dynamic kN	static	dynamic	static	min ⁻¹		mm				cm ³	cylindrical bore	tapered bore	
		d	D	B	r _{s min} ¹⁾	r _{1s min} ¹⁾	E _w	C _r	C _{0r}	C _r	C _{0r}	grease lubrication	oil lubrication	d _{a min}	D _{b max}	r _{as max}	r _{1as max}				
N1009HSRT6	N1009HSRT6K	45	75	16	1	0.6	67.5	23.3	22.5	2 380	2 290	18 900	37 700	50	70	69	1	0.6	9.2	N1009HSRT6	N1009HSRT6K
N1011HSRT6	N1011HSRT6K	55	90	18	1.1	1	81	26.7	28.7	2 730	2 930	15 400	30 900	61.5	83.5	82	1	1	15.7	N1011HSRT6	N1011HSRT6K
N1012HSRT6	N1012HSRT6K	60	95	18	1.1	1	86.1	26.4	28.9	2 700	2 950	14 400	28 900	66.5	88.5	87	1	1	17.0	N1012HSRT6	N1012HSRT6K
N1013HSRT6	N1013HSRT6K	65	100	18	1.1	1	91	28.1	32.0	2 860	3 250	13 600	27 200	71.5	93.5	92	1	1	17.9	N1013HSRT6	N1013HSRT6K
N1014HSRT6	N1014HSRT6K	70	110	20	1.1	1	100	32.5	37.5	3 300	3 850	12 400	24 700	76.5	103.5	101	1	1	23.3	N1014HSRT6	N1014HSRT6K
N1016HSRT6	N1016HSRT6K	80	125	22	1.1	1	113	42.5	50.0	4 300	5 100	11 000	21 900	86.5	118.5	114	1	1	31.6	N1016HSRT6	N1016HSRT6K
N1018HSRT6	N1018HSRT6K	90	140	24	1.5	1.1	127	53.0	64.5	5 450	6 550	9 700	19 500	98	132	129	1.5	1	41.1	N1018HSRT6	N1018HSRT6K
N1020HSRT6	N1020HSRT6K	100	150	24	1.5	1.1	137	56.0	70.5	5 700	7 200	9 000	18 000	108	142	139	1.5	1	45.1	N1020HSRT6	N1020HSRT6K

1) Minimum allowable value for corner radius dimension r or r₁.

ULTAGE Eco-friendly ultra high speed single-row cylindrical roller bearings
Air-oil lubrication only

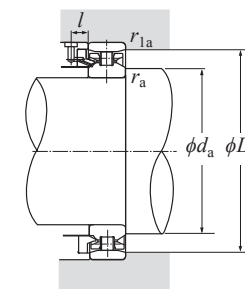
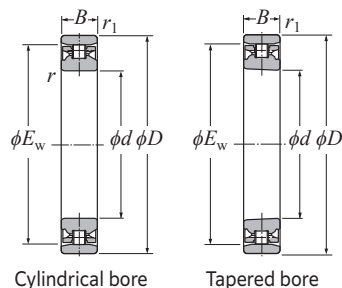

Dynamic equivalent radial load
 $P_r = F_r$

Static equivalent radial load
 $P_{0r} = F_r$

d 55-100 mm

Part number		Boundary dimensions						Basic load ratings				Allowable speed min ⁻¹ oil lubrication	Abutment and fillet dimensions					Part number		
cylindrical bore	tapered bore	mm						dynamic kN	static	dynamic kgf	static		mm					cylindrical bore	tapered bore	
		d	D	B	r _{s min¹⁾}	r _{ls min¹⁾}	E _w	C _r	C _{0r}	C _r	C _{0r}	d _{a min}	D _{b max}	r _{as max}	r _{las max}	l ²⁾ min				
N1011HSLT6	N1011HSLT6K	55	90	18	1.1	1	81	26.7	28.7	2 730	2 930	30 900	61.5	83.5	82	1	1	8.5	N1011HSLT6	N1011HSLT6K
N1012HSLT6	N1012HSLT6K	60	95	18	1.1	1	86.1	26.4	28.9	2 700	2 950	28 900	66.5	88.5	87	1	1	8.5	N1012HSLT6	N1012HSLT6K
N1013HSLT6	N1013HSLT6K	65	100	18	1.1	1	91	28.1	32.0	2 860	3 250	27 200	71.5	93.5	92	1	1	8.5	N1013HSLT6	N1013HSLT6K
N1014HSLT6	N1014HSLT6K	70	110	20	1.1	1	100	32.5	37.5	3 300	3 850	24 700	76.5	103.5	101	1	1	10	N1014HSLT6	N1014HSLT6K
N1016HSLT6	N1016HSLT6K	80	125	22	1.1	1	113	42.5	50.0	4 300	5 100	21 900	86.5	118.5	114	1	1	10	N1016HSLT6	N1016HSLT6K
N1018HSLT6	N1018HSLT6K	90	140	24	1.5	1.1	127	53.0	64.5	5 450	6 550	19 500	98	132	129	1.5	1	10	N1018HSLT6	N1018HSLT6K
N1020HSLT6	N1020HSLT6K	100	150	24	1.5	1.1	137	56.0	70.5	5 700	7 200	18 000	108	142	139	1.5	1	10	N1020HSLT6	N1020HSLT6K

1) Minimum allowable value for corner radius dimension r or r₁.
2) For the details of spacer dimensions, please contact NTN Engineering.

10.12 Taper gauge and mounted internal clearance adjustment gauge for NTN precision cylindrical roller bearings

As the need increases for machine tools of higher speed and precision, a higher degree of precision is required of machine tool bearings. For a precision bearing to exhibit its full performance, it must be installed correctly. In particular, when a tapered bore bearing is used, the corresponding taper on the shaft must be finished to a high degree of precision. **NTN** recommends the ring gauge for the tapered

Dimension table for taper gauge

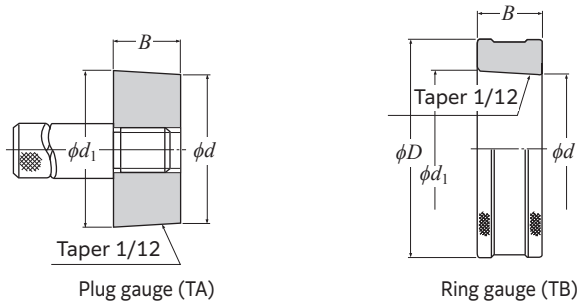

Part number		Applicable bearing		Boundary dimensions				Mass (approx.) kg	
				mm					
Plug gauge	Ring gauge			d	d ₁	D	B	TA type	TB type
TANN3006K	TBNN3006K	N1006HSK	NN3006K	30	31.583	70	19	0.2	0.5
TANN3007K	TBNN3007K	N1007HSK	NN3007K	35	36.667	75	20	0.3	0.6
TANN3008K	TBNN3008K	N1008HSK	NN3008K	40	41.750	80	21	0.3	0.7
TANN3009K	TBNN3009K	N1009HSK	NN3009K	45	46.917	85	23	0.4	0.7
TANN3010K	TBNN3010K	N1010HSK	NN3010K	50	51.917	90	23	0.5	0.8
TANN3011K	TBNN3011K	N1011HSK	NN3011K	55	57.167	95	26	0.7	0.9
TANN3012K	TBNN3012K	N1012HSK	NN3012K	60	62.167	100	26	0.8	1.0
TANN3013K	TBNN3013K	N1013HSK	NN3013K	65	67.167	105	26	0.9	1.1
TANN3014K	TBNN3014K	N1014HSK	NN3014K	70	72.500	110	30	1.3	1.3
TANN3015K	TBNN3015K	N1015HSK	NN3015K	75	77.500	115	30	1.4	1.4
TANN3016K	TBNN3016K	N1016HSK	NN3016K	80	82.833	125	34	1.7	1.9
TANN3017K	TBNN3017K	N1017HSK	NN3017K	85	87.833	130	34	1.9	2.0
TANN3018K	TBNN3018K	N1018HSK	NN3018K	90	93.083	140	37	2.4	2.6
TANN3019K	TBNN3019K	N1019HSK	NN3019K	95	98.083	145	37	2.6	2.7
TANN3020K	TBNN3020K	N1020HSK	NN3020K	100	103.083	150	37	2.8	2.8
TANN3021K	TBNN3021K	N1021HSK	NN3021K	105	108.417	160	41	3.5	3.6
TANN3022K	TBNN3022K	N1022HSK	NN3022K	110	113.750	165	45	4.0	4.1
TANN3024K	TBNN3024K	N1024HSK	NN3024K	120	123.833	170	46	4.7	4.1
TANN3026K	TBNN3026K	N1026HSK	NN3026K	130	134.333	180	52	6.4	4.8
TANN3028K	TBNN3028K	N1028HSK	NN3028K	140	144.417	190	53	7.4	5.2
TANN3030K	TBNN3030K	N1030HSK	NN3030K	150	154.667	210	56	8.4	7.2
TANN3032K	TBNN3032K	N1032HSK	NN3032K	160	165.000	220	60	10	8.1

shaft be finished to the same precision as for bearings. Note that the contact area between tapered faces should be 80 % or greater.

NTN also offers a plug gauge that permits verification of the precision of the ring gauge. Remember that the radial internal clearance of a cylindrical roller bearing needs to be correctly adjusted. Too large a radial clearance can diminish the precision of the main spindle, while too small a radial clearance can lead to abnormal heat generation and premature spalling of the bearing. To ensure adequate internal clearance, use a mounted internal clearance adjustment gauge.

Dimension table for mounted internal clearance adjustment gauge

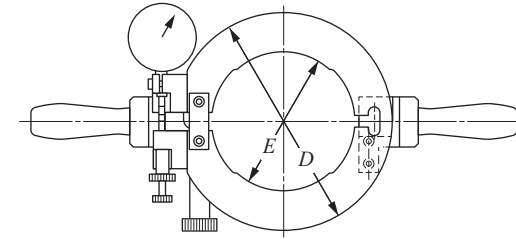

Part number		Applicable bearing		Boundary dimensions		
				mm		
				E	D	width B
SBNN3007-2	N1007HSK	NN3007K		55	101	23
SBNN3008-2	N1008HSK	NN3008K		61	107	23
SBNN3009-2	N1009HSK	NN3009K		67.5	114	23
SBNN3010-2	N1010HSK	NN3010K		72.5	120	23
SBNN3011-2	N1011HSK	NN3011K		81	131	25
SBNN3012-2	N1012HSK	NN3012K		86.1	138	25
SBNN3013-2	N1013HSK	NN3013K		91	145	25
SBNN3014-2	N1014HSK	NN3014K		100	156	28
SBNN3015-2	N1015HSK	NN3015K		105	161	28
SBNN3016-2	N1016HSK	NN3016K		113	175	30
SBNN3017-2	N1017HSK	NN3017K		118	185	30
SBNN3018-2	N1018HSK	NN3018K		127	195	33
SBNN3019-2	N1019HSK	NN3019K		132	204	33
SBNN3020-2	N1020HSK	NN3020K		137	210	33
SBNN3021-2	N1021HSK	NN3021K		146	220	36
SBNN3022-2	N1022HSK	NN3022K		155	235	40
SBNN3024-2	N1024HSK	NN3024K		165	250	40
SBNN3026-2	N1026HSK	NN3026K		182	275	45
SBNN3028-2	N1028HSK	NN3028K		192	285	45
SBNN3030-2	N1030HSK	NN3030K		206	305	50
SBNN3032-2	N1032HSK	NN3032K		219	320	50

Main Spindle Bearings

Main Spindle Bearings



Main Spindle Bearings

11. Angular Contact Ball Bearings for Axial Loads CONTENTS

11.1 Types and features	288
11.2 Standard cage types	289
11.3 Bearing designations	289
11.4 Accuracy of double-direction angular contact thrust ball bearings	290
11.5 Accuracy of duplex angular contact ball bearings for axial loads	291
11.6 Standard preload	292
11.7 Fits of angular contact ball bearings for axial loads	293
11.8 Recommended lubrication specifications	294
11.9 Angular contact ball bearings for axial loads HTA U type	295
Dimension Tables	
Double-direction angular contact thrust ball bearings	298
Angular contact ball bearings for axial loads	302



11. Angular Contact Ball Bearings for Axial Loads

11.1 Types and features

NTN provides a range of thrust bearings for the main spindles. This includes 5629 and 5620 types for high axial rigidity (contact angle 60°) and ULTAGE series HTA U (A) types high speed duplex angular contact ball bearings for axial loads with optimized

internal design (contact angle 40°, 30°). These bearings are used in conjunction with NN30, NN49, or NNU49 type double-row cylindrical roller bearings (matched bearings must have the same bore and outside diameter).

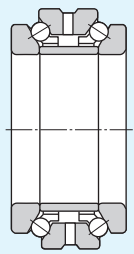
Table 11.1 Types of angular contact ball bearings for axial loads

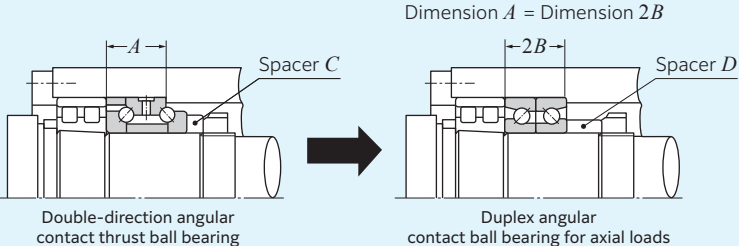
	Double-direction thrust type 5629 and 5620	ULTAGE series duplex type HTA0U (A) DB, HTA9U (A) DB
Cross section		
Contact angle	60°	40°, 30°
Cage type	High strength machined brass	Machined phenol resin, polyamide resin, high strength machined brass
Features	These bearings can withstand axial loads in both directions. Due to a larger contact angle, rigidity in axial directions is enhanced. The structure of these bearings is not suitable for grease-lubricated vertical shaft applications.	These duplex angular contact ball bearings have similar designs as the double-direction angular contact thrust ball bearings, but differ in terms on their inner ring widths (see the diagrams below). Since their contact angles are lower at 40° and 30°, the series boast high speed capability. However, their axial rigidity is less than double-direction angular contact thrust ball bearings with 60° contact angle.
Interchangeability	<p>A double-direction angular contact thrust ball bearing can be readily interchanged with a duplex angular contact ball bearing simply by replacing spacer C with spacer D; the dimensions of the shaft and housing remain unchanged.</p>  <p>Dimension $A = \text{Dimension } 2B$</p>	

11.2 Standard cage types

Table 11.2 Standard cage of angular contact ball bearing for axial loads

Bearing types	Machined phenol resin cage	High strength machined brass cage
5629 5620	—	562920 to 562964 562005 to 562064
HTA9U (A) HTA0U (A)	HTA920U to HTA938U ¹⁾ HTA010U to HTA038U	HTA940U to HTA964U HTA040U to HTA064U

1) Some varieties use polyamide resin cages, so please contact NTN Engineering.
Notes: Cage types may be subjected to change without notice. For details, contact NTN Engineering.

11.3 Bearing designations

562 0 20M / GN P4

- 562**: Bearing type
- 0**: Dimension series code
- 20**: Bore code (refer to the dimensions tables)
without M: Tapered shaft small side diameter type (Ex.: 562020→φ100 mm bore)
with M: Tapered shaft large side diameter type (Ex.: 562020→φ103 mm bore)
- M**: Internal clearance code
GN: Normal preload
GM: Medium preload
- P4**: Tolerance class code
P5: NTN Class 5
P4: NTN Class 4

5S- HTA 0 20 U A T2 DB / GN P4L

- 5S**: Material code
No code: Bearing steel
- HTA**: Bearing series: ULTAGE
- 0**: Dimension series code
- 20**: Nominal bore diameter (see the dimension tables)
- U**: Contact angle code
No code: 40°
A: 30°
- A**: Cage code
No code: Standard cage
T2: Polyamide resin cage
L1: High strength machined brass cage
- T2**: Duplex arrangement code
DB: back-to-back (double-row)
DTBT: tandem back-to-back (four-row)
- DB**: Internal clearance code
GN: Normal preload
GM: Medium preload
- GN**: Tolerance class code
P5: NTN Class 5
P4: NTN Class 4
L: Outer ring outside diameter tolerance for axial load

Main Spindle Bearings

Main Spindle Bearings

11.4 Accuracy of double-direction angular contact thrust ball bearings

Table 11.3 Inner rings

Unit: μm

Nominal bore diameter		Deviation of mean bore diameter in a single plane				Perpendicularity of inner ring face with respect to the bore		Axial runout		Width variation		Deviation of the bearing height	
d		Δ_{dmp}				S_d		S_{ia}		V_{Bs}		Δ_{Ts}	
over	incl.	Class 5		Class 4 ¹⁾		Class 5	Class 4	Class 5	Class 4	Class 5	Class 4	Class 5	Class 4
		high	low	high	low	max	max	max	max	max	max	high	low
18	30	0	-6	0	-5	8	4	5	3	5	2.5	0	-300
30	50	0	-8	0	-6	8	4	5	3	5	3	0	-400
50	80	0	-9	0	-7	8	5	6	5	6	4	0	-500
80	120	0	-10	0	-8	9	5	6	5	7	4	0	-600
120	180	0	-13	0	-10	10	6	8	6	8	5	0	-700
180	250	0	-15	0	-12	11	7	8	6	10	6	0	-800
250	315	0	-18	0	-15	13	8	10	8	13	7	0	-900
315	400	0	-23	0	-18	15	9	13	10	15	9	0	-1000

1) The dimensional difference Δ_{ds} of the measured bore diameter applied to Class 4 is the same as the tolerance of dimensional difference Δ_{dmp} of the mean bore diameter within a plane. The applied to diameter series 0.

Table 11.4 Outer rings

Unit: μm

Nominal outside diameter		Deviation of mean outside diameter in a single plane		Perpendicularity of outer ring outside surface with respect to the face		Axial runout		Width variation	
D		Δ_{Dmp}		S_D		S_{ea}		V_{Cs}	
over	incl.	Class 5	Class 4 ²⁾	Class 5	Class 4	Class 5	Class 4	Class 5	Class 4
		high	low	max	max	max	max	max	max
30	50	-30	-40	8	4	Depends on tolerance of S_{ia} in relation to d of the same bearing	5	2.5	
50	80	-40	-50	8	4		6	3	
80	120	-50	-60	9	5		8	4	
120	150	-60	-75	10	5	8	5		
150	180	-60	-75	10	5	8	5		
180	250	-75	-90	11	7	10	7		
250	315	-90	-105	13	8	11	7		
315	400	-110	-125	13	10	13	8		
400	500	-120	-140	15	13	15	10		

2) The dimensional difference Δ_{Ds} of the measured outside diameter applied to Class 4 is the same as the tolerance of dimensional difference Δ_{Dmp} of the mean outside diameter within a plane. The applied to diameter series 0. Note: This standard is the **NTN** standard.

11.5 Accuracy of duplex angular contact ball bearings for axial loads

Table 11.5 Inner rings

Unit: μm

Nominal bore diameter		Deviation of mean bore diameter in a single plane				Variation of bore diameter in a single plane				Variation of mean bore diameter		Perpendicularity of inner ring face with respect to the bore		Axial runout			
d		Δ_{dmp}				V_{dsp}				V_{dmp}		S_d		S_{ia}			
over	incl.	Class 5		Class 4 ¹⁾		Diameter series 9		Diameter series 0		Class 5	Class 4	Class 5	Class 4	Class 5	Class 4	Class 5L	Class 4L
		high	low	high	low	max	max	max	max	max	max	max	max	max	max	max	max
18	30	0	-6	0	-5	6	5	5	4	3	2.5	8	4	5	3		
30	50	0	-8	0	-6	8	6	6	5	4	3	8	4	5	3		
50	80	0	-9	0	-7	9	7	7	5	5	3.5	8	5	6	5		
80	120	0	-10	0	-8	10	8	8	6	5	4	9	5	6	5		
120	150	0	-13	0	-10	13	10	10	8	7	5	10	6	8	6		
150	180	0	-13	0	-10	13	10	10	8	7	5	10	6	8	6		
180	250	0	-15	0	-12	15	12	12	9	8	6	11	7	8	6		
250	315	0	-18	0	-14	18	14	14	11	9	8	13	8	10	8		
315	400	0	-23	0	-16	23	17	18	12	12	9	15	10	13	10		

Unit: μm

1) The dimensional difference Δ_{ds} of the measured bore diameter applied to Class 4 is the same as the tolerance of dimensional difference Δ_{dmp} of the mean bore diameter within a plane. The applied to diameter series 0.

Overall width variation of assembled bearing		Width variation		Nominal bore diameter	
Δ_{Bs}		V_{Bs}		d	
Class 5	Class 4	Class 5	Class 4	over	incl.
high	low	max	max		
0	-240	5	2.5	18	30
0	-240	5	3	30	50
0	-300	6	4	50	80
0	-400	7	4	80	120
0	-500	8	5	120	150
0	-500	8	5	150	180
0	-600	10	6	180	250
0	-700	13	8	250	315
0	-800	15	10	315	400

Table 11.6 Outer rings

Unit: μm

Nominal outside diameter		Deviation of mean outside diameter in a single plane				Axial runout		Overall width variation of assembled bearing		Width variation		
D		Δ_{Dmp}				S_{ea}		Δ_{Cs}		V_{Cs}		
over	incl.	Class 5L	Class 4L	Class 5		Class 5	Class 4 ²⁾	Class 5	Class 4	Class 5	Class 4	
		high	low	high	low	high	low	max	max	max	max	
30	50	-25	-36	0	-7	0	-6	8	5	Depends on tolerance of Δ_{Bs} in relation to d of the same bearing	5	2.5
50	80	-30	-43	0	-9	0	-7	10	5		6	3
80	120	-36	-51	0	-10	0	-8	11	6		8	4
120	150	-43	-61	0	-11	0	-9	13	7	8	5	
150	180	-43	-61	0	-13	0	-10	14	8	8	5	
180	250	-50	-70	0	-15	0	-11	15	10	10	7	
250	315	-56	-79	0	-18	0	-13	18	10	11	7	
315	400	-62	-87	0	-20	0	-15	20	13	13	8	
400	500	-68	-95	0	-23	-	-	23	15	15	10	

2) The dimensional difference Δ_{Ds} of the measured outside diameter applied to Class 4 is the same as the tolerance of dimensional difference Δ_{Dmp} of the mean outside diameter within a plane. The applied to diameter series 0. Note: This standard is the **NTN** standard.

Main Spindle Bearings

Main Spindle Bearings

11.6 Standard preload

The initial internal clearance or initial preload must be selected with consideration of the lubricating method, maximum speed, and required axial rigidity. Although usage with normal preload (GN) within the allowable speed range is possible for both grease

lubrication and air-oil lubrication, ask **NTN Engineering** to recommend the appropriate preload if axial rigidity is required and you want to inhibit temperature rise of the main spindle. The standard preloads are summarized in **Table 11.7**.

Table 11.7 Standard preload

Unit: N {kgf}

Bore number	5629		5620		HTA9UDB		HTA9UADB		HTA0UDB		HTA0UADB		Bore number
	Normal GN	Medium GM	Normal GN	Medium GM	Normal GN	Medium GM	Normal GN	Medium GM	Normal GN	Medium GM	Normal GN	Medium GM	
05			294 {30}	685 {70}									05
06													06
07			490 {50}	785 {80}									07
08													08
09													09
10											294 {30}	590 {60}	10
11			980 {100}	1 670 {170}					685 {70}	1 270 {130}	490 {50}	885 {90}	11
12													12
13													13
14													14
15									980 {100}	1 570 {160}	590 {60}	1 470 {150}	15
16			1 470 {150}	2 450 {250}						1 960 {200}			16
17													17
18											885 {90}	1 960 {200}	18
19									1 470 {150}	2 450 {250}			19
20					980 {100}	1 670 {170}	685 {70}	1 270 {130}					20
21	1 470 {150}	2 450 {250}									980 {100}	2 450 {250}	21
22									1 960 {200}	3 450 {350}			22
24			1 960 {200}	3 250 {330}			885 {90}	1 770 {180}					24
26					1 270 {130}	2 450 {250}	980 {100}	1 960 {200}					26
28	1 960 {200}	2 940 {300}							2 940 {300}	5 400 {550}	1 470 {150}	3 450 {350}	28
30													30
32					1 960 {200}	3 450 {350}	1 270 {130}	2 450 {250}					32
34									3 900 {400}	7 350 {750}	2 450 {250}	4 900 {500}	34
36													36
38	2 450 {250}	3 900 {400}	2 450 {250}	3 900 {400}	3 450 {350}	5 900 {600}	1 770 {180}	3 450 {350}	4 900 {500}	9 300 {950}			38
40											3 450 {350}	6 850 {700}	40
44	2 940 {300}	4 400 {450}			3 900 {400}	6 850 {700}			6 850 {700}	12 700 {1 300}	3 900 {400}	7 850 {800}	44
48			2 940 {300}	4 400 {450}									48
52					4 900 {500}	8 850 {900}			8 850 {900}	15 700 {1 600}			52
56	3 900 {400}	5 900 {600}											56
60			3 900 {400}	5 900 {600}	5 900 {600}	11 800 {1 200}			10 800 {1 100}	17 700 {1 800}	5 900 {600}	11 800 {1 200}	60
64	4 900 {500}	7 350 {750}											64

11.7 Fits of angular contact ball bearings for axial loads

Fits given in **Table 11.8** are recommended for angular contact ball bearings for axial loads. To maintain high accuracy, provision of interference between the shaft and the bore of inner ring is essential. The fit of the housing and bearing should be same as that for cylindrical roller bearings, since an angular contact ball bearing is normally used together with a cylindrical roller bearing.

■ Checking concentricity of outside diameter of outer ring after bearing

Controlling concentricity of outer ring assembly is necessary for reduction of axial runout of the main spindle. Measure and control the concentricity of outer ring shown in **Fig. 11.1** and "6. Handling of Bearings, 6.2 Mounting" in the Technical Data section.

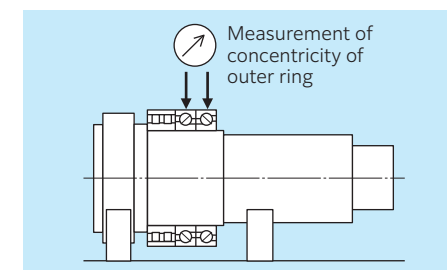

Fig. 11.1 Concentricity

Table 11.8 Shaft fits

Unit: μm

Nominal bore diameter d (mm)	Fits of inner ring to shaft	
	over	incl.
2.5	10	0-2T
10	18	0-2T
18	30	0-2.5T
30	50	0-3T
50	80	0-3.5T
80	120	0-4T
120	180	0-5T
180	250	0-6T

Note 1: Target the median value.
 2: For high speed applications where d_{m1} value exceeds 0.75×10^6 , the fit should be increased. For such an arrangement, consult **NTN Engineering**.
 T: Tight (Interference) fit

11.8 Recommended lubrication specifications

Angular contact ball bearings for axial loads are usually used with grease lubrication or air-oil lubrication. Recommended specifications of the lubrication methods are described below.

■ Grease lubrication

● Recommended brand of grease

Refer to "7. Lubrication of Bearings, 7.1 Grease lubrication" in the Technical Data section.

● Recommended grease filling amount

$d_{m,n}$ value $\leq 0.65 \times 10^6$

15 % of the capacity shown in the dimensions tables

$d_{m,n}$ value $> 0.65 \times 10^6$

12 % of the capacity shown in the dimensions tables

● Recommended grease filling method

Refer to "6. Handling of Bearings, 6.1 Cleaning and filling with grease" in the Technical Data section.

Notes: High-strength machined brass cages are used for 5629/5620 types. Thus, if they are used for grease-lubricated vertical shafts, the cage on one side may hang onto the rolling elements, possibly causing seizure. Use of the HTA U type with resin cages or oil lubrication (including feeding of lubricating oil) is recommended.

■ Air-oil lubrication

● Recommended location of nozzle

Refer to "7. Lubrication of Bearings 7.2 Recommended location of nozzle for air-oil lubrication" in the Technical Data section.

● Recommended specifications of nozzle

Nozzle bore diameter : From 1 to 1.5 mm
Number of nozzles: One nozzle for each bearing, depth of nozzle bore should be four to six times of nozzle bore diameter.

● Recommended specifications of air-oil

Oil type: Spindle oil
Viscosity grade: ISO VG from 10 to 32 (32 is preferable)

Table 11.9 Air and oil amount

Bearing types	$d_{m,n}$ value ($\times 10^6$) Over Incl.	Oil amount per shot mL	Lubrication intervals min	Oil consumption mL/h	Recommended air consumption NL/min ¹⁾
HTA9U (A)	— 1.0	0.03	8	0.23	20 to 40
HTA0U (A)	1.0 1.25		5	0.36	
SS-HTA0U (A)					

1) NL/min (Normal liter/minute) ... NL means the volume of air at 0 °C and 1 atmosphere.

11.9 **ULTAGE** Angular contact ball bearings for axial loads HTA U type

The HTA U type is an angular contact ball bearing for axial loads. It maintains rigidity and load bearing capacity, and features improved high speed performance.

■ Features

1. Optimized internal design to minimize the temperature rise especially at high speed range.
2. Improved polyamide resin cage pocket design where the ball contacts to have improved lubrication performance under grease or air-oil lubrication.

■ Permissible speed range

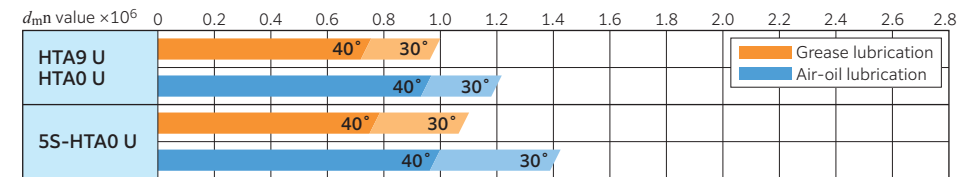

■ Bearings specification

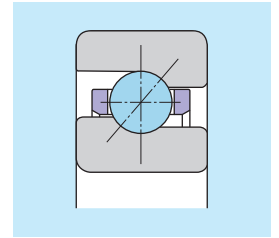

Fig. 11.2 HTA U type

Notes) Permissible speed of each bearing ($d_{m,n}$ value) varies depending on the specifications of the machine for which the bearing is used (motor drive system, cooling system, and construction around the bearing). Consider the optimal choice referring to the above guideline, and then, contact **NTN** Engineering for technical assistance.

■ Data/Axial rigidity

Minimizes drops in axial rigidity while supporting faster speeds (see Fig. 11.3).

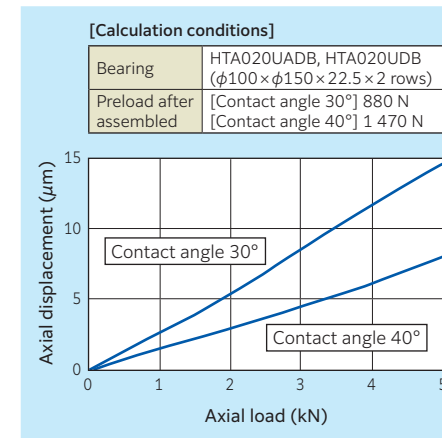

Fig. 11.3 Axial rigidity diagram

■ Data/Allowable axial load

A contact angle of 30° has a larger allowable axial load, compared to a contact angle of 40° (see Fig. 11.4).

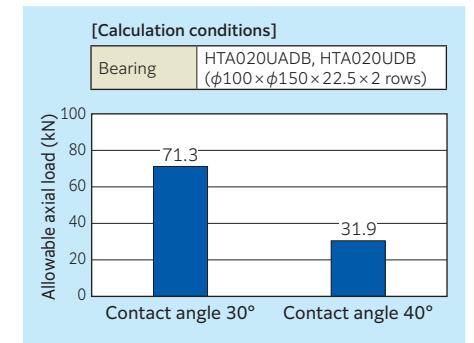

Fig. 11.4 Comparison of allowable axial load

Data/Operation test

d_{mn} value of 1.0×10^6 under grease lubrication and 1.25×10^6 under air-oil lubrication are realized by the optimized internal design (Both specification: steel ball, contact angle 30°) (see Fig. 11.5, Fig. 11.6).

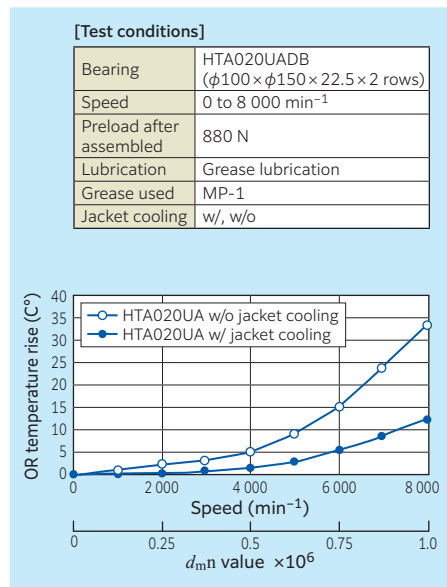

Fig. 11.5 Operation test results (contact angle 30° , grease lubrication)

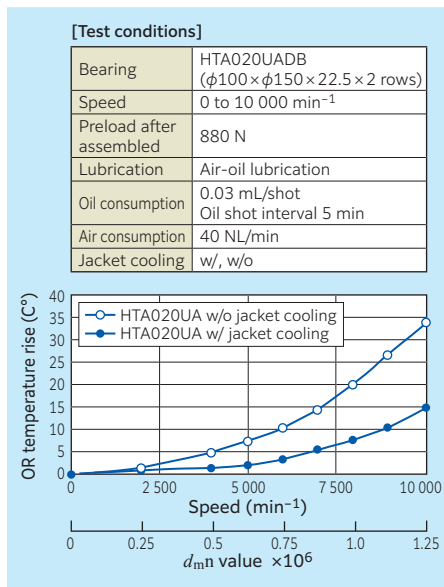

Fig. 11.6 Operation test results (contact angle 30° , air-oil lubrication)

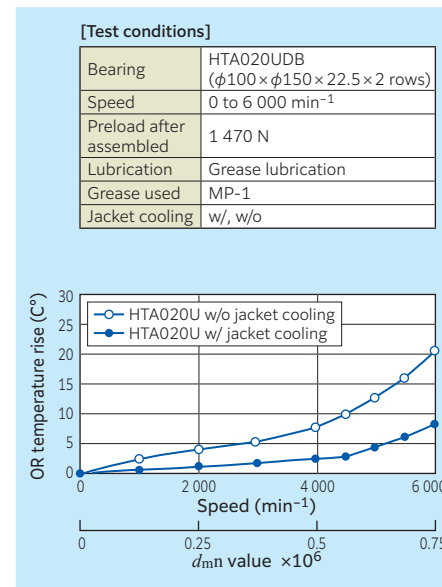

Fig. 11.7 Operation test results (contact angle 40° , grease lubrication)

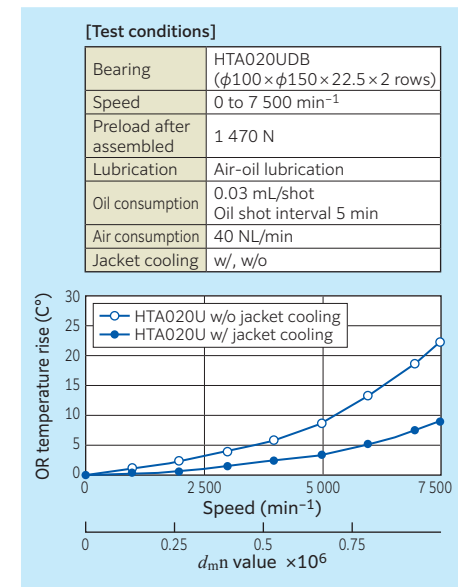
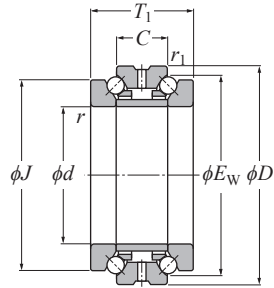

Fig. 11.8 Operation test results (contact angle 40° , air-oil lubrication)

Angular Contact Ball Bearings for Axial Loads Dimension Tables



Double-direction angular contact thrust ball bearings 5629 type



Angular Contact Ball Bearings for Axial Loads Dimension Tables

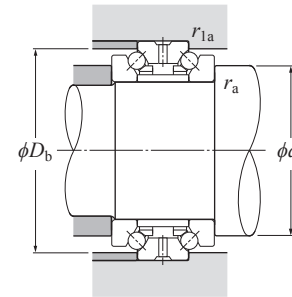

Dynamic equivalent axial load
 $P_a = F_a$

Static equivalent axial load
 $P_{0a} = F_a$

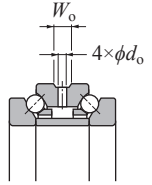

Contact angle 60° d 100–320 mm

Part number		Boundary dimensions								Basic load ratings				Allowable speed		Mass (approx.)		Reference dimensions		Abutment and fillet dimensions				Part number	
small size	large size	d		mm		$r_{s \min}^{(1)}$		$r_{1s \min}^{(1)}$		dynamic kN	static kgf	dynamic	static	grease lubrication	oil lubrication	small size	large size	J	$E_w^{(2)}$	d_a min	D_b max	r_{as} max	r_{1as} max	small size	large size
562920	562920M	100	104	140	48	24	1.1	0.6	58.0	179	5 900	18 200	3 200	4 200	2.04	1.8	126	129	114	134.5	1	0.6	562920	562920M	
562921	562921M	105	109	145	48	24	1.1	0.6	59.5	188	6 050	19 200	3 000	4 100	2.12	1.87	131	134	119	139.5	1	0.6	562921	562921M	
562922	562922M	110	114	150	48	24	1.1	0.6	59.5	193	6 100	19 700	2 900	3 900	2.21	1.95	136	139	124	144.5	1	0.6	562922	562922M	
562924	562924M	120	124	165	54	27	1.1	0.6	72.0	242	7 350	24 700	2 600	3 500	3.06	2.75	150	154.5	138	159.5	1	0.6	562924	562924M	
562926	562926M	130	134	180	60	30	1.5	1	83.0	284	8 450	28 900	2 400	3 200	4.11	3.7	163	168	150	173.5	1.5	1	562926	562926M	
562928	562928M	140	144	190	60	30	1.5	1	84.0	297	8 600	30 500	2 300	3 100	4.38	3.94	173	178	160	183.5	1.5	1	562928	562928M	
562930	562930M	150	155	210	72	36	2	1	118	410	12 100	41 500	2 100	2 800	6.88	6.2	190	196.5	174	202	2	1	562930	562930M	
562932	562932M	160	165	220	72	36	2	1	121	430	12 300	44 000	2 000	2 600	7.26	6.53	200	206.5	184	212	2	1	562932	562932M	
562934	562934M	170	175	230	72	36	2	1	123	450	12 500	46 000	1 900	2 500	7.64	6.88	210	216.5	194	222	2	1	562934	562934M	
562936	562936M	180	186	250	84	42	2	1	173	605	17 600	62 000	1 700	2 300	11.2	10	227	234	207	242	2	1	562936	562936M	
562938	562938M	190	196	260	84	42	2	1	174	625	17 700	63 500	1 700	2 200	11.7	10.5	237	244	217	252	2	1	562938	562938M	
562940	562940M	200	207	280	96	48	2.1	1.1	205	735	20 900	75 000	1 600	2 100	16.3	14.7	252	261	231	270	2	1	562940	562940M	
562944	562944M	220	227	300	96	48	2.1	1.1	211	795	21 500	81 000	1 400	1 900	17.7	16	272	281	251	290	2	1	562944	562944M	
562948	562948M	240	247	320	96	48	2.1	1.1	217	850	22 100	87 000	1 300	1 800	19	17	292	301	271	310	2	1	562948	562948M	
562952	562952M	260	269	360	120	60	2.1	1.1	289	1 130	29 400	116 000	1 200	1 600	32.9	29.6	328	336	299	350	2	1	562952	562952M	
562956	562956M	280	289	380	120	60	2.1	1.1	293	1 190	29 900	121 000	1 100	1 500	35	31.5	348	356	319	370	2	1	562956	562956M	
562960	562960M	300	310	420	144	72	3	1.1	375	1 510	38 000	154 000	1 000	1 400	55	49.5	384	391	349	410	2.5	1	562960	562960M	
562964	562964M	320	330	440	144	72	3	1.1	380	1 580	38 500	161 000	1 000	1 300	58.1	52.3	404	411	369	430	2.5	1	562964	562964M	

Dimensions of oil hole and oil groove unit: mm

Nominal outside diameter D		Oil groove width W_o	Oil hole diameter d_o
over	incl.		
140	190	8	4
190	260	12	6
260	320	14	6
320	380	16	8
380	440	22	12

1) Minimum allowable value for corner radius dimension r or r_1 .
2) Maximum circumscribed circle diameter of balls.

Main Spindle Bearings

Main Spindle Bearings

Angular Contact Ball Bearings for Axial Loads Dimension Tables

Double-direction angular contact thrust ball bearings 5620 type

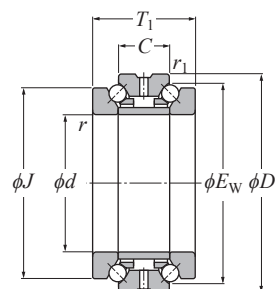

Contact angle 60° d 25-320 mm

Part number		Boundary dimensions								Basic load ratings				Allowable speed		Mass (approx.)		Reference dimensions		Abutment and fillet dimensions				Part number	
small size	large size	d		D	T ₁	C	r		C _a	C _{0a}	C _a	C _{0a}	grease lubrication	oil lubrication	small size	large size	J	E _w ²⁾	d _a min	D _b max	r _{as} max	r _{1as} max	small size	large size	
		small size	large size				r _s min ¹⁾	r _s min ¹⁾																	kN
562005	562005M	25	27	47	28	14	0.6	0.3	14.6	28.3	1 490	2 890	10 400	14 000	0.197	0.177	40	41.3	33	44	0.6	0.3	562005	562005M	
562006	562006M	30	32	55	32	16	1	0.6	15.5	32.5	1 580	3 350	8 700	11 700	0.301	0.28	47	48.5	40	50.5	1	0.6	562006	562006M	
562007	562007M	35	37	62	34	17	1	0.6	21.8	48.5	2 230	4 950	7 700	10 300	0.394	0.35	53	55	45.5	57.5	1	0.6	562007	562007M	
562008	562008M	40	42	68	36	18	1	0.6	26.4	58.5	2 690	5 950	7 000	9 400	0.482	0.44	58.5	61	50	63.5	1	0.6	562008	562008M	
562009	562009M	45	47	75	38	19	1	0.6	28.8	69.0	2 930	7 000	6 200	8 300	0.605	0.54	65	67.5	56.5	70.5	1	0.6	562009	562009M	
562010	562010M	50	52	80	38	19	1	0.6	29.6	74.0	3 000	7 550	5 700	7 700	0.638	0.59	70	72.5	61.5	75.5	1	0.6	562010	562010M	
562011	562011M	55	57	90	44	22	1.1	0.6	41.0	99.0	4 200	10 100	5 200	7 000	0.988	0.9	78	81	67.5	84	1	0.6	562011	562011M	
562012	562012M	60	62	95	44	22	1.1	0.6	41.5	103	4 250	10 500	4 900	6 500	1.06	0.96	83	86.1	72.5	89	1	0.6	562012	562012M	
562013	562013M	65	67	100	44	22	1.1	0.6	43.0	111	4 400	11 300	4 600	6 100	1.08	1	88	91	77.5	94	1	0.6	562013	562013M	
562014	562014M	70	73	110	48	24	1.1	0.6	52.5	140	5 350	14 300	4 200	5 600	1.53	1.4	97	100	85	104	1	0.6	562014	562014M	
562015	562015M	75	78	115	48	24	1.1	0.6	54.5	150	5 550	15 300	3 900	5 300	1.61	1.5	102	105	90	109	1	0.6	562015	562015M	
562016	562016M	80	83	125	54	27	1.1	0.6	63.5	178	6 500	18 200	3 700	4 900	2.2	2	110	113	96.5	119	1	0.6	562016	562016M	
562017	562017M	85	88	130	54	27	1.1	0.6	64.5	184	6 550	18 800	3 500	4 700	2.31	2.1	115	118	102	124	1	0.6	562017	562017M	
562018	562018M	90	93	140	60	30	1.5	1	74.5	216	7 600	22 000	3 300	4 400	3.05	2.7	123	127	109	133.5	1.5	1	562018	562018M	
562019	562019M	95	98	145	60	30	1.5	1	75.0	223	7 650	22 700	3 100	4 200	3.18	2.9	128	132	114	138.5	1.5	1	562019	562019M	
562020	562020M	100	103	150	60	30	1.5	1	76.0	229	7 750	23 400	3 000	4 000	3.32	3	133	137	119	143.5	1.5	1	562020	562020M	
562021	562021M	105	109	160	66	33	2	1	87.0	266	8 900	27 100	2 800	3 800	4.19	3.7	142	146	127	152	2	1	562021	562021M	
562022	562022M	110	114	170	72	36	2	1	106	315	10 800	32 500	2 700	3 600	5.35	4.9	150	155	133	162	2	1	562022	562022M	
562024	562024M	120	124	180	72	36	2	1	109	335	11 100	34 500	2 500	3 300	5.73	5.2	160	165	143	172	2	1	562024	562024M	
562026	562026M	130	135	200	84	42	2	1	154	460	15 700	47 000	2 300	3 100	8.58	7.6	177	182	155	192	2	1	562026	562026M	
562028	562028M	140	144	210	84	42	2	1	159	495	16 200	50 500	2 200	2 900	9.1	8.1	187	192	165	202	2	1	562028	562028M	
562030	562030M	150	155	225	90	45	2.1	1.1	163	525	16 600	53 500	2 000	2 700	11.2	10	200	206	178	215	2	1	562030	562030M	
562032	562032M	160	165	240	96	48	2.1	1.1	191	620	19 500	63 000	1 900	2 500	13.6	11.9	212	219	189	230	2	1	562032	562032M	
562034	562034M	170	175	260	108	54	2.1	1.1	224	735	22 900	75 000	1 800	2 400	18.5	16.5	230	236	203	250	2	1	562034	562034M	
562036	562036M	180	186	280	120	60	2.1	1.1	259	865	26 400	88 000	1 600	2 200	24.7	21.8	248	255	219	270	2	1	562036	562036M	
562038	562038M	190	196	290	120	60	2.1	1.1	262	890	26 700	91 000	1 600	2 100	25.5	23	258	265	229	280	2	1	562038	562038M	
562040	562040M	200	207	310	132	66	2.1	1.1	300	1 030	30 500	105 000	1 500	2 000	32.7	29.7	274	282	243	300	2	1	562040	562040M	
562044	562044M	220	227	340	144	72	3	1.1	370	1 270	37 500	129 000	1 300	1 800	42.8	38.5	304	310	267	330	2.5	1	562044	562044M	
562048	562048M	240	247	360	144	72	3	1.1	380	1 350	39 000	138 000	1 300	1 700	45.8	41.2	322	330	287	350	2.5	1	562048	562048M	
562052	562052M	260	269	400	164	82	4	1.5	450	1 710	46 000	174 000	1 100	1 500	67	60.3	354	364	315	388	3	1.5	562052	562052M	
562056	562056M	280	289	420	164	82	4	1.5	465	1 810	47 000	185 000	1 100	1 500	71.1	64	374	384	335	408	3	1.5	562056	562056M	
562060	562060M	300	310	460	190	95	4	1.5	530	2 170	54 000	222 000	1 000	1 300	102	91.8	406	418	364	448	3	1.5	562060	562060M	
562064	562064M	320	330	480	190	95	4	1.5	530	2 240	54 500	228 000	1 000	1 300	108	97.2	426	438	384	468	3	1.5	562964	562964M	

1) Minimum allowable value for corner radius dimension r or r₁.
2) Maximum circumscribed circle diameter of balls.

Angular Contact Ball Bearings for Axial Loads Dimension Tables

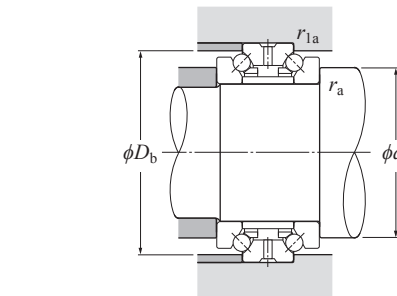

Dynamic equivalent axial load
 $P_a = F_a$

Static equivalent axial load
 $P_{0a} = F_a$

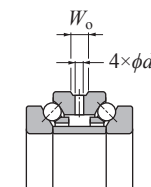

Dimensions of oil hole and oil groove unit: mm

Nominal outside diameter D	Oil groove width W _o	Oil hole diameter d _o
50	4.5	2
50	80	6
80	150	8
150	210	12
210	260	14
260	320	16
320	480	22
480	630	28
630	800	36
800	1000	46
1000	1300	60
1300	1700	80
1700	2200	105
2200	2900	140
2900	3800	180
3800	5000	240

Angular Contact Ball Bearings for Axial Loads

ULTAGE Angular contact ball bearings for axial loads (steel ball spec.)
HTA9UA type

Dimension Tables

NTN

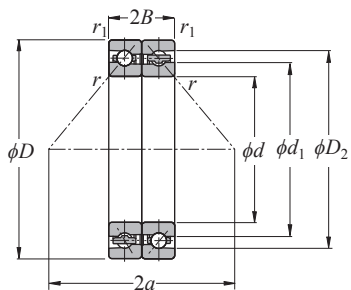

Angular Contact Ball Bearings for Axial Loads

Dynamic equivalent axial load
 $P_a = F_a$

Static equivalent axial load
 $P_{0a} = F_a$

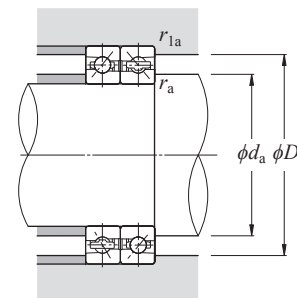

Contact angle 30° d 100–320 mm

Part number	Boundary dimensions					Basic load ratings				Allowable axial load		Allowable speed		Load center mm 2a	Internal free space cm ³ Two row (approx.)	Mass kg Two row (approx.)	Reference dimensions		Abutment and fillet dimensions				Part number	
	mm					dynamic kN	static	dynamic kgf	static	kN	kgf	min ⁻¹	mm				mm	mm	mm	mm	mm	mm		mm
	d	D	2B	r _{s min} ¹⁾	r _{1s min} ¹⁾	C _a	C _{0a}	C _a	C _{0a}	(static)	(static)	grease lubrication	oil lubrication				d ₁	D ₂	d _{a min}	D _{b max}	r _{as max}	r _{1as max}		
HTA920UADB	100	140	36	1.1	0.6	44.0	109	4 500	11 100	66.0	6 750	8 300	10 400	87.6	24	0.81	115.3	129.1	110	134	1	0.6	HTA920UADB	
HTA921UADB	105	145	36	1.1	0.6	45.5	115	4 650	11 700	70.0	7 150	8 000	10 000	90.5	24	0.85	120.3	134.1	115	139	1	0.6	HTA921UADB	
HTA922UADB	110	150	36	1.1	0.6	46.0	118	4 650	12 000	72.0	7 350	7 700	9 600	93.4	26	0.88	125.3	139.1	120	144	1	0.6	HTA922UADB	
HTA924UADB	120	165	40.5	1.1	0.6	53.5	140	5 450	14 300	87.5	8 900	7 000	8 800	102.9	36	1.23	137.4	152.4	130	159	1	0.6	HTA924UADB	
HTA926UADB	130	180	45	1.5	1	64.0	173	6 500	17 600	103	10 500	6 500	8 100	112.4	50	1.65	149.4	165.8	142	172.5	1.5	1	HTA926UADB	
HTA928UADB	140	190	45	1.5	1	64.0	177	6 500	18 000	106	10 800	6 100	7 600	118.1	53	1.75	159.4	175.8	152	182.5	1.5	1	HTA928UADB	
HTA930UADB	150	210	54	2	1	89.5	243	9 100	24 800	143	14 600	5 600	6 900	131.4	85	2.74	173.1	193.3	164	202.5	2	1	HTA930UADB	
HTA932UADB	160	220	54	2	1	91.5	256	9 300	26 100	151	15 400	5 300	6 600	137.1	90	2.89	183.1	203.3	174	212.5	2	1	HTA932UADB	
HTA934UADB	170	230	54	2	1	93.0	268	9 500	27 300	159	16 200	5 000	6 300	142.9	94	3.05	193.1	213.2	184	222.5	2	1	HTA934UADB	
HTA936UADB	180	250	63	2	1	140	400	14 300	41 000	239	24 400	4 700	5 800	156.2	138	4.78	206.4	231.5	194	242.5	2	1	HTA936UADB	
HTA938UADB	190	260	63	2	1	143	420	14 600	43 000	252	25 700	4 400	5 600	162.0	144	5.00	216.4	241.5	204	252.5	2	1	HTA938UADB	
HTA940UADB	200	280	72	2.1	1.1	169	500	17 200	51 000	305	31 000	4 200	5 200	175.2	197	7.00	230.6	258.2	217	270	2	1	HTA940UADB	
HTA944UADB	220	300	72	2.1	1.1	173	535	17 700	54 500	330	33 500	3 800	4 800	186.7	213	7.60	250.6	277.9	237	290	2	1	HTA944UADB	
HTA948UADB	240	320	72	2.1	1.1	178	570	18 100	58 000	350	35 500	3 600	4 500	198.3	229	8.15	270.6	297.9	257	310	2	1	HTA948UADB	
HTA952UADB	260	360	90	2.1	1.1	234	745	23 800	76 000	460	47 000	3 200	4 000	224.7	378	14.3	298.9	331.6	277	350	2	1	HTA952UADB	
HTA956UADB	280	380	90	2.1	1.1	241	795	24 500	81 000	490	50 000	3 000	3 800	236.3	403	15.2	318.9	351.4	297	370	2	1	HTA956UADB	
HTA960UADB	300	420	108	3	1.1	305	1 020	31 500	104 000	610	62 000	2 800	3 500	262.7	675	23.5	347.1	385.2	320	410	2.5	1	HTA960UADB	
HTA964UADB	320	440	108	3	1.1	310	1 060	32 000	108 000	635	65 000	2 600	3 300	274.2	715	24.8	367.1	405.0	340	430	2.5	1	HTA964UADB	

1) Minimum allowable value for corner radius dimension r or r₁.

Main Spindle Bearings

Main Spindle Bearings

Angular Contact Ball Bearings for Axial Loads

ULTAGE Angular contact ball bearings for axial loads (steel ball spec.)
HTA9U type

Dimension Tables

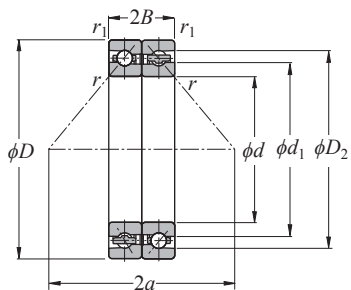

Angular Contact Ball Bearings for Axial Loads

Dynamic equivalent axial load $P_a = F_a$
Static equivalent axial load $P_{0a} = F_a$

Dimension Tables

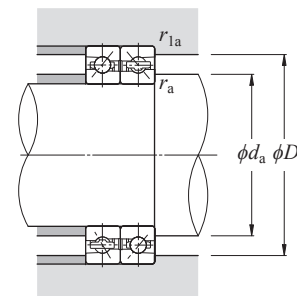

Contact angle 40° d 100–320 mm

Part number	Boundary dimensions					Basic load ratings				Allowable axial load		Allowable speed		Load center mm	Internal free space cm ³ Two row (approx.)	Mass kg Two row (approx.)	Reference dimensions		Abutment and fillet dimensions				Part number	
	mm					dynamic kN	static	dynamic	static	kN	kgf	min ⁻¹	mm				mm	mm	mm	mm	mm	mm		mm
	d	D	$2B$	$r_s \text{ min}^{-1}$	$r_{1s} \text{ min}^{-1}$	C_a	C_{0a}	C_a	C_{0a}	(static)		grease lubrication	oil lubrication				$2a$	d_1	D_2	$d_a \text{ min}$	$D_b \text{ max}$	$r_{as} \text{ max}$		$r_{1as} \text{ max}$
HTA920UDB	100	140	36	1.1	0.6	52.5	121	5 350	12 300	29.3	2 990	6 300	7 900	119.1	24	0.81	115.3	129.0	110	134	1	0.6	HTA920UDB	
HTA921UDB	105	145	36	1.1	0.6	53.5	128	5 500	13 000	31.0	3 150	6 000	7 600	123.3	24	0.85	120.3	134.0	115	139	1	0.6	HTA921UDB	
HTA922UDB	110	150	36	1.1	0.6	54.0	131	5 500	13 400	32.0	3 250	5 800	7 300	127.5	26	0.88	125.3	139.0	120	144	1	0.6	HTA922UDB	
HTA924UDB	120	165	40.5	1.1	0.6	63.0	156	6 450	15 900	39.0	4 000	5 300	6 700	140.3	36	1.23	137.4	152.3	130	159	1	0.6	HTA924UDB	
HTA926UDB	130	180	45	1.5	1	75.5	193	7 700	19 600	44.5	4 550	4 800	6 100	153.1	50	1.65	149.4	165.7	142	172.5	1.5	1	HTA926UDB	
HTA928UDB	140	190	45	1.5	1	75.5	197	7 700	20 100	46.0	4 700	4 500	5 800	161.5	53	1.75	159.4	175.7	152	182.5	1.5	1	HTA928UDB	
HTA930UDB	150	210	54	2	1	106	270	10 800	27 600	62.5	6 350	4 200	5 300	178.7	85	2.74	173.1	193.2	164	202.5	2	1	HTA930UDB	
HTA932UDB	160	220	54	2	1	108	284	11 000	29 000	65.5	6 700	3 900	5 000	187.1	90	2.89	183.1	203.2	174	212.5	2	1	HTA932UDB	
HTA934UDB	170	230	54	2	1	110	298	11 200	30 500	69.0	7 050	3 800	4 800	195.5	94	3.05	193.1	213.3	184	222.5	2	1	HTA934UDB	
HTA936UDB	180	250	63	2	1	166	445	16 900	45 500	104	10 600	3 500	4 400	212.7	138	4.78	206.4	231.5	194	242.5	2	1	HTA936UDB	
HTA938UDB	190	260	63	2	1	170	470	17 300	48 000	110	11 200	3 300	4 200	221.1	144	5.00	216.4	241.6	204	252.5	2	1	HTA938UDB	
HTA940UDB	200	280	72	2.1	1.1	200	555	20 400	56 500	134	13 700	3 100	4 000	238.3	197	7.00	230.6	258.2	217	270	2	1	HTA940UDB	
HTA944UDB	220	300	72	2.1	1.1	205	595	20 900	60 500	145	14 800	2 900	3 700	255.1	213	7.60	250.6	278.2	237	290	2	1	HTA944UDB	
HTA948UDB	240	320	72	2.1	1.1	210	635	21 500	64 500	155	15 800	2 700	3 400	271.8	229	8.15	270.6	298.0	257	310	2	1	HTA948UDB	
HTA952UDB	260	360	90	2.1	1.1	276	830	28 200	84 500	203	20 700	2 400	3 100	306.2	378	14.3	298.9	331.6	277	350	2	1	HTA952UDB	
HTA956UDB	280	380	90	2.1	1.1	284	885	29 000	90 500	218	22 200	2 300	2 900	323.0	403	15.2	318.9	351.6	297	370	2	1	HTA956UDB	
HTA960UDB	300	420	108	3	1.1	365	1 130	37 000	115 000	266	27 100	2 100	2 600	357.3	675	23.5	347.1	385.0	320	410	2.5	1	HTA960UDB	
HTA964UDB	320	440	108	3	1.1	370	1 180	37 500	120 000	279	28 400	2 000	2 500	374.1	715	24.8	367.1	405.2	340	430	2.5	1	HTA964UDB	

1) Minimum allowable value for corner radius dimension r or r_1 .

Angular Contact Ball Bearings for Axial Loads

Dimension Tables



ULTAGE Angular contact ball bearings for axial loads (steel ball spec.)
HTA0UA type

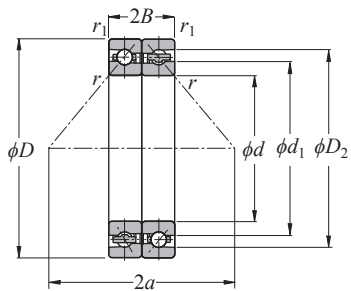

Angular Contact Ball Bearings for Axial Loads

Dimension Tables

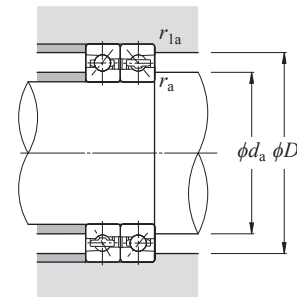

Dynamic equivalent axial load
 $P_a = F_a$

Static equivalent axial load
 $P_{0a} = F_a$

Contact angle 30° d 50–320 mm

Part number	Boundary dimensions						Basic load ratings				Allowable axial load		Allowable speed		Load center mm	Internal free space cm ³	Mass kg	Reference dimensions		Abutment and fillet dimensions				Part number
	mm						dynamic kN	static	dynamic kgf	static	kN	kgf	grease min ⁻¹	oil lubrication				mm	Two row (approx.)	Two row (approx.)	mm	mm	mm	
	d	D	2B	r _s min ¹⁾	r _{1s} min ¹⁾	r ₁	C _a	C _{0a}	C _a	C _{0a}	(static)	(static)	2a	2a	d ₁	D ₂	d _a min	D _b max	r _{as} max	r _{1as} max				
HTA010UADB	50	80	28.5	1	0.6	27.5	48.5	2 810	4 950	23.2	2 370	15 400	19 200	52.1	9	0.24	60.7	73.2	57.5	74.0	1	0.6	HTA010UADB	
HTA011UADB	55	90	33	1.1	0.6	29.8	57.5	3 050	5 850	27.7	2 820	13 800	17 200	58.6	13	0.39	68.2	80.8	65.0	84.0	1	0.6	HTA011UADB	
HTA012UADB	60	95	33	1.1	0.6	31.0	63.0	3 200	6 400	30.5	3 100	12 900	16 100	61.5	13	0.41	73.2	85.8	70.0	89.0	1	0.6	HTA012UADB	
HTA013UADB	65	100	33	1.1	0.6	31.5	65.0	3 250	6 650	32.0	3 250	12 100	15 200	64.4	14	0.44	78.2	90.8	75.0	94.0	1	0.6	HTA013UADB	
HTA014UADB	70	110	36	1.1	0.6	38.5	82.0	3 950	8 350	40.0	4 100	11 100	13 900	70.3	18	0.61	85.3	99.1	80.0	104	1	0.6	HTA014UADB	
HTA015UADB	75	115	36	1.1	0.6	41.0	91.5	4 200	9 300	45.5	4 650	10 500	13 200	73.2	19	0.65	90.3	104.1	85.0	109	1	0.6	HTA015UADB	
HTA016UADB	80	125	40.5	1.1	0.6	47.0	105	4 800	10 700	52.0	5 300	9 800	12 200	79.8	26	0.88	97.4	112.5	90.0	119	1	0.6	HTA016UADB	
HTA017UADB	85	130	40.5	1.1	0.6	48.0	108	4 850	11 100	54.5	5 550	9 300	11 600	82.7	28	0.93	102.4	117.5	95.0	124	1	0.6	HTA017UADB	
HTA018UADB	90	140	45	1.5	1	55.5	127	5 650	13 000	63.5	6 500	8 700	10 900	89.3	38	1.22	109.4	125.9	102	132.5	1.5	1	HTA018UADB	
HTA019UADB	95	145	45	1.5	1	56.0	131	5 700	13 400	66.0	6 750	8 300	10 400	92.1	39	1.27	114.4	130.9	107	137.5	1.5	1	HTA019UADB	
HTA020UADB	100	150	45	1.5	1	58.0	140	5 900	14 300	71.0	7 250	8 000	10 000	95.1	39	1.34	119.5	135.9	112	142.5	1.5	1	HTA020UADB	
HTA021UADB	105	160	49.5	2	1	66.5	163	6 800	16 600	82.5	8 400	7 500	9 400	101.6	49	1.74	126.5	144.3	119	152.5	2	1	HTA021UADB	
HTA022UADB	110	170	54	2	1	82.5	200	8 400	20 400	100	10 200	7 100	8 900	108.3	66	2.14	133.1	153.4	124	162.5	2	1	HTA022UADB	
HTA024UADB	120	180	54	2	1	83.0	206	8 450	21 000	104	10 600	6 700	8 300	114.1	67	2.32	143.3	163.5	134	172.5	2	1	HTA024UADB	
HTA026UADB	130	200	63	2	1	119	293	12 200	29 900	144	14 700	6 100	7 600	127.3	108	3.39	156.4	181.7	144	192.5	2	1	HTA026UADB	
HTA028UADB	140	210	63	2	1	123	315	12 600	32 000	156	15 900	5 700	7 100	133.1	114	3.60	166.4	191.7	154	202.5	2	1	HTA028UADB	
HTA030UADB	150	225	67.5	2.1	1.1	127	330	12 900	34 000	169	17 200	5 300	6 700	142.6	141	4.46	178.9	204.3	167	215	2	1	HTA030UADB	
HTA032UADB	160	240	72	2.1	1.1	148	390	15 100	40 000	196	20 000	5 000	6 300	152.1	168	5.40	190.6	218.5	177	230	2	1	HTA032UADB	
HTA034UADB	170	260	81	2.1	1.1	170	450	17 400	46 000	226	23 000	4 700	5 800	165.3	238	7.20	204.7	235.3	187	250	2	1	HTA034UADB	
HTA036UADB	180	280	90	2.1	1.1	197	530	20 100	54 000	265	27 000	4 300	5 400	178.5	285	10.6	218.9	251.7	197	270	2	1	HTA036UADB	
HTA038UADB	190	290	91	2.1	1.1	200	545	20 400	55 500	275	28 000	4 200	5 200	184.3	300	11.0	228.9	261.7	207	280	2	1	HTA038UADB	
HTA040UADB	200	310	99	2.1	1.1	224	610	22 800	62 500	310	31 500	3 900	4 900	197.5	436	13.8	243.0	278.5	217	300	2	1	HTA040UADB	
HTA044UADB	220	340	108	3	1.1	281	775	28 600	79 000	385	39 500	3 600	4 500	216.6	550	18.1	266.3	306.9	240	330	2.5	1	HTA044UADB	
HTA048UADB	240	360	108	3	1.1	289	825	29 500	84 000	415	42 500	3 300	4 200	228.1	650	18.9	286.3	326.8	260	350	2.5	1	HTA048UADB	
HTA052UADB	260	400	123	4	1.5	345	1 040	35 000	106 000	520	53 500	3 000	3 800	253.0	850	28.4	314.6	360.3	283	388	3	1.5	HTA052UADB	
HTA056UADB	280	420	123	4	1.5	350	1 110	36 000	113 000	565	57 500	2 900	3 600	264.6	900	30.2	334.6	380.3	303	408	3	1.5	HTA056UADB	
HTA060UADB	300	460	142.5	4	1.5	400	1 330	41 000	135 000	670	68 500	2 600	3 300	291.8	1 265	43.6	362.9	414.0	323	448	3	1.5	HTA060UADB	
HTA064UADB	320	480	142.5	4	1.5	405	1 360	41 500	139 000	700	71 500	2 500	3 100	303.3	1 340	45.8	382.9	433.9	343	468	3	1.5	HTA064UADB	

1) Minimum allowable value for corner radius dimension r or r₁.

Main Spindle Bearings

Main Spindle Bearings

Angular Contact Ball Bearings for Axial Loads

ULTAGE Angular contact ball bearings for axial loads (steel ball spec.)
HTA0U type

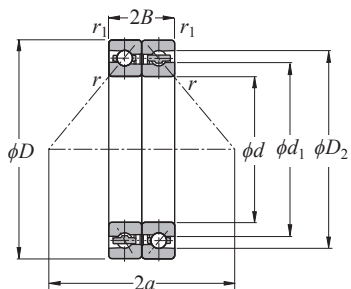

Contact angle 40° d 50–320 mm

Part number	Boundary dimensions					Basic load ratings				Allowable axial load		Allowable speed		Load center mm 2a	Internal free space cm ³ Two row (approx.)	Mass kg Two row (approx.)	Reference dimensions		Abutment and fillet dimensions				Part number
	mm					dynamic	static	dynamic	static	kN	kgf	grease	oil				mm		mm				
	d	D	2B	r _{s min} ¹⁾	r _{1s min} ¹⁾	C _a	C _{0a}	C _a	C _{0a}	(kN)	(kgf)	lubrication	lubrication				d ₁	D ₂	d _{a min}	D _{b max}	r _{as max}	r _{1as max}	
HTA010UDB	50	80	28.5	1	0.6	33.0	55.5	3 350	5 650	12.3	1 250	11 500	14 600	69.2	9	0.24	60.7	73.1	57.5	74.0	1	0.6	HTA010UDB
HTA011UDB	55	90	33	1.1	0.6	35.5	64.0	3 600	6 500	14.3	1 460	10 300	13 100	77.7	13	0.39	68.2	80.7	65.0	84.0	1	0.6	HTA011UDB
HTA012UDB	60	95	33	1.1	0.6	37.0	69.5	3 800	7 100	15.7	1 600	9 700	12 300	81.9	13	0.41	73.2	85.7	70.0	89.0	1	0.6	HTA012UDB
HTA013UDB	65	100	33	1.1	0.6	37.5	72.0	3 850	7 350	16.4	1 670	9 100	11 500	86.1	14	0.44	78.2	90.7	75.0	94.0	1	0.6	HTA013UDB
HTA014UDB	70	110	36	1.1	0.6	46.0	91.0	4 700	9 300	21.5	2 190	8 300	10 600	94.0	18	0.61	85.3	99.0	80.0	104	1	0.6	HTA014UDB
HTA015UDB	75	115	36	1.1	0.6	49.0	101	5 000	10 300	24.0	2 450	7 900	10 000	98.2	19	0.65	90.3	104.0	85.0	109	1	0.6	HTA015UDB
HTA016UDB	80	125	40.5	1.1	0.6	56.0	117	5 700	11 900	28.4	2 900	7 300	9 300	106.7	26	0.88	97.4	112.4	90.0	119	1	0.6	HTA016UDB
HTA017UDB	85	130	40.5	1.1	0.6	56.5	120	5 800	12 300	29.4	3 000	7 000	8 800	110.9	28	0.93	102.4	117.4	95.0	124	1	0.6	HTA017UDB
HTA018UDB	90	140	45	1.5	1	65.5	141	6 700	14 400	32.0	3 250	6 500	8 300	119.5	38	1.22	109.4	125.8	102	132.5	1.5	1	HTA018UDB
HTA019UDB	95	145	45	1.5	1	66.5	146	6 800	14 900	33.5	3 400	6 300	7 900	123.7	39	1.27	114.4	130.8	107	137.5	1.5	1	HTA019UDB
HTA020UDB	100	150	45	1.5	1	68.5	156	7 000	15 900	35.5	3 600	6 000	7 600	128.0	39	1.34	119.5	135.9	112	142.5	1.5	1	HTA020UDB
HTA021UDB	105	160	49.5	2	1	79.0	181	8 050	18 400	42.5	4 350	5 700	7 200	136.5	49	1.74	126.5	144.2	119	152.5	2	1	HTA021UDB
HTA022UDB	110	170	54	2	1	98.0	222	10 000	22 700	50.0	5 100	5 400	6 800	145.1	66	2.14	133.1	153.3	124	162.5	2	1	HTA022UDB
HTA024UDB	120	180	54	2	1	98.5	228	10 000	23 300	52.0	5 300	5 000	6 300	153.6	67	2.32	143.3	163.4	134	172.5	2	1	HTA024UDB
HTA026UDB	130	200	63	2	1	142	325	14 400	33 000	74.0	7 550	4 500	5 800	170.8	108	3.39	156.4	181.6	144	192.5	2	1	HTA026UDB
HTA028UDB	140	210	63	2	1	146	345	14 900	35 500	79.5	8 100	4 300	5 400	179.2	114	3.60	166.4	191.6	154	202.5	2	1	HTA028UDB
HTA030UDB	150	225	67.5	2.1	1.1	150	370	15 300	37 500	85.0	8 650	4 000	5 200	191.9	141	4.46	178.9	204.2	167	215	2	1	HTA030UDB
HTA032UDB	160	240	72	2.1	1.1	176	435	17 900	44 000	103	10 500	3 800	4 800	204.7	168	5.40	190.6	218.4	177	230	2	1	HTA032UDB
HTA034UDB	170	260	81	2.1	1.1	202	500	20 600	51 000	116	11 800	3 500	4 400	221.9	238	7.20	204.7	235.2	187	250	2	1	HTA034UDB
HTA036UDB	180	280	90	2.1	1.1	234	585	23 900	60 000	140	14 300	3 300	4 100	239.1	285	10.6	218.9	251.6	197	270	2	1	HTA036UDB
HTA038UDB	190	290	91	2.1	1.1	237	605	24 100	61 500	145	14 800	3 100	4 000	247.4	300	11.0	228.9	261.6	207	280	2	1	HTA038UDB
HTA040UDB	200	310	99	2.1	1.1	265	680	27 100	69 000	159	16 200	2 900	3 700	264.6	436	13.8	243.0	278.4	217	300	2	1	HTA040UDB
HTA044UDB	220	340	108	3	1.1	335	860	34 000	87 500	201	20 500	2 700	3 400	290.3	550	18.1	266.3	306.7	240	330	2.5	1	HTA044UDB
HTA048UDB	240	360	108	3	1.1	345	915	35 000	93 000	216	22 000	2 500	3 200	307.0	650	18.9	286.3	326.6	260	350	2.5	1	HTA048UDB
HTA052UDB	260	400	123	4	1.5	405	1 160	41 500	118 000	275	28 000	2 300	2 900	339.9	850	28.4	314.6	360.1	283	388	3	1.5	HTA052UDB
HTA056UDB	280	420	123	4	1.5	420	1 230	42 500	125 000	293	29 900	2 100	2 700	356.7	900	30.2	334.6	380.1	303	408	3	1.5	HTA056UDB
HTA060UDB	300	460	142.5	4	1.5	475	1 470	48 500	150 000	355	36 000	2 000	2 500	391.7	1 265	43.6	362.9	413.7	323	448	3	1.5	HTA060UDB
HTA064UDB	320	480	142.5	4	1.5	480	1 520	49 000	155 000	365	37 000	1 900	2 400	408.5	1 340	45.8	382.9	433.7	343	468	3	1.5	HTA064UDB

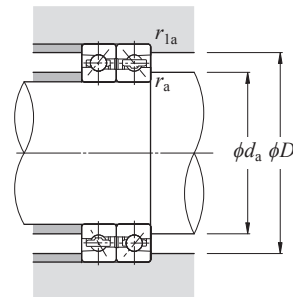

Dynamic equivalent axial load
 $P_a = F_a$

Static equivalent axial load
 $P_{0a} = F_a$

1) Minimum allowable value for corner radius dimension r or r₁.

Angular Contact Ball Bearings for Axial Loads

Dimension Tables



ULTAGE Angular contact ball bearings for axial loads (ceramic ball spec.)
5S-HTA0UA type

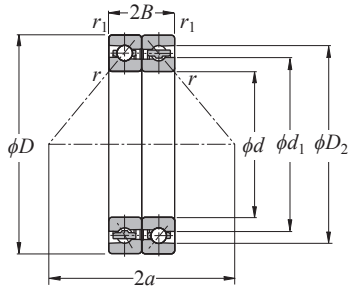

Angular Contact Ball Bearings for Axial Loads

Dimension Tables

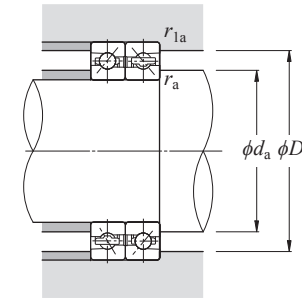

Dynamic equivalent axial load
 $P_a = F_a$

Static equivalent axial load
 $P_{0a} = F_a$

Contact angle 30° d 50–130 mm

Part number	Boundary dimensions					Basic load ratings				Allowable axial load		Allowable speed		Load center mm $2a$	Internal free space cm ³ Two row (approx.)	Mass kg Two row (approx.)	Reference dimensions		Abutment and fillet dimensions				Part number
	mm					dynamic	static	dynamic	static	kN	kgf	grease lubrication	oil lubrication				mm	mm	d_a	D_b	r_{as}	r_{1as}	
	d	D	$2B$	$r_s \text{ min}^{-1}$	$r_{1s} \text{ min}^{-1}$	C_a	C_{0a}	C_a	C_{0a}	(kN)	(kgf)	min ⁻¹	min ⁻¹				d_1	D_2	min	max	max	max	
5S-HTA010UADB	50	80	28.5	1	0.6	27.5	33.5	2 810	3 400	15.7	1 600	17 300	22 200	52.1	9	0.22	60.7	73.2	57.5	74.0	1	0.6	5S-HTA010UADB
5S-HTA011UADB	55	90	33	1.1	0.6	29.8	39.5	3 050	4 050	18.6	1 900	15 500	19 900	58.6	13	0.36	68.2	80.8	65.0	84.0	1	0.6	5S-HTA011UADB
5S-HTA012UADB	60	95	33	1.1	0.6	31.0	43.5	3 200	4 450	20.5	2 090	14 500	18 600	61.5	13	0.39	73.2	85.8	70.0	89.0	1	0.6	5S-HTA012UADB
5S-HTA013UADB	65	100	33	1.1	0.6	31.5	45.0	3 250	4 600	21.6	2 200	13 600	17 500	64.4	14	0.41	78.2	90.8	75.0	94.0	1	0.6	5S-HTA013UADB
5S-HTA014UADB	70	110	36	1.1	0.6	38.5	57.0	3 950	5 800	27.2	2 770	12 500	16 000	70.3	18	0.57	85.3	99.1	80.0	104	1	0.6	5S-HTA014UADB
5S-HTA015UADB	75	115	36	1.1	0.6	41.0	63.5	4 200	6 450	30.5	3 150	11 800	15 200	73.2	19	0.60	90.3	104.1	85.0	109	1	0.6	5S-HTA015UADB
5S-HTA016UADB	80	125	40.5	1.1	0.6	47.0	73.0	4 800	7 400	35.0	3 600	11 000	14 100	79.8	26	0.83	97.4	112.5	90.0	119	1	0.6	5S-HTA016UADB
5S-HTA017UADB	85	130	40.5	1.1	0.6	48.0	75.0	4 850	7 650	36.5	3 750	10 500	13 400	82.7	28	0.87	102.4	117.5	95.0	124	1	0.6	5S-HTA017UADB
5S-HTA018UADB	90	140	45	1.5	1	55.5	88.5	5 650	9 000	43.0	4 400	9 800	12 500	89.3	38	1.15	109.4	125.9	102	132.5	1.5	1	5S-HTA018UADB
5S-HTA019UADB	95	145	45	1.5	1	56.0	91.0	5 700	9 300	44.5	4 550	9 400	12 000	92.1	39	1.20	114.4	130.9	107	137.5	1.5	1	5S-HTA019UADB
5S-HTA020UADB	100	150	45	1.5	1	58.0	97.0	5 900	9 900	48.0	4 900	9 000	11 500	95.1	39	1.26	119.5	135.9	112	142.5	1.5	1	5S-HTA020UADB
5S-HTA021UADB	105	160	49.5	2	1	66.5	113	6 800	11 500	55.5	5 650	8 500	10 900	101.6	49	1.64	126.5	144.3	119	152.5	2	1	5S-HTA021UADB
5S-HTA022UADB	110	170	54	2	1	82.5	139	8 400	14 100	67.0	6 850	8 000	10 300	108.3	66	2.00	133.1	153.4	124	162.5	2	1	5S-HTA022UADB
5S-HTA024UADB	120	180	54	2	1	83.0	143	8 450	14 500	70.0	7 150	7 500	9 600	114.1	67	2.17	143.3	163.5	134	172.5	2	1	5S-HTA024UADB
5S-HTA026UADB	130	200	63	2	1	119	203	12 200	20 700	97.0	9 900	6 800	8 700	127.3	108	3.13	156.4	181.7	144	192.5	2	1	5S-HTA026UADB

1) Minimum allowable value for corner radius dimension r or r_1 .

Main Spindle Bearings

Main Spindle Bearings

Angular Contact Ball Bearings for Axial Loads

ULTAGE Angular contact ball bearings for axial loads (ceramic ball spec.)
5S-HTA0U type

Dimension Tables

NTN

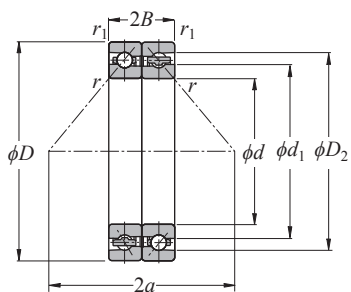

Angular Contact Ball Bearings for Axial Loads

Dimension Tables

NTN

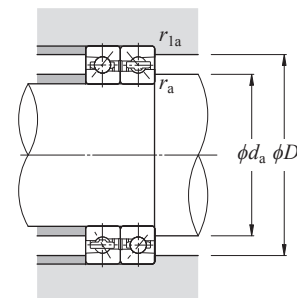

Dynamic equivalent axial load
 $P_a = F_a$

Static equivalent axial load
 $P_{0a} = F_a$

Contact angle 40° d 50–130 mm

Part number	Boundary dimensions					Basic load ratings				Allowable axial load		Allowable speed		Load center mm 2a	Internal free space cm ³ Two row (approx.)	Mass kg Two row (approx.)	Reference dimensions		Abutment and fillet dimensions				Part number
	mm					dynamic	static	dynamic	static	kN	kgf	grease lubrication	oil lubrication				mm	mm	mm				
	d	D	2B	$r_s \text{ min}^{-1}$	$r_{1s} \text{ min}^{-1}$	C_a	C_{0a}	C_a	C_{0a}	(static)								d_1	D_2	d_a min	D_b max	r_{as} max	
5S-HTA010UDB	50	80	28.5	1	0.6	33.0	38.5	3 350	3 900	14.6	1 490	12 200	15 400	69.2	9	0.22	60.7	73.1	57.5	74.0	1	0.6	5S-HTA010UDB
5S-HTA011UDB	55	90	33	1.1	0.6	35.5	44.5	3 600	4 500	17.1	1 740	10 900	13 800	77.7	13	0.36	68.2	80.7	65.0	84.0	1	0.6	5S-HTA011UDB
5S-HTA012UDB	60	95	33	1.1	0.6	37.0	48.0	3 800	4 900	18.7	1 910	10 200	12 900	81.9	13	0.39	73.2	85.7	70.0	89.0	1	0.6	5S-HTA012UDB
5S-HTA013UDB	65	100	33	1.1	0.6	37.5	50.0	3 850	5 100	19.6	2 000	9 600	12 100	86.1	14	0.41	78.2	90.7	75.0	94.0	1	0.6	5S-HTA013UDB
5S-HTA014UDB	70	110	36	1.1	0.6	46.0	63.0	4 700	6 450	25.6	2 610	8 800	11 100	94.0	18	0.57	85.3	99.0	80.0	104	1	0.6	5S-HTA014UDB
5S-HTA015UDB	75	115	36	1.1	0.6	49.0	70.5	5 000	7 150	28.7	2 930	8 300	10 500	98.2	19	0.60	90.3	104.0	85.0	109	1	0.6	5S-HTA015UDB
5S-HTA016UDB	80	125	40.5	1.1	0.6	56.0	81.0	5 700	8 250	34.0	3 450	7 700	9 800	106.7	26	0.83	97.4	112.4	90.0	119	1	0.6	5S-HTA016UDB
5S-HTA017UDB	85	130	40.5	1.1	0.6	56.5	83.5	5 800	8 500	35.0	3 600	7 300	9 300	110.9	28	0.87	102.4	117.4	95.0	124	1	0.6	5S-HTA017UDB
5S-HTA018UDB	90	140	45	1.5	1	65.5	98.0	6 700	10 000	38.0	3 900	6 900	8 700	119.5	38	1.15	109.4	125.8	102	132.5	1.5	1	5S-HTA018UDB
5S-HTA019UDB	95	145	45	1.5	1	66.5	101	6 800	10 300	39.5	4 050	6 600	8 300	123.7	39	1.20	114.4	130.8	107	137.5	1.5	1	5S-HTA019UDB
5S-HTA020UDB	100	150	45	1.5	1	68.5	108	7 000	11 000	42.5	4 300	6 300	8 000	128.0	39	1.26	119.5	135.9	112	142.5	1.5	1	5S-HTA020UDB
5S-HTA021UDB	105	160	49.5	2	1	79.0	125	8 050	12 800	50.5	5 150	6 000	7 500	136.5	49	1.64	126.5	144.2	119	152.5	2	1	5S-HTA021UDB
5S-HTA022UDB	110	170	54	2	1	98.0	154	10 000	15 700	59.5	6 100	5 600	7 100	145.1	66	2.00	133.1	153.3	124	162.5	2	1	5S-HTA022UDB
5S-HTA024UDB	120	180	54	2	1	98.5	158	10 000	16 100	61.5	6 300	5 300	6 700	153.6	67	2.17	143.3	163.4	134	172.5	2	1	5S-HTA024UDB
5S-HTA026UDB	130	200	63	2	1	142	225	14 400	23 000	88.0	9 000	4 800	6 100	170.8	108	3.13	156.4	181.6	144	192.5	2	1	5S-HTA026UDB

1) Minimum allowable value for corner radius dimension r or r₁.



Main Spindle Bearings

12. Tapered Roller Bearings CONTENTS

12.1 Load calculation	316
12.2 Bearing designation	316
12.3 Accuracy	317
12.4 Recommended fits for high-precision tapered roller bearings	317
Dimension Tables	318

12. Tapered Roller Bearings

Tapered roller bearings are designed so that the apexes of the inner ring, outer ring, and rollers are located at a common point on the bearing center line. Accordingly, the rollers roll on the raceway surfaces and slide along the back rib of the inner ring cone, guided by the combined force from the inner ring and outer ring raceways.

This bearing is suitable for handling a radial load, an axial load in one direction, and the combined load. Also, it has a large load capacity.

In general, pressed cages are used in tapered roller bearings. Care must be taken when designing the shaft and housing for such a bearing, because the cage protrudes from the side of the raceway surface.

12.1 Load calculation

Tapered roller bearings are generally used in pairs, so their dynamic equivalent load can be calculated according to Table 12.1.

Table 12.1 Bearing arrangement and equivalent load

Bearing arrangement	Load condition	Axial load	Equivalent radial load
DB arrangement 	$\frac{0.5F_{rI}}{Y_I} \leq \frac{0.5F_{rII}}{Y_{II}} + F_a$	$F_{aI} = \frac{0.5F_{rII}}{Y_{II}} + F_a$ $F_{aII} = \frac{0.5F_{rII}}{Y_{II}}$	$P_{rI} = X F_{rI} + Y_I \left[\frac{0.5F_{rII}}{Y_{II}} + F_a \right]$ $P_{rII} = F_{rII}$
DF arrangement 	$\frac{0.5F_{rI}}{Y_I} > \frac{0.5F_{rII}}{Y_{II}} + F_a$	$F_{aI} = \frac{0.5F_{rI}}{Y_I}$ $F_{aII} = \frac{0.5F_{rI}}{Y_I} - F_a$	$P_{rI} = F_{rI}$ $P_{rII} = X F_{rII} + Y_{II} \left[\frac{0.5F_{rI}}{Y_I} - F_a \right]$
DB arrangement 	$\frac{0.5F_{rII}}{Y_{II}} \leq \frac{0.5F_{rI}}{Y_I} + F_a$	$F_{aI} = \frac{0.5F_{rI}}{Y_I}$ $F_{aII} = \frac{0.5F_{rI}}{Y_I} + F_a$	$P_{rI} = F_{rI}$ $P_{rII} = X F_{rII} + Y_{II} \left[\frac{0.5F_{rI}}{Y_I} + F_a \right]$
DF arrangement 	$\frac{0.5F_{rII}}{Y_{II}} > \frac{0.5F_{rI}}{Y_I} + F_a$	$F_{aI} = \frac{0.5F_{rII}}{Y_{II}} - F_a$ $F_{aII} = \frac{0.5F_{rII}}{Y_{II}}$	$P_{rI} = X F_{rI} + Y_I \left[\frac{0.5F_{rII}}{Y_{II}} - F_a \right]$ $P_{rII} = F_{rII}$

Note 1: The above are valid when the bearing internal clearance and preload are zero.
 2: Radial load in the opposite direction to the arrow in the above illustration are also regarded as positive.

12.2 Bearing designations

329 18 X U DB +xx P5

- 329**: Nominal bore diameter
- 18**: Nominal bore diameter
- X**: Internal modification code
- U**: Duplex arrangement code (DB: Back-to-back, DF: Face-to-face)
- DB**: Duplex arrangement code
- +xx**: Tolerance class code (P5: JIS Class 5, P4: JIS Class 4)
- P5**: Tolerance class code

12.3 Accuracy

Table 12.2 Inner rings

Unit: μm

Nominal bore diameter <i>d</i> mm over incl.	Deviation of mean bore diameter in a single plane Δ_{dmp}		Variation of bore diameter in a single plane V_{dsp}		Variation of mean bore diameter V_{dmp}		Radial runout of inner ring of assembled bearing K_{ia}		Perpendicularity of inner ring face with respect to the bore S_D		Axial runout of inner ring of assembled bearing S_{ia}		Deviation of a single inner ring width Δ_{Bs}		Deviation of the actual assembled bearing width Δ_{Ts}						
	Class 5 high	Class 4 low	Class 5 max	Class 4 max	Class 5 max	Class 4 max	Class 5 max	Class 4 max	Class 5 max	Class 4 max	Class 5 max	Class 4 max	Class 5 high	Class 4 low	Class 5 high	Class 4 low					
18 30	0	-8	0	-6	6	5	5	4	5	3	8	4	4	0	-200	0	-200	+200	-200	+200	-200
30 50	0	-10	0	-8	8	6	5	5	6	4	8	4	4	0	-240	0	-240	+200	-200	+200	-200
50 80	0	-12	0	-9	9	7	6	5	7	4	8	5	4	0	-300	0	-300	+200	-200	+200	-200
80 120	0	-15	0	-10	11	8	8	5	8	5	9	5	5	0	-400	0	-400	+200	-200	+200	-200
120 180	0	-18	—	—	14	—	9	—	11	—	10	—	—	0	-500	—	—	+350	-250	—	—
180 250	0	-22	—	—	17	—	11	—	13	—	11	—	—	0	-600	—	—	+350	-250	—	—

1) The dimensional difference Δ_{ds} of the measured bore diameter applied to Class 4 is the same as the tolerance of dimensional difference Δ_{dmp} of the mean bore diameter within a plane.

Table 12.3 Outer rings

Unit: μm

Nominal outside diameter <i>D</i> mm over incl.	Deviation of mean outside diameter in a single plane Δ_{Dmp}		Variation of outside diameter in a single plane V_{Dsp}		Variation of mean outside diameter V_{Dmp}		Radial runout of outer ring of assembled bearing K_{ea}		Perpendicularity of outer ring outside surface with respect to the face S_D		Axial runout of outer ring of assembled bearing S_{ea}		Deviation of a single outer ring width Δ_{Cs}	
	Class 5 high	Class 4 low	Class 5 max	Class 4 max	Class 5 max	Class 4 max	Class 5 max	Class 4 max	Class 5 max	Class 4 max	Class 5 max	Class 4 max	Class 5 high	Class 4 low
30 50	0	-9	0	-7	7	5	5	5	7	5	8	4	5	Depends on tolerance of Δ_{Bs} in relation to <i>d</i> of the same bearing
50 80	0	-11	0	-9	8	7	6	5	8	5	8	4	5	
80 120	0	-13	0	-10	10	8	7	5	10	6	9	5	6	
120 150	0	-15	0	-11	11	8	8	6	11	7	10	5	7	
150 180	0	-18	0	-13	14	10	9	7	13	8	10	5	8	
180 250	0	-20	—	—	15	—	10	—	15	—	11	—	—	
250 315	0	-25	—	—	19	—	13	—	18	—	13	—	—	

2) The dimensional difference Δ_{Ds} of the measured outside diameter applied to Class 4 is the same as the tolerance of dimensional difference Δ_{Dmp} of the mean outside diameter within a plane.

12.4 Recommended fits for high-precision tapered roller bearings

Table 12.4 Shaft fits

Unit: μm

Nominal bore diameter <i>d</i> (mm) over incl.		Fits between inner ring and shaft	
		Fixed side	Floating side
		Targeted ¹⁾ interference	Targeted ¹⁾ interference
18	30	0- 5T	0-1T
30	50	0- 6T	0-2T
50	80	0- 7T	0-3T
80	120	0- 8T	0-4T
120	180	0-10T	0-5T
180	250	0-13T	0-6T
250	315	0-15T	0-6T
315	400	0-18T	0-8T

1) It is recommended to use the median value.
 T: Tight (Interference) fit

Table 12.5 Housing fits

Unit: μm

Nominal outside diameter <i>D</i> (mm) over incl.		Fits between outer ring and housing	
		Targeted interference ¹⁾	
30	50	3L-3T	
50	80	3L-3T	
80	120	4L-4T	
120	150	5L-5T	
150	180	5L-5T	
180	250	6L-6T	
250	315	7L-7T	
315	400	8L-8T	
400	500	9L-9T	

1) For high precision main spindles, the tight (interference) fit side of the targeted interference is recommended for the main spindle tool side.
 L: Loose fit T: Tight (Interference) fit

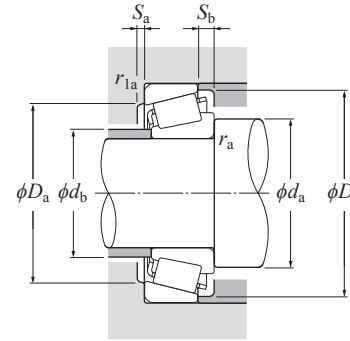
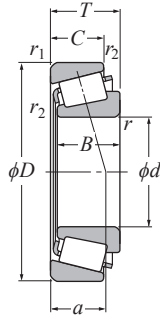

Dynamic equivalent radial load

$$P_r = X F_r + Y F_a$$

$\frac{F_a}{F_r} \leq e$		$\frac{F_a}{F_r} > e$	
X	Y	X	Y
1	0	0.4	Y ₂

Static equivalent radial load

$$P_{0r} = 0.5 F_r + Y_0 F_a$$

Note that when $P_{0r} < F_r$, $P_{0r} = F_r$.

The values for e , Y_2 and Y_0 are given in the table below.

d 95-190 mm

Part number	ISO Dimension series	Boundary dimensions								Basic load ratings				Allowable speed		Abutment and fillet dimensions						Load center mm	Factor	Axial load factor		Mass kg			
		mm								dynamic kN	static	dynamic kgf	static	min ⁻¹		mm								a	e		Y ₂	Y ₀	(approx.)
		d	D	T	B	C	r _{s min} ¹⁾	r _{1s min} ¹⁾	r _{2s min} ¹⁾	C _r	C _{0r}	C _r	C _{0r}	grease lubrication	oil lubrication	d _{a min}	d _{b max}	D _{a max}	D _{b min}	S _{a min}	S _{b min}								
32919XU	2BC	95	130	23	23	18	1.5	1.5	0.6	112	178	11 400	18 200	2 500	3 400	103.5	102	121.5	117	125.5	4	5	1.5	1.5	23.5	0.36	1.68	0.92	0.851
32019XU	4CC	95	145	32	32	24	2	1.5	0.6	190	280	19 400	28 600	2 300	3 100	105	105	136.5	126	140	6	8	2	1.5	31.5	0.44	1.36	0.75	1.85
32920XU	2CC	100	140	25	25	20	1.5	1.5	0.6	134	206	13 700	21 000	2 400	3 200	108.5	109	131.5	127.5	135.5	4	5	1.5	1.5	24.5	0.33	1.82	1	1.12
32020XU	4CC	100	150	32	32	24	2	1.5	0.6	188	281	19 200	28 600	2 200	3 000	110	109.5	141.5	130.5	145	6	8	2	1.5	32.5	0.46	1.31	0.72	1.91
32921XA ²⁾		105	145	25	25	20	1.5	1.5	0.6	139	219	14 200	22 400	2 300	3 000	113.5	113.5	136.5	131.5	140.5	5	5	1.5	1.5	25	0.34	1.76	0.97	1.2
32021XU	4DC	105	160	35	35	26	2.5	2	0.6	223	335	22 800	34 000	2 100	2 800	117	115.5	150	138.5	153.5	6	9	2	2	34.5	0.44	1.35	0.74	2.44
32922XA ²⁾		110	150	25	25	20	1.5	1.5	0.6	141	226	14 400	23 100	2 200	2 900	118.5	118.5	141.5	136.5	146	5	5	1.5	1.5	26.5	0.36	1.69	0.93	1.24
32022XU	4DC	110	170	38	38	29	2.5	2	0.6	261	390	26 600	39 500	2 000	2 700	122	122	160	147.5	164	7	9	2	2	36.5	0.43	1.39	0.77	3.07
32924XU	2CC	120	165	29	29	23	1.5	1.5	0.6	180	294	18 400	30 000	2 000	2 600	128.5	129.5	156.5	150	160	6	6	1.5	1.5	29.5	0.35	1.72	0.95	1.76
32024XU	4DC	120	180	38	38	29	2.5	2	0.6	272	420	27 700	43 000	1 800	2 500	132	131	170	156	174.5	7	9	2	2	39	0.46	1.31	0.72	3.29
32926XU	2CC	130	180	32	32	25	2	1.5	0.6	215	350	21 900	36 000	1 800	2 400	140	140.5	171.5	163	174	6	7	2	1.5	31.5	0.34	1.77	0.97	2.41
32026XU	4EC	130	200	45	45	34	2.5	2	0.6	350	545	36 000	55 500	1 700	2 200	142	144	190	173.5	193.5	8	11	2	2	43.5	0.43	1.38	0.76	5
32928XU	2CC	140	190	32	32	25	2	1.5	0.6	221	375	22 600	38 000	1 700	2 200	150	150	181.5	172.5	184	6	6	2	1.5	34	0.36	1.67	0.92	2.5
32028XU	4DC	140	210	45	45	34	2.5	2	0.6	365	580	37 500	59 500	1 600	2 100	152	153	200	182.5	203	8	11	2	2	46	0.46	1.31	0.72	5.32
32930XU	2DC	150	210	38	38	30	2.5	2	0.6	297	490	30 500	50 000	1 600	2 100	162	162	200	189.5	202	7	8	2	2	36.5	0.33	1.83	1.01	3.93
32030XU	4EC	150	225	48	48	36	3	2.5	1	410	655	42 000	67 000	1 400	1 900	164	164	213	195	217.5	8	12	2.5	2	49.5	0.46	1.31	0.72	6.45
32932XU	2DC	160	220	38	38	30	2.5	2	0.6	305	520	31 500	53 000	1 500	1 900	172	172	210	199	213	7	8	2	2	38.5	0.35	1.73	0.95	4.14
32032XU	4EC	160	240	51	51	38	3	2.5	1	485	790	49 500	80 500	1 400	1 800	174	174.5	228	208	231.5	8	13	2.5	2	52.5	0.46	1.31	0.72	7.86
32934XU	3DC	170	230	38	38	30	2.5	2	0.6	315	560	32 500	57 000	1 400	1 800	182	181	220	208	223.5	7	8	2	2	42.5	0.38	1.56	0.86	4.4
32034XU	4EC	170	260	57	57	43	3	2.5	1	555	895	56 500	91 000	1 300	1 700	184	187	248	224.5	250	10	14	2.5	2	56	0.44	1.35	0.74	10.6
32936XU	4DC	180	250	45	45	34	2.5	2	0.6	390	700	40 000	71 500	1 300	1 700	192	192	240	219.5	241.5	8	11	2	2	54	0.48	1.25	0.69	6.55
32938XU	4DC	190	260	45	45	34	2.5	2	0.6	390	710	40 000	72 000	1 200	1 600	202	201.5	250	230	251	8	11	2	2	55	0.48	1.26	0.69	6.82

1) Minimum allowable value for corner radius dimension r , r_1 or r_2 .
2) This bearing does not incorporate the subunit dimensions.



Ball Screw Support Bearings

13. Ball Screw Support Bearings CONTENTS

13.1	Angular contact thrust ball bearings BST	324
13.2	Double-row thrust angular contact ball bearing unit BSTU	330
13.3	Duplex angular contact ball bearings HT	332
13.4	Needle roller bearings with double-direction thrust needle roller bearings	
	AXN	332
	Needle roller bearings with double-direction thrust cylindrical roller bearings	
	ARN	332
13.5	Bearing designations	333
13.6	Bearing accuracy	334
13.7	Standard preload and axial rigidity	340
13.8	Shaft and housing fits	341
13.9	Applications	341
13.10	Starting torque of BST type	342
13.11	Recommended lubrication specifications	343

Dimension Tables

Angular contact thrust ball bearings	
BST and BST LXL types	344
2A-BST and 2A-BST LXL types	346
Double-row thrust angular contact ball bearing unit	
BSTU LLX type	350
Duplex angular contact ball bearings HT type	
HT type	354
Needle roller bearings with double-direction thrust needle roller bearings	
AXN type	356
Needle roller bearings with double-direction thrust cylindrical roller bearings	
ARN type	358

13. Ball Screw Support Bearings

NTN ball screw support bearings are dedicated bearings with optimized structures and function to support ball screws.

These bearings are categorized as shown in Table 13.1.

Table 13.1 Bearing types

Type code	Notes	Bore diameter (mm)
BST 2A-BST	Open type angular contact thrust ball bearing with 60° contact angle, generally used with grease lubrication	φ17-φ60
BST LXL/L588 2A-BST LXL/L588	Grease-lubricated sealed angular contact ball bearing with 60° contact angle	φ17-φ60
BSTU LLX/L588	Grease-lubricated sealed double-row thrust angular contact ball bearing unit with 60° contact angle	φ20-φ100
HT	Duplex angular contact ball bearing with 30° contact angle, generally used with grease lubrication	φ6-φ40
AXN	Needle roller bearing with double-direction thrust needle roller bearing, generally used with oil lubrication	φ20-φ50
ARN	Needle roller bearing with double-direction thrust cylindrical roller bearing, generally used with oil lubrication	φ20-φ70

13.1 ULTAGE Angular contact thrust ball bearings BST-1B (LXL/L588), 2A-BST-1B (LXL/L588)

The BST type incorporates the maximum possible number of small balls (compared with those of a standard bearing), has thicker inner and outer rings, and a larger contact angle of 60°. Additionally, since balls are used as the rolling elements, the starting torque of an angular contact thrust ball bearing is less than that of a roller bearing.

Open (BST and 2A-BST type) and light-contact seals (BST LXL and 2A-BST LXL type) are available and resin cages are standard.

The side faces of the bearing are flush ground to provide the same face height difference for both the front and back faces. Therefore, bearings with the same bearing number can be freely combined into DB, DBT and DTBT combinations, etc. (see Fig. 13.2).

Every single bearing is machined to the same face height so that when any arrangement is installed on a ballscrew the unit has optimal preload. For this reason, no time-consuming preload adjustment (adjustment with shims or tightening and loosening while measuring the starting torque) is necessary.

■ Features 2A-BST-1B (LXL/L588)

1. Unique heat treatment greatly improves resistance against rolling contact fatigue, leading to longer service life (approximately two times that of the conventional type).
2. Both sides are sealed to enhance contamination resistance and to preserve the grease (Light-contact seal type).
3. Urea based special grease of long life is used (Light-contact seal type).
4. The combination of a unique heat treatment and special grease reduces fretting (by 80 % or more for sliding mode, 90 % or more for rolling mode, compared to the conventional type) (Light-contact seal type).
5. Pre-greased bearings eliminate the need for further grease packing and allow easier handling (Light-contact seal type).

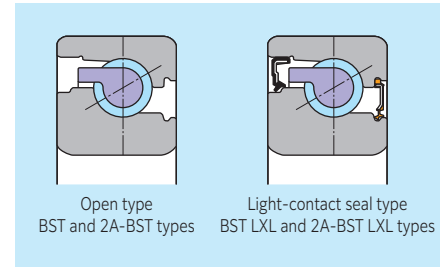

Fig. 13.1

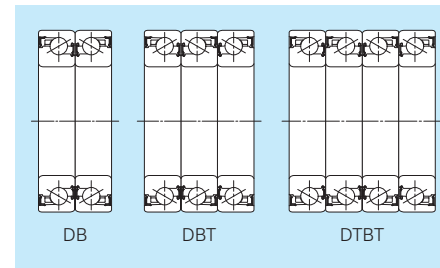
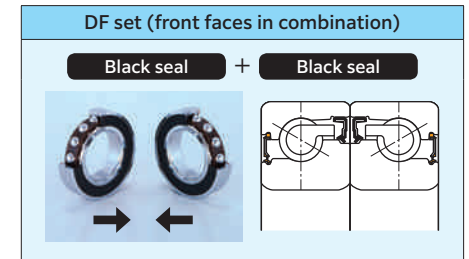
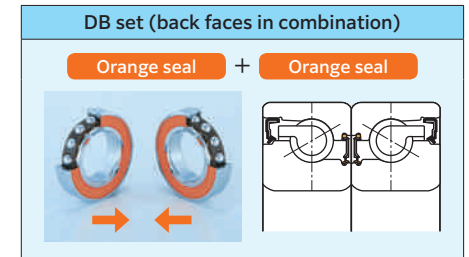

Fig. 13.2 Bearing arrangement

■ Easy handling

BST LXL and 2A-BST LXL types of grease-lubricated sealed angular contact ball bearings eliminate the need for grease filling because they have been packed with grease in advance. You need to only wipe away rust preventive oil before use. Seals in different colors are used for the front and back sides.

The front side (black) and back side (orange) can be identified by the color of a seal, and you can easily check configuration during assembly.



■ Performance tests

2A-BST-1B (LXL/L588) type bearings combine surface modification with urea based special grease to improve the bearing life and resistance to fretting.

(1) Fretting resistance test (sliding)

Resistance to fretting while sliding is tested by the fretting resistance test. A conceptual drawing of the test is shown in Fig. 13.3, and the test conditions are shown in Table 13.2. In this test, a fixed ball is pushed against a plate, and reciprocated for a fixed period. The volume of ball and plate wear depth are checked after testing as shown in Fig. 13.4.

Due to the combination of a unique heat treatment and a urea based special grease (light-contact seal type), amount of wear is reduced to 1/5 or less compared to the conventional type consisting of standard SUJ2 plate material and lithium based general purpose grease.

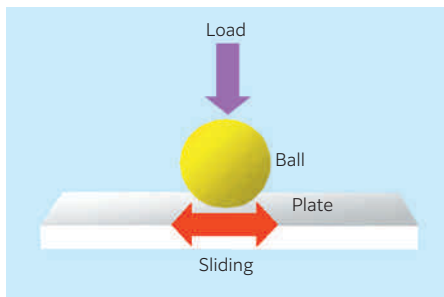

Fig. 13.3 Fretting resistance test (sliding)

Table 13.2 Test conditions

Specification	Conventional type	ULTAGE
Material/ Heat treatment	Plate	SUJ2/Standard
	Ball	SUJ2/Special
Lubrication	Grease	Lithium based general purpose
		Urea based special
Load	98 N	
Max. contact surface pressure	2 560 MPa	
Loading cycle (Time)	8.6 × 10 ⁵ cycle (8 h)	
Sliding cycle	30 Hz	
Amplitude	0.47 mm	
Temperature	Room temperature	

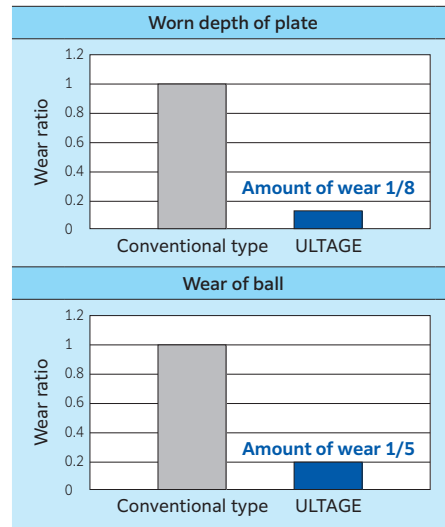

Fig. 13.4 Ratio of fretting corrosion in sliding mode

(2) Fretting resistance test (rolling)

Resistance against fretting while rolling is tested in the rotating and oscillating type fretting corrosion test. A conceptual drawing of the test is shown in Fig. 13.5, and the test conditions are shown in Table 13.3. In this test, a housing raceway washer is fixed, and the shaft raceway washer oscillates. The decrease in the weight of the bearing raceway washer after the test is shown in Fig. 13.6.

Due to the combination of a unique heat treatment and a urea based special grease (light-contact seal type), the amount of wear is reduced to 1/10 or less compared to the conventional type consisting of standard SUJ2 steel rings and lithium based general purpose grease.

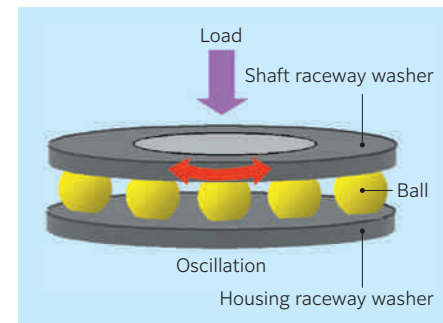

Fig. 13.5 Fretting resistance test (rolling)

Table 13.3 Test conditions

Specification	Conventional type	ULTAGE
Bearing	Thrust ball bearing 51204 (φ20 × φ40 × 14)	
Material/ Heat treatment	Raceway washer	SUJ2/Standard
	Ball	SUJ2/Special
Lubrication	Grease	Lithium based general purpose
		Urea based special
Load	2.5 kN	
Max. contact surface pressure	1 700 MPa	
Test time	8 h	
Oscillating cycle	30 Hz	
Oscillating angle	12°	
Temperature	Room temperature	

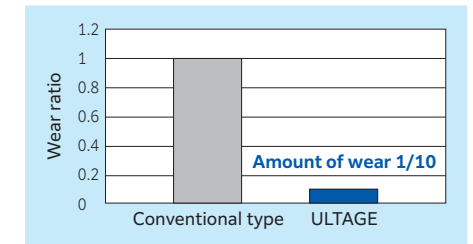

Fig. 13.6 Ratio of fretting corrosion while rolling

(3) Rolling contact fatigue life test

Resistance to rolling contact fatigue life is improved as a result of a special heat treatment, leading to a longer service life compared to the standard heat-treated type model in both clean and contaminated oil (see Fig. 13.7).

Table 13.4 Test conditions

Specification		Conventional type	ULTAGE
Bearing		Deep groove ball bearing 6206 ($\phi 30 \times \phi 62 \times 16$)	
Material/Heat treatment	Raceway ring	SUJ2/Standard	SUJ2/Special
	Ball	SUJ2/Standard	
Lubrication	Oil	Turbine oil ISO VG56	
Radial load		6.86 kN	
Speed		2 000 min ⁻¹	
Atmosphere temperature		60 °C	

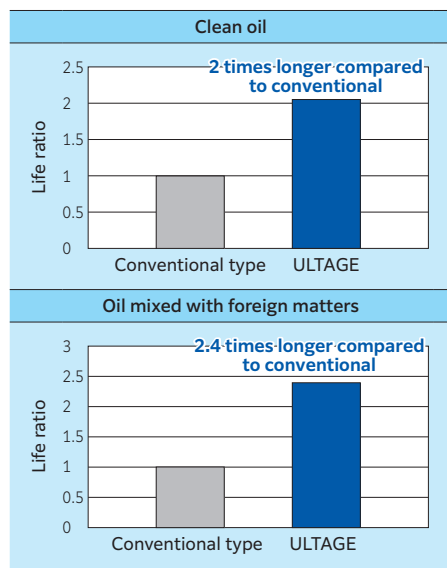

Fig. 13.7 Effect of special heat treatment on rolling contact fatigue life

(4) Grease life test

Service life of the grease has been dramatically extended compared to lithium-based general purpose grease (see Fig. 13.8).

Table 13.5 Test conditions

Specification		Conventional type	ULTAGE
Bearing		Deep groove ball bearing TS3-6204ZC3 ($\phi 20 \times \phi 47 \times 14$)	
Lubrication	Grease	Lithium based general purpose	Urea based special
Radial load		67 N	
Axial load		67 N	
Speed		10 000 min ⁻¹	
Atmosphere temperature		150 °C	

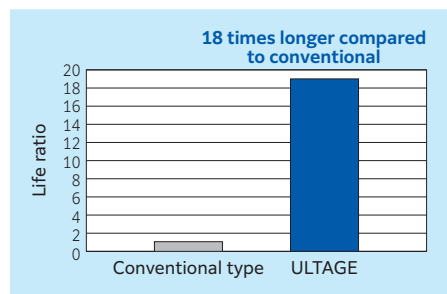

Fig. 13.8 Grease life ratio

(5) Grease leakage test

Light-contact type seals eliminate grease leakage from the bearing (see Fig. 13.9).

Table 13.6 Test conditions

Specification	ULTAGE
Bearing	Thrust angular contact ball bearing 2A-BST40X72-1BLXLD4/L588 ($\phi 40 \times \phi 72 \times 15$)
Lubrication Grease	Urea based special
Axial load	3.9 kN
Speed	1 000, 2 000, 3 000 min ⁻¹ running for two hours for each step
Atmosphere temperature	Room temperature

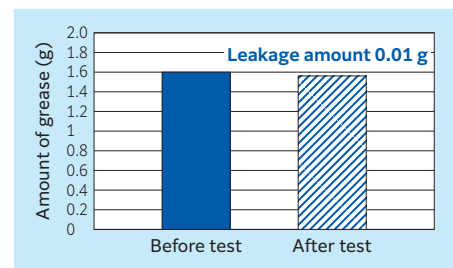

Fig. 13.9 Grease leakage

13.2 **ULTAGE** Double-row thrust angular contact ball bearing unit BSTU

The BSTU type is ball screw support bearing unit with two inner rings and one outer ring, in a back-to-back duplex arrangement. The outer ring has mounting holes for the housing for easier handling and the use of a newly developed seal ensures low torque and high dust resistance.

■ Features

1. Greater load capacity with optimizations made to the internal bearing design.
2. Use of newly developed light-contact seal to achieve both low torque and high dust resistance.
3. The long operating life of the BST type, and use of urea based special grease with excellent fretting resistance.
4. Outer ring mounting hole, and sealed grease lubrication for easier handling.
5. Specifications combining two of these units (D2) are also available for high-load capacity applications.

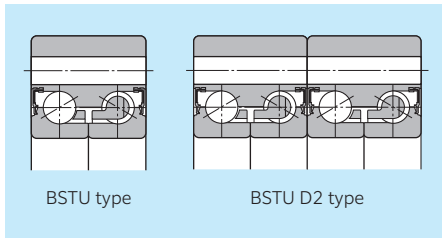

Fig. 13.10 BSTU

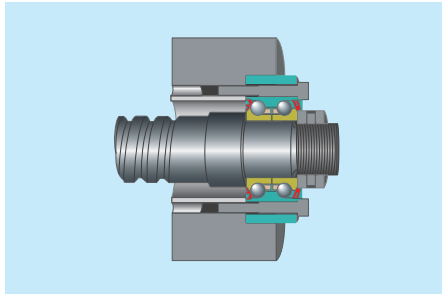

Fig. 13.11 Example of mounted BSTU type

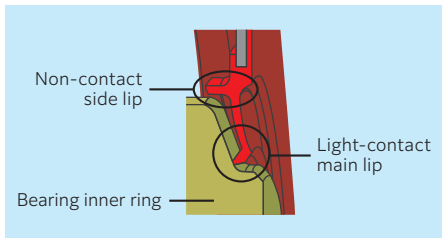

Fig. 13.12 Light-contact seal (code: LX)

■ Performance tests

(1) Bearing operating test

The BSTU type exhibit stable temperature rises up to 5 000 min⁻¹ ($d_{m,n}$ value 0.225×10^6) due to optimizations made to the internal bearing design and the use of a newly developed light-contact seal (see Fig. 13.13).

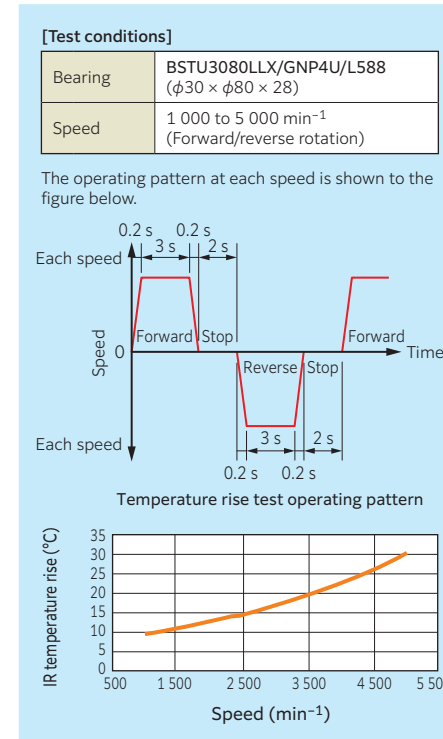

Fig. 13.13 Relation between speed and temperature rise

(2) Torque test, dust test

The BSTU type limits starting torque and has better dust resistance with the use of a newly developed light-contact seal (see Fig. 13.14, Fig. 13.15).

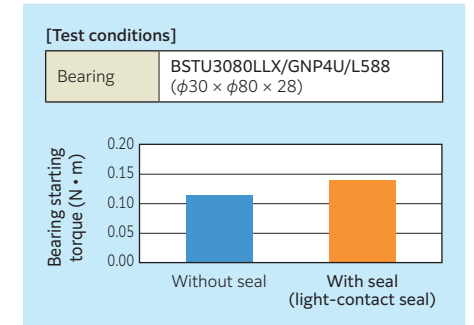

Fig. 13.14 Bearing starting torque

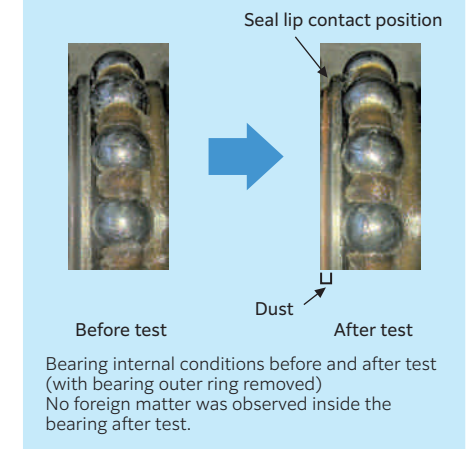
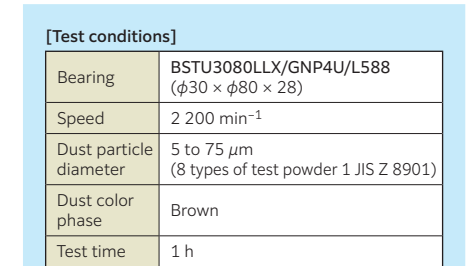

Fig. 13.15 Dust test results

13.3 Duplex angular contact ball bearings HT

HT type duplex angular contact ball bearings feature larger axial load capacity while maintaining the same dimensions as a standard angular contact ball bearing (contact angle: 30°). Bearings smaller than the BST type are available for use in small machines.

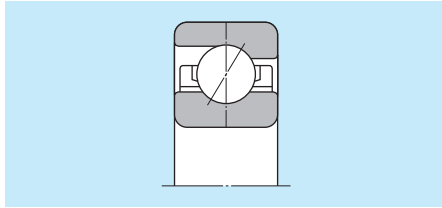

Fig. 13.16 HT

13.4 Needle roller bearings with double-direction thrust needle roller bearings AXN Needle roller bearings with double-direction thrust cylindrical roller bearings ARN

AXN and ARN types bearings have thrust needle roller or thrust cylindrical roller bearings on both sides of a radial needle roller bearing. The outer ring side face of the radial needle roller bearing is used as the raceway of both thrust bearings. These bearings can withstand axial loads in both directions while maintaining compact designs. The radial needle roller bearings are suitable for heavy radial loads.

The axial rigidity of the AXN type is extremely enhanced since the thrust needle roller bearings are used for axial loads.

Likewise, the axial rigidity of the ARN type is improved. Since the axial load capacity of this type is larger than the AXN type, this type is suitable for heavy axial loads. Oil lubrication is recommended for the ARN type.

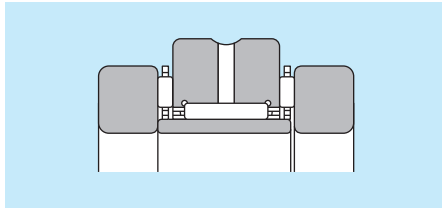

Fig. 13.17 AXN

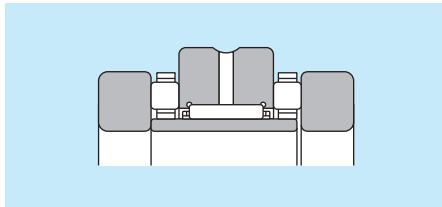

Fig. 13.18 ARN

13.5 Bearing designations

The part number for a ballscrew bearing consists of a type code, dimension code, and various suffixes.

■ BST type

2A - BST 20 × 47 -1B LXL DBT P4 / L588

- Grease code L588: Urea based special grease
- Tolerance class code P5: NTN Class 5
P4: NTN Class 4
UP: Special high precision
- Arrangement code
- Seal code LXL: Light contact rubber seal on both sides
- Identification code
Preload code and added number
-1B: Standard preload
-11B: Light preload
- Outside diameter (mm)
- Nominal bore diameter (mm)
- Bearing type code
- Heat treatment

■ HT type

7 0 04 HT DF / GM P4

- Tolerance class code
P5: JIS Class 5
P4: JIS Class 4
- Internal clearance code
GM: Medium preload
GH: Heavy preload
- Arrangement code
- Internal design code
- Nominal bore diameter
(See dimension table)
- Dimension series code
- Bearing type code

■ AXN and ARN types

AXN 2052 P4

- Tolerance class code
P5: NTN Class 5
P4: NTN Class 4
- Dimension
Bore diameter,
outside diameter (mm)
- Bearing type code
AXN
ARN

■ BSTU type

**P4U
BSTU 30 80 LLX N DX D2 /GN P42U /L588**

- Grease code
- Tolerance class code
- Preload code
- Arrangement code
- Outer ring re-lubricating hole
- Outer ring pullout groove
- Seal code
- Outside diameter (mm)
- Nominal bore diameter (mm)
- Bearing type code

13.6 Bearing accuracy

The precision of ballscrew bearings varies depending on the bearing type.

- **BST type**
Available in NTN Class 5 (tolerance class code P5), Class 4 (tolerance class code P4) each complying with JIS standards, and grade UP (tolerance class code UP). The classes are listed in ascending order.
- **BSTU type**
NTN standard Class 4 (tolerance class code P4U) and Class 42 (tolerance class code P42U) complying with the JIS standards are available.
- **70HT type**
Same precision as the angular contact ball bearing for radial loads. Classes 5 and 4 are available.
- **AXN, ARN types**
NTN standard Classes 4 and 5 complying with the JIS standards are available.

■ Accuracy of BST type

Table 13.7 Inner rings

Unit: μm

Nominal bore diameter <i>d</i>	Deviation of mean bore diameter in a single plane Δ_{dmp}						Radial runout K_{ia}			Perpendicularity of inner ring face with respect to the bore S_d			Axial runout S_{ia}			Width deviation Δ_{Bs}			Width variation V_{Bs}			
	mm	Class 5		Class 4 ¹⁾		Class UP ¹⁾		Class 5	Class 4	Class UP	Class 5	Class 4	Class UP	Class 5	Class 4	Class UP	Class 5	Class 4	Class UP			
over incl.	high	low	high	low	high	low	max	max	max	max	max	max	max	max	max	max	max	max	max			
10 18	0	-5	0	-4	0	-3.5	3.5	3	2	7	3	2	5	3	2	0	-120	0	-100	5	2.5	2
18 30	0	-6	0	-5	0	-3.5	4	3	2	8	4	3	5	3	2	0	-120	0	-100	5	2.5	2
30 50	0	-8	0	-6	0	-5	5	4	3	8	4	3	6	3	2	0	-120	0	-100	5	3	2
50 80	0	-9	0	-7	0	-5	5	4	4	8	5	4	7	4	3	0	-150	0	-150	6	4	3

1) The dimensional difference Δ_{ds} of the measured bore diameter applied to Classes 4 and UP is the same as the tolerance of dimensional difference Δ_{dmp} of the mean bore diameter within a plane.

Table 13.8 Outer rings

Unit: μm

Nominal outside diameter <i>D</i>	Deviation of mean outside diameter in a single plane Δ_{Dmp}						Radial runout K_{ea}			Perpendicularity of outer ring outside surface with respect to the face S_D			Axial runout S_{ea}			Width deviation Δ_{Cs}			Width variation V_{Cs}		
	mm	Class 5		Class 4 ²⁾		Class UP ²⁾		Class 5	Class 4	Class UP	Class 5	Class 4	Class UP	All classes	All classes	Class 5	Class 4	Class UP			
over incl.	high	low	high	low	high	low	max	max	max	max	max	max	max	max	max	max	max				
30 50	0	-7	0	-6	0	-5	7	5	4	8	4	3	5	4	5	2.5	2				
50 80	0	-9	0	-7	0	-5	8	5	4	8	4	3	6	3	6	3	2				
80 120	0	-10	0	-8	0	-7	10	6	4	9	5	4	8	4	8	4	3				

2) The dimensional difference Δ_{Ds} of the measured outside diameter applied to Classes 4 and UP is the same as the tolerance of dimensional difference Δ_{Dmp} of the mean outside diameter within a plane.

Note: This standard is the NTN standard.

■ Accuracy of BSTU type (Class P42U)

Table 13.9 Inner rings

Unit: μm

Nominal bore diameter <i>d</i>	Deviation of mean bore diameter in a single plane Δ_{dmp}		Variation of bore diameter in a single plane V_{dsp}	Perpendicularity of inner ring face with respect to the bore V_{dmp}	Radial runout K_{ia}	Variation of mean bore diameter S_d	Axial runout S_{ia}	Deviation of a single inner ring width Δ_{Bs}		Width variation V_{Bs}
	high	low						high	low	
20	0	-5	2.5	2.5	3	4	2	0	-125	2
25	0	-5	2.5	2.5	3	4	2	0	-125	2
30	0	-5	2.5	2.5	3	4	2.5	0	-125	2.5
35	0	-5	2.5	2.5	4	4	2.5	0	-125	2.5
40	0	-5	2.5	2.5	4	4	2.5	0	-125	2.5
90	0	-8	4	4	5	5	3	0	-125	3
100	0	-8	4	4	5	5	3	0	-125	3

Table 13.10 Outer rings

Unit: μm

Nominal outside diameter <i>D</i>	Deviation of mean outside diameter in a single plane Δ_{Dmp}			Variation of outside diameter in a single plane V_{Dsp}	Perpendicularity of outer ring outside surface with respect to the face V_{Dmp}	Radial runout K_{ea}	Variation of mean outside diameter S_D	Axial runout S_{ea}	Deviation of a single outer ring width Δ_{Cs}		Width variation V_{Cs}
	high	low	max						high	low	
68	0	-10	3.5	3.5	5	4	5	0	-250	3	
75	0	-10	3.5	3.5	5	4	5	0	-250	3	
80	0	-10	3.5	3.5	5	4	5	0	-250	3	
90	0	-10	4	4	6	5	6	0	-250	4	
100	0	-10	4	4	6	5	6	0	-250	4	
115	0	-10	4	4	6	5	6	0	-250	4	
190	0	-15	8	6	10	7	10	0	-250	7	
200	0	-15	8	6	10	7	10	0	-250	7	

Note: This standard is the NTN standard.

■ Accuracy of BSTU type (Class P4U)

Table 13.11 Inner rings

Unit: μm

Nominal bore diameter d mm	Deviation of mean bore diameter in a single plane Δ_{dmp}		Variation of bore diameter in a single plane V_{dsp}	Perpendicularity of inner ring face with respect to the bore V_{dmp}	Radial runout K_{ia}	Variation of mean bore diameter S_d	Axial runout S_{ia}	Deviation of a single inner ring width Δ_{Bs}		Width variation V_{Bs}
	high	low	max	max	max	max	max	high	low	max
	20	0	-5	2.5	2.5	3	4	4	0	-125
25	0	-5	2.5	2.5	3	4	4	0	-125	2.5
30	0	-5	2.5	2.5	3	4	4	0	-125	2.5
35	0	-5	2.5	2.5	4	4	4	0	-125	3
40	0	-5	2.5	2.5	4	4	4	0	-125	3
90	0	-8	4	4	5	5	5	0	-125	4
100	0	-8	4	4	5	5	5	0	-125	4

Table 13.12 Outer rings

Unit: μm

Nominal outside diameter D mm	Deviation of mean outside diameter in a single plane Δ_{Dmp}		Variation of outside diameter in a single plane V_{Dsp}	Perpendicularity of outer ring outside surface with respect to the face V_{Dmp}	Radial runout K_{ea}	Variation of mean outside diameter S_D	Axial runout S_{ea}	Deviation of a single outer ring width Δ_{Cs}		Width variation V_{Cs}
	high	low	max	max	max	max	max	high	low	max
	68	0	-10	3.5	3.5	5	4	5	0	-250
75	0	-10	3.5	3.5	5	4	5	0	-250	3
80	0	-10	3.5	3.5	5	4	5	0	-250	3
90	0	-10	4	4	6	5	6	0	-250	4
100	0	-10	4	4	6	5	6	0	-250	4
115	0	-10	4	4	6	5	6	0	-250	4
190	0	-15	8	6	10	7	10	0	-250	7
200	0	-15	8	6	10	7	10	0	-250	7

Note: This standard is the NTN standard.

■ Accuracy of HT type

Table 13.13 Inner rings

Nominal bore diameter d	Deviation of mean bore diameter in a single plane						Variation of bore diameter in a single plane						Variation of mean bore diameter			Inner ring radial runout								
	Δ_{dmp}						V_{dsp}						V_{dmp}			K_{ia}								
	mm over incl.		Class 5 high low		Class 4 ¹⁾ high low		Class 2 ¹⁾ high low		Diameter series 9		Diameter series 0, 2		Class 5 max		Class 4 max		Class 2 max		Class 5 max		Class 4 max		Class 2 max	
2.5	10	0	-5	0	-4	0	-2.5	5	4	2.5	4	3	2.5	3	2	1.5	4	2.5	1.5					
10	18	0	-5	0	-4	0	-2.5	5	4	2.5	4	3	2.5	3	2	1.5	4	2.5	1.5					
18	30	0	-6	0	-5	0	-2.5	6	5	2.5	5	4	2.5	3	2.5	1.5	4	3	2.5					
30	50	0	-8	0	-6	0	-2.5	8	6	2.5	6	5	2.5	4	3	1.5	5	4	2.5					

1) The dimensional difference Δ_{ds} of the measured bore diameter applied to Classes 4 and 2 is the same as the tolerance of dimensional difference Δ_{dmp} of the mean bore diameter within a plane. However, the dimensional difference is applied to diameter series 0 and 2 for Class 4, and also to all the diameter series for Class 2.
2) Applies to individual raceway rings manufactured for combined bearing use.

Table 13.14 Outer rings

Nominal outside diameter D	Deviation of mean outside diameter in a single plane						Variation of outside diameter in a single plane						Mean single plane outside diameter deviation			Outer ring radial runout								
	Δ_{Dmp}						V_{Dsp}						V_{Dmp}			K_{ea}								
	mm over incl.		Class 5 high low		Class 4 ³⁾ high low		Class 2 ³⁾ high low		Diameter series 9		Diameter series 0, 2		Class 5 max		Class 4 max		Class 2 max		Class 5 max		Class 4 max		Class 2 max	
18	30	0	-6	0	-5	0	-5	6	5	4	5	4	4	3	2.5	2	6	4	2.5					
30	50	0	-7	0	-6	0	-4	7	6	4	5	5	4	4	3	2	7	5	2.5					
50	80	0	-9	0	-7	0	-4	9	7	4	7	5	4	5	3.5	2	8	5	4					

3) The dimensional difference Δ_{Ds} of the measured outside diameter applied to Classes 4 and 2 is the same as the tolerance of dimensional difference Δ_{Dmp} of the mean outside diameter within a plane. However, the dimensional difference is applied to diameter series 0 and 2 for Class 4, and also to all the diameter series for Class 2.

■ Accuracy of AXN and ARN types

Table 13.15 Inner ring and outer ring

Nominal bearing bore dia. d or nominal bearing outside dia. D	Deviation of mean bore ¹⁾ diameter in a single plane				Thrust inner ring bore ¹⁾ dia. deviation		Deviation of mean outside ²⁾ diameter in a single plane				Deviation of the bearing height		Outer ring width deviation		Radial inner ring ¹⁾ radial runout		
	Δ_{dmp}				Δ_{dis}		Δ_{Dmp}				Δ_{Ts}		Δ_{Cs}		K_{ia}		
	mm over incl.		Class 5 high low		Class 4 high low		Class 5 high low		Class 4 high low		high low		high low		Class 5 max		Class 4 max
18	30	0	-6	0	-5	+61	+40	-	-	-	-			4	3		
30	50	0	-8	0	-6	+75	+50	-	-	-	-			5	4		
50	80	0	-9	0	-7	+90	+60	0	-9	0	-9	0	-370	0	-130	5	4
80	120	-	-	-	-	-	-	0	-10	0	-10			-	-		
120	150	-	-	-	-	-	-	0	-11	0	-11			-	-		

1) Applicable only to dimension d . 2) Applicable only to dimension D .

Unit: μm

Perpendicularity of inner ring face with respect to the bore			Axial runout			Deviation of a single inner ring width				Width variation			
S_d			S_{ia}			Δ_{Bs}				V_{Bs}			
Class 5 max			Class 4 max		Class 2 max	Single bearing		Duplex bearing ²⁾		Class 5 max		Class 4 max	Class 2 max
7	3	1.5	7	3	1.5	0	-40	0	-250	5	2.5	1.5	
7	3	1.5	7	3	1.5	0	-80	0	-250	5	2.5	1.5	
8	4	1.5	8	4	2.5	0	-120	0	-250	5	2.5	1.5	
8	4	1.5	8	4	2.5	0	-120	0	-250	5	3	1.5	

Unit: μm

Perpendicularity of outer ring outside surface with respect to the face			Axial runout			Deviation of a single outer ring width			Width variation			
S_D			S_{ea}			Δ_{Cs}			V_{Cs}			
Class 5 max			Class 4 max		Class 2 max	All classes			Class 5 max		Class 4 max	Class 2 max
8	4	1.5	8	5	2.5	Identical to Δ_{Bs} relative to d of the same bearing			5	2.5	1.5	
8	4	1.5	8	5	2.5				5	2.5	1.5	
8	4	1.5	10	5	4				6	3	1.5	

Unit: μm

Outer ring ²⁾ radial runout		Perpendicularity of outer ring ²⁾ outside surface with respect to the face		Thrust inner ring and ¹⁾ outer ring thickness variation ²⁾	
K_{ea}		S_D		S_{ia}, S_{ea}	
Class 5 max		Class 4 max	Class 5 max		Class 4 max
-	-	-	-	3	2
-	-	-	-	3	2
8	5	8	4	4	3
10	6	9	5	4	3
11	7	10	5	5	4

13.7 Standard preload and axial rigidity

Standard preloads for each type of ball screw support bearings are shown in the dimension tables. In the AXN and ARN types, rigidity is enhanced by tightening the thrust raceways on both sides to supply preload. A bearing that allows preset preload by tightening the bearing raceways to adjust the clearance A between the thrust bearing ring and radial bearing ring (see Fig. 13.19) is also available. Ask NTN for details.

Axial rigidity of the BST type DB duplex arrangement and the AXN type at the standard preload are shown in Fig. 13.20 and Fig. 13.21.

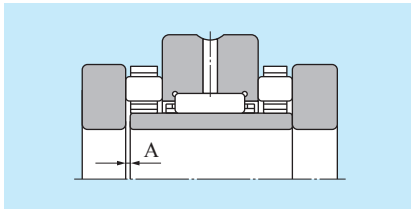

Fig. 13.19

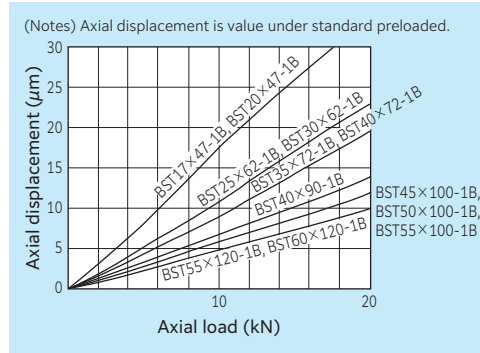

Fig. 13.20 BST type axial rigidity diagram

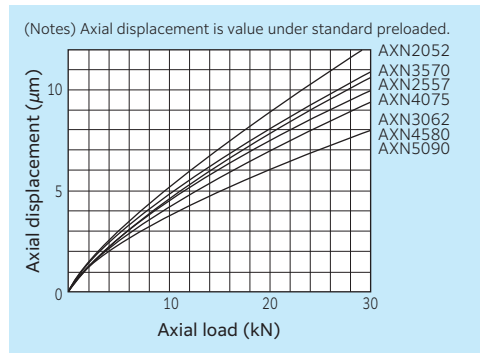

Fig. 13.21 AXN type axial rigidity diagram

13.8 Shaft and housing fits

Recommended fits and tolerances of shaft and housing shoulder squareness are shown in Table 13.16 and Table 13.17.

Table 13.16 Shaft and housing fits

Type code	Types and tolerance class	
	Shaft outside diameter	Housing
BST HT	h5	H6
BSTU		
AXN ARN	j5	J6

Table 13.17 Tolerance of shoulder squareness
Unit: μm

Diameter classification mm		Type code			
over	incl.	BST	BSTU	HT	AXN, ARN
—	30	4	4	4	4
30	80	4	4	4	5
80	120	5	5	—	6
120	180	—	6	—	7
180	200	—	7	—	—

13.9 Applications

The BST type is mainly installed on ball screws of machine tool feed systems, and two to four row arrangements are used in many cases. This type is popular because greased sealed angular contact ball bearings are easy to handle. Bearing combinations include the back-to-back arrangement, where the inner ring is tightened to achieve the required preload, and the front arrangement, where the outer ring is tightened. Examples of bearing arrangement are shown in Fig. 13.22 through Fig. 13.24.

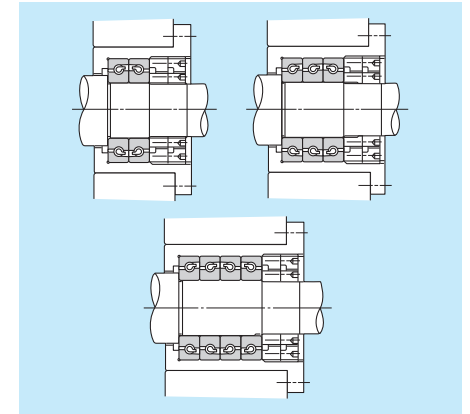

Fig. 13.22

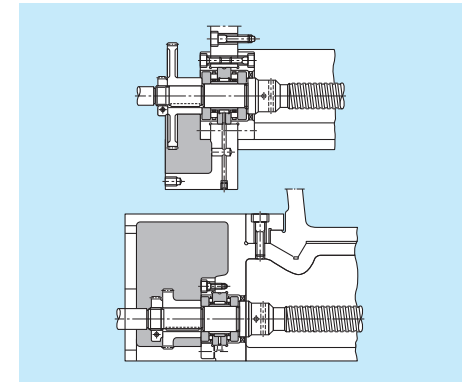

Fig. 13.23

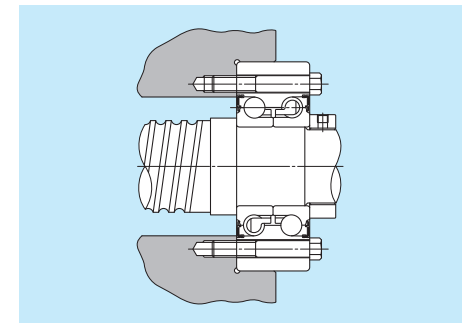

Fig. 13.24

13.10 Starting torque of BST type

Reference starting torque values for BST type bearings are shown in **Table 13.18** and **Table 13.19**.

Table 13.18 Open type BST and 2A-BST types

Part number	Starting torque (reference) N • mm {kgf • cm}			
	DF type DB type	DFT type DBT type	DTFT type DTBT type	DFTT type DBTT type
BST17X47-1B 2A-BST17X47-1B	175 {1.8}	245 {2.5}	355 {3.6}	275 {2.8}
BST20X47-1B 2A-BST20X47-1B	175 {1.8}	245 {2.5}	355 {3.6}	275 {2.8}
BST25X62-1B 2A-BST25X62-1B	305 {3.1}	420 {4.3}	615 {6.3}	470 {4.8}
BST30X62-1B 2A-BST30X62-1B	305 {3.1}	420 {4.3}	615 {6.3}	470 {4.8}
BST35X72-1B 2A-BST35X72-1B	380 {3.9}	510 {5.2}	755 {7.7}	590 {6.0}
BST40X72-1B 2A-BST40X72-1B	380 {3.9}	510 {5.2}	755 {7.7}	590 {6.0}
BST40X90-1B 2A-BST40X90-1B	960 {9.8}	1 305 {13.3}	1 930 {19.7}	1 500 {15.3}
BST45X75-1B 2A-BST45X75-1B	430 {4.4}	580 {5.9}	860 {8.8}	665 {6.8}
BST45X100-1B 2A-BST45X100-1B	1 165 {11.9}	1 580 {16.1}	2 340 {23.9}	1 815 {18.5}
BST50X100-1B 2A-BST50X100-1B	1 165 {11.9}	1 580 {16.1}	2 340 {23.9}	1 815 {18.5}
BST55X100-1B 2A-BST55X100-1B	1 165 {11.9}	1 580 {16.1}	2 340 {23.9}	1 815 {18.5}
BST55X120-1B 2A-BST55X120-1B	1 490 {15.2}	2 010 {20.5}	2 970 {30.3}	2 310 {23.5}
BST60X120-1B 2A-BST60X120-1B	1 490 {15.2}	2 010 {20.5}	2 970 {30.3}	2 310 {23.5}

Table 13.19 Light-contact sealed type BST LXL/L588 and 2A-BST LXL/L588 types

Part number	Starting torque (reference) N • mm {kgf • cm}			
	DF type DB type	DFT type DBT type	DTFT type DTBT type	DFTT type DBTT type
BST17X47-1BLXL 2A-BST17X47-1BLXL	215 {2.2}	295 {3.0}	420 {4.3}	355 {3.4}
BST20X47-1BLXL 2A-BST20X47-1BLXL	215 {2.2}	295 {3.0}	420 {4.3}	355 {3.4}
BST25X62-1BLXL 2A-BST25X62-1BLXL	365 {3.7}	510 {5.2}	745 {7.6}	570 {5.8}
BST30X62-1BLXL 2A-BST30X62-1BLXL	365 {3.7}	510 {5.2}	745 {7.6}	570 {5.8}
BST35X72-1BLXL 2A-BST35X72-1BLXL	460 {4.7}	610 {6.2}	900 {9.2}	705 {7.2}
BST40X72-1BLXL 2A-BST40X72-1BLXL	460 {4.7}	610 {6.2}	900 {9.2}	705 {7.2}
BST40X90-1BLXL 2A-BST40X90-1BLXL	1 155 {11.8}	1 570 {16.0}	2 315 {23.6}	1 805 {18.4}
BST45X75-1BLXL 2A-BST45X75-1BLXL	520 {5.3}	695 {7.1}	1 040 {10.6}	805 {8.2}
BST45X100-1BLXL 2A-BST45X100-1BLXL	1 400 {14.3}	1 890 {19.3}	2 815 {28.7}	2 175 {22.2}
BST50X100-1BLXL 2A-BST50X100-1BLXL	1 400 {14.3}	1 890 {19.3}	2 815 {28.7}	2 175 {22.2}
BST55X100-1BLXL 2A-BST55X100-1BLXL	1 400 {14.3}	1 890 {19.3}	2 815 {28.7}	2 175 {22.2}
BST55X120-1BLXL 2A-BST55X120-1BLXL	1 780 {18.2}	2 410 {24.5}	3 570 {36.4}	2 770 {28.2}
BST60X120-1BLXL 2A-BST60X120-1BLXL	1 780 {18.2}	2 410 {24.5}	3 570 {36.4}	2 770 {28.2}

13.11 Recommended lubrication specifications

BST and HT types ball screw support angular contact ball bearings are generally lubricated with grease (BST LXL type bearings with light-contact seals are packed with grease). AXN and ARN types bearings are generally lubricated with circulated oil.

Oil lubrication

Recommended type of oil

Hydraulic oils or other industrial oils used for lubrication of sliding surfaces with viscosity grade ISO VG 32 or higher are recommended.

Oil quantity

Recommended oil quantity depends on the lubricating method. As a general guideline, the oil flow rate should be 5 to 10 cm³/min. Increase the amount of oil if slippage is expected.

Grease lubrication

Recommended type of grease

Lithium-mineral oil based general purpose grease of which base oil viscosity is high (for example, Alvania Grease S2).

Recommended grease fill

25 % of the capacity shown in the dimensions tables

Recommended grease filling method

Refer to "6. Handling of Bearings, 6.1 Rinsing of bearings and grease filling" in the Technical Data section.

Dynamic equivalent axial load $P_a = XF_r + YF_a$

Number of rows in bearing arrangement	2		3			4				
	1	2	1	2	3	1	2	3	4	
$F_a / F_r \leq 2.17$	X	1.90	—	1.43	2.32	—	1.17	1.90	2.52	—
	Y	0.55	—	0.76	0.35	—	0.88	0.55	0.26	—
$F_a / F_r > 2.17$	X	0.92	0.92	0.92	0.92	0.92	0.92	0.92	0.92	0.92
	Y	1	1	1	1	1	1	1	1	1

Static equivalent axial load

$P_{0a} = F_a + 3.98F_r$

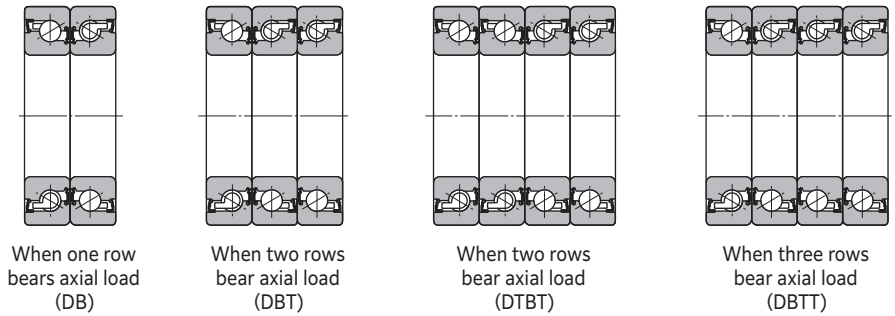
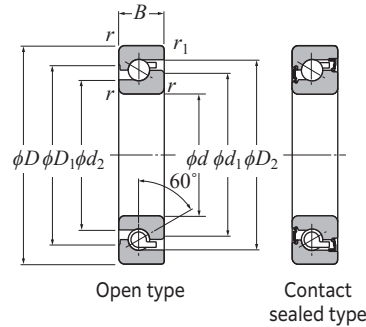

Contact angle 60° d 17–60 mm

Part number	Boundary dimensions						Basic dynamic rated load $C_a^{(2)}$			Basic static rated load $C_{0a}^{(2)}$			Dimensions				Internal free space cm^2 Single-row (approx.)	Allowable axial load $^{(2)}$ (static) kN kgf			Allowable speed	
	mm						kN kgf			kN kgf			mm					1-row 2-row 3-row			grease lubrication	oil lubrication
	d	D	B	$r_{s \min}^{(1)}$	$r_{ls \min}^{(1)}$		1-row	2-row	3-row	1-row	2-row	3-row	d_1	d_2	D_1	D_2		1-row	2-row	3-row	min ⁻¹	
BST17X47-1B	17	47	15	1	0.6	24.3	39.5	52.5	37.5	75.0	113	29.9	27.1	37.1	40.7	4.4	25.7	51.5	77.0	6 500	10 000	
BST17X47-1BLXL						2 470	4 000	5 350	3 850	7 650	11 500						2 620	5 250	7 850		—	
BST20X47-1B	20	47	15	1	0.6	24.3	39.5	52.5	37.5	75.0	113	29.9	27.1	37.1	40.7	4.4	25.7	51.5	77.0	6 500	10 000	
BST20X47-1BLXL						2 470	4 000	5 350	3 850	7 650	11 500						2 620	5 250	7 850		—	
BST25X62-1B	25	62	15	1	0.6	29.2	47.5	63.0	59.0	118	177	44.4	41.6	51.6	55.2	5.9	40.0	80.5	121	4 600	7 000	
BST25X62-1BLXL						2 980	4 850	6 450	6 050	12 100	18 100						4 100	8 200	12 300		—	
BST30X62-1B	30	62	15	1	0.6	29.2	47.5	63.0	59.0	118	177	44.4	41.6	51.6	55.2	5.9	40.0	80.5	121	4 600	7 000	
BST30X62-1BLXL						2 980	4 850	6 450	6 050	12 100	18 100						4 100	8 200	12 300		—	
BST35X72-1B	35	72	15	1	0.6	31.0	50.5	67.0	70.0	140	210	52.4	49.6	59.6	63.2	6.7	47.5	95.0	143	3 900	6 000	
BST35X72-1BLXL						3 150	5 150	6 850	7 150	14 300	21 400						4 850	9 700	14 600		—	
BST40X72-1B	40	72	15	1	0.6	31.0	50.5	67.0	70.0	140	210	52.4	49.6	59.6	63.2	6.7	47.5	95.0	143	3 900	6 000	
BST40X72-1BLXL						3 150	5 150	6 850	7 150	14 300	21 400						4 850	9 700	14 600		—	
BST40X90-1B	40	90	20	1	0.6	58.5	95.0	126	130	261	390	64.8	60.7	75.2	80.4	15	88.5	177	265	3 100	5 400	
BST40X90-1BLXL						6 000	9 700	12 900	13 300	26 600	40 000						9 000	18 000	27 000		—	
BST45X75-1B	45	75	15	1	0.6	32.0	52.0	69.5	77.5	155	232	58.4	55.6	65.6	69.2	7.4	52.5	105	158	3 500	6 000	
BST45X75-1BLXL						3 300	5 350	7 100	7 900	15 800	23 700						5 350	10 700	16 100		—	
BST45X100-1B	45	100	20	1	0.6	62.0	101	134	153	305	460	75.8	71.7	86.2	91.4	18	104	208	315	2 700	4 400	
BST45X100-1BLXL						6 350	10 300	13 700	15 600	31 000	47 000						10 600	21 200	32 000		—	
BST50X100-1B	50	100	20	1	0.6	62.0	101	134	153	305	460	75.8	71.7	86.2	91.4	18	104	208	315	2 700	4 400	
BST50X100-1BLXL						6 350	10 300	13 700	15 600	31 000	47 000						10 600	21 200	32 000		—	
BST55X100-1B	55	100	20	1	0.6	62.0	101	134	153	305	460	75.8	71.7	86.2	91.4	18	104	208	315	2 700	4 400	
BST55X100-1BLXL						6 350	10 300	13 700	15 600	31 000	47 000						10 600	21 200	32 000		—	
BST55X120-1B	55	120	20	1	0.6	66.5	108	143	183	365	550	90.8	86.7	101.2	106.4	21	124	249	375	2 300	3 700	
BST55X120-1BLXL						6 750	11 000	14 600	18 700	37 500	56 000						12 700	25 400	38 000		—	
BST60X120-1B	60	120	20	1	0.6	66.5	108	143	183	365	550	90.8	86.7	101.2	106.4	21	124	249	375	2 300	3 700	
BST60X120-1BLXL						6 750	11 000	14 600	18 700	37 500	56 000						12 700	25 400	38 000		—	

1) Minimum allowable value for corner radius dimension r or r_1 .

2) The number of rows means the number of bearings that bear the axial load.

Ball Screw Support Bearings

Ball Screw Support Bearings

Dynamic equivalent axial load $P_a = XF_r + YF_a$

Number of rows in bearing arrangement	2		3			4				
Number of rows subjected to axial load	1	2	1	2	3	1	2	3	4	
$F_a / F_r \leq 2.17$	X	1.90	—	1.43	2.32	—	1.17	1.90	2.52	—
	Y	0.55	—	0.76	0.35	—	0.88	0.55	0.26	—
$F_a / F_r > 2.17$	X	0.92	0.92	0.92	0.92	0.92	0.92	0.92	0.92	0.92
	Y	1	1	1	1	1	1	1	1	1

Static equivalent axial load

$P_{0a} = F_a + 3.98F_r$

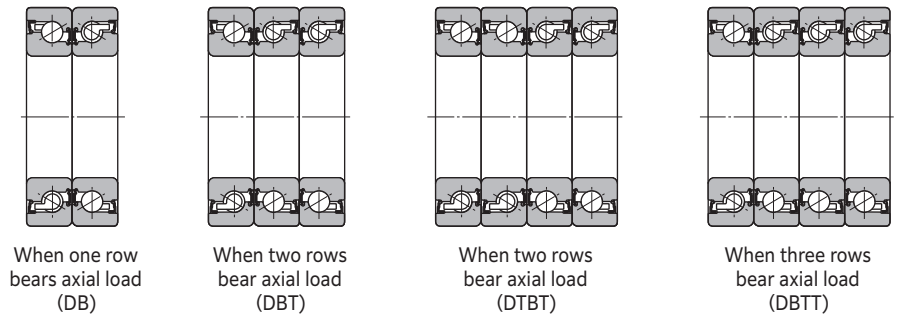
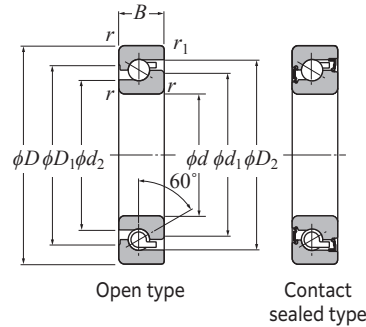

Contact angle 60° **d** 17–60 mm

Part number	Boundary dimensions					Basic dynamic rated load $C_a^{(2)}$			Basic static rated load $C_{0a}^{(2)}$			Dimensions				Internal free space cm^2 Single-row (approx.)	Allowable axial load $^{(2)}$ (static) kN kgf			Allowable speed	
	mm					kN kgf			kN kgf			mm					1-row 2-row 3-row			grease lubrication	oil lubrication
	d	D	B	$r_{s \min}^{(1)}$	$r_{is \min}^{(1)}$	1-row	2-row	3-row	1-row	2-row	3-row	d_1	d_2	D_1	D_2		1-row	2-row	3-row	min ⁻¹	
2A-BST17X47-1B	17	47	15	1	0.6	24.3	39.5	52.5	37.5	75.0	113	29.9	27.1	37.1	40.7	4.4	25.7	51.5	77.0	6 500	10 000
2A-BST17X47-1BLXL						2 470	4 000	5 350	3 850	7 650	11 500						2 620	5 250	7 850		—
2A-BST20X47-1B	20	47	15	1	0.6	24.3	39.5	52.5	37.5	75.0	113	29.9	27.1	37.1	40.7	4.4	25.7	51.5	77.0	6 500	10 000
2A-BST20X47-1BLXL						2 470	4 000	5 350	3 850	7 650	11 500						2 620	5 250	7 850		—
2A-BST25X62-1B	25	62	15	1	0.6	29.2	47.5	63.0	59.0	118	177	44.4	41.6	51.6	55.2	5.9	40.0	80.5	121	4 600	7 000
2A-BST25X62-1BLXL						2 980	4 850	6 450	6 050	12 100	18 100						4 100	8 200	12 300		—
2A-BST30X62-1B	30	62	15	1	0.6	29.2	47.5	63.0	59.0	118	177	44.4	41.6	51.6	55.2	5.9	40.0	80.5	121	4 600	7 000
2A-BST30X62-1BLXL						2 980	4 850	6 450	6 050	12 100	18 100						4 100	8 200	12 300		—
2A-BST35X72-1B	35	72	15	1	0.6	31.0	50.5	67.0	70.0	140	210	52.4	49.6	59.6	63.2	6.7	47.5	95.0	143	3 900	6 000
2A-BST35X72-1BLXL						3 150	5 150	6 850	7 150	14 300	21 400						4 850	9 700	14 600		—
2A-BST40X72-1B	40	72	15	1	0.6	31.0	50.5	67.0	70.0	140	210	52.4	49.6	59.6	63.2	6.7	47.5	95.0	143	3 900	6 000
2A-BST40X72-1BLXL						3 150	5 150	6 850	7 150	14 300	21 400						4 850	9 700	14 600		—
2A-BST40X90-1B	40	90	20	1	0.6	58.5	95.0	126	130	261	390	64.8	60.7	75.2	80.4	15	88.5	177	265	3 100	5 400
2A-BST40X90-1BLXL						6 000	9 700	12 900	13 300	26 600	40 000						9 000	18 000	27 000		—
2A-BST45X75-1B	45	75	15	1	0.6	32.0	52.0	69.5	77.5	155	232	58.4	55.6	65.6	69.2	7.4	52.5	105	158	3 500	6 000
2A-BST45X75-1BLXL						3 300	5 350	7 100	7 900	15 800	23 700						5 350	10 700	16 100		—
2A-BST45X100-1B	45	100	20	1	0.6	62.0	101	134	153	305	460	75.8	71.7	86.2	91.4	18	104	208	315	2 700	4 400
2A-BST45X100-1BLXL						6 350	10 300	13 700	15 600	31 000	47 000						10 600	21 200	32 000		—
2A-BST50X100-1B	50	100	20	1	0.6	62.0	101	134	153	305	460	75.8	71.7	86.2	91.4	18	104	208	315	2 700	4 400
2A-BST50X100-1BLXL						6 350	10 300	13 700	15 600	31 000	47 000						10 600	21 200	32 000		—
2A-BST55X100-1B	55	100	20	1	0.6	62.0	101	134	153	305	460	75.8	71.7	86.2	91.4	18	104	208	315	2 700	4 400
2A-BST55X100-1BLXL						6 350	10 300	13 700	15 600	31 000	47 000						10 600	21 200	32 000		—
2A-BST55X120-1B	55	120	20	1	0.6	66.5	108	143	183	365	550	90.8	86.7	101.2	106.4	21	124	249	375	2 300	3 700
2A-BST55X120-1BLXL						6 750	11 000	14 600	18 700	37 500	56 000						12 700	25 400	38 000		—
2A-BST60X120-1B	60	120	20	1	0.6	66.5	108	143	183	365	550	90.8	86.7	101.2	106.4	21	124	249	375	2 300	3 700
2A-BST60X120-1BLXL						6 750	11 000	14 600	18 700	37 500	56 000						12 700	25 400	38 000		—

1) Minimum allowable value for corner radius dimension r or r_1 .

2) The number of rows means the number of bearings that bear the axial load.

Ball Screw Support Bearings

Ball Screw Support Bearings

ULTAGE Angular contact thrust ball bearings **BST type, 2A-BST type**
Preload and axial rigidity

Contact angle 60° d 17–60 mm

Part number	Standard preload: -1B											
	Two-row (DF/DB types)				Three-row (DFT/DBT types)				Four-row (DTFT/DTBT types)			
	Preload		Axial rigidity		Preload		Axial rigidity		Preload		Axial rigidity	
	N	kgf	N/μm	kgf/μm	N	kgf	N/μm	kgf/μm	N	kgf	N/μm	kgf/μm
BST17X47 2A-BST17X47	2 060	210	635	65	2 840	290	930	95	4 100	420	1 270	130
BST20X47 2A-BST20X47	2 060	210	635	65	2 840	290	930	95	4 100	420	1 270	130
BST25X62 2A-BST25X62	3 250	330	980	100	4 400	450	1 370	140	6 450	660	1 960	200
BST30X62 2A-BST30X62	3 250	330	980	100	4 400	450	1 370	140	6 450	660	1 960	200
BST35X72 2A-BST35X72	3 800	390	1 130	115	5 200	530	1 620	165	7 650	780	2 260	230
BST40X72 2A-BST40X72	3 800	390	1 130	115	5 200	530	1 620	165	7 650	780	2 260	230
BST40X90 2A-BST40X90	7 050	720	1 470	150	9 600	980	2 110	215	14 100	1 440	2 940	300
BST45X75 2A-BST45X75	4 200	430	1 230	125	5 700	580	1 770	180	8 450	860	2 500	255
BST45X100 2A-BST45X100	8 250	840	1 720	175	11 200	1 140	2 450	250	16 500	1 680	3 450	350
BST50X100 2A-BST50X100	8 250	840	1 720	175	11 200	1 140	2 450	250	16 500	1 680	3 450	350
BST55X100 2A-BST55X100	8 250	840	1 720	175	11 200	1 140	2 450	250	16 500	1 680	3 450	350
BST55X120 2A-BST55X120	9 900	1 010	2 010	205	13 400	1 370	2 890	295	19 800	2 020	4 050	415
BST60X120 2A-BST60X120	9 900	1 010	2 010	205	13 400	1 370	2 890	295	19 800	2 020	4 050	415

Part number	Light preload: -11B											
	Two-row (DF/DB types)				Three-row (DFT/DBT types)				Four-row (DTFT/DTBT types)			
	Preload		Axial rigidity		Preload		Axial rigidity		Preload		Axial rigidity	
	N	kgf	N/μm	kgf/μm	N	kgf	N/μm	kgf/μm	N	kgf	N/μm	kgf/μm
BST17X47 2A-BST17X47	1 000	102	490	50	1 370	140	735	75	1 960	200	980	100
BST20X47 2A-BST20X47	1 000	102	490	50	1 370	140	735	75	1 960	200	980	100
BST25X62 2A-BST25X62	1 470	150	735	75	1 960	200	1 080	110	2 940	300	1 470	150
BST30X62 2A-BST30X62	1 560	159	735	75	2 160	220	1 080	110	3 150	320	1 470	150
BST35X72 2A-BST35X72	1 760	180	885	90	2 350	240	1 270	130	3 550	360	1 770	180
BST40X72 2A-BST40X72	1 860	190	885	90	2 550	260	1 270	130	3 700	380	1 770	180
BST40X90 2A-BST40X90	2 370	240	980	100	3 230	330	1 470	150	4 700	480	2 060	210
BST45X75 2A-BST45X75	2 000	200	980	100	2 650	270	1 370	140	3 900	400	1 960	200
BST45X100 2A-BST45X100	2 880	290	1 180	120	3 800	390	1 770	180	5 700	580	2 450	250
BST50X100 2A-BST50X100	3 010	310	1 180	120	4 100	420	1 770	180	6 100	620	2 450	250
BST55X100 2A-BST55X100	3 010	310	1 180	120	4 100	420	1 770	180	6 100	620	2 450	250
BST55X120 2A-BST55X120	3 520	360	1 370	140	4 800	490	2 060	210	7 050	720	2 840	290
BST60X120 2A-BST60X120	3 520	360	1 370	140	4 800	490	2 060	210	7 050	720	2 840	290

NOTE: 1. Preloads listed are indicative of bearing combination specified.
2. The axial rigidity indicated is in the axial direction under the specified preload.

ULTRAGE Double-row thrust angular contact ball bearing unit
BSTU LLX type

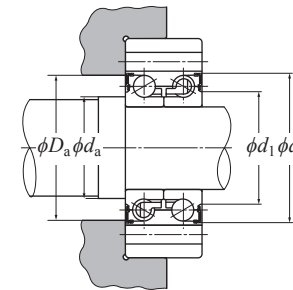
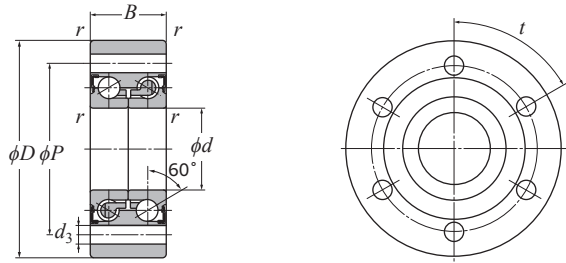

Dynamic equivalent radial load
 $P_a = XF_r + YF_a$

e	$F_a/F_r \leq e$		$F_a/F_r > e$	
	X	Y	X	Y
2.17	1.90	0.55	0.92	1

Static equivalent radial load
 $P_{0a} = F_a + 3.98 F_r$

Contact angle 60° d 20–100 mm

Part number	Boundary dimensions						Basic load ratings				Allowable axial load kN	Allowable speed min ⁻¹ grease lubrication	Reference dimensions		Abutment and fillet dimensions		Outer ring mounting bolt		Preload		Mass kg	Bearing friction torque N·m (approx.)	Axial rigidity N/μm	Moment rigidity N·m/mrad	Inertia of inner ring kg·cm ²	Part number	
	mm						dynamic kN	static kgf	dynamic kgf	static kgf			d ₁	d ₂	D _a max	d _a min	Screws	Quantity × t	N	kgf							
	d	D	B	r _{s min} ¹⁾	P	d ₃	C _a	C _{0a}	C _a	C _{0a}									(static)	(static)							
BSTU2068LLX	20	68	28	0.6	53	6.8	31.0	48.0	3 200	4 900	24.0	2 450	6 000	30.1	43	42	26	M6	4×90°	2 100	215	0.60	0.2	675	150	0.25	BSTU2068LLX
BSTU2575LLX	25	75	28	0.6	58	6.8	34.0	58.0	3 450	5 950	28.5	2 910	5 000	36.1	49	48	32	M6	4×90°	2 400	245	0.72	0.3	790	230	0.45	BSTU2575LLX
BSTU3080LLX	30	80	28	0.6	63	6.8	36.5	68.5	3 700	6 950	33.0	3 350	4 500	41.1	54	53	37	M6	6×60°	2 700	275	0.78	0.3	900	315	0.68	BSTU3080LLX
BSTU30100LLX	30	100	38	0.6	80	8.8	73.5	121	7 500	12 400	61.5	6 250	4 000	47.1	65	64	39	M8	8×45°	4 800	490	1.71	0.8	1 040	500	1.99	BSTU30100LLX
BSTU40100LLX	40	100	34	0.6	80	8.8	52.0	106	5 300	10 800	50.5	5 150	3 500	54.1	68.9	68	49	M8	4×90°	3 200	325	1.46	0.4	1 050	610	2.16	BSTU40100LLX
BSTU40115LLX	40	115	46	0.6	94	8.8	89.0	167	9 050	17 000	82.5	8 400	3 200	61.1	80.2	80	52	M8	12×30°	5 800	590	2.57	1.0	1 260	960	5.52	BSTU40115LLX
BSTU90190LLX	90	190	55	0.6	165	11	158	415	16 100	42 000	195	19 900	1 700	116.1	138.7	137	104	M10	8×45°	8 200	835	7.95	1.5	2 010	4 700	60.0	BSTU90190LLX
BSTU100200LLX	100	200	55	0.6	175	11	160	435	16 300	44 500	205	20 900	1 500	128.1	150.7	150	116	M10	8×45°	8 800	895	8.47	1.7	2 130	5 800	83.8	BSTU100200LLX

1) Minimum allowable value for corner radius dimension r.

ULTAGE Double-row thrust angular contact ball bearing unit
BSTU LLX D2 type

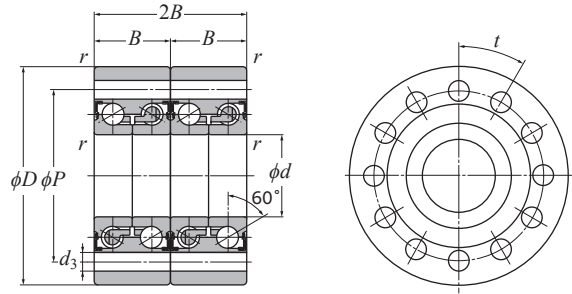

Contact angle 60° d 20–40 mm

Part number	Boundary dimensions						Basic load ratings				Allowable axial load		Allowable speed	Reference dimensions		Abutment and fillet dimensions		Outer ring mounting bolt		Preload		Mass	Bearing friction torque	Axial rigidity	Moment rigidity	Inertia of inner ring	Part number
	d	D	$2B$	$r_{s\min}^1$	P	d_3	C_a	C_{0a}	C_a	C_{0a}	(static)	kgf		d_1	d_2	D_a max	d_a min	Screws	Quantity × t	N	kgf						
BSTU2068LLXD2	20	68	56	0.6	53	6.8	50.5	96.0	5 150	9 800	48.0	4 900	6 000	30.1	43	42	26	M6	8×45°	4 200	430	1.20	0.5	1 350	340	0.50	BSTU2068LLXD2
BSTU2575LLXD2	25	75	56	0.6	58	6.8	55.0	116	5 600	11 900	57.0	5 820	5 000	36.1	49	48	32	M6	8×45°	4 800	490	1.44	0.5	1 580	510	0.90	BSTU2575LLXD2
BSTU3080LLXD2	30	80	56	0.6	63	6.8	59.0	137	6 000	13 900	65.0	6 700	4 500	41.1	54	53	37	M6	12×30°	5 400	550	1.56	0.6	1 800	690	1.36	BSTU3080LLXD2
BSTU40100LLXD2	40	100	68	0.6	80	8.8	84.0	212	8 600	21 600	101	10 300	3 500	54.1	68.9	68	49	M8	8×45°	6 350	650	2.92	0.8	2 100	1 310	4.32	BSTU40100LLXD2
BSTU40115LLXD2	40	115	92	0.6	94	8.8	144	335	14 700	34 000	165	16 800	3 200	61.1	80.2	80	52	M8	12×30°	11 600	1 180	5.14	2.0	2 520	2 150	11.0	BSTU40115LLXD2

1) Minimum allowable value for corner radius dimension r .

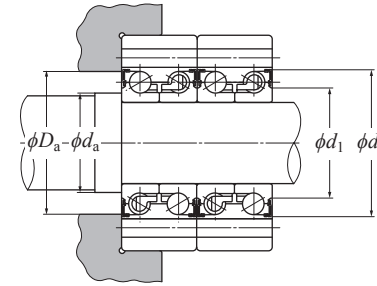

Dynamic equivalent radial load
 $P_a = XF_r + YF_a$

e	$F_a/F_r \leq e$		$F_a/F_r > e$	
	X	Y	X	Y
2.17	—	—	0.92	1

Static equivalent radial load
 $P_{0a} = F_a + 3.98 F_r$

Duplex angular contact ball bearings HT type

Dynamic equivalent axial load $P_a = XF_r + YF_a$

Number of rows in bearing arrangement	2		3			4				
	1	2	1	2	3	1	2	3	4	
$F_a / F_r \leq 0.80$	X	0.81	—	0.61	0.99	—	0.50	0.81	1.07	—
	Y	0.63	—	0.88	0.40	—	1.02	0.63	0.30	—
$F_a / F_r > 0.80$	X	0.51	0.51	0.51	0.51	0.51	0.51	0.51	0.51	0.51
	Y	1	1	1	1	1	1	1	1	1

Static equivalent axial load

$P_{0a} = 1.52F_r + F_a$

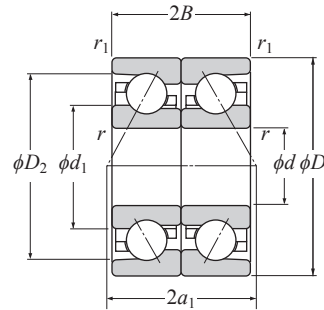

Back-to-back (DB)
Drawings 1

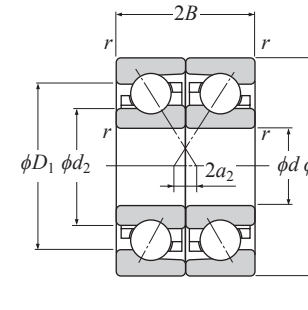

Face-to-face (DF)
Drawings 1

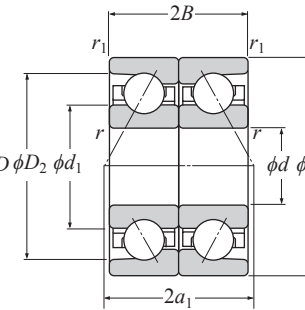

Back-to-back (DB)
Drawings 2

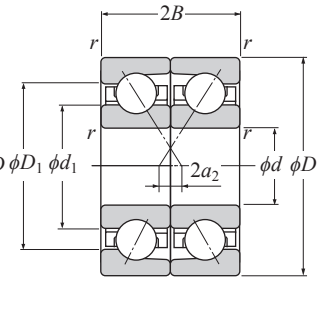

Face-to-face (DF)
Drawings 2

Contact angle 30° d 6–40 mm

Part number	Boundary dimensions		Basic load ratings				Dimensions				Load center	Drawing number	Allowable axial load ²⁾				Medium preload (GM)				Heavy preload (GH)																			
	Back-to-back (DB)	Face-to-face (DF)	mm		dynamic kN	static kgf	mm		DB	DF			(static) kN kgf		Preload ³⁾		Axial rigidity ⁴⁾		Starting torque		Preload ³⁾		Axial rigidity ⁴⁾		Starting torque															
	d	D	$2B$	$r_{s \min}^{-1}$	$r_{ls \min}^{-1}$	C_a	C_{0a}	C_a	C_{0a}	d_1	d_2	D_1	D_2	a_1	a_2	1-row	2-row	N	kgf	N/ μ m	kgf/ μ m	N-mm (approx.)	N	kgf	N/ μ m	kgf/ μ m	N-mm (approx.)													
79M6ADB 79M6ADF	6	15	10	0.2	0.1	2.27	2.09	232	213	10.0	8.4	11.1	12.9	11.1	1.1	1	1.83	187	3.66	374	20	2	27	3	37	3.8	55	5.6	0.4	0.6	39	4	53	5.5	48	4.9	67	6.8	1.0	1.1
70M6DB 70M6DF	6	17	12	0.3	0.15	2.96	2.41	300	246	9.8	—	13.2	14.8	12.7	0.7	2	1.01	103	2.02	206	29	3	39	4	37	3.8	53	5.4	0.8	1.0	49	5	67	7	45	4.6	65	6.6	1.5	2.2
79M8ADB 79M8ADF	8	19	12	0.3	0.15	3.25	3.25	330	335	12.6	10.9	14.4	16.4	13.9	1.9	1	2.14	219	4.28	438	29	3	39	4	48	4.9	68	6.9	0.7	0.9	59	6	80	8	62	6.3	88	9.0	1.7	2.3
70M8DB 70M8DF	8	22	14	0.3	0.15	4.85	4.40	495	445	12.8	—	17.2	19.1	15.8	1.8	2	1.53	156	3.06	312	49	5	67	7	52	5.3	75	7.6	1.6	2.2	98	10	133	14	67	6.9	97	9.9	4.0	5.7
7000HTDB 7000HTDF	10	26	16	0.3	0.15	6.75	6.30	690	640	15.5	—	20.3	22.7	18.4	2.4	2	3.10	314	6.20	628	147	15	200	20	82	8.4	116	11.8	7.4	9.7	196	20	266	27	92	9.4	131	13.3	11.0	14.7
7001HTDB 7001HTDF	12	28	16	0.3	0.15	7.35	7.45	750	760	18.1	—	22.9	25.4	20.0	4.0	2	3.25	331	6.50	662	147	15	200	20	88	9.0	125	12.7	7.2	9.5	196	20	266	27	99	10.1	140	14.3	10.8	14.4
7002HTDB 7002HTDF	15	32	18	0.3	0.15	8.45	9.50	860	970	21.1	—	25.9	28.4	22.7	4.7	2	4.00	407	8.00	814	147	15	200	20	100	10.2	141	14.4	6.9	9.1	294	30	400	41	131	13.4	187	19.1	18.1	24.7
7203HTDB 7203HTDF	17	40	24	0.6	0.3	15.2	16.4	1550	1670	25.0	—	32.0	36.2	28.8	4.8	2	5.85	595	11.7	1190	294	30	400	41	126	12.9	180	18.4	20.5	27.9	390	40	530	54	141	14.4	201	20.5	30.5	40.8
7004HTDB 7004HTDF	20	42	24	0.6	0.3	14.1	17.0	1440	1730	28.4	—	34.7	38.1	30.3	6.3	2	7.55	770	15.1	1540	294	30	400	41	139	14.2	199	20.3	19.3	26.2	490	50	665	68	170	17.3	242	24.7	39.3	53.1
7204HTDB 7204HTDF	20	47	28	1.0	0.6	19.8	23.1	2020	2360	30.5	—	38.6	42.7	34.1	6.1	2	9.50	970	19.0	1940	490	50	665	68	168	17.2	240	24.5	41.5	56.1	785	80	1070	109	203	20.7	289	29.5	79.7	108
7205HTDB 7205HTDF	25	52	30	1.0	0.6	22.4	28.8	2280	2940	35.0	—	43.0	47.2	37.7	7.7	2	11.5	1170	23.0	2340	490	50	665	68	188	19.2	269	27.4	39.7	53.7	785	80	1070	109	226	23.1	323	32.9	76.4	104
7206HTDB 7206HTDF	30	62	32	1.0	0.6	31.0	41.5	3150	4200	41.7	—	51.4	56.3	43.1	11.1	2	16.3	1660	32.6	3320	490	50	665	68	197	20.0	281	28.6	41.3	55.8	785	80	1070	109	235	24.0	336	34.2	79.4	108
7207HTDB 7207HTDF	35	72	34	1.1	0.6	41.0	56.0	4200	5750	47.9	—	59.2	64.9	48.2	14.2	2	21.9	2230	43.8	4470	885	90	1200	122	255	26.0	363	37.1	96.4	130	1470	150	2000	204	311	31.7	443	45.2	196	265
7208HTDB 7208HTDF	40	80	36	1.1	0.6	49.0	71.0	5000	7200	54.0	—	66.0	72.2	52.9	16.9	2	27.1	2770	54.2	5540	885	90	1200	122	272	27.8	389	39.6	95.8	129	1470	150	2000	204	331	33.8	473	48.2	195	264

1) Minimum allowable value for corner radius dimension r or r_1 .

2) The number of rows means the number of bearings that bear the axial load.

3) Preloads listed are indicative of bearing combination specified.

4) The axial rigidity indicated is in the axial direction under the specified preload.

Needle roller bearings
with double-direction thrust needle roller bearings AXN type

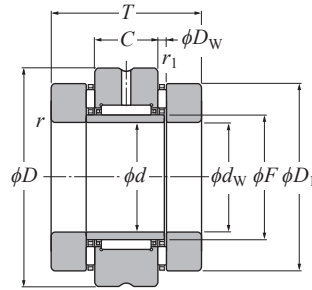

d 20-50 mm

Part number	Boundary dimensions										Basic load ratings				Basic load ratings		Allowable speed		Radial internal clearance		Abutment and fillet dimensions				Preload N	Starting ²⁾ torque N·mm (approx.)	Mass kg (approx.)	Part number		
	mm										dynamic	static	dynamic	static	dynamic	static	grease	oil	min	max	d _a	D _a	r _{as}	r _{1as}						
	d	d _w	D	D ₁ <small>$\begin{matrix} -0.20 \\ -0.50 \end{matrix}$</small>	T	C	F	D _w	r _s min ¹⁾	r _{1s} min ¹⁾	C _r	C _{0r}	C _r	C _{0r}	C _a	C _{0a}	lubrication	lubrication	min	max	min	max	max	max						
AXN2052	20	20 ^{$\begin{matrix} +0.061 \\ +0.040 \end{matrix}$}	52	42	40	16	25	2	0.6	0.6	15.1	22.4	1 540	2 280	14.6	58.0	1 490	5 900	1 800	7 000	10	30	39	46	0.6	0.6	1 300	330	0.40	AXN2052
AXN2557	25	25 ^{$\begin{matrix} +0.061 \\ +0.040 \end{matrix}$}	57	47	44	20	30	2	0.6	0.6	22.1	34.0	2 260	3 500	16.3	69.5	1 660	7 100	1 500	6 000	10	30	44	51	0.6	0.6	1 450	400	0.52	AXN2557
AXN3062	30	30 ^{$\begin{matrix} +0.061 \\ +0.040 \end{matrix}$}	62	52	44	20	35	2	0.6	0.6	24.8	41.5	2 520	4 250	17.8	81.5	1 820	8 300	1 400	5 500	10	40	50	56	0.6	0.6	1 600	550	0.59	AXN3062
AXN3570	35	35 ^{$\begin{matrix} +0.075 \\ +0.050 \end{matrix}$}	70	60	48	20	40	3	1	0.6	26.4	47.0	2 700	4 800	27.4	110	2 790	11 300	1 200	4 700	10	40	56	64	1	0.6	2 450	900	0.80	AXN3570
AXN4075	40	40 ^{$\begin{matrix} +0.075 \\ +0.050 \end{matrix}$}	75	65	48	20	45	3	1	0.6	28.0	52.5	2 860	5 400	29.8	128	3 050	13 100	1 100	4 300	10	40	62	69	1	0.6	2 650	1 050	0.89	AXN4075
AXN4580	45	45 ^{$\begin{matrix} +0.075 \\ +0.050 \end{matrix}$}	80	70	54	25	50	3	1	0.6	38.5	74.5	3 950	7 550	31.5	143	3 250	14 500	1 000	3 900	10	40	67	74	1	0.6	2 800	1 200	1.00	AXN4580
AXN5090	50	50 ^{$\begin{matrix} +0.075 \\ +0.050 \end{matrix}$}	90	78	54	25	55	3	1	0.6	41.0	82.0	4 150	8 400	38.0	186	3 850	19 000	900	3 500	15	50	75	83	1	0.6	3 400	1 600	1.42	AXN5090

1) Minimum allowable value for corner radius dimension r or r₁.
2) Starting torque value relative to the standard preload.

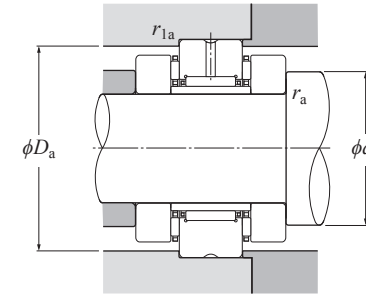

Needle roller bearings with double-direction thrust cylindrical roller bearings ARN type

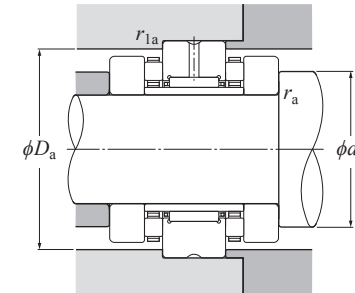
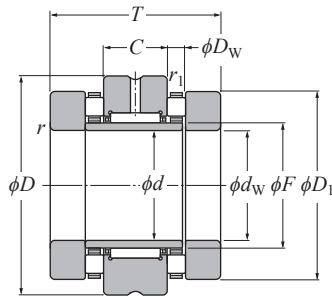

d 20–70 mm

Part number	Boundary dimensions										Basic load ratings				Basic load ratings				Allowable speed		Radial internal clearance		Abutment and fillet dimensions				Preload N	Starting torque ²⁾ N·mm	Mass kg	Part number
	mm										dynamic radial kN	static radial kN	dynamic radial kgf	static radial kgf	grease lubrication min ⁻¹	oil lubrication min ⁻¹	min	max	da min	Da max	ras max	r1as max								
	d	d _w	D	D ₁	T	C	F	D _w	r _{s min} ¹⁾	r _{1s min} ¹⁾													C _r	C _{0r}	C _a	C _{0a}				
ARN2052T2	20	20	52	42	46	16	25	5	0.6	0.6	15.1	22.4	1 540	2 280	27.3	68.0	2 790	6 900	1 800	7 000	10	30	39	46	0.6	0.6	2 500	430	0.44	ARN2052T2
ARN2062	20	20	62	52	60	20	30	7.5	1	0.6	22.1	34.0	2 260	3 500	53.5	129	5 450	13 100	1 500	6 000	10	30	48	56	1	0.6	4 950	1 150	0.91	ARN2062
ARN2557T2	25	25	57	47	50	20	30	5	0.6	0.6	22.1	34.0	2 260	3 500	27.8	72.5	2 840	7 400	1 500	6 000	10	30	44	51	0.6	0.6	2 600	500	0.56	ARN2557T2
ARN2572	25	25	72	62	60	20	35	7.5	1	0.6	24.8	41.5	2 520	4 250	54.5	139	5 550	14 200	1 200	4 900	10	40	56	66	1	0.6	5 050	1 400	1.22	ARN2572
ARN3062T2	30	30	62	52	50	20	35	5	0.6	0.6	24.8	41.5	2 520	4 250	31.0	87.0	3 150	8 900	1 400	5 500	10	40	49	56	0.6	0.6	2 900	650	0.63	ARN3062T2
ARN3080	30	30	80	68	66	20	40	9	1	0.6	26.4	47.0	2 700	4 800	74.5	190	7 600	19 400	1 100	4 400	10	40	63	73	1	0.6	6 900	2 100	1.54	ARN3080
ARN3570T2	35	35	70	60	54	20	40	6	1	0.6	26.4	47.0	2 700	4 800	43.0	121	4 350	12 400	1 200	4 800	10	40	56	64	1	0.6	3 950	1 050	0.85	ARN3570T2
ARN3585	35	35	85	73	66	20	45	9	1	0.6	28.0	52.5	2 860	5 400	82.0	222	8 350	22 600	1 000	4 100	10	40	68	77	1	0.6	7 600	2 500	1.67	ARN3585
ARN4075T2	40	40	75	65	54	20	45	6	1	0.6	28.0	52.5	2 860	5 400	45.5	135	4 650	13 800	1 100	4 400	10	40	61	69	1	0.6	4 200	1 250	0.93	ARN4075T2
ARN4090	40	40	90	78	75	25	50	9	1	0.6	38.5	74.5	3 950	7 550	85.0	238	8 650	24 200	950	3 800	10	40	73	87	1	0.6	7 850	2 850	2.15	ARN4090
ARN4580T2	45	45	80	70	60	25	50	6	1	0.6	38.5	74.5	3 950	7 550	48.5	150	4 900	15 300	1 000	4 000	10	40	66	74	1	0.6	4 450	1 550	1.16	ARN4580T2
ARN45105	45	45	105	90	82	25	55	11	1	0.6	41.0	82.0	4 150	8 400	121	340	12 300	34 500	850	3 300	15	50	83	96	1	0.6	11 200	4 350	3.16	ARN45105
ARN5090	50	50	90	78	60	25	55	6	1	0.6	41.0	82.0	4 150	8 400	62.5	215	6 350	21 900	900	3 600	15	50	75	83	1	0.6	5 800	2 050	1.48	ARN5090
ARN50110	50	50	110	95	82	25	60	11	1.1	0.6	41.0	85.0	4 200	8 700	125	365	12 800	37 000	800	3 100	15	50	88	101	1	0.6	11 600	4 900	3.38	ARN50110
ARN55115	55	55	115	100	82	25	65	11	1.1	0.6	45.0	98.0	4 550	10 000	130	385	13 200	39 500	750	2 900	15	50	93	106	1	0.6	12 000	5 500	3.61	ARN55115
ARN60120	60	60	120	105	82	25	70	11	1.1	0.6	45.0	91.5	4 600	9 350	134	410	13 700	42 000	700	2 700	15	50	98	111	1	0.6	12 400	6 000	3.81	ARN60120
ARN65125	65	65	125	110	82	25	75	11	1.1	0.6	55.0	104	5 600	10 600	138	435	14 100	44 500	650	2 600	15	50	103	116	1	0.6	12 800	6 500	4.00	ARN65125
ARN70130	70	70	130	115	82	25	80	11	1.1	0.6	57.0	119	5 800	12 200	142	460	14 500	47 000	650	2 500	15	50	106	121	1	0.6	13 200	7 000	4.25	ARN70130

1) Minimum allowable value for corner radius dimension r or r₁.
2) Starting torque value relative to the standard preload.

14. Cam Followers for Pallet Changer

Cam followers are often used on work piece transfer systems (such as pallet changers) of machine tools (such as machining centers) to handle the large loads generated by these systems.

NTN offers various types of cam followers that include a ready-to-install cam follower optimized for pallet changers.

14.1 Structure and features

- The outer ring wall thickness is maximized for resistance to heavy load or impact load.
- Feature a compact design and can be easily mounted by tightening a setscrew.
- The outer ring outside diameter, outer ring width, and stud diameter are identical to the dimensions of NTN's standard cam followers (KR type).
- Because are actuated less frequently, they do not need to be relubricated. The oil hole has been deleted.
- Cost is reduced by removing the grease hole and the thread from the stud.

14.2 Cam follower numbering

The part number for cam followers for pallet changers is same as that of NTN special cam followers.

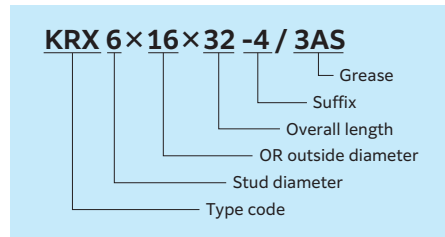

14.3 Accuracy

The accuracy of NTN cam followers for pallet changer is same as that of NTN standard cam followers (JIS Class 0).

14.4 Fits

The NTN pallet changer cam follower has a special stud that is readily secured with a setscrew. As shown example of mounting Fig. 14.2, a setscrew locks the pallet changer cam follower in the axial and circumferential directions.

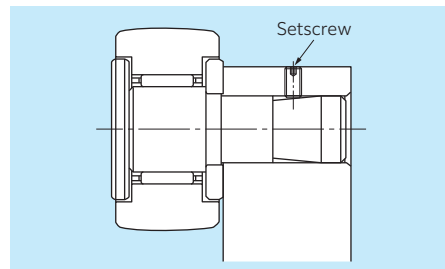

Fig. 14.2 Example of mounting

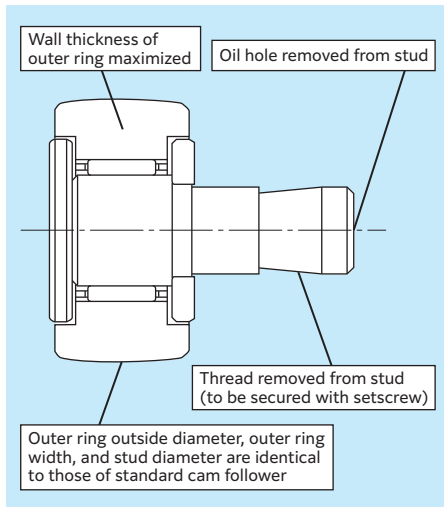

Fig. 14.1 Schematic of NTN pallet changer cam follower

14.5 Radial internal clearance

The radial clearance of NTN cam followers for pallet changers is same as that of NTN standard cam followers (see Table 14.1).

Table 14.1. Radial internal clearance of cam followers Unit: μm

Nominal roller inscribed circle diameter F_w (mm)		Internal clearance	
over	incl.	CN (normal clearance)	
		min	max
3	6	3	17
6	10	5	20
10	18	5	25
18	30	10	30
30	50	10	40

14.6 Lubrication

NTN cam followers for pallet changers are filled with lithium based grease and can be used in a temperature range of -20 to 120 °C (100 °C or less for continuous use).

Under the assumption that the user does not perform relubrication with grease, the standard NTN pallet changer cam follower does not have an oil hole for relubrication (If necessary, the cam follower can be provided with an oil hole or a hole for mounting a grease nipple).

Upon request, NTN can also provide cam followers with a synthetic rubber seal.

Lubrication between the outside surface of bearing and track is also necessary. Failure to properly lubricate the outside surface of the cam follower could lead to premature wear of the bearing.

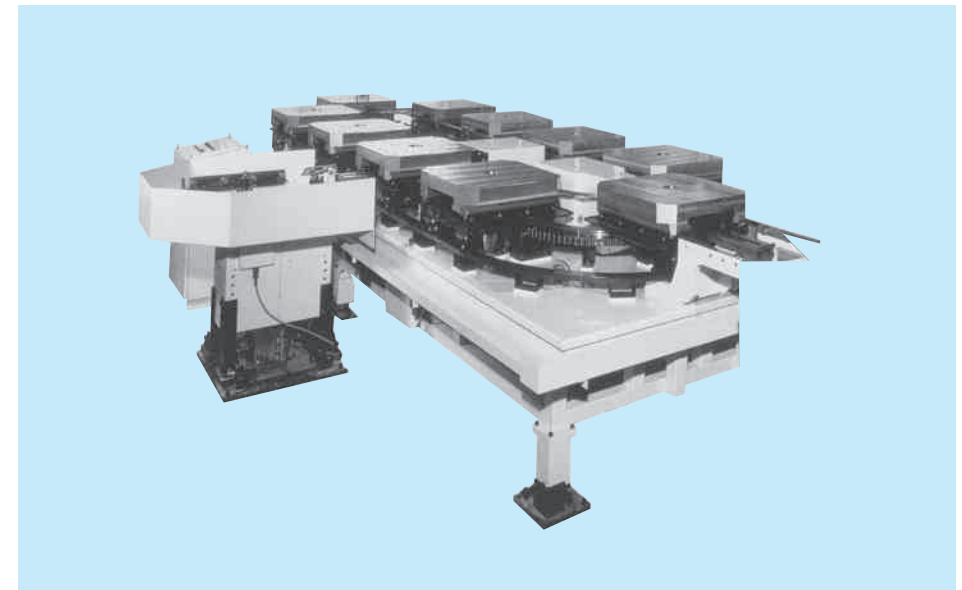

Example application of NTN cam followers for pallet changer (Photo: courtesy of Tsudakoma Corporation)

Cam followers for pallet changers
Sealed KRX type

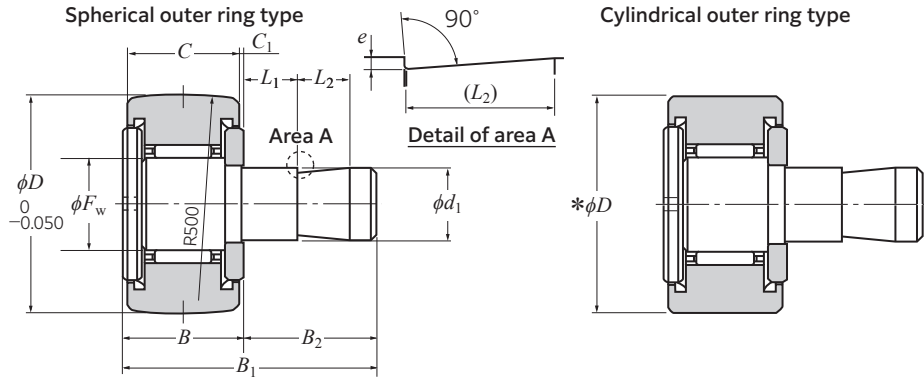

d₁ 6-20 mm

Cam follower number		Dimensions mm		Dimensions mm					Basic load ratings		Track load capacity		Reference dimensions						
Spherical outer ring	Cylindrical outer ring	d ₁	Tolerance	D	Tolerance* (cylindrical outer ring)				C _T	C _{Or}	spherical outer ring	cylindrical outer ring	mm						
					F _w	B ₁	B	B ₂					C	C ₁	L ₁	L ₂	e	n	h
KRX 6×16×32-4/3AS	KRX 6×16×32-2/3AS	6	⁰ / _{-0.012}	16	⁰ / _{-0.008}	8	32	12	20	4 050	4 200	1 080	3 400	28	16	M6 ×1	8	—	3
KRX 8×19×32-9/3AS	KRX 8×19×32-7/3AS	8	⁰ / _{-0.015}	19	⁰ / _{-0.009}	10	32	12	20	4 750	5 400	1 380	4 050	32	20	M8 ×1.25	10	—	4
KRX10×22×33-3/3AS	KRX10×22×33-1/3AS	10	⁰ / _{-0.015}	22	⁰ / _{-0.009}	12	33	13	20	5 300	6 650	1 690	5 150	36	23	M10×1.25	12	4	4
KRX10×26×33-4/3AS	KRX10×26×33-2/3AS	10	⁰ / _{-0.015}	26	⁰ / _{-0.009}	12	33	13	20	5 300	6 650	2 120	6 100	36	23	M10×1.25	12	4	4
KRX12×30×35-3/3AS	KRX12×30×35/3AS	12	⁰ / _{-0.018}	30	⁰ / _{-0.009}	15	35	15	20	7 850	9 650	2 620	7 700	40	25	M12×1.5	13	6	6
KRX12×32×35-3/3AS	KRX12×32×35-1/3AS	12	⁰ / _{-0.018}	32	⁰ / _{-0.011}	15	35	15	20	7 850	9 650	2 860	8 200	40	25	M12×1.5	13	6	6
KRX16×35×44.5-1/3AS	KRX16×35×44.5-3/3AS	16	⁰ / _{-0.018}	35	⁰ / _{-0.011}	18	44.5	19.5	25	12 200	17 900	3 200	11 900	52	32.5	M16×1.5	17	6	6
KRX18×40×46.5-6/3AS	KRX18×40×46.5-4/3AS	18	⁰ / _{-0.018}	40	⁰ / _{-0.011}	22	46.5	21.5	25	14 000	22 800	3 850	14 500	58	36.5	M18×1.5	19	6	6
KRX20×47×50.5-1/3AS	KRX20×47×50.5-3/3AS	20	⁰ / _{-0.021}	47	⁰ / _{-0.011}	25	50.5	25.5	25	20 700	33 500	4 700	21 000	66	40.5	M20×1.5	21	8	8
KRX20×52×50.5-3/3AS	KRX20×52×50.5-1/3AS	20	⁰ / _{-0.021}	52	⁰ / _{-0.013}	25	50.5	25.5	25	2 110	3 450	565	2 370	66	40.5	M20×1.5	21	8	8

(Reference) Standard cam follower KR·H type (w/ hex socket)

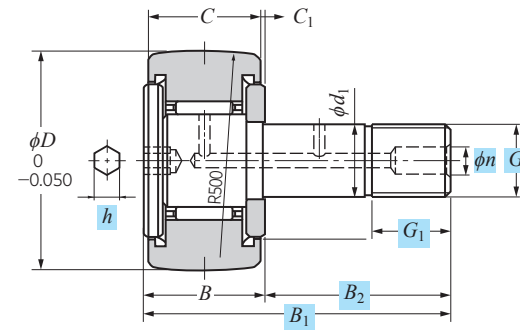

The dimensions of standard cam followers (marked with in the diagram above) are different from those of NTN pallet changer cam followers. Please see the reference dimensions in the table below.

* The cam followers in the table above have seals. However, upon request, NTN will offer a cam followers without seals.

Appendix table-1: Boundary dimensions of radial bearings (Tapered roller bearings not included)-5 Unit: mm

Table with columns: Single row radial ball bearings, Double row radial ball bearings, Cylindrical roller bearings, Needle roller bearings, Spherical roller bearings. Sub-headers for Nominal bearing bore diameter d, Dimension series, Nominal bearing outside diameter D, and Nominal width B.

Appendix table-1: Boundary dimensions of radial bearings (Tapered roller bearings not included)-6 Unit: mm

Table with columns: Single row radial ball bearings, Double row radial ball bearings, Cylindrical roller bearings, Needle roller bearings, Spherical roller bearings. Sub-headers for Nominal bearing bore diameter d, Diameter series 3, Diameter series 4, and Chamfer dimension.

Appendix table-2: Comparison table of SI and CGS series gravity units-1

Unit system	Quantity	Length L	Mass M	Time T	Acceleration	Force	Stress	Pressure	Energy
SI		m	kg	s	m/s ²	N	Pa	Pa	J
CGS system		cm	g	s	Gal	dyn	dyn/cm ²	dyn/cm ²	erg
Gravitation system		m	kgf·s ² /m	s	m/s ²	kgf	kgf/m ²	kgf/m ²	kgf·m

Appendix table-3: SI-customary unit conversion table-1

Quantity	Unit designation	Code	Conversion rate to SI	SI unit designation	Code
Angle	Degree	°	$\pi/180$	Radian	rad
	Minute	'	$\pi/10\ 800$		
	Second	"(sec)	$\pi/648\ 000$		
Length	Meter	m	1	Meter	m
	Micron	μ	10^{-6}		
	Angstrom	Å	10^{-10}		
Area	Square meter	m ²	1	Square meter	m ²
	Are	a	10^2		
	Hectare	ha	10^4		
Volume	Cubic meter	m ³	1	Cubic meter	m ³
	Liter	ℓ.L	10^{-3}		
Mass	Kilogram	kg	1	Kilogram	kg
	Ton	t	10^3		
	Kilogram force / square second per meter	kgf·s ² /m	9.806 65		
Time	Second	s	1	Second	s
	Minute	min	60		
	Hour	h	3 600		
	Day	d	86 400		
Speed	Meters per second	m/s	1	Meters per second	m/s
	Knot	kn	$1\ 852/3\ 600$		
Frequency and vibration	Cycle	s ⁻¹ (pps)	1	Hertz	Hz
Revolutions (rotational speed)	Revolutions per minute (rpm)	rpm (r/min)	1/60	Per second	s ⁻¹
Angular velocity	Radians per second	rad/s	1	Radians per second	rad/s
Acceleration	Meters per square second	m/s ²	1	Radians per second	m/s ²
	G	G	9.806 65		
Force	Kilogram force	kgf	9.806 65	Newton	N
	Ton force	tf	9 806.65		
	Dyne	dyn	10^{-5}		
Force moment	Kilogram force / meter	kgf·m	9.806 65	Newton meter	N·m
Inertia moment	Kilogram force / meter / square second	kgf·m·s ⁻²	9.806 65	Kilogram / square meter	kg·m ²
	Stress	kgf/m ²	9.806 65		
Pressure	Kilogram force per square meter	kgf/m ²	9.806 65	Pascal	Pa
	Meter water column	mH ₂ O	9 806.65		
	Meter of mercury	mHg	$101\ 325/0.76$		
	Torr	Torr	$101\ 325/760$		
	Atmosphere	atm	101 325		
	Bar	bar	10^5		
Energy	Erg	erg	10^{-7}	Joule	J
	IT calorie	cal _{IT}	4.186 8		
	Kilogram force / meter	kgf·m	9.806 65		
	Kilowatt hour	kW·h	3.600×10^6		
	Metric horsepower per hour	PS·h	$2.647\ 79 \times 10^6$		
Power rate and power	Watt	W	1	Watt	W
	Metric horsepower	PS	735.5		
	Kilogram force / meter per second	kgf·m/s	9.806 65		

Appendix table-2: Comparison table of SI and CGS series gravity units-2

Unit system	Quantity	Power rate	Temperature	Viscosity	Dynamic viscosity	Flux	Flux density	Magnetic field strength
SI		W	K	Pa·s	m ² /s	Wb	T	A/m
CGS system		erg/s	°C	P	St	Mx	Gs	Oe
Gravitation system		kgf·m/s	°C	kgf·s/m ²	m ² /s	—	—	—

Appendix table-3: SI-customary unit conversion table-2

Quantity	Unit designation	Code	Conversion rate to SI	SI unit designation	Code
Viscosity	Poise	P	10^{-1}	Pascal second	Pa·s
	Centipoise	cP	10^{-3}		
	Kilogram force / square second per meter	kgf·s/m ²	9.806 65		
Dynamic viscosity	Stoke	St	10^{-4}	Square meter per second	m ² /s
	Centistoke	cSt	10^{-6}		
Temperature	Degree	°C	+273.15	Kelvin	K
Radioactivity	Curie	Ci	3.7×10^{10}	Becquerel	Bq
	Dosage	R	2.58×10^{-4}		
Absorption dosage	Rad	rad	10^{-2}	Gray	Gy
Dosage equivalent	Rem	rem	10^{-2}	Sievert	Sv
Dosage equivalent	Maxwell	Mx	10^{-8}	Weber	Wb
Flux density	Gamma	γ	10^{-9}	Tesla	T
	Gauss	Gs	10^{-4}		
Magnetic field strength	Oersted	Oe	$10^3/4\pi$	Amperes per meter	A/m
Magnetic field strength	Coulomb	C	1	Coulomb	C
Potential difference	Volt	V	1	Volt	V
Electric resistance	Ohm	Ω	1	Ohm	Ω
	Curren	Ampere	1		

Appendix table-4: Tenth power multiples of SI unit

Multiples of unit	Prefix		Multiples of unit	Prefix	
	Designation	Code		Designation	Code
10^{18}	Exa	E	10^{-1}	Deci	d
10^{15}	Peta	P	10^{-2}	Centi	c
10^{12}	Tera	T	10^{-3}	Milli	m
10^9	Giga	G	10^{-6}	Micro	μ
10^6	Mega	M	10^{-9}	Nano	n
10^3	Kilo	k	10^{-12}	Pico	p
10^2	Hecto	h	10^{-15}	Femto	f
10	Deca	da	10^{-18}	Atto	a

Appendix table-5: Dimensional tolerance for shafts

Table with columns for Diameter division mm (mm) and tolerance values for shafts (a13, c12, d6, e6, e13, f5, f6, g5, g6). Tolerances are shown in micrometers (µm) with upper and lower values.

1) Basic tolerance a is not used for the basic size tolerance with respect to the size of 1 mm or below shown in drawings.

Table with columns for Diameter division mm and tolerance values for shafts (j5, js5, j6, js6, j7, k4, k5, k6, m5). Tolerances are shown in micrometers (µm) with upper and lower values.

Unit: µm

Table with columns for Diameter division mm and tolerance values for shafts (h4, h5, h6, h7, h8, h9, h10, h11, h13, js4). Tolerances are shown in micrometers (µm) with upper and lower values.

Unit: µm

Table with columns for Diameter division mm and tolerance values for shafts (m6, n5, n6, p5, p6, r6, r7, Basic tolerance). Tolerances are shown in micrometers (µm) with upper and lower values.

Appendix table-7: Basic tolerance

Unit: μm

Basic dimension mm		IT basic tolerance class									
Over	Incl.	IT1	IT2	IT3	IT4	IT5	IT6	IT7	IT8	IT9	IT10
—	3	0.8	1.2	2	3	4	6	10	14	25	40
3	6	1	1.5	2.5	4	5	8	12	18	30	48
6	10	1	1.5	2.5	4	6	9	15	22	36	58
10	18	1.2	2	3	5	8	11	18	27	43	70
18	30	1.5	2.5	4	6	9	13	21	33	52	84
30	50	1.5	2.5	4	7	11	16	25	39	62	100
50	80	2	3	5	8	13	19	30	46	74	120
80	120	2.5	4	6	10	15	22	35	54	87	140
120	180	3.5	5	8	12	18	25	40	63	100	160
180	250	4.5	7	10	14	20	29	46	72	115	185
250	315	6	8	12	16	23	32	52	81	130	210
315	400	7	9	13	18	25	36	57	89	140	230
400	500	8	10	15	20	27	40	63	97	155	250
500	630	9	11	16	22	30	44	70	110	175	280
630	800	10	13	18	25	35	50	80	125	200	320
800	1 000	11	15	21	29	40	56	90	140	230	360
1 000	1 250	13	18	24	34	46	66	105	165	260	420
1 250	1 600	15	21	29	40	54	78	125	195	310	500
1 600	2 000	18	25	35	48	65	92	150	230	370	600
2 000	2 500	22	30	41	57	77	110	175	280	440	700
2 500	3 150	26	36	50	69	93	135	210	330	540	860

Appendix table-8: Viscosity conversion table

Dynamic viscosit mm ² /s	Saybolt SUS (second)	Redwood R (second)	Engler E (degree)	Dynamic viscosit mm ² /s	Saybolt SUS (second)	Redwood R (second)	Engler E (degree)
2.7	35	32.2	1.18	103	475	419	13.5
4.3	40	36.2	1.32	108	500	441	14.2
5.9	45	40.6	1.46	119	550	485	15.6
7.4	50	44.9	1.60	130	600	529	17.0
8.9	55	49.1	1.75	141	650	573	18.5
10.4	60	53.5	1.88	152	700	617	19.9
11.8	65	57.9	2.02	163	750	661	21.3
13.1	70	62.3	2.15	173	800	705	22.7
14.5	75	67.6	2.31	184	850	749	24.2
15.8	80	71.0	2.42	195	900	793	25.6
17.0	85	75.1	2.55	206	950	837	27.0
18.2	90	79.6	2.68	217	1 000	882	28.4
19.4	95	84.2	2.81	260	1 200	1 058	34.1
20.6	100	88.4	2.95	302	1 400	1 234	39.8
23.0	110	97.1	3.21	347	1 600	1 411	45.5
25.0	120	105.9	3.49	390	1 800	1 587	51
27.5	130	114.8	3.77	433	2 000	1 763	57
29.8	140	123.6	4.04	542	2 500	2 204	71
32.1	150	132.4	4.32	650	3 000	2 646	85
34.3	160	141.1	4.59	758	3 500	3 087	99
36.5	170	150.0	4.88	867	4 000	3 526	114
38.8	180	158.8	5.15	974	4 500	3 967	128
41.0	190	167.5	5.44	1 082	5 000	4 408	142
43.2	200	176.4	5.72	1 150	5 500	4 849	156
47.5	220	194.0	6.28	1 300	6 000	5 290	170
51.9	240	212	6.85	1 400	6 500	5 730	185
56.5	260	229	7.38	1 510	7 000	6 171	199
60.5	280	247	7.95	1 630	7 500	6 612	213
64.9	300	265	8.51	1 740	8 000	7 053	227
70.3	325	287	9.24	1 850	8 500	7 494	242
75.8	350	309	9.95	1 960	9 000	7 934	256
81.2	375	331	10.7	2 070	9 500	8 375	270
86.8	400	353	11.4	2 200	10 000	8 816	284
92.0	425	375	12.1				
97.4	450	397	12.8				

Appendix table-11: Hardness conversion table (reference)

Rockwell hardness C scale 1 471.0 N	Vickers hardness	Brinell hardness		Rockwell hardness		Shore hardness
		Standard steel balls	Tungsten carbide steel balls	A scale 588.4 N	B scale 980.7 N	
68	940			85.6		97
67	900			85.0		95
66	865			84.5		92
65	832		739	83.9		91
64	800		722	83.4		88
63	772		705	82.8		87
62	746		688	82.3		85
61	720		670	81.8		83
60	697		654	81.2		81
59	674		634	80.7		80
58	653		615	80.1		78
57	633		595	79.6		76
56	613		577	79.0		75
55	595	—	560	78.5		74
54	577	—	543	78.0		72
53	560	—	525	77.4		71
52	544	500	512	76.8		69
51	528	487	496	76.3		68
50	513	475	481	75.9		67
49	498	464	469	75.2		66
48	484	451	455	74.7		64
47	471	442	443	74.1		63
46	458	432	432	73.6		62
45	446	421	421	73.1		60
44	434	409	409	72.5		58
43	423	400	400	72.0		57
42	412	390	390	71.5		56
41	402	381	381	70.9		55
40	392	371	371	70.4	—	54
39	382	362	362	69.9	—	52
38	372	353	353	69.4	—	51
37	363	344	344	68.9	—	50
36	354	336	336	68.4	(109.0)	49
35	345	327	327	67.9	(108.5)	48
34	336	319	319	67.4	(108.0)	47
33	327	311	311	66.8	(107.5)	46
32	318	301	301	66.3	(107.0)	44
31	310	294	294	65.8	(106.0)	43
30	302	286	286	65.3	(105.5)	42
29	294	279	279	64.7	(104.5)	41
28	286	271	271	64.3	(104.0)	41
27	279	264	264	63.8	(103.0)	40
26	272	258	258	63.3	(102.5)	38
25	266	253	253	62.8	(101.5)	38
24	260	247	247	62.4	(101.0)	37
23	254	243	243	62.0	100.0	36
22	248	237	237	61.5	99.0	35
21	243	231	231	61.0	98.5	35
20	238	226	226	60.5	97.8	34
(18)	230	219	219	—	96.7	33
(16)	222	212	212	—	95.5	32
(14)	213	203	203	—	93.9	31
(12)	204	194	194	—	92.3	29
(10)	196	187	187	—	90.7	28
(8)	188	179	179	—	89.5	27
(6)	180	171	171	—	87.1	26
(4)	173	165	165	—	85.5	25
(2)	166	158	158	—	83.5	24
(0)	160	152	152	—	81.7	24

Remarks: Quoted from hardness conversion table (SAE J 417)

Appendix table-12: Greek alphabet list

Roman type (upright)	Italic type (slanted)		Name
	Upper case	Lower case	
A	<i>A</i>	<i>α</i>	Alpha
B	<i>B</i>	<i>β</i>	Beta
Γ	<i>Γ</i>	<i>γ</i>	Gamma
Δ	<i>Δ</i>	<i>δ</i>	Delta
E	<i>E</i>	<i>ε</i>	Epsilon
Z	<i>Z</i>	<i>ζ</i>	Zeta
H	<i>H</i>	<i>η</i>	Eta
Θ	<i>Θ</i>	<i>θ</i>	Theta
I	<i>I</i>	<i>ι</i>	Iota
K	<i>K</i>	<i>κ</i>	Kappa
Λ	<i>Λ</i>	<i>λ</i>	Lambda
M	<i>M</i>	<i>μ</i>	Mu
N	<i>N</i>	<i>ν</i>	Nu
Ξ	<i>Ξ</i>	<i>ξ</i>	Xi
O	<i>O</i>	<i>ο</i>	Omicron
Π	<i>Π</i>	<i>π</i>	Pi
P	<i>P</i>	<i>ρ</i>	Rho
Σ	<i>Σ</i>	<i>σ</i>	Sigma
T	<i>T</i>	<i>τ</i>	Tau
Υ	<i>Υ</i>	<i>υ</i>	Upsilon
Φ	<i>Φ</i>	<i>φ</i>	Phi
X	<i>X</i>	<i>χ</i>	Khi
Ψ	<i>Ψ</i>	<i>ψ</i>	Psi
Ω	<i>Ω</i>	<i>ω</i>	Omega

