



SELF-ALIGNING BEARING UNITS

Accessible quality

NTN 

www.ntn-snr.com



With You

INNOVATION DRIVING YOUR PRODUCTION

Movement is constantly changing. It is analysed, brought under control, guided and mastered with the aim of deriving maximum benefit. It is more than a simple concept. It is the very essence of our commitment, namely designing and innovating to deliver the perfect solutions to the issues and constraints of today and tomorrow.

There are thousands of us around the world masterminding and developing solutions to raise the bar on your production performance. Our world-leading brands (NTN, BCA, BOWER and SNR) are marketed worldwide and deliver the best-fit solutions for working together and building a more environmentally-friendly society. Follow our lead and use interaction, anticipation and adaptation as the keys to guiding and shaping the future of the manufacturing, automotive and aviation markets.

5,4 BILLION €

in revenue in 2019

24 199

employees in 2019

The local service of an international partner

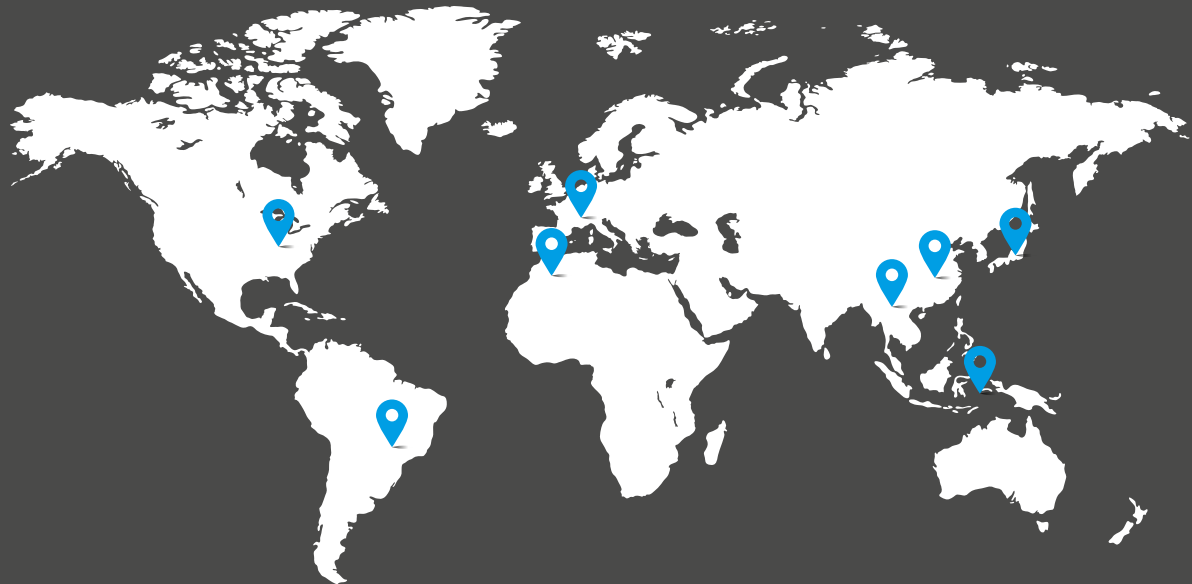

118

sales offices

73































production sites

15







R&D centres











CAST IRON HOUSINGS WITH CHROME STEEL BEARING INSERTS

HOUSINGS	BEARING INSERTS	Page							Suitable protective covers for combination with (available for shaft-Ø 12-65mm)*	
			UC2..G2 / UC3..G2	US2..G2	EX2..G2 / EX3..G2	ES2..G2	LK2..G2H	UK2..G2H / UK3..G2H	UC2..G2 / US2..G2 / LK2..G2H / UK2..G2H	EX2..G2 / ES2..G2
	PE2	A2	UCPE2	USPE2	EXPE2	ESPE2	LKPE2+H	UKPE2+H	SCC2 / SC02	SCCE2 / SC0E2
	PLE2	A6	UCPLE2	USPLE2	EXPLE2	ESPLE2	LKPLE2+H	UKPLE2+H	SCC2 / SC02	SCCE2 / SC0E2
	P2 / P3	A10	UCP2 / UCP3	USP2	EXP2 / EXP3	ESP2	LKP2+H	UKP2+H / UKP3+H	SCC2 / SC02	SCCE2 / SC0E2
	PH2	A18	UCPH2	USPH2	EXPH2	ESPH2	LKPH2+H	UKPH2+H	SCC2 / SC02	SCCE2 / SC0E2
	PAE2	A20	UCPAE2	USPAE2	EXPAE2	ESPAE2	LKPAE2+H	UKPAE2+H	SCC2 / SC02	SCCE2 / SC0E2
	PG2	A24	UCPG2	USPG2	EXPG2	ESPG2	LKPG2+H	UKPG2+H	SCC2 / SC02	SCCE2 / SC0E2
	PA2	A28	UCPA2	USPA2	EXPA2	ESPA2	LKPA2+H	UKPA2+H	SCC2 / SC02	SCCE2 / SC0E2
	FE2	A32	UCFE2	USFE2	EXFE2	ESFE2	LKFE2+H	UKFE2+H	SCC2 / SC02	SCCE2 / SC0E2
	F2 / F3	A36	UCF2 / UCF3	USF2	EXF2 / EXF3	ESF2	LKF2+H	UKF2+H / UKF3+H	SCC2 / SC02	SCCE2 / SC0E2
	FCE2	A44	UCFCE2	USFCE2	EXFCE2	ESFCE2	LKFCE2+H	UKFCE2+H	-	-
	FC2	A48	UCFC2	USFC2	EXFC2	ESFC	LKFC2+H	UKFC2+H	SCC2 / SC02	SCCE2 / SC0E2
	FEE2	A52	-	USFEE2	-	ESFEE	-	-	-	-
	FTE2	A54	-	USFTE2	-	ESFTE	-	-	-	-
	FLE2	A56	UCFLE2	USFLE2	EXFLE2	ESFLE2	LKFLE2+H	UKFLE2+H	SCC2 / SC02	SCCE2 / SC0E2
	FL2 / FL3	A60	UCFL2 / UCFL3	USFL2	EXFL2 / EXFL3	ESFL2	LKFL2+H	UKFL2+H / UKFL3+H	SCC2 / SC02	SCCE2 / SC0E2
	FLZ2	A68	UCFLZ2	USFLZ2	EXFLZ2	ESFLZ2	LKFLZ2+H	UKFLZ2+H	-	-
	FD2	A72	-	USFD2	-	ESFD2	-	-	-	-
	FAE2	A74	-	USFAE2	-	ESFAE2	-	-	-	-
	FA2	A76	UCFA2	USFA2	EXFA2	ESFA2	LKFA2+H	UKFA2+H	SCC2 / SC02	SCCE2 / SC0E2
	FS3	A80	UCFS3	-	EXFS3	-	-	UKFS3+H	-	-
	T2 / T3	A84	UCT2 / UCT3	UST2	EXT2 / EXT3	EST2	LKT2+H	UKT2+H / UKT3+H	SCC2 / SC02	SCCE2 / SC0E2
	T2+WB	A92	UCT2+WB	UST2+WB	EXT2+WB	EST2+WB	LKT2+H+WB	UKT2+H+WB	SCC2 / SC02	SCCE2 / SC0E2
	SP2	A96	UCSP2	USSP2	EXSP2	ESSP2	LKSP2+H	UKSP2+H	SCC2 / SC02	SCCE2 / SC0E2
	C2 / C3	A102	UCC2 / UCC3	USC2	EXC2 / EXC3	ESC2	LKC2+H	UKC2+H / UKC3+H	-	-
	EHE2	A110	UCEHE2	USEHE2	EXEHE2	ESEHE2	LKEHE2+H	UKEHE2+H	-	-







PRESSED STEEL HOUSINGS WITH CHROME STEEL BEARING INSERTS

HOUSINGS	BEARING INSERTS	Page		
			US2..G2	ES2..G2
	PP2	A114	USPP2	ESPP2
	PF2	A116	USPF2	ESPF2
	PFL2	A118	USPFL2	ESPFL2
	PFT2	A120	USPFT2	ESPFT2
	PFE2	A120	USPFE2	ESPFE2

STAINLESS STEEL HOUSINGS WITH STAINLESS STEEL BEARING INSERTS

HOUSINGS	BEARING INSERTS	Page				Suitable protective covers for combination with (available for shaft-Ø 12-60mm)*	
			SUC2	SUC2..FG1**	SES2	SUC2 / SUC2..FG1**	SES2
	SP2	A192	SUCP2	SUCP2..FG1	SESP2	SCC2 / SC02	SCCE2 / SC0E2
	SPA2	A194	SUCPA2	SUCPA2..FG1	SESPA2	SCC2 / SC02	SCCE2 / SC0E2
	SF2	A196	SUCF2	SUCF2..FG1	SESF2	SCC2 / SC02	SCCE2 / SC0E2
	SFL2	A198	SUCFL2	SUCFL2..FG1	SESFL2	SCC2 / SC02	SCCE2 / SC0E2
	SFB2	A200	SUCFB2	SUCFB2..FG1	SESF2	SCC2 / SC02	SCCE2 / SC0E2
	ST2	A202	SUCT2	SUCT2..FG1	SEST2	SCC2 / SC02	SCCE2 / SC0E2

THERMOPLASTIC HOUSINGS WITH STAINLESS STEEL BEARING INSERTS

HOUSINGS	BEARING INSERTS	Page			Suitable protective caps (available for shaft-Ø 15-40 mm)
			MUC2..FD	SUC2..FG1**	CV2 / CF2
	PPL2	A204	MUCPPL2	SUCPPL2..FG1	CV2 / CF2
	TBL2	A204	MUCTBL2	SUCTBL2..FG1	CV2 / CF2
	FPL2	A206	MUCFPL2	SUCFPL2..FG1	CV2 / CF2
	NFL2	A206	MUCNFL2	SUCNFL2..FG1	CV2 / CF2
	FBL2	A206	MUCFBL2	SUCFBL2..FG1	CV2 / CF2

* The protective covers are fixed in housing grooves. For units that are to be fitted with protective covers, housings with suffix N must be ordered. Units already ordered with cover(s) are automatically delivered with grooved housings.

** LUBSOLID® filling

GENERAL INFORMATION

OUR BEARING UNITS: INGENUOUSLY SIMPLE

A bearing unit consists of a ball bearing insert and a housing. The two components can easily be assembled together due to their spherically shaped bearing seats. The bearing inserts are angularly movable and compensate for slight static misalignment of the shaft.

Swivelling or tumbling motion must not act in dynamic operation.

G2 SYSTEM: THE UNIVERSAL SNR BEARING INSERT

All ball bearing inserts with suffix G2 are **equipped with four lubrication bores in two planes**. This re-lubrication system **allows reversed installation of inserts and can thus be used in either housing designs produced according to the JIS and ISO standard**.

This system significantly **increases flexibility**, especially for those who prefer to keep single components in stock and pair them together when needed. This is a cost effective option, using fewer part numbers and saving warehouse space.

EUROPEAN ISO VERSUS ASIAN JIS SERIES

The JIS and ISO manufactured bearing units only vary slightly in their dimensions. Some housing designs also have minor differences in shape. However, **the typical distinguishing feature is the arrangement of the lubrication groove on the bearing seat of the housing**. Therefore, **all SNR bearing inserts are equipped with G2 system to enable relubrication in both housing designs!**

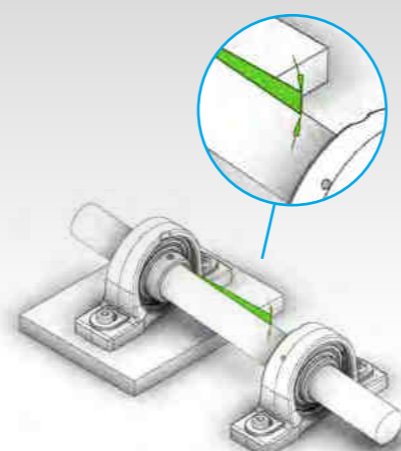

Bearing units can cope with a high degree of mounting errors



G2 System: Outer ring with four lubrication bores in two planes

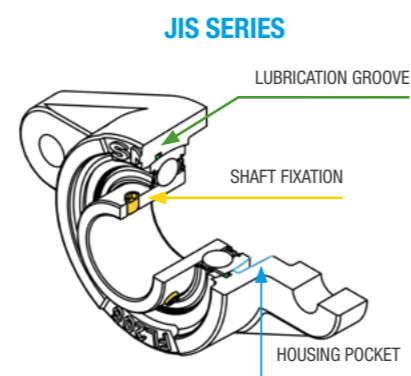
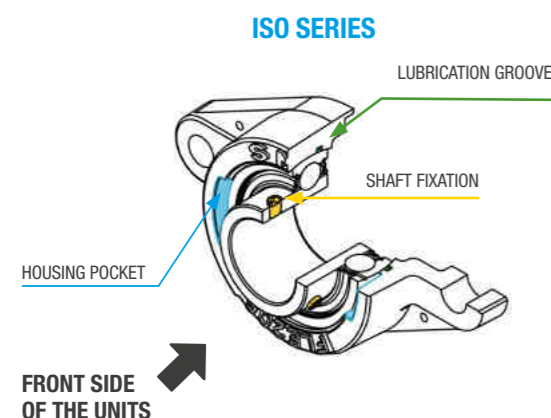

SNR SELF-ALIGNING BEARING UNITS

ACCESSIBLE QUALITY!

Whether universal or industry-specific, the SNR range of self-aligning bearing units offers many solutions for bearing arrangements in industrial applications.

The portfolio comprises **more than 40,000 different part numbers**. Due to their **uncomplicated design**, the bearing units **can be mounted without special technical expertise**. The simple mounting and low-maintenance operation **ensure an economical rolling bearing solution**.

Housings in the SNR range are **available in a variety of materials**: cast iron, pressed steel, stainless steel and thermoplastic. All single-piece housings are **supplied with a re-greasing system to provide for lubrication of the bearing inserts**.

However, in many applications re-lubrication is not necessary due to inserts being based on greased for life deep groove ball bearings of series 62 and 63.

YOUR BENEFITS WITH SNR BEARING UNITS AT A GLANCE:

ONE STOP SHOP FOR ALL YOUR BEARING UNIT NEEDS

- Save time and money
- Find everything that you need in our comprehensive range of quality products from JIS and ISO ranges

IMPROVE YOUR REACTIVITY THANKS TO SHORT LEAD TIMES

- Control emergency situations
- A high level of product availability in our European Distribution Centre allows you to manage all situations

OPTIMISE THE OUTPUT OF YOUR MACHINES WITH OUR COMPLETE PRODUCT EXPERTISE

- Define the best suitable bearing unit combinations
- Benefit from the advice of our highly skilled engineering team for your specific applications

For more technical data, flash the QR CODES



DIMENSIONS AND
TECHNICAL SPECIFICATIONS



3D CAD
MODELS



ONLINE
DOCUMENTS





ANSWER EACH OF YOUR APPLICATION NEEDS

Offering exceptional value for money, the SNR bearing unit range provides solutions for a wide field of applications such as: farming machinery, food-processing, material handling, packaging machines, wood industry and many others.

NTN-SNR provides you all the products needed for each step of your production.

The majority of our products are available from stock.



CONTENTS

BEARING UNITS

CAST IRON	8
PRESSED STEEL	11
STAINLESS STEEL	12
THERMOPLASTIC	14

BALL BEARING INSERTS WITH SHAFT FASTENING

SET SCREW TYPE	16
ECCENTRIC LOCKING COLLAR TYPE	18
ADAPTER SLEEVE TYPE	20
INTERFERENCE FIT TYPE	20

SEALING SOLUTIONS

21

LUBSOLID® BEARING INSERTS

22

AGR BEARING INSERTS

23

PROTECTIVE COVERS

24

PROTECTIVE CAPS

FOR BEARING UNITS FROM CAST IRON	25
FOR BEARING UNITS FROM THERMOPLASTIC	25

SUFFIX & PREFIX

26

OTHER MOUNTED UNITS

BEARING HOUSINGS WITH GREASE LUBRICATION	27
BEARING HOUSINGS WITH OIL LUBRICATION	28



CAST IRON BEARING UNITS FOR VARIOUS INDUSTRIES

BENEFITS

QUALITY, VALUE AND PERFORMANCE

- Optimized design
- Cost efficiency orientation

FULL RANGE OF OPTIONS TO SATISFY YOUR NEEDS

- The width of the range with its multiple possibilities will make you find the most appropriate solution for your needs

QUICK DELIVERY TO FIT YOUR REQUIREMENTS

- Popular range available from our European stock

TECHNICAL CHARACTERISTICS

- Housings made of quality cast iron
- Multiple housing shapes: Pillow blocks, flanged units, tensioner, hanger and cartridge units
- Available from shaft diameter 12 – 140 mm / 1/2 - 3 15/16 inch
- Equipped with universal inserts (G2 system design - see page 4)
- JIS & ISO ranges available
- Relubrication facilities on all housings as standard
- Painted housings with excellent anti-corrosion properties

SPECIFIC FEATURES

- Rigid protective covers from stainless steel available for many bearing units (bore code 201-213)
- Adapter sleeve included for tapered bore bearing units with insert series UK2..G2H, UK3..G2H and LK2..G2H
- Heavy duty series 300 available from stock

DESIGNATIONS

CAST IRON SERIES



USAGE EXAMPLES

CONVEYOR SYSTEMS

BEARING UNIT CHARACTERISTICS:

- Installation-friendly design
- Low maintenance requirements
- Ideally suited in conveyor systems for rollers, idler and pulleys
- Work imperceptibly and trouble-free to guarantee the operational function in every facility and all environments

TYPICAL SPECIFICATIONS TO BEARING UNITS IN CONVEYOR SYSTEMS:

- **Fast tensioning and release system for rollers**
Tensioner units with welded frame T200 + WB, SP + SPR, FA200 and FAE200 with slotted hole
- **Injury prevention against turning shaft ends**
Installation of protective cap PCC (closed) or PCO (open)
- **Small installation space**
FD series with narrow set screw bearing insert US..G2 or eccentric locking collar type ES..G2
- **Designed for higher loads**
Series 300 available as pillow block, flange or tensioner unit
- **Protection against impacts, dust and humidity**
Bearing units with protective covers SCC (closed) or SCO (open), Bearing inserts with AGR or L4 seal system
- **Change of rotation direction or high rotation speeds**
Bearing inserts with adapter sleeve type UK..G2H or LK..G2H or bearing insert type CS with interference fit

To move objects from one location to another, conveyor systems work in many industrial applications.



AGRICULTURE

BEARING UNIT CHARACTERISTICS:

- User-friendly design
- Service-free operation
- Ability to compensate static shaft misalignment

The SNR range of bearing units is under continuous development. For decades, NTN-SNR is working with outstanding partners in the farming industry.



TYPICAL REFERENCES FOR FARMING MACHINERY:

References	Dimensions (mm)			Seal type	
	d	L	J		
EXFE308A05AGR	40.000	130.000	101.500	AGR	
EXPAE206L3	30.000	98.000	76.200	L3	
EXPAE208L3	40.000	116.000	88.900	L3	
UCFE308A05AGR	40.000	130.000	101.500	AGR	
UCF208AGRLP	40.000	130.000	102.000	AGR	
D-UCF210A10AGR	50.000	143.000	111.000	AGR	
D-UCF212A10AGR	60.000	175.000	143.000	AGR	
UCF212AGR	60.000	175.000	143.000	AGR	
UCFC212L3	60.000	175.000	143.000	L3	
XUCFE308A05B168	40.000	130.000	101.500	AGR	
XUCFE308B01B169	40.000	130.000	101.500	AGR + L4	



FOR IMPLEMENTS IN AGRICULTURE MACHINERY



PRESSED STEEL BEARING UNITS

BENEFITS

BEST ECONOMICAL SOLUTION FOR LIGHTWEIGHT CONSTRUCTIONS

- Particularly used in applications where weight is a major constraint

TECHNICAL CHARACTERISTICS

- Two-piece housing made from zinc coated sheet steel
- Available as pillow block, flanged or take-up unit
- Equipped with universal inserts (G2 system design - see page 4)
- Suitable for narrow ball bearing inserts set screw type US..G2, eccentric locking collar type ES..G2 and type CS with interference fit
- Made for low to moderate loads & speeds



DESIGNATIONS

PRESSED STEEL SERIES

US PFL 207

BEARING INSERT

US..G2: Chrome steel bearing insert with shaft fastening with socket set screws, narrow design

ES..G2: Chrome steel bearing insert with shaft fastening with eccentric locking collar, narrow design

HOUSING

PP: Pillow block

PF: Three or four-bolt flange, round design

PFL: Two-bolt flange, oval design

PFT: Three-bolt flange, triangular design

PFE: Take-up unit for shaft adjustment, rectangular design

BORE CODE

201 to 212
(bore- Ø 12 – 60 mm)



FOR USE IN THE CHEMICAL, PHARMACEUTICAL AND FOOD-PROCESSING INDUSTRIES

STAINLESS STEEL BEARING UNITS



BENEFITS

PREMIUM LINE

- Optimum performance with a strong focus on protection from oxidation, mould, bacteria and chemical cleaning agents
- High performance lubricant
- High-quality stainless steel
- Relubrication facility on all housings

RESILIENT

- Excellent mount stability and impact resistance
- Recess-free housing contact surface to prevent deposits of the process material
- Designed to withstand aggressive cleaning and corrosive environments
- Open or closed protective covers from stainless steel available for all housings

LESS DOWNTIME MORE PROFITABILITY

- Protective covers for units provide additional protection during high pressure washdown



TECHNICAL CHARACTERISTICS

- 100% stainless steel resistant to corrosion: will never chip and contaminate the end product
- Food-grade seal with additional slinger (SUC)
- USDA H1 grease fully compliant with FDA regulations
- Shaft fastening by set screw or eccentric locking collar
- Metal cage
- The protective covers are fixed in housing grooves

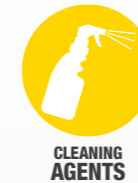

DESIGNATIONS

STAINLESS STEEL SERIES

SUC F 206 FG1 CO

BEARING INSERT

SUC: Stainless steel bearing insert with shaft fastening by socket set screw

SES: Stainless steel bearing insert with shaft fastening by eccentric locking collar

SUC..FG1: Stainless steel bearing insert with shaft fastening by socket set screw, LUBSOLID® filling

HOUSING

SP: Pillow block

SPA: Tap base pillow block

SF: Four-bolt flange

SFL: Two-bolt flange

SFB: Three-bolt flange

ST: Take-up

BORE CODE

201 to 212

(bore- Ø 12 – 60 mm)

LUBSOLID®

Only when the unit is equipped with **LUBSOLID® bearing insert**

PROTECTIVE COVER

For use with SUC

SCO: open covers

SCC: closed covers

For use with SES

SCOE: open covers

SCCE: closed covers

Housing prepared for covers installation: **N**

⚠ For units that are to be fitted with protective covers, housings with suffix N must be ordered. Units already ordered with cover(s) are automatically delivered with grooved housings.



FOR FOOD-PROCESSING AND RELATED ENVIRONMENTS

THERMOPLASTIC BEARING UNITS

BENEFITS

EASY TO CLEAN

- Resistant to numerous chlorine-containing and corrosive cleaning solutions
- Insensitive to bacteria formation
- Recess-free housing contact surface to prevent deposits of the process material
- Protective caps for units to provide additional protection against regular wash downs
- Smooth surfaces

RESILIENT

- Good friction and wear properties
- Mounting holes reinforced with metal bushings
- Equipped with bearing inserts from stainless steel



TECHNICAL CHARACTERISTICS

- 100% stainless steel bearing inserts resistant to corrosion: will never chip and contaminate the end product
- All metallic components made of high-quality stainless steel
- Food-grade seal with additional slinger
- High performance lubricant according to NSF H1
- Metal cage

SPECIFIC FEATURES

- Relubrication facility on all housings
- Additional protection through open or closed end covers (tool-free installation)
- Can optionally be combined with food-grade solid grease bearing insert



HIGH PRESSURE WASHING



CLEANING AGENTS



HUMIDITY



HYGIENE STANDARDS



SUITABLE FOR THE USE OF LUBSOLID® BEARING INSERTS

DESIGNATIONS

THERMOPLASTIC SERIES

MUC PPL 206

BEARING INSERT

MUC..FD: Stainless steel bearing insert with shaft fastening by socket set screw

SUC..FG1: Stainless steel bearing insert with shaft fastening by socket set screw, LUBSOLID® filling

HOUSING

PPL: Pillow block

TBL: Tap base pillow block

FPL: Four-bolt flange

NFL: Two-bolt flange

FBL: Three-bolt flange

BORE CODE

204 to 208
(bore- Ø 20 – 40 mm)

PROTECTIVE CAP

All housings are equipped with appropriate grooves where caps can snap into place

CV: open cap

CF: closed cap

⚠ Protective caps must be ordered separately.

BALL BEARING INSERTS



SHAFT FASTENING WITH SET SCREWS

Available for metric and imperial shafts

SPHERICAL OUTER RING



UC / SUC / MUC / ZUC
with wide inner ring design



US
with narrow inner ring design

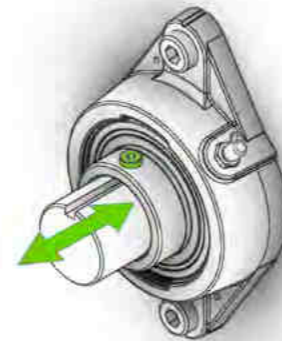

By replacing the set screws, bearing inserts type UC and US can easily be converted into a floating bearing arrangement.

CYLINDRICAL OUTER RING



CUC
with wide inner ring design



CUS
with narrow inner ring design

TECHNICAL CHARACTERISTICS

- Easy and quick to install on the shaft
- Suitable for applications with alternating directions of shaft rotation
- Equipped with two self-locking cup point set screws for a safe and secure fastening of the bearing to the shaft
- No special mounting tools required
- For floating bearing arrangements by using optional floating screw SH (available for all bearing units series UC2 and UC3)

SET SCREW TYPES

Bearing insert	Shaft-Ø [mm]	Bearing material	Inner ring design	Seal (on both sides)	Specific characteristics / possible use	
UC2..G2 / UC3..G2	12-140	Steel	Wide	1-lip seal and slinger	Basic version.	
UC2..G2L3	12-90			Triple lip seal	For applications in heavily dirt contaminated environments.	
UC2..G2L4	12-50			Multiple seal system	Zinc-coating, reduced internal clearance, for heavily dirt contaminated environments, moderate torque, corrosion protected.	
UC2..AGR*	30-60			AGR seal system	Zinc-coating, 90% grease filling, maintenance-free, powerful seal with massive steel protector for heavily polluted applications.	
UC2..G2T04 / UC3..G2T04	12-140			1-lip seal and slinger	Operating temperature down to -40°C.	
UC2..G2T20	12-90			Labyrinth seal	Black-oxide-coated, increased internal clearance, for permanent operating temperature up to +200°C.	
US2..G2	12-60			Narrow	1-lip seal	Basic version.
US2..G1N**	25-40					For use with protective caps PCC and PCO.
US2..G2T04	12-60					Operating temperature down to -40°C.
US2..G2T20	12-60					Black-oxide-coated, increased internal clearance, for permanent operating temperature up to +200°C.
SUC2	12-60	Stainless steel	Wide			Food-grade grease filling, outer ring with anti-rotation pin, approved for the direct contact with foodstuffs.
SUC2..FG1	20-60			LUBSOLID® food-grade grease filling, outer ring with anti-rotation pin, maintenance-free, anti-contamination effect, for the most stringent food safety requirements.		
MUC2..FD	20-40			Food-grade grease filling, outer ring with anti-rotation pin, reduced internal clearance, approved for the direct contact with foodstuffs.		
ZUC2..FG	20-40			Zinc-coating, food-grade grease filling, cost-effective alternative for food applications without direct contact to foodstuffs.		
CUC2	20-50			Steel	Wide	Cylindrical outer ring with snap ring groove for axial fixation, lubrication hole, not for use in standard housings with spherically shaped bearing seat.
CUS2	20-50					Narrow

* not for use in all standard housings

** suitable for the installation in ISO flanged-housings

SHAFT FASTENING WITH ECCENTRIC LOCKING COLLAR

Available for metric and imperial shafts

SPHERICAL OUTER RING



EX
with wide inner ring design



ES / SES
with narrow inner ring design

CYLINDRICAL OUTER RING



CEX
with wide inner ring design



CES
with narrow inner ring design

TECHNICAL CHARACTERISTICS

- For higher loads in axial direction compared to set screw types
- Particularly easy to fit
- Decreased damage of shaft surface
- Easier to disassemble
- Only suitable for one direction of rotation

ECCENTRIC LOCKING COLLAR TYPES

Bearing insert	Shaft-Ø [mm]	Bearing material	Inner ring design	Seal (on both sides)	Specific characteristics / possible use	
EX2..G2 / EX3..G2	12-140	Steel	Wide	1-lip seal and slinger	Basic version.	
EX2..G2L3	12-90			Triple lip seal	For applications in heavily dirt contaminated environments.	
EX2..G2L4	12-55			Multiple seal system	Zinc-coating, reduced internal clearance, for heavily dirt contaminated environments, moderate torque, corrosion protected.	
EX2..AGR*	35-60			AGR seal system	Zinc-coating, 90% grease filling, maintenance-free, powerful seal with massive steel protector for heavily polluted applications.	
EX2..G2T04 / EX3..G2T04	12-90			1-lip seal and slinger	Operating temperature down to -40°C.	
EX2..G2T20	12-90			Labyrinth seal	Black-oxide-coated, increased internal clearance, for permanent operating temperature up to +200°C.	
ES2..G2	12-60			Narrow	1-lip seal	Basic version.
ES2..G2T04	12-60					Operating temperature down to -40°C.
ES2..G2T20	12-60					Black-oxide-coated, increased internal clearance, for permanent operating temperature up to +200°C.
ES2..G1N**	15-45					For use with protective caps PCC and PCO.
SES2	12-60	Stainless steel	Food-grade grease filling, approved for the direct contact with foodstuffs.			
CEX2	20-50	Steel	Wide	1-lip seal and slinger	Cylindrical outer ring with snap ring groove for axial fixation, lubrication hole, not for use in standard housings with spherically shaped bearing seat.	
CES2	20-50		Narrow	1-lip seal	Cylindrical outer ring with snap ring groove for axial fixation, without relubrication facility, not for use in standard housings with spherically shaped bearing seat.	

* not for use in all standard housings

** suitable for the installation in ISO flanged-housings

SHAFT FASTENING WITH ADAPTER SLEEVE

UK..H available for metric and imperial shafts
LK..H available for metric shafts



UK..H
with wide inner ring design



LK..H
with narrow inner ring design

To increase the rotational speed or the running smoothness of a machine, use LK..H. It simply replaces bearing inserts with set screws or eccentric locking collars. Despite using the adapter sleeve, the shaft diameter will not be modified and neither the adjacent construction (shaft and housing).

TECHNICAL CHARACTERISTICS

- Highly suitable for shafts with frequent rotation reversals
- For higher speeds
- No damage of the shaft surface
- Are connected to the shaft concentrically by a force locking connection (particularly quiet in operation)
- Special tool required for correct mounting
- Shaft diameter reduction (only UK..H)

Bearing insert	Bearing material	Inner ring design	Seal (on both sides)	Shaft-Ø [mm]	Specific characteristics / possible use
UK2..G2H / UK3..G2H	Steel	Wide	1-lip seal and slinger	20-125	Adapter sleeve type H23 included, increased internal clearance, enable a concentric and force-fit connection of the bearing on the shaft, suited for frequent change of rotation direction and high rotation speeds, smooth running.
LK2..G2H		Narrow	1-lip seal	20-50	Adapter sleeve included, increased internal clearance, enable a concentric and force-fit connection of the bearing on the shaft, no shaft diameter reduction, suited for frequent change of rotation direction and high rotation speeds, smooth running.

SHAFT FASTENING WITH INTERFERENCE FIT

CS available for metric shafts



CS
without inner ring extension

Bearing insert	Bearing material	Inner ring design	Seal (on both sides)	Shaft-Ø [mm]	Specific characteristics / possible use
CS2	Steel	Narrow	1-lip seal	12-50	Interference fit, without relubrication facility, suited for high rotational shaft speeds, smooth running.

SEALING SOLUTIONS



Seals for insert bearings	References	Technical characteristics	Benefits
	One-lip seal with protective edge US..G2, US..G1N, US..G2T04, US..G2T20, CUS, ES..G2, ES..G1N, ES..G2T04, ES..G2T20, SES, CES, LK..G2H	Zinc-coated sheet steel retainer* with vulcanised seal. The axially preloaded seal lip from NBR** is located behind a protective edge. * Stainless steel for SES Black-oxide-coated for T20 ** Silicon for SES and design T20	<ul style="list-style-type: none"> • Normal environmental conditions • Medium to high rotation speeds
	One-lip seal CS	Sheet steel retainer over-moulded with NBR material. Axially preloaded seal lip.	<ul style="list-style-type: none"> • Normal environmental conditions • Medium to high rotation speeds
	One-lip seal with slinger UC..G2, UC..G2T04, SUC, MUC.FD, EX..G2, EX..G2T04, CEX, UK..G2H	Zinc-coated sheet steel retainer* over-moulded with NBR and axially preloaded seal lip** + preconnected, zinc-coated sheet steel slinger* for improved protection against mechanical impacts. * Stainless steel for SUC ** Silicon for SUC / Food grade NBR for MUC.FD	<ul style="list-style-type: none"> • Additional protection against particles • Medium to high rotation speeds
	Triple lip seal UC..G2L3, EX..G2L3	Zinc-coated sheet steel retainer with vulcanised triple lip seal. The lips from NBR are axially preloaded and angled outwards. The protective edge of the retainer serves as a safeguard against mechanical impacts.	<ul style="list-style-type: none"> • For medium to heavily polluted environments • Lower rotation speed • Higher friction
	Multiple seal system UC..G2L4, EX..G2L4	Two zinc-coated steel sheet elements with vulcanised seal lips from NBR. The internal retainer is equipped with a radial seal to the inner ring, while the external slinger has a radial seal to the outer ring. A third seal lip is intermediate and act axially.	<ul style="list-style-type: none"> • For medium to heavily polluted environments • Medium rotation speeds • Lower friction • Suitable for pressure washing
	High-performance seal system UC..AGR, EX..AGR	Zinc-coated steel sheet retainer with vulcanised triple lip seal. The lips from NBR are axially preloaded and angled outwards. The triple lip seal is completely covered by a massive steel protector. The zinc-coated impact shield is additionally equipped with a lip seal and strongly secured on a knurled seat.	<ul style="list-style-type: none"> • For extremely polluted environments • Shock resistant • Low rotation speeds • Suitable for high-pressure washing • Higher friction
	High temperature non-contact seal UC..T20, EX..T20	Labyrinth seal from two black-oxide-coated steel sheet slinger in parallel arrangement.	<ul style="list-style-type: none"> • For high temperature use • Very low friction



FOR FOOD-PROCESSING INDUSTRY

BEARING INSERT SERIES
SUC..FG1
LUBSOLID®

BENEFITS

INCREASE THE PROFITABILITY AND EFFICIENCY OF YOUR MACHINES

- Up to 20 times longer bearing lifetime
- Higher reliability and maintenance-free operation
- Longer machine operating times: cost savings and productivity gains
- Lower maintenance and material costs

IMPROVE HYGIENE AND SAFETY CONDITIONS

- Anti-contamination effect: no lubricant leakage possible
- Food grade lubricant with NSF certificate
- All metallic components made of high-quality stainless steel
- Insensitive to contamination
- Resistant to cleaning agents

INSTALL AND FORGET

- No need for regular monitoring or service: suited for locations with difficult access
- Ideal match with both bearing unit ranges - thermoplastic and stainless steel

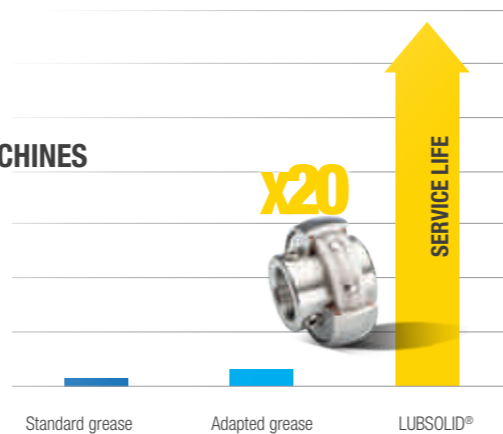

GREASED FOR LIFE



HYGIENE STANDARDS



FOR HARSH ENVIRONMENTS

BEARING INSERT SERIES*
UC..AGR / EX..AGR
AGR

BENEFITS

ROBUST AND RELIABLE

- High durability and resistant to strong mechanical impacts
- Maintenance-free: bearing lubricated for life
- Resistant to high pressure washing
- No risk of deficient lubrication
- No environmental contamination due to leaking lubricants

LESS MACHINE DOWNTIMES, MORE PROFITABILITY

- Better operating performance
- Longer machine operating times: cost saving and productivity gains
- Lower maintenance and material costs

PROFIT FROM THE VARIETY IN USE

Combine AGR bearing inserts with many SNR housings and create the bearing unit that best suits your application, such as: power and disc harrows, shredders / chippers, conveyor systems, crushers, mills...

* Available as bearing insert with set screws UC..AGR and eccentric locking collar EX..AGR

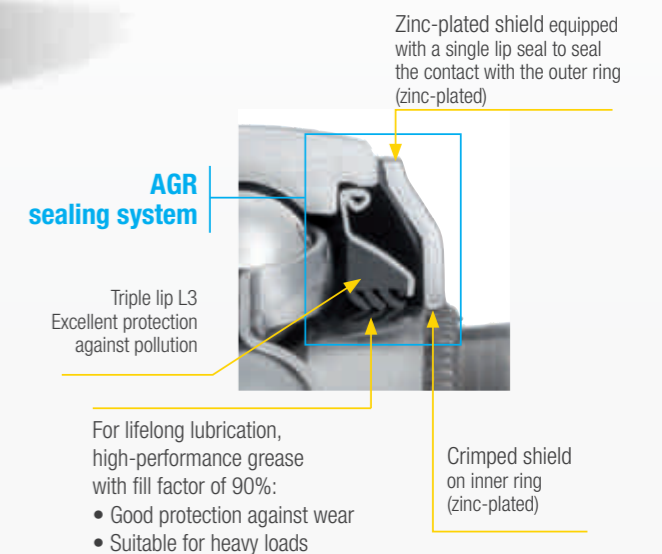

GREASED FOR LIFE

⚠ Bearing inserts from the AGR series cannot be combined with all housings due to the reinforced seal. They have been designed for installation in SNR housings from the P, PE, F, FE and FL, FLE series, but can also be combined with housings from other series. Please consult our technical department if you are interested in other combinations.

PROTECTIVE COVERS





FOR BEARING UNITS FROM CAST IRON AND STAINLESS STEEL

Most of the bearing units made of cast iron or stainless steel can be equipped with additional protective covers. The covers are generally made from stainless steel. They are available as closed or open version with double lip seal for bore code 201 to 213 (shaft- Ø 12 – 65 mm).

BENEFITS

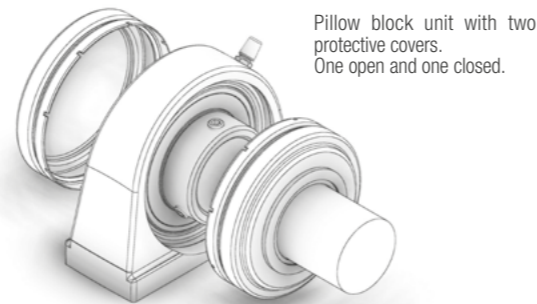
- Improve safety requirements
- Protect the bearing against external influences
- Prevent the discharge of lubricants into sensitive environments
- For shafts ends and through shafts



Suffix	Description	Cover type	Suitable in combination with bearing insert type:	Design
CC	Bearing unit with narrow cover (closed version)	SCC	Set screw, Adapter sleeve, Fit	Open version 
CO	Bearing unit with narrow cover for metric shaft (open version)	SCO		
COU	Bearing unit with narrow cover for imperial shaft (open version)	SCOU		
CCE	Bearing unit with wide cover (closed version)	SCCE	Eccentric locking collar	Closed version 
COE	Bearing unit with wide cover for metric shaft (open version)	SCOE		
COEU	Bearing unit with wide cover for imperial shaft (open version)	SCOEU		
N	Unit / Housing prepared for cover(s) installation	-	/	

- For a very strong fit and an outstanding sealing effect, the protective covers are fixed in housing grooves
- For the installation of protective covers, flanged housings are equipped with one groove on the front side
- All other housings have two machined grooves

⚠ Bearing units that are ordered with cover(s) include the housings with grooves. If you want to install the protective covers later, housings with suffix N must be ordered (for example: P210N).

PROTECTIVE CAPS





FOR EUROPEAN SERIES BEARING UNITS FROM CAST IRON

Available for shaft ends and through going shafts

BENEFITS

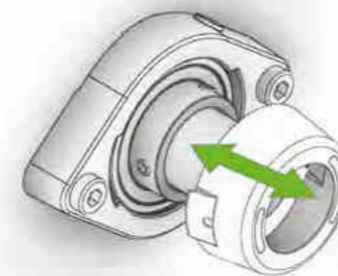
- Reduce the risk of injury from rotating shaft ends
- Protect the bearing to increase its performance in service
- Permit larger deviations in shaft misalignment
- Tool-free installation



Cap type / Suffix	Description	
PCO	Protective cap (open version)	
PCC	Protective cap (closed version)	
G1N	Bearing insert with groove in the outer ring	

Protective caps have to be ordered separately from the bearing units. Due to the special design of the housings, these protective caps can only be fitted on one side.

To install the cap "tool free", bearing insert series G1N must be installed to the bearing unit. These bearings have a special groove machined in their outer rings in which the protector can snap into place (for example: US206G1N).

FOR BEARING UNITS FROM THERMOPLASTIC

Available for shaft ends and through going shafts

All housings of this range are already equipped with appropriate grooves where protective caps can snap into place. Both the closed and the open version with shaft seal are available from bore code 204 to 208 (shaft- Ø 20 – 40 mm).

BENEFITS

- Reduce the risk of injury from rotating shaft ends
- Good sealing effect due to radial shaft seal (CV)
- Prevent the discharge of lubricants into sensitive environments
- Tool-free installation

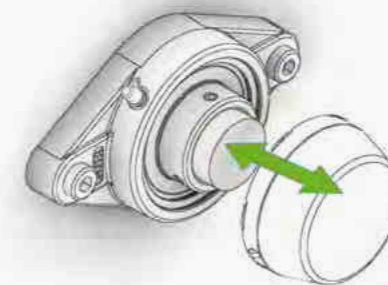

Cap type	Description	
CV	Protective cap (open version)	
CF	Protective cap (closed version)	

SUFFIX & PREFIX

Suffix	
AGR	Service-free bearing insert with high performance seal
CA	Bearing unit ready to be equipped with protector PCC / PCO
CC	Bearing unit with narrow protective cover(s) - closed version
CCE	Bearing unit with wide protective cover(s) - closed version
CO	Bearing unit with narrow protective cover(s) - open version for metric shafts
COE	Bearing unit with wide protective cover(s) - open version for metric shafts
COEU	Bearing unit with wide protective cover(s) - open version for imperial shafts
COU	Bearing unit with narrow protective cover(s) - open version for imperial shafts
FG1	Stainless steel bearing insert with LUBSOLID® food-grade grease filling
FG	Bearing insert with zinc-coating and food-grade grease filling
G1N	Bearing insert with outer ring groove for tool-free protective cap installation
G2	SNR 2-planes re-greasing system with 4 grease bores in the outer ring
H	UK bearing insert equipped with adapter sleeve
L3	Bearing insert with triple lip seal
L4	Bearing insert with multiple seal and reduced rotation torque
N	Housing designed for protective cover(s) installation (machined grooves)
T04	Bearing insert for cold environments (down to - 40°C)
T20	Bearing insert for hot environments (up to + 200°C)

Prefix	
S	Stainless steel type
C	Bearing insert with cylindrical outer ring matching JIS norm
Z	Bearing insert for food-processing industry

OTHER MOUNTED UNITS BEARING HOUSINGS WITH GREASE LUBRICATION



SPLIT PLUMMER BLOCK HOUSING SNC / SNCD500

- SN housing according to ISO113-2010 to house bearings with a cylindrical or tapered bore
- High stiffness and stability under all load conditions
- Optimised heat dissipation
- Reduced stresses in the bearing
- Extended service life and prolonged service intervals
- For shaft diameters from 20 mm to 140 mm
- Housing material: Cast iron with flake graphite and/or spheroidal graphite (SNCD)
- 5 different seal arrangements for a wide range of applications
- User-friendly design features for ease of service and rapid installation



LARGE PLUMMER BLOCK HOUSING SNCD

Split housing according to ISO113-2010 for spherical roller bearings with cylindrical or tapered bore

- Housing material: Spheroidal graphite iron
- Operation temperature down to -40°C
- Optimised heat dissipation
- Wide reinforcing belt and support arch construction for increased dimensional stability
- Extended bearing service life and prolonged service intervals
- Labyrinth and Taconite seal
- Various connections for lubricant supply and condition monitoring sensors
- Shaft diameter 115 to 500 mm



SPW/SFCW – BEARING HOUSINGS FOR HEAVY LOADS

- Suitable for very harsh environments in the timber industry and heavy industry
- Bearing and housing protected against corrosion
- Rapid replacement of the patented bearing unit
- Sealed spherical roller bearing
- Rapid commissioning, increased productivity
- Series SPW interchangeable with SN series bearing housings
- Shaft diameter: 50 to 140 mm



ONE-PIECE BEARING HOUSING ZLG / DLG

- For the installation of two or three rolling bearings
- Grease lubrication
- Suitable for high operating speeds (industrial fans)
- Extremely smooth operation due to precise alignment of the bearings in the housing
- Felt seal with additional V-ring seal
- Easy installation on the clamping area
- Shaft diameter, ZLG: 30 to 120 mm / DLG: 70 to 120 mm



BEARING HOUSINGS FOR SPECIAL APPLICATIONS 722500, F11200, TVN, TN

- Compact sealed housings in grey cast iron
- TVN: suitable for operating temperatures up to +350°C
- Suitable for critical environments: Hot and humid / hot and dry
- Possible applications in constructions of the sand-lime brick or clinker industry
- TVN/TN: can be installed in any position
- Shaft diameter, TVN: 20 to 75 mm / TN: 20 to 60 mm
- F11200 / 722500: flanged housing unit
- Shaft diameter, F11200: 20 to 50 mm / 722500: 20 to 100 mm

BEARING HOUSINGS WITH OIL LUBRICATION



ONE-PIECE BEARING HOUSING ZLOE

- Equipped with two radial contact ball bearings or a combination of a radial contact ball bearing with a cylindrical roller bearing
- Suitable for applications with high load capacities combined with high operating temperatures
- Particularly well-suited for high speed applications, e.g. industrial fans
- Extremely smooth operation due to precise alignment of the bearings in the housing
- Easy installation of the bearing unit on the clamping area
- Labyrinth system provides efficient, low-friction seal
- Can be used with oil circulation or oil injection lubrication
- Shaft diameter: 75 to 120 mm



SPLIT BEARING HOUSING SNOE

- Suitable for spherical roller bearings
- For applications with high operating speeds and heavy loads
- Housing material: EN-GJS for especially high strength and torsional rigidity
- Internal oil distribution via an oil pick-up ring
- Labyrinth sealing system
- Equipped with an oil-level indicator
- Can be used with optional oil circulation, oil cooling or oil pre-heating system
- Excellent heat dissipation
- Application areas: Industrial fans, hammer mills, stone crushers
- Shaft diameter: 70 to 260 mm (the largest standard oil-lubricated bearing housing on the market)



SPLIT BEARING HOUSING SNOL (COMPACT VERSION)

- Suitable for spherical roller bearings
- Low-friction labyrinth seal system
- SNOL bearing housings can replace grease-lubricated units from the SN series. This may be necessary in case of: - Increased operating speeds - Higher operating temperatures - Extended service life - Prolonged maintenance intervals
- Equipped with an oil-level indicator
- Shaft diameter: 60 to 140 mm

Summary

CAST IRON UNITS

CAST IRON HOUSINGS WITH CHROME STEEL BEARING INSERTS

PILLOW BLOCK UNITS

PE2	A2
PLE2	A6
P2	A10
P3, PEX	A14
PH2	A18
PAE2	A20
PG2	A24
PA2	A28

FLANGED UNITS

FE2	A32
F2	A36
FEX, F3	A40
FCE2	A44
FC2	A48
FEE2	A52
FTE2	A54
FLE2	A56
FL2	A60
FE3	A64
FLZ2	A68
FD2	A72
FAE2	A74
FA2	A76
FS3	A80

TENSIONER- / HANG UP- / CARTRIDGE UNITS

T2	A84
T3	A88
T2 + WB	A92
SP2	A96
SPR	A100
C2	A102
C3	A106
EHE2	A110

PRESSED STEEL UNITS

PRESSED STEEL HOUSINGS WITH CHROME STEEL BEARING INSERTS

PILLOW BLOCK UNITS

PP2	A114
-----	------

FLANGED UNITS

PF2	A116
PFL2	A118
PFT2	A120

TAKE-UP UNITS

PFE2	A120
------	------

BEARING INSERTS (METRIC)

CHROME STEEL BEARING INSERTS WITH SPHERICAL OUTER RING

ECCENTRIC LOCKING COLLAR TYPES

EX2..G2, EX3..G2	A122
EX2..G2L3, EX3..G2L3,	
EX2..G2L4, EX2..AGR, EX3..AGR	A126
EX2..G2T04, EX3..G2T04, ES2..G2T04	A128
EX2..G2T20, ES2..G2T20	A132
ES2..G1N	A134

SET SCREW TYPES

UC2..G2, US2..G2, UCX..G2, UC3..G2	A136
UC2..G2L3, UC3..G2L3, UC2..G2L4,	
UC2..AGR, UC3..AGR	A140
UC2..G2T04, UC3..G2T04, US2..G2T04	A142
UC2..G2T20, US2..G2T20	A146
US2..G1N	A148

ADAPTER SLEEVE TYPES INCLUDED SLEEVES

UK2..G2H, LK2..G2H, UK3..G2H	A150
------------------------------	------

INTERFERENCE FIT TYPES

CS2	A152
-----	------

CHROME STEEL BEARING INSERTS WITH CYLINDRICAL OUTER RING

ECCENTRIC LOCKING COLLAR TYPES

CEX2, CES2	A154
------------	------

SET SCREW TYPES

CUC2, CUS2	A154
------------	------

BEARING INSERTS (INCH)

CHROME STEEL BEARING INSERTS WITH SPHERICAL OUTER RING

ECCENTRIC LOCKING COLLAR TYPES

EX2..G2, ES2..G2, EX3..G2	A156
EX2..G2L3, EX2..G2L4	A160
EX2..G2T04, EX3..G2T04, ES2..G2T04	A164
EX2..G2T20, ES2..G2T20	A168

SET SCREW TYPES

UC2..G2, US2..G2, UCX..G2, UC3..G2	A172
UC2..G2L3	A176
UC2..G2T04, UC3..G2T04, US2..G2T04	A178
UC2..G2T20	A182

ADAPTER SLEEVE TYPES INCLUDED SLEEVES

UK2..G2H	A184
----------	------

CHROME STEEL BEARING INSERTS WITH CYLINDRICAL OUTER RING

ECCENTRIC LOCKING COLLAR TYPES

CEX2, CES2	A188
------------	------

SET SCREW TYPES1

CUC2, CUS2	A188
------------	------

STAINLESS STEEL UNITS

STAINLESS STEEL HOUSINGS WITH STAINLESS STEEL BEARING INSERTS

PILLOW BLOCK UNITS

SP2	A192
SPA2	A194

FLANGED UNITS

SF2	A196
SFL2	A198
SFB2	A200

TENSIONER UNITS

ST2	A202
-----	------

THERMOPLASTIC UNITS

THERMOPLASTIC HOUSINGS WITH STAINLESS STEEL BEARING INSERTS

PILLOW BLOCK UNITS

PPL2, TBL2	A204
------------	------

FLANGED UNITS

FPL2, NFL2, FBL2	A206
------------------	------

BEARING INSERTS - FOOD SERIES

BEARING INSERTS FOR FOOD-PROCESSING

METRIC

SUC2, SUC2..FG1, MUC2..FD, ZUC2..FG, SES2	A210
---	------

INCH

SUC2, SUC2..FG1, MUC2..FD, ZUC2..FG, SES2	A212
---	------

COVERS / CAPS

PROTECTIVE COVERS AND PROTECTIVE CAPS

PROTECTIVE COVERS

SCO / SCC, SCOE / SCCE	A216
SCOU	A217

PROTECTIVE CAPS

PCO / PCC, CV / CF	A217
--------------------	------

CAST IRON HOUSINGS WITH CHROME STEEL BEARING INSERTS

PILLOW BLOCK UNITS

Pillow block regular design
PLE2

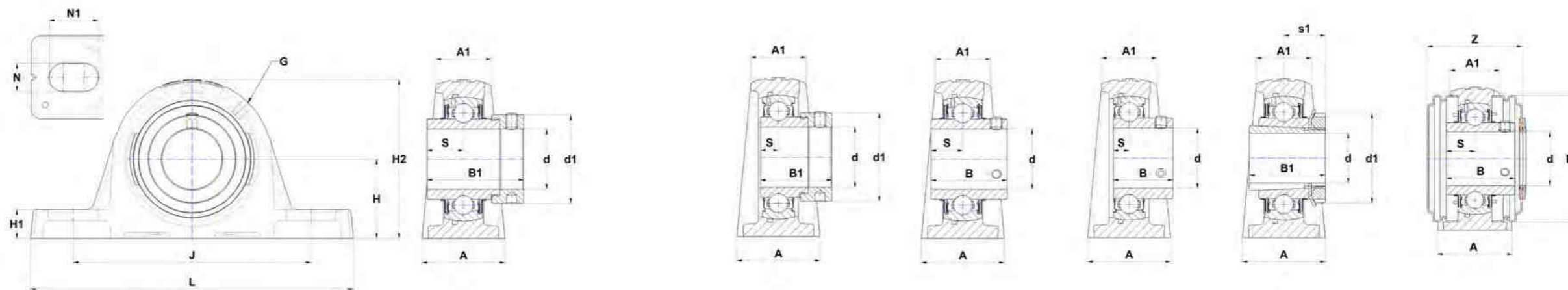

Main dimensions [mm]

d	Unit	L	J	H	H1	H2	A	A1	N	N1	S	s1	B	B1	d1	G	Z	Dz	Housing	Bearing insert	Adapter sleeve reference	Open protective cap*	Closed protective cap*	Dynamic load rating C [kN]	Static load rating C0 [kN]	Weight [kg]	d
45	ESPLE209	197,5	151,5	52,4	18,4	106,4	54	35	14	24	11	-	30,2	43,7	62	M6x1	85,5	95	PLE209	ES209G2	-	SCOE209-45	SCCE209	31,9	20,8	2,4	45
	EXPLE209	197,5	151,5	52,4	18,4	106,4	54	35	14	24	21,4	-	42,8	56,3	62	M6x1	85,5	95	PLE209	EX209G2	-	SCOE209-45	SCCE209	31,9	20,8	2,6	
	UCPLE209	197,5	151,5	52,4	18,4	106,4	54	35	14	24	19	-	49,2	-	-	M6x1	71,3	95	PLE209	UC209G2	-	SC0209-45	SCC209	31,9	20,8	2,4	
	UKPLE210H	214	164	55,6	19,3	114	55	36	14	27	-	27,5	31	55	70	M6x1	77,1	100	PLE210	UK210G2H	H2310	SC0210-45	SCC210	35,1	23,2	3,1	
	USPLE209	197,5	151,5	52,4	18,4	106,4	54	35	14	24	10,2	-	41,2	-	-	M6x1	71,3	95	PLE209	US209G2	-	SC0209-45	SCC209	31,9	20,8	2,4	
50	ESPLE210	214	164	55,6	19,3	114	55	36	14	27	11	-	30,2	43,7	67,2	M6x1	92,5	100	PLE210	ES210G2	-	SCOE210-50	SCCE210	35,1	23,2	2,9	50
	EXPLE210	214	164	55,6	19,3	114	55	36	14	27	24,6	-	49,2	62,7	67,2	M6x1	92,5	100	PLE210	EX210G2	-	SCOE210-50	SCCE210	35,1	23,2	3,1	
	UCPLE210	214	164	55,6	19,3	114	55	36	14	27	19	-	51,6	-	-	M6x1	77,1	100	PLE210	UC210G2	-	SC0210-50	SCC210	35,1	23,2	2,9	
	UKPLE211H	219,5	170,5	61,3	23,2	128	60	39,5	18	26	-	29	33	59	75	M6x1	78,9	110	PLE211	UK211G2H	H2311	SC0211-50	SCC211	43,6	29,2	4,0	
	USPLE210	214	164	55,6	19,3	114	55	36	14	27	10,9	-	43,5	-	-	M6x1	77,1	100	PLE210	US210G2	-	SC0210-50	SCC210	35,1	23,2	2,9	
55	ESPLE211	219,5	170,5	61,3	23,2	128	60	39,5	18	26	12	-	32,5	48,4	74,5	M6x1	105,7	110	PLE211	ES211G2	-	SCOE211-55	SCCE211	43,6	29,2	3,7	55
	EXPLE211	219,5	170,5	61,3	23,2	128	60	39,5	18	26	27,7	-	55,4	71,3	74,5	M6x1	105,7	110	PLE211	EX211G2	-	SCOE211-55	SCCE211	43,6	29,2	4,2	
	UCPLE211	219,5	170,5	61,3	23,2	128	60	39,5	18	26	22,2	-	55,6	-	-	M6x1	78,9	110	PLE211	UC211G2	-	SC0211-55	SCC211	43,6	29,2	3,9	
	UKPLE212H	245	193,7	68,3	28,6	138,1	79,4	50,8	18	29,1	-	31	36	62	80	M6x1	96,4	120	PLE212	UK212G2H	H2312	SC0212-55	SCC212	52,5	32,8	5,8	
	USPLE211	219,5	170,5	61,3	23,2	128	60	39,5	18	26	11,8	-	45,3	-	-	M6x1	78,9	110	PLE211	US211G2	-	SC0211-55	SCC211	43,6	29,2	3,9	
60	ESPLE212	245	193,7	68,3	28,6	138,1	79,4	50,8	18	29,1	12	-	33,4	49,3	82	M6x1	117,6	120	PLE212	ES212G2	-	SCOE212-60	SCCE212	52,5	32,8	5,5	60
	EXPLE212	245	193,7	68,3	28,6	138,1	79,4	50,8	18	29,1	30,9	-	61,8	77,7	82	M6x1	117,6	120	PLE212	EX212G2	-	SCOE212-60	SCCE212	52,5	32,8	6,2	
	UCPLE212	245	193,7	68,3	28,6	138,1	79,4	50,8	18	29,1	25,4	-	65,1	-	-	M6x1	96,4	120	PLE212	UC212G2	-	SC0212-60	SCC212	52,5	32,8	5,8	
	USPLE212	245	193,7	68,3	28,6	138,1	79,4	50,8	18	29,1	14,9	-	53,7	-	-	M6x1	96,4	120	PLE212	US212G2	-	SC0212-60	SCC212	52,5	32,8	5,6	

* Bearing units that are ordered with cover(s) include the housings with grooves.
If you want to install the protective covers later, housings with suffix N must be ordered (for example: P210N).

CAST IRON HOUSINGS WITH CHROME STEEL BEARING INSERTS

PILLOW BLOCK UNITS

Pillow block regular design,
heavy duty **P3**
medium duty **PEX**

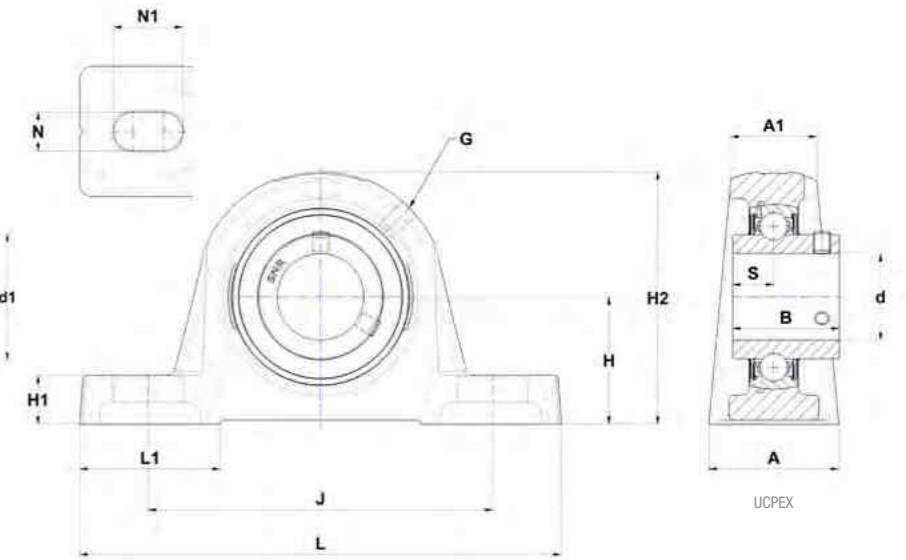
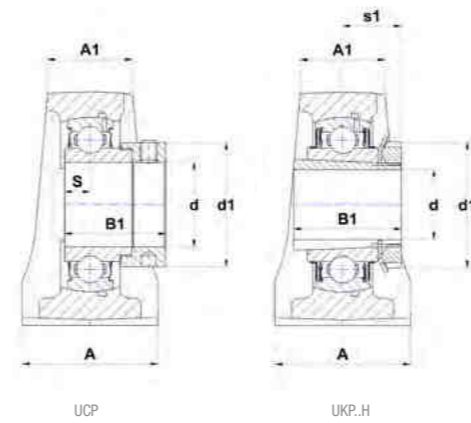
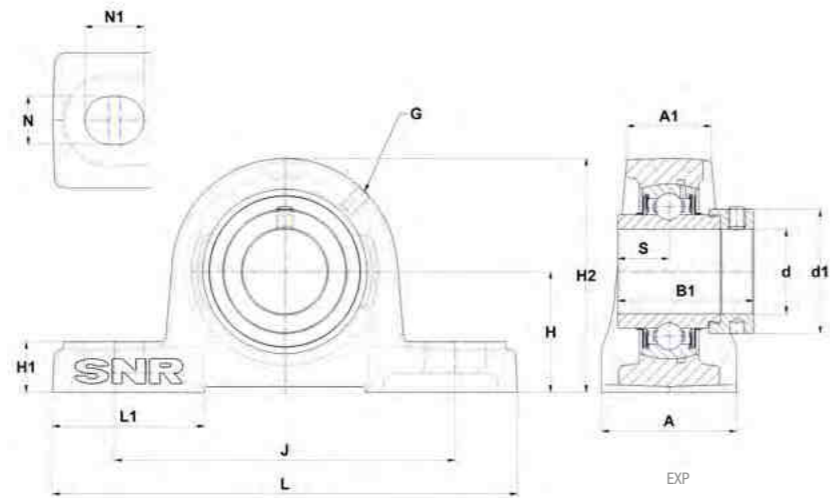

Main dimensions [mm]

d	Unit	L	J	H	H1	H2	A	A1	N	N1	L1	S	s1	B	B1	d1	G	Housing	Bearing insert	Adapter sleeve reference	Dynamic load rating C [kN]	Static load rating C0 [kN]	Weight [kg]	d
20	UKP305H	175	132	45	15	85	45	32	17	20	54	-	21,5	27	35	38	M6x1	P305	UK305G2H	H2305	22,4	11,5	1,6	20
25	EXP305	175	132	45	15	85	45	32	17	20	54	16,7	-	34,9	46,8	42,8	M6x1	P305	EX305G2	-	22,4	11,5	1,5	25
	UCP305	175	132	45	15	85	45	32	17	20	54	15	-	38	-	-	M6x1	P305	UC305G2	-	22,4	11,5	1,5	25
	UKP306H	180	140	50	18	95	50	36	17	20	54	-	23	30	38	45	M6x1	P306	UK306G2H	H2306	27,0	15,2	2,0	30
	EXP306	180	140	50	18	95	50	36	17	20	54	17,5	-	36,5	50	50	M6x1	P306	EX306G2	-	27,0	15,2	2,1	30
30	UCP306	180	140	50	18	95	50	36	17	20	54	17	-	43	-	-	M6x1	P306	UC306G2	-	27,0	15,2	2,0	30
	UKP307H	210	160	56	20	106	56	38	17	25	60	-	25,5	33	43	52	M6x1	P307	UK307G2H	H2307	33,5	19,2	2,8	35
	EXP307	210	160	56	20	106	56	38	17	25	60	18,3	-	38,1	51,6	55	M6x1	P307	EX307G2	-	33,5	19,2	2,7	35
	UCP307	210	160	56	20	106	56	38	17	25	60	19	-	48	-	-	M6x1	P307	UC307G2	-	33,5	19,2	2,6	35
35	UKP308H	220	170	60	22	116	60	42	17	27	60	-	27,5	35	46	58	M6x1	P308	UK308G2H	H2308	40,6	24,0	3,4	40
	EXP308	220	170	60	22	116	60	42	17	27	60	19,8	-	41,3	57,1	63,5	M6x1	P308	EX308G2	-	40,6	24,0	3,5	40
	UCP308	220	170	60	22	116	60	42	17	27	60	19	-	52	-	-	M6x1	P308	UC308G2	-	40,6	24,0	3,4	40
	UCPEX08	222,2	159	58,7	22,5	116,7	60	39,8	18	32	65	19	-	49,2	-	-	R1/8"	PEX08	UCX08G2	-	31,9	20,8	3,4	40
40	UKP309H	245	190	67	24	129	67	45	20	30	65	-	30	38	50	65	M6x1	P309	UK309G2H	H2309	53,0	31,8	4,8	45
	EXP309	245	190	67	24	129	67	45	20	30	65	19,8	-	42,9	58,7	70	M6x1	P309	EX309G2	-	53,0	31,8	4,8	45
	UCP309	245	190	67	24	129	67	45	20	30	65	22	-	57	-	-	M6x1	P309	UC309G2	-	53,0	31,8	4,6	45
	UCPEX09	222,2	159	58,7	22,5	116,7	60	39,8	18	32	65	19	-	51,6	-	-	R1/8"	PEX09	UCX09G2	-	35,1	23,2	3,3	45
45	UKP310H	275	212	75	27	143	75	48	20	35	75	-	32	40	55	70	M6x1	P310	UK310G2H	H2310	62,0	37,8	6,2	50
	EXP310	275	212	75	27	143	75	48	20	35	75	24,6	-	49,2	66,6	76,2	M6x1	P310	EX310G2	-	62,0	37,8	6,4	50
	UCP310	275	212	75	27	143	75	48	20	35	75	22	-	61	-	-	M6x1	P310	UC310G2	-	62,0	37,8	6,2	50
	UCPEX10	219,5	170,5	63,5	24,8	129,5	60	39,8	18	26	71	22,2	-	55,6	-	-	R1/8"	PEX10	UCX10G2	-	43,6	29,2	4,1	50
50	UKP311H	310	236	80	30	154	80	51	20	38	85	-	34	43	59	75	M6x1	P311	UK311G2H	H2311	71,5	44,8	7,8	55
	EXP311	310	236	80	30	154	80	51	20	38	85	27,8	-	55,6	73	83	M6x1	P311	EX311G2	-	71,5	44,8	7,9	55
	UCP311	310	236	80	30	154	80	51	20	38	85	25	-	66	-	-	M6x1	P311	UC311G2	-	71,5	44,8	7,5	55
	UCPEX11	249,5	190	69,9	26,2	142,2	69,5	44,3	22	33	72	25,4	-	65,1	-	-	R1/8"	PEX11	UCX11G2	-	52,5	32,8	5,5	55
55	UKP312H	330	250	85	32	165	85	54	25	38	95	-	36,5	47	62	80	M6x1	P312	UK312G2H	H2312	81,6	51,8	9,4	60
	EXP312	330	250	85	32	165	85	54	25	38	95	31	-	61,9	79,4	89	M6x1	P312	EX312G2	-	81,6	51,8	9,8	60
	UCP312	330	250	85	32	165	85	54	25	38	95	26	-	71	-	-	M6x1	P312	UC312G2	-	81,6	51,8	9,5	60
	UCPEX12	266	207	76,2	27	153	72	47,4	22	39,5	76	30,2	-	74,6	-	-	R1/8"	PEX12	UCX12G2	-	62,0	45,0	6,8	60
60	UKP313H	340	260	90	33	176	90	57	25	38	105	-	38,5	49	65	85	M6x1	P313	UK313G2H	H2313	93,9	60,5	11,2	65
	EXP313	340	260	90	33	176	90	57	25	38	105	32,5	-	65,1	85,7	97	M6x1	P313	EX313G2	-	93,9	60,5	11,6	65
	UCP313	340	260	90	33	176	90	57	25	38	105	30	-	75	-	-	M6x1	P313	UC313G2	-	93,9	60,5	11,2	65
	UCPEX13	330,2	230,8	88,9	28,6	177,8	88,9	67	26	50,7	92	33,3	-	77,8	-	-	R1/8"	PEX13-14	UCX13G2	-	66,0	49,5	11,2	65
65	UKP315H	380	290	100	35	198	100	63	27	40	110	-	42,5	55	73	98	M10x1	P315	UK315G2H	H2315	113,4	76,8	15,1	65

CAST IRON HOUSINGS WITH CHROME STEEL BEARING INSERTS

PILLOW BLOCK UNITS

Pillow block regular design,
heavy duty **P3**
medium duty **PEX**

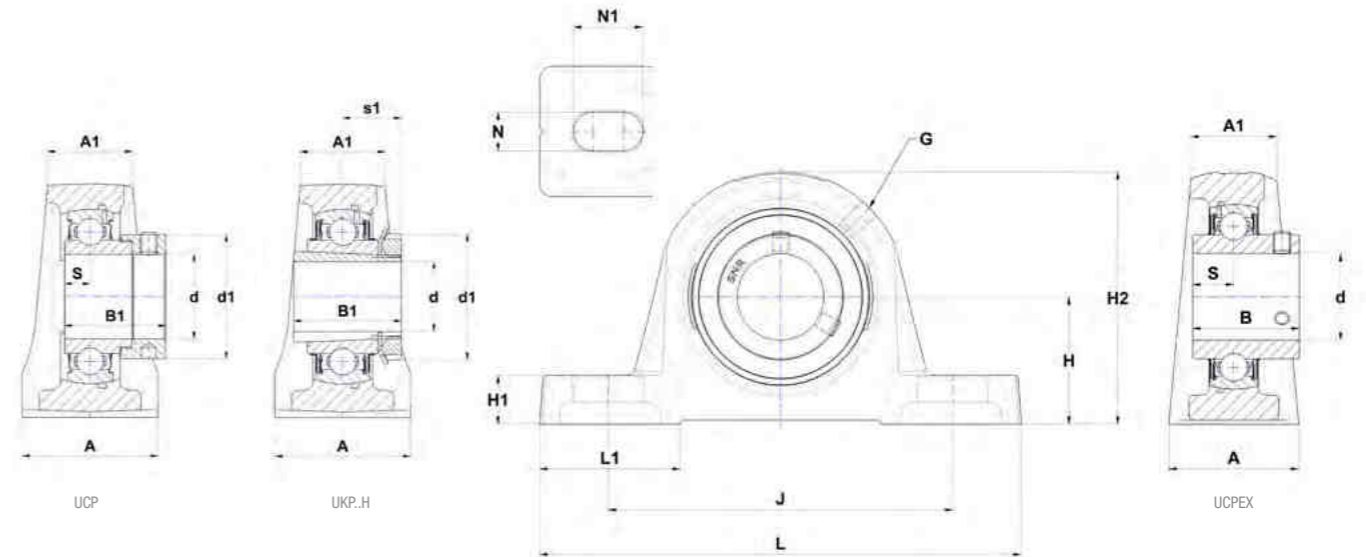
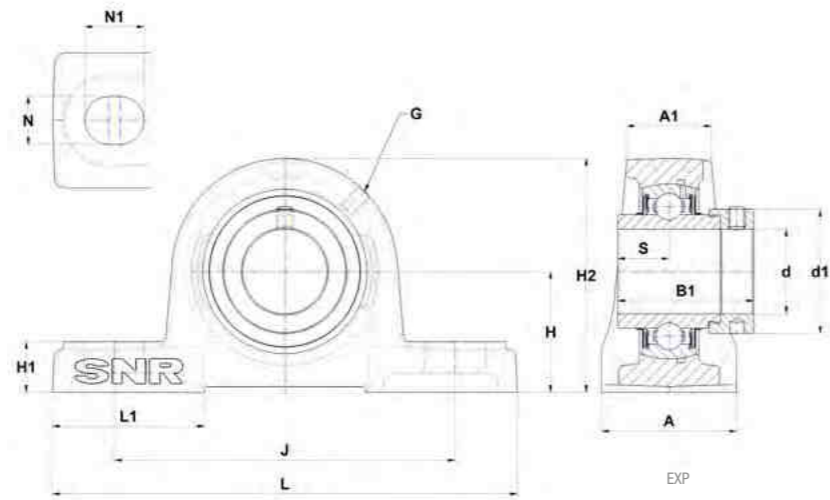

Main dimensions [mm]

d	Unit	L	J	H	H1	H2	A	A1	N	N1	L1	S	s1	B	B1	d1	G	Housing	Bearing insert	Adapter sleeve reference	Dynamic load rating C [kN]	Static load rating C0 [kN]	Weight [kg]	d
70	EXP314	360	280	95	35	187	90	60	27	40	105	34,2	-	68,3	92,1	102	M10x1	P314	EX314G2	-	104,3	68,0	13,5	70
	UCP314	360	280	95	35	187	90	60	27	40	105	33	-	78	-	-	M10x1	P314	UC314G2	-	104,3	68,0	13,0	
	UCPEX14	330,2	230,8	88,9	28,6	177,8	88,9	67	26	50,7	92	33,3	-	77,8	-	-	R1/8"	PEX13-14	UCX14G2	-	66,0	49,5	10,9	
	UKP316H	400	300	106	40	210	110	66	27	40	110	-	44,5	55	78	105	M10x1	P316	UK316G2H	H2316	122,9	86,5	19,1	
75	EXP315	380	290	100	35	198	100	63	27	40	110	37,3	-	74,6	100	113	M10x1	P315	EX315G2	-	113,4	76,8	15,4	75
	UCP315	380	290	100	35	198	100	63	27	40	110	32	-	82	-	-	M10x1	P315	UC315G2	-	113,4	76,8	14,4	
	UCPEX15	330,2	241,8	88,9	31,8	184,3	88,9	67	26	39,8	96	33,3	-	82,6	-	-	R1/8"	PEX15	UCX15G2	-	72,5	54,2	11,9	
	UKP317H	420	320	112	40	220	110	69	33	45	120	-	48	60	82	110	M10x1	P317	UK317G2H	H2317	132,6	96,5	21,3	
80	EXP316	400	300	106	40	210	110	66	27	40	110	40,5	-	81	106,4	119	M10x1	P316	EX316G2	-	122,9	86,5	20,0	80
	UCP316	400	300	106	40	210	110	66	27	40	110	34	-	86	-	-	M10x1	P316	UC316G2	-	122,9	86,5	18,9	
	UCPEX16	381	288,8	101,6	31,8	203,7	101,8	68,8	27	55,7	105	34,1	-	85,7	-	-	R1/8"	PEX16	UCX16G2	-	83,2	63,8	16,1	
	UKP318H	430	330	118	45	235	110	72	33	45	120	-	48	60	86	120	M10x1	P318	UK318G2H	H2318	143,0	108,0	25,0	
85	EXP317	420	320	112	40	220	110	69	33	45	120	42	-	84,1	109,5	127	M10x1	P317	EX317G2	-	132,6	96,5	22,4	85
	UCP317	420	320	112	40	220	110	69	33	45	120	40	-	96	-	-	M10x1	P317	UC317G2	-	132,6	96,5	21,2	
	UKP319H	470	360	125	45	250	120	75	36	50	125	-	52	66	90	125	M10x1	P319	UK319G2H	H2319	156,0	122,0	30,6	
90	EXP318	430	330	118	45	235	110	72	33	45	120	43,6	-	87,3	115,9	133	M10x1	P318	EX318G2	-	143,0	108,0	26,2	90
	UCP318	430	330	118	45	235	110	72	33	45	120	40	-	96	-	-	M10x1	P318	UC318G2	-	143,0	108,0	25,0	
	UKP320H	490	380	140	50	275	120	81	36	50	130	-	54	68	97	130	M10x1	P320	UK320G2H	H2320	171,6	140,0	37,7	
95	EXP319	470	360	125	45	250	120	75	36	50	125	46,8	-	93,7	122,3	140	M10x1	P319	EX319G2	-	156,0	122,0	31,8	95
	UCP319	470	360	125	45	250	120	75	36	50	125	41	-	103	-	-	M10x1	P319	UC319G2	-	156,0	122,0	30,3	
100	EXP320	490	380	140	50	275	120	81	36	50	130	50	-	100	128,6	146	M10x1	P320	EX320G2	-	171,6	140,0	39,7	100
	UCP320	492	380	140	50	275	120	81	36	50	130	42	54	108	-	-	M10x1	P320	UC320G2	-	171,6	140,0	37,9	
	UKP322H	520	400	150	55	300	140	83	40	55	135	-	61	80	105	145	M10x1	P322	UK322G2H	H2322	205,0	178,0	51,0	
105	UCP321	490	380	140	50	280	120	80	36	50	130	44	-	112	-	-	M10x1	P321	UC321G2	-	182,0	155,0	38,3	105
110	UCP322	520	400	150	55	300	140	83	40	55	135	46	-	117	-	-	M10x1	P322	UC322G2	-	205,0	178,0	47,7	110
	UKP324H	570	450	160	65	320	140	88	40	55	140	-	65,5	87	112	155	M10x1	P324	UK324G2H	H2324	228,0	208,0	61,2	
115	UKP326H	600	480	180	75	355	140	94	40	55	140	-	68	90	121	165	M10x1	P326	UK326G2H	H2326	252,0	242,0	79,5	115
120	UCP324	570	450	160	65	320	140	88	40	55	140	51	-	126	-	-	M10x1	P324	UC324G2	-	228,0	208,0	58,5	120
125	UKP328H	620	500	200	75	390	140	92	40	55	140	-	73	98	131	180	M10x1	P328	UK328G2H	H2328	275,0	272,0	95,9	125
130	UCP326	600	480	180	75	355	140	94	40	55	140	54	-	135	-	-	M10x1	P326	UC326G2	-	252,0	242,0	74,6	130
140	UCP328	620	500	200	75	390	140	92	40	55	140	59	-	145	-	-	M10x1	P328	UC328G2	-	275,0	272,0	89,9	140

Summary

CAST IRON HOUSINGS WITH CHROME STEEL BEARING INSERTS

PILLOW BLOCK UNITS

Tapped base pillow block
PAE2

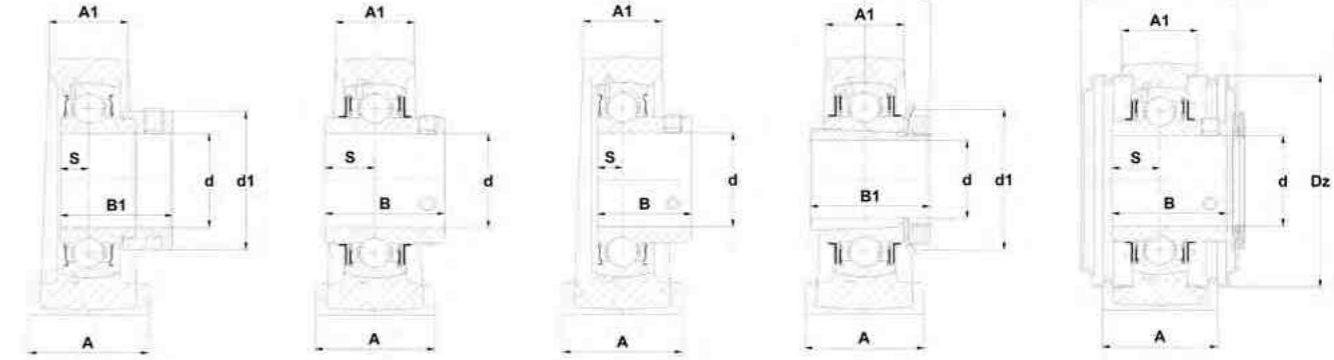
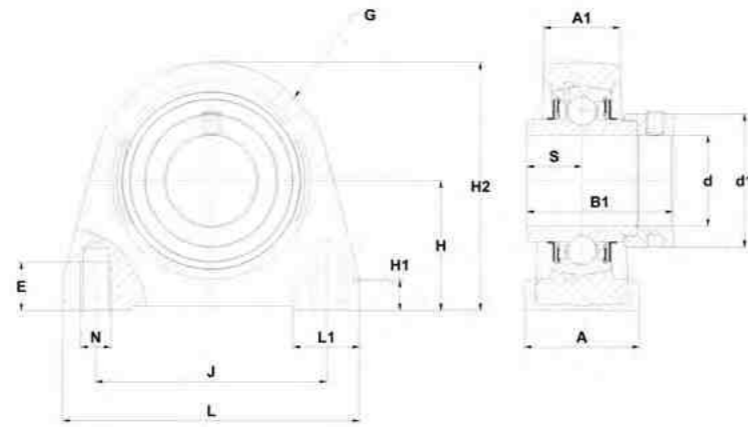

Main dimensions [mm]

d	Unit	L	J	H	H1	H2	A	A1	N	E	L1	S	s1	s1	B1	d1	G	Z	Dz	Housing	Bearing insert	Adapter sleeve reference	Open protective cap*	Closed protective cap*	Dynamic load rating C [kN]	Static load rating CO [kN]	Weight [kg]	d
12	ESPAE201	63	47	30,2	9	57	30	18	M8	10	17,5	6,5	-	19	28,6	27,2	M6x1	57,9	46	PAE203	ES201G2	-	SCOE201-12	SCCE203	9,6	4,8	0,4	12
	EXPAE201	65	50,8	33,3	9	64	32	19	M8	10	18	17	-	34	43,5	32,4	R1/8"	62,9	54	PAE204	EX201G2	-	SCOE204-12	SCCE204	12,8	6,7	0,6	
	UCPAE201	65	50,8	33,3	9	64	32	19	M8	10	18	12,7	-	31	-	-	R1/8"	44,5	54	PAE204	UC201G2	-	SCO204-12	SCC204	12,8	6,7	0,5	
	USPAE201	63	47	30,2	9	57	30	18	M8	10	17,5	6	-	22	-	-	M6x1	44,5	46	PAE203	US201G2	-	SCO201-12	SCC203	9,6	4,8	0,4	
15	ESPAE202	63	47	30,2	9	57	30	18	M8	10	17,5	6,5	-	19,1	28,6	27,2	M6x1	57,9	46	PAE203	ES202G2	-	SCOE202-15	SCCE203	9,6	4,8	0,4	15
	EXPAE202	65	50,8	33,3	9	64	32	19	M8	10	18	17	-	34	43,5	32,4	R1/8"	62,9	54	PAE204	EX202G2	-	SCOE204-15	SCCE204	12,8	6,7	0,6	
	UCPAE202	65	50,8	33,3	9	64	32	19	M8	10	18	12,7	-	31	-	-	R1/8"	44,5	54	PAE204	UC202G2	-	SCO204-15	SCC204	12,8	6,7	0,5	
	USPAE202	63	47	30,2	9	57	30	18	M8	10	17,5	6	-	22	-	-	M6x1	44,5	46	PAE203	US202G2	-	SCO202-15	SCC203	9,6	4,8	0,4	
17	ESPAE203	63	47	30,2	9	57	30	18	M8	10	17,5	6,5	-	19,1	28,6	27,2	M6x1	57,9	46	PAE203	ES203G2	-	SCOE203-17	SCCE203	9,6	4,8	0,4	17
	EXPAE203	65	50,8	33,3	9	64	32	19	M8	10	18	17	-	34	43,5	32,4	R1/8"	62,9	54	PAE204	EX203G2	-	SCOE204-17	SCCE204	12,8	6,7	0,6	
	UCPAE203	65	50,8	33,3	9	64	32	19	M8	10	18	12,7	-	31	-	-	R1/8"	44,5	54	PAE204	UC203G2	-	SCO204-17	SCC204	12,8	6,7	0,5	
	USPAE203	63	47	30,2	9	57	30	18	M8	10	17,5	6	-	22	-	-	M6x1	44,5	46	PAE203	US203G2	-	SCO203-17	SCC203	9,6	4,8	0,4	
20	ESPAE204	65	50,8	33,3	9	64	32	19	M8	10	18	7,5	-	21,4	30,9	32,4	R1/8"	62,9	54	PAE204	ES204G2	-	SCOE204-20	SCCE204	12,8	6,7	0,5	20
	EXPAE204	65	50,8	33,3	9	64	32	19	M8	10	18	17	-	34	43,5	32,4	R1/8"	62,9	54	PAE204	EX204G2	-	SCOE204-20	SCCE204	12,8	6,7	0,5	
	UCPAE204	65	50,8	33,3	9	64	32	19	M8	10	18	12,7	-	31	-	-	R1/8"	44,5	54	PAE204	UC204G2	-	SCO204-20	SCC204	12,8	6,7	0,5	
	UKPAE205H	70	50,8	36,5	10	70	36	21	M10	12,5	21	-	18,5	21	35	38	R1/8"	47,3	60	PAE205	UK205G2H	H2305	SCO205-20	SCC205	14,0	7,9	0,6	
	USPAE204	65	50,8	33,3	9	64	32	19	M8	10	18	7	-	25	-	-	R1/8"	44,5	54	PAE204	US204G2	-	SCO204-20	SCC204	12,8	6,7	0,4	
25	ESPAE205	70	50,8	36,5	10	70	36	21	M10	12,5	21	7,5	-	21,4	30,9	37,4	R1/8"	64,5	60	PAE205	ES205G2	-	SCOE205-25	SCCE205	14,0	7,9	0,6	25
	EXPAE205	70	50,8	36,5	10	70	36	21	M10	12,5	21	17,4	-	34,8	44,3	37,4	R1/8"	64,5	60	PAE205	EX205G2	-	SCOE205-25	SCCE205	14,0	7,9	0,7	
	UCPAE205	70	50,8	36,5	10	70	36	21	M10	12,5	21	14,3	-	34	-	-	R1/8"	47,3	60	PAE205	UC205G2	-	SCO205-25	SCC205	14,0	7,9	0,6	
	UKPAE206H	98	76,2	42,9	11	82	38	25	M10	12,5	22	-	20,5	25	38	45	R1/8"	52,3	70	PAE206	UK206G2H	H2306	SCO206-25	SCC206	19,5	11,2	1,0	
	USPAE205	70	50,8	36,5	10	70	36	21	M10	12,5	21	7,5	-	27	-	-	R1/8"	47,3	60	PAE205	US205G2	-	SCO205-25	SCC205	14,0	7,9	0,6	
30	ESPAE206	98	76,2	42,9	11	82	38	25	M10	12,5	22	9	-	23,8	35,7	44,1	R1/8"	70,5	70	PAE206	ES206G2	-	SCOE206-30	SCCE206	19,5	11,2	0,9	30
	EXPAE206	98	76,2	42,9	11	82	38	25	M10	12,5	22	18,2	-	36,4	48,3	44,1	R1/8"	70,5	70	PAE206	EX206G2	-	SCOE206-30	SCCE206	19,5	11,2	1,0	
	UCPAE206	98	76,2	42,9	11	82	38	25	M10	12,5	22	15,9	-	38,1	-	-	R1/8"	52,3	70	PAE206	UC206G2	-	SCO206-30	SCC206	19,5	11,2	0,9	
	UKPAE207H	103	82,6	47,6	12	93	45	27	M10	12,5	22,5	-	22,5	27	43	52	R1/8"	58,9	80	PAE207	UK207G2H	H2307	SCO207-30	SCC207	25,7	15,2	1,4	
	USPAE206	98	76,2	42,9	11	82	38	25	M10	12,5	22	8	-	30	-	-	R1/8"	52,3	70	PAE206	US206G2	-	SCO206-30	SCC206	19,5	11,2	0,9	
35	ESPAE207	103	82,6	47,6	12	93	45	27	M10	12,5	22,5	9,5	-	25,4	38,9	51,1	R1/8"	77,5	80	PAE207	ES207G2	-	SCOE207-35	SCCE207	25,7	15,2	1,4	35
	EXPAE207	103	82,6	47,6	12	93	45	27	M10	12,5	22,5	18,8	-	37,6	51,1	51,1	R1/8"	77,5	80	PAE207	EX207G2	-	SCOE207-35	SCCE207	25,7	15,2	1,5	
	UCPAE207	103	82,6	47,6	12	93	45	27	M10	12,5	22,5	17,5	-	42,9	-	-	R1/8"	58,9	80	PAE207	UC207G2	-	SCO207-35	SCC207	25,7	15,2	1,4	
	UKPAE208H	116	88,9	49,2	13	99	47	30	M12	15	27	-	24,5	29	46	58	R1/8"	69,7	88	PAE208	UK208G2H	H2308	SCO208-35	SCC208	29,6	18,2	1,7	
	USPAE207	103	82,6	47,6	12	93	45	27	M10	12,5	22,5	8,5	-	32	-	-	R1/8"	58,9	80	PAE207	US207G2	-	SCO207-35	SCC207	25,7	15,2	1,3	

* Bearing units that are ordered with cover(s) include the housings with grooves.
If you want to install the protective covers later, housings with suffix N must be ordered (for example: P210N).

CAST IRON HOUSINGS WITH CHROME STEEL BEARING INSERTS

PILLOW BLOCK UNITS

Tapped base pillow block
PAE2

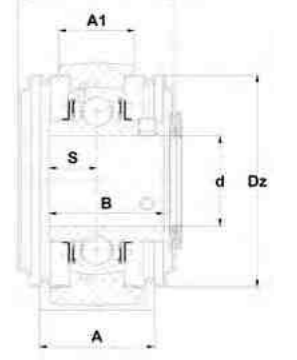
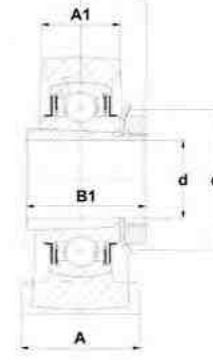
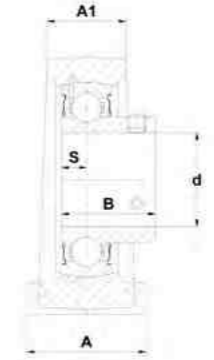
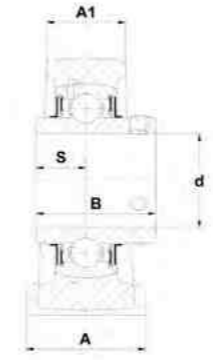
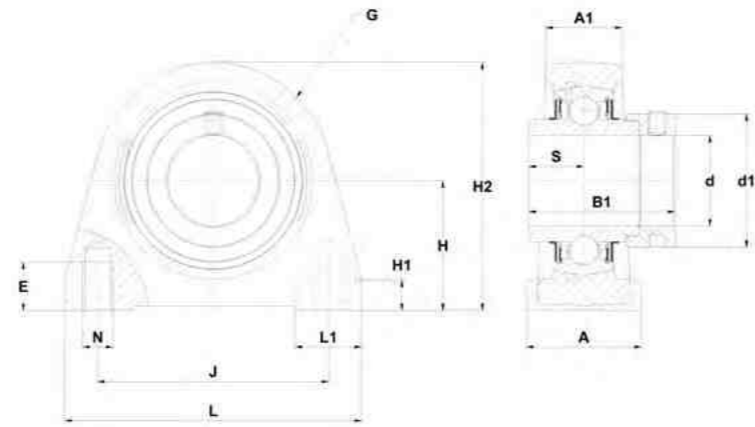

Main dimensions [mm]

d	Unit	L	J	H	H1	H2	A	A1	N	E	L1	S	s1	s1	B1	d1	G	Z	Dz	Housing	Bearing insert	Adapter sleeve reference	Open protective cap*	Closed protective cap*	Dynamic load rating C [kN]	Static load rating CO [kN]	Weight [kg]	d
40	ESPAE208	116	88,9	49,2	13	99	47	30	M12	15	27	11	-	30,2	43,7	58	R1/8"	81,9	88	PAE208	ES208G2	-	SCOE208-40	SCCE208	29,6	18,2	1,7	40
	EXPAE208	116	88,9	49,2	13	99	47	30	M12	15	27	21,4	-	42,8	56,3	58	R1/8"	81,9	88	PAE208	EX208G2	-	SCOE208-40	SCCE208	29,6	18,2	1,8	
	UCPAE208	116	88,9	49,2	13	99	47	30	M12	15	27	19	-	49,2	-	-	R1/8"	69,7	88	PAE208	UC208G2	-	SC0208-40	SCC208	29,6	18,2	1,6	
	UKPAE209H	120	95,3	53,9	14	107	48	32	M12	15	29	-	26	30	50	65	R1/8"	70,3	95	PAE209	UK209G2H	H2309	SC0209-40	SCC209	31,9	20,8	2,0	
	USPAE208	116	88,9	49,2	13	99	47	30	M12	15	27	9	-	34	-	-	R1/8"	69,7	88	PAE208	US208G2	-	SC0208-40	SCC208	29,6	18,2	1,6	
45	ESPAE209	120	95,3	53,9	14	107	48	32	M12	15	29	11	-	30,2	43,7	62	R1/8"	84,5	95	PAE209	ES209G2	-	SCOE209-45	SCCE209	31,9	20,8	1,9	45
	EXPAE209	120	95,3	53,9	14	107	48	32	M12	15	29	21,4	-	42,8	56,3	62	R1/8"	84,5	95	PAE209	EX209G2	-	SCOE209-45	SCCE209	31,9	20,8	2,1	
	UCPAE209	120	95,3	53,9	14	107	48	32	M12	15	29	19	-	49,2	-	-	R1/8"	70,3	95	PAE209	UC209G2	-	SC0209-45	SCC209	31,9	20,8	1,9	
	UKPAE210H	135	101,6	57,2	15	115	54	34	M16	20	33,5	-	27,5	31	55	70	R1/8"	76,1	100	PAE210	UK210G2H	H2310	SC0210-45	SCC210	35,1	23,2	2,7	
	USPAE209	120	95,3	53,9	14	107	48	32	M12	15	29	10,2	-	41,2	-	-	R1/8"	70,3	95	PAE209	US209G2	-	SC0209-45	SCC209	31,9	20,8	1,9	
50	ESPAE210	135	101,6	57,2	15	115	54	34	M16	20	33,5	11	-	30,2	43,7	67,2	R1/8"	91,5	100	PAE210	ES210G2	-	SCOE210-50	SCCE210	35,1	23,2	2,5	50
	EXPAE210	135	101,6	57,2	15	115	54	34	M16	20	33,5	24,6	-	49,2	62,7	67,2	R1/8"	91,5	100	PAE210	EX210G2	-	SCOE210-50	SCCE210	35,1	23,2	2,7	
	UCPAE210	135	101,6	57,2	15	115	54	34	M16	20	33,5	19	-	51,6	-	-	R1/8"	76,1	100	PAE210	UC210G2	-	SC0210-50	SCC210	35,1	23,2	2,5	
	UKPAE211H	150	118	64	16	125	60	35	M16	20	32	-	29	33	59	75	R1/8"	77,7	110	PAE211	UK211G2H	H2311	SC0211-50	SCC211	43,6	29,2	3,2	
	USPAE210	135	101,6	57,2	15	115	54	34	M16	20	33,5	10,9	-	43,5	-	-	R1/8"	76,1	100	PAE210	US210G2	-	SC0210-50	SCC210	35,1	23,2	2,5	
55	ESPAE211	150	118	64	16	125	60	35	M16	20	32	12	-	32,5	48,4	74,5	R1/8"	104,5	110	PAE211	ES211G2	-	SCOE211-55	SCCE211	43,6	29,2	2,9	55
	EXPAE211	150	118	64	16	125	60	35	M16	20	32	27,7	-	55,4	71,3	74,5	R1/8"	104,5	110	PAE211	EX211G2	-	SCOE211-55	SCCE211	43,6	29,2	3,4	
	UCPAE211	150	118	64	16	125	60	35	M16	20	32	22,2	-	55,6	-	-	R1/8"	77,7	110	PAE211	UC211G2	-	SC0211-55	SCC211	43,6	29,2	3,1	
	UKPAE212H	150	118	69,9	16	140	60	42	M16	20	32	-	31	36	62	80	R1/8"	91,3	120	PAE212	UK212G2H	H2312	SC0212-55	SCC212	52,5	32,8	4,2	
	USPAE211	150	118	64	16	125	60	35	M16	20	32	11,8	-	45,3	-	-	R1/8"	77,7	110	PAE211	US211G2	-	SC0211-55	SCC211	43,6	29,2	3,1	
60	ESPAE212	150	118	69,9	16	140	60	42	M16	20	32	12	-	33,4	49,3	82	R1/8"	112,5	120	PAE212	ES212G2	-	SCOE212-60	SCCE212	52,5	32,8	3,9	60
	EXPAE212	150	118	69,9	16	140	60	42	M16	20	32	30,9	-	61,8	77,7	82	R1/8"	112,5	120	PAE212	EX212G2	-	SCOE212-60	SCCE212	52,5	32,8	4,6	
	UCPAE212	150	118	69,9	16	140	60	42	M16	20	32	25,4	-	65,1	-	-	R1/8"	91,3	120	PAE212	UC212G2	-	SC0212-60	SCC212	52,5	32,8	4,2	
	USPAE212	150	118	69,9	16	140	60	42	M16	20	32	14,9	-	53,7	-	-	R1/8"	91,3	120	PAE212	US212G2	-	SC0212-60	SCC212	52,5	32,8	4,0	

* Bearing units that are ordered with cover(s) include the housings with grooves.
If you want to install the protective covers later, housings with suffix N must be ordered (for example: P210N).

CAST IRON HOUSINGS WITH CHROME STEEL BEARING INSERTS

PILLOW BLOCK UNITS

Tapped base pillow block PG2

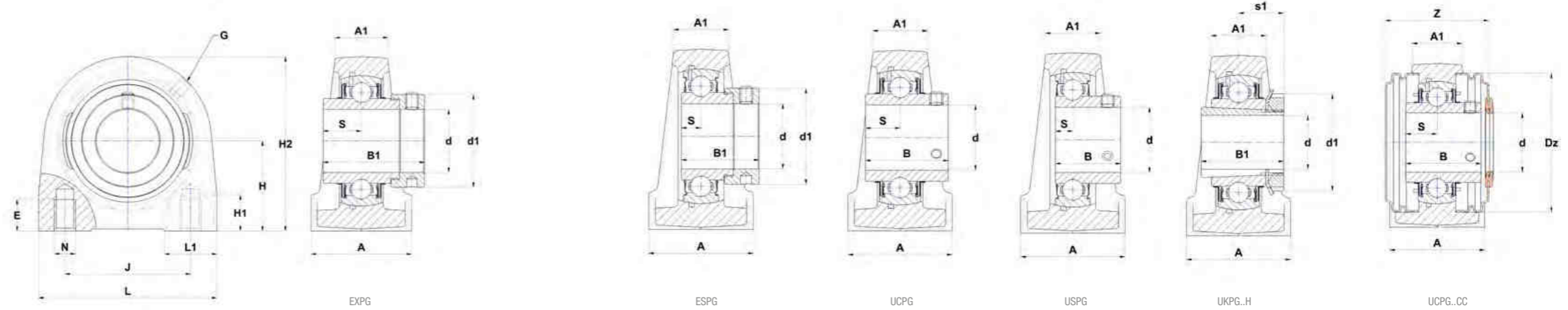

Main dimensions [mm]

d	Unit	L	J	H	H1	H2	A	A1	N	E	L1	S	s1	B	B1	d1	G	Z	Dz	Housing	Bearing insert	Adapter sleeve reference	Open protective cap*	Closed protective cap*	Dynamic load rating C [kN]	Static load rating CO [kN]	Weight [kg]	d
12	ESPG201	55	38	30,2	14	57	30	13	M6	15	17	6,5	-	19	28,6	27,2	M6x1	-	-	PG203	ES201G2	-	-	9,6	4,8	0,3	12	
	EXPG201	70	49	33,3	14	64	38	20	M8	16	21	17	-	34	43,5	32,4	M6x1	63,3	54	PG204	EX201G2	SCOE204-12	SCCE204	12,8	6,7	0,7		
	UCPG201	70	49	33,3	14	64	38	20	M8	16	21	12,7	-	31	-	-	M6x1	44,9	54	PG204	UC201G2	SC0204-12	SCC204	12,8	6,7	0,6		
	USPG201	55	38	30,2	14	57	30	13	M6	15	17	6	-	22	-	-	M6x1	-	-	PG203	US201G2	-	-	9,6	4,8	0,3		
15	ESPG202	55	38	30,2	14	57	30	13	M6	15	17	6,5	-	19,1	28,6	27,2	M6x1	-	-	PG203	ES202G2	-	-	9,6	4,8	0,3	15	
	EXPG202	70	49	33,3	14	64	38	20	M8	16	21	17	-	34	43,5	32,4	M6x1	63,3	54	PG204	EX202G2	SCOE204-15	SCCE204	12,8	6,7	0,7		
	UCPG202	70	49	33,3	14	64	38	20	M8	16	21	12,7	-	31	-	-	M6x1	44,9	54	PG204	UC202G2	SC0204-15	SCC204	12,8	6,7	0,6		
	USPG202	55	38	30,2	14	57	30	13	M6	15	17	6	-	22	-	-	M6x1	-	-	PG203	US202G2	-	-	9,6	4,8	0,3		
17	ESPG203	55	38	30,2	14	57	30	13	M6	15	17	6,5	-	19,1	28,6	27,2	M6x1	-	-	PG203	ES203G2	-	-	9,6	4,8	0,3	17	
	EXPG203	70	49	33,3	14	64	38	20	M8	16	21	17	-	34	43,5	32,4	M6x1	63,3	54	PG204	EX203G2	SCOE204-17	SCCE204	12,8	6,7	0,7		
	UCPG203	70	49	33,3	14	64	38	20	M8	16	21	12,7	-	31	-	-	M6x1	44,9	54	PG204	UC203G2	SC0204-17	SCC204	12,8	6,7	0,6		
	USPG203	55	38	30,2	14	57	30	13	M6	15	17	6	-	22	-	-	M6x1	-	-	PG203	US203G2	-	-	9,6	4,8	0,3		
20	ESPG204	70	49	33,3	14	64	38	20	M8	16	21	7,5	-	21,4	30,9	32,4	M6x1	63,3	54	PG204	ES204G2	-	-	12,8	6,7	0,6	20	
	EXPG204	70	49	33,3	14	64	38	20	M8	16	21	17	-	34	43,5	32,4	M6x1	63,3	54	PG204	EX204G2	SCOE204-20	SCCE204	12,8	6,7	0,6		
	UCPG204	70	49	33,3	14	64	38	20	M8	16	21	12,7	-	31	-	-	M6x1	44,9	54	PG204	UC204G2	SC0204-20	SCC204	12,8	6,7	0,6		
	UKPG205H	75	50	36,5	15	70	38	25	M10	18	25	-	18,5	21	35	38	M6x1	48,3	60	PG205	UK205G2H	H2305	SC0205-20	SCC205	14,0	7,9	0,7	
	USPG204	70	49	33,3	14	64	38	20	M8	16	21	7	-	25	-	-	M6x1	44,9	54	PG204	US204G2	SC0204-20	SCC204	12,8	6,7	0,5		
25	ESPG205	75	50	36,5	15	70	38	25	M10	18	25	7,5	-	21,4	30,9	37,4	M6x1	65,5	60	PG205	ES205G2	-	-	14,0	7,9	0,7	25	
	EXPG205	75	50	36,5	15	70	38	25	M10	18	25	17,4	-	34,8	44,3	37,4	M6x1	65,5	60	PG205	EX205G2	SCOE205-25	SCCE205	14,0	7,9	0,8		
	UCPG205	75	50	36,5	15	70	38	25	M10	18	25	14,3	-	34	-	-	M6x1	48,3	60	PG205	UC205G2	SC0205-25	SCC205	14,0	7,9	0,7		
	UKPG206H	85	60	42,9	17	83	48	25	M10	18	25	-	20,5	25	38	45	M6x1	52,3	70	PG206	UK206G2H	H2306	SC0206-25	SCC206	19,5	11,2	1,2	
	USPG205	75	50	36,5	15	70	38	25	M10	18	25	7,5	-	27	-	-	M6x1	48,3	60	PG205	US205G2	SC0205-25	SCC205	14,0	7,9	0,7		
30	ESPG206	85	60	42,9	17	83	48	25	M10	18	25	9	-	23,8	35,7	44,1	M6x1	70,5	70	PG206	ES206G2	-	-	19,5	11,2	1,1	30	
	EXPG206	85	60	42,9	17	83	48	25	M10	18	25	18,2	-	36,4	48,3	44,1	M6x1	70,5	70	PG206	EX206G2	SCOE206-30	SCCE206	19,5	11,2	1,2		
	UCPG206	85	60	42,9	17	83	48	25	M10	18	25	15,9	-	38,1	-	-	M6x1	52,3	70	PG206	UC206G2	SC0206-30	SCC206	19,5	11,2	1,1		
	UKPG207H	100	68	47,6	20	93	48	27	M12	22	35	-	22,5	27	43	52	M6x1	59,9	80	PG207	UK207G2H	H2307	SC0207-30	SCC207	25,7	15,2	1,6	
	USPG206	85	60	42,9	17	83	48	25	M10	18	25	8	-	30	-	-	M6x1	52,3	70	PG206	US206G2	SC0206-30	SCC206	19,5	11,2	1,1		
35	ESPG207	100	68	47,6	20	93	48	27	M12	22	35	9,5	-	25,4	38,9	51,1	M6x1	78,5	80	PG207	ES207G2	-	-	25,7	15,2	1,6	35	
	EXPG207	100	68	47,6	20	93	48	27	M12	22	35	18,8	-	37,6	51,1	51,1	M6x1	78,5	80	PG207	EX207G2	SCOE207-35	SCCE207	25,7	15,2	1,7		
	UCPG207	100	68	47,6	20	93	48	27	M12	22	35	17,5	-	42,9	-	-	M6x1	59,9	80	PG207	UC207G2	SC0207-35	SCC207	25,7	15,2	1,6		
	UKPG208H	110	78	49,2	20	98	54	30	M12	22	35	-	24,5	29	46	58	M6x1	69,3	88	PG208	UK208G2H	H2308	SC0208-35	SCC208	29,6	18,2	1,9	
	USPG207	100	68	47,6	20	93	48	27	M12	22	35	8,5	-	32	-	-	M6x1	59,9	80	PG207	US207G2	SC0207-35	SCC207	25,7	15,2	1,5		

* Bearing units that are ordered with cover(s) include the housings with grooves.
If you want to install the protective covers later, housings with suffix N must be ordered (for example: P210N).

CAST IRON HOUSINGS WITH CHROME STEEL BEARING INSERTS

PILLOW BLOCK UNITS

Tapped base pillow block PG2

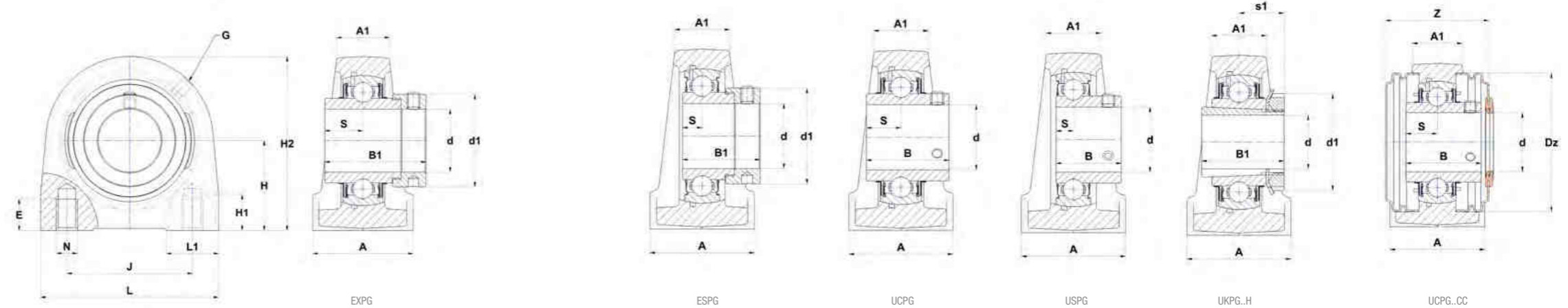

Main dimensions [mm]

d	Unit	L	J	H	H1	H2	A	A1	N	E	L1	S	s1	B	B1	d1	G	Z	Dz	Housing	Bearing insert	Adapter sleeve reference	Open protective cap*	Closed protective cap*	Dynamic load rating C [kN]	Static load rating CO [kN]	Weight [kg]	d
40	ESPG208	110	78	49,2	20	98	54	30	M12	22	35	11	-	30,2	43,7	58	M6x1	81,5	88	PG208	ES208G2		SCOE208-40	SCCE208	29,6	18,2	1,9	40
	EXPG208	110	78	49,2	20	98	54	30	M12	22	35	21,4	-	42,8	56,3	58	M6x1	81,5	88	PG208	EX208G2		SCOE208-40	SCCE208	29,6	18,2	2,0	
	UCPG208	110	78	49,2	20	98	54	30	M12	22	35	19	-	49,2	-	-	M6x1	69,3	88	PG208	UC208G2		SC0208-40	SCC208	29,6	18,2	1,8	
	UKPG209H	120	85	53,9	20	106	54	33	M12	22	40	-	26	30	50	65	M6x1	70,3	95	PG209	UK209G2H	H2309	SC0209-40	SCC209	31,9	20,8	2,3	
	USPG208	110	78	49,2	20	98	54	30	M12	22	35	9	-	34	-	-	M6x1	69,3	88	PG208	US208G2		SC0208-40	SCC208	29,6	18,2	1,8	
45	ESPG209	120	85	53,9	20	106	54	33	M12	22	40	11	-	30,2	43,7	62	M6x1	84,5	95	PG209	ES209G2		SCOE209-45	SCCE209	31,9	20,8	2,2	45
	EXPG209	120	85	53,9	20	106	54	33	M12	22	40	21,4	-	42,8	56,3	62	M6x1	84,5	95	PG209	EX209G2		SCOE209-45	SCCE209	31,9	20,8	2,4	
	UCPG209	120	85	53,9	20	106	54	33	M12	22	40	19	-	49,2	-	-	M6x1	70,3	95	PG209	UC209G2		SC0209-45	SCC209	31,9	20,8	2,2	
	UKPG210H	135	95	57,2	21	114	60	35	M16	25	40	-	27,5	31	55	70	M6x1	76,1	100	PG210	UK210G2H	H2310	SC0210-45	SCC210	35,1	23,2	3,0	
	USPG209	120	85	53,9	20	106	54	33	M12	22	40	10,2	-	41,2	-	-	M6x1	70,3	95	PG209	US209G2		SC0209-45	SCC209	31,9	20,8	2,2	
50	ESPG210	135	95	57,2	21	114	60	35	M16	25	40	11	-	30,2	43,7	67,2	M6x1	91,5	100	PG210	ES210G2		SCOE210-50	SCCE210	35,1	23,2	2,8	50
	EXPG210	135	95	57,2	21	114	60	35	M16	25	40	24,6	-	49,2	62,7	67,2	M6x1	91,5	100	PG210	EX210G2		SCOE210-50	SCCE210	35,1	23,2	3,0	
	UCPG210	135	95	57,2	21	114	60	35	M16	25	40	19	-	51,6	-	-	M6x1	76,1	100	PG210	UC210G2		SC0210-50	SCC210	35,1	23,2	2,8	
	UKPG211H	140	100	63,5	25	126	60	34	M16	25	40	-	29	33	59	75	M6x1	77,7	110	PG211	UK211G2H	H2311	SC0211-50	SCC211	43,6	29,2	3,5	
	USPG210	135	95	57,2	21	114	60	35	M16	25	40	10,9	-	43,5	-	-	M6x1	76,1	100	PG210	US210G2		SC0210-50	SCC210	35,1	23,2	2,8	
55	ESPG211	140	100	63,5	25	126	60	34	M16	25	40	12	-	32,5	48,4	74,5	M6x1	104,5	110	PG211	ES211G2		SCOE211-55	SCCE211	43,6	29,2	3,2	55
	EXPG211	140	100	63,5	25	126	60	34	M16	25	40	27,7	-	55,4	71,3	74,5	M6x1	104,5	110	PG211	EX211G2		SCOE211-55	SCCE211	43,6	29,2	3,7	
	UCPG211	140	100	63,5	25	126	60	34	M16	25	40	22,2	-	55,6	-	-	M6x1	77,7	110	PG211	UC211G2		SC0211-55	SCC211	43,6	29,2	3,4	
	UKPG212H	150	105	69,8	25	138	70	40	M16	25	50	-	31	36	62	80	M6x1	91,3	120	PG212	UK212G2H	H2312	SC0212-55	SCC212	52,5	32,8	4,6	
	USPG211	140	100	63,5	25	126	60	34	M16	25	40	11,8	-	45,3	-	-	M6x1	77,7	110	PG211	US211G2		SC0211-55	SCC211	43,6	29,2	3,4	
60	ESPG212	150	105	69,8	25	138	70	40	M16	25	50	12	-	33,4	49,3	82	M6x1	112,5	120	PG212	ES212G2		SCOE212-60	SCCE212	52,5	32,8	4,3	60
	EXPG212	150	105	69,8	25	138	70	40	M16	25	50	30,9	-	61,8	77,7	82	M6x1	112,5	120	PG212	EX212G2		SCOE212-60	SCCE212	52,5	32,8	5,0	
	USPG212	150	105	69,8	25	138	70	40	M16	25	50	14,9	-	53,7	-	-	M6x1	91,3	120	PG212	US212G2		SC0212-60	SCC212	52,5	32,8	4,4	

* Bearing units that are ordered with cover(s) include the housings with grooves.
If you want to install the protective covers later, housings with suffix N must be ordered (for example: P210N).

CAST IRON HOUSINGS WITH CHROME STEEL BEARING INSERTS

PILLOW BLOCK UNITS

Tapped base pillow block PA2

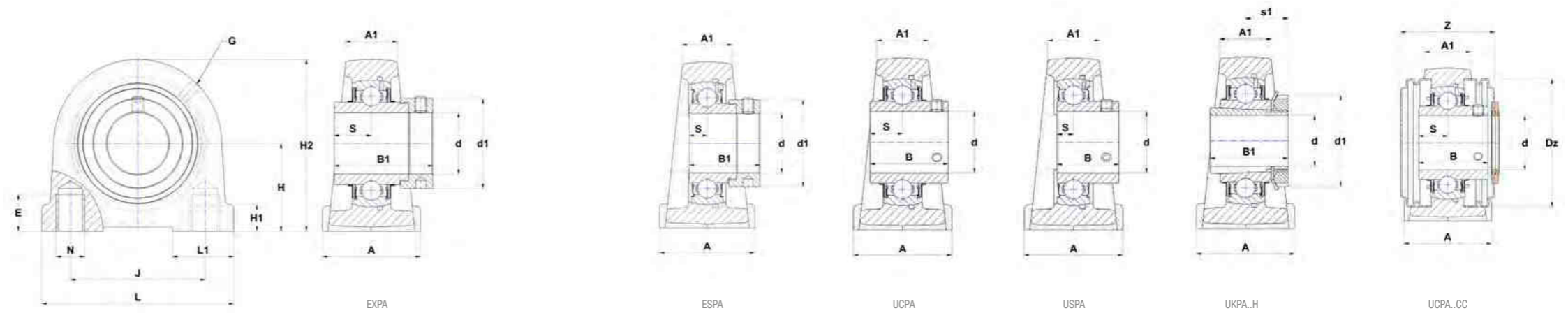

Main dimensions [mm]

d	Unit	L	J	H	H1	H2	A	A1	N	E	L1	S	s1	B	B1	d1	G	Z	Dz	Housing	Bearing insert	Adapter sleeve reference	Open protective cap*	Closed protective cap*	Dynamic load rating C [kN]	Static load rating CO [kN]	Weight [kg]	d
12	ESPA201	70	48	30,2	10	57	36	19	M8	9	20	6,5	-	19	28,6	27,2	M6x1	56	46	PA203	ES201G2	-	SCOE201-12	SCCE203	9,6	4,8	0,4	12
	EXPA201	76	52	30,2	11	62	40	22	M10	13	22	17	-	34	43,5	32,4	M6x1	64	54	PA204	EX201G2	-	SCOE204-12	SCCE204	12,8	6,7	0,7	
	UCPA201	76	52	30,2	11	62	40	22	M10	13	22	12,7	-	31	-	-	M6x1	45,6	54	PA204	UC201G2	-	SC0204-12	SCC204	12,8	6,7	0,6	
	USPA201	70	48	30,2	10	57	36	19	M8	9	20	6	-	22	-	-	M6x1	42,6	46	PA203	US201G2	-	SC0201-12	SCC203	9,6	4,8	0,4	
15	ESPA202	70	48	30,2	10	57	36	19	M8	9	20	6,5	-	19,1	28,6	27,2	M6x1	56	46	PA203	ES202G2	-	SCOE202-15	SCCE203	9,6	4,8	0,4	15
	EXPA202	76	52	30,2	11	62	40	22	M10	13	22	17	-	34	43,5	32,4	M6x1	64	54	PA204	EX202G2	-	SCOE204-15	SCCE204	12,8	6,7	0,7	
	UCPA202	76	52	30,2	11	62	40	22	M10	13	22	12,7	-	31	-	-	M6x1	45,6	54	PA204	UC202G2	-	SC0204-15	SCC204	12,8	6,7	0,6	
	USPA202	70	48	30,2	10	57	36	19	M8	9	20	6	-	22	-	-	M6x1	42,6	46	PA203	US202G2	-	SC0202-15	SCC203	9,6	4,8	0,4	
17	ESPA203	70	48	30,2	10	57	36	19	M8	9	20	6,5	-	19,1	28,6	27,2	M6x1	56	46	PA203	ES203G2	-	SCOE203-17	SCCE203	9,6	4,8	0,4	17
	EXPA203	76	52	30,2	11	62	40	22	M10	13	22	17	-	34	43,5	32,4	M6x1	64	54	PA204	EX203G2	-	SCOE204-17	SCCE204	12,8	6,7	0,7	
	UCPA203	76	52	30,2	11	62	40	22	M10	13	22	12,7	-	31	-	-	M6x1	45,6	54	PA204	UC203G2	-	SC0204-17	SCC204	12,8	6,7	0,6	
	USPA203	70	48	30,2	10	57	36	19	M8	9	20	6	-	22	-	-	M6x1	42,6	46	PA203	US203G2	-	SC0203-17	SCC203	9,6	4,8	0,4	
20	ESPA204	76	52	30,2	11	62	40	22	M10	13	22	7,5	-	21,4	30,9	32,4	M6x1	64	54	PA204	ES204G2	-	SCOE204-20	SCCE204	12,8	6,7	0,6	20
	EXPA204	76	52	30,2	11	62	40	22	M10	13	22	17	-	34	43,5	32,4	M6x1	64	54	PA204	EX204G2	-	SCOE204-20	SCCE204	12,8	6,7	0,6	
	UKPA205H	84	56	36,5	12	72	38	23	M10	15	27	-	18,5	21	35	38	M6x1	48	60	PA205	UK205G2H	H2305	SC0205-20	SCC205	14,0	7,9	0,7	
	USPA204	76	52	30,2	11	62	40	22	M10	13	22	7	-	25	-	-	M6x1	45,6	54	PA204	US204G2	-	SC0204-20	SCC204	12,8	6,7	0,5	
25	ESPA205	84	56	36,5	12	72	38	23	M10	15	27	7,5	-	21,4	30,9	37,4	M6x1	65,2	60	PA205	ES205G2	-	SCOE205-25	SCCE205	14,0	7,9	0,7	25
	EXPA205	84	56	36,5	12	72	38	23	M10	15	27	17,4	-	34,8	44,3	37,4	M6x1	65,2	60	PA205	EX205G2	-	SCOE205-25	SCCE205	14,0	7,9	0,8	
	UCPA205	84	56	36,5	12	72	38	23	M10	15	27	14,3	-	34	-	-	M6x1	48	60	PA205	UC205G2	-	SC0205-25	SCC205	14,0	7,9	0,7	
	UKPA206H	94	66	42,9	13	84	48	25	M14	18	30	-	20,5	25	38	45	M6x1	51,8	70	PA206	UK206G2H	H2306	SC0206-25	SCC206	19,5	11,2	1,2	
	USPA205	84	56	36,5	12	72	38	23	M10	15	27	7,5	-	27	-	-	M6x1	48	60	PA205	US205G2	-	SC0205-25	SCC205	14,0	7,9	0,7	
30	ESPA206	94	66	42,9	13	84	48	25	M14	18	30	9	-	23,8	35,7	44,1	M6x1	70	70	PA206	ES206G2	-	SCOE206-30	SCCE206	19,5	11,2	1,1	30
	EXPA206	94	66	42,9	13	84	48	25	M14	18	30	18,2	-	36,4	48,3	44,1	M6x1	70	70	PA206	EX206G2	-	SCOE206-30	SCCE206	19,5	11,2	1,2	
	UCPA206	94	66	42,9	13	84	48	25	M14	18	30	15,9	-	38,1	-	-	M6x1	51,8	70	PA206	UC206G2	-	SC0206-30	SCC206	19,5	11,2	1,1	
	UKPA207H	110	80	47,6	13	95	48	27	M14	20	30	-	22,5	27	43	52	M6x1	60	80	PA207	UK207G2H	H2307	SC0207-30	SCC207	25,7	15,2	1,5	
	USPA206	94	66	42,9	13	84	48	25	M14	18	30	8	-	30	-	-	M6x1	51,8	70	PA206	US206G2	-	SC0206-30	SCC206	19,5	11,2	1,1	
35	ESPA207	110	80	47,6	13	95	48	27	M14	20	30	9,5	-	25,4	38,9	51,1	M6x1	78,6	80	PA207	ES207G2	-	SCOE207-35	SCCE207	25,7	15,2	1,5	35
	EXPA207	110	80	47,6	13	95	48	27	M14	20	30	18,8	-	37,6	51,1	51,1	M6x1	78,6	80	PA207	EX207G2	-	SCOE207-35	SCCE207	25,7	15,2	1,6	
	UKPA208H	116	84	49,2	13	100	54	28	M14	20	32	-	24,5	29	46	58	M6x1	68,4	88	PA208	UK208G2H	H2308	SC0208-35	SCC208	29,6	18,2	1,8	
	USPA207	110	80	47,6	13	95	48	27	M14	20	30	8,5	-	32	-	-	M6x1	60	80	PA207	US207G2	-	SC0207-35	SCC207	25,7	15,2	1,4	

* Bearing units that are ordered with cover(s) include the housings with grooves.
If you want to install the protective covers later, housings with suffix N must be ordered (for example: P210N).

CAST IRON HOUSINGS WITH CHROME STEEL BEARING INSERTS

PILLOW BLOCK UNITS

Tapped base pillow block
PA2

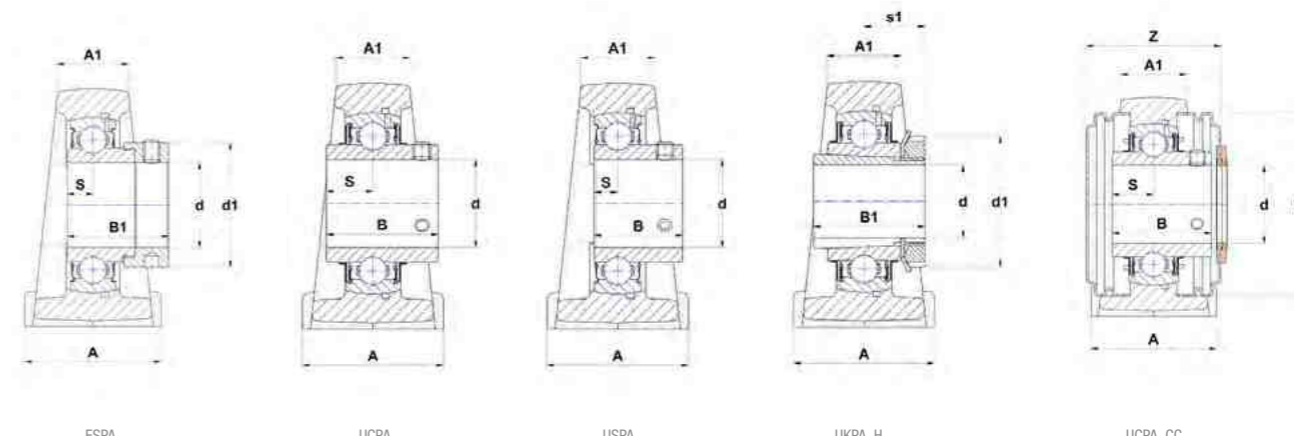
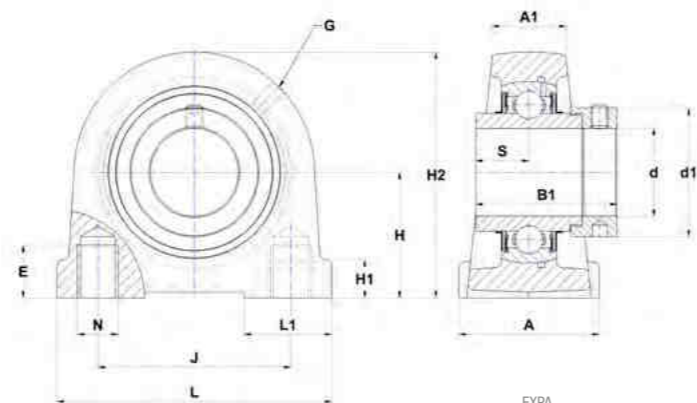

Main dimensions [mm]

d	Unit	L	J	H	H1	H2	A	A1	N	E	L1	S	s1	B	B1	d1	G	Z	Dz	Housing	Bearing insert	Adapter sleeve reference	Open protective cap*	Closed protective cap*	Dynamic load rating C [kN]	Static load rating CO [kN]	Weight [kg]	d
40	ESPA208	116	84	49,2	13	100	54	28	M14	20	32	11	-	30,2	43,7	58	M6x1	80,6	88	PA208	ES208G2	-	SCOE208-40	SCCE208	29,6	18,2	1,8	40
	EXPA208	116	84	49,2	13	100	54	28	M14	20	32	21,4	-	42,8	56,3	58	M6x1	80,6	88	PA208	EX208G2	-	SCOE208-40	SCCE208	29,6	18,2	1,9	
	UCPA208	116	84	49,2	13	100	54	28	M14	20	32	19	-	49,2	-	-	M6x1	68,4	88	PA208	UC208G2	-	SC0208-40	SCC208	29,6	18,2	1,7	
	UKPA209H	120	90	54,2	13	108	60	32	M14	25	42	-	26	30	50	65	M6x1	70,2	95	PA209	UK209G2H	H2309	SC0209-40	SCC209	31,9	20,8	2,3	
	USPA208	116	84	49,2	13	100	54	28	M14	20	32	9	-	34	-	-	M6x1	68,4	88	PA208	US208G2	-	SC0208-40	SCC208	29,6	18,2	1,7	
45	ESPA209	120	90	54,2	13	108	60	32	M14	25	42	11	-	30,2	43,7	62	M6x1	84,4	95	PA209	ES209G2	-	SCOE209-45	SCCE209	31,9	20,8	2,2	45
	EXPA209	120	90	54,2	13	108	60	32	M14	25	42	21,4	-	42,8	56,3	62	M6x1	84,4	95	PA209	EX209G2	-	SCOE209-45	SCCE209	31,9	20,8	2,4	
	UCPA209	120	90	54,2	13	108	60	32	M14	25	42	19	-	49,2	-	-	M6x1	70,2	95	PA209	UC209G2	-	SC0209-45	SCC209	31,9	20,8	2,2	
	UKPA210H	130	94	57,2	14	116	60	32	M16	25	35	-	27,5	31	55	70	M6x1	75,6	100	PA210	UK210G2H	H2310	SC0210-45	SCC210	35,1	23,2	2,8	
	USPA209	120	90	54,2	13	108	60	32	M14	25	42	10,2	-	41,2	-	-	M6x1	70,2	95	PA209	US209G2	-	SC0209-45	SCC209	31,9	20,8	2,2	
50	ESPA210	130	94	57,2	14	116	60	32	M16	25	35	11	-	30,2	43,7	67,2	M6x1	91	100	PA210	ES210G2	-	SCOE210-50	SCCE210	35,1	23,2	2,6	50
	EXPA210	130	94	57,2	14	116	60	32	M16	25	35	24,6	-	49,2	62,7	67,2	M6x1	91	100	PA210	EX210G2	-	SCOE210-50	SCCE210	35,1	23,2	2,8	
	UCPA210	130	94	57,2	14	116	60	32	M16	25	35	19	-	51,6	-	-	M6x1	75,6	100	PA210	UC210G2	-	SC0210-50	SCC210	35,1	23,2	2,6	
	UKPA211H	140	104	63,5	14	125	66	33	M16	25	47	-	29	33	59	75	M6x1	77	110	PA211	UK211G2H	H2311	SC0211-50	SCC211	43,6	29,2	3,3	
	USPA210	130	94	57,2	14	116	60	32	M16	25	35	10,9	-	43,5	-	-	M6x1	75,6	100	PA210	US210G2	-	SC0210-50	SCC210	35,1	23,2	2,6	
55	ESPA211	140	104	63,5	14	125	66	33	M16	25	47	12	-	32,5	48,4	74,5	M6x1	103,8	110	PA211	ES211G2	-	SCOE211-55	SCCE211	43,6	29,2	3,0	55
	EXPA211	140	104	63,5	14	125	66	33	M16	25	47	27,7	-	55,4	71,3	74,5	M6x1	103,8	110	PA211	EX211G2	-	SCOE211-55	SCCE211	43,6	29,2	3,5	
	UCPA211	140	104	63,5	14	125	66	33	M16	25	47	22,2	-	55,6	-	-	M6x1	77	110	PA211	UC211G2	-	SC0211-55	SCC211	43,6	29,2	3,2	
	UKPA212H	150	114	69,9	15	138	68	36	M16	25	52	-	31	36	62	80	M6x1	90	120	PA212	UK212G2H	H2312	SC0212-55	SCC212	52,5	32,8	4,2	
	USPA211	140	104	63,5	14	125	66	33	M16	25	47	11,8	-	45,3	-	-	M6x1	77	110	PA211	US211G2	-	SC0211-55	SCC211	43,6	29,2	3,2	
60	ESPA212	150	114	69,9	15	138	68	36	M16	25	52	12	-	33,4	49,3	82	M6x1	111,2	120	PA212	ES212G2	-	SCOE212-60	SCCE212	52,5	32,8	3,9	60
	EXPA212	150	114	69,9	15	138	68	36	M16	25	52	30,9	-	61,8	77,7	82	M6x1	111,2	120	PA212	EX212G2	-	SCOE212-60	SCCE212	52,5	32,8	4,6	
	UCPA212	150	114	69,9	15	138	68	36	M16	25	52	25,4	-	65,1	-	-	M6x1	90	120	PA212	UC212G2	-	SC0212-60	SCC212	52,5	32,8	4,2	
	USPA212	150	114	69,9	15	138	68	36	M16	25	52	14,9	-	53,7	-	-	M6x1	90	120	PA212	US212G2	-	SC0212-60	SCC212	52,5	32,8	4,0	

* Bearing units that are ordered with cover(s) include the housings with grooves.
If you want to install the protective covers later, housings with suffix N must be ordered (for example: P210N).

CAST IRON HOUSINGS WITH CHROME STEEL BEARING INSERTS

FLANGED UNITS

Four-bolt flange, square design
FE2

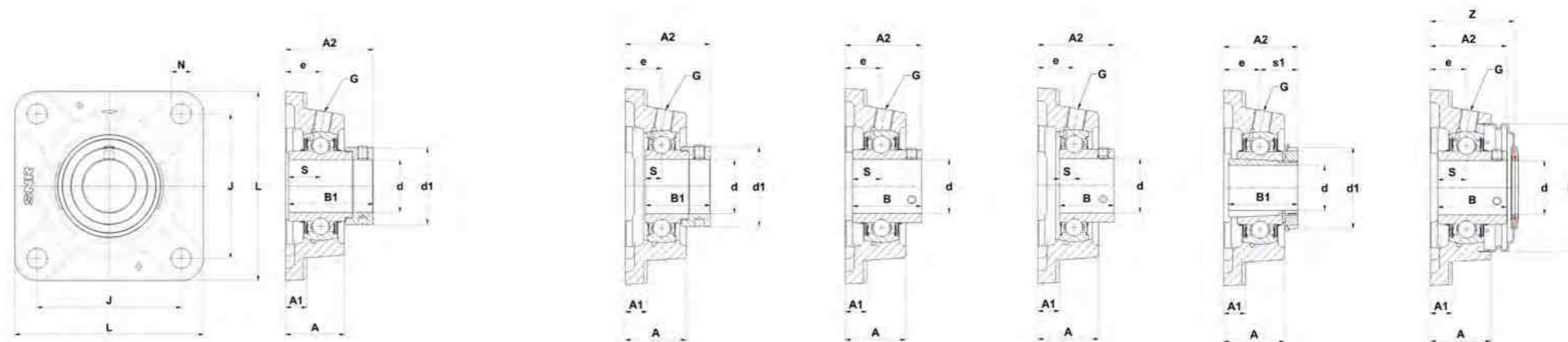

Main dimensions [mm]

d	Unit	L	J	A	A1	A2	e	N	S	s1	B	B1	d1	G	Z	Dz	Housing	Bearing insert	Adapter sleeve	Open protective cap*	Closed protective cap*	Dynamic load rating C [kN]	Static load rating C0 [kN]	Weight [kg]	d
45	ESFE209	137	105	40	13	56,7	24	14	11	-	30,2	43,7	62	R1/8"	65,5	95	FE209	ES209G2	-	SCOE209-45	SCCE209	31,9	20,8	2,2	45
	EXFE209	137	105	40	13	58,9	24	14	21,4	-	42,8	56,3	62	R1/8"	65,5	95	FE209	EX209G2	-	SCOE209-45	SCCE209	31,9	20,8	2,4	
	UCFE209	137	105	40	13	54,2	24	14	19	-	49,2	-	-	R1/8"	58,4	95	FE209	UC209G2	-	SCO209-45	SCC209	31,9	20,8	2,2	
	UKFE210H	143	111	44	13	55,5	28	18	-	27,5	31	55	70	R1/8"	63,3	100	FE210	UK210G2H	H2310	SCO210-45	SCC210	35,1	23,2	2,7	
	USFE209	137	105	40	13	55	24	14	10,2	-	41,2	-	-	R1/8"	58,4	95	FE209	US209G2	-	SCO209-45	SCC209	31,9	20,8	2,2	
50	ESFE210	143	111	44	13	60,7	28	18	11	-	30,2	43,7	67,2	R1/8"	71	100	FE210	ES210G2	-	SCOE210-50	SCCE210	35,1	23,2	2,6	50
	EXFE210	143	111	44	13	66,1	28	18	24,6	-	49,2	62,7	67,2	R1/8"	71	100	FE210	EX210G2	-	SCOE210-50	SCCE210	35,1	23,2	2,8	
	UCFE210	143	111	44	13	60,6	28	18	19	-	51,6	-	-	R1/8"	63,3	100	FE210	UC210G2	-	SCO210-50	SCC210	35,1	23,2	2,6	
	UKFE211H	162	130	48,5	15	60	31	18	-	29	33	59	75	R1/8"	68,6	110	FE211	UK211G2H	H2311	SCO211-50	SCC211	43,6	29,2	3,7	
	USFE210	143	111	44	13	60,6	28	18	10,9	-	43,5	-	-	R1/8"	63,3	100	FE210	US210G2	-	SCO210-50	SCC210	35,1	23,2	2,5	
55	ESFE211	162	130	48,5	15	67,4	31	18	12	-	32,5	48,4	74,5	R1/8"	82	110	FE211	ES211G2	-	SCOE211-55	SCCE211	43,6	29,2	3,4	55
	EXFE211	162	130	48,5	15	74,6	31	18	27,7	-	55,4	71,3	74,5	R1/8"	82	110	FE211	EX211G2	-	SCOE211-55	SCCE211	43,6	29,2	3,9	
	UCFE211	162	130	48,5	15	64,4	31	18	22,2	-	55,6	-	-	R1/8"	68,6	110	FE211	UC211G2	-	SCO211-55	SCC211	43,6	29,2	3,7	
	UKFE212H	175	143	53,5	16	65	34	18	-	31	36	62	80	R1/8"	78,9	120	FE212	UK212G2H	H2312	SCO212-55	SCC212	52,5	32,8	4,8	
	USFE211	162	130	48,5	15	64,5	31	18	11,8	-	45,3	-	-	R1/8"	68,6	110	FE211	US211G2	-	SCO211-55	SCC211	43,6	29,2	3,6	
60	ESFE212	175	143	53,5	16	71,3	34	18	12	-	33,4	49,3	82	R1/8"	89,5	120	FE212	ES212G2	-	SCOE212-60	SCCE212	52,5	32,8	4,5	60
	EXFE212	175	143	53,5	16	80,8	34	18	30,9	-	61,8	77,7	82	R1/8"	89,5	120	FE212	EX212G2	-	SCOE212-60	SCCE212	52,5	32,8	5,2	
	UCFE212	175	143	53,5	16	73,7	34	18	25,4	-	65,1	-	-	R1/8"	78,9	120	FE212	UC212G2	-	SCO212-60	SCC212	52,5	32,8	4,9	
	UKFE213H	188	150	56	18	70	38	18	-	32	36	65	85	R1/8"	80,4	132	FE213	UK213G2H	H2313	SCO213-60	SCC213	57,2	40,0	6,4	
	USFE212	175	143	53,5	16	72,8	34	18	14,9	-	53,7	-	-	R1/8"	78,9	120	FE212	US212G2	-	SCO212-60	SCC212	52,5	32,8	4,6	
65	EXFE213	188	150	56	18	89,6	38	18	34,1	-	68,2	85,7	86	R1/8"	95	132	FE213	EX213G2	-	SCOE213-65	SCCE213	57,2	40,0	6,9	65
	UCFE213	188	150	56	18	77,7	38	18	25,4	-	65,1	-	-	R1/8"	80,4	132	FE213	UC213G2	-	SCO213-65	SCCE213	57,2	40,0	6,3	
	UKFE215H	197	153	59	20	76,8	41,3	23	-	35,5	41	73	98	R1/8"	-	-	FE215	UK215G2H	H2315	-	-	66,0	49,5	6,8	
70	EXFE214	188	150	56	18	89,6	38	18	34,1	-	68,2	85,7	96,8	R1/8"	-	-	FE214	EX214G2	-	-	-	62,0	45,0	6,7	70
	UCFE214	188	150	56	18	82,4	38	18	30,2	-	74,6	-	-	R1/8"	-	-	FE214	UC214G2	-	-	-	62,0	45,0	6,1	
	UKFE216H	197	153	61	20	80,3	41,3	23	-	39	44	78	105	R1/8"	-	-	FE216	UK216G2H	H2316	-	-	72,5	54,2	7,5	
75	EXFE215	197	153	59	20	96,1	41,3	23	37,3	-	74,6	92,1	102	R1/8"	-	-	FE215	EX215G2	-	-	-	66,0	49,5	6,9	75
	UCFE215	197	153	59	20	85,8	41,3	23	33,3	-	77,8	-	-	R1/8"	-	-	FE215	UC215G2	-	-	-	66,0	49,5	6,3	
80	EXFE216	197	153	61	20	99,2	41,3	23	37,3	-	74,6	95,2	110	R1/8"	-	-	FE216	EX216G2	-	-	-	72,5	54,2	7,4	80
	UCFE216	197	153	61	20	90,6	41,3	23	33,3	-	82,6	-	-	R1/8"	-	-	FE216	UC216G2	-	-	-	72,5	54,2	7,0	
	UKFE218H	235	187	45	22	65,8	23,8	23	-	42	48	86	120	R1/8"	-	-	FE218	UK218G2H	H2318	-	-	96,0	71,5	10,6	
90	EXFE218	235	187	45	22	71,8	23,8	23	24,5	-	55	72,5	120	R1/8"	-	-	FE218	EX218G2	-	-	-	96,0	71,5	10,8	90
	UCFE218	235	187	45	22	80,1	23,8	23	39,7	-	96	-	-	R1/8"	-	-	FE218	UC218G2	-	-	-	96,0	71,5	10,4	

* Bearing units that are ordered with cover(s) include the housings with grooves.
If you want to install the protective covers later, housings with suffix N must be ordered (for example: P210N).

CAST IRON HOUSINGS WITH CHROME STEEL BEARING INSERTS

FLANGED UNITS

Four-bolt flange, square design
F2

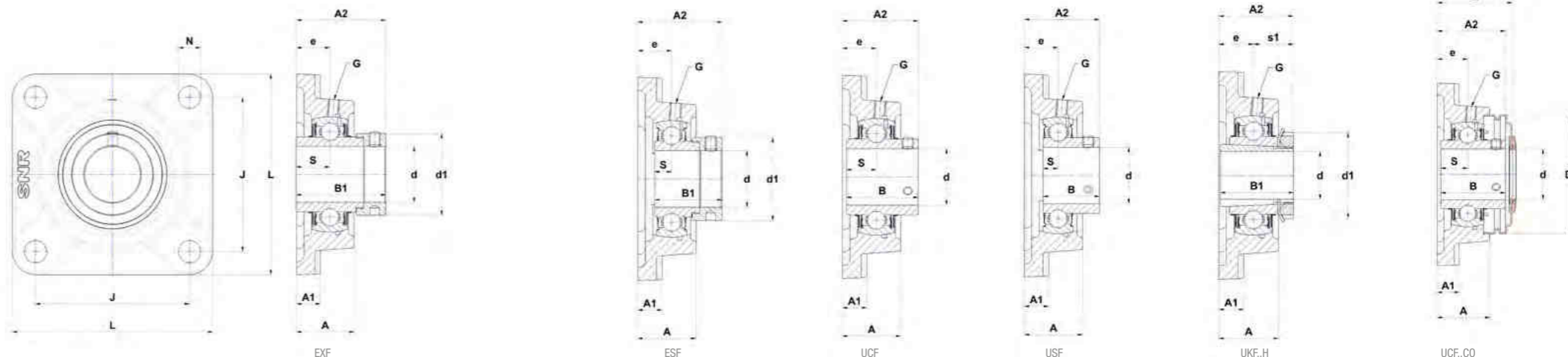

Main dimensions [mm]

d	Unit	L	J	A	A1	A2	e	N	S	s1	B	B1	d1	G	Z	Dz	Housing	Bearing insert	Adapter sleeve	Open protective cap*	Closed protective cap*	Dynamic load rating C [kN]	Static load rating C0 [kN]	Weight [kg]	d
12	ESF201	86	64	25,5	11	37,1	15	12	6,5	-	19	28,6	27,2	M6x1	43	46	F203	ES201G2	-	SCOE201-12	SCCE203	9,6	4,8	0,5	12
	EXF201	86	64	25,5	11	41,5	15	12	17	-	34	43,5	32,4	M6x1	45,8	54	F204	EX201G2	-	SCOE204-12	SCCE204	12,8	6,7	0,7	
	UCF201	86	64	25,5	11	33,3	15	12	12,7	-	31	-	-	M6x1	36,6	54	F204	UC201G2	-	SCO204-12	SCC204	12,8	6,7	0,6	
	USF201	86	64	25,5	11	31	15	12	6	-	22	-	-	M6x1	36,3	46	F203	US201G2	-	SCO201-12	SCC203	9,6	4,8	0,4	
15	ESF202	86	64	25,5	11	37,1	15	12	6,5	-	19,1	28,6	27,2	M6x1	43	46	F203	ES202G2	-	SCOE202-15	SCCE203	9,6	4,8	0,4	15
	EXF202	86	64	25,5	11	41,5	15	12	17	-	34	43,5	32,4	M6x1	45,8	54	F204	EX202G2	-	SCOE204-15	SCCE204	12,8	6,7	0,7	
	UCF202	86	64	25,5	11	33,3	15	12	12,7	-	31	-	-	M6x1	36,6	54	F204	UC202G2	-	SCO204-15	SCC204	12,8	6,7	0,6	
	USF202	86	64	25,5	11	31	15	12	6	-	22	-	-	M6x1	36,3	46	F203	US202G2	-	SCO202-15	SCC203	9,6	4,8	0,4	
17	ESF203	86	64	25,5	11	37,1	15	12	6,5	-	19,1	28,6	27,2	M6x1	43	46	F203	ES203G2	-	SCOE203-17	SCCE203	9,6	4,8	0,4	17
	EXF203	86	64	25,5	11	41,5	15	12	17	-	34	43,5	32,4	M6x1	45,8	54	F204	EX203G2	-	SCOE204-17	SCCE204	12,8	6,7	0,7	
	UCF203	86	64	25,5	11	33,3	15	12	12,7	-	31	-	-	M6x1	36,6	54	F204	UC203G2	-	SCO204-17	SCC204	12,8	6,7	0,6	
	USF203	86	64	25,5	11	31	15	12	6	-	22	-	-	M6x1	36,3	46	F203	US203G2	-	SCO203-17	SCC203	9,6	4,8	0,4	
20	ESF204	86	64	25,5	11	38,4	15	12	7,5	-	21,4	30,9	32,4	M6x1	45,8	54	F204	ES204G2	-	SCOE204-20	SCCE204	12,8	6,7	0,6	20
	EXF204	86	64	25,5	11	41,5	15	12	17	-	34	43,5	32,4	M6x1	45,8	54	F204	EX204G2	-	SCOE204-20	SCCE204	12,8	6,7	0,6	
	UCF204	86	64	25,5	11	33,3	15	12	12,7	-	31	-	-	M6x1	36,6	54	F204	UC204G2	-	SCO204-20	SCC204	12,8	6,7	0,6	
	UKF205H	95	70	27	13	34,5	16	12	-	18,5	21	35	38	M6x1	39,2	60	F205	UK205G2H	H2305	SCO205-20	SCC205	14,0	7,9	0,8	
	USF204	86	64	25,5	11	33	15	12	7	-	25	-	-	M6x1	36,6	54	F204	US204G2	-	SCO204-20	SCC204	12,8	6,7	0,6	
25	ESF205	95	70	27	13	39,4	16	12	7,5	-	21,4	30,9	37,4	M6x1	47,8	60	F205	ES205G2	-	SCOE205-25	SCCE205	14,0	7,9	0,8	25
	EXF205	95	70	27	13	42,9	16	12	17,4	-	34,8	44,3	37,4	M6x1	47,8	60	F205	EX205G2	-	SCOE205-25	SCCE205	14,0	7,9	0,8	
	UCF205	95	70	27	13	35,7	16	12	14,3	-	34	-	-	M6x1	39,2	60	F205	UC205G2	-	SCO205-25	SCC205	14,0	7,9	0,8	
	UKF206H	108	83	31	13	38,5	18	12	-	20,5	25	38	45	M6x1	44,2	70	F206	UK206G2H	H2306	SCO206-25	SCC206	19,5	11,2	1,2	
	USF205	95	70	27	13	35,5	16	12	7,5	-	27	-	-	M6x1	39,2	60	F205	US205G2	-	SCO205-25	SCC205	14,0	7,9	0,8	
30	ESF206	108	83	31	13	44,7	18	12	9	-	23,8	35,7	44,1	M6x1	53,3	70	F206	ES206G2	-	SCOE206-30	SCCE206	19,5	11,2	1,1	30
	EXF206	108	83	31	13	48,1	18	12	18,2	-	36,4	48,3	44,1	M6x1	53,3	70	F206	EX206G2	-	SCOE206-30	SCCE206	19,5	11,2	1,2	
	UCF206	108	83	31	13	40,2	18	12	15,9	-	38,1	-	-	M6x1	44,2	70	F206	UC206G2	-	SCO206-30	SCC206	19,5	11,2	1,1	
	UKF207H	117	92	34	15	41,5	19	14	-	22,5	27	43	52	M6x1	48,3	80	F207	UK207G2H	H2307	SCO207-30	SCC207	25,7	15,2	1,6	
	USF206	108	83	31	13	40	18	12	8	-	30	-	-	M6x1	44,2	70	F206	US206G2	-	SCO206-30	SCC206	19,5	11,2	1,1	
35	ESF207	117	92	34	15	48,4	19	14	9,5	-	25,4	38,9	51,1	M6x1	57,6	80	F207	ES207G2	-	SCOE207-35	SCCE207	25,7	15,2	1,5	35
	EXF207	117	92	34	15	51,3	19	14	18,8	-	37,6	51,1	51,1	M6x1	57,6	80	F207	EX207G2	-	SCOE207-35	SCCE207	25,7	15,2	1,6	
	UCF207	117	92	34	15	44,4	19	14	17,5	-	42,9	-	-	M6x1	48,3	80	F207	UC207G2	-	SCO207-35	SCC207	25,7	15,2	1,5	
	UKF208H	130	102	36	15	45,5	21	16	-	24,5	29	46	58	M6x1	54,9	88	F208	UK208G2H	H2308	SCO208-35	SCC208	29,6	18,2	2,0	
	USF207	117	92	34	15	42,5	19	14	8,5	-	32	-	-	M6x1	48,3	80	F207	US207G2	-	SCO207-35	SCC207	25,7	15,2	1,5	
40	ESF208	130	102	36	15	53,7	21	16	11	-	30,2	43,7	58	M6x1	61	88	F208	ES208G2	-	SCOE208-40	SCCE208	29,6	18,2	1,9	40
	EXF208	130	102	36	15	55,9	21	16	21,4	-	42,8	56,3	58	M6x1	61	88	F208	EX208G2	-	SCOE208-40	SCCE208	29,6	18,2	2,0	
	UCF208	130	102	36	15	51,2	21	16	19	-	49,2	-	-	M6x1	54,9	88	F208	UC208G2	-	SCO208-40	SCC208	29,6	18,2	1,9	
	UKF209H	137	105	38	16	48	22	16	-	26	30	50	65	M6x1	56,3	95	F209	UK209G2H	H2309	SCO209-40	SCC209	31,9	20,8	2,3	
	USF208	130	102	36	15	46	21	16	9	-	34	-	-	M6x1	54,9	88	F208	US208G2	-	SCO208-40	SCC208	29,6	18,2	1,9	

* Bearing units that are ordered with cover(s) include the housings with grooves.
If you want to install the protective covers later, housings with suffix N must be ordered (for example: P210N).

CAST IRON HOUSINGS WITH CHROME STEEL BEARING INSERTS

FLANGED UNITS

Four-bolt flange, square design
F2

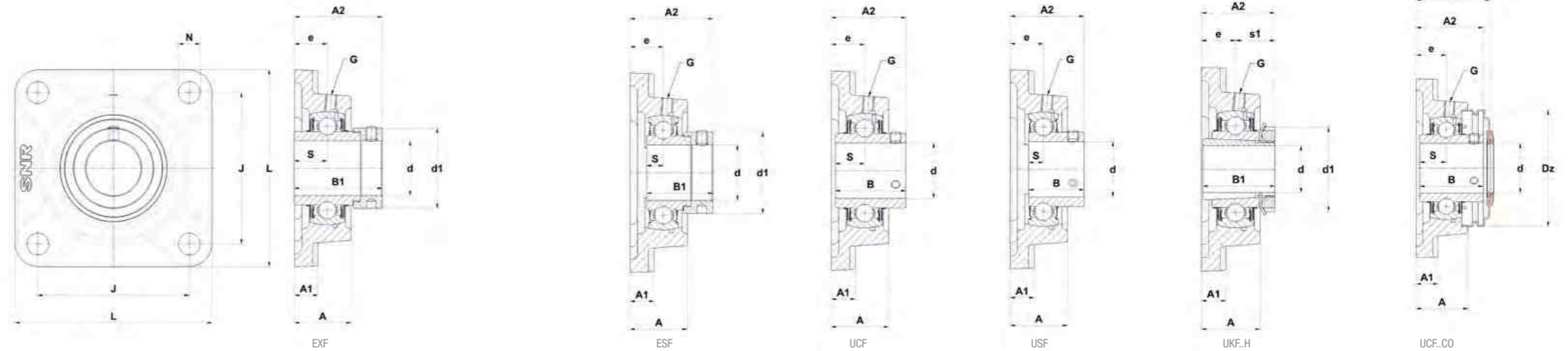

Main dimensions [mm]

d	Unit	L	J	A	A1	A2	e	N	S	s1	B	B1	d1	G	Z	Dz	Housing	Bearing insert	Adapter sleeve	Open protective cap*	Closed protective cap*	Dynamic load rating C [kN]	Static load rating C0 [kN]	Weight [kg]	d
45	ESF209	137	105	38	16	54,7	22	16	11	-	30,2	43,7	62	M6x1	63,4	95	F209	ES209G2	-	SCOE209-45	SCCE209	31,9	20,8	2,1	45
	EXF209	137	105	38	16	56,9	22	16	21,4	-	42,8	56,3	62	M6x1	63,4	95	F209	EX209G2	-	SCOE209-45	SCCE209	31,9	20,8	2,3	
	UCF209	137	105	38	16	52,2	22	16	19	-	49,2	-	-	M6x1	56,3	95	F209	UC209G2	-	SCOE209-45	SCC209	31,9	20,8	2,1	
	UKF210H	143	111	40	16	49,5	22	16	-	27,5	31	55	70	M6x1	59,3	100	F210	UK210G2H	H2310	SCOE210-45	SCC210	35,1	23,2	2,7	
	USF209	137	105	38	16	53	22	16	10,2	-	41,2	-	-	M6x1	56,3	95	F209	US209G2	-	SCOE209-45	SCC209	31,9	20,8	2,1	
50	ESF210	143	111	40	16	54,7	22	16	11	-	30,2	43,7	67,2	M6x1	67	100	F210	ES210G2	-	SCOE210-50	SCCE210	35,1	23,2	2,5	50
	EXF210	143	111	40	16	60,1	22	16	24,6	-	49,2	62,7	67,2	M6x1	67	100	F210	EX210G2	-	SCOE210-50	SCCE210	35,1	23,2	2,7	
	UCF210	143	111	40	16	54,6	22	16	19	-	51,6	-	-	M6x1	59,3	100	F210	UC210G2	-	SCOE210-50	SCC210	35,1	23,2	2,5	
	UKF211H	162	130	43	18	54	25	19	-	29	33	59	75	M6x1	62,8	110	F211	UK211G2H	H2311	SCOE211-50	SCC211	43,6	29,2	3,4	
	USF210	143	111	40	16	54,6	22	16	10,9	-	43,5	-	-	M6x1	59,3	100	F210	US210G2	-	SCOE210-50	SCC210	35,1	23,2	2,5	
55	ESF211	162	130	43	18	61,4	25	19	12	-	32,5	48,4	74,5	M6x1	76,2	110	F211	ES211G2	-	SCOE211-55	SCCE211	43,6	29,2	3,1	55
	EXF211	162	130	43	18	68,6	25	19	27,7	-	55,4	71,3	74,5	M6x1	76,2	110	F211	EX211G2	-	SCOE211-55	SCCE211	43,6	29,2	3,6	
	UCF211	162	130	43	18	58,4	25	19	22,2	-	55,6	-	-	M6x1	62,8	110	F211	UC211G2	-	SCOE211-55	SCC211	43,6	29,2	3,3	
	UKF212H	175	143	48	18	60	29	19	-	31	36	62	80	M6x1	73,2	120	F212	UK212G2H	H2312	SCOE212-55	SCC212	52,5	32,8	4,3	
	USF211	162	130	43	18	58,5	25	19	11,8	-	45,3	-	-	M6x1	62,8	110	F211	US211G2	-	SCOE211-55	SCC211	43,6	29,2	3,3	
60	ESF212	175	143	48	18	66,3	29	19	12	-	33,4	49,3	82	M6x1	83,8	120	F212	ES212G2	-	SCOE212-60	SCCE212	52,5	32,8	4,0	60
	EXF212	175	143	48	18	75,8	29	19	30,9	-	61,8	77,7	82	M6x1	83,8	120	F212	EX212G2	-	SCOE212-60	SCCE212	52,5	32,8	4,7	
	UCF212	175	143	48	18	68,7	29	19	25,4	-	65,1	-	-	M6x1	73,2	120	F212	UC212G2	-	SCOE212-60	SCC212	52,5	32,8	4,4	
	UKF213H	187	149	50	22	62	30	19	-	32	36	65	85	M6x1	74,3	132	F213	UK213G2H	H2313	SCOE213-60	SCC213	57,2	40,0	5,5	
	USF212	175	143	48	18	67,8	29	19	14,9	-	53,7	-	-	M6x1	73,2	120	F212	US212G2	-	SCOE212-60	SCC212	52,5	32,8	4,1	
65	EXF213	187	149	50	22	81,6	30	19	34,1	-	68,2	85,7	86	M6x1	88,9	132	F213	EX213G2	-	SCOE213-65	SCCE213	57,2	40,0	6,0	65
	UCF213	187	149	50	22	69,7	30	19	25,4	-	65,1	-	-	M6x1	74,3	132	F213	UC213G2	-	SCOE213-65	SCC213	57,2	40,0	5,5	
	UKF215H	200	159	56	22	69,5	34	19	-	35,5	41	73	98	M10x1	-	-	F215	UK215G2H	H2315	-	-	66,0	49,5	6,3	
70	EXF214	193	152	54	22	82,6	31	19	34,1	-	68,2	85,7	96,8	M10x1	-	-	F214	EX214G2	-	-	-	62,0	45,0	6,7	70
	UCF214	193	152	54	22	75,4	31	19	30,2	-	74,6	-	-	M10x1	-	-	F214	UC214G2	-	-	-	62,0	45,0	6,2	
	UKF216H	208	165	57	22	73	34	23	-	39	44	78	105	M10x1	-	-	F216	UK216G2H	H2316	-	-	72,5	54,2	7,3	
75	EXF215	200	159	56	22	88,8	34	19	37,3	-	74,6	92,1	102	M10x1	-	-	F215	EX215G2	-	-	-	66,0	49,5	6,4	75
	UCF215	200	159	56	22	78,5	34	19	33,3	-	77,8	-	-	M10x1	-	-	F215	UC215G2	-	-	-	66,0	49,5	5,7	
	UKF217H	220	175	63	24	76	36	23	-	40	44	82	110	M10x1	-	-	F217	UK217G2H	H2317	-	-	83,2	63,8	9,2	
80	EXF216	208	165	57	22	91,9	34	23	37,3	-	74,6	95,2	110	M10x1	-	-	F216	EX216G2	-	-	-	72,5	54,2	7,2	80
	UCF216	208	165	57	22	83,3	34	23	33,3	-	82,6	-	-	M10x1	-	-	F216	UC216G2	-	-	-	72,5	54,2	6,9	
	UKF218H	235	187	68	25	82	40	23	-	42	48	86	120	M10x1	-	-	F218	UK218G2H	H2318	-	-	96,0	71,5	11,5	
85	EXF217	220	175	63	24	85,8	36	23	23,4	-	53,2	73,2	119	M10x1	-	-	F217	EX217G2	-	-	-	83,2	63,8	9,0	85
	UCF217	220	175	63	24	87,6	36	23	34,1	-	85,7	-	-	M10x1	-	-	F217	UC217G2	-	-	-	83,2	63,8	8,7	
90	EXF218	235	187	68	25	88	40	23	24,5	-	55	72,5	120	M10x1	-	-	F218	EX218G2	-	-	-	96,0	71,5	11,7	90
	UCF218	235	187	68	25	96,3	40	23	39,7	-	96	-	-	M10x1	-	-	F218	UC218G2	-	-	-	96,0	71,5	11,3	

* Bearing units that are ordered with cover(s) include the housings with grooves.
If you want to install the protective covers later, housings with suffix N must be ordered (for example: P210N).

CAST IRON HOUSINGS WITH CHROME STEEL BEARING INSERTS

FLANGED UNITS

Pillow block regular design,
medium duty **FEX**
heavy duty **F3**

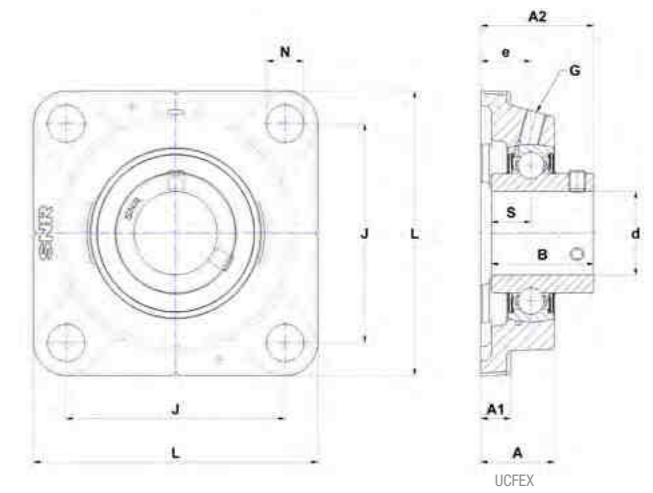
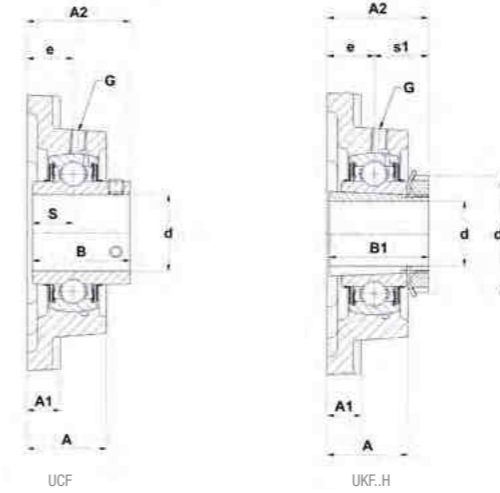
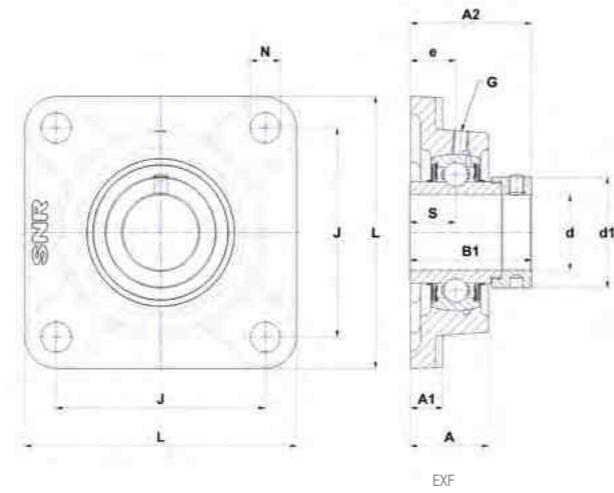

Main dimensions [mm]

d	Unit	L	J	A	A1	A2	e	N	S	s1	B	B1	d1	G	Housing	Bearing insert	Adapter sleeve	Dynamic load rating C [kN]	Static load rating C0 [kN]	Weight [kg]	d
20	UKF305H	108	80	29	13	37,5	16	16	-	21,5	27	35	38	M6x1	F305	UK305G2H	H2305	22,4	11,5	1,2	20
25	EXF305	108	80	29	13	46,1	16	16	16,7	-	34,9	46,8	42,8	M6x1	F305	EX305G2	-	22,4	11,5	1,2	25
	UCF305	108	80	29	13	39	16	16	15	-	38	-	-	M6x1	F305	UC305G2	-	22,4	11,5	1,1	
	UKF306H	125	95	32	15	41	18	16	-	23	30	38	45	M6x1	F306	UK306G2H	H2306	27,0	15,2	1,6	
30	EXF306	125	95	32	15	50,5	18	16	17,5	-	36,5	50	50	M6x1	F306	EX306G2	-	27,0	15,2	1,7	30
	UCF306	125	95	32	15	44	18	16	17	-	43	-	-	M6x1	F306	UC306G2	-	27,0	15,2	1,6	
	UKF307H	135	100	36	16	45,5	20	19	-	25,5	33	43	52	M6x1	F307	UK307G2H	H2307	33,5	19,2	2,2	
35	EXF307	135	100	36	16	53,3	20	19	18,3	-	38,1	51,6	55	M6x1	F307	EX307G2	-	33,5	19,2	2,1	35
	UCF307	135	100	36	16	49	20	19	19	-	48	-	-	M6x1	F307	UC307G2	-	33,5	19,2	2,0	
	UKF308H	150	112	40	17	50,5	23	19	-	27,5	35	46	58	M6x1	F308	UK308G2H	H2308	40,6	24,0	2,8	
40	EXF308	150	112	40	17	60,3	23	19	19,8	-	41,3	57,1	63,5	M6x1	F308	EX308G2	-	40,6	24,0	2,8	40
	UCF308	150	112	40	17	56	23	19	19	-	52	-	-	M6x1	F308	UC308G2	-	40,6	24,0	2,7	
	UCFEX08	136,5	105	35,3	14,3	54,2	24	18	19	-	49,2	-	-	R1/8"	FEX08	UCX08G2	-	31,9	20,8	2,4	
	UKF309H	160	125	44	18	55	25	19	-	30	38	50	65	M6x1	F309	UK309G2H	H2309	53,0	31,8	3,5	
45	EXF309	160	125	44	18	63,9	25	19	19,8	-	42,9	58,7	70	M6x1	F309	EX309G2	-	53,0	31,8	3,5	45
	UCF309	160	125	44	18	60	25	19	22	-	57	-	-	M6x1	F309	UC309G2	-	53,0	31,8	3,3	
	UCFEX09	142,9	111	39,7	14,3	60,5	27,9	18	19	-	51,6	-	-	R1/8"	FEX09	UCX09G2	-	35,1	23,2	2,8	
	UKF310H	175	132	48	20	60	28	23	-	32	40	55	70	M6x1	F310	UK310G2H	H2310	62,0	37,8	4,4	
50	EXF310	175	132	48	20	70	28	23	24,6	-	49,2	66,6	76,2	M6x1	F310	EX310G2	-	62,0	37,8	4,6	50
	UCF310	175	132	48	20	67	28	23	22	-	61	-	-	M6x1	F310	UC310G2	-	62,0	37,8	4,4	
	UCFEX10	162	130	43,7	17,5	64,4	31	18	22,2	-	55,6	-	-	R1/8"	FEX10	UCX10G2	-	43,6	29,2	4,0	
	UKF311H	185	140	52	20	64	30	23	-	34	43	59	75	M6x1	F311	UK311G2H	H2311	71,5	44,8	5,5	
55	EXF311	185	140	52	20	75,2	30	23	27,8	-	55,6	73	83	M6x1	F311	EX311G2	-	71,5	44,8	5,6	55
	UCF311	185	140	52	20	71	30	23	25	-	66	-	-	M6x1	F311	UC311G2	-	71,5	44,8	5,2	
	UCFEX11	174,5	143	47,6	17,5	73,7	34	18	25,4	-	65,1	-	-	R1/8"	FEX11	UCX11G2	-	52,5	32,8	4,9	
	UKF312H	193	150	56	22	69,5	33	23	-	36,5	47	62	80	M6x1	F312	UK312G2H	H2312	81,6	51,8	6,3	
60	EXF312	193	150	56	22	81,4	33	23	31	-	61,9	79,4	89	M6x1	F312	EX312G2	-	81,6	51,8	6,6	60
	UCF312	193	150	56	22	78	33	23	26	-	71	-	-	M6x1	F312	UC312G2	-	81,6	51,8	6,3	
	UCFEX12	187,6	149,22	47,8	18	77,2	32,8	18	30,2	-	74,6	-	-	R1/8"	FEX12	UCX12G2	-	62,0	45,0	6,3	
	UKF313H	208	166	58	22	71,5	33	23	-	38,5	49	65	85	M6x1	F313	UK313G2H	H2313	93,9	60,5	7,9	
65	EXF313	208	166	58	22	86,2	33	23	32,5	-	65,1	85,7	97	M6x1	F313	EX313G2	-	93,9	60,5	8,3	65
	UCF313	208	166	58	22	78	33	23	30	-	75	-	-	M6x1	F313	UC313G2	-	93,9	60,5	7,9	
	UCFEX13	196,5	152,4	52	23	81	36,5	23	33,3	-	77,8	-	-	R1/8"	FEX13-14	UCX13G2	-	66,0	49,5	7,3	
	UKF315H	236	184	66	25	81,5	39	25	-	42,5	55	73	98	M10x1	F315	UK315G2H	H2315	113,4	76,8	11,0	

CAST IRON HOUSINGS WITH CHROME STEEL BEARING INSERTS

FLANGED UNITS

Pillow block regular design,
medium duty **FEX**
heavy duty **F3**

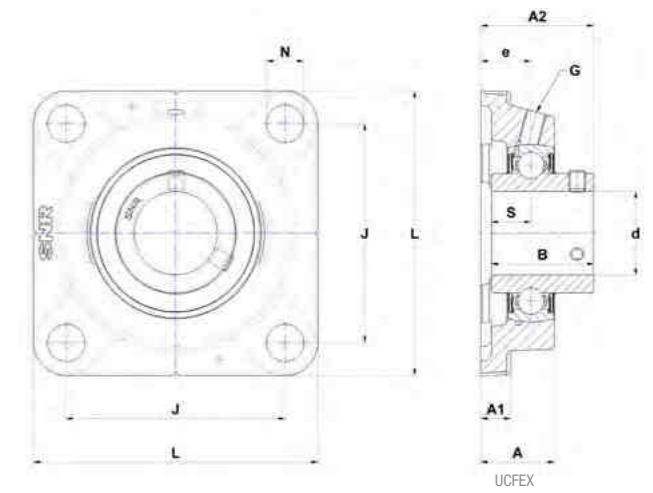
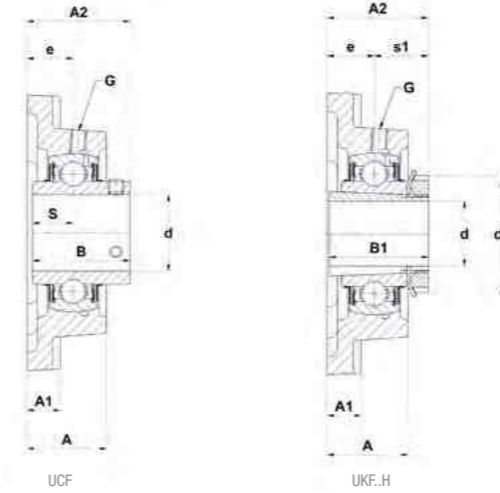
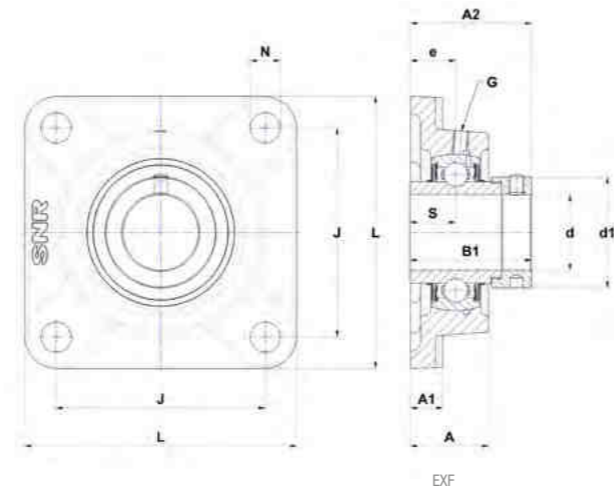

Main dimensions [mm]

d	Unit	L	J	A	A1	A2	e	N	S	s1	B	B1	d1	G	Housing	Bearing insert	Adapter sleeve	Dynamic load rating C [kN]	Static load rating C0 [kN]	Weight [kg]	d
70	EXF314	226	178	61	25	93,9	36	25	34,2	-	68,3	92,1	102	M10x1	F314	EX314G2	-	104,3	68,0	9,9	70
	UCF314	226	178	61	25	81	36	25	33	-	78	-	-	M10x1	F314	UC314G2	-	104,3	68,0	9,4	
	UCFEX14	196,5	152,4	52	23	81	36,5	23	33,3	-	77,8	-	-	R1/8"	FEX13-14	UCX14G2	-	66,0	49,5	7,0	
	UKF316H	250	196	68	27	82,5	38	31	-	44,5	55	78	105	M10x1	F316	UK316G2H	H2316	122,9	86,5	12,9	
75	EXF315	236	184	66	25	101,7	39	25	37,3	-	74,6	100	113	M10x1	F315	EX315G2	-	113,4	76,8	11,3	75
	UCF315	236	184	66	25	89	39	25	32	-	82	-	-	M10x1	F315	UC315G2	-	113,4	76,8	10,3	
	UCFEX15	196,5	152,4	56	23	88,8	39,5	23	33,3	-	82,6	-	-	R1/8"	FEX15	UCX15G2	-	72,5	54,2	8,0	
	UKF317H	260	204	74	27	92	44	31	-	48	60	82	110	M10x1	F317	UK317G2H	H2317	132,6	96,5	15,6	
80	EXF316	250	196	68	27	103,9	38	31	40,5	-	81	106,4	119	M10x1	F316	EX316G2	-	122,9	86,5	13,8	80
	UCF316	250	196	68	27	90	38	31	34	-	86	-	-	M10x1	F316	UC316G2	-	122,9	86,5	12,7	
	UCFEX16	213,5	171,5	56	26	89,6	38	23	34,1	-	85,7	-	-	R1/8"	FEX16	UCX16G2	-	83,2	63,8	10,2	
	UKF318H	280	216	76	30	92	44	35	-	48	60	86	120	M10x1	F318	UK318G2H	H2318	143,0	108,0	18,0	
85	EXF317	260	204	74	27	111,5	44	31	42	-	84,1	109,5	127	M10x1	F317	EX317G2	-	132,6	96,5	16,7	85
	UCF317	260	204	74	27	100	44	31	40	-	96	-	-	M10x1	F317	UC317G2	-	132,6	96,5	15,6	
	UKF319H	290	228	94	30	111	59	35	-	52	66	90	125	M10x1	F319	UK319G2H	H2319	156,0	122,0	21,5	
90	EXF318	280	216	76	30	116,3	44	35	43,6	-	87,3	115,9	133	M10x1	F318	EX318G2	-	143,0	108,0	19,2	90
	UCF318	280	216	76	30	100	44	35	40	-	96	-	-	M10x1	F318	UC318G2	-	143,0	108,0	17,9	
	UKF320H	310	242	94	32	113	59	38	-	54	68	97	130	M10x1	F320	UK320G2H	H2320	171,6	140,0	25,4	
95	EXF319	290	228	94	30	134,5	59	35	46,8	-	93,7	122,3	140	M10x1	F319	EX319G2	-	156,0	122,0	22,7	95
	UCF319	290	228	94	30	121	59	35	41	-	103	-	-	M10x1	F319	UC319G2	-	156,0	122,0	21,2	
100	EXF320	310	242	94	32	137,6	59	38	50	-	100	128,6	146	M10x1	F320	EX320G2	-	171,6	140,0	27,4	100
	UCF320	310	242	94	32	125	59	38	42	-	108	-	-	M10x1	F320	UC320G2	-	171,6	140,0	25,6	
	UKF322H	340	266	96	35	121	60	41	-	61	80	105	145	M10x1	F322	UK322G2H	H2322	205,0	178,0	37,7	
105	UCF321	310	242	94	32	127	59	38	44	-	112	-	-	M10x1	F321	UC321G2	-	182,0	155,0	25,9	105
110	UCF322	340	266	96	35	131	60	41	46	-	117	-	-	M10x1	F322	UC322G2	-	205,0	178,0	34,4	110
	UKF324H	370	290	110	40	130,5	65	41	-	65,5	87	112	155	M10x1	F324	UK324G2H	H2324	228,0	208,0	51,4	
115	UKF326H	410	320	115	45	133	65	41	-	68	90	121	165	M10x1	F326	UK326G2H	H2326	252,0	242,0	67,9	115
120	UCF324	370	290	110	40	140	65	41	51	-	126	-	-	M10x1	F324	UC324G2	-	228,0	208,0	48,7	120
125	UKF328H	450	350	125	55	148	75	41	-	73	98	131	180	M10x1	F328	UK328G2H	H2328	275,0	272,0	89,8	125
130	UCF326	410	320	115	45	146	65	41	54	-	135	-	-	M10x1	F326	UC326G2	-	252,0	242,0	63,0	130
140	UCF328	450	350	125	55	161	75	41	59	-	145	-	-	M10x1	F328	UC328G2	-	275,0	272,0	83,9	140

CAST IRON HOUSINGS WITH CHROME STEEL BEARING INSERTS

FLANGED UNITS

Four-bolt flange with centering rim,
round design

FCE2

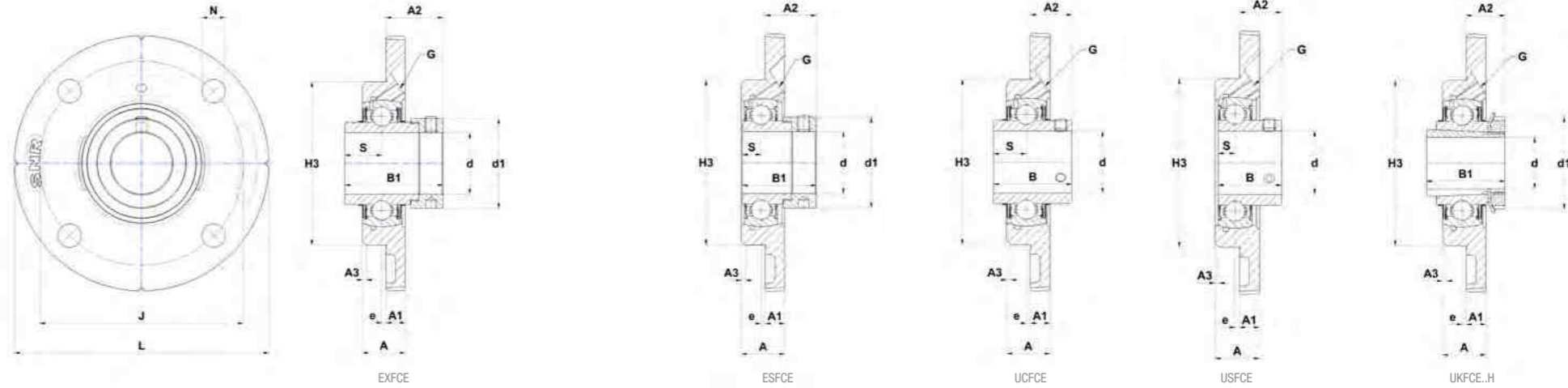

Main dimensions [mm]

d	Unit	L	J	A	A1	A2	A3	H3	e	N	S	s1	B	B1	d1	G	Housing	Bearing insert	Adapter sleeve	Dynamic load rating C [kN]	Static load rating C0 [kN]	Weight [kg]	d
12	ESFCE201	100	78	18	8	20,1	2	62	-2	9	6,5	-	19	28,6	27,2	M6x1	FCE203	ES201G2	-	9,6	4,8	0,6	12
	USFCE201	100	78	18	8	14	2	62	-2	9	6	-	22	-	-	M6x1	FCE203	US201G2	-	9,6	4,8	0,5	
	ESFCE202	100	78	18	8	20,1	2	62	-2	9	6,5	-	19,1	28,6	27,2	M6x1	FCE203	ES202G2	-	9,6	4,8	0,6	
	USFCE202	100	78	18	8	14	2	62	-2	9	6	-	22	-	-	M6x1	FCE203	US202G2	-	9,6	4,8	0,5	
15	ESFCE203	100	78	18	8	20,1	2	62	-2	9	6,5	-	19,1	28,6	27,2	M6x1	FCE203	ES203G2	-	9,6	4,8	0,6	15
	USFCE203	100	78	18	8	14	2	62	-2	9	6	-	22	-	-	M6x1	FCE203	US203G2	-	9,6	4,8	0,5	
	EXFCE201	100	78	18	8	24,5	2	62	-2	9	17	-	34	43,5	32,4	M6x1	FCE204	EX201G2	-	12,8	6,7	0,7	
	UCFCE201	100	78	18	8	16,3	2	62	-2	9	12,7	-	31	-	-	M6x1	FCE204	UC201G2	-	12,8	6,7	0,6	
17	EXFCE202	100	78	18	8	24,5	2	62	-2	9	17	-	34	43,5	32,4	M6x1	FCE204	EX202G2	-	12,8	6,7	0,6	17
	UCFCE202	100	78	18	8	16,3	2	62	-2	9	12,7	-	31	-	-	M6x1	FCE204	UC202G2	-	12,8	6,7	0,6	
	EXFCE203	100	78	18	8	24,5	2	62	-2	9	17	-	34	43,5	32,4	M6x1	FCE204	EX203G2	-	12,8	6,7	0,6	
	UCFCE203	100	78	18	8	16,3	2	62	-2	9	12,7	-	31	-	-	M6x1	FCE204	UC203G2	-	12,8	6,7	0,6	
20	ESFCE204	100	78	18	8	21,4	2	62	-2	9	7,5	-	21,4	30,9	32,4	M6x1	FCE204	ES204G2	-	12,8	6,7	0,5	20
	EXFCE204	100	78	18	8	24,5	2	62	-2	9	17	-	34	43,5	32,4	M6x1	FCE204	EX204G2	-	12,8	6,7	0,6	
	UCFCE204	100	78	18	8	16,3	2	62	-2	9	12,7	-	31	-	-	M6x1	FCE204	UC204G2	-	12,8	6,7	0,5	
	USFCE204	100	78	18	8	16	2	62	-2	9	7	-	25	-	-	M6x1	FCE204	US204G2	-	12,8	6,7	0,5	
	UKFCE205H	115	90	20	9	16	2	70	-2,5	9	-	18,5	21	35	38	M6x1	FCE205	UK205G2H	H2305	14,0	7,9	0,8	
25	ESFCE205	115	90	20	9	20,9	2	70	-2,5	9	7,5	-	21,4	30,9	37,4	M6x1	FCE205	ES205G2	-	14,0	7,9	0,8	25
	EXFCE205	115	90	20	9	24,4	2	70	-2,5	9	17,4	-	34,8	44,3	37,4	M6x1	FCE205	EX205G2	-	14,0	7,9	0,8	
	USFCE205	115	90	20	9	17	2	70	-2,5	9	7,5	-	27	-	-	M6x1	FCE205	US205G2	-	14,0	7,9	0,7	
	UKFCE206H	125	100	21	9,5	18,5	2	80	-2	11,5	-	20,5	25	38	45	M6x1	FCE206	UK206G2H	H2306	19,5	11,2	1,1	
30	ESFCE206	125	100	21	9,5	24,7	2	80	-2	11,5	9	-	23,8	35,7	44,1	M6x1	FCE206	ES206G2	-	19,5	11,2	1,0	30
	EXFCE206	125	100	21	9,5	28,1	2	80	-2	11,5	18,2	-	36,4	48,3	44,1	M6x1	FCE206	EX206G2	-	19,5	11,2	1,1	
	UCFCE206	125	100	21	9,5	20,2	2	80	-2	11,5	15,9	-	38,1	-	-	M6x1	FCE206	UC206G2	-	19,5	11,2	1,0	
	USFCE206	125	100	21	9,5	20	2	80	-2	11,5	8	-	30	-	-	M6x1	FCE206	US206G2	-	19,5	11,2	0,9	
	UKFCE207H	135	110	21	10	21,5	2	90	-1	11,5	-	22,5	27	43	52	M6x1	FCE207	UK207G2H	H2307	25,7	15,2	1,3	
35	EXFCE207	135	110	21	10	31,3	2	90	-1	11,5	18,8	-	37,6	51,1	51,1	M6x1	FCE207	EX207G2	-	25,7	15,2	1,4	35
	UCFCE207	135	110	21	10	24,4	2	90	-1	11,5	17,5	-	42,9	-	-	M6x1	FCE207	UC207G2	-	25,7	15,2	1,3	
	USFCE207	135	110	21	10	22,5	2	90	-1	11,5	8,5	-	32	-	-	M6x1	FCE207	US207G2	-	25,7	15,2	1,2	
	UKFCE208H	145	120	23	11,5	23,5	2	100	-1	11,5	-	24,5	29	46	58	M6x1	FCE208	UK208G2H	H2308	29,6	18,2	1,7	
40	ESFCE208	145	120	23	11,5	31,7	2	100	-1	11,5	11	-	30,2	43,7	58	M6x1	FCE208	ES208G2	-	29,6	18,2	1,7	40
	EXFCE208	145	120	23	11,5	33,9	2	100	-1	11,5	21,4	-	42,8	56,3	58	M6x1	FCE208	EX208G2	-	29,6	18,2	1,8	
	UCFCE208	145	120	23	11,5	29,2	2	100	-1	11,5	19	-	49,2	-	-	M6x1	FCE208	UC208G2	-	29,6	18,2	1,6	
	USFCE208	145	120	23	11,5	24	2	100	-1	11,5	9	-	34	-	-	M6x1	FCE208	US208G2	-	29,6	18,2	1,6	
	UKFCE209H	155	130	25	12	24	2	105	-2	14	-	26	30	50	65	M6x1	FCE209	UK209G2H	H2309	31,9	20,8	2,0	

CAST IRON HOUSINGS WITH CHROME STEEL BEARING INSERTS

FLANGED UNITS

Four-bolt flange with centering rim,
round design

FCE2

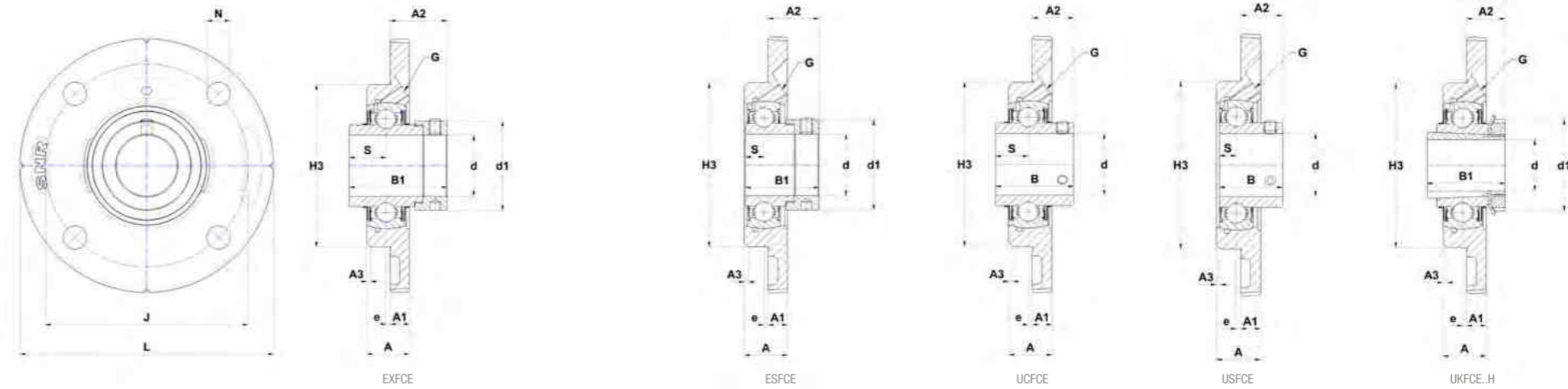

Main dimensions [mm]

d	Unit	L	J	A	A1	A2	A3	H3	e	N	S	s1	B	B1	d1	G	Housing	Bearing insert	Adapter sleeve	Dynamic load rating C [kN]	Static load rating C0 [kN]	Weight [kg]	d
45	ESFCE209	155	130	25	12	30,7	2	105	-2	14	11	-	30,2	43,7	62	M6x1	FCE209	ES209G2	-	31,9	20,8	1,9	45
	EXFCE209	155	130	25	12	32,9	2	105	-2	14	21,4	-	42,8	56,3	62	M6x1	FCE209	EX209G2	-	31,9	20,8	2,1	
	UCFCE209	155	130	25	12	28,2	2	105	-2	14	19	-	49,2	-	-	M6x1	FCE209	UC209G2	-	31,9	20,8	1,9	
	USFCE209	155	130	25	12	29	2	105	-2	14	10,2	-	41,2	-	-	M6x1	FCE209	US209G2	-	31,9	20,8	1,8	
	UKFCE210H	165	135	25,5	13	26,5	3	110	-1	14	-	-	27,5	55	70	M8x1	FCE210	UK210G2H	H2310	35,1	23,2	2,4	
50	ESFCE210	165	135	25,5	13	31,7	3	110	-1	14	11	-	30,2	43,7	67,2	M8x1	FCE210	ES210G2	-	35,1	23,2	2,2	50
	EXFCE210	165	135	25,5	13	37,1	3	110	-1	14	24,6	-	49,2	62,7	67,2	M8x1	FCE210	EX210G2	-	35,1	23,2	2,4	
	UCFCE210	165	135	25,5	13	31,6	3	110	-1	14	19	-	51,6	-	-	M8x1	FCE210	UC210G2	-	35,1	23,2	2,2	
	USFCE210	165	135	25,5	13	31,6	3	110	-1	14	10,9	-	43,5	-	-	M8x1	FCE210	US210G2	-	35,1	23,2	2,2	
	UKFCE211H	185	150	27,5	15	29	3	125	0	18	-	-	29	59	75	M6x1	FCE211	UK211G2H	H2311	43,6	29,2	3,2	
55	ESFCE211	185	150	27,5	15	36,4	3	125	0	18	12	-	32,5	48,4	74,5	M6x1	FCE211	ES211G2	-	43,6	29,2	2,9	55
	EXFCE211	185	150	27,5	15	43,6	3	125	0	18	27,7	-	55,4	71,3	74,5	M6x1	FCE211	EX211G2	-	43,6	29,2	3,4	
	UCFCE211	185	150	27,5	15	33,4	3	125	0	18	22,2	-	55,6	-	-	M6x1	FCE211	UC211G2	-	43,6	29,2	3,1	
	USFCE211	185	150	27,5	15	33,5	3	125	0	18	11,8	-	45,3	-	-	M6x1	FCE211	US211G2	-	43,6	29,2	3,1	
	UKFCE212H	195	160	30,5	16	30	3	135	-1	18	-	-	31	62	80	R1/8"	FCE212	UK212G2H	H2312	52,5	32,8	3,8	
60	ESFCE212	195	160	30,5	16	36,3	3	135	-1	18	12	-	33,4	49,3	82	R1/8"	FCE212	ES212G2	-	52,5	32,8	3,5	60
	EXFCE212	195	160	30,5	16	45,8	3	135	-1	18	30,9	-	61,8	77,7	82	R1/8"	FCE212	EX212G2	-	52,5	32,8	4,2	
	UCFCE212	195	160	30,5	16	38,7	3	135	-1	18	25,4	-	65,1	-	-	R1/8"	FCE212	UC212G2	-	52,5	32,8	3,9	
	USFCE212	195	160	30,5	16	37,8	3	135	-1	18	14,9	-	53,7	-	-	R1/8"	FCE212	US212G2	-	52,5	32,8	3,6	
	UKFCE213H	215	177	33	18	32	6	150	0	18	-	-	32	65	85	R1/8"	FCE213	UK213G2H	H2313	57,2	40,0	5,2	
65	EXFCE213	215	177	33	18	51,6	6	150	0	18	34,1	-	68,2	85,7	86	R1/8"	FCE213	EX213G2	-	57,2	40,0	5,7	65
	UCFCE213	215	177	33	18	39,7	6	150	0	18	25,4	-	65,1	-	-	R1/8"	FCE213	UC213G2	-	57,2	40,0	5,1	
	EXFCE214	215	177	33	18	51,6	6	150	0	18	34,1	-	68,2	85,7	96,8	R1/8"	FCE214	EX214G2	-	62,0	45,0	5,6	
70	UKFCE215H	220	184	33	18	35,5	6	160	0	18	-	35,5	41	73	98	R1/8"	FCE215	UK215G2H	H2315	66,0	49,5	6,0	70
	EXFCE215	220	184	33	18	54,8	6	160	0	18	37,3	-	74,6	92,1	102	R1/8"	FCE215	EX215G2	-	66,0	49,5	6,1	
75	UCFCE215	220	184	33	18	44,5	6	160	0	18	33,3	-	77,8	-	-	R1/8"	FCE215	UC215G2	-	66,0	49,5	5,5	75
	UKFCE216H	220	184	33	18,5	41	6	160	2	18	-	39	44	78	105	R1/8"	FCE216	UK216G2H	H2316	72,5	54,2	6,0	
80	EXFCE216	220	184	33	18,5	59,9	6	160	2	18	37,3	-	74,6	95,2	110	R1/8"	FCE216	EX216G2	-	72,5	54,2	5,9	80
	UCFCE216	220	184	33	18,5	51,3	6	160	2	18	33,3	-	82,6	-	-	R1/8"	FCE216	UC216G2	-	72,5	54,2	5,6	
	UKFCE218H	265	220	37	22,5	46	3	190	4	23	-	42	48	86	120	R1/8"	FCE218	UK218G2H	H2318	96,0	71,5	10,1	
90	EXFCE218	265	220	37	22,5	52	3	190	4	23	24,5	-	55	72,5	120	R1/8"	FCE218	EX218G2	-	96,0	71,5	10,3	90
	UCFCE218	265	220	37	22,5	60,3	3	190	4	23	39,7	-	96	-	-	R1/8"	FCE218	UC218G2	-	96,0	71,5	9,9	

CAST IRON HOUSINGS WITH CHROME STEEL BEARING INSERTS

FLANGED UNITS

Four-bolt flange with centering rim, round design
FEE2

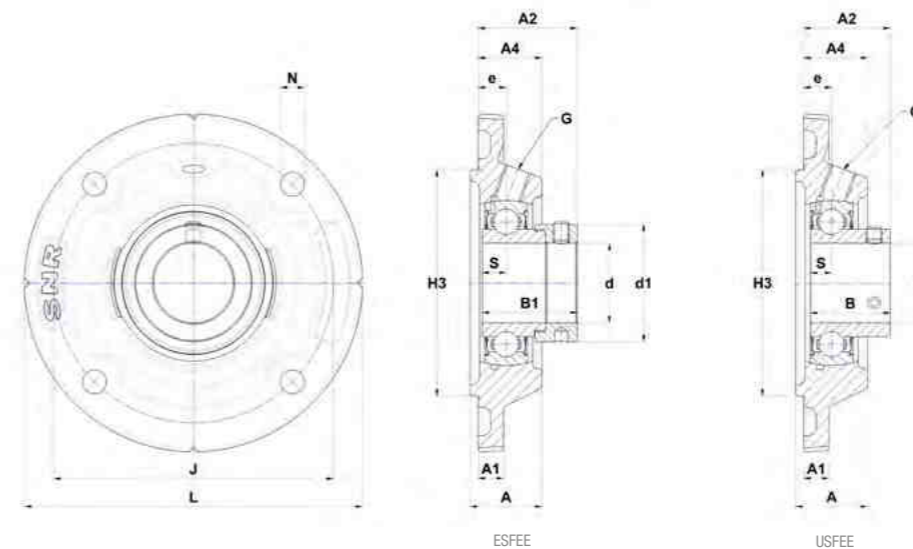

Main dimensions [mm]

d	Unit	L	J	A	A1	A2	A4	H3	e	N	S	B	B1	d1	G	Housing	Bearing insert	Dynamic load rating C [kN]	Static load rating C0 [kN]	Weight [kg]	d
25	ESFEE205	115	92	23,5	9	32,9	20,5	75	9,5	9	7,5	21,4	30,9	37,4	R1/8"	FEE205	ES205G2	14,0	7,9	0,8	25
	USFEE205	115	92	23,5	9	29	20,5	75	9,5	9	7,5	27	-	-	R1/8"	FEE205	US205G2	14,0	7,9	0,8	25
30	ESFEE206	127	105	27	9,5	37,2	24	85	10,5	9	9	23,8	35,7	44,1	R1/8"	FEE206	ES206G2	19,5	11,2	1,2	30
	USFEE206	127	105	27	9,5	32,5	24	85	10,5	9	8	30	-	-	R1/8"	FEE206	US206G2	19,5	11,2	1,2	30
35	ESFEE207	135	110	28	10	38,4	24	90	9	11,5	9,5	25,4	38,9	51,1	R1/8"	FEE207	ES207G2	25,7	15,2	1,5	35
	USFEE207	135	110	28	10	32,5	24	90	9	11,5	8,5	32	-	-	R1/8"	FEE207	US207G2	25,7	15,2	1,4	35
45	ESFEE209	155	130	31,5	12	44,2	27,5	105	11,5	14	11	30,2	43,7	62	R1/8"	FEE209	ES209G2	31,9	20,8	2,1	45
50	ESFEE210	165	136	32,5	13	45,2	28,5	115	12,5	14	11	30,2	43,7	67,2	R1/8"	FEE210	ES210G2	35,1	23,2	2,5	50
	USFEE210	165	136	32,5	13	45,1	28,5	115	12,5	14	10,9	43,5	-	-	R1/8"	FEE210	US210G2	35,1	23,2	2,5	50
60	ESFEE212	195	165	40,5	16	54,3	36,5	140	17	14	12	33,4	49,3	82	R1/8"	FEE212	ES212G2	52,5	32,8	4,2	60
	USFEE212	195	165	40,5	16	55,8	36,5	140	17	14	14,9	53,7	-	-	R1/8"	FEE212	US212G2	52,5	32,8	4,3	60

CAST IRON HOUSINGS WITH CHROME STEEL BEARING INSERTS

FLANGED UNITS

Three-bolt flange, triangular design

FTE2

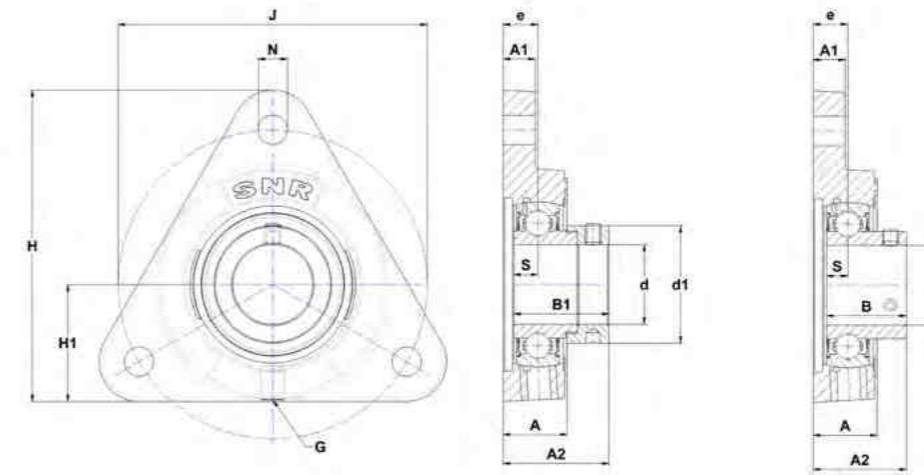

Main dimensions [mm]

d	Unit	H	H1	J	A	A1	A2	e	N	S	B	B1	d1	G	Housing	Bearing insert	Dynamic load rating C [kN]	Static load rating C0 [kN]	Weight [kg]	d
12	ESFTE201	81	31	76,1	20	11	32,1	10	11,5	6,5	19	28,6	27,2	M6x1	FTE202	ES201G2	9,6	4,8	0,4	12
	USFTE201	81	31	76,1	20	11	26	10	11,5	6	22	-	-	M6x1	FTE202	US201G2	9,6	4,8	0,4	
15	ESFTE202	81	31	76,1	20	11	32,1	10	11,5	6,5	19,1	28,6	27,2	M6x1	FTE202	ES202G2	9,6	4,8	0,4	15
	USFTE202	81	31	76,1	20	11	26	10	11,5	6	22	-	-	M6x1	FTE202	US202G2	9,6	4,8	0,4	
17	ESFTE203	81	31	76,1	20	11	32,1	10	11,5	6,5	19,1	28,6	27,2	M6x1	FTE202	ES203G2	9,6	4,8	0,4	17
	USFTE203	81	31	76,1	20	11	26	10	11,5	6	22	-	-	M6x1	FTE202	US203G2	9,6	4,8	0,4	
20	ESFTE204	92	35	89,5	20	11	34,4	11	11,5	7,5	21,4	30,9	32,4	R1/8"	FTE204	ES204G2	12,8	6,7	0,6	20
	USFTE204	92	35	89,5	20	11	29	11	11,5	7	25	-	-	R1/8"	FTE204	US204G2	12,8	6,7	0,5	
25	ESFTE205	97	36	96	22	12	36	12,6	11	7,5	21,4	30,9	37,4	R1/8"	FTE205	ES205G2	14,0	7,9	0,6	25
	USFTE205	97	36	96	22	12	32,1	12,6	11	7,5	27	-	-	R1/8"	FTE205	US205G2	14,0	7,9	0,6	
30	ESFTE206	117	44	116	24	12	39,7	13	11	9	23,8	35,7	44,1	R1/8"	FTE206	ES206G2	19,5	11,2	1,1	30
	USFTE206	117	44	116	24	12	35	13	11	8	30	-	-	R1/8"	FTE206	US206G2	19,5	11,2	1,1	
35	ESFTE207	128	48	129,7	27	16	45	15,6	13,5	9,5	25,4	38,9	51,1	R1/8"	FTE207	ES207G2	25,7	15,2	1,5	35
	USFTE207	128	48	129,7	27	16	39,1	15,6	13,5	8,5	32	-	-	R1/8"	FTE207	US207G2	25,7	15,2	1,4	
40	ESFTE208	153	51	140	30	16	51,5	18,8	13,5	11	30,2	43,7	58	R1/8"	FTE208	ES208G2	29,6	18,2	2,3	40
	USFTE208	153	51	140	30	16	43,8	18,8	13,5	9	34	-	-	R1/8"	FTE208	US208G2	29,6	18,2	2,3	
45	ESFTE209	150	55	160	33	16	51,9	19,2	14	11	30,2	43,7	62	R1/8"	FTE209	ES209G2	31,9	20,8	2,1	45
	USFTE209	150	55	160	33	16	50,2	19,2	14	10,2	41,2	-	-	R1/8"	FTE209	US209G2	31,9	20,8	2,1	
50	ESFTE210	150	55	160	33	16	51,9	19,2	14	11	30,2	43,7	67,2	R1/8"	FTE210	ES210G2	35,1	23,2	2,1	50
	USFTE210	150	55	160	33	16	51,8	19,2	14	10,9	43,5	-	-	R1/8"	FTE210	US210G2	35,1	23,2	2,1	

CAST IRON HOUSINGS WITH CHROME STEEL BEARING INSERTS

FLANGED UNITS

Two-bolt flange, oval design

FLE2

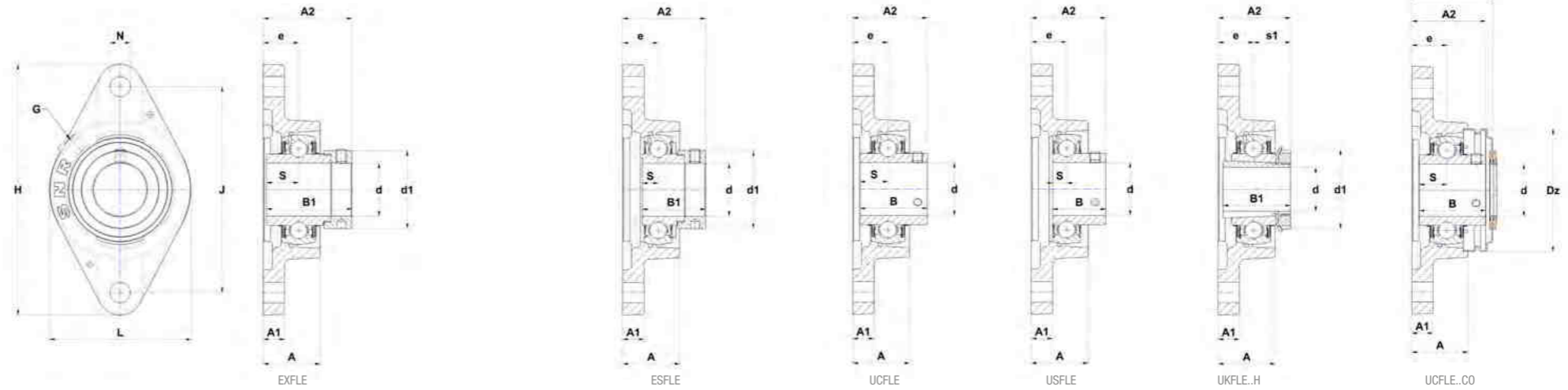

Main dimensions [mm]

α	Unit	L	H	J	A	A1	A2	e	N	S	s1	B	B1	d1	G	Z	Dz	Housing	Bearing insert	Adapter sleeve	Open protective cap*	Closed protective cap*	Dynamic load rating C [kN]	Static load rating C0 [kN]	Weight [kg]	d
12	ESFLE201	57	99	76,5	26	9,5	39,1	17	11,5	6,5	-	19	28,6	27,2	M6x1	44,3	46	FLE203	ES201G2	-	SCOE201-12	SCCE203	9,6	4,8	0,4	12
	EXFLE201	61	112	90	30,3	10	45,5	19	11,5	17	-	34	43,5	32,4	R1/8"	50,8	54	FLE204	EX201G2	-	SCOE204-12	SCCE204	12,8	6,7	0,6	
	UCFLE201	61	112	90	30,3	10	37,3	19	11,5	12,7	-	31	-	-	R1/8"	41,6	54	FLE204	UC201G2	-	SC0204-12	SCC204	12,8	6,7	0,5	
	USFLE201	57	99	76,5	26	9,5	33	17	11,5	6	-	22	-	-	M6x1	37,6	46	FLE203	US201G2	-	SC0201-12	SCC203	9,6	4,8	0,4	
15	ESFLE202	57	99	76,5	26	9,5	39,1	17	11,5	6,5	-	19,1	28,6	27,2	M6x1	44,3	46	FLE203	ES202G2	-	SCOE202-15	SCCE203	9,6	4,8	0,4	15
	EXFLE202	61	112	90	30,3	10	45,5	19	11,5	17	-	34	43,5	32,4	R1/8"	50,8	54	FLE204	EX202G2	-	SCOE204-15	SCCE204	12,8	6,7	0,6	
	UCFLE202	61	112	90	30,3	10	37,3	19	11,5	12,7	-	31	-	-	R1/8"	41,6	54	FLE204	UC202G2	-	SC0204-15	SCC204	12,8	6,7	0,5	
	USFLE202	57	99	76,5	26	9,5	33	17	11,5	6	-	22	-	-	M6x1	37,6	46	FLE203	US202G2	-	SC0202-15	SCC203	9,6	4,8	0,3	
17	ESFLE203	57	99	76,5	26	9,5	39,1	17	11,5	6,5	-	19,1	28,6	27,2	M6x1	44,3	46	FLE203	ES203G2	-	SCOE203-17	SCCE203	9,6	4,8	0,4	17
	EXFLE203	61	112	90	30,3	10	45,5	19	11,5	17	-	34	43,5	32,4	R1/8"	50,8	54	FLE204	EX203G2	-	SCOE204-17	SCCE204	12,8	6,7	0,6	
	UCFLE203	61	112	90	30,3	10	37,3	19	11,5	12,7	-	31	-	-	R1/8"	41,6	54	FLE204	UC203G2	-	SC0204-17	SCC204	12,8	6,7	0,5	
	USFLE203	57	99	76,5	26	9,5	33	17	11,5	6	-	22	-	-	M6x1	37,6	46	FLE203	US203G2	-	SC0203-17	SCC203	9,6	4,8	0,4	
20	ESFLE204	61	112	90	30,3	10	42,4	19	11,5	7,5	-	21,4	30,9	32,4	R1/8"	50,8	54	FLE204	ES204G2	-	SCOE204-20	SCCE204	12,8	6,7	0,5	20
	EXFLE204	61	112	90	30,3	10	45,5	19	11,5	17	-	34	43,5	32,4	R1/8"	50,8	54	FLE204	EX204G2	-	SCOE204-20	SCCE204	12,8	6,7	0,5	
	UCFLE204	61	112	90	30,3	10	37,3	19	11,5	12,7	-	31	-	-	R1/8"	41,6	54	FLE204	UC204G2	-	SC0204-20	SCC204	12,8	6,7	0,5	
	UKFLE205H	70	124	99	29,3	11	37,5	19	11,5	-	18,5	21	35	38	R1/8"	42	60	FLE205	UK205G2H	H2305	SC0205-20	SCC205	14,0	7,9	0,6	
	USFLE204	61	112	90	30,3	10	37	19	11,5	7	-	25	-	-	R1/8"	41,6	54	FLE204	US204G2	-	SC0204-20	SCC204	12,8	6,7	0,4	
25	ESFLE205	70	124	99	29,3	11	42,4	19	11,5	7,5	-	21,4	30,9	37,4	R1/8"	50,6	60	FLE205	ES205G2	-	SCOE205-25	SCCE205	14,0	7,9	0,6	25
	EXFLE205	70	124	99	29,3	11	45,9	19	11,5	17,4	-	34,8	44,3	37,4	R1/8"	50,6	60	FLE205	EX205G2	-	SCOE205-25	SCCE205	14,0	7,9	0,7	
	UCFLE205	70	124	99	29,3	11	38,7	19	11,5	14,3	-	34	-	-	R1/8"	42	60	FLE205	UC205G2	-	SC0205-25	SCC205	14,0	7,9	0,6	
	UKFLE206H	80	142	116,5	32,1	12	40,5	20	11,5	-	20,5	25	38	45	R1/8"	46,3	70	FLE206	UK206G2H	H2306	SC0206-25	SCC206	19,5	11,2	0,9	
	USFLE205	70	124	99	29,3	11	38,5	19	11,5	7,5	-	27	-	-	R1/8"	42	60	FLE205	US205G2	-	SC0205-25	SCC205	14,0	7,9	0,6	
30	ESFLE206	80	142	116,5	32,1	12	46,7	20	11,5	9	-	23,8	35,7	44,1	R1/8"	55,4	70	FLE206	ES206G2	-	SCOE206-30	SCCE206	19,5	11,2	0,8	30
	EXFLE206	80	142	116,5	32,1	12	50,1	20	11,5	18,2	-	36,4	48,3	44,1	R1/8"	55,4	70	FLE206	EX206G2	-	SCOE206-30	SCCE206	19,5	11,2	0,9	
	UCFLE206	80	142	116,5	32,1	12	42,2	20	11,5	15,9	-	38,1	-	-	R1/8"	46,3	70	FLE206	UC206G2	-	SC0206-30	SCC206	19,5	11,2	0,8	
	UKFLE207H	92	155	130	33,7	12,5	43,5	21	14	-	22,5	27	43	52	R1/8"	49,6	80	FLE207	UK207G2H	H2307	SC0207-30	SCC207	25,7	15,2	1,2	
	USFLE206	80	142	116,5	32,1	12	42	20	11,5	8	-	30	-	-	R1/8"	46,3	70	FLE206	US206G2	-	SC0206-30	SCC206	19,5	11,2	0,8	
35	ESFLE207	92	155	130	33,7	12,5	50,4	21	14	9,5	-	25,4	38,9	51,1	R1/8"	58,9	80	FLE207	ES207G2	-	SCOE207-35	SCCE207	25,7	15,2	1,2	35
	EXFLE207	92	155	130	33,7	12,5	53,3	21	14	18,8	-	37,6	51,1	51,1	R1/8"	58,9	80	FLE207	EX207G2	-	SCOE207-35	SCCE207	25,7	15,2	1,3	
	UCFLE207	92	155	130	33,7	12,5	46,4	21	14	17,5	-	42,9	-	-	R1/8"	49,6	80	FLE207	UC207G2	-	SC0207-35	SCC207	25,7	15,2	1,2	
	UKFLE208H	105	172	143,5	37,5	13	48,5	24	14	-	24,5	29	46	58	R1/8"	57,7	88	FLE208	UK208G2H	H2308	SC0208-35	SCC208	29,6	18,2	1,7	
	USFLE207	92	155	130	33,7	12,5	44,5	21	14	8,5	-	32	-	-	R1/8"	49,6	80	FLE207	US207G2	-	SC0207-35	SCC207	25,7	15,2	1,1	

* Bearing units that are ordered with cover(s) include the housings with grooves.
If you want to install the protective covers later, housings with suffix N must be ordered (for example: P210N).

CAST IRON HOUSINGS WITH CHROME STEEL BEARING INSERTS

FLANGED UNITS

Two-bolt flange, oval design

FLE2

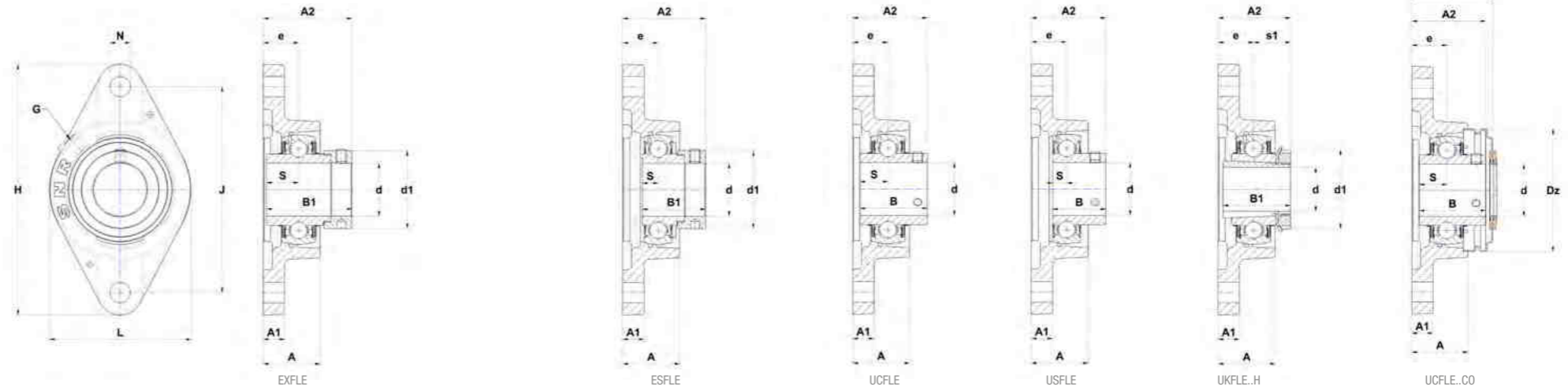

Main dimensions [mm]

d	Unit	L	H	J	A	A1	A2	e	N	S	s1	B	B1	d1	G	Z	Dz	Housing	Bearing insert	Adapter sleeve	Open protective cap*	Closed protective cap*	Dynamic load rating C [kN]	Static load rating CO [kN]	Weight [kg]	d
40	ESFLE208	105	172	143,5	37,5	13	56,7	24	14	11	-	30,2	43,7	58	R1/8"	63,8	88	FLE208	ES208G2	-	SCOE208-40	SCCE208	29,6	18,2	1,7	40
	EXFLE208	105	172	143,5	37,5	13	58,9	24	14	21,4	-	42,8	56,3	58	R1/8"	63,8	88	FLE208	EX208G2	-	SCOE208-40	SCCE208	29,6	18,2	1,8	
	UCFLE208	105	172	143,5	37,5	13	54,2	24	14	19	-	49,2	-	-	R1/8"	57,7	88	FLE208	UC208G2	-	SCOE208-40	SCC208	29,6	18,2	1,6	
	UKFLE209H	111	180	148,5	37,5	13	50	24	14	-	26	30	50	65	R1/8"	57,7	95	FLE209	UK209G2H	H2309	SCOE209-40	SCC209	31,9	20,8	1,9	
	USFLE208	105	172	143,5	37,5	13	49	24	14	9	-	34	-	-	R1/8"	57,7	88	FLE208	US208G2	-	SCOE208-40	SCC208	29,6	18,2	1,6	
45	ESFLE209	111	180	148,5	37,5	13	56,7	24	14	11	-	30,2	43,7	62	R1/8"	64,8	95	FLE209	ES209G2	-	SCOE209-45	SCCE209	31,9	20,8	1,8	45
	EXFLE209	111	180	148,5	37,5	13	58,9	24	14	21,4	-	42,8	56,3	62	R1/8"	64,8	95	FLE209	EX209G2	-	SCOE209-45	SCCE209	31,9	20,8	2,0	
	UCFLE209	111	180	148,5	37,5	13	54,2	24	14	19	-	49,2	-	-	R1/8"	57,7	95	FLE209	UC209G2	-	SCOE209-45	SCC209	31,9	20,8	1,8	
	UKFLE210H	116	190	157	41,6	13	55,5	28	18	-	27,5	31	55	70	R1/8"	64,7	100	FLE210	UK210G2H	H2310	SCOE210-45	SCC210	35,1	23,2	2,3	
	USFLE209	111	180	148,5	37,5	13	55	24	14	10,2	-	41,2	-	-	R1/8"	57,7	95	FLE209	US209G2	-	SCOE209-45	SCC209	31,9	20,8	1,8	
50	ESFLE210	116	190	157	41,6	13	60,7	28	18	11	-	30,2	43,7	67,2	R1/8"	72,4	100	FLE210	ES210G2	-	SCOE210-50	SCCE210	35,1	23,2	2,1	50
	EXFLE210	116	190	157	41,6	13	66,1	28	18	24,6	-	49,2	62,7	67,2	R1/8"	72,4	100	FLE210	EX210G2	-	SCOE210-50	SCCE210	35,1	23,2	2,3	
	UCFLE210	116	190	157	41,6	13	60,6	28	18	19	-	51,6	-	-	R1/8"	64,7	100	FLE210	UC210G2	-	SCOE210-50	SCC210	35,1	23,2	2,1	
	UKFLE211H	134	222	184	45,8	15	60	31	18	-	29	33	59	75	R1/8"	68,2	110	FLE211	UK211G2H	H2311	SCOE211-50	SCC211	43,6	29,2	3,3	
	USFLE210	116	190	157	41,6	13	60,6	28	18	10,9	-	43,5	-	-	R1/8"	64,7	100	FLE210	US210G2	-	SCOE210-50	SCC210	35,1	23,2	2,1	
55	ESFLE211	134	222	184	45,8	15	67,4	31	18	12	-	32,5	48,4	74,5	R1/8"	81,6	110	FLE211	ES211G2	-	SCOE211-55	SCCE211	43,6	29,2	3,0	55
	EXFLE211	134	222	184	45,8	15	74,6	31	18	27,7	-	55,4	71,3	74,5	R1/8"	81,6	110	FLE211	EX211G2	-	SCOE211-55	SCCE211	43,6	29,2	3,5	
	UCFLE211	134	222	184	45,8	15	64,4	31	18	22,2	-	55,6	-	-	R1/8"	68,2	110	FLE211	UC211G2	-	SCOE211-55	SCC211	43,6	29,2	3,2	
	UKFLE212H	138	238	202	50,4	16	65	34	18	-	31	36	62	80	R1/8"	77,6	120	FLE212	UK212G2H	H2312	SCOE212-55	SCC212	52,5	32,8	3,7	
	USFLE211	134	222	184	45,8	15	64,5	31	18	11,8	-	45,3	-	-	R1/8"	68,2	110	FLE211	US211G2	-	SCOE211-55	SCC211	43,6	29,2	3,2	
60	ESFLE212	138	238	202	50,4	16	71,3	34	18	12	-	33,4	49,3	82	R1/8"	88,2	120	FLE212	ES212G2	-	SCOE212-60	SCCE212	52,5	32,8	3,4	60
	EXFLE212	138	238	202	50,4	16	80,8	34	18	30,9	-	61,8	77,7	82	R1/8"	88,2	120	FLE212	EX212G2	-	SCOE212-60	SCCE212	52,5	32,8	4,1	
	UCFLE212	138	238	202	50,4	16	73,7	34	18	25,4	-	65,1	-	-	R1/8"	77,6	120	FLE212	UC212G2	-	SCOE212-60	SCC212	52,5	32,8	3,7	
	UKFLE213H	160	258	216	57	18	70	38	21	-	32	36	65	85	R1/8"	82,4	132	FLE213	UK213G2H	H2313	SCOE213-60	SCC213	57,2	40,0	5,6	
	USFLE212	138	238	202	50,4	16	72,8	34	18	14,9	-	53,7	-	-	R1/8"	77,6	120	FLE212	US212G2	-	SCOE212-60	SCC212	52,5	32,8	3,5	
65	EXFLE213	160	258	216	57	18	89,6	38	21	34,1	-	68,2	85,7	86	R1/8"	97	132	FLE213	EX213G2	-	SCOE213-65	SCCE213	57,2	40,0	6,1	65
	UCFLE213	160	258	216	57	18	77,7	38	21	25,4	-	65,1	-	-	R1/8"	82,4	132	FLE213	UC213G2	-	SCOE213-65	SCC213	57,2	40,0	5,6	
	UKFLE215H	160	258	216	57	18	73,5	38	21	-	35,5	41	73	98	R1/8"	-	-	FLE215	UK215G2H	H2315	-	-	66,0	49,5	5,7	
70	EXFLE214	160	258	216	57	18	89,6	38	21	34,1	-	68,2	85,7	96,8	R1/8"	-	-	FLE214	EX214G2	-	-	-	62,0	45,0	6,0	70
	UCFLE214	160	258	216	57	18	82,4	38	21	30,2	-	74,6	-	-	R1/8"	-	-	FLE214	UC214G2	-	-	-	62,0	45,0	5,5	
75	EXFLE215	160	258	216	57	18	92,8	38	21	37,3	-	74,6	92,1	102	R1/8"	-	-	FLE215	EX215G2	-	-	-	66,0	49,5	5,8	75
	UCFLE215	160	258	216	57	18	82,5	38	21	33,3	-	77,8	-	-	R1/8"	-	-	FLE215	UC215G2	-	-	-	66,0	49,5	5,2	

* Bearing units that are ordered with cover(s) include the housings with grooves.
If you want to install the protective covers later, housings with suffix N must be ordered (for example: P210N).

Summary

CAST IRON HOUSINGS WITH CHROME STEEL BEARING INSERTS

FLANGED UNITS

Two-bolt flange, oval design, heavy duty
FL3

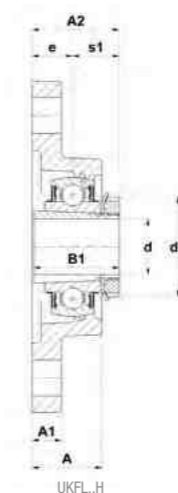
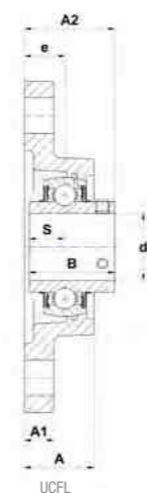
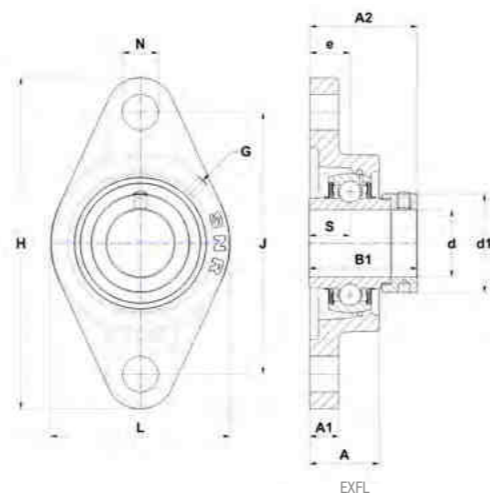

Main dimensions [mm]

d	Unit	L	H	J	A	A1	A2	e	N	S	s1	B	B1	d1	G	Housing	Bearing insert	Adapter sleeve	Dynamic load rating C [kN]	Static load rating C0 [kN]	Weight [kg]	d
20	UKFL305H	80	150	113	29	13	37,5	16	19	-	21,5	27	35	38	M6x1	FL305	UK305G2H	H2305	22,4	11,5	1,1	20
25	EXFL305	80	150	113	29	13	46,1	16	19	16,7	-	34,9	46,8	42,8	M6x1	FL305	EX305G2	-	22,4	11,5	1,0	25
	UCFL305	80	150	113	29	13	39	16	19	15	-	38	-	-	M6x1	FL305	UC305G2	-	22,4	11,5	0,9	
	UKFL306H	90	180	134	32	15	41	18	23	-	23	30	38	45	M6x1	FL306	UK306G2H	H2306	27,0	15,2	1,4	
30	EXFL306	90	180	134	32	15	50,5	18	23	17,5	-	36,5	50	50	M6x1	FL306	EX306G2	-	27,0	15,2	1,5	30
	UCFL306	90	180	134	32	15	44	18	23	17	-	43	-	-	M6x1	FL306	UC306G2	-	27,0	15,2	1,4	
	UKFL307H	100	185	141	36	16	45,5	20	23	-	25,5	33	43	52	M6x1	FL307	UK307G2H	H2307	33,5	19,2	1,9	
35	EXFL307	100	185	141	36	16	53,3	20	23	18,3	-	38,1	51,6	55	M6x1	FL307	EX307G2	-	33,5	19,2	1,8	35
	UCFL307	100	185	141	36	16	49	20	23	19	-	48	-	-	M6x1	FL307	UC307G2	-	33,5	19,2	1,7	
	UKFL308H	112	200	158	40	17	50,5	23	23	-	27,5	35	46	58	M6x1	FL308	UK308G2H	H2308	40,6	24,0	2,3	
40	EXFL308	112	200	158	40	17	60,3	23	23	19,8	-	41,3	57,1	63,5	M6x1	FL308	EX308G2	-	40,6	24,0	2,3	40
	UCFL308	112	200	158	40	17	56	23	23	19	-	52	-	-	M6x1	FL308	UC308G2	-	40,6	24,0	2,2	
	UKFL309H	125	230	177	44	18	55	25	25	-	30	38	50	65	M6x1	FL309	UK309G2H	H2309	53,0	31,8	3,3	
45	EXFL309	125	230	177	44	18	63,9	25	25	19,8	-	42,9	58,7	70	M6x1	FL309	EX309G2	-	53,0	31,8	3,3	45
	UCFL309	125	230	177	44	18	60	25	25	22	-	57	-	-	M6x1	FL309	UC309G2	-	53,0	31,8	3,1	
	UKFL310H	140	240	187	48	19	60	28	25	-	32	40	55	70	M6x1	FL310	UK310G2H	H2310	62,0	37,8	4,1	
50	EXFL310	140	240	187	48	19	70	28	25	24,6	-	49,2	66,6	76,2	M6x1	FL310	EX310G2	-	62,0	37,8	4,2	50
	UCFL310	140	240	187	48	19	67	28	25	22	-	61	-	-	M6x1	FL310	UC310G2	-	62,0	37,8	4,0	
	UKFL311H	150	250	198	52	20	64	30	25	-	34	43	59	75	M6x1	FL311	UK311G2H	H2311	71,5	44,8	4,9	
55	EXFL311	150	250	198	52	20	75,2	30	25	27,8	-	55,6	73	83	M6x1	FL311	EX311G2	-	71,5	44,8	5,0	55
	UCFL311	150	250	198	52	20	71	30	25	25	-	66	-	-	M6x1	FL311	UC311G2	-	71,5	44,8	4,6	
	UKFL312H	160	270	212	56	22	69,5	33	31	-	36,5	47	62	80	M6x1	FL312	UK312G2H	H2312	81,6	51,8	5,7	
60	EXFL312	160	270	212	56	22	81,4	33	31	31	-	61,9	79,4	89	M6x1	FL312	EX312G2	-	81,6	51,8	6,0	60
	UCFL312	160	270	212	56	22	78	33	31	26	-	71	-	-	M6x1	FL312	UC312G2	-	81,6	51,8	5,7	
	UKFL313H	175	295	240	58	25	71,5	33	31	-	38,5	49	65	85	M6x1	FL313	UK313G2H	H2313	93,9	60,5	7,3	
65	EXFL313	175	295	240	58	25	86,2	33	31	32,5	-	65,1	85,7	97	M6x1	FL313	EX313G2	-	93,9	60,5	7,7	65
	UCFL313	175	295	240	58	25	78	33	31	30	-	75	-	-	M6x1	FL313	UC313G2	-	93,9	60,5	7,3	
	UKFL315H	195	320	260	66	30	81,5	39	35	-	42,5	55	73	98	M10x1	FL315	UK315G2H	H2315	113,4	76,8	10,2	
70	EXFL314	185	315	250	61	28	93,9	36	35	34,2	-	68,3	92,1	102	M10x1	FL314	EX314G2	-	104,3	68,0	9,2	70
	UCFL314	185	315	250	61	28	81	36	35	33	-	78	-	-	M10x1	FL314	UC314G2	-	104,3	68,0	8,7	
	UKFL316H	210	355	285	68	32	82,5	38	38	-	44,5	55	78	105	M10x1	FL316	UK316G2H	H2316	122,9	86,5	12,7	
75	EXFL315	195	320	260	66	30	101,7	39	35	37,3	-	74,6	100	113	M10x1	FL315	EX315G2	-	113,4	76,8	10,5	75
	UCFL315	195	320	260	66	30	89	39	35	32	-	82	-	-	M10x1	FL315	UC315G2	-	113,4	76,8	9,5	
	UKFL317H	220	370	300	74	32	92	44	38	-	48	60	82	110	M10x1	FL317	UK317G2H	H2317	132,6	96,5	14,3	

CAST IRON HOUSINGS WITH CHROME STEEL BEARING INSERTS

FLANGED UNITS

Two-bolt flange, oval design, heavy duty
FL3

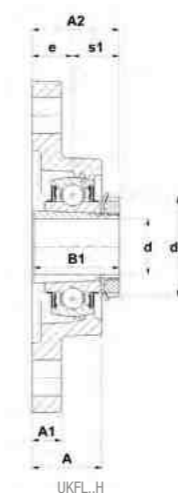
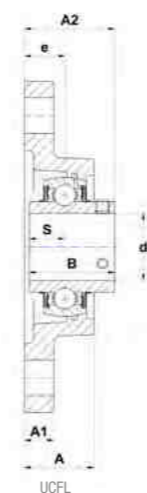
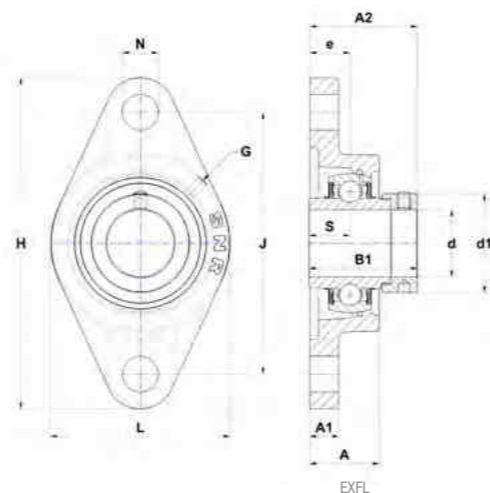

Main dimensions [mm]

d	Unit	L	H	J	A	A1	A2	e	N	S	s1	B	B1	d1	G	Housing	Bearing insert	Adapter sleeve	Dynamic load rating C [kN]	Static load rating C0 [kN]	Weight [kg]	d
80	EXFL316	210	355	285	68	32	103,9	38	38	40,5	-	81	106,4	119	M10x1	FL316	EX316G2	-	122,9	86,5	13,5	80
	UCFL316	210	355	285	68	32	90	38	38	34	-	86	-	-	M10x1	FL316	UC316G2	-	122,9	86,5	12,4	
	UKFL318H	235	385	315	76	36	92	44	38	-	48	60	86	120	M10x1	FL318	UK318G2H	H2318	143,0	108,0	17,0	
85	EXFL317	220	370	300	74	32	111,5	44	38	42	-	84,1	109,5	127	M10x1	FL317	EX317G2	-	132,6	96,5	15,4	85
	UCFL317	220	370	300	74	32	100	44	38	40	-	96	-	-	M10x1	FL317	UC317G2	-	132,6	96,5	14,3	
	UKFL319H	250	405	330	94	40	111	59	41	-	52	66	90	125	M10x1	FL319	UK319G2H	H2319	156,0	122,0	21,4	
90	EXFL318	235	385	315	76	36	116,3	44	38	43,6	-	87,3	115,9	133	M10x1	FL318	EX318G2	-	143,0	108,0	18,1	90
	UCFL318	235	385	315	76	36	100	44	38	40	-	96	-	-	M10x1	FL318	UC318G2	-	143,0	108,0	16,9	
	UKFL320H	270	440	360	94	40	113	59	44	-	54	68	97	130	M10x1	FL320	UK320G2H	H2320	171,6	140,0	25,7	
95	EXFL319	250	405	330	94	40	134,5	59	41	46,8	-	93,7	122,3	140	M10x1	FL319	EX319G2	-	156,0	122,0	22,6	95
	UCFL319	250	405	330	94	40	121	59	41	41	-	103	-	-	M10x1	FL319	UC319G2	-	156,0	122,0	21,1	
100	EXFL320	270	440	360	94	40	137,6	59	44	50	-	100	128,6	146	M10x1	FL320	EX320G2	-	171,6	140,0	27,7	100
	UCFL320	270	440	360	94	40	125	59	44	42	-	108	-	-	M10x1	FL320	UC320G2	-	171,6	140,0	26,1	
	UKFL322H	300	470	390	96	42	121	60	44	-	61	80	105	145	M10x1	FL322	UK322G2H	H2322	205,0	178,0	35,6	
105	UCFL321	270	440	360	94	40	127	59	44	44	-	112	-	-	M10x1	FL321	UC321G2	-	182,0	155,0	24,9	105
110	UCFL322	300	470	390	96	42	131	60	44	46	-	117	-	-	M10x1	FL322	UC322G2	-	205,0	178,0	32,3	110
	UKFL324H	330	520	430	110	48	130,5	65	47	-	65,5	87	112	155	M10x1	FL324	UK324G2H	H2324	228,0	208,0	47,4	
115	UKFL326H	360	550	460	115	50	133	65	47	-	68	90	121	165	M10x1	FL326	UK326G2H	H2326	252,0	242,0	60,8	115
120	UCFL324	330	520	430	110	48	140	65	47	51	-	126	-	-	M10x1	FL324	UC324G2	-	228,0	208,0	44,7	120
125	UKFL328H	400	600	500	125	60	148	75	51	-	73	98	131	180	M10x1	FL328	UK328G2H	H2328	275,0	272,0	82,9	125
130	UCFL326	360	550	460	115	50	146	65	47	54	-	135	-	-	M10x1	FL326	UC326G2	-	252,0	242,0	55,9	130
140	UCFL328	400	600	500	125	60	161	75	51	59	-	145	-	-	M10x1	FL328	UC328G2	-	275,0	272,0	76,9	140

CAST IRON HOUSINGS WITH CHROME STEEL BEARING INSERTS

FLANGED UNITS

Two-bolt flange with centering rim, oval design
FLZ2

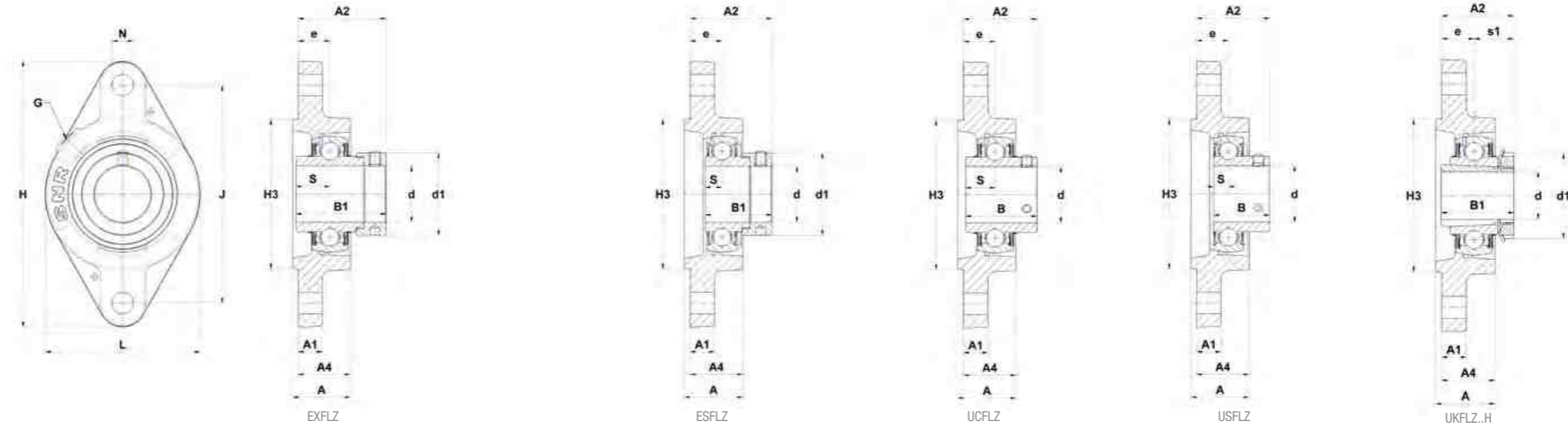

Main dimensions [mm]

d	Unit	L	H	J	A	A1	A2	A4	H3	e	N	S	s1	B	B1	d1	G	Housing	Bearing insert	Adapter sleeve	Dynamic load rating C [kN]	Static load rating C0 [kN]	Weight [kg]	d
12	ESFLZ201	60,5	112,5	90	32	10	41,1	28,5	55	19	11,5	6,5	-	19	28,6	27,2	R1/8"	FLZ203	ES201G2	-	9,6	4,8	0,5	12
	EXFLZ201	60,5	112,5	90	32	10	45,5	28,5	55	19	11,5	17	-	34	43,5	32,4	R1/8"	FLZ204	EX201G2	-	12,8	6,7	0,6	
	UCFLZ201	60,5	112,5	90	32	10	37,3	28,5	55	19	11,5	12,7	-	31	-	-	R1/8"	FLZ204	UC201G2	-	12,8	6,7	0,5	
	USFLZ201	60,5	112,5	90	32	10	35	28,5	55	19	11,5	6	-	22	-	-	R1/8"	FLZ203	US201G2	-	9,6	4,8	0,5	
15	ESFLZ202	60,5	112,5	90	32	10	41,1	28,5	55	19	11,5	6,5	-	19,1	28,6	27,2	R1/8"	FLZ203	ES202G2	-	9,6	4,8	0,5	15
	EXFLZ202	60,5	112,5	90	32	10	45,5	28,5	55	19	11,5	17	-	34	43,5	32,4	R1/8"	FLZ204	EX202G2	-	12,8	6,7	0,6	
	UCFLZ202	60,5	112,5	90	32	10	37,3	28,5	55	19	11,5	12,7	-	31	-	-	R1/8"	FLZ204	UC202G2	-	12,8	6,7	0,5	
	USFLZ202	60,5	112,5	90	32	10	35	28,5	55	19	11,5	6	-	22	-	-	R1/8"	FLZ203	US202G2	-	9,6	4,8	0,5	
17	ESFLZ203	60,5	112,5	90	32	10	41,1	28,5	55	19	11,5	6,5	-	19,1	28,6	27,2	R1/8"	FLZ203	ES203G2	-	9,6	4,8	0,5	17
	EXFLZ203	60,5	112,5	90	32	10	45,5	28,5	55	19	11,5	17	-	34	43,5	32,4	R1/8"	FLZ204	EX203G2	-	12,8	6,7	0,6	
	UCFLZ203	60,5	112,5	90	32	10	37,3	28,5	55	19	11,5	12,7	-	31	-	-	R1/8"	FLZ204	UC203G2	-	12,8	6,7	0,5	
	USFLZ203	60,5	112,5	90	32	10	35	28,5	55	19	11,5	6	-	22	-	-	R1/8"	FLZ203	US203G2	-	9,6	4,8	0,5	
20	ESFLZ204	60,5	112,5	90	32	10	42,4	28,5	55	19	11,5	7,5	-	21,4	30,9	32,4	R1/8"	FLZ204	ES204G2	-	12,8	6,7	0,5	20
	EXFLZ204	60,5	112,5	90	32	10	45,5	28,5	55	19	11,5	17	-	34	43,5	32,4	R1/8"	FLZ204	EX204G2	-	12,8	6,7	0,5	
	UCFLZ204	60,5	112,5	90	32	10	37,3	28,5	55	19	11,5	12,7	-	31	-	-	R1/8"	FLZ204	UC204G2	-	12,8	6,7	0,5	
	UKFLZ205H	70	124	99	32,5	12	37,5	29	60	19	11,5	-	18,5	21	35	38	R1/8"	FLZ205	UK205G2H	H2305	14,0	7,9	0,7	
	USFLZ204	60,5	112,5	90	32	10	37	28,5	55	19	11,5	7	-	25	-	-	R1/8"	FLZ204	US204G2	-	12,8	6,7	0,4	
25	ESFLZ205	70	124	99	32,5	12	42,4	29	60	19	11,5	7,5	-	21,4	30,9	37,4	R1/8"	FLZ205	ES205G2	-	14,0	7,9	0,7	25
	EXFLZ205	70	124	99	32,5	12	45,9	29	60	19	11,5	17,4	-	34,8	44,3	37,4	R1/8"	FLZ205	EX205G2	-	14,0	7,9	0,8	
	UCFLZ205	70	124	99	32,5	12	38,7	29	60	19	11,5	14,3	-	34	-	-	R1/8"	FLZ205	UC205G2	-	14,0	7,9	0,7	
	UKFLZ206H	83	142	116,5	30	12	37,5	27	80	17	11,5	-	20,5	25	38	45	R1/8"	FLZ206	UK206G2H	H2306	19,5	11,2	1,0	
	USFLZ205	70	124	99	32,5	12	38,5	29	60	19	11,5	7,5	-	27	-	-	R1/8"	FLZ205	US205G2	-	14,0	7,9	0,7	
30	ESFLZ206	83	142	116,5	30	12	43,7	27	80	17	11,5	9	-	23,8	35,7	44,1	R1/8"	FLZ206	ES206G2	-	19,5	11,2	0,9	30
	EXFLZ206	83	142	116,5	30	12	47,1	27	80	17	11,5	18,2	-	36,4	48,3	44,1	R1/8"	FLZ206	EX206G2	-	19,5	11,2	1,0	
	UCFLZ206	83	142	116,5	30	12	39,2	27	80	17	11,5	15,9	-	38,1	-	-	R1/8"	FLZ206	UC206G2	-	19,5	11,2	0,9	
	UKFLZ207H	94	155	130	32,5	12,5	39,5	28,5	90	17	14	-	22,5	27	43	52	R1/8"	FLZ207	UK207G2H	H2307	25,7	15,2	1,3	
	USFLZ206	83	142	116,5	30	12	39	27	80	17	11,5	8	-	30	-	-	R1/8"	FLZ206	US206G2	-	19,5	11,2	0,9	
35	ESFLZ207	94	155	130	32,5	12,5	46,4	28,5	90	17	14	9,5	-	25,4	38,9	51,1	R1/8"	FLZ207	ES207G2	-	25,7	15,2	1,3	35
	EXFLZ207	94	155	130	32,5	12,5	49,3	28,5	90	17	14	18,8	-	37,6	51,1	51,1	R1/8"	FLZ207	EX207G2	-	25,7	15,2	1,4	
	UCFLZ207	94	155	130	32,5	12,5	42,4	28,5	90	17	14	17,5	-	42,9	-	-	R1/8"	FLZ207	UC207G2	-	25,7	15,2	1,3	
	UKFLZ208H	105	172	143,5	36	13	44,5	32	100	20	14	-	24,5	29	46	58	R1/8"	FLZ208	UK208G2H	H2308	29,6	18,2	1,8	
	USFLZ207	94	155	130	32,5	12,5	40,5	28,5	90	17	14	8,5	-	32	-	-	R1/8"	FLZ207	US207G2	-	25,7	15,2	1,2	

CAST IRON HOUSINGS WITH CHROME STEEL BEARING INSERTS

FLANGED UNITS

Two-bolt flange with centering rim, oval design
FLZ2

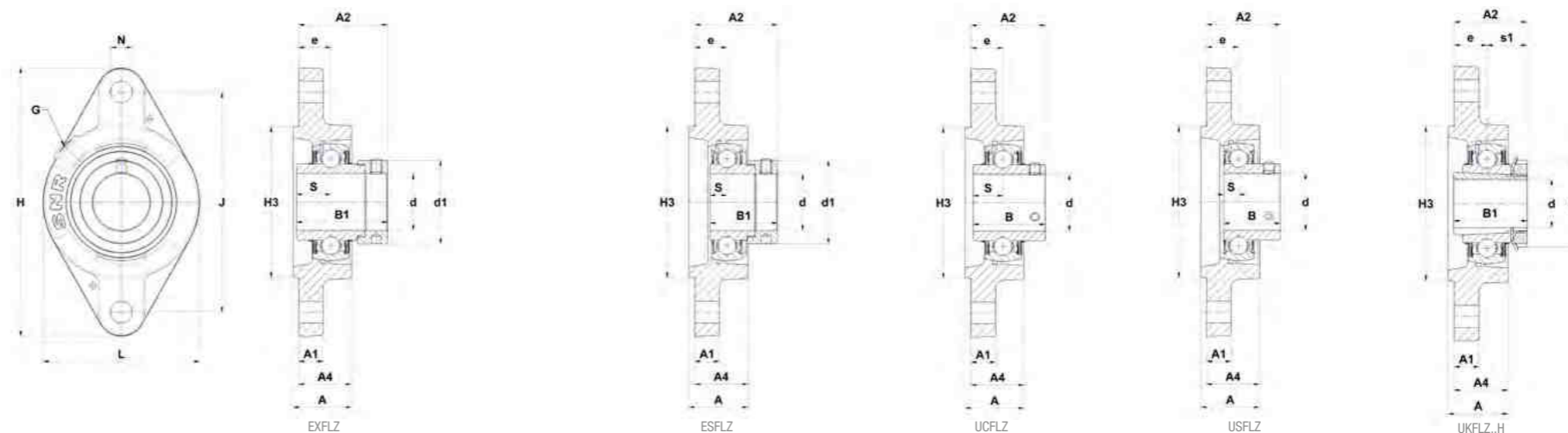

Main dimensions [mm]

d	Unit	L	H	J	A	A1	A2	A4	H3	e	N	S	s1	B	B1	d1	G	Housing	Bearing insert	Adapter sleeve	Dynamic load rating C [kN]	Static load rating C0 [kN]	Weight [kg]	d
40	ESFLZ208	105	172	143,5	36	13	52,7	32	100	20	14	11	-	30,2	43,7	58	R1/8"	FLZ208	ES208G2	-	29,6	18,2	1,8	40
	EXFLZ208	105	172	143,5	36	13	54,9	32	100	20	14	21,4	-	42,8	56,3	58	R1/8"	FLZ208	EX208G2	-	29,6	18,2	1,9	
	UCFLZ208	105	172	143,5	36	13	50,2	32	100	20	14	19	-	49,2	-	-	R1/8"	FLZ208	UC208G2	-	29,6	18,2	1,7	
	UKFLZ209H	111	180	148,5	36,5	13	46	32,5	105	20	14	-	26	30	50	65	R1/8"	FLZ209	UK209G2H	H2309	31,9	20,8	2,0	
	USFLZ208	105	172	143,5	36	13	45	32	100	20	14	9	-	34	-	-	R1/8"	FLZ208	US208G2	-	29,6	18,2	1,7	
45	ESFLZ209	111	180	148,5	36,5	13	52,7	32,5	105	20	14	11	-	30,2	43,7	62	R1/8"	FLZ209	ES209G2	-	31,9	20,8	1,9	45
	EXFLZ209	111	180	148,5	36,5	13	54,9	32,5	105	20	14	21,4	-	42,8	56,3	62	R1/8"	FLZ209	EX209G2	-	31,9	20,8	2,1	
	UCFLZ209	111	180	148,5	36,5	13	50,2	32,5	105	20	14	19	-	49,2	-	-	R1/8"	FLZ209	UC209G2	-	31,9	20,8	1,9	
	UKFLZ210H	116	190	157	41	13	51,5	37	105	24	14	-	27,5	31	55	70	R1/8"	FLZ210	UK210G2H	H2310	35,1	23,2	2,3	
	USFLZ209	111	180	148,5	36,5	13	51	32,5	105	20	14	10,2	-	41,2	-	-	R1/8"	FLZ209	US209G2	-	31,9	20,8	1,9	
50	ESFLZ210	116	190	157	41	13	56,7	37	105	24	14	11	-	30,2	43,7	67,2	R1/8"	FLZ210	ES210G2	-	35,1	23,2	2,1	50
	EXFLZ210	116	190	157	41	13	62,1	37	105	24	14	24,6	-	49,2	62,7	67,2	R1/8"	FLZ210	EX210G2	-	35,1	23,2	2,3	
	UCFLZ210	116	190	157	41	13	56,6	37	105	24	14	19	-	51,6	-	-	R1/8"	FLZ210	UC210G2	-	35,1	23,2	2,1	
	USFLZ210	116	190	157	41	13	56,6	37	105	24	14	10,9	-	43,5	-	-	R1/8"	FLZ210	US210G2	-	35,1	23,2	2,1	
55	UKFLZ212H	138	238	202	49	16	61	45	130	30	18	-	31	36	62	80	R1/8"	FLZ212	UK212G2H	H2312	52,5	32,8	3,7	55
60	ESFLZ212	138	238	202	49	16	67,3	45	130	30	18	12	-	33,4	49,3	82	R1/8"	FLZ212	ES212G2	-	52,5	32,8	3,4	60
	EXFLZ212	138	238	202	49	16	76,8	45	130	30	18	30,9	-	61,8	77,7	82	R1/8"	FLZ212	EX212G2	-	52,5	32,8	4,1	
	UCFLZ212	138	238	202	49	16	69,7	45	130	30	18	25,4	-	65,1	-	-	R1/8"	FLZ212	UC212G2	-	52,5	32,8	3,7	
	USFLZ212	138	238	202	49	16	68,8	45	130	30	18	14,9	-	53,7	-	-	R1/8"	FLZ212	US212G2	-	52,5	32,8	3,5	

CAST IRON HOUSINGS WITH CHROME STEEL BEARING INSERTS

FLANGED UNITS

Two-bolt flange, oval narrow design

FD2

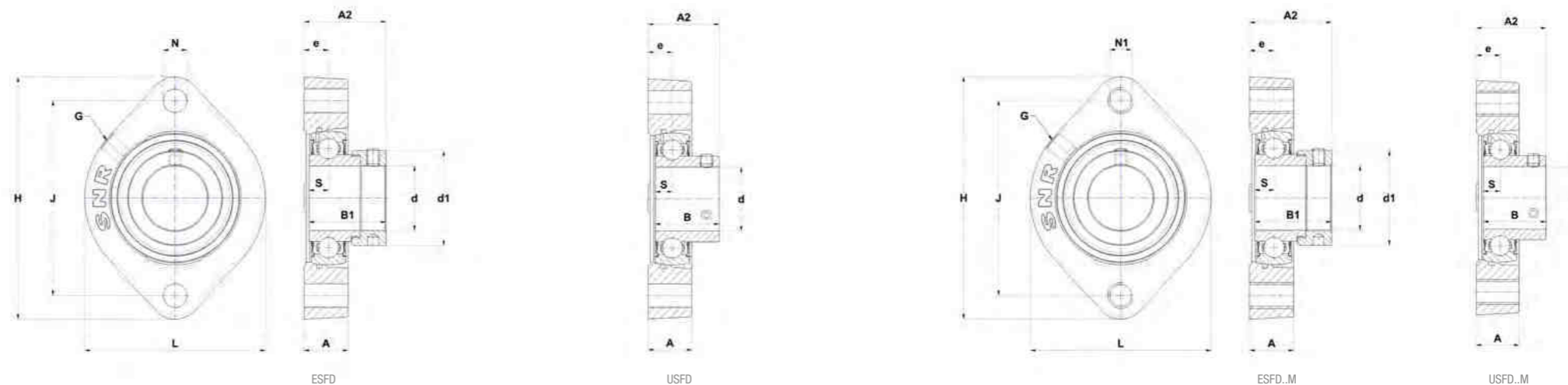

Main dimensions [mm]

d	Unit	L	H	J	A	A2	e	N	N1	S	B	B1	d1	G	Housing	Bearing insert	Dynamic load rating C [kN]	Static load rating C0 [kN]	Weight [kg]	d
12	ESFD201M6	58,7	81	63,5	15	30,5	8,4	-	M6	6,5	19	28,6	27,2	M6x1	FD203G	ES201G2	9,6	4,8	0,3	12
	USFD201M6	58,7	81	63,5	15	24,4	8,4	-	M6	6	22	-	-	M6x1	FD203G	US201G2	9,6	4,8	0,3	
15	ESFD202	58,7	81	63,5	15	30,5	8,4	6,5	-	6,5	19,1	28,6	27,2	M6x1	FD203	ES202G2	9,6	4,8	0,3	15
	ESFD202M6	58,7	81	63,5	15	30,5	8,4	-	M6	6,5	19,1	28,6	27,2	M6x1	FD203G	ES202G2	9,6	4,8	0,3	
	USFD202	58,7	81	63,5	15	24,4	8,4	6,5	-	6	22	-	-	M6x1	FD203	US202G2	9,6	4,8	0,3	
	USFD202M6	58,7	81	63,5	15	24,4	8,4	-	M6	6	22	-	-	M6x1	FD203G	US202G2	9,6	4,8	0,3	
17	ESFD203	58,7	81	63,5	15	30,5	8,4	6,5	-	6,5	19,1	28,6	27,2	M6x1	FD203	ES203G2	9,6	4,8	0,3	17
	ESFD203M6	58,7	81	63,5	15	30,5	8,4	-	M6	6,5	19,1	28,6	27,2	M6x1	FD203G	ES203G2	9,6	4,8	0,3	
	USFD203	58,7	81	63,5	15	24,4	8,4	6,5	-	6	22	-	-	M6x1	FD203	US203G2	9,6	4,8	0,3	
	USFD203M6	58,7	81	63,5	15	24,4	8,4	-	M6	6	22	-	-	M6x1	FD203G	US203G2	9,6	4,8	0,3	
20	ESFD204	66,5	90,5	71,4	17	32,9	9,5	9	-	7,5	21,4	30,9	32,4	M6x1	FD204	ES204G2	12,8	6,7	0,4	20
	ESFD204M10	66,5	90,5	71,4	17	32,9	9,5	-	M10	7,5	21,4	30,9	32,4	M6x1	FD204G	ES204G2	12,8	6,7	0,5	
	USFD204	66,5	90,5	71,4	17	27,5	9,5	9	-	7	25	-	-	M6x1	FD204	US204G2	12,8	6,7	0,3	
	USFD204M10	66,5	90,5	71,4	17	27,5	9,5	-	M10	7	25	-	-	M6x1	FD204G	US204G2	12,8	6,7	0,4	
25	ESFD205	71	97	76,2	17,5	33,3	9,9	9	-	7,5	21,4	30,9	37,4	M6x1	FD205	ES205G2	14,0	7,9	0,5	25
	ESFD205M12	71	97	76,2	17,5	33,3	9,9	-	M12	7,5	21,4	30,9	37,4	M6x1	FD205G	ES205G2	14,0	7,9	0,5	
	USFD205	71	97	76,2	17,5	29,4	9,9	9	-	7,5	27	-	-	M6x1	FD205	US205G2	14,0	7,9	0,5	
	USFD205M12	71	97	76,2	17,5	29,4	9,9	-	M12	7,5	27	-	-	M6x1	FD205G	US205G2	14,0	7,9	0,5	
30	ESFD206	84	112,5	90,5	20,5	38,1	11,4	11	-	9	23,8	35,7	44,1	R1/8"	FD206	ES206G2	19,5	11,2	0,7	30
	ESFD206M12	84	112,5	90,5	20,5	38,1	11,4	-	M12	9	23,8	35,7	44,1	R1/8"	FD206G	ES206G2	19,5	11,2	0,7	
	USFD206	84	112,5	90,5	20,5	33,4	11,4	11	-	8	30	-	-	R1/8"	FD206	US206G2	19,5	11,2	0,7	
	USFD206M12	84	112,5	90,5	20,5	33,4	11,4	-	M12	8	30	-	-	R1/8"	FD206G	US206G2	19,5	11,2	0,7	
35	ESFD207	94	126	100	22	41,8	12,4	11	-	9,5	25,4	38,9	51,1	R1/8"	FD207	ES207G2	25,7	15,2	1,0	35
	ESFD207M12	94	126	100	22	41,8	12,4	-	M12	9,5	25,4	38,9	51,1	R1/8"	FD207G	ES207G2	25,7	15,2	1,0	
	USFD207	94	126	100	22	35,9	12,4	11	-	8,5	32	-	-	R1/8"	FD207	US207G2	25,7	15,2	0,9	
	USFD207M12	94	126	100	22	35,9	12,4	-	M12	8,5	32	-	-	R1/8"	FD207G	US207G2	25,7	15,2	0,9	
40	ESFD208	104	148	119	24	44,75	12,05	14	-	11	30,2	43,7	58	R1/8"	FD208	ES208G2	29,6	18,2	1,5	40
	ESFD208M12	104	148	119	24	44,75	12,05	-	M12	11	30,2	43,7	58	R1/8"	FD208G	ES208G2	29,6	18,2	1,5	
	USFD208	104	148	119	24	37,05	12,05	14	-	9	34	-	-	R1/8"	FD208	US208G2	29,6	18,2	1,4	
	USFD208M12	104	148	119	24	37,05	12,05	-	M12	9	34	-	-	R1/8"	FD208G	US208G2	29,6	18,2	1,4	

CAST IRON HOUSINGS WITH CHROME STEEL BEARING INSERTS

FLANGED UNITS

Two-bolt flange with long hole for shaft adjustment, oval design

FAE2

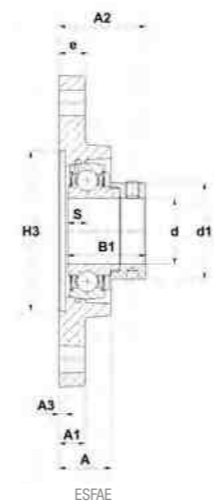
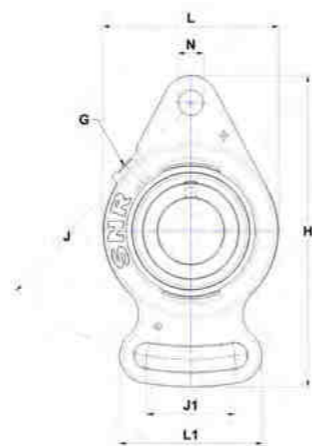

Main dimensions [mm]

d	Unit	L	L1	H3 +0,2	H3	J	J1	A	A1	A2	A3 +0,2	e	N	S	B	B1	d1	G	Housing	Bearing insert	Dynamic load rating C [kN]	Static load rating C0 [kN]	Weight [kg]	d
20	ESFAE204	61	52	112	50,8	90	30	20	10	33,9	2	10,5	11,5	7,5	21,4	30,9	32,4	R1/8"	FAE204	ES204G2	12,8	6,7	0,5	20
	USFAE204	61	52	112	50,8	90	30	20	10	28,5	2	10,5	11,5	7	25	-	-	R1/8"	FAE204	US204G2	12,8	6,7	0,4	
25	ESFAE205	70	63	124	63,5	99	37,5	22,5	11	35,9	3,5	12,5	11,5	7,5	21,4	30,9	37,4	R1/8"	FAE205	ES205G2	14,0	7,9	0,6	25
	USFAE205	70	63	124	63,5	99	37,5	22,5	11	32	3,5	12,5	11,5	7,5	27	-	-	R1/8"	FAE205	US205G2	14,0	7,9	0,6	
30	ESFAE206	80	65	142	73	117	40	24	12	39,7	3	13	11,5	9	23,8	35,7	44,1	R1/8"	FAE206	ES206G2	19,5	11,2	0,8	30
	USFAE206	80	65	142	73	117	40	24	12	35	3	13	11,5	8	30	-	-	R1/8"	FAE206	US206G2	19,5	11,2	0,8	
35	ESFAE207	90	75	155	82,5	128	45	26,5	12,5	44,4	4,5	15	14	9,5	25,4	38,9	51,1	R1/8"	FAE207	ES207G2	25,7	15,2	1,1	35
	USFAE207	90	75	155	82,5	128	45	26,5	12,5	38,5	4,5	15	14	8,5	32	-	-	R1/8"	FAE207	US207G2	25,7	15,2	1,0	

CAST IRON HOUSINGS WITH CHROME STEEL BEARING INSERTS

FLANGED UNITS

Two-bolt flange with long hole for shaft adjustment, oval design

FA2

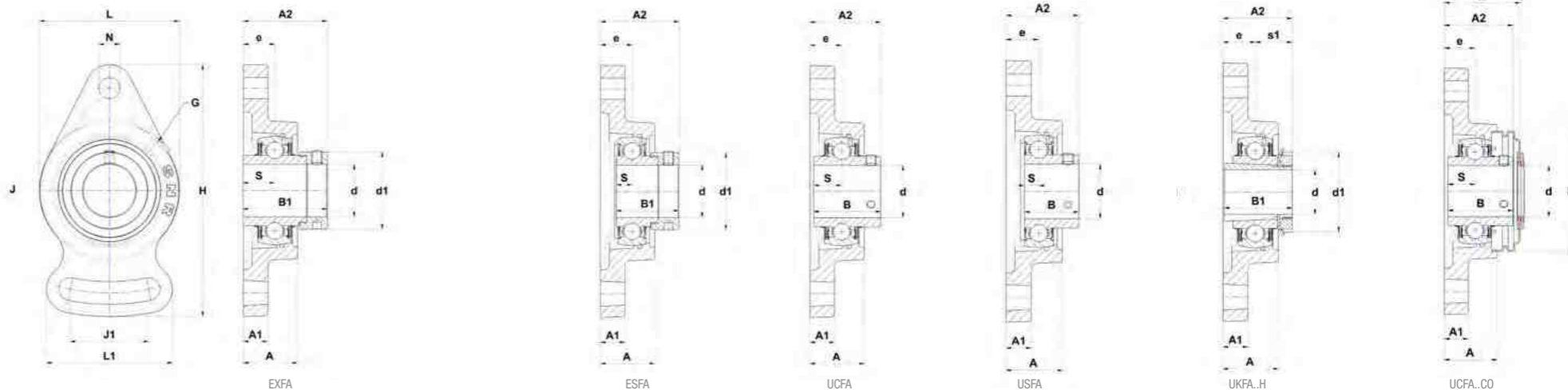

Main dimensions [mm]

d	Unit	L	L1	H	J	J1	A	A1	A2	e	N	S	s1	B	B1	d1	G	Z	Dz	Housing	Bearing insert	Adapter sleeve	Open protective cap*	Closed protective cap*	Dynamic load rating C [kN]	Static load rating C0 [kN]	Weight [kg]	d
12	ESFA201	60	54	102	78	40	25,5	12	37,1	15	10	6,5	-	19	28,6	27,2	M6x1	41,5	46	FA203	ES201G2	-	SCOE201-12	SCCE203	9,6	4,8	0,3	12
	EXFA201	60	54	102	78	40	25,5	12	41,5	15	10	17	-	34	43,5	32,4	M6x1	46,2	54	FA204	EX201G2	-	SCOE204-12	SCCE204	12,8	6,7	0,6	
	UCFA201	60	54	102	78	40	25,5	12	33,3	15	10	12,7	-	31	-	-	M6x1	37	54	FA204	UC201G2	-	SCO204-12	SCC204	12,8	6,7	0,5	
	USFA201	60	54	102	78	40	25,5	12	31	15	10	6	-	22	-	-	M6x1	34,8	46	FA203	US201G2	-	SCO201-12	SCC203	9,6	4,8	0,3	
15	ESFA202	60	54	102	78	40	25,5	12	37,1	15	10	6,5	-	19,1	28,6	27,2	M6x1	41,5	46	FA203	ES202G2	-	SCOE202-15	SCCE203	9,6	4,8	0,3	15
	EXFA202	60	54	102	78	40	25,5	12	41,5	15	10	17	-	34	43,5	32,4	M6x1	46,2	54	FA204	EX202G2	-	SCOE204-15	SCCE204	12,8	6,7	0,6	
	UCFA202	60	54	102	78	40	25,5	12	33,3	15	10	12,7	-	31	-	-	M6x1	37	54	FA204	UC202G2	-	SCO204-15	SCC204	12,8	6,7	0,5	
	USFA202	60	54	102	78	40	25,5	12	31	15	10	6	-	22	-	-	M6x1	34,8	46	FA203	US202G2	-	SCO202-15	SCC203	9,6	4,8	0,3	
17	ESFA203	60	54	102	78	40	25,5	12	37,1	15	10	6,5	-	19,1	28,6	27,2	M6x1	41,5	46	FA203	ES203G2	-	SCOE203-17	SCCE203	9,6	4,8	0,3	17
	EXFA203	60	54	102	78	40	25,5	12	41,5	15	10	17	-	34	43,5	32,4	M6x1	46,2	54	FA204	EX203G2	-	SCOE204-17	SCCE204	12,8	6,7	0,6	
	UCFA203	60	54	102	78	40	25,5	12	33,3	15	10	12,7	-	31	-	-	M6x1	37	54	FA204	UC203G2	-	SCO204-17	SCC204	12,8	6,7	0,5	
	USFA203	60	54	102	78	40	25,5	12	31	15	10	6	-	22	-	-	M6x1	34,8	46	FA203	US203G2	-	SCO203-17	SCC203	9,6	4,8	0,3	
20	ESFA204	60	54	102	78	40	25,5	12	38,4	15	10	7,5	-	21,4	30,9	32,4	M6x1	46,2	54	FA204	ES204G2	-	SCOE204-20	SCCE204	12,8	6,7	0,5	20
	EXFA204	60	54	102	78	40	25,5	12	41,5	15	10	17	-	34	43,5	32,4	M6x1	46,2	54	FA204	EX204G2	-	SCOE204-20	SCCE204	12,8	6,7	0,5	
	UCFA204	60	54	102	78	40	25,5	12	33,3	15	10	12,7	-	31	-	-	M6x1	37	54	FA204	UC204G2	-	SCO204-20	SCC204	12,8	6,7	0,5	
	UKFA205H	68	65	125	98	51	27	14	34,5	16	12	-	18,5	21	35	38	M6x1	39,6	60	FA205	UK205G2H	H2305	SCO205-20	SCC205	14,0	7,9	0,6	
	USFA204	60	54	102	78	40	25,5	12	33	15	10	7	-	25	-	-	M6x1	37	54	FA204	US204G2	-	SCO204-20	SCC204	12,8	6,7	0,4	
25	ESFA205	68	65	125	98	51	27	14	39,4	16	12	7,5	-	21,4	30,9	37,4	M6x1	48,2	60	FA205	ES205G2	-	SCOE205-25	SCCE205	14,0	7,9	0,6	25
	EXFA205	68	65	125	98	51	27	14	42,9	16	12	17,4	-	34,8	44,3	37,4	M6x1	48,2	60	FA205	EX205G2	-	SCOE205-25	SCCE205	14,0	7,9	0,7	
	UCFA205	68	65	125	98	51	27	14	35,7	16	12	14,3	-	34	-	-	M6x1	39,6	60	FA205	UC205G2	-	SCO205-25	SCC205	14,0	7,9	0,6	
	UKFA206H	80	72	144	117	58	31	14	38,5	18	12	-	20,5	25	38	45	M6x1	44,4	70	FA206	UK206G2H	H2306	SCO206-25	SCC206	19,5	11,2	1,0	
	USFA205	68	65	125	98	51	27	14	35,5	16	12	7,5	-	27	-	-	M6x1	39,6	60	FA205	US205G2	-	SCO205-25	SCC205	14,0	7,9	0,6	
30	ESFA206	80	72	144	117	58	31	14	44,7	18	12	9	-	23,8	35,7	44,1	M6x1	53,5	70	FA206	ES206G2	-	SCOE206-30	SCCE206	19,5	11,2	0,9	30
	EXFA206	80	72	144	117	58	31	14	48,1	18	12	18,2	-	36,4	48,3	44,1	M6x1	53,5	70	FA206	EX206G2	-	SCOE206-30	SCCE206	19,5	11,2	1,0	
	UCFA206	80	72	144	117	58	31	14	40,2	18	12	15,9	-	38,1	-	-	M6x1	44,4	70	FA206	UC206G2	-	SCO206-30	SCC206	19,5	11,2	0,9	
	UKFA207H	90	82	161	130	66	34	16	41,5	19	15	-	22,5	27	43	52	M6x1	48,7	80	FA207	UK207G2H	H2307	SCO207-30	SCC207	25,7	15,2	1,3	
	USFA206	80	72	144	117	58	31	14	40	18	12	8	-	30	-	-	M6x1	44,4	70	FA206	US206G2	-	SCO206-30	SCC206	19,5	11,2	0,9	
35	ESFA207	90	82	161	130	66	34	16	48,4	19	15	9,5	-	25,4	38,9	51,1	M6x1	58	80	FA207	ES207G2	-	SCOE207-35	SCCE207	25,7	15,2	1,3	35
	EXFA207	90	82	161	130	66	34	16	51,3	19	15	18,8	-	37,6	51,1	51,1	M6x1	58	80	FA207	EX207G2	-	SCOE207-35	SCCE207	25,7	15,2	1,4	
	UCFA207	90	82	161	130	66	34	16	44,4	19	15	17,5	-	42,9	-	-	M6x1	48,7	80	FA207	UC207G2	-	SCO207-35	SCC207	25,7	15,2	1,3	
	UKFA208H	100	87	175	144	71	36	16	45,5	21	15	-	24,5	29	46	58	M6x1	55,7	88	FA208	UK208G2H	H2308	SCO208-35	SCC208	29,6	18,2	1,7	
	USFA207	90	82	161	130	66	34	16	42,5	19	15	8,5	-	32	-	-	M6x1	48,7	80	FA207	US207G2	-	SCO207-35	SCC207	25,7	15,2	1,2	

* Bearing units that are ordered with cover(s) include the housings with grooves.
If you want to install the protective covers later, housings with suffix N must be ordered (for example: P210N).

CAST IRON HOUSINGS WITH CHROME STEEL BEARING INSERTS

FLANGED UNITS

Two-bolt flange with long hole for shaft adjustment, oval design

FA2

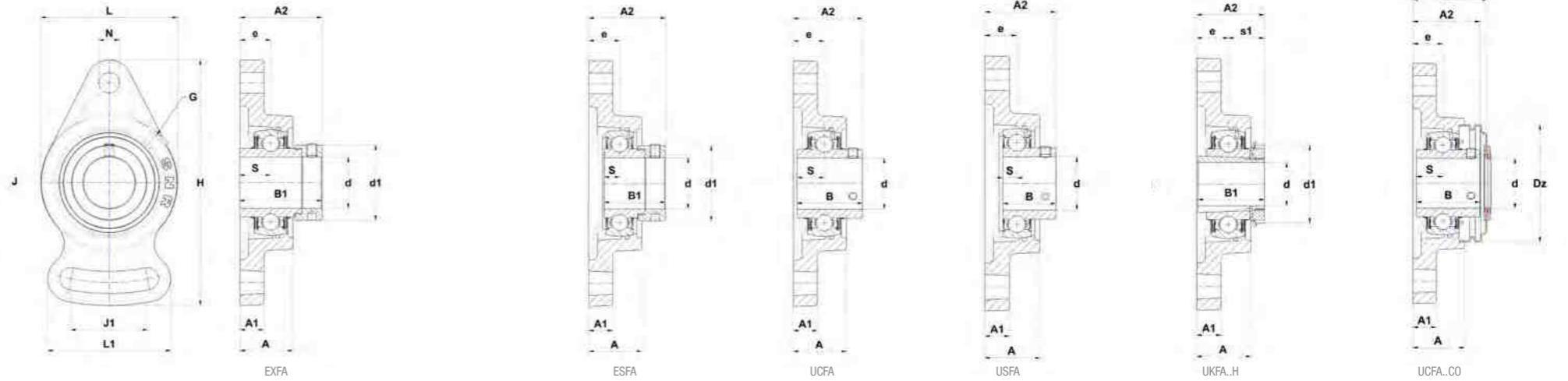

Main dimensions [mm]

d	Unit	L	L1	H	J	J1	A	A1	A2	e	N	S	s1	B	B1	d1	G	Z	Dz	Housing	Bearing insert	Adapter sleeve	Open protective cap*	Closed protective cap*	Dynamic load rating C [kN]	Static load rating C0 [kN]	Weight [kg]	d
40	ESFA208	100	87	175	144	71	36	16	53,7	21	15	11	-	30,2	43,7	58	M6x1	61,8	88	FA208	ES208G2	-	SCOE208-40	SCCE208	29,6	18,2	1,7	40
	EXFA208	100	87	175	144	71	36	16	55,9	21	15	21,4	-	42,8	56,3	58	M6x1	61,8	88	FA208	EX208G2	-	SCOE208-40	SCCE208	29,6	18,2	1,8	
	UCFA208	100	87	175	144	71	36	16	51,2	21	15	19	-	49,2	-	-	M6x1	55,7	88	FA208	UC208G2	-	SC0208-40	SCC208	29,6	18,2	1,6	
	UKFA209H	108	90	181	148	72	38	18	48	22	15	-	26	30	50	65	M6x1	57,7	95	FA209	UK209G2H	H2309	SC0209-40	SCC209	31,9	20,8	2,0	
	USFA208	100	87	175	144	71	36	16	46	21	15	9	-	34	-	-	M6x1	55,7	88	FA208	US208G2	-	SC0208-40	SCC208	29,6	18,2	1,6	
45	ESFA209	108	90	181	148	72	38	18	54,7	22	15	11	-	30,2	43,7	62	M6x1	64,8	95	FA209	ES209G2	-	SCOE209-45	SCCE209	31,9	20,8	1,9	45
	EXFA209	108	90	181	148	72	38	18	56,9	22	15	21,4	-	42,8	56,3	62	M6x1	64,8	95	FA209	EX209G2	-	SCOE209-45	SCCE209	31,9	20,8	2,1	
	UCFA209	108	90	181	148	72	38	18	52,2	22	15	19	-	49,2	-	-	M6x1	57,7	95	FA209	UC209G2	-	SC0209-45	SCC209	31,9	20,8	1,9	
	UKFA210H	115	94	190	157	76	40	18	49,5	22	15	-	27,5	31	55	70	M6x1	59,8	100	FA210	UK210G2H	H2310	SC0210-45	SCC210	35,1	23,2	2,4	
	USFA209	108	90	181	148	72	38	18	53	22	15	10,2	-	41,2	-	-	M6x1	55,7	95	FA209	US209G2	-	SC0209-45	SCC209	31,9	20,8	1,9	
50	ESFA210	115	94	190	157	76	40	18	54,7	22	15	11	-	30,2	43,7	67,2	M6x1	67,5	100	FA210	ES210G2	-	SCOE210-50	SCCE210	35,1	23,2	2,2	50
	EXFA210	115	94	190	157	76	40	18	60,1	22	15	24,6	-	49,2	62,7	67,2	M6x1	67,5	100	FA210	EX210G2	-	SCOE210-50	SCCE210	35,1	23,2	2,4	
	UCFA210	115	94	190	157	76	40	18	54,6	22	15	19	-	51,6	-	-	M6x1	59,8	100	FA210	UC210G2	-	SC0210-50	SCC210	35,1	23,2	2,2	
	UKFA211H	130	104	219	184	86	43	20	54	25	16	-	29	33	59	75	M6x1	64,4	110	FA211	UK211G2H	H2311	SC0211-50	SCC211	43,6	29,2	3,2	
	USFA210	115	94	190	157	76	40	18	54,6	22	15	10,9	-	43,5	-	-	M6x1	59,8	100	FA210	US210G2	-	SC0210-50	SCC210	35,1	23,2	2,2	
55	ESFA211	130	104	219	184	86	43	20	61,4	25	16	12	-	32,5	48,4	74,5	M6x1	77,8	110	FA211	ES211G2	-	SCOE211-55	SCCE211	43,6	29,2	2,9	55
	EXFA211	130	104	219	184	86	43	20	68,6	25	16	27,7	-	55,4	71,3	74,5	M6x1	77,8	110	FA211	EX211G2	-	SCOE211-55	SCCE211	43,6	29,2	3,4	
	UCFA211	130	104	219	184	86	43	20	58,4	25	16	22,2	-	55,6	-	-	M6x1	64,4	110	FA211	UC211G2	-	SC0211-55	SCC211	43,6	29,2	3,1	
	UKFA212H	140	118	250	202	92	48	20	60	29	23	-	31	36	62	80	M6x1	74,4	120	FA212	UK212G2H	H2312	SC0212-55	SCC212	52,5	32,8	4,2	
	USFA211	130	104	219	184	86	43	20	58,5	25	16	11,8	-	45,3	-	-	M6x1	64,4	110	FA211	US211G2	-	SC0211-55	SCC211	43,6	29,2	3,1	
60	ESFA212	140	118	250	202	92	48	20	66,3	29	23	12	-	33,4	49,3	82	M6x1	85	120	FA212	ES212G2	-	SCOE212-60	SCCE212	52,5	32,8	3,9	60
	EXFA212	140	118	250	202	92	48	20	75,8	29	23	30,9	-	61,8	77,7	82	M6x1	85	120	FA212	EX212G2	-	SCOE212-60	SCCE212	52,5	32,8	4,6	
	UCFA212	140	118	250	202	92	48	20	68,7	29	23	25,4	-	65,1	-	-	M6x1	74,4	120	FA212	UC212G2	-	SC0212-60	SCC212	52,5	32,8	4,2	
	USFA212	140	118	250	202	92	48	20	67,8	29	23	14,9	-	53,7	-	-	M6x1	74,4	120	FA212	US212G2	-	SC0212-60	SCC212	52,5	32,8	4,0	

* Bearing units that are ordered with cover(s) include the housings with grooves.
If you want to install the protective covers later, housings with suffix N must be ordered (for example: P210N).

CAST IRON HOUSINGS WITH CHROME STEEL BEARING INSERTS

FLANGED UNITS

Four-bolt flange with centering rim,
square design, heavy duty

FS3

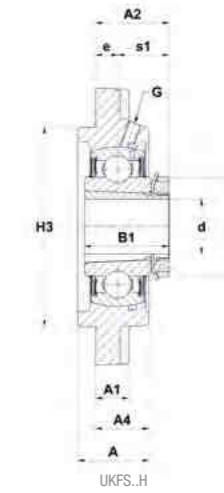
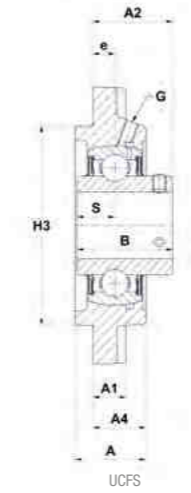
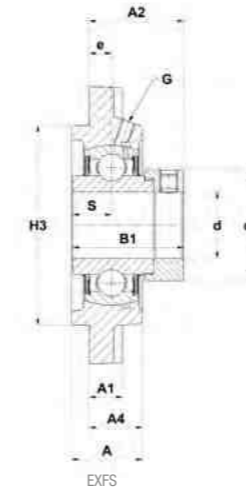
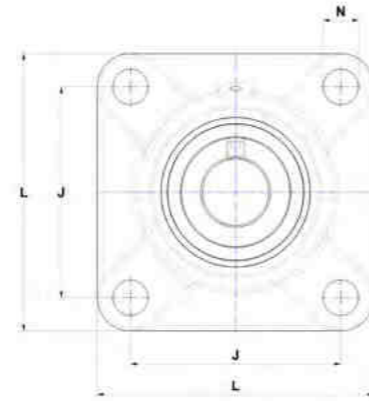

Main dimensions [mm]

d	Unit	L	J	A	A1	A2	A4	H3	e	N	S	s1	B	B1	d1	G	Housing	Bearing insert	Adapter sleeve	Dynamic load rating C [kN]	Static load rating C0 [kN]	Weight [kg]	d
20	UKFS305H	110	80	29	13	30,5	22	80	9	16	-	21,5	27	35	38	M6x1	FS305	UK305G2H	H2305	22,4	11,5	1,4	20
25	EXFS305	110	80	29	13	39,1	22	80	9	16	16,7	-	34,9	46,8	42,8	M6x1	FS305	EX305G2	-	22,4	11,5	1,3	25
	UCFS305	110	80	29	13	32	22	80	9	16	15	-	38	-	-	M6x1	FS305	UC305G2	-	22,4	11,5	1,3	25
	UKFS306H	125	95	32	15	33	24	90	10	16	-	23	30	38	45	M6x1	FS306	UK306G2H	H2306	27,0	15,2	1,9	25
30	EXFS306	125	95	32	15	42,5	24	90	10	16	17,5	-	36,5	50	50	M6x1	FS306	EX306G2	-	27,0	15,2	2,0	30
	UCFS306	125	95	32	15	36	24	90	10	16	17	-	43	-	-	M6x1	FS306	UC306G2	-	27,0	15,2	1,9	30
	UKFS307H	135	100	36	16	36,5	27	100	11	19	-	25,5	33	43	52	M6x1	FS307	UK307G2H	H2307	33,5	19,2	2,5	30
35	EXFS307	135	100	36	16	44,3	27	100	11	19	18,3	-	38,1	51,6	55	M6x1	FS307	EX307G2	-	33,5	19,2	2,4	35
	UCFS307	135	100	36	16	40	27	100	11	19	19	-	48	-	-	M6x1	FS307	UC307G2	-	33,5	19,2	2,3	35
	UKFS308H	150	112	40	17	40,5	30	115	13	19	-	27,5	35	46	58	M6x1	FS308	UK308G2H	H2308	40,6	24,0	3,1	35
40	EXFS308	150	112	40	17	50,3	30	115	13	19	19,8	-	41,3	57,1	63,5	M6x1	FS308	EX308G2	-	40,6	24,0	3,2	40
	UCFS308	150	112	40	17	46	30	115	13	19	19	-	52	-	-	M6x1	FS308	UC308G2	-	40,6	24,0	3,1	40
	UKFS309H	160	125	44	18	44	33	125	14	19	-	30	38	50	65	M6x1	FS309	UK309G2H	H2309	53,0	31,8	4,1	40
45	EXFS309	160	125	44	18	52,9	33	125	14	19	19,8	-	42,9	58,7	70	M6x1	FS309	EX309G2	-	53,0	31,8	4,1	45
	UCFS309	160	125	44	18	49	33	125	14	19	22	-	57	-	-	M6x1	FS309	UC309G2	-	53,0	31,8	3,9	45
	UKFS310H	175	132	48	19	48	36	140	16	23	-	32	40	55	70	M6x1	FS310	UK310G2H	H2310	62,0	37,8	4,9	45
50	EXFS310	175	132	48	19	58	36	140	16	23	24,6	-	49,2	66,6	76,2	M6x1	FS310	EX310G2	-	62,0	37,8	5,1	50
	UCFS310	175	132	48	19	55	36	140	16	23	22	-	61	-	-	M6x1	FS310	UC310G2	-	62,0	37,8	4,9	50
	UKFS311H	185	140	52	20	51	39	150	17	23	-	34	43	59	75	M6x1	FS311	UK311G2H	H2311	71,5	44,8	6,0	50
55	EXFS311	185	140	52	20	62,2	39	150	17	23	27,8	-	55,6	73	83	M6x1	FS311	EX311G2	-	71,5	44,8	6,1	55
	UCFS311	185	140	52	20	58	39	150	17	23	25	-	66	-	-	M6x1	FS311	UC311G2	-	71,5	44,8	5,7	55
	UKFS312H	195	150	56	22	55,5	42	160	19	23	-	36,5	47	62	80	M6x1	FS312	UK312G2H	H2312	81,6	51,8	7,4	55
60	EXFS312	195	150	56	22	67,4	42	160	19	23	31	-	61,9	79,4	89	M6x1	FS312	EX312G2	-	81,6	51,8	7,8	60
	UCFS312	195	150	56	22	64	42	160	19	23	26	-	71	-	-	M6x1	FS312	UC312G2	-	81,6	51,8	7,5	60
	UKFS313H	208	166	58	22	53,5	40	175	15	23	-	38,5	49	65	85	M6x1	FS313	UK313G2H	H2313	93,9	60,5	8,9	60
65	EXFS313	208	166	58	22	68,2	40	175	15	23	32,5	-	65,1	85,7	97	M6x1	FS313	EX313G2	-	93,9	60,5	9,3	65
	UCFS313	208	166	58	22	60	40	175	15	23	30	-	75	-	-	M6x1	FS313	UC313G2	-	93,9	60,5	8,9	65
	UKFS315H	236	184	66	25	63,5	48	200	21	25	-	42,5	55	73	98	M10x1	FS315	UK315G2H	H2315	113,4	76,8	13,1	65
70	EXFS314	226	178	61	25	75,9	43	185	18	25	34,2	-	68,3	92,1	102	M10x1	FS314	EX314G2	-	104,3	68,0	11,5	70
	UCFS314	226	178	61	25	63	43	185	18	25	33	-	78	-	-	M10x1	FS314	UC314G2	-	104,3	68,0	11,0	70
	UKFS316H	250	196	68	27	62,5	48	210	18	31	-	44,5	55	78	105	M10x1	FS316	UK316G2H	H2316	122,9	86,5	15,1	70
75	EXFS315	236	184	66	25	83,7	48	200	21	25	37,3	-	74,6	100	113	M10x1	FS315	EX315G2	-	113,4	76,8	13,4	75
	UCFS315	236	184	66	25	71	48	200	21	25	32	-	82	-	-	M10x1	FS315	UC315G2	-	113,4	76,8	12,4	75
	UKFS317H	260	204	74	27	72	54	220	24	31	-	48	60	82	110	M10x1	FS317	UK317G2H	H2317	132,6	96,5	17,4	75

CAST IRON HOUSINGS WITH CHROME STEEL BEARING INSERTS

FLANGED UNITS

Four-bolt flange with centering rim,
square design, heavy duty
FS3

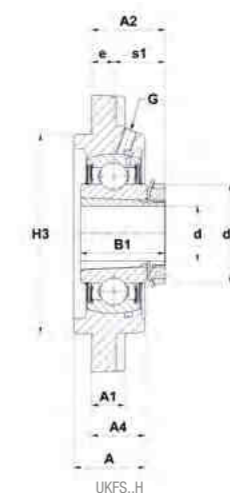
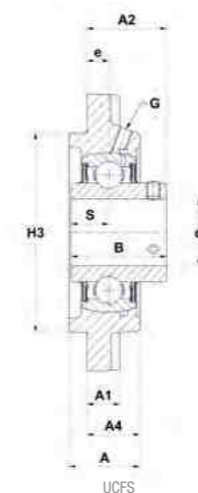
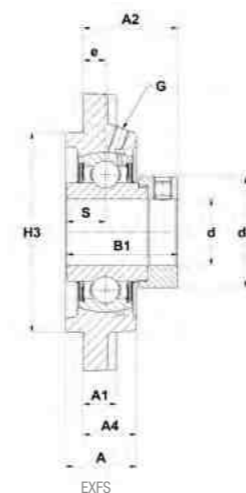
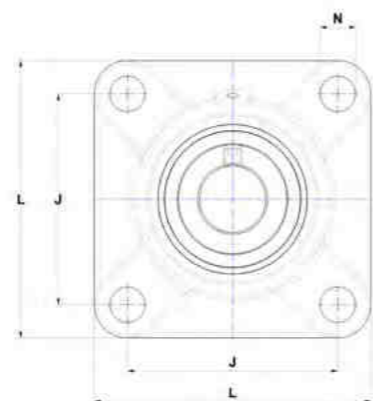

Main dimensions [mm]

d	Unit	L	J	A	A1	A2	A4	H3	e	N	S	s1	B	B1	d1	G	Housing	Bearing insert	Adapter sleeve	Dynamic load rating C [kN]	Static load rating C0 [kN]	Weight [kg]	d
80	EXFS316	250	196	68	27	83,9	48	210	18	31	40,5	-	81	106,4	119	M10x1	FS316	EX316G2	-	122,9	86,5	16,0	80
	UCFS316	250	196	68	27	70	48	210	18	31	34	-	86	-	-	M10x1	FS316	UC316G2	-	122,9	86,5	14,9	
	UKFS318H	280	216	76	30	72	56	240	24	35	-	48	60	86	120	M10x1	FS318	UK318G2H	H2318	143,0	108,0	21,3	
85	EXFS317	260	204	74	27	91,5	54	220	24	31	42	-	84,1	109,5	127	M10x1	FS317	EX317G2	-	132,6	96,5	18,5	85
	UCFS317	260	204	74	27	80	54	220	24	31	40	-	96	-	-	M10x1	FS317	UC317G2	-	132,6	96,5	17,3	
	UKFS319H	290	228	94	30	91	74	250	39	35	-	52	66	90	125	M10x1	FS319	UK319G2H	H2319	156,0	122,0	25,2	
90	EXFS318	280	216	76	30	96,3	56	240	24	35	43,6	-	87,3	115,9	133	M10x1	FS318	EX318G2	-	143,0	108,0	22,5	90
	UCFS318	280	216	76	30	80	56	240	24	35	40	-	96	-	-	M10x1	FS318	UC318G2	-	143,0	108,0	21,3	
	UKFS320H	310	242	94	32	93	74	260	39	38	-	54	68	97	130	M10x1	FS320	UK320G2H	H2320	171,6	140,0	29,2	
95	EXFS319	290	228	94	30	114,5	74	250	39	35	46,8	-	93,7	122,3	140	M10x1	FS319	EX319G2	-	156,0	122,0	26,4	95
	UCFS319	290	228	94	30	101	74	250	39	35	41	-	103	-	-	M10x1	FS319	UC319G2	-	156,0	122,0	24,9	
100	EXFS320	310	242	94	32	117,6	74	260	39	38	50	-	100	128,6	146	M10x1	FS320	EX320G2	-	171,6	140,0	31,2	100
	UCFS320	310	242	94	32	105	74	260	39	38	42	-	108	-	-	M10x1	FS320	UC320G2	-	171,6	140,0	29,4	
	UKFS322H	340	266	96	35	96	71	300	35	41	-	61	80	105	145	M10x1	FS322	UK322G2H	H2322	205,0	178,0	41,6	
105	UCFS321	310	242	94	32	107	74	260	39	38	44	-	112	-	-	M10x1	FS321	UC321G2	-	182,0	155,0	29,8	105
110	UCFS322	340	266	96	35	106	71	300	35	41	46	-	117	-	-	M10x1	FS322	UC322G2	-	205,0	178,0	38,3	110
	UKFS324H	370	290	110	40	100,5	80	330	35	41	-	65,5	87	112	155	M10x1	FS324	UK324G2H	H2324	228,0	208,0	54,4	
115	UKFS326H	410	320	115	45	103	85	360	35	41	-	68	90	121	165	M10x1	FS326	UK326G2H	H2326	252,0	242,0	72,8	115
120	UCFS324	370	290	110	40	110	80	330	35	41	51	-	126	-	-	M10x1	FS324	UC324G2	-	228,0	208,0	51,7	120
125	UKFS328H	450	350	125	55	118	95	400	45	41	-	73	98	131	180	M10x1	FS328	UK328G2H	H2328	275,0	272,0	98,7	125
130	UCFS326	410	320	115	45	116	85	360	35	41	54	-	135	-	-	M10x1	FS326	UC326G2	-	252,0	242,0	67,9	130
140	UCFS328	450	350	125	55	131	95	400	45	41	59	-	145	-	-	M10x1	FS328	UC328G2	-	275,0	272,0	92,7	140

CAST IRON HOUSINGS WITH CHROME STEEL BEARING INSERTS

TENSIONER- / HANG UP- / CARTRIDGE UNITS

Take-up unit
T2

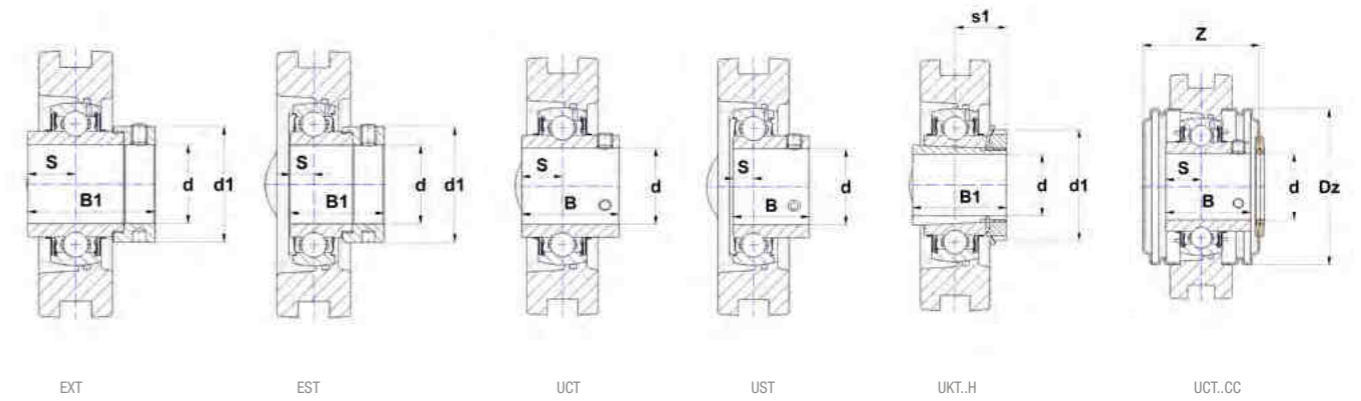
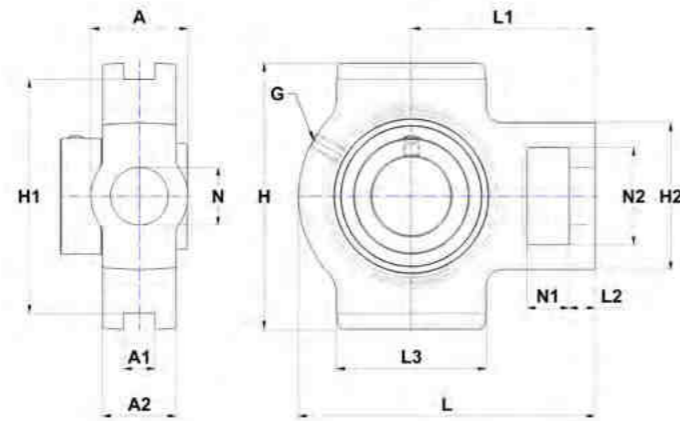

Main dimensions [mm]

d	Unit	L	L1	L2	L3	A	A1	A2	H	H1	H2	N	N1	N2	S	s1	B	B1	d1	G	Z	Dz	Housing	Bearing insert	Adapter sleeve	Open protective cap*	Closed protective cap*	Dynamic load rating C [kN]	Static load rating C0 [kN]	Weight [kg]	d
12	EXT201	94	61	10	51	32	12	21	89	76	51	19 mm	16	32	17	-	34	43,5	32,4	M6x1	62,7	54	T204	EX201G2	-	SCOE204-12	SCCE204	12,8	6,7	0,9	12
	UCT201	94	61	10	51	32	12	21	89	76	51	19 mm	16	32	12,7	-	31	-	-	M6x1	44,3	54	T204	UC201G2	-	SCO204-12	SCC204	12,8	6,7	0,8	
15	EXT202	94	61	10	51	32	12	21	89	76	51	19 mm	16	32	17	-	34	43,5	32,4	M6x1	62,7	54	T204	EX202G2	-	SCOE204-15	SCCE204	12,8	6,7	0,9	15
	UCT202	94	61	10	51	32	12	21	89	76	51	19 mm	16	32	12,7	-	31	-	-	M6x1	44,3	54	T204	UC202G2	-	SCO204-15	SCC204	12,8	6,7	0,8	
17	EXT203	94	61	10	51	32	12	21	89	76	51	19 mm	16	32	17	-	34	43,5	32,4	M6x1	62,7	54	T204	EX203G2	-	SCOE204-17	SCCE204	12,8	6,7	0,9	17
	UCT203	94	61	10	51	32	12	21	89	76	51	19 mm	16	32	12,7	-	31	-	-	M6x1	44,3	54	T204	UC203G2	-	SCO204-17	SCC204	12,8	6,7	0,8	
20	EST204	94	61	10	51	32	12	21	89	76	51	19 mm	16	32	7,5	-	21,4	30,9	32,4	M6x1	62,7	54	T204	ES204G2	-	SCOE204-20	SCCE204	12,8	6,7	0,8	20
	EXT204	94	61	10	51	32	12	21	89	76	51	19 mm	16	32	17	-	34	43,5	32,4	M6x1	62,7	54	T204	EX204G2	-	SCOE204-20	SCCE204	12,8	6,7	0,8	
	UCT204	94	61	10	51	32	12	21	89	76	51	19 mm	16	32	12,7	-	31	-	-	M6x1	44,3	54	T204	UC204G2	-	SCO204-20	SCC204	12,8	6,7	0,8	
	UKT205H	97	62	10	51	32	12	24	89	76	51	19 mm	16	32	-	18,5	21	35	38	M6x1	47,5	60	T205	UK205G2H	H2305	SCO205-20	SCC205	14,0	7,9	0,8	
	UST204	94	61	10	51	32	12	21	89	76	51	19 mm	16	32	7	-	25	-	-	M6x1	44,3	54	T204	US204G2	-	SCO204-20	SCC204	12,8	6,7	0,7	
25	EST205	97	62	10	51	32	12	24	89	76	51	19 mm	16	32	7,5	-	21,4	30,9	37,4	M6x1	64,7	60	T205	ES205G2	-	SCOE205-25	SCCE205	14,0	7,9	0,8	25
	EXT205	97	62	10	51	32	12	24	89	76	51	19 mm	16	32	17,4	-	34,8	44,3	37,4	M6x1	64,7	60	T205	EX205G2	-	SCOE205-25	SCCE205	14,0	7,9	0,9	
	UCT205	97	62	10	51	32	12	24	89	76	51	19 mm	16	32	14,3	-	34	-	-	M6x1	47,5	60	T205	UC205G2	-	SCO205-25	SCC205	14,0	7,9	0,8	
	UKT206H	113	70	10	57	37	12	28	102	89	56	22 mm	16	37	-	20,5	25	38	45	M6x1	52,5	70	T206	UK206G2H	H2306	SCO206-25	SCC206	19,5	11,2	1,3	
	UST205	97	62	10	51	32	12	24	89	76	51	19 mm	16	32	7,5	-	27	-	-	M6x1	47,5	60	T205	US205G2	-	SCO205-25	SCC205	14,0	7,9	0,8	
30	EST206	113	70	10	57	37	12	28	102	89	56	22 mm	16	37	9	-	23,8	35,7	44,1	M6x1	70,7	70	T206	ES206G2	-	SCOE206-30	SCCE206	19,5	11,2	1,2	30
	EXT206	113	70	10	57	37	12	28	102	89	56	22 mm	16	37	18,2	-	36,4	48,3	44,1	M6x1	70,7	70	T206	EX206G2	-	SCOE206-30	SCCE206	19,5	11,2	1,3	
	UCT206	113	70	10	57	37	12	28	102	89	56	22 mm	16	37	15,9	-	38,1	-	-	M6x1	52,5	70	T206	UC206G2	-	SCO206-30	SCC206	19,5	11,2	1,2	
	UKT207H	129	78	13	64	37	12	30	102	89	64	22 mm	16	37	-	22,5	27	43	52	M6x1	59,1	80	T207	UK207G2H	H2307	SCO207-30	SCC207	25,7	15,2	1,6	
	UST206	113	70	10	57	37	12	28	102	89	56	22 mm	16	37	8	-	30	-	-	M6x1	52,5	70	T206	US206G2	-	SCO206-30	SCC206	19,5	11,2	1,2	
35	EST207	129	78	13	64	37	12	30	102	89	64	22 mm	16	37	9,5	-	25,4	38,9	51,1	M6x1	77,7	80	T207	ES207G2	-	SCOE207-35	SCCE207	25,7	15,2	1,6	35
	EXT207	129	78	13	64	37	12	30	102	89	64	22 mm	16	37	18,8	-	37,6	51,1	51,1	M6x1	77,7	80	T207	EX207G2	-	SCOE207-35	SCCE207	25,7	15,2	1,7	
	UCT207	129	78	13	64	37	12	30	102	89	64	22 mm	16	37	17,5	-	42,9	-	-	M6x1	59,1	80	T207	UC207G2	-	SCO207-30	SCC207	25,7	15,2	1,6	
	UKT208H	144	88	16	83	49	16	33	114	102	83	29 mm	19	49	-	24,5	29	46	58	M6x1	68,6	88	T208	UK208G2H	H2308	SCO208-35	SCC208	29,6	18,2	2,4	
	UST207	129	78	13	64	37	12	30	102	89	64	22 mm	16	37	8,5	-	32	-	-	M6x1	59,1	80	T207	US207G2	-	SCO207-30	SCC207	25,7	15,2	1,5	
40	EST208	144	88	16	83	49	16	33	114	102	83	29 mm	19	49	11	-	30,2	43,7	58	M6x1	80,8	88	T208	ES208G2	-	SCOE208-40	SCCE208	29,6	18,2	2,4	40
	EXT208	144	88	16	83	49	16	33	114	102	83	29 mm	19	49	21,4	-	42,8	56,3	58	M6x1	80,8	88	T208	EX208G2	-	SCOE208-40	SCCE208	29,6	18,2	2,5	
	UCT208	144	88	16	83	49	16	33	114	102	83	29 mm	19	49	19	-	49,2	-	-	M6x1	68,6	88	T208	UC208G2	-	SCO208-40	SCC208	29,6	18,2	2,3	
	UKT209H	144	87	16	83	49	16	35	117	102	83	29 mm	19	49	-	26	30	50	65	M6x1	70,2	95	T209	UK209G2H	H2309	SCO209-40	SCC209	31,9	20,8	2,5	
	UST208	144	88	16	83	49	16	33	114	102	83	29 mm	19	49	9	-	34	-	-	M6x1	68,6	88	T208	US208G2	-	SCO208-40	SCC208	29,6	18,2	2,3	

* Bearing units that are ordered with cover(s) include the housings with grooves.
If you want to install the protective covers later, housings with suffix N must be ordered (for example: P210N).

CAST IRON HOUSINGS WITH CHROME STEEL BEARING INSERTS

TENSIONER- / HANG UP- / CARTRIDGE UNITS

Take-up unit, heavy duty

T3

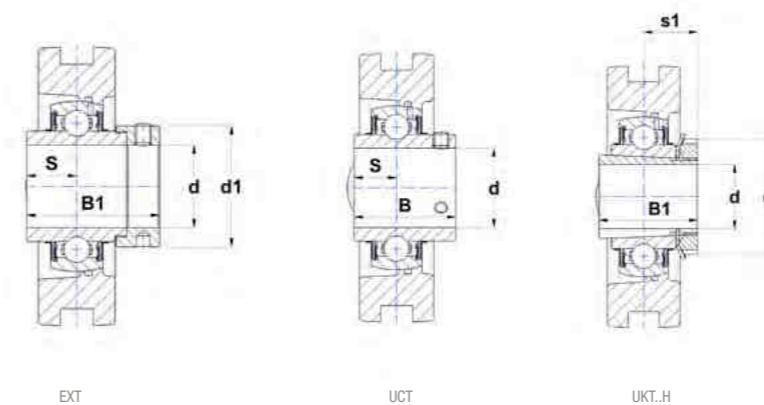
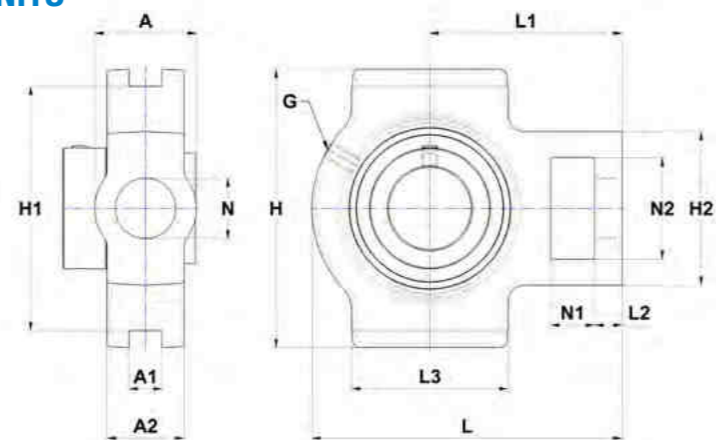

Main dimensions [mm]

d	Unit	L	L1	L2	L3	A	A1	A2	H	H1	H2	N	N1	N2	S	s1	B	B1	d1	G	Housing	Bearing insert	Adapter sleeve	Dynamic load rating C [kN]	Static load rating C0 [kN]	Weight [kg]	d
20	UKT305H	122	76	14	65	36	12	26	89	80	62	26	16	36	-	21,5	27	35	38	M6x1	T305	UK305G2H	H2305	22,4	11,5	1,4	20
25	EXT305	122	76	14	65	36	12	26	89	80	62	26	16	36	16,7	-	34,9	46,8	42,8	M6x1	T305	EX305G2	-	22,4	11,5	1,3	25
	UCT305	122	76	14	65	36	12	26	89	80	62	26	16	36	15	-	38	-	-	M6x1	T305	UC305G2	-	22,4	11,5	1,3	
	UKT306H	137	85	16	74	41	16	28	100	90	70	28	18	41	-	23	30	38	45	M6x1	T306	UK306G2H	H2306	27,0	15,2	1,8	
30	EXT306	137	85	16	74	41	16	28	100	90	70	28	18	41	17,5	-	36,5	50	50	M6x1	T306	EX306G2	-	27,0	15,2	1,9	30
	UCT306	137	85	16	74	41	16	28	100	90	70	28	18	41	17	-	43	-	-	M6x1	T306	UC306G2	-	27,0	15,2	1,8	
	UKT307H	150	94	17	80	45	16	32	111	100	75	30	20	45	-	25,5	33	43	52	M6x1	T307	UK307G2H	H2307	33,5	19,2	2,5	
35	EXT307	150	94	17	80	45	16	32	111	100	75	30	20	45	18,3	-	38,1	51,6	55	M6x1	T307	EX307G2	-	33,5	19,2	2,4	35
	UCT307	150	94	17	80	45	16	32	111	100	75	30	20	45	19	-	48	-	-	M6x1	T307	UC307G2	-	33,5	19,2	2,3	
	UKT308H	162	100	19	89	50	18	34	124	112	83	32	22	50	-	27,5	35	46	58	M6x1	T308	UK308G2H	H2308	40,6	24,0	3,0	
40	EXT308	162	100	19	89	50	18	34	124	112	83	32	22	50	19,8	-	41,3	57,1	63,5	M6x1	T308	EX308G2	-	40,6	24,0	3,1	40
	UCT308	162	100	19	89	50	18	34	124	112	83	32	22	50	19	-	52	-	-	M6x1	T308	UC308G2	-	40,6	24,0	3,0	
	UKT309H	178	110	20	97	55	18	38	138	125	90	34	24	55	-	30	38	50	65	M6x1	T309	UK309G2H	H2309	53,0	31,8	4,2	
45	EXT309	178	110	20	97	55	18	38	138	125	90	34	24	55	19,8	-	42,9	58,7	70	M6x1	T309	EX309G2	-	53,0	31,8	4,2	45
	UCT309	178	110	20	97	55	18	38	138	125	90	34	24	55	22	-	57	-	-	M6x1	T309	UC309G2	-	53,0	31,8	4,0	
	UKT310H	192	118	22	106	61	20	40	151	140	98	37	27	61	-	32	40	55	70	M6x1	T310	UK310G2H	H2310	62,0	37,8	5,1	
50	EXT310	192	118	22	106	61	20	40	151	140	98	37	27	61	24,6	-	49,2	66,6	76,2	M6x1	T310	EX310G2	-	62,0	37,8	5,3	50
	UCT310	192	118	22	106	61	20	40	151	140	98	37	27	61	22	-	61	-	-	M6x1	T310	UC310G2	-	62,0	37,8	5,1	
	UKT311H	207	127	23	115	66	22	44	163	150	105	39	29	66	-	34	43	59	75	M6x1	T311	UK311G2H	H2311	71,5	44,8	6,4	
55	EXT311	207	127	23	115	66	22	44	163	150	105	39	29	66	27,8	-	55,6	73	83	M6x1	T311	EX311G2	-	71,5	44,8	6,5	55
	UCT311	207	127	23	115	66	22	44	163	150	105	39	29	66	25	-	66	-	-	M6x1	T311	UC311G2	-	71,5	44,8	6,1	
	UKT312H	220	135	25	123	71	22	46	178	160	113	41	31	71	-	36,5	47	62	80	M6x1	T312	UK312G2H	H2312	81,6	51,8	7,5	
60	EXT312	220	135	25	123	71	22	46	178	160	113	41	31	71	31	-	61,9	79,4	89	M6x1	T312	EX312G2	-	81,6	51,8	7,9	60
	UCT312	220	135	25	123	71	22	46	178	160	113	41	31	71	26	-	71	-	-	M6x1	T312	UC312G2	-	81,6	51,8	7,6	
	UKT313H	238	146	27	134	80	26	50	190	170	116	43	32	70	-	38,5	49	65	85	M6x1	T313	UK313G2H	H2313	93,9	60,5	9,5	
65	EXT313	238	146	27	134	80	26	50	190	170	116	43	32	70	32,5	-	65,1	85,7	97	M6x1	T313	EX313G2	-	93,9	60,5	9,9	65
	UCT313	238	146	27	134	80	26	50	190	170	116	43	32	70	30	-	75	-	-	M6x1	T313	UC313G2	-	93,9	60,5	9,5	
	UKT315H	262	160	27	150	90	26	55	216	192	132	46	36	85	-	42,5	55	73	98	M10x1	T315	UK315G2H	H2315	113,4	76,8	13,2	
70	EXT314	252	155	27	140	90	26	52	202	180	130	46	36	85	34,2	-	68,3	92,1	102	M10x1	T314	EX314G2	-	104,3	68,0	11,7	70
	UCT314	252	155	27	140	90	26	52	202	180	130	46	36	85	33	-	78	-	-	M10x1	T314	UC314G2	-	104,3	68,0	11,2	
	UKT316H	282	174	30	160	102	30	60	230	204	150	53	42	98	-	44,5	55	78	105	M10x1	T316	UK316G2H	H2316	122,9	86,5	16,2	

CAST IRON HOUSINGS WITH CHROME STEEL BEARING INSERTS

TENSIONER- / HANG UP- / CARTRIDGE UNITS

Take-up unit, heavy duty

T3

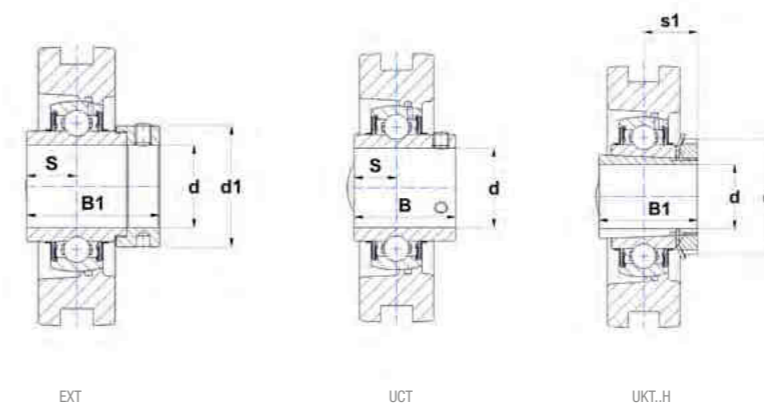
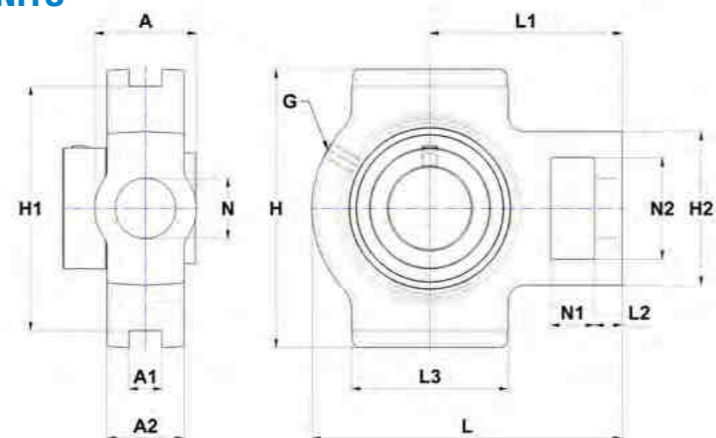

Main dimensions [mm]

d	Unit	L	L1	L2	L3	A	A1	A2	H	H1	H2	N	N1	N2	S	s1	B	B1	d1	G	Housing	Bearing insert	Adapter sleeve	Dynamic load rating C [kN]	Static load rating C0 [kN]	Weight [kg]	d
75	EXT315	262	160	27	150	90	26	55	216	192	132	46	36	85	37,3	-	74,6	100	113	M10x1	T315	EX315G2	-	113,4	76,8	13,5	75
	UCT315	262	160	27	150	90	26	55	216	192	132	46	36	85	32	-	82	-	-	M10x1	T315	UC315G2	-	113,4	76,8	12,5	
	UKT317H	298	183	32	170	102	32	64	240	214	152	53	42	98	-	48	60	82	110	M10x1	T317	UK317G2H	H2317	132,6	96,5	19,0	
80	EXT316	282	174	30	160	102	30	60	230	204	150	53	42	98	40,5	-	81	106,4	119	M10x1	T316	EX316G2	-	122,9	86,5	17,1	80
	UCT316	282	174	30	160	102	30	60	230	204	150	53	42	98	34	-	86	-	-	M10x1	T316	UC316G2	-	122,9	86,5	16,0	
	UKT318H	312	192	32	175	110	32	66	255	228	160	57	46	106	-	48	60	86	120	M10x1	T318	UK318G2H	H2318	143,0	108,0	21,5	
85	EXT317	298	183	32	170	102	32	64	240	214	152	53	42	98	42	-	84,1	109,5	127	M10x1	T317	EX317G2	-	132,6	96,5	20,1	85
	UCT317	298	183	32	170	102	32	64	240	214	152	53	42	98	40	-	96	-	-	M10x1	T317	UC317G2	-	132,6	96,5	18,9	
	UKT319H	322	197	33	180	110	35	72	270	240	165	57	46	106	-	52	66	90	125	M10x1	T319	UK319G2H	H2319	156,0	122,0	24,9	
90	EXT318	312	192	32	175	110	32	66	255	228	160	57	46	106	43,6	-	87,3	115,9	133	M10x1	T318	EX318G2	-	143,0	108,0	22,7	90
	UCT318	312	192	32	175	110	32	66	255	228	160	57	46	106	40	-	96	-	-	M10x1	T318	UC318G2	-	143,0	108,0	21,5	
	UKT320H	345	210	34	200	120	35	75	290	260	175	59	48	115	-	54	68	97	130	M10x1	T320	UK320G2H	H2320	171,6	140,0	30,4	
95	EXT319	322	197	33	180	110	35	72	270	240	165	57	46	106	46,8	-	93,7	122,3	140	M10x1	T319	EX319G2	-	156,0	122,0	26,1	95
	UCT319	322	197	33	180	110	35	72	270	240	165	57	46	106	41	-	103	-	-	M10x1	T319	UC319G2	-	156,0	122,0	24,6	
100	EXT320	345	210	34	200	120	35	75	290	260	175	59	48	115	50	-	100	128,6	146	M10x1	T320	EX320G2	-	171,6	140,0	32,4	100
	UCT320	345	210	34	200	120	35	75	290	260	175	59	48	115	42	-	108	-	-	M10x1	T320	UC320G2	-	171,6	140,0	30,6	
	UKT322H	385	235	40	215	130	38	80	320	285	185	65	52	125	-	61	80	105	145	M10x1	T322	UK322G2H	H2322	205,0	178,0	41,9	
105	UCT321	347	212	34	200	120	35	75	290	260	175	59	48	115	44	-	112	-	-	M10x1	T321	UC321G2	-	182,0	155,0	30,0	105
110	UCT322	385	235	40	215	130	38	80	320	285	185	65	52	125	46	-	117	-	-	M10x1	T322	UC322G2	-	205,0	178,0	38,6	110
	UKT324H	432	267	44	230	140	45	90	355	320	210	70	60	140	-	65,5	87	112	155	M10x1	T324	UK324G2H	H2324	228,0	208,0	56,6	
115	UKT326H	465	285	47	240	150	50	100	385	350	220	75	65	150	-	68	90	121	165	M10x1	T326	UK326G2H	H2326	252,0	242,0	72,7	115
120	UCT324	432	267	44	230	140	45	90	355	320	210	70	60	140	51	-	126	-	-	M10x1	T324	UC324G2	-	228,0	208,0	53,9	120
125	UKT328H	515	315	52	255	155	50	100	415	380	230	80	70	160	-	73	98	131	180	M10x1	T328	UK328G2H	H2328	275,0	272,0	89,2	125
130	UCT326	465	285	47	240	150	50	100	385	350	220	75	65	150	54	-	135	-	-	M10x1	T326	UC326G2	-	252,0	242,0	67,8	130
140	UCT328	515	315	52	255	155	50	100	415	380	230	80	70	160	59	-	145	-	-	M10x1	T328	UC328G2	-	275,0	272,0	83,2	140

CAST IRON HOUSINGS WITH CHROME STEEL BEARING INSERTS

TENSIONER- / HANG UP- / CARTRIDGE UNITS

Take-up unit with frame
T2 + WB

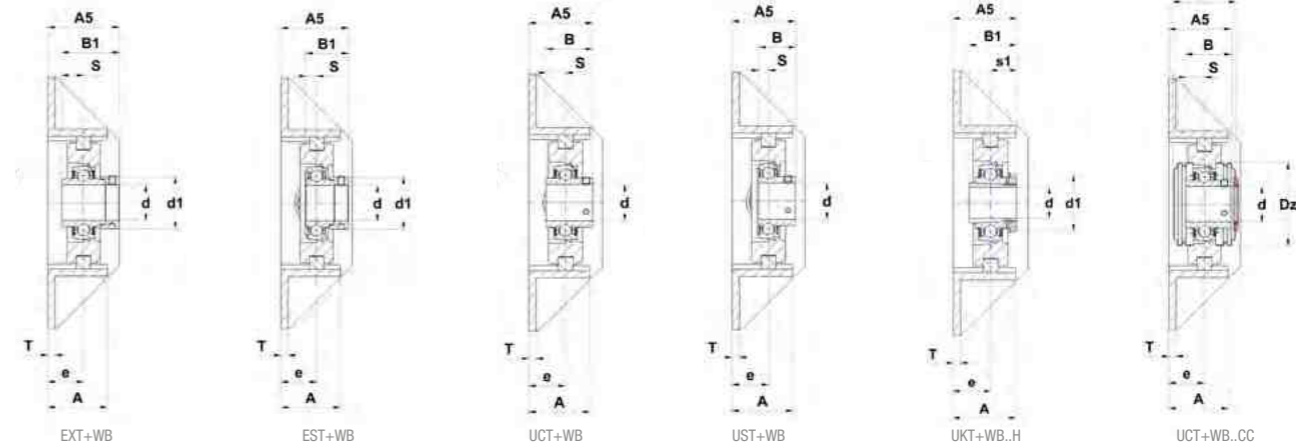
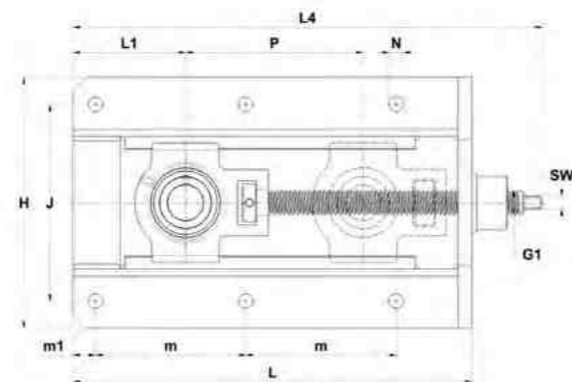

Main dimensions [mm]

d	Unit	L	H	J	m	m1	N	A	A5	L4	L1	P	T	e	G1	SW	s	s1	B	B1	d1	Z	Dz	Housing	Bearing insert	Adapter sleeve	Stretcher frame	Open protective cap*	Closed protective cap*	Dynamic load rating C [kN]	Static load rating C0 [kN]	Weight [kg]	d
45	EST209+WB	520	233	192	219	22	15	50	62,7	593	108	300	6	30	Tr 24x5	15	11	-	-	43,7	63,5	84,4	95	T209	ES209G2	-	WB210	SCOE209-45	SCCE209	31,9	20,8	10,2	45
	EXT209+WB	520	233	192	219	22	15	50	64,9	593	108	300	6	30	Tr 24x5	15	21,4	-	-	56,3	62	84,4	95	T209	EX209G2	-	WB210	SCOE209-45	SCCE209	31,9	20,8	10,4	
	UCT209+WB	520	233	192	219	22	15	50	60,2	593	108	300	6	30	Tr 24x5	15	19	-	49,2	-	-	70,2	95	T209	UC209G2	-	WB210	SCOE209-45	SCC209	31,9	20,8	10,2	
	UKT210H+WB	520	233	192	219	22	15	50	57,5	593	108	300	6	30	Tr 24x5	15	-	27,5	-	55	70	74,6	100	T210	UK210G2H	H2310	WB210	SCOE210-45	SCC210	35,1	23,2	10,5	
	UST209+WB	520	233	192	219	22	15	50	61	593	108	300	6	30	Tr 24x5	15	10,2	-	41,2	-	-	70,2	95	T209	US209G2	-	WB210	SCOE209-45	SCC209	31,9	20,8	10,2	
50	EST210+WB	520	233	192	219	22	15	50	62,7	593	108	300	6	30	Tr 24x5	15	11	-	-	43,7	67,2	90	100	T210	ES210G2	-	WB210	SCOE210-50	SCCE210	35,1	23,2	10,3	50
	EXT210+WB	520	233	192	219	22	15	50	68,1	593	108	300	6	30	Tr 24x5	15	24,6	-	-	62,7	67,2	90	100	T210	EX210G2	-	WB210	SCOE210-50	SCCE210	35,1	23,2	10,5	
	UCT210+WB	520	233	192	219	22	15	50	62,6	593	108	300	6	30	Tr 24x5	15	19	-	51,6	-	-	74,6	100	T210	UC210G2	-	WB210	SCOE210-50	SCC210	35,1	23,2	10,3	
	UKT211H+WB	542	301	240	230	22	15	65	67	631	114	300	6	38	Tr 30x6	19	-	29	-	59	75	76,8	110	T211	UK211G2H	H2311	WB211	SCOE211-50	SCC211	43,6	29,2	16,6	
	UST210+WB	520	233	192	219	22	15	50	62,6	593	108	300	6	30	Tr 24x5	15	10,9	-	43,5	-	-	74,6	100	T210	US210G2	-	WB210	SCOE210-50	SCC210	35,1	23,2	10,3	
55	EST211+WB	542	301	240	230	22	15	65	74,4	631	114	300	6	38	Tr 30x6	19	12	-	-	48,4	74,5	103,6	110	T211	ES211G2	-	WB211	SCOE211-55	SCCE211	43,6	29,2	16,3	55
	EXT211+WB	542	301	240	230	22	15	65	81,6	631	114	300	6	38	Tr 30x6	19	27,7	-	-	71,3	74,5	103,6	110	T211	EX211G2	-	WB211	SCOE211-55	SCCE211	43,6	29,2	16,8	
	UCT211+WB	542	301	240	230	22	15	65	71,4	631	114	300	6	38	Tr 30x6	19	22,2	-	55,6	-	-	76,8	110	T211	UC211G2	-	WB211	SCOE211-55	SCC211	43,6	29,2	16,5	
	UKT212H+WB	568	301	240	243	22	15	65	69	651	127	300	6	38	Tr 30x6	19	-	31	-	62	80	90	120	T212	UK212G2H	H2312	WB212	SCOE212-55	SCC212	52,5	32,8	17,8	
	UST211+WB	542	301	240	230	22	15	65	71,5	631	114	300	6	38	Tr 30x6	19	11,8	-	45,3	-	-	76,8	110	T211	US211G2	-	WB211	SCOE211-55	SCC211	43,6	29,2	16,5	
60	EST212+WB	568	301	240	243	22	15	65	75,3	651	127	300	6	38	Tr 30x6	19	12	-	-	49,3	82	111,2	120	T212	ES212G2	-	WB212	SCOE212-60	SCCE212	52,5	32,8	17,5	60
	EXT212+WB	568	301	240	243	22	15	65	84,8	651	127	300	6	38	Tr 30x6	19	30,9	-	-	77,7	82	111,2	120	T212	EX212G2	-	WB212	SCOE212-60	SCCE212	52,5	32,8	18,2	
	UCT212+WB	568	301	240	243	22	15	65	77,7	651	127	300	6	38	Tr 30x6	19	25,4	-	65,1	-	-	90	120	T212	UC212G2	-	WB212	SCOE212-60	SCC212	52,5	32,8	17,8	
	UKT213H+WB	606	322	260	260	22	15	65	70	699	144	300	6	38	Tr 30x6	24	-	32	-	65	85	90,6	132	T213	UK213G2H	H2313	WB213	SCOE213-60	SCC213	57,2	40,0	21,5	
	UST212+WB	568	301	240	243	22	15	65	76,8	651	127	300	6	38	Tr 30x6	19	14,9	-	53,7	-	-	90	120	T212	US212G2	-	WB212	SCOE212-60	SCC212	52,5	32,8	17,6	
65	EXT213+WB	606	322	260	260	22	15	65	89,6	699	144	300	6	38	Tr 30x6	24	34,1	-	-	85,7	86	119,8	132	T213	EX213G2	-	WB213	SCOE213-65	SCCE213	57,2	40,0	22,0	65
	UCT213+WB	606	322	260	260	22	15	65	77,7	699	144	300	6	38	Tr 30x6	24	25,4	-	65,1	-	-	90,6	132	T213	UC213G2	-	WB213	SCOE213-65	SCC213	57,2	40,0	21,5	

* Bearing units that are ordered with cover(s) include the housings with grooves.
If you want to install the protective covers later, housings with suffix N must be ordered (for example: P210N).

G1: Trapezoidal screw thread

CAST IRON HOUSINGS WITH CHROME STEEL BEARING INSERTS

TENSIONER- / HANG UP- / CARTRIDGE UNITS

Tensioner unit
SP2

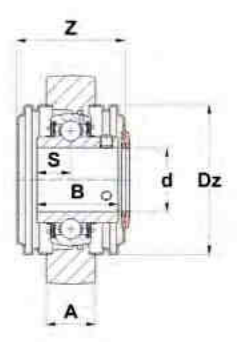
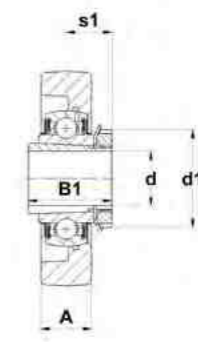
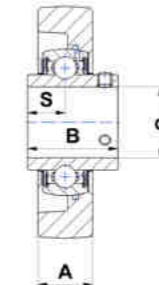
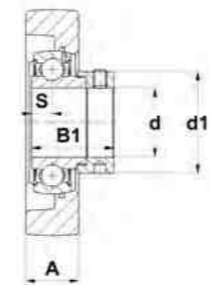
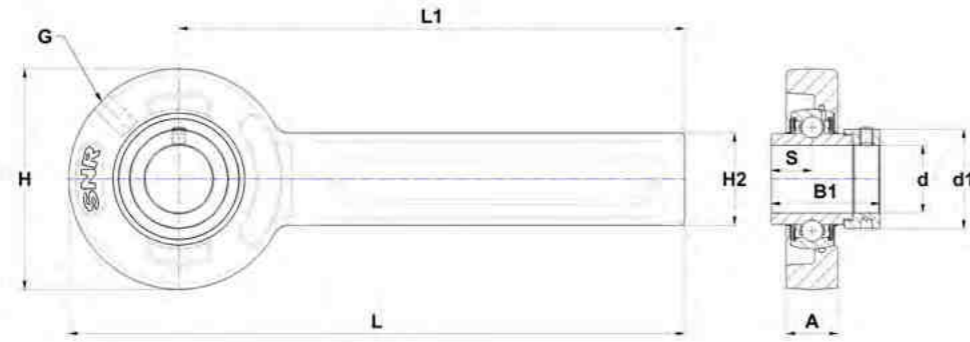

Main dimensions [mm]

d	Unit	L	L1	H	H2	A	S	s1	B	B1	d1	G	Z	Dz	Housing	Bearing insert	Adapter sleeve	Stretcher frame **	Open protective cap *1	Closed protective cap *1	Dynamic load rating C [kN]	Static load rating C0 [kN]	Weight [kg]	d
12	ESSP201	264	225	78	41	21	6,5	-	19	28,6	27,2	R1/8"	55,5	46	SP203-205/40	ES201G2	-	SPR1 SPR11 SPR12 SPR14	SCCE203	SCOE201-12	9,6	4,8	1,6	12
	EXSP201	264	225	78	41	21	17	-	34	43,5	32,4	R1/8"	64	54	SP203-205/47	EX201G2	-	SPR1 SPR11 SPR12 SPR14	SCCE204	SCOE204-12	12,8	6,7	1,7	
	UCSP201	264	225	78	41	21	12,7	-	31	-	-	R1/8"	45,6	54	SP203-205/47	UC201G2	-	SPR1 SPR11 SPR12 SPR14	SCC204	SCO204-12	12,8	6,7	1,6	
	USSP201	264	225	78	41	21	6	-	22	-	-	R1/8"	42,1	46	SP203-205/40	US201G2	-	SPR1 SPR11 SPR12 SPR14	SCC203	SCO201-12	9,6	4,8	1,6	
15	ESSP202	264	225	78	41	21	6,5	-	19,1	28,6	27,2	R1/8"	55,5	46	SP203-205/40	ES202G2	-	SPR1 SPR11 SPR12 SPR14	SCCE203	SCOE202-15	9,6	4,8	1,6	15
	EXSP202	264	225	78	41	21	17	-	34	43,5	32,4	R1/8"	64	54	SP203-205/47	EX202G2	-	SPR1 SPR11 SPR12 SPR14	SCCE204	SCOE204-15	12,8	6,7	1,7	
	UCSP202	264	225	78	41	21	12,7	-	31	-	-	R1/8"	45,6	54	SP203-205/47	UC202G2	-	SPR1 SPR11 SPR12 SPR14	SCC204	SCO204-15	12,8	6,7	1,6	
	USSP202	264	225	78	41	21	6	-	22	-	-	R1/8"	42,1	46	SP203-205/40	US202G2	-	SPR1 SPR11 SPR12 SPR14	SCC203	SCO202-15	9,6	4,8	1,6	
17	ESSP203	264	225	78	41	21	6,5	-	19,1	28,6	27,2	R1/8"	55,5	46	SP203-205/40	ES203G2	-	SPR1 SPR11 SPR12 SPR14	SCCE203	SCOE203-17	9,6	4,8	1,6	17
	EXSP203	264	225	78	41	21	17	-	34	43,5	32,4	R1/8"	64	54	SP203-205/47	EX203G2	-	SPR1 SPR11 SPR12 SPR14	SCCE204	SCOE204-20	12,8	6,7	1,7	
	UCSP203	264	225	78	41	21	12,7	-	31	-	-	R1/8"	45,6	54	SP203-205/47	UC203G2	-	SPR1 SPR11 SPR12 SPR14	SCC204	SCO204-17	12,8	6,7	1,6	
	USSP203	264	225	78	41	21	6	-	22	-	-	R1/8"	42,1	46	SP203-205/40	US203G2	-	SPR1 SPR11 SPR12 SPR14	SCC203	SCO203-17	9,6	4,8	1,6	
20	ESSP204	264	225	78	41	21	7,5	-	21,4	30,9	32,4	R1/8"	64	54	SP203-205/47	ES204G2	-	SPR1 SPR11 SPR12 SPR14	SCCE204	SCOE204-20	12,8	6,7	1,6	20
	EXSP204	264	225	78	41	21	17	-	34	43,5	32,4	R1/8"	64	54	SP203-205/47	EX204G2	-	SPR1 SPR11 SPR12 SPR14	SCCE204	SCOE204-20	12,8	6,7	1,6	
	UCSP204	264	225	78	41	21	12,7	-	31	-	-	R1/8"	45,6	54	SP203-205/47	UC204G2	-	SPR1 SPR11 SPR12 SPR14	SCC204	SCO204-20	12,8	6,7	1,6	
	UKSP205H	264	225	78	41	21	-	18,5	21	35	38	R1/8"	47,8	60	SP203-205/52	UK205G2H	H2305	SPR1 SPR11 SPR12 SPR14	SCC205	SCO205-20	14,0	7,9	1,6	
	USSP204	264	225	78	41	21	7	-	25	-	-	R1/8"	45,6	54	SP203-205/47	US204G2	-	SPR1 SPR11 SPR12 SPR14	SCC204	SCO204-20	12,8	6,7	1,5	
25	ESSP205	264	225	78	41	21	7,5	-	21,4	30,9	37,4	R1/8"	65	60	SP203-205/52	ES205G2	-	SPR1 SPR11 SPR12 SPR14	SCCE205	SCOE205-25	14,0	7,9	1,6	25
	EXSP205	264	225	78	41	21	17,4	-	34,8	44,3	37,4	R1/8"	65	60	SP203-205/52	EX205G2	-	SPR1 SPR11 SPR12 SPR14	SCCE205	SCOE205-25	14,0	7,9	1,7	
	UCSP205	264	225	78	41	21	14,3	-	34	-	-	R1/8"	47,8	60	SP203-205/52	UC205G2	-	SPR1 SPR11 SPR12 SPR14	SCC205	SCO205-25	14,0	7,9	1,6	
	UKSP206H	274	225	98	41	21	-	20,5	25	38	45	R1/8"	50,8	70	SP206-207/62	UK206G2H	H2306	SPR2 SPR21 SPR22 SPR24	SCC206	SCO206-25	19,5	11,2	2,0	
	USSP205	264	225	78	41	21	7,5	-	27	-	-	R1/8"	47,8	60	SP203-205/52	US205G2	-	SPR2 SPR21 SPR22 SPR24	SCC205	SCO205-25	14,0	7,9	1,6	
30	ESSP206	274	225	98	41	21	9	-	23,8	35,7	44,1	R1/8"	69	70	SP206-207/62	ES206G2	-	SPR2 SPR21 SPR22 SPR24	SCCE206	SCOE206-30	19,5	11,2	1,9	30
	EXSP206	274	225	98	41	21	18,2	-	36,4	48,3	44,1	R1/8"	69	70	SP206-207/62	EX206G2	-	SPR2 SPR21 SPR22 SPR24	SCCE206	SCOE206-30	19,5	11,2	2,0	
	UCSP206	274	225	98	41	21	15,9	-	38,1	-	-	R1/8"	50,8	70	SP206-207/62	UC206G2	-	SPR2 SPR21 SPR22 SPR24	SCC206	SCO206-30	19,5	11,2	1,9	
	UKSP207H	274	225	98	41	21	-	22,5	27	43	52	R1/8"	54,4	80	SP206-207/72	UK207G2H	H2307	SPR2 SPR21 SPR22 SPR24	SCC207	SCO207-30	25,7	15,2	2,0	
	USSP206	274	225	98	41	21	8	-	30	-	-	R1/8"	50,8	70	SP206-207/62	US206G2	-	SPR2 SPR21 SPR22 SPR24	SCC206	SCO206-30	19,5	11,2	1,9	

* Bearing units that are ordered with cover(s) include the housings with grooves.
If you want to install the protective covers later, housings with suffix N must be ordered (for example: P210N).

**Stretcher frame must be ordered separately, pages 100, 101

CAST IRON HOUSINGS WITH CHROME STEEL BEARING INSERTS

TENSIONER- / HANG UP- / CARTRIDGE UNITS

Tensioner unit
SP2



Main dimensions [mm]

d	Unit	L	L1	H	H2	A	S	s1	B	B1	d1	G	Z	Dz	Housing	Bearing insert	Adapter sleeve	Stretcher frame **	Open protective cap *1	Closed protective cap *1	Dynamic load rating C [kN]	Static load rating C0 [kN]	Weight [kg]	d
35	ESSP207	274	225	98	41	21	9,5	-	25,4	38,9	51,1	R1/8"	73	80	SP206-207/72	ES207G2	-	SPR2 SPR21 SPR22 SPR24	SCCE207	SCOE207-35	25,7	15,2	2,0	35
	EXSP207	274	225	98	41	21	18,8	-	37,6	51,1	51,1	R1/8"	73	80	SP206-207/72	EX207G2	-	SPR2 SPR21 SPR22 SPR24	SCCE207	SCOE207-35	25,7	15,2	2,1	
	UCSP207	274	225	98	41	21	17,5	-	42,9	-	-	R1/8"	54,4	80	SP206-207/72	UC207G2	-	SPR2 SPR21 SPR22 SPR24	SCC207	SCO207-35	25,7	15,2	2,0	
	UKSP208H	320	260	120	61	31	-	24,5	29	46	58	R1/8"	69,3	88	SP208-210/80	UK208G2H	H2308	SPR2 SPR21 SPR22 SPR24	SCC208	SCO208-35	29,6	18,2	4,1	
	USSP207	274	225	98	41	21	8,5	-	32	-	-	R1/8"	54,4	80	SP206-207/72	US207G2	-	SPR2 SPR21 SPR22 SPR24	SCC207	SCO207-35	25,7	15,2	1,9	
40	ESSP208	320	260	120	61	31	11	-	30,2	43,7	58	R1/8"	81,5	88	SP208-210/80	ES208G2	-	SPR2 SPR21 SPR22 SPR24	SCCE208	SCOE208-40	29,6	18,2	4,1	40
	EXSP208	320	260	120	61	31	21,4	-	42,8	56,3	58	R1/8"	81,5	88	SP208-210/80	EX208G2	-	SPR2 SPR21 SPR22 SPR24	SCCE208	SCOE208-40	29,6	18,2	4,2	
	UCSP208	320	260	120	61	31	19	-	49,2	-	-	R1/8"	69,3	88	SP208-210/80	UC208G2	-	SPR2 SPR21 SPR22 SPR24	SCC208	SCO208-40	29,6	18,2	4,0	
	UKSP209H	320	260	120	61	31	-	26	30	50	65	R1/8"	69,3	95	SP208-210/85	UK209G2H	H2309	SPR2 SPR21 SPR22 SPR24	SCC209	SCO209-40	31,9	20,8	4,0	
	USSP208	320	260	120	61	31	9	-	34	-	-	R1/8"	69,3	88	SP208-210/80	US208G2	-	SPR2 SPR21 SPR22 SPR24	SCC208	SCO208-40	29,6	18,2	4,0	
45	ESSP209	320	260	120	61	31	11	-	30,2	43,7	62	R1/8"	83,5	95	SP208-210/85	ES209G2	-	SPR2 SPR21 SPR22 SPR24	SCCE209	SCOE209-45	31,9	20,8	3,9	45
	EXSP209	320	260	120	61	31	21,4	-	42,8	56,3	62	R1/8"	83,5	95	SP208-210/85	EX209G2	-	SPR2 SPR21 SPR22 SPR24	SCCE209	SCOE209-45	31,9	20,8	4,1	
	UCSP209	320	260	120	61	31	19	-	49,2	-	-	R1/8"	69,3	95	SP208-210/85	UC209G2	-	SPR2 SPR21 SPR22 SPR24	SCC209	SCO209-45	31,9	20,8	3,9	
	UKSP210H	320	260	120	61	31	-	27,5	31	55	70	R1/8"	75,1	100	SP208-210/90	UK210G2H	H2310	SPR2 SPR21 SPR22 SPR24	SCC210	SCO210-45	35,1	23,2	4,1	
	USSP209	320	260	120	61	31	10,2	-	41,2	-	-	R1/8"	69,3	95	SP208-210/85	US209G2	-	SPR2 SPR21 SPR22 SPR24	SCC209	SCO209-45	31,9	20,8	3,9	
50	ESSP210	320	260	120	61	31	11	-	30,2	43,7	67,2	R1/8"	90,5	100	SP208-210/90	ES210G2	-	SPR2 SPR21 SPR22 SPR24	SCCE210	SCOE210-50	35,1	23,2	3,9	50
	EXSP210	320	260	120	61	31	24,6	-	49,2	62,7	67,2	R1/8"	90,5	100	SP208-210/90	EX210G2	-	SPR2 SPR21 SPR22 SPR24	SCCE210	SCOE210-50	35,1	23,2	4,1	
	UCSP210	320	260	120	61	31	19	-	51,6	-	-	R1/8"	75,1	100	SP208-210/90	UC210G2	-	SPR2 SPR21 SPR22 SPR24	SCC210	SCO210-50	35,1	23,2	3,9	
	USSP210	320	260	120	61	31	10,9	-	43,5	-	-	R1/8"	75,1	100	SP208-210/90	US210G2	-	SPR2 SPR21 SPR22 SPR24	SCC210	SCO210-50	35,1	23,2	3,9	

* Bearing units that are ordered with cover(s) include the housings with grooves.
If you want to install the protective covers later, housings with suffix N must be ordered (for example: P210N).

**Stretcher frame must be ordered separately, pages 100, 101

CAST IRON HOUSINGS WITH CHROME STEEL BEARING INSERTS

TENSIONER- / HANG UP- / CARTRIDGE UNITS

Stretcher frame
SPR

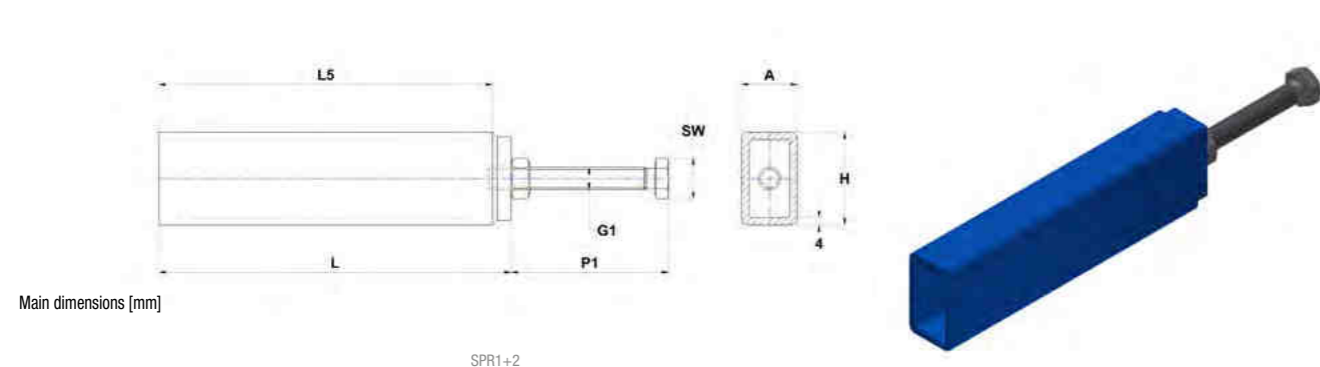

Main dimensions [mm]

SPR1+2

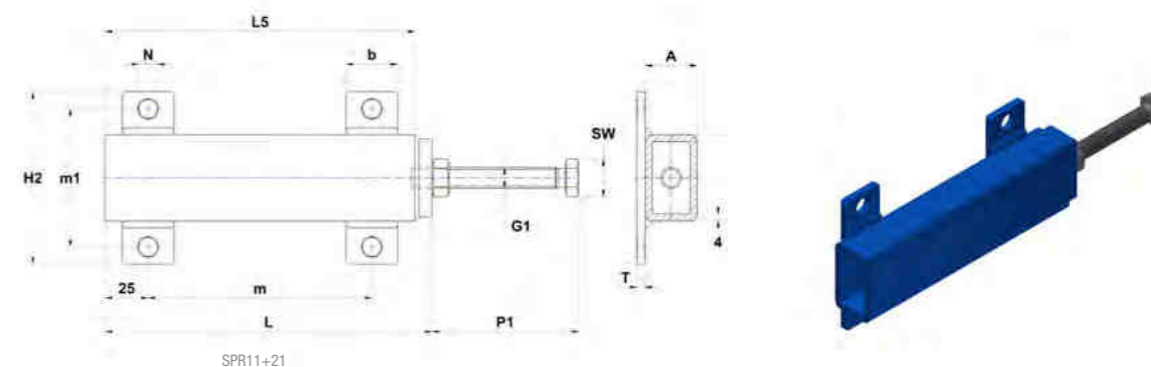

SPR11+21

Frame	Tensioner unit	L	L5	H	H2	m	m1	A	b	T	P1	G1	N	SW
SPR1	SP203-207	190	180	50	-	-	-	30	-	-	85	M12 x 90	-	18
SPR2	SPR208-210	225	210	70	-	-	-	40	-	-	105	M16 x 110	-	24
SPR11	SP203-207	190	180	50	100	130	80	30	30	5	85	M12 x 90	11	18
SPR21	SPR208-210	225	210	70	140	160	100	40	40	6	105	M16 x 110	14	24
SPR12	SP203-207	190	180	48	100	65	75	25	-	-	85	M12 x 90	10	18
SPR22	SPR208-210	225	210	68	130	80	100	35	-	-	105	M16 x 110	12	24
SPR14	SP203-207	190	180	48	103	140	80	25	-	-	97	M12 x 100	11,5	18
SPR24	SPR208-210	235	220	68	130	180	100	35	-	-	111	M16 x 120	14	24

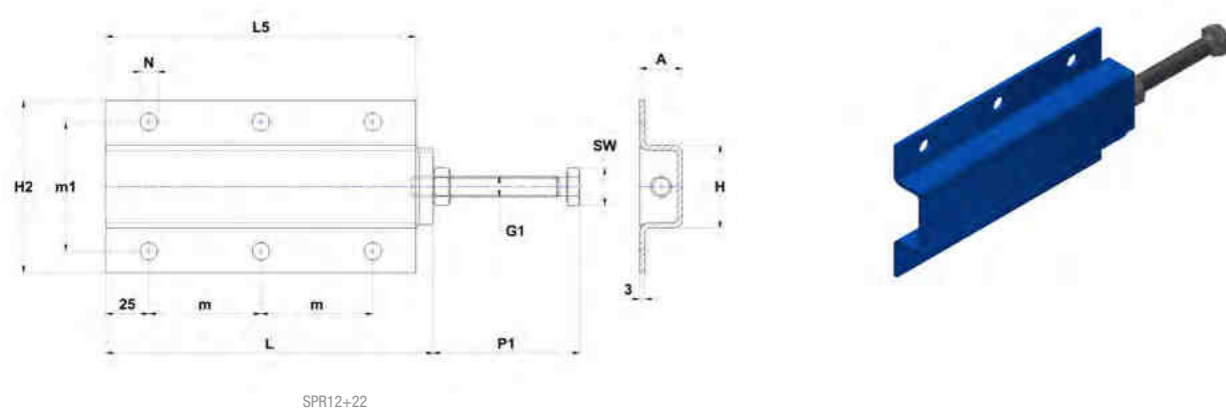

SPR12+22

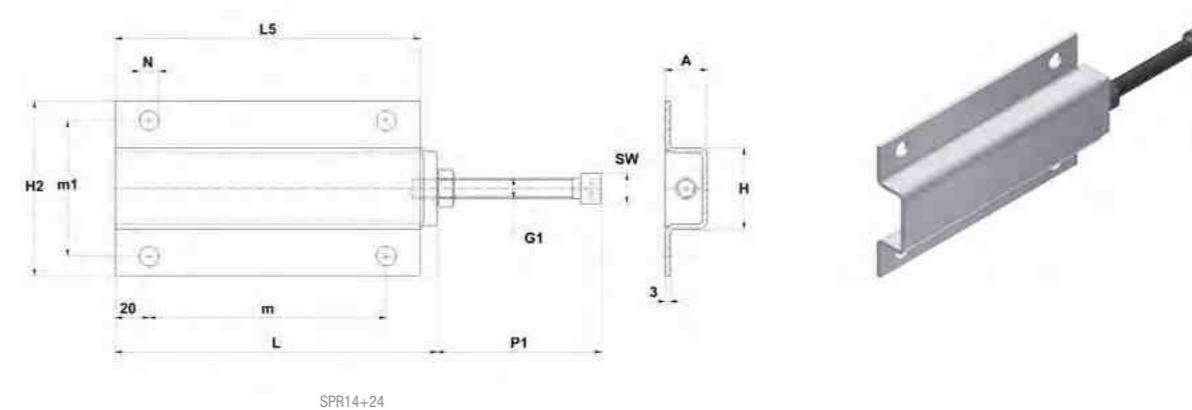

SPR14+24

CAST IRON HOUSINGS WITH CHROME STEEL BEARING INSERTS

TENSIONER- / HANG UP- / CARTRIDGE UNITS

Cartridge unit
C2

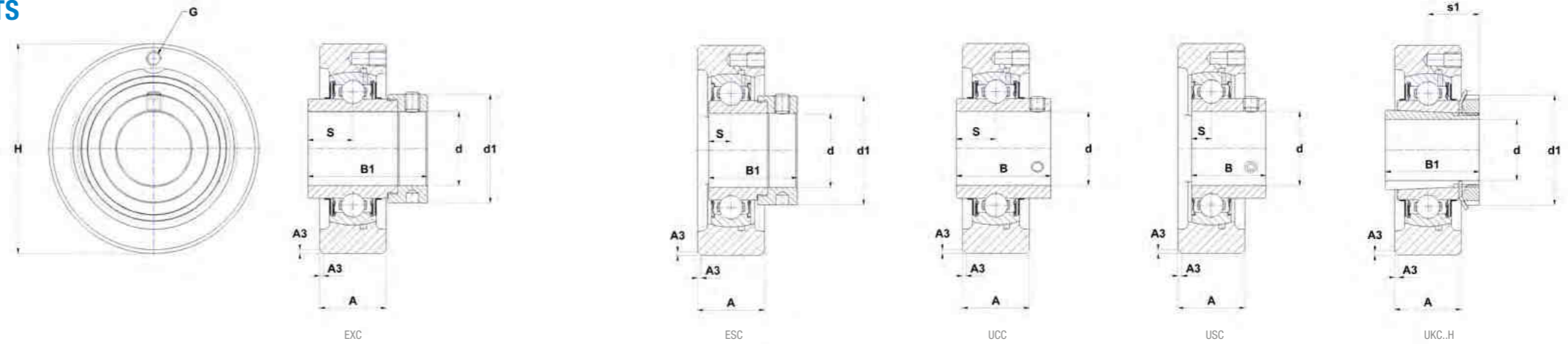

Main dimensions [mm]

d	Unit	H	A	A3	S	s1	B	B1	d1	G	Housing	Bearing insert	Adapter sleeve	Dynamic load rating C [kN]	Static load rating C0 [kN]	Weight [kg]	d
12	ESC201	67	20	1,5	6,5	-	19	28,6	27,2	M6x1	C203	ES201G2	-	9,6	4,8	0,4	12
	EXC201	72	20	1,5	17	-	34	43,5	32,4	M6x1	C204	EX201G2	-	12,8	6,7	0,6	
	UCC201	72	20	1,5	12,7	-	31	-	-	M6x1	C204	UC201G2	-	12,8	6,7	0,5	
	USC201	67	20	1,5	6	-	22	-	-	M6x1	C203	US201G2	-	9,6	4,8	0,4	
15	ESC202	67	20	1,5	6,5	-	19,1	28,6	27,2	M6x1	C203	ES202G2	-	9,6	4,8	0,4	15
	EXC202	72	20	1,5	17	-	34	43,5	32,4	M6x1	C204	EX202G2	-	12,8	6,7	0,6	
	UCC202	72	20	1,5	12,7	-	31	-	-	M6x1	C204	UC202G2	-	12,8	6,7	0,5	
	USC202	67	20	1,5	6	-	22	-	-	M6x1	C203	US202G2	-	9,6	4,8	0,4	
17	ESC203	67	20	1,5	6,5	-	19,1	28,6	27,2	M6x1	C203	ES203G2	-	9,6	4,8	0,4	17
	EXC203	72	20	1,5	17	-	34	43,5	32,4	M6x1	C204	EX203G2	-	12,8	6,7	0,6	
	UCC203	72	20	1,5	12,7	-	31	-	-	M6x1	C204	UC203G2	-	12,8	6,7	0,5	
	USC203	67	20	1,5	6	-	22	-	-	M6x1	C203	US203G2	-	9,6	4,8	0,4	
20	ESC204	72	20	1,5	7,5	-	21,4	30,9	32,4	M6x1	C204	ES204G2	-	12,8	6,7	0,5	20
	EXC204	72	20	1,5	17	-	34	43,5	32,4	M6x1	C204	EX204G2	-	12,8	6,7	0,5	
	UCC204	72	20	1,5	12,7	-	31	-	-	M6x1	C204	UC204G2	-	12,8	6,7	0,5	
	UKC205H	80	22	1,5	-	18,5	21	35	38	M6x1	C205	UK205G2H	H2305	14,0	7,9	0,6	
	USC204	72	20	1,5	7	-	25	-	-	M6x1	C204	US204G2	-	12,8	6,7	0,4	
25	ESC205	80	22	1,5	7,5	-	21,4	30,9	37,4	M6x1	C205	ES205G2	-	14,0	7,9	0,6	25
	EXC205	80	22	1,5	17,4	-	34,8	44,3	37,4	M6x1	C205	EX205G2	-	14,0	7,9	0,7	
	UCC205	80	22	1,5	14,3	-	34	-	-	M6x1	C205	UC205G2	-	14,0	7,9	0,6	
	UKC206H	85	27	1,5	-	20,5	25	38	45	M6x1	C206	UK206G2H	H2306	19,5	11,2	0,9	
	USC205	80	22	1,5	7,5	-	27	-	-	M6x1	C205	US205G2	-	14,0	7,9	0,6	
30	ESC206	85	27	1,5	9	-	23,8	35,7	44,1	M6x1	C206	ES206G2	-	19,5	11,2	0,8	30
	EXC206	85	27	1,5	18,2	-	36,4	48,3	44,1	M6x1	C206	EX206G2	-	19,5	11,2	0,9	
	UCC206	85	27	1,5	15,9	-	38,1	-	-	M6x1	C206	UC206G2	-	19,5	11,2	0,8	
	UKC207H	90	28	2	-	22,5	27	43	52	M6x1	C207	UK207G2H	H2307	25,7	15,2	0,9	
	USC206	85	27	1,5	8	-	30	-	-	M6x1	C206	US206G2	-	19,5	11,2	0,8	
35	ESC207	90	28	2	9,5	-	25,4	38,9	51,1	M6x1	C207	ES207G2	-	25,7	15,2	0,9	35
	EXC207	90	28	2	18,8	-	37,6	51,1	51,1	M6x1	C207	EX207G2	-	25,7	15,2	1,0	
	UCC207	90	28	2	17,5	-	42,9	-	-	M6x1	C207	UC207G2	-	25,7	15,2	0,9	
	UKC208H	100	30	2	-	24,5	29	46	58	M6x1	C208	UK208G2H	H2308	29,6	18,2	1,3	
	USC207	90	28	2	8,5	-	32	-	-	M6x1	C207	US207G2	-	25,7	15,2	0,8	

CAST IRON HOUSINGS WITH CHROME STEEL BEARING INSERTS

TENSIONER- / HANG UP- / CARTRIDGE UNITS

Cartridge unit
C2

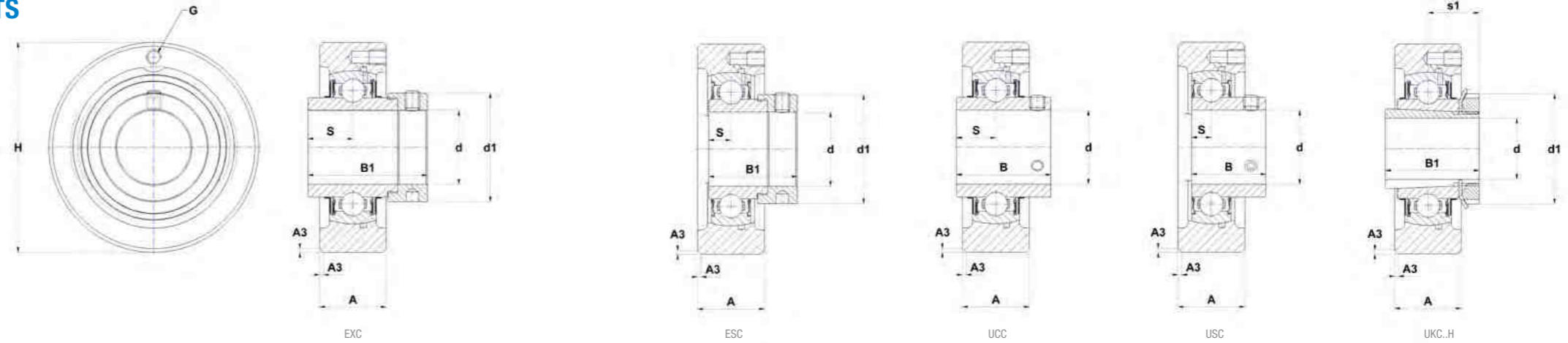

Main dimensions [mm]

d	Unit	H	A	A3	S	s1	B	B1	d1	G	Housing	Bearing insert	Adapter sleeve	Dynamic load rating C [kN]	Static load rating C0 [kN]	Weight [kg]	d
40	ESC208	100	30	2	11	-	30,2	43,7	58	M6x1	C208	ES208G2	-	29,6	18,2	1,3	40
	EXC208	100	30	2	21,4	-	42,8	56,3	58	M6x1	C208	EX208G2	-	29,6	18,2	1,4	
	UCC208	100	30	2	19	-	49,2	-	-	M6x1	C208	UC208G2	-	29,6	18,2	1,2	
	UKC209H	110	31	2	-	26	30	50	65	M6x1	C209	UK209G2H	H2309	31,9	20,8	1,6	
	USC208	100	30	2	9	-	34	-	-	M6x1	C208	US208G2	-	29,6	18,2	1,2	
45	ESC209	110	31	2	11	-	30,2	43,7	62	M6x1	C209	ES209G2	-	31,9	20,8	1,5	45
	EXC209	110	31	2	21,4	-	42,8	56,3	62	M6x1	C209	EX209G2	-	31,9	20,8	1,7	
	UCC209	110	31	2	19	-	49,2	-	-	M6x1	C209	UC209G2	-	31,9	20,8	1,5	
	UKC210H	120	31	2	-	27,5	31	55	70	M6x1	C210	UK210G2H	H2310	35,1	23,2	2,1	
	USC209	110	31	2	10,2	-	41,2	-	-	M6x1	C209	US209G2	-	31,9	20,8	1,5	
50	ESC210	120	31	2	11	-	30,2	43,7	67,2	M6x1	C210	ES210G2	-	35,1	23,2	1,9	50
	EXC210	120	31	2	24,6	-	49,2	62,7	67,2	M6x1	C210	EX210G2	-	35,1	23,2	2,1	
	UCC210	120	31	2	19	-	51,6	-	-	M6x1	C210	UC210G2	-	35,1	23,2	1,9	
	UKC211H	125	35	2,5	-	29	33	59	75	M6x1	C211	UK211G2H	H2311	43,6	29,2	2,3	
	USC210	120	31	2	10,9	-	43,5	-	-	M6x1	C210	US210G2	-	35,1	23,2	1,9	
55	ESC211	125	35	2,5	12	-	32,5	48,4	74,5	M6x1	C211	ES211G2	-	43,6	29,2	2,0	55
	EXC211	125	35	2,5	27,7	-	55,4	71,3	74,5	M6x1	C211	EX211G2	-	43,6	29,2	2,5	
	UCC211	125	35	2,5	22,2	-	55,6	-	-	M6x1	C211	UC211G2	-	43,6	29,2	2,2	
	UKC212H	130	38	2,5	-	31	36	62	80	M6x1	C212	UK212G2H	H2312	52,5	32,8	2,5	
	USC211	125	35	2,5	11,8	-	45,3	-	-	M6x1	C211	US211G2	-	43,6	29,2	2,2	
60	ESC212	130	38	2,5	12	-	33,4	49,3	82	M6x1	C212	ES212G2	-	52,5	32,8	2,2	60
	EXC212	130	38	2,5	30,9	-	61,8	77,7	82	M6x1	C212	EX212G2	-	52,5	32,8	2,9	
	UCC212	130	38	2,5	25,4	-	65,1	-	-	M6x1	C212	UC212G2	-	52,5	32,8	2,5	
	UKC213H	140	40	2,5	-	32	36	65	85	M6x1	C213	UK213G2H	H2313	57,2	40,0	3,0	
	USC212	130	38	2,5	14,9	-	53,7	-	-	M6x1	C212	US212G2	-	52,5	32,8	2,3	
65	EXC213	140	40	2,5	34,1	-	68,2	85,7	86	M6x1	C213	EX213G2	-	57,2	40,0	3,5	65
	UCC213	140	40	2,5	25,4	-	65,1	-	-	M6x1	C213	UC213G2	-	57,2	40,0	3,0	
	UKC215H	160	44	2	-	35,5	41	73	98	M6x1	C215	UK215G2H	H2315	66,0	49,5	4,8	
70	EXC214	150	44	2	34,1	-	68,2	85,7	96,8	M6x1	C214	EX214G2	-	62,0	45,0	4,2	70
	UCC214	150	44	2	30,2	-	74,6	-	-	M6x1	C214	UC214G2	-	62,0	45,0	3,7	
	UKC216H	170	48	2	-	39	44	78	105	M6x1	C216	UK216G2H	H2316	72,5	54,2	5,6	
75	EXC215	160	44	2	37,3	-	74,6	92,1	102	M6x1	C215	EX215G2	-	66,0	49,5	4,9	75
	UCC215	160	44	2	33,3	-	77,8	-	-	M6x1	C215	UC215G2	-	66,0	49,5	4,3	
80	EXC216	170	48	2	37,3	-	74,6	95,2	110	M6x1	C216	EX216G2	-	72,5	54,2	5,5	80
	UCC216	170	48	2	33,3	-	82,6	-	-	M6x1	C216	UC216G2	-	72,5	54,2	5,2	

Summary

CAST IRON HOUSINGS WITH CHROME STEEL BEARING INSERTS

TENSIONER- / HANG UP- / CARTRIDGE UNITS

Cartridge unit, heavy duty
C3

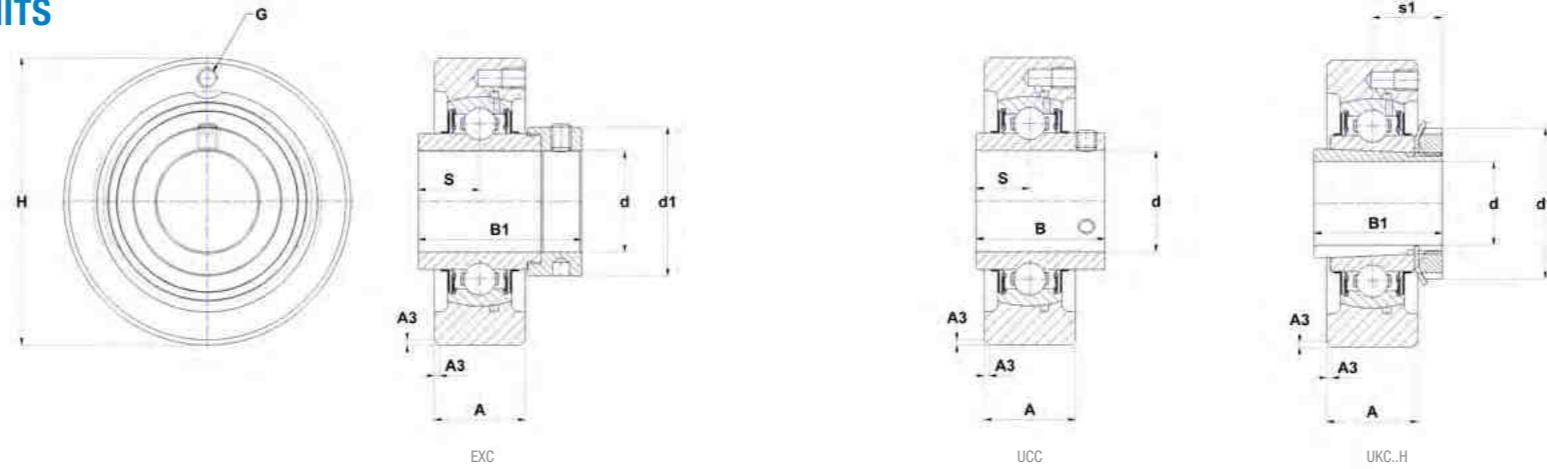

Main dimensions [mm]

d	Unit	H	A	A3	S	s1	B	B1	d1	G	Housing	Bearing insert	Adapter sleeve	Dynamic load rating C [kN]	Static load rating C0 [kN]	Weight [kg]	d
20	UKC305H	90	26	2,5	-	21,5	27	35	38	M6x1	C305	UK305G2H	H2305	22,4	11,5	1,1	20
25	EXC305	90	26	2,5	16,7	-	34,9	46,8	42,8	M6x1	C305	EX305G2	-	22,4	11,5	1,0	25
	UCC305	90	26	2,5	15	-	38	-	-	M6x1	C305	UC305G2	-	22,4	11,5	1,0	
	UKC306H	100	28	2,5	-	23	30	38	45	M6x1	C306	UK306G2H	H2306	27,0	15,2	1,3	
30	EXC306	100	28	2,5	17,5	-	36,5	50	50	M6x1	C306	EX306G2	-	27,0	15,2	1,4	30
	UCC306	100	28	2,5	17	-	43	-	-	M6x1	C306	UC306G2	-	27,0	15,2	1,3	
	UKC307H	110	32	3	-	25,5	33	43	52	M6x1	C307	UK307G2H	H2307	33,5	19,2	1,9	
35	EXC307	110	32	3	18,3	-	38,1	51,6	55	M6x1	C307	EX307G2	-	33,5	19,2	1,8	35
	UCC307	110	32	3	19	-	48	-	-	M6x1	C307	UC307G2	-	33,5	19,2	1,7	
	UKC308H	120	34	3	-	27,5	35	46	58	M6x1	C308	UK308G2H	H2308	40,6	24,0	2,2	
40	EXC308	120	34	3	19,8	-	41,3	57,1	63,5	M6x1	C308	EX308G2	-	40,6	24,0	2,3	40
	UCC308	120	34	3	19	-	52	-	-	M6x1	C308	UC308G2	-	40,6	24,0	2,2	
	UKC309H	130	38	3,5	-	30	38	50	65	M6x1	C309	UK309G2H	H2309	53,0	31,8	2,9	
45	EXC309	130	38	3,5	19,8	-	42,9	58,7	70	M6x1	C309	EX309G2	-	53,0	31,8	2,9	45
	UCC309	130	38	3,5	22	-	57	-	-	M6x1	C309	UC309G2	-	53,0	31,8	2,7	
	UKC310H	140	40	3,5	-	32	40	55	70	M6x1	C310	UK310G2H	H2310	62,0	37,8	3,4	
50	EXC310	140	40	3,5	24,6	-	49,2	66,6	76,2	M6x1	C310	EX310G2	-	62,0	37,8	3,6	50
	UCC310	140	40	3,5	22	-	61	-	-	M6x1	C310	UC310G2	-	62,0	37,8	3,4	
	UKC311H	150	44	3,5	-	34	43	59	75	M6x1	C311	UK311G2H	H2311	71,5	44,8	4,2	
55	EXC311	150	44	3,5	27,8	-	55,6	73	83	M6x1	C311	EX311G2	-	71,5	44,8	4,3	55
	UCC311	150	44	3,5	25	-	66	-	-	M6x1	C311	UC311G2	-	71,5	44,8	3,9	
	UKC312H	160	46	3,5	-	36,5	47	62	80	M6x1	C312	UK312G2H	H2312	81,6	51,8	4,7	
60	EXC312	160	46	3,5	31	-	61,9	79,4	89	M6x1	C312	EX312G2	-	81,6	51,8	5,1	60
	UCC312	160	46	3,5	26	-	71	-	-	M6x1	C312	UC312G2	-	81,6	51,8	4,8	
	UKC313H	170	50	3,5	-	38,5	49	65	85	M6x1	C313	UK313G2H	H2313	93,9	60,5	5,9	
65	EXC313	170	50	3,5	32,5	-	65,1	85,7	97	M6x1	C313	EX313G2	-	93,9	60,5	6,3	65
	UCC313	170	50	3,5	30	-	75	-	-	M6x1	C313	UC313G2	-	93,9	60,5	5,9	
	UKC315H	190	55	4	-	42,5	55	73	98	M10x1	C315	UK315G2H	H2315	113,4	76,8	8,2	
70	EXC314	180	52	4	34,2	-	68,3	92,1	102	M10x1	C314	EX314G2	-	104,3	68,0	7,3	70
	UCC314	180	52	4	33	-	78	-	-	M10x1	C314	UC314G2	-	104,3	68,0	6,8	
	UKC316H	200	60	4	-	44,5	55	78	105	M10x1	C316	UK316G2H	H2316	122,9	86,5	9,4	

CAST IRON HOUSINGS WITH CHROME STEEL BEARING INSERTS

TENSIONER- / HANG UP- / CARTRIDGE UNITS

Cartridge unit, heavy duty
C3

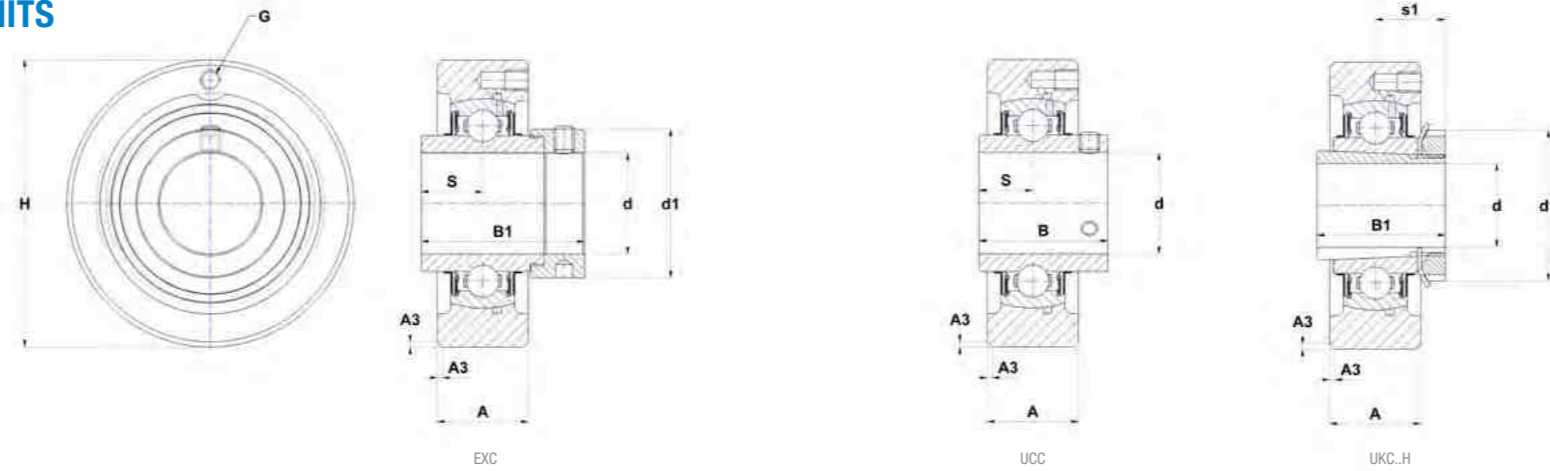

Main dimensions [mm]

d	Unit	H	A	A3	S	s1	B	B1	d1	G	Housing	Bearing insert	Adapter sleeve	Dynamic load rating C [kN]	Static load rating C0 [kN]	Weight [kg]	d
75	EXC315	190	55	4	37,3	-	74,6	100	113	M10x1	C315	EX315G2	-	113,4	76,8	8,5	75
	UCC315	190	55	4	32	-	82	-	-	M10x1	C315	UC315G2	-	113,4	76,8	7,5	
	UKC317H	215	64	4	-	48	60	82	110	M10x1	C317	UK317G2H	H2317	132,6	96,5	11,8	
80	EXC316	200	60	4	40,5	-	81	106,4	119	M10x1	C316	EX316G2	-	122,9	86,5	10,3	80
	UCC316	200	60	4	34	-	86	-	-	M10x1	C316	UC316G2	-	122,9	86,5	9,2	
	UKC318H	225	66	4	-	48	60	86	120	M10x1	C318	UK318G2H	H2318	143,0	108,0	13,2	
85	EXC317	215	64	4	42	-	84,1	109,5	127	M10x1	C317	EX317G2	-	132,6	96,5	12,9	85
	UCC317	215	64	4	40	-	96	-	-	M10x1	C317	UC317G2	-	132,6	96,5	11,7	
	UKC319H	240	72	4	-	52	66	90	125	M10x1	C319	UK319G2H	H2319	156,0	122,0	16,2	
90	EXC318	225	66	4	43,6	-	87,3	115,9	133	M10x1	C318	EX318G2	-	143,0	108,0	14,4	90
	UCC318	225	66	4	40	-	96	-	-	M10x1	C318	UC318G2	-	143,0	108,0	13,2	
	UKC320H	260	75	4	-	54	68	97	130	M10x1	C320	UK320G2H	H2320	171,6	140,0	19,9	
95	EXC319	240	72	4	46,8	-	93,7	122,3	140	M10x1	C319	EX319G2	-	156,0	122,0	17,4	95
	UCC319	240	72	4	41	-	103	-	-	M10x1	C319	UC319G2	-	156,0	122,0	15,9	
100	EXC320	260	75	4	50	-	100	128,6	146	M10x1	C320	EX320G2	-	171,6	140,0	21,9	100
	UCC320	260	75	4	42	-	108	-	-	M10x1	C320	UC320G2	-	171,6	140,0	20,1	
	UKC322H	300	80	5	-	61	80	105	145	M10x1	C322	UK322G2H	H2322	205,0	178,0	32,1	
105	UCC321	260	75	4	44	-	112	-	-	M10x1	C321	UC321G2	-	182,0	155,0	19,4	105
110	UCC322	300	80	5	46	-	117	-	-	M10x1	C322	UC322G2	-	205,0	178,0	28,8	110
	UKC324H	320	90	5	-	65,5	87	112	155	M10x1	C324	UK324G2H	H2324	228,0	208,0	38,7	
115	UKC326H	340	100	5	-	68	90	121	165	M10x1	C326	UK326G2H	H2326	252,0	242,0	48,8	115
120	UCC324	320	90	5	51	-	126	-	-	M10x1	C324	UC324G2	-	228,0	208,0	36,0	120
125	UKC328H	360	100	5	-	73	98	131	180	M10x1	C328	UK328G2H	H2328	275,0	272,0	56,8	125
130	UCC326	340	100	5	54	-	135	-	-	M10x1	C326	UC326G2	-	252,0	242,0	43,9	130
140	UCC328	360	100	5	59	-	145	-	-	M10x1	C328	UC328G2	-	275,0	272,0	50,8	140

CAST IRON HOUSINGS WITH CHROME STEEL BEARING INSERTS

TENSIONER- / HANG UP- / CARTRIDGE UNITS

Hang up unit
EHE2

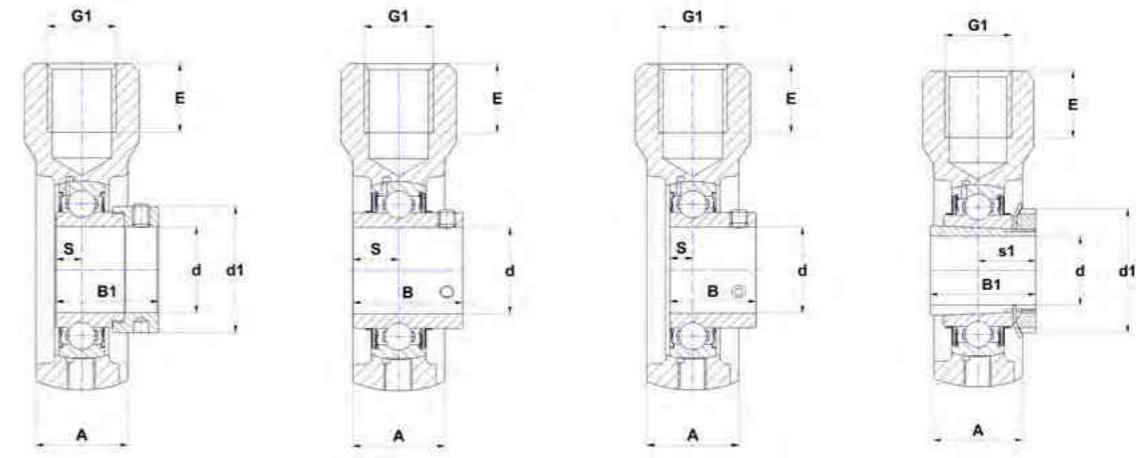
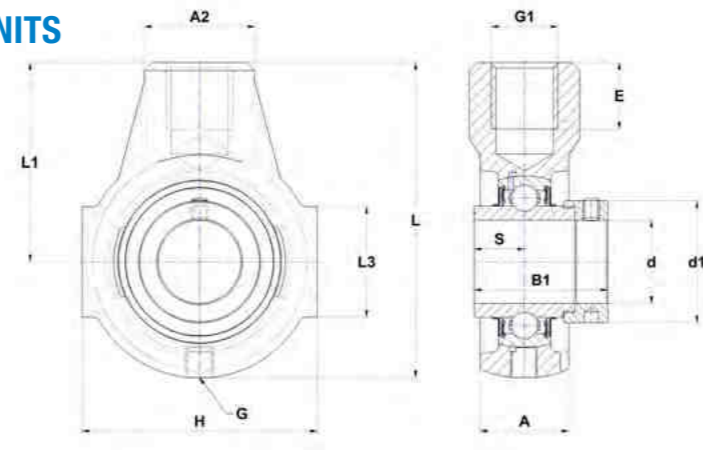

Main dimensions [mm]

d	Unit	L	L1	L3	H	A	A2	G1	E	S	s1	B	B1	d1	G	Housing	Bearing insert	Adapter sleeve	Dynamic load rating C [kN]	Static load rating C0 [kN]	Weight [kg]	d
12	ESEHE201	91	58	38	65	25	30	M16	21	6,5	-	19	28,6	27,2	M6x1	EHE203	ES201G2	-	9,6	4,8	0,6	12
	EXEHE201	91	58	38	65	25	30	M16	21	17	-	34	43,5	32,4	R1/8"	EHE204	EX201G2	-	12,8	6,7	0,7	
	UCEHE201	91	58	38	65	25	30	M16	21	12,7	-	31	-	-	R1/8"	EHE204	UC201G2	-	12,8	6,7	0,6	
	USEHE201	91	58	38	65	25	30	M16	21	6	-	22	-	-	M6x1	EHE203	US201G2	-	9,6	4,8	0,6	
15	ESEHE202	91	58	38	65	25	30	M16	21	6,5	-	19,1	28,6	27,2	M6x1	EHE203	ES202G2	-	9,6	4,8	0,6	15
	EXEHE202	91	58	38	65	25	30	M16	21	17	-	34	43,5	32,4	R1/8"	EHE204	EX202G2	-	12,8	6,7	0,7	
	UCEHE202	91	58	38	65	25	30	M16	21	12,7	-	31	-	-	R1/8"	EHE204	UC202G2	-	12,8	6,7	0,6	
	USEHE202	91	58	38	65	25	30	M16	21	6	-	22	-	-	M6x1	EHE203	US202G2	-	9,6	4,8	0,6	
17	ESEHE203	91	58	38	65	25	30	M16	21	6,5	-	19,1	28,6	27,2	M6x1	EHE203	ES203G2	-	9,6	4,8	0,6	17
	EXEHE203	91	58	38	65	25	30	M16	21	17	-	34	43,5	32,4	R1/8"	EHE204	EX203G2	-	12,8	6,7	0,7	
	UCEHE203	91	58	38	65	25	30	M16	21	12,7	-	31	-	-	R1/8"	EHE204	UC203G2	-	12,8	6,7	0,6	
	USEHE203	91	58	38	65	25	30	M16	21	6	-	22	-	-	M6x1	EHE203	US203G2	-	9,6	4,8	0,6	
20	ESEHE204	91	58	38	65	25	30	M16	21	7,5	-	21,4	30,9	32,4	R1/8"	EHE204	ES204G2	-	12,8	6,7	0,6	20
	EXEHE204	91	58	38	65	25	30	M16	21	17	-	34	43,5	32,4	R1/8"	EHE204	EX204G2	-	12,8	6,7	0,6	
	UCEHE204	91	58	38	65	25	30	M16	21	12,7	-	31	-	-	R1/8"	EHE204	UC204G2	-	12,8	6,7	0,6	
	UKEHE205H	99	64	38	70	28	35	M20	22	-	18,5	21	35	38	R1/8"	EHE205	UK205G2H	H2305	14,0	7,9	0,7	
	USEHE204	91	58	38	65	25	30	M16	21	7	-	25	-	-	R1/8"	EHE204	US204G2	-	12,8	6,7	0,5	
25	ESEHE205	99	64	38	70	28	35	M20	22	7,5	-	21,4	30,9	37,4	R1/8"	EHE205	ES205G2	-	14,0	7,9	0,7	25
	EXEHE205	99	64	38	70	28	35	M20	22	17,4	-	34,8	44,3	37,4	R1/8"	EHE205	EX205G2	-	14,0	7,9	0,8	
	UCEHE205	99	64	38	70	28	35	M20	22	14,3	-	34	-	-	R1/8"	EHE205	UC205G2	-	14,0	7,9	0,7	
	UKEHE206H	114	72	40	85	32	40	M24	24	-	20,5	25	38	45	R1/8"	EHE206	UK206G2H	H2306	19,5	11,2	1,1	
	USEHE205	99	64	38	70	28	35	M20	22	7,5	-	27	-	-	R1/8"	EHE205	US205G2	-	14,0	7,9	0,7	
30	ESEHE206	114	72	40	85	32	40	M24	24	9	-	23,8	35,7	44,1	R1/8"	EHE206	ES206G2	-	19,5	11,2	1,0	30
	EXEHE206	114	72	40	85	32	40	M24	24	18,2	-	36,4	48,3	44,1	R1/8"	EHE206	EX206G2	-	19,5	11,2	1,1	
	UCEHE206	114	72	40	85	32	40	M24	24	15,9	-	38,1	-	-	R1/8"	EHE206	UC206G2	-	19,5	11,2	1,0	
	UKEHE207H	122	76	40	90	32	40	M24	24	-	22,5	27	43	52	R1/8"	EHE207	UK207G2H	H2307	25,7	15,2	1,2	
	USEHE206	114	72	40	85	32	40	M24	24	8	-	30	-	-	R1/8"	EHE206	US206G2	-	19,5	11,2	1,0	
35	ESEHE207	122	76	40	90	32	40	M24	24	9,5	-	25,4	38,9	51,1	R1/8"	EHE207	ES207G2	-	25,7	15,2	1,2	35
	EXEHE207	122	76	40	90	32	40	M24	24	18,8	-	37,6	51,1	51,1	R1/8"	EHE207	EX207G2	-	25,7	15,2	1,3	
	UCEHE207	122	76	40	90	32	40	M24	24	17,5	-	42,9	-	-	R1/8"	EHE207	UC207G2	-	25,7	15,2	1,2	
	UKEHE208H	135	85	45	100	36	40	M24	24	-	24,5	29	46	58	R1/8"	EHE208	UK208G2H	H2308	29,6	18,2	1,6	
	USEHE207	122	76	40	90	32	40	M24	24	8,5	-	32	-	-	R1/8"	EHE207	US207G2	-	25,7	15,2	1,1	

CAST IRON HOUSINGS WITH CHROME STEEL BEARING INSERTS

TENSIONER- / HANG UP- / CARTRIDGE UNITS

Hang up unit
EHE2

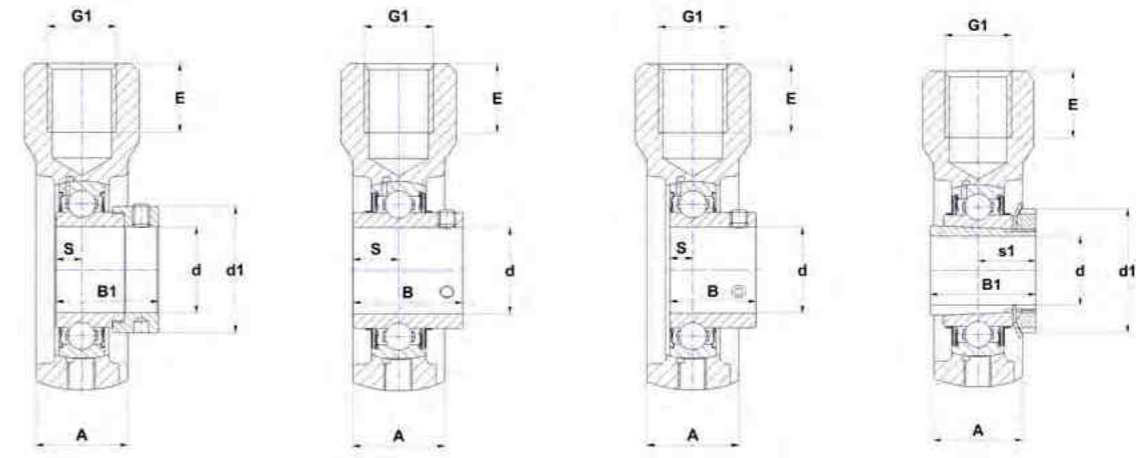
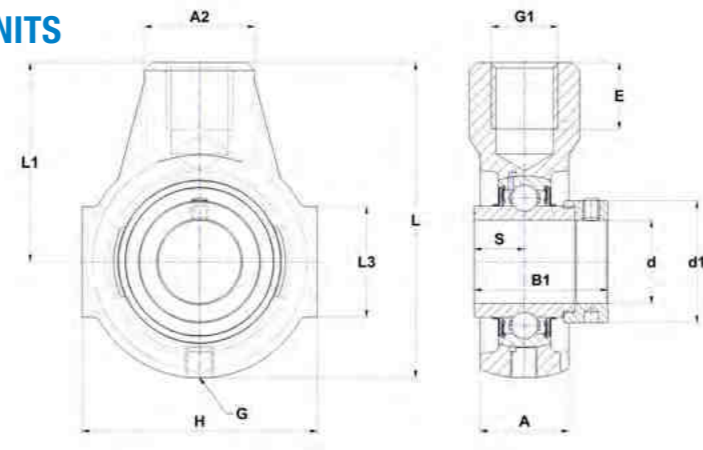

Main dimensions [mm]

d	Unit	L	L1	L3	H	A	A2	G1	E	S	s1	B	B1	d1	G	Housing	Bearing insert	Adapter sleeve	Dynamic load rating C [kN]	Static load rating C0 [kN]	Weight [kg]	d
40	ESEHE208	135	85	45	100	36	40	M24	24	11	-	30,2	43,7	58	R1/8"	EHE208	ES208G2	-	29,6	18,2	1,6	40
	EXEHE208	135	85	45	100	36	40	M24	24	21,4	-	42,8	56,3	58	R1/8"	EHE208	EX208G2	-	29,6	18,2	1,7	
	UCEHE208	135	85	45	100	36	40	M24	24	19	-	49,2	-	-	R1/8"	EHE208	UC208G2	-	29,6	18,2	1,5	
	UKEHE209H	145	90	45	110	40	40	M24	24	-	26	30	50	65	R1/8"	EHE209	UK209G2H	H2309	31,9	20,8	2,0	
	USEHE208	135	85	45	100	36	40	M24	24	9	-	34	-	-	R1/8"	EHE208	US208G2	-	29,6	18,2	1,5	
45	ESEHE209	145	90	45	110	40	40	M24	24	11	-	30,2	43,7	62	R1/8"	EHE209	ES209G2	-	31,9	20,8	1,9	45
	EXEHE209	145	90	45	110	40	40	M24	24	21,4	-	42,8	56,3	62	R1/8"	EHE209	EX209G2	-	31,9	20,8	2,1	
	UCEHE209	145	90	45	110	40	40	M24	24	19	-	49,2	-	-	R1/8"	EHE209	UC209G2	-	31,9	20,8	1,9	
	UKEHE210H	145	90	46	110	40	40	M24	24	-	27,5	31	55	70	R1/8"	EHE210	UK210G2H	H2310	35,1	23,2	2,0	
	USEHE209	145	90	45	110	40	40	M24	24	10,2	-	41,2	-	-	R1/8"	EHE209	US209G2	-	31,9	20,8	1,9	
50	ESEHE210	145	90	46	110	40	40	M24	24	11	-	30,2	43,7	67,2	R1/8"	EHE210	ES210G2	-	35,1	23,2	1,8	50
	EXEHE210	145	90	46	110	40	40	M24	24	24,6	-	49,2	62,7	67,2	R1/8"	EHE210	EX210G2	-	35,1	23,2	2,0	
	UCEHE210	145	90	46	110	40	40	M24	24	19	-	51,6	-	-	R1/8"	EHE210	UC210G2	-	35,1	23,2	1,8	
	USEHE210	145	90	46	110	40	40	M24	24	10,9	-	43,5	-	-	R1/8"	EHE210	US210G2	-	35,1	23,2	1,8	

PRESSED STEEL HOUSINGS WITH CHROME STEEL BEARING INSERTS

PILLOW BLOCK UNITS

Pillow block
PP2

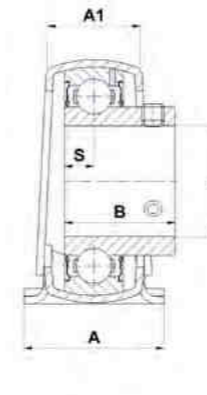
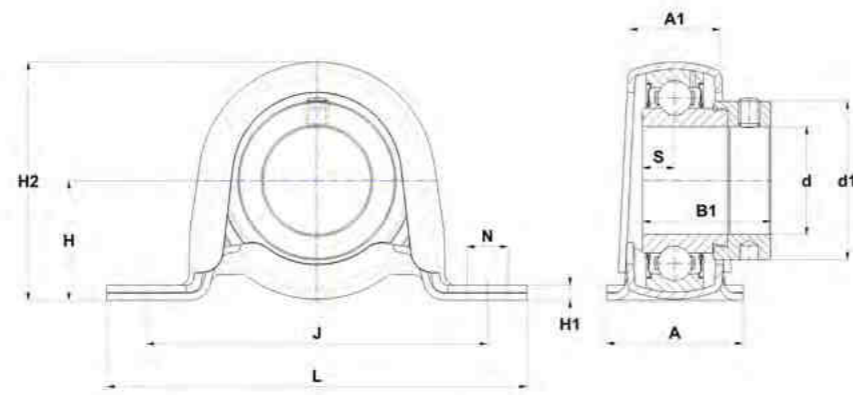

Main dimensions [mm]

d	Unit	L	J	H	H1	H2	A	A1	N	S	B	B1	d1	Housing	Bearing insert	Dynamic load rating C [kN]	Static load rating C0 [kN]	Weight [kg]	d
12	ESPP201	85,7	68	22,2	2,4	43,2	25,4	15,9	9	6,5	19	28,6	27,2	PP203	ES201G2	9,6	4,8	0,2	12
	USPP201	85,7	68	22,2	2,4	43,2	25,4	15,9	9	6	22	-	-	PP203	US201G2	9,6	4,8	0,2	
15	ESPP202	85,7	68	22,2	2,4	43,2	25,4	15,9	9	6,5	19,1	28,6	27,2	PP203	ES202G2	9,6	4,8	0,2	15
	USPP202	85,7	68	22,2	2,4	43,2	25,4	15,9	9	6	22	-	-	PP203	US202G2	9,6	4,8	0,2	
17	ESPP203	85,7	68	22,2	2,4	43,2	25,4	15,9	9	6,5	19,1	28,6	27,2	PP203	ES203G2	9,6	4,8	0,2	17
	USPP203	85,7	68	22,2	2,4	43,2	25,4	15,9	9	6	22	-	-	PP203	US203G2	9,6	4,8	0,2	
20	ESPP204	98,4	76	25,4	2,4	49,9	31,7	21,6	9	7,5	21,4	30,9	32,4	PP204	ES204G2	12,8	6,7	0,3	20
	USPP204	98,4	76	25,4	2,4	49,9	31,7	21,6	9	7	25	-	-	PP204	US204G2	12,8	6,7	0,2	
25	ESPP205	108	86	28,6	2,8	55,8	31,7	21,6	11	7,5	21,4	30,9	37,4	PP205	ES205G2	14,0	7,9	0,3	25
	USPP205	108	86	28,6	2,8	55,8	31,7	21,6	11	7,5	27	-	-	PP205	US205G2	14,0	7,9	0,3	
30	ESPP206	117,5	95	33,3	3,6	65,7	37,5	25,5	11	9	23,8	35,7	44,1	PP206	ES206G2	19,5	11,2	0,5	30
	USPP206	117,5	95	33,3	3,6	65,7	37,5	25,5	11	8	30	-	-	PP206	US206G2	19,5	11,2	0,5	
35	ESPP207	128,6	106	39,7	4,4	77,5	41	28,4	11	9,5	25,4	38,9	51,1	PP207	ES207G2	25,7	15,2	0,7	35
	USPP207	128,6	106	39,7	4,4	77,5	41	28,4	11	8,5	32	-	-	PP207	US207G2	25,7	15,2	0,6	

PRESSED STEEL HOUSINGS WITH CHROME STEEL BEARING INSERTS

FLANGED UNITS

Three or four-bolt flange, round design

PF2

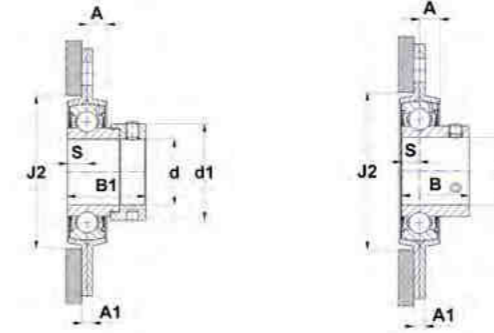
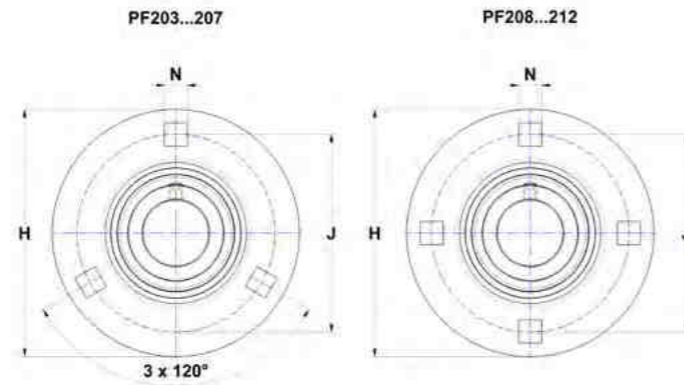

Main dimensions [mm]

d	Unit	H	J	J2	A	A1	N	S	B	B1	d1	Housing	Bearing insert	Dynamic load rating C [kN]	Static load rating C0 [kN]	Weight [kg]	d
12	ESPF201	81	63,5	49	6,7	4	7,1	6,5	19	28,6	27,2	PF203	ES201G2	9,6	4,8	0,2	12
	USPF201	81	63,5	49	6,7	4	7,1	6	22	-	-	PF203	US201G2	9,6	4,8	0,2	
15	ESPF202	81	63,5	49	6,7	4	7,1	6,5	19,1	28,6	27,2	PF203	ES202G2	9,6	4,8	0,2	15
	USPF202	81	63,5	49	6,7	4	7,1	6	22	-	-	PF203	US202G2	9,6	4,8	0,2	
17	ESPF203	81	63,5	49	6,7	4	7,1	6,5	19,1	28,6	27,2	PF203	ES203G2	9,6	4,8	0,2	17
	USPF203	81	63,5	49	6,7	4	7,1	6	22	-	-	PF203	US203G2	9,6	4,8	0,2	
20	ESPF204	90,5	71,5	55	7,7	4	8,7	7,5	21,4	30,9	32,4	PF204	ES204G2	12,8	6,7	0,4	20
	USPF204	90,5	71,5	55	7,7	4	8,7	7	25	-	-	PF204	US204G2	12,8	6,7	0,3	
25	ESPF205	95,2	76	60	8,7	4	8,7	7,5	21,4	30,9	37,4	PF205	ES205G2	14,0	7,9	0,4	25
	USPF205	95,2	76	60	8,7	4	8,7	7,5	27	-	-	PF205	US205G2	14,0	7,9	0,4	
30	ESPF206	114	90,5	72	20	5,5	11	9	23,8	35,7	44,1	PF206	ES206G2	19,5	11,2	0,6	30
	USPF206	114	90,5	72	20	5,5	11	8	30	-	-	PF206	US206G2	19,5	11,2	0,6	
35	ESPF207	126,5	100	81	10,8	5	11	9,5	25,4	38,9	51,1	PF207	ES207G2	25,7	15,2	0,9	35
	USPF207	126,5	100	81	10,8	5	11	8,5	32	-	-	PF207	US207G2	25,7	15,2	0,8	
40	ESPF208	147,8	119	91	10	7	13,5	11	30,2	43,7	58	PF208	ES208G2	29,6	18,2	1,4	40
	USPF208	147,8	119	91	10	7	13,5	9	34	-	-	PF208	US208G2	29,6	18,2	1,3	
45	ESPF209	149,2	120,5	97	10	7	13,5	11	30,2	43,7	62	PF209	ES209G2	31,9	20,8	1,4	45
	USPF209	149,2	120,5	97	10	7	13,5	10,2	41,2	-	-	PF209	US209G2	31,9	20,8	1,4	
50	ESPF210	155,6	127	102	10,5	8	13,5	11	30,2	43,7	67,2	PF210	ES210G2	35,1	23,2	1,7	50
	USPF210	155,6	127	102	10,5	8	13,5	10,9	43,5	-	-	PF210	US210G2	35,1	23,2	1,7	
55	ESPF211	166,6	138	113	10,7	8	13,5	12	32,5	48,4	74,5	PF211	ES211G2	43,6	29,2	1,9	55
	USPF211	166,6	138	113	10,7	8	13,5	11,8	45,3	-	-	PF211	US211G2	43,6	29,2	2,1	
60	ESPF212	176,2	147,6	122	11,9	8	13,5	12	33,4	49,3	82	PF212	ES212G2	52,5	32,8	2,3	60
	USPF212	176,2	147,6	122	11,9	8	13,5	14,9	53,7	-	-	PF212	US212G2	52,5	32,8	2,4	

PRESSED STEEL HOUSINGS WITH CHROME STEEL BEARING INSERTS

FLANGED UNITS

Two-bolt flange, oval design

PFL2

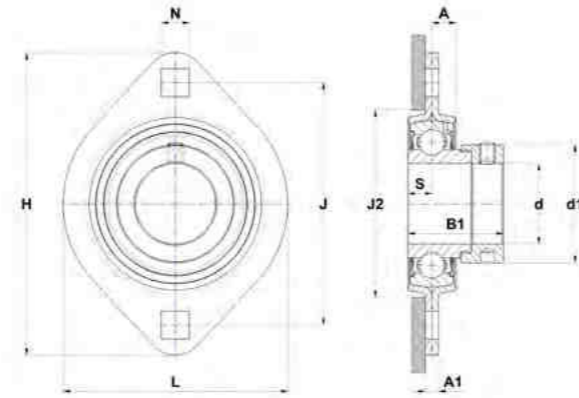

ESPFL

USPFL

Main dimensions [mm]

d	Unit	H	J	J2	A	A1	N	S	B	B1	d1	Housing	Bearing insert	Dynamic load rating C [kN]	Static load rating C0 [kN]	Weight [kg]	d
12	ESPFL201	81	63,5	49	6,7	4	7,1	6,5	19	28,6		PFL203	ES201G2	9,55	4,78	0,24	12
	USPFL201	81	63,5	49	6,7	4	7,1	6	22	-	-	PFL203	US201G2	9,55	4,78	0,19	
15	ESPFL202	81	63,5	49	6,7	4	7,1	6,5	19,1	28,6	27,2	PFL203	ES202G2	9,55	4,78	0,23	15
	USPFL202	81	63,5	49	6,7	4	7,1	6	22	-	-	PFL203	US202G2	9,55	4,78	0,18	
17	ESPFL203	81	63,5	49	6,7	4	7,1	6,5	19,1	28,6	27,2	PFL203	ES203G2	9,55	4,78	0,23	17
	USPFL203	81	63,5	49	6,7	4	7,1	6	22	-	-	PFL203	US203G2	9,55	4,78	0,2	
20	ESPFL204	91	71,5	56	7,7	4,5	9	7,5	21,4	30,9	32,4	PFL204	ES204G2	12,8	6,65	0,25	20
	USPFL204	91	71,5	56	7,7	4,5	9	7	25	-	-	PFL204	US204G2	12,8	6,65	0,23	
25	ESPFL205	95,2	76,2	60	8,7	4	8,7	7,5	21,4	30,9	37,4	PFL205	ES205G2	14	7,88	0,29	25
	USPFL205	95,2	76,2	60	8,7	4	8,7	7,5	27	-	-	PFL205	US205G2	14	7,88	0,27	
30	ESPFL206	112,7	90,5	71	9	5	10,5	9	23,8	35,7	44,1	PFL206	ES206G2	19,5	11,2	0,53	30
	USPFL206	112,7	90,5	71	9	5	10,5	8	30	-	-	PFL206	US206G2	19,5	11,2	0,47	
35	ESPFL207	123	100	81	10,5	5	10,5	9,5	25,4	38,9	51,1	PFL207	ES207G2	25,7	15,2	0,7	35
	USPFL207	123	100	81	10,5	5	10,5	8,5	32	-	-	PFL207	US207G2	25,7	15,2	0,62	
40	ESPFL208	151	119	91	11,5	7	13,5	11	30,2	43,7	58	PFL208	ES208G2	29,6	18,2	0,95	40
	USPFL208	151	119	91	11,5	7	13,5	9	34	-	-	PFL208	US208G2	29,6	18,2	0,9	

PRESSED STEEL HOUSINGS WITH CHROME STEEL BEARING INSERTS

FLANGED UNITS

Three-bolt flange, triangular design
PFT2

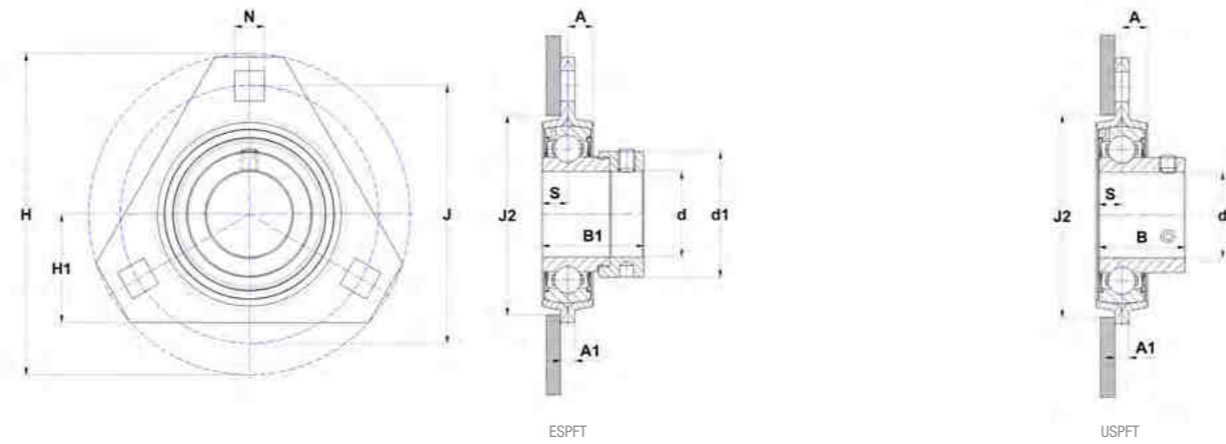

Main dimensions [mm]

d	Unit	H	H1	J	J2	A	A1	N	S	B	B1	d1	Housing	Bearing insert	Dynamic load rating C [kN]	Static load rating C0 [kN]	Weight [kg]	d
20	ESPFT204	90,5	33,3	71,5	55	7,2	4	8,7	7,5	21,4	30,9	32,4	PFT204	ES204G2	12,8	6,7	0,3	20
	USPFT204	90,5	33,3	71,5	55	7,2	4	8,7	7	25	-	-	PFT204	US204G2	12,8	6,7	0,2	
25	ESPFT205	95,2	34,2	76	60	8,7	4	8,7	7,5	21,4	30,9	37,4	PFT205	ES205G2	14,0	7,9	0,3	25
	USPFT205	95,2	34,2	76	60	8,7	4	8,7	7,5	27	-	-	PFT205	US205G2	14,0	7,9	0,3	
30	ESPFT206	112,7	40,2	90,5	71	10,5	5	10,5	9	23,8	35,7	44,1	PFT206	ES206G2	19,5	11,2	0,5	30
	USPFT206	112,7	40,2	90,5	71	10,5	5	10,5	8	30	-	-	PFT206	US206G2	19,5	11,2	0,5	
35	ESPFT207	122,2	44,2	100	81	10,5	5	10,5	9,5	25,4	38,9	51,1	PFT207	ES207G2	25,7	15,2	0,7	35
	USPFT207	122,2	44,2	100	81	10,5	5	10,5	8,5	32	-	-	PFT207	US207G2	25,7	15,2	0,6	

TAKE-UP UNITS

Take-up unit for shaft adjustment, rectangular design
PFE2

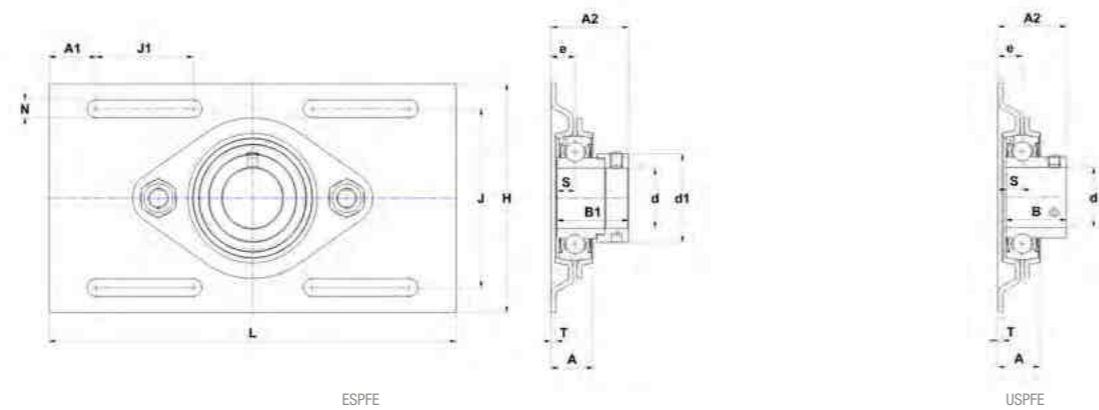

Main dimensions [mm]

d	UNIT	L	H	J	J1	A	A1	A2	e	N	T	S	B	B1	d1	Housing	Bearing insert	Dynamic load rating C [kN]	Static load rating C0 [kN]	Weight [kg]	d
25	ESPFE205	203,2	104,8	80,2	48,5	19	23,4	33,7	10,3	8,7	2	7,5	-	30,9	37,4	PFE205	ES205G2	14,0	7,9	0,6	25
	USPFE205	203,2	104,8	80,2	48,5	19	23,4	29,8	10,3	8,7	2	7,5	27	-	-	PFE205	US205G2	14,0	7,9	0,6	
30	ESPFE206	203,2	114,3	89,2	48,5	21,1	23,4	38,8	12,1	8,7	2,5	9	-	35,7	44,1	PFE206	ES206G2	19,5	11,2	0,8	30
	USPFE206	203,2	114,3	89,2	48,5	21,1	23,4	34,1	12,1	8,7	2,5	8	30	-	-	PFE206	US206G2	19,5	11,2	0,8	

The connecting bolts of the sheet metal parts are attached to the units

CHROME STEEL BEARING INSERTS WITH SPHERICAL OUTER RING

ECCENTRIC LOCKING COLLAR TYPES

Basic version

EX2..G2

ES2..G2

Heavy duty

EX3..G2

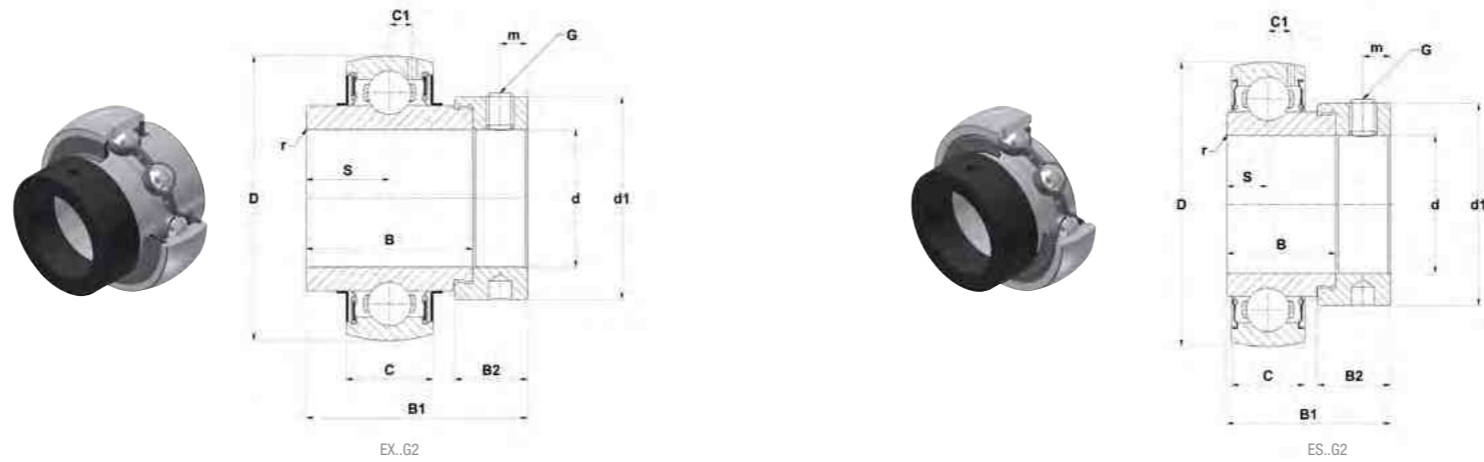

Main dimensions [mm]

d	Bearing insert	D	C	B	B1	B2	d1	S	m	C1	r min	G	SW*	Set screw torque [Nm]	min Temp [°C]	max Temp [°C]	Dynamic load rating C [kN]	Static load rating C0 [kN]	Weight [kg]	d
12	ES201G2	40	12	19	28,6	13,5	27,2	6,5	5	3,6	0,6	M6x1	3	5,5	-20	100	9,6	4,8	0,1	12
	EX201G2	47	16	34	43,5	13,5	32,4	17	5	4,4	0,6	M6x1	3	5,5	-20	100	12,8	6,7	0,3	
15	ES202G2	40	12	19,1	28,6	13,5	27,2	6,5	5	3,6	0,6	M6x1	3	5,5	-20	100	9,6	4,8	0,1	15
	EX202G2	47	16	34	43,5	13,5	32,4	17	5	4,4	0,6	M6x1	3	5,5	-20	100	12,8	6,7	0,3	
17	ES203G2	40	12	19,1	28,6	13,5	27,2	6,5	5	3,6	0,6	M6x1	3	5,5	-20	100	9,6	4,8	0,1	17
	EX203G2	47	16	34	43,5	13,5	32,4	17	5	4,4	0,6	M6x1	3	5,5	-20	100	12,8	6,7	0,3	
20	ES204G2	47	14	21,4	30,9	13,5	32,4	7,5	5	4	0,6	M6x1	3	5,5	-20	100	12,8	6,7	0,2	20
	EX204G2	47	16	34	43,5	13,5	32,4	17	5	4,4	0,6	M6x1	3	5,5	-20	100	12,8	6,7	0,2	
25	ES205G2	52	15	21,4	30,9	13,5	37,4	7,5	5	4,3	0,6	M6x1	3	5,5	-20	100	14,0	7,9	0,2	25
	EX205G2	52	17	34,8	44,3	13,5	37,4	17,4	5	4,3	0,6	M6x1	3	5,5	-20	100	14,0	7,9	0,3	
	EX305G2	62	21	34,9	46,8	15,9	42,8	16,7	6	6,2	1,5	M8x1	4	11,5	-20	100	22,4	11,5	0,4	
30	ES206G2	62	16	23,8	35,7	15,9	44,1	9	6	5	0,6	M8x1	4	11,5	-20	100	19,5	11,2	0,3	30
	EX206G2	62	19	36,4	48,3	15,9	44,1	18,2	6	5	0,6	M8x1	4	11,5	-20	100	19,5	11,2	0,4	
	EX306G2	72	24	36,5	50	17,5	50	17,5	6,7	6,5	1,5	M8x1	4	11,5	-20	100	27,0	15,2	0,7	
35	ES207G2	72	17	25,4	38,9	17,5	51,1	9,5	6,5	5,7	1,1	M8x1	4	11,5	-20	100	25,7	15,2	0,5	35
	EX207G2	72	20	37,6	51,1	17,5	51,1	18,8	6,5	5,8	1,1	M8x1	4	11,5	-20	100	25,7	15,2	0,6	
	EX307G2	80	25	38,1	51,6	17,5	55	18,3	6,7	7,2	2	M8x1	4	11,5	-20	100	33,5	19,2	0,8	
40	ES208G2	80	18	30,2	43,7	18,3	58	11	6,5	6,2	1,1	M8x1	4	11,5	-20	100	29,6	18,2	0,7	40
	EX208G2	80	21	42,8	56,3	18,3	58	21,4	6,5	6,3	1,1	M8x1	4	11,5	-20	100	29,6	18,2	0,8	
	EX308G2	90	28	41,3	57,1	20,6	63,5	19,8	8	8,5	2	M10x1,25	5	22	-20	100	40,6	24,0	1,1	
45	ES209G2	85	19	30,2	43,7	18,3	62	11	6,5	6,5	1,1	M8x1	4	11,5	-20	100	31,9	20,8	0,7	45
	EX209G2	85	22	42,8	56,3	18,3	62	21,4	6,5	6,8	1,1	M8x1	4	11,5	-20	100	31,9	20,8	0,9	
	EX309G2	100	30	42,9	58,7	20,6	70	19,8	8	9	2	M10x1,25	5	22	-20	100	53,0	31,8	1,5	
50	ES210G2	90	20	30,2	43,7	18,3	67,2	11	6,5	6,5	1,1	M8x1	4	11,5	-20	100	35,1	23,2	0,8	50
	EX210G2	90	23	49,2	62,7	18,3	67,2	24,6	6,5	6,5	1,1	M8x1	4	11,5	-20	100	35,1	23,2	1,0	
	EX310G2	110	32	49,2	66,6	22,2	76,2	24,6	8,7	9,9	2	M10x1,25	5	22	-20	100	62,0	37,8	1,9	
55	ES211G2	100	24	32,5	48,4	20,7	74,5	12	8	7,2	1,1	M10x1,25	5	22	-20	100	43,6	29,2	0,9	55
	EX211G2	100	25	55,4	71,3	20,7	74,5	27,7	8	7,2	1,5	M10x1,25	5	22	-20	100	43,6	29,2	1,4	
	EX311G2	120	34	55,6	73	22,2	83	27,8	9	10,6	2	M10x1,25	5	22	-20	100	71,5	44,8	2,3	
60	ES212G2	110	24	33,4	49,3	22,3	82	12	8	8	1,1	M10x1,25	5	22	-20	100	52,5	32,8	1,2	60
	EX212G2	110	27	61,8	77,7	22,3	82	30,9	8	8,2	1,5	M10x1,25	5	22	-20	100	52,5	32,8	1,9	
	EX312G2	130	36	61,9	79,4	23,9	89	31	9	11,3	2	M10x1,25	5	22	-20	100	81,6	51,8	2,9	

*Width across flats (hexagon socket)

CHROME STEEL BEARING INSERTS WITH SPHERICAL OUTER RING

ECCENTRIC LOCKING COLLAR TYPES

Basic version

EX2..G2

ES2..G2

Heavy duty

EX3..G2

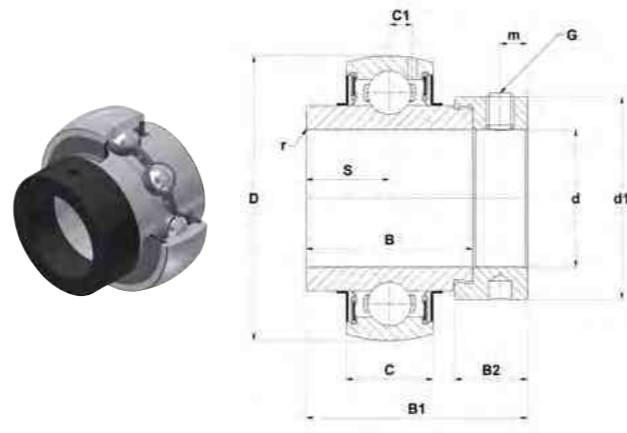

EX..G2

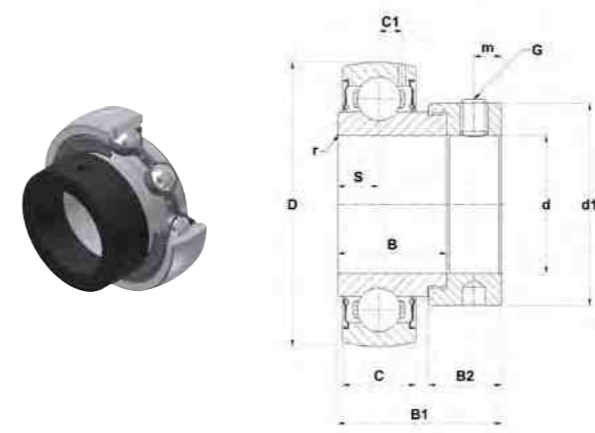

ES..G2

Main dimensions [mm]

d	Bearing insert	D	C	B	B1	B2	d1	S	m	C1	r min	G	SW*	Set screw torque [Nm]	min Temp [°C]	max Temp [°C]	Dynamic load rating C [kN]	Static load rating C0 [kN]	Weight [kg]	d
65	EX213G2	120	28	68,2	85,7	23,5	86	34,1	8,5	8	1,5	M10x1,25	5	22	-20	100	57,2	40,0	2,4	65
	EX313G2	140	38	65,1	85,7	27	97	32,5	11,5	12,1	2	M12x1,25	6	33	-20	100	93,9	60,5	3,7	
70	EX214G2	125	30	68,2	85,7	23,5	96,8	34,1	8,5	9	2	M10x1,25	5	22	-20	100	62,0	45,0	2,6	70
	EX314G2	150	40	68,3	92,1	30,2	102	34,2	12	12,8	2,5	M12x1,25	6	33	-20	100	104,3	68,0	4,5	
75	EX215G2	130	30	74,6	92,1	23,9	102	37,3	8,5	9	2	M10x1,25	5	22	-20	100	66,0	49,5	2,8	75
	EX315G2	160	42	74,6	100	31,8	113	37,3	13	13,5	2,5	M16x1,5	8	64	-20	100	113,4	76,8	5,3	
80	EX216G2	140	33	74,6	95,2	27	110	37,3	10,3	10,3	2	M12x1,25	6	33	-20	100	72,5	54,2	3,1	80
	EX316G2	170	44	81	106,4	31,8	119	40,5	13	14,5	3	M16x1,5	8	64	-20	100	122,9	86,5	6,7	
85	EX217G2	150	35	53,2	73,2	27	119	23,4	10	11	2	M12x1,25	6	33	-20	100	83,2	63,8	3,7	85
	EX317G2	180	46	84,1	109,5	31,8	127	42	13	15,5	3	M16x1,5	8	64	-20	100	132,6	96,5	8,0	
90	EX218G2	160	37	55	72,5	24	120	24,5	9,5	12	2	M12x1,25	6	33	-20	100	96,0	71,5	4,9	90
	EX318G2	190	48	87,3	115,9	36,5	133	43,6	14,5	16,5	3	M20x1,5	10	120	-20	100	143,0	108,0	9,1	
95	EX319G2	200	50	93,7	122,3	36,5	140	46,8	14,5	16,7	3	M20x1,5	10	120	-20	100	156,0	122,0	10,4	95
100	EX320G2	215	54	100	128,6	36,5	146	50	14,5	19	3,5	M20x1,5	10	120	-20	100	171,6	140,0	13,0	100

*Width across flats (hexagon socket)

CHROME STEEL BEARING INSERTS WITH SPHERICAL OUTER RING

ECCENTRIC LOCKING COLLAR TYPES

- Triple lip seal version L3
EX2..G2L3, EX3..G2L3
- Multiple seal system L4
EX2..G2L4
- Agri seal system AGR
EX2..AGR, EX3..AGR

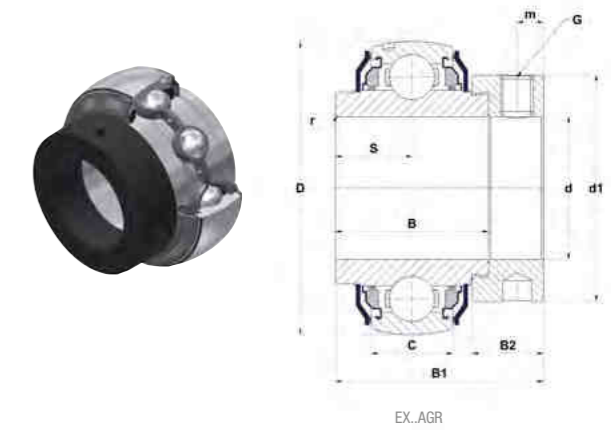
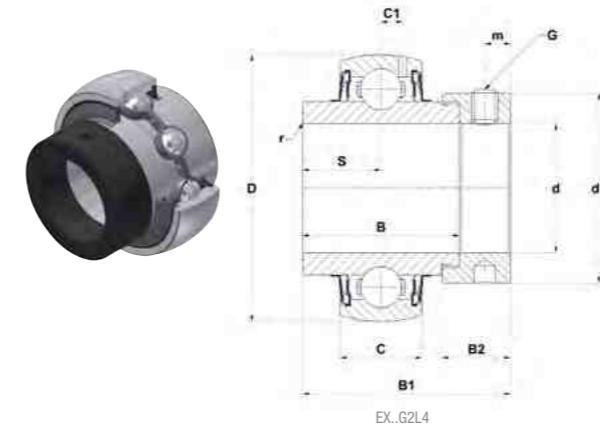
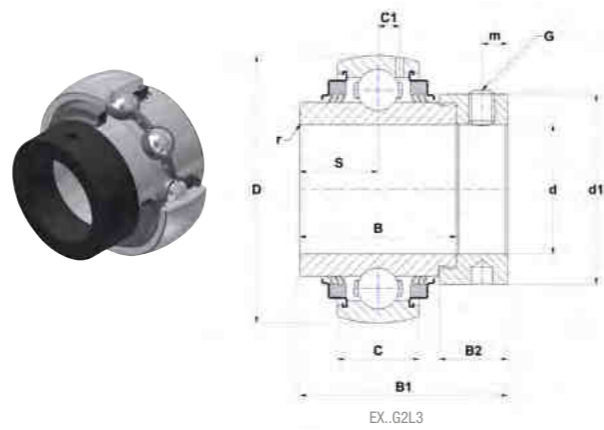

Main dimensions [mm]

d	Bearing insert	D	C	B	B1	B2	d1	S	m	C1	r min	G	SW*	Set screw torque [Nm]	min Temp [°C]	max Temp [°C]	Dynamic load rating C [kN]	Static load rating C0 [kN]	Weight [kg]	d
12	EX201G2L3	47	16	34	43,5	13,5	32,4	17	5	4,4	0,6	M6x1	3	5,5	-20	100	12,8	6,65	0,29	12
	EX201G2L4	47	16	34	43,5	13,5	32,4	17	5	4,4	0,6	M6x1	3	5,5	-20	100	12,8	6,65	0,29	12
15	EX202G2L3	47	16	34	43,5	13,5	32,4	17	5	4,4	0,6	M6x1	3	5,5	-20	100	12,8	6,65	0,27	15
	EX202G2L4	47	16	34	43,5	13,5	32,4	17	5	4,4	0,6	M6x1	3	5,5	-20	100	12,8	6,65	0,27	15
17	EX203G2L3	47	16	34	43,5	13,5	32,4	17	5	4,4	0,6	M6x1	3	5,5	-20	100	12,8	6,65	0,25	17
	EX203G2L4	47	16	34	43,5	13,5	32,4	17	5	4,4	0,6	M6x1	3	5,5	-20	100	12,8	6,65	0,25	17
20	EX204G2L3	47	16	34	43,5	13,5	32,4	17	5	4,4	0,6	M6x1	3	5,5	-20	100	12,8	6,65	0,22	20
	EX204G2L4	47	16	34	43,5	13,5	32,4	17	5	4,4	0,6	M6x1	3	5,5	-20	100	12,8	6,65	0,22	20
25	EX205G2L3	52	17	34,8	44,3	13,5	37,4	17,4	5	4,3	0,6	M6x1	3	5,5	-20	100	14	7,88	0,25	25
	EX205G2L4	52	17	34,8	44,3	13,5	37,4	17,4	5	4,3	0,6	M6x1	3	5,5	-20	100	14	7,88	0,25	25
30	EX206G2L3	62	19	36,4	48,3	15,9	44,1	18,2	6	5	0,6	M8x1	4	11,5	-20	100	19,5	11,2	0,41	30
	EX206G2L4	62	19	36,4	48,3	15,9	44,1	18,2	6	5	0,6	M8x1	4	11,5	-20	100	19,5	11,2	0,41	30
	EX306G2L3	72	24	36,5	50	17,5	50	17,5	6,7	6,5	1,5	M8x1	4	11,5	-20	100	27	15,2	0,68	30
35	EX207AGR	72	20	37,6	51,1	17,5	51,1	18,8	6,5	5,8	1,1	M8x1	4	11,5	-20	100	25,7	15,2	0,64	35
	EX207G2L3	72	20	37,6	51,1	17,5	51,1	18,8	6,5	5,8	1,1	M8x1	4	11,5	-20	100	25,7	15,2	0,6	35
	EX207G2L4	72	20	37,6	51,1	17,5	51,1	18,8	6,5	5,8	1,1	M8x1	4	11,5	-20	100	25,7	15,2	0,6	35
40	EX208AGR	80	21	42,8	56,3	18,3	58	21,4	6,5	6,3	1,1	M8x1	4	11,5	-20	100	29,6	18,2	0,74	40
	EX208G2L3	80	21	42,8	56,3	18,3	58	21,4	6,5	6,3	1,1	M8x1	4	11,5	-20	100	29,6	18,2	0,78	40
	EX208G2L4	80	21	42,8	56,3	18,3	58	21,4	6,5	6,3	1,1	M8x1	4	11,5	-20	100	29,6	18,2	0,78	40
	EX308AGR	90	28	49,5	65,3	20,6	63,5	22,2	8	8,5	2	M10x1,25	5	22	-20	100	40,56	24	1,28	40
	EX308G2L3	90	28	41,3	57,1	20,6	63,5	19,8	8	8,5	2	M10x1,25	5	22	-20	100	40,56	24	1,08	40
45	EX209AGR	85	22	42,8	56,3	18,3	63,5	21,4	6,5	6,8	1,1	M8x1	4	11,5	-20	100	31,85	20,8	0,87	45
	EX209G2L3	85	22	42,8	56,3	18,3	62	21,4	6,5	6,8	1,1	M8x1	4	11,5	-20	100	31,85	20,8	0,87	45
	EX209G2L4	85	22	42,8	56,3	18,3	62	21,4	6,5	6,8	1,1	M8x1	4	11,5	-20	100	31,85	20,8	0,87	45
50	EX210AGR	90	23	49,2	62,7	18,3	67,2	24,6	6,5	6,5	1,1	M8x1	4	11,5	-20	100	35,1	23,2	1,01	50
	EX210G2L3	90	23	49,2	62,7	18,3	67,2	24,6	6,5	6,5	1,1	M8x1	4	11,5	-20	100	35,1	23,2	1,01	50
	EX210G2L4	90	23	49,2	62,7	18,3	67,2	24,6	6,5	6,5	1,1	M8x1	4	11,5	-20	100	35,1	23,2	1,01	50
55	EX211AGR	100	25	55,4	71,3	20,7	74,5	27,7	8	7,2	1,5	M10x1,25	5	22	-20	100	43,55	29,2	1,35	55
	EX211G2L3	100	25	55,4	71,3	20,7	74,5	27,7	8	7,2	1,5	M10x1,25	5	22	-20	100	43,55	29,2	1,39	55
	EX311G2L3	120	34	55,6	73	22,2	83	27,8	9	10,6	2	M10x1,25	5	22	-20	100	71,5	44,8	2,3	55
60	EX212AGR	110	27	61,8	77,7	22,3	82	30,9	8	8,2	1,5	M10x1,25	5	22	-20	100	52,5	32,8	1,67	60
	EX212G2L3	110	27	61,8	77,7	22,3	82	30,9	8	8,2	1,5	M10x1,25	5	22	-20	100	52,5	32,8	1,87	60
65	EX213G2L3	120	28	68,2	85,7	23,5	86	34,1	8,5	8	1,5	M10x1,25	5	22	-20	100	57,2	40	2,41	65
70	EX214G2L3	125	30	68,2	85,7	23,5	96,8	34,1	8,5	9	2	M10x1,25	5	22	-20	100	62	45	2,57	70
75	EX215G2L3	130	30	74,6	92,1	23,9	102	37,3	8,5	9	2	M10x1,25	5	22	-20	100	66	49,5	2,84	75
80	EX216G2L3	140	33	74,6	95,2	27	110	37,3	10,3	10,3	2	M12x1,25	6	33	-20	100	72,5	54,2	3,12	80
85	EX217G2L3	150	35	53,2	73,2	27	119	23,4	10	11	2	M12x1,25	6	33	-20	100	83,2	63,8	3,72	85
90	EX218G2L3	160	37	55	72,5	24	120	24,5	9,5	12	2	M12x1,25	6	33	-20	100	96	71,5	4,9	90

*Width across flats (hexagon socket)

CHROME STEEL BEARING INSERTS WITH SPHERICAL OUTER RING

ECCENTRIC LOCKING COLLAR TYPES

Low temperature version T04

EX2..G2T04

EX3..G2T04

ES2..G2T04

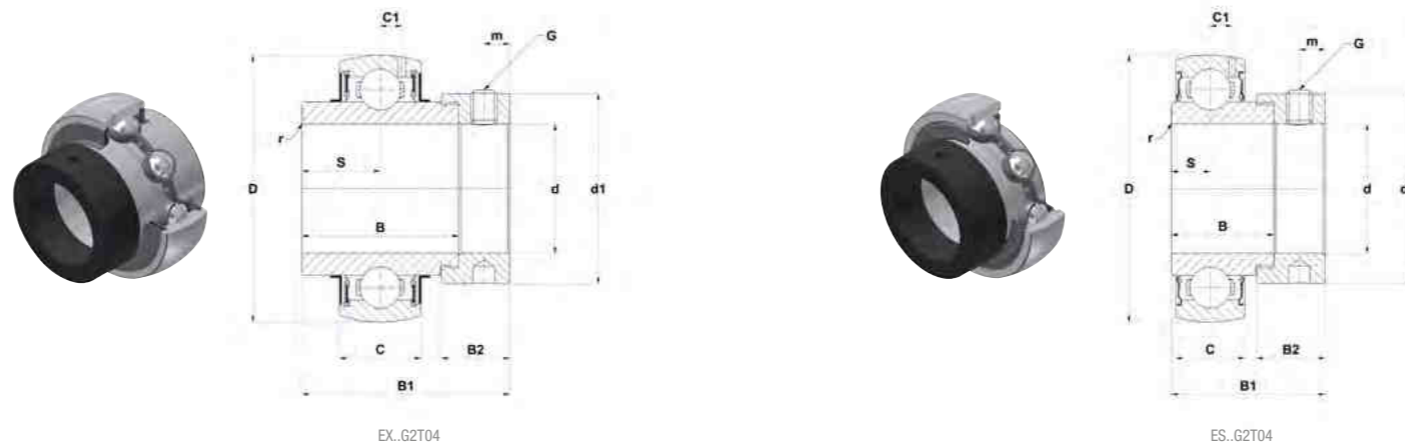

Main dimensions [mm]

d	Bearing insert	D	C	B	B1	B2	d1	S	m	C1	r min	G	SW*	Set screw torque [Nm]	min Temp [°C]	max Temp [°C]	Dynamic load rating C [kN]	Static load rating C0 [kN]	Weight [kg]	d
12	ES201G2T04	40	12	19,1	28,6	13,5	27,2	6,5	5	3,6	0,6	M6x1	3	5,5	-40	100	9,6	4,8	0,1	12
	EX201G2T04	47	16	34	43,5	13,5	32,4	17	5	4,4	0,6	M6x1	3	5,5	-40	100	12,8	6,7	0,3	12
15	ES202G2T04	40	12	19,1	28,6	13,5	27,2	6,5	5	3,6	0,6	M6x1	3	5,5	-40	100	9,6	4,8	0,1	15
	EX202G2T04	47	16	34	43,5	13,5	32,4	17	5	4,4	0,6	M6x1	3	5,5	-40	100	12,8	6,7	0,3	15
17	ES203G2T04	40	12	19,1	28,6	13,5	27,2	6,5	5	3,6	0,6	M6x1	3	5,5	-40	100	9,6	4,8	0,1	17
	EX203G2T04	47	16	34	43,5	13,5	32,4	17	5	4,4	0,6	M6x1	3	5,5	-40	100	12,8	6,7	0,3	17
20	ES204G2T04	47	14	21,4	30,9	13,5	32,4	7,5	5	4	0,6	M6x1	3	5,5	-40	100	12,8	6,7	0,2	20
	EX204G2T04	47	16	34	43,5	13,5	32,4	17	5	4,4	0,6	M6x1	3	5,5	-40	100	12,8	6,7	0,2	20
25	ES205G2T04	52	15	21,4	30,9	13,5	37,4	7,5	5	4,3	0,6	M6x1	3	5,5	-40	100	14,0	7,9	0,2	25
	EX205G2T04	52	17	34,8	44,3	13,5	37,4	17,4	5	4,3	0,6	M6x1	3	5,5	-40	100	14,0	7,9	0,3	25
	EX305G2T04	62	21	34,9	46,8	15,9	42,8	16,7	6	6,2	1,5	M8x1	4	11,5	-40	100	22,4	11,5	0,4	25
30	ES206G2T04	62	16	23,8	35,7	15,9	44,1	9	6	5	0,6	M8x1	4	11,5	-40	100	19,5	11,2	0,3	30
	EX206G2T04	62	19	36,4	48,3	15,9	44,1	18,2	6	5	0,6	M8x1	4	11,5	-40	100	19,5	11,2	0,4	30
	EX306G2T04	72	24	36,5	50	17,5	50	17,5	6,7	6,5	1,5	M8x1	4	11,5	-40	100	27,0	15,2	0,7	30
35	ES207G2T04	72	17	25,4	38,9	17,5	51,1	9,5	6,5	5,7	1,1	M8x1	4	11,5	-40	100	25,7	15,2	0,5	35
	EX207G2T04	72	20	37,6	51,1	17,5	51,1	18,8	6,5	5,8	1,1	M8x1	4	11,5	-40	100	25,7	15,2	0,6	35
	EX307G2T04	80	25	38,1	51,6	17,5	55	18,3	6,7	7,2	2	M8x1	4	11,5	-40	100	33,5	19,2	0,8	35
40	ES208G2T04	80	18	30,2	43,7	18,3	58	11	6,5	6,2	1,1	M8x1	4	11,5	-40	100	29,6	18,2	0,7	40
	EX208G2T04	80	21	42,8	56,3	18,3	58	21,4	6,5	6,3	1,1	M8x1	4	11,5	-40	100	29,6	18,2	0,8	40
	EX308G2T04	90	28	41,3	57,1	20,6	63,5	19,8	8	8,5	2	M10x1,25	5	22	-40	100	40,6	24,0	1,1	40
45	ES209G2T04	85	19	30,2	43,7	18,3	62	11	6,5	6,5	1,1	M8x1	4	11,5	-40	100	31,9	20,8	0,7	45
	EX209G2T04	85	22	42,8	56,3	18,3	62	21,4	6,5	6,8	1,1	M8x1	4	11,5	-40	100	31,9	20,8	0,9	45
	EX309G2T04	100	30	42,9	58,7	20,6	70	19,8	8	9	2	M10x1,25	5	22	-40	100	53,0	31,8	1,5	45
50	ES210G2T04	90	20	30,2	43,7	18,3	67,2	11	6,5	6,5	1,1	M8x1	4	11,5	-40	100	35,1	23,2	0,8	50
	EX210G2T04	90	23	49,2	62,7	18,3	67,2	24,6	6,5	6,5	1,1	M8x1	4	11,5	-40	100	35,1	23,2	1,0	50
	EX310G2T04	110	32	49,2	66,6	22,2	76,2	24,6	8,7	9,9	2	M10x1,25	5	22	-40	100	62,0	37,8	1,9	50
55	ES211G2T04	100	24	32,5	48,4	20,7	74,5	12	8	7,2	1,1	M10x1,25	5	22	-40	100	43,6	29,2	0,9	55
	EX211G2T04	100	25	55,4	71,3	20,7	74,5	27,7	8	7,2	1,5	M10x1,25	5	22	-40	100	43,6	29,2	1,4	55
	EX311G2T04	120	34	55,6	73	22,2	83	27,8	9	10,6	2	M10x1,25	5	22	-40	100	71,5	44,8	2,3	55
60	ES212G2T04	110	24	33,4	49,3	22,3	82	12	8	8	1,1	M10x1,25	5	22	-40	100	52,5	32,8	1,2	60
	EX212G2T04	110	27	61,8	77,7	22,3	82	30,9	8	8,2	1,5	M10x1,25	5	22	-40	100	52,5	32,8	1,9	60
	EX312G2T04	130	36	61,9	79,4	23,9	89	31	9	11,3	2	M10x1,25	5	22	-40	100	81,6	51,8	2,9	60

*Width across flats (hexagon socket)

CHROME STEEL BEARING INSERTS WITH SPHERICAL OUTER RING

ECCENTRIC LOCKING COLLAR TYPES

Low temperature version T04

EX2..G2T04

EX3..G2T04

ES2..G2T04

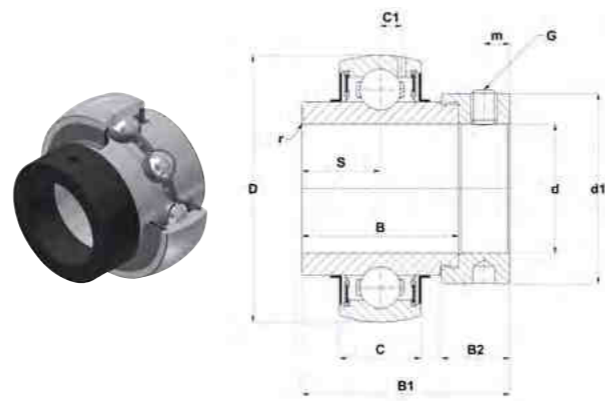

EX..G2T04

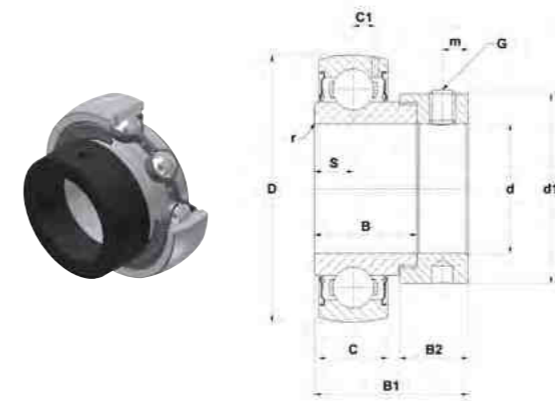

ES..G2T04

Main dimensions [mm]

d	Bearing insert	D	C	B	B1	B2	d1	S	m	C1	r min	G	SW*	Set screw torque [Nm]	min Temp [°C]	max Temp [°C]	Dynamic load rating C [kN]	Static load rating C0 [kN]	Weight [kg]	d
65	EX213G2T04	120	28	68,2	85,7	23,5	86	34,1	8,5	8	1,5	M10x1,25	5	22	-40	100	57,2	40,0	2,4	65
	EX313G2T04	140	38	65,1	85,7	27	97	32,5	11,5	12,1	2	M12x1,25	6	33	-40	100	93,9	60,5	3,7	
70	EX214G2T04	125	30	68,2	85,7	23,5	96,8	34,1	8,5	9	2	M10x1,25	5	22	-40	100	62,0	45,0	2,6	70
	EX314G2T04	150	40	68,3	92,1	30,2	102	34,2	12	12,8	2,5	M12x1,25	6	33	-40	100	104,3	68,0	4,5	
75	EX215G2T04	130	30	74,6	92,1	23,9	102	37,3	8,5	9	2	M10x1,25	5	22	-40	100	66,0	49,5	2,8	75
	EX315G2T04	160	42	74,6	100	31,8	113	37,3	13	13,5	2,5	M16x1,5	8	64	-40	100	113,4	76,8	5,3	
80	EX216G2T04	140	33	74,6	95,2	27	110	37,3	10,3	10,3	2	M12x1,25	6	33	-40	100	72,5	54,2	3,1	80
	EX316G2T04	170	44	81	106,4	31,8	119	40,5	13	14,5	3	M16x1,5	8	64	-40	100	122,9	86,5	6,7	
85	EX217G2T04	150	35	53,2	73,2	27	119	23,4	10	11	2	M12x1,25	6	33	-40	100	83,2	63,8	3,7	85
	EX317G2T04	180	46	84,1	109,5	31,8	127	42	13	15,5	3	M16x1,5	8	64	-40	100	132,6	96,5	8,0	
90	EX218G2T04	160	37	55	72,5	24	120	24,5	9,5	12	2	M12x1,25	6	33	-40	100	96,0	71,5	4,9	90
	EX318G2T04	190	48	87,3	115,9	36,5	133	43,6	14,5	16,5	3	M20x1,5	10	120	-40	100	143,0	108,0	9,1	
95	EX319G2T04	200	50	93,7	122,3	36,5	140	46,8	14,5	16,7	3	M20x1,5	10	120	-40	100	156,0	122,0	10,4	95
100	EX320G2T04	215	54	100	128,6	36,5	146	50	14,5	19	3,5	M20x1,5	10	120	-40	100	171,6	140,0	13,0	100

*Width across flats (hexagon socket)

CHROME STEEL BEARING INSERTS WITH SPHERICAL OUTER RING

ECCENTRIC LOCKING COLLAR TYPES

High temperature version T20

EX2..G2T20

ES2..G2T20

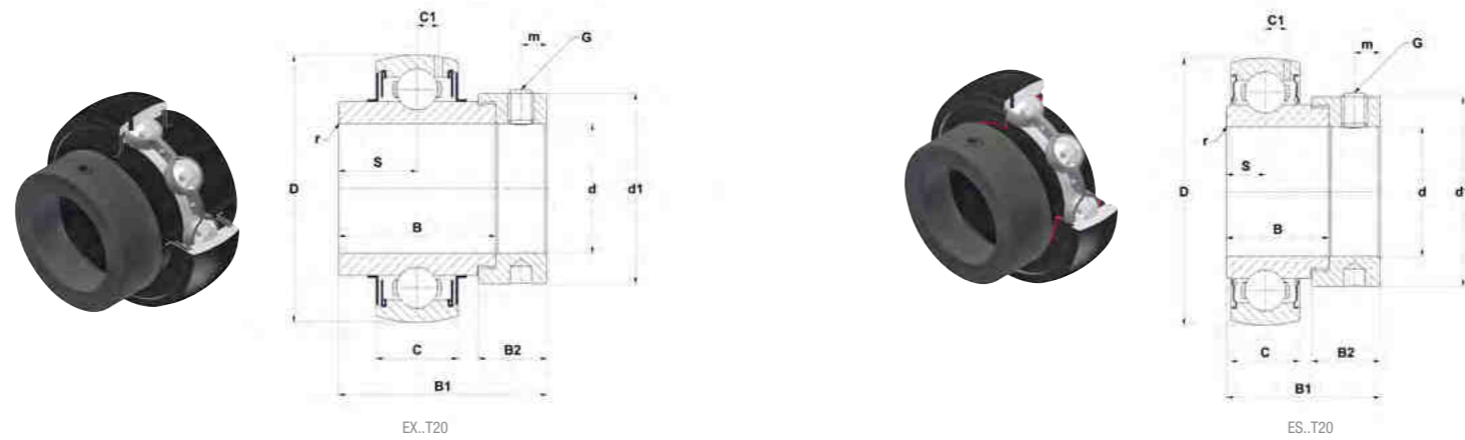

Main dimensions [mm]

d	Bearing insert	D	C	B	B1	B2	d1	S	m	C1	r min	G	SW*	Set screw torque [Nm]	min Temp [°C]	max Temp [°C]	Dynamic load rating C [kN]	Static load rating C0 [kN]	Weight [kg]	d
12	ES201G2T20	40	12	19,1	28,6	13,5	27,2	6,5	5	3,6	0,6	M6x1	3	5,5	-20	200	9,6	4,8	0,1	12
	EX201G2T20	47	16	34	43,5	13,5	32,4	17	5	4,4	0,6	M6x1	3	5,5	-20	200	12,8	6,7	0,3	
15	ES202G2T20	40	12	19,1	28,6	13,5	27,2	6,5	5	3,6	0,6	M6x1	3	5,5	-20	200	9,6	4,8	0,1	15
	EX202G2T20	47	16	34	43,5	13,5	32,4	17	5	4,4	0,6	M6x1	3	5,5	-20	200	12,8	6,7	0,3	
17	ES203G2T20	40	12	19,1	28,6	13,5	27,2	6,5	5	3,6	0,6	M6x1	3	5,5	-20	200	9,6	4,8	0,1	17
	EX203G2T20	47	16	34	43,5	13,5	32,4	17	5	4,4	0,6	M6x1	3	5,5	-20	200	12,8	6,7	0,3	
20	ES204G2T20	47	14	21,4	30,9	13,5	32,4	7,5	5	4	0,6	M6x1	3	5,5	-20	200	12,8	6,7	0,2	20
	EX204G2T20	47	16	34	43,5	13,5	32,4	17	5	4,4	0,6	M6x1	3	5,5	-20	200	12,8	6,7	0,2	
25	ES205G2T20	52	15	21,4	30,9	13,5	37,4	7,5	5	4,3	0,6	M6x1	3	5,5	-20	200	14,0	7,9	0,2	25
	EX205G2T20	52	17	34,8	44,3	13,5	37,4	17,4	5	4,3	0,6	M6x1	3	5,5	-20	200	14,0	7,9	0,3	
30	ES206G2T20	62	16	23,8	35,7	15,9	44,1	9	6	5	0,6	M8x1	4	11,5	-20	200	19,5	11,2	0,3	30
	EX206G2T20	62	19	36,4	48,3	15,9	44,1	18,2	6	5	0,6	M6x1	3	5,5	-20	200	19,5	11,2	0,4	
35	ES207G2T20	72	17	25,4	38,9	17,5	51,1	9,5	6,5	5,7	1,1	M8x1	4	11,5	-20	200	25,7	15,2	0,5	35
	EX207G2T20	72	20	37,6	51,1	17,5	51,1	18,8	6,5	5,8	1,1	M8x1	4	11,5	-20	200	25,7	15,2	0,6	
40	ES208G2T20	80	18	30,2	43,7	18,3	58	11	6,5	6,2	1,1	M8x1	4	11,5	-20	200	29,6	18,2	0,7	40
	EX208G2T20	80	21	42,8	56,3	18,3	60,3	21,4	6,5	6,3	1,1	M8x1	4	11,5	-20	200	29,6	18,2	0,8	
45	ES209G2T20	85	19	30,2	43,7	18,3	62	11	6,5	6,5	1,1	M8x1	4	11,5	-20	200	31,9	20,8	0,7	45
	EX209G2T20	85	22	42,8	56,3	18,3	62	21,4	6,5	6,8	1,1	M8x1	4	11,5	-20	200	31,9	20,8	0,9	
50	ES210G2T20	90	20	30,2	43,7	18,3	67,2	11	6,5	6,5	1,1	M8x1	4	11,5	-20	200	35,1	23,2	0,8	50
	EX210G2T20	90	23	49,2	62,7	18,3	67,2	24,6	6,5	6,5	1,1	M8x1	4	11,5	-20	200	35,1	23,2	1,0	
55	ES211G2T20	100	24	32,5	48,4	20,7	74,5	12	8	7,2	1,1	M10x1,25	5	22	-20	200	43,6	29,2	0,9	55
	EX211G2T20	100	25	55,4	71,3	20,7	74,5	27,7	8	7,2	1,5	M10x1,25	5	22	-20	200	43,6	29,2	1,4	
60	ES212G2T20	110	24	33,4	49,3	22,3	82	12	8	8	1,1	M10x1,25	5	22	-20	200	52,5	32,8	1,2	60
	EX212G2T20	110	27	61,8	77,7	22,3	82	30,9	8	8,2	1,5	M10x1,25	5	22	-20	200	52,5	32,8	1,9	
65	EX213G2T20	120	28	68,2	85,7	23,5	86	34,1	8,5	8	1,5	M10x1,25	5	22	-20	200	57,2	40,0	2,4	65
70	EX214G2T20	125	30	68,2	85,7	23,5	96,8	34,1	8,5	9	2	M10x1,25	5	22	-20	200	62,0	45,0	2,6	70
75	EX215G2T20	130	30	74,6	92,1	23,9	102	37,3	8,5	9	2	M10x1,25	5	22	-20	200	66,0	49,5	2,8	75
80	EX216G2T20	140	33	74,6	95,2	27	110	37,3	10,3	10,3	2	M12x1,25	6	33	-20	200	72,5	54,2	3,1	80
85	EX217G2T20	150	35	53,2	73,2	27	119	23,4	10	11	2	M12x1,25	6	33	-20	200	83,2	63,8	3,7	85
90	EX218G2T20	160	37	55	72,5	24	120	24,5	9,5	12	2	M12x1,25	6	33	-20	200	96,0	71,5	4,9	90

*Width across flats (hexagon socket)

CHROME STEEL BEARING INSERTS WITH SPHERICAL OUTER RING

ECCENTRIC LOCKING COLLAR TYPES

For use with protective caps PCC / PCO

ES2..G1N

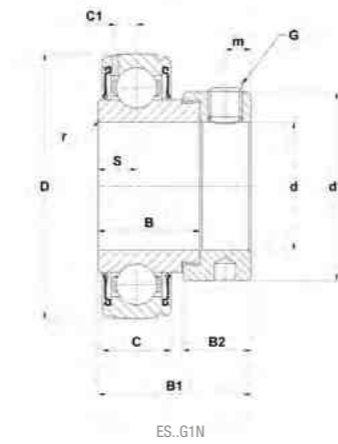

Main dimensions [mm]

d	Bearing insert	D	C	B	B1	B2	d1	S	m	C1	r min	G	SW*	Set screw torque [Nm]	min Temp [°C]	max Temp [°C]	Dynamic load rating C [kN]	Static load rating C0 [kN]	Weight [kg]	d
17	ES203G1N	40	12	19,1	28,6	13,5	27,2	6,5	5	3,6	0,6	M6x1	3	5,5	-20	100	9,6	4,8	0,1	17
20	ES204G1N	47	14	21,4	30,9	13,5	32,4	7,5	5	4	0,6	M6x1	3	5,5	-20	100	12,8	6,7	0,2	20
25	ES205G1N	52	15	21,4	30,9	13,5	37,4	7,5	5	4,3	0,6	M6x1	3	5,5	-20	100	14,0	7,9	0,2	25
30	ES206G1N	62	16	23,8	35,7	15,9	44,1	9	6	5	0,6	M8x1	4	11,5	-20	100	19,5	11,2	0,3	30
35	ES207G1N	72	17	25,4	38,9	17,5	51,1	9,5	6,5	5,7	1,1	M8x1	4	11,5	-20	100	25,7	15,2	0,5	35
40	ES208G1N	80	18	30,2	43,7	18,3	58	11	6,5	6,2	1,1	M8x1	4	11,5	-20	100	29,6	18,2	0,7	40
45	ES209G1N	85	19	30,2	43,7	18,3	62	11	6,5	6,5	1,1	M8x1	4	11,5	-20	100	31,9	20,8	0,7	45

*Width across flats (hexagon socket)

CHROME STEEL BEARING INSERTS WITH SPHERICAL OUTER RING

SET SCREW TYPES

Basic version

UC2..G2

US2..G2

Medium duty

UCX..G2

Heavy duty

UC3..G2

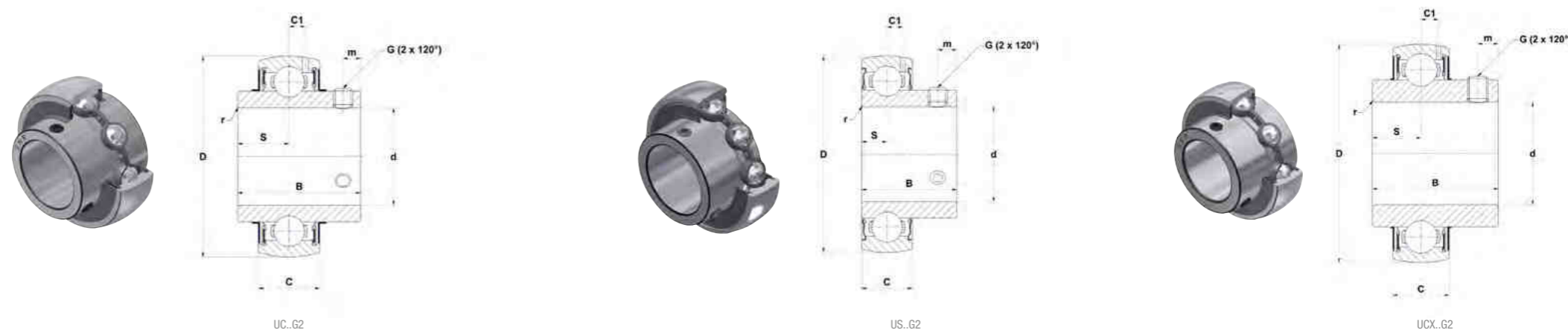

Main dimensions [mm]

d	Bearing insert	D	C	B	S	m	C1	r min	G	SW*	Set screw torque [Nm]	min Temp [°C]	max Temp [°C]	Dynamic load rating C [kN]	Static load rating C0 [kN]	Weight [kg]	d
12	UC201G2	47	16	31	12,7	4,7	4,4	0,6	M6x1	3	5,5	-20	100	12,8	6,7	0,2	12
	US201G2	40	12	22	6	4	3,6	0,6	M5x0,8	2,5	3,5	-20	100	9,6	4,8	0,1	
15	UC202G2	47	16	31	12,7	4,7	4,4	0,6	M6x1	3	5,5	-20	100	12,8	6,7	0,2	15
	US202G2	40	12	22	6	4	3,6	0,6	M5x0,8	2,5	3,5	-20	100	9,6	4,8	0,1	
17	UC203G2	47	16	31	12,7	4,7	4,4	0,6	M6x1	3	5,5	-20	100	12,8	6,7	0,2	17
	US203G2	40	12	22	6	4	3,6	0,6	M5x0,8	2,5	3,5	-20	100	9,6	4,8	0,1	
20	UC204G2	47	16	31	12,7	4,7	4,4	0,6	M6x1	3	5,5	-20	100	12,8	6,7	0,2	20
	US204G2	47	14	25	7	5	4	0,6	M6x1	3	5,5	-20	100	12,8	6,7	0,1	
25	UC205G2	52	17	34	14,3	5,5	4,3	0,6	M6x1	3	5,5	-20	100	14,0	7,9	0,2	25
	UC305G2	62	21	38	15	6	6,2	1,5	M6x1	3	5,5	-20	100	22,4	11,5	0,4	
	US205G2	52	15	27	7,5	5,5	4,3	0,6	M6x1	3	5,5	-20	100	14,0	7,9	0,2	
30	UC206G2	62	19	38,1	15,9	5,5	5	0,6	M6x1	3	5,5	-20	100	19,5	11,2	0,3	30
	UC306G2	72	24	43	17	6	6,5	1,5	M6x1	3	5,5	-20	100	27,0	15,2	0,6	
	US206G2	62	16	30	8	6	5	0,6	M6x1	3	5,5	-20	100	19,5	11,2	0,3	
35	UC207G2	72	20	42,9	17,5	6,5	5,8	1,1	M8x1	4	11,5	-20	100	25,7	15,2	0,5	35
	UC307G2	80	25	48	19	8	7,2	2	M8x1	4	11,5	-20	100	33,5	19,2	0,7	
	UCX07G2	80	21	49,2	19	8	6,3	1,2	M8x1	4	11,5	-20	100	29,6	18,2	0,8	
	US207G2	72	17	32	8,5	6,5	5,7	0,6	M6x1	3	5,5	-20	100	25,7	15,2	0,4	
40	UC208G2	80	21	49,2	19	8	6,3	1,1	M8x1	4	11,5	-20	100	29,6	18,2	0,6	40
	UC308G2	90	28	52	19	10	8,5	2	M10x1,25	5	22	-20	100	40,6	24,0	1,0	
	UCX08G2	85	22	49,2	19	8	6,8	1,2	M8x1	4	11,5	-20	100	31,9	20,8	0,8	
	US208G2	80	18	34	9	7	6,2	1,1	M8x1	4	11,5	-20	100	29,6	18,2	0,6	
45	UC209G2	85	22	49,2	19	8	6,8	1,1	M8x1	4	11,5	-20	100	31,9	20,8	0,7	45
	UC309G2	100	30	57	22	10	9	2	M10x1,25	5	22	-20	100	53,0	31,8	1,3	
	UCX09G2	90	23	51,6	19	9	6,5	1,2	M10x1,25	5	22	-20	100	35,1	23,2	1,0	
	US209G2	85	19	41,2	10,2	8,2	6,5	1,1	M8x1	4	11,5	-20	100	31,9	20,8	0,7	
50	UC210G2	90	23	51,6	19	9	6,5	1,1	M10x1,25	5	22	-20	100	35,1	23,2	0,8	50
	UC310G2	110	32	61	22	12	9,9	2	M12x1,25	6	33	-20	100	62,0	37,8	1,7	
	UCX10G2	100	25	55,6	22,2	9	7,2	1,2	M10x1,25	5	22	-20	100	43,6	29,2	1,3	
	US210G2	90	20	43,5	10,9	9,2	6,5	1,1	M8x1	4	11,5	-20	100	35,1	23,2	0,8	
55	UC211G2	100	25	55,6	22,2	9	7,2	1,1	M10x1,25	5	22	-20	100	43,6	29,2	1,1	55
	UC311G2	120	34	66	25	12	10,6	2	M12x1,25	6	33	-20	100	71,5	44,8	1,9	
	UCX11G2	110	27	65,1	25,4	10,5	8,2	2	M10x1,25	5	22	-20	100	52,5	32,8	1,7	
	US211G2	100	23	45,3	11,8	9,8	7,2	1,1	M10x1,25	5	22	-20	100	43,6	29,2	1,1	

*Width across flats (hexagon socket)

CHROME STEEL BEARING INSERTS WITH SPHERICAL OUTER RING

SET SCREW TYPES

Basic version

UC2..G2

US2..G2

Medium duty

UCX..G2

Heavy duty

UC3..G2

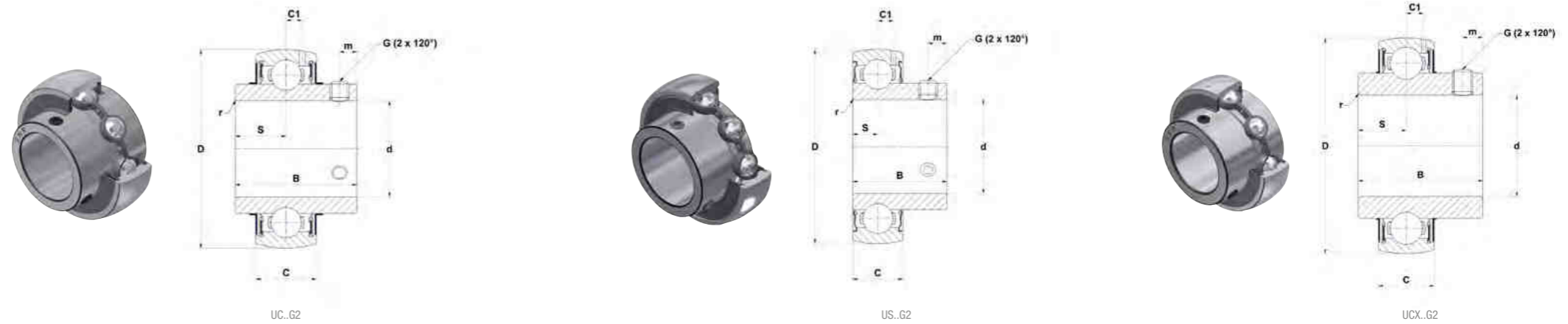

Main dimensions [mm]

d	Bearing insert	D	C	B	S	m	C1	r min	G	SW*	Set screw torque [Nm]	min Temp [°C]	max Temp [°C]	Dynamic load rating C [kN]	Static load rating C0 [kN]	Weight [kg]	d
60	UC212G2	110	27	65,1	25,4	10,5	8,2	1,1	M10x1,25	5	22	-20	100	52,5	32,8	1,5	60
	UC312G2	130	36	71	26	12	11,3	2	M12x1,25	6	33	-20	100	81,6	51,8	2,6	
	UCX12G2	125	30	74,6	30,2	12	9	2	M12x1,25	6	33	-20	100	62,0	45,0	2,7	
	US212G2	110	24	53,7	14,9	9,8	8	1,1	M10x1,25	5	22	-20	100	52,5	32,8	1,3	
65	UC213G2	120	28	65,1	25,4	12	8	1,5	M12x1,25	6	33	-20	100	57,2	40,0	1,9	65
	UC313G2	140	38	75	30	12	12,1	2	M12x1,25	6	33	-20	100	93,9	60,5	3,3	
	UCX13G2	130	30	77,8	33,3	12	9	2	M12x1,25	6	33	-20	100	66,0	49,5	2,9	
70	UC214G2	125	30	74,6	30,2	12	9	2	M12x1,25	6	33	-20	100	62,0	45,0	2,1	70
	UC314G2	150	40	78	33	12	12,8	2,5	M12x1,25	6	33	-20	100	104,3	68,0	4,0	
	UCX14G2	130	30	77,8	33,3	12	9	2	M12x1,25	6	33	-20	100	66,0	49,5	2,6	
75	UC215G2	130	30	77,8	33,3	12	9	2	M12x1,25	6	33	-20	100	66,0	49,5	2,2	75
	UC315G2	160	42	82	32	14	13,5	2,5	M14x1,5	6	42	-20	100	113,4	76,8	4,3	
	UCX15G2	140	33	82,6	33,3	14	10,3	2,5	M12x1,25	6	33	-20	100	72,5	54,2	3,2	
80	UC216G2	140	33	82,6	33,3	14	10,3	2	M12x1,25	6	33	-20	100	72,5	54,2	2,8	80
	UC316G2	170	44	86	34	14	14,5	3	M14x1,5	6	42	-20	100	122,9	86,5	5,6	
	UCX16G2	150	35	85,7	34,1	14	11	2,5	M12x1,25	6	33	-20	100	83,2	63,8	4,0	
85	UC217G2	150	35	85,7	34,1	14	11	2	M12x1,25	6	33	-20	100	83,2	63,8	3,4	85
	UC317G2	180	46	96	40	16	15,5	3	M16x1,5	8	64	-20	100	132,6	96,5	6,8	
90	UC218G2	160	37	96	39,7	14	12	2	M12x1,25	6	33	-20	100	96,0	71,5	4,5	90
	UC318G2	190	48	96	40	16	16,5	3,5	M16x1,5	8	64	-20	100	143,0	108,0	7,9	
95	UC319G2	200	50	103	41	18	16,7	3	M16x1,5	8	64	-20	100	156,0	122,0	8,9	95
100	UC320G2	215	54	108	42	18	19	3,5	M18x1,5	9	75	-20	100	171,6	140,0	11,2	100
105	UC321G2	225	56	112	44	18	20	3	M18x1,5	9	75	-20	100	182,0	155,0	12,2	105
110	UC322G2	240	60	117	46	18	21	3	M18x1,5	9	75	-20	100	205,0	178,0	14,3	110
120	UC324G2	260	64	126	51	18	22	3	M18x1,5	9	75	-20	100	228,0	208,0	18,5	120
130	UC326G2	280	68	135	54	20	23	4	M20x1,5	10	120	-20	100	252,0	242,0	23,0	130
140	UC328G2	300	73	145	59	20	25	4	M20x1,5	10	120	-20	100	275,0	272,0	28,5	140

*Width across flats (hexagon socket)

CHROME STEEL BEARING INSERTS WITH SPHERICAL OUTER RING

SET SCREW TYPES

Triple lip seal version L3
UC2..G2L3, UC3..G2L3

Multiple seal system L4
UC2..G2L4

Agri seal system AGR
**UC2..AGR
 UC3..AGR**

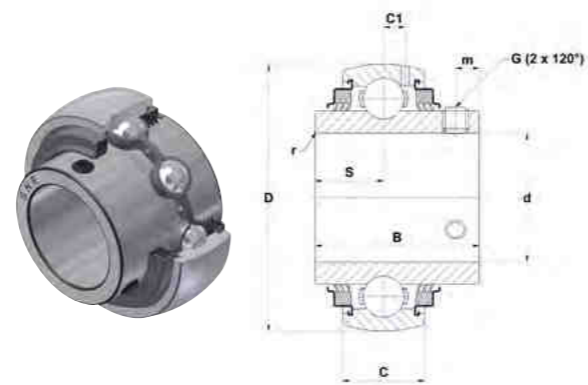

UC..G2L3

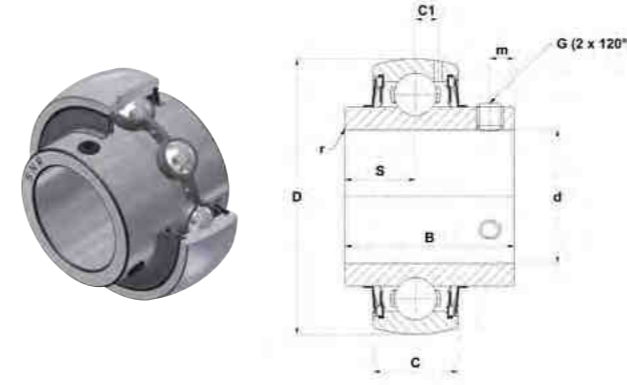

UC..G2L4

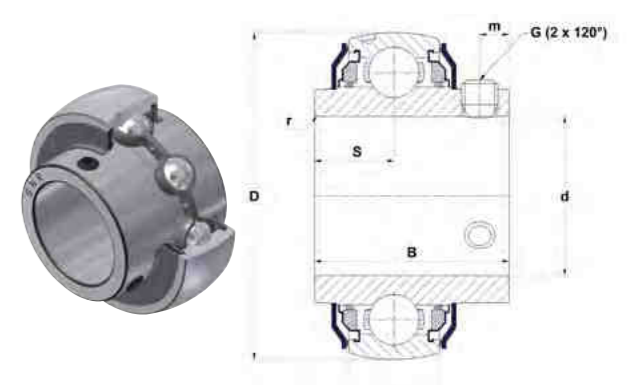

UC..AGR

Main dimensions [mm]

d	Bearing insert	D	C	B	S	m	C1	r min	G	SW*	Set screw torque [Nm]	min Temp [°C]	max Temp [°C]	Dynamic load rating C [kN]	Static load rating C0 [kN]	Weight [kg]	d
12	UC201G2L3	47	16	31	12,7	4,7	4,4	0,6	M6x1	3	5,5	-20	100	12,8	6,7	0,2	12
	UC201G2L4	47	16	31	12,7	4,7	4,4	0,6	M6x1	3	5,5	-20	100	12,8	6,7	0,2	12
15	UC202G2L3	47	16	31	12,7	4,7	4,4	0,6	M6x1	3	5,5	-20	100	12,8	6,7	0,2	15
	UC202G2L4	47	16	31	12,7	4,7	4,4	0,6	M6x1	3	5,5	-20	100	12,8	6,7	0,2	15
17	UC203G2L3	47	16	31	12,7	4,7	4,4	0,6	M6x1	3	5,5	-20	100	12,8	6,7	0,2	17
	UC203G2L4	47	16	31	12,7	4,7	4,4	0,6	M6x1	3	5,5	-20	100	12,8	6,7	0,2	17
20	UC204G2L3	47	16	31	12,7	4,7	4,4	0,6	M6x1	3	5,5	-20	100	12,8	6,7	0,2	20
	UC204G2L4	47	16	31	12,7	4,7	4,4	0,6	M6x1	3	5,5	-20	100	12,8	6,7	0,2	20
25	UC205G2L3	52	17	34	14,3	5,5	4,3	0,6	M6x1	3	5,5	-20	100	14,0	7,9	0,2	25
	UC205G2L4	52	17	34	14,3	5,5	4,3	0,6	M6x1	3	5,5	-20	100	14,0	7,9	0,2	25
30	UC206AGR	62	19	39	15,9	5,5	5	0,6	M6x1	3	3,7	-20	100	19,5	11,2	0,3	30
	UC206G2L3	62	19	38,1	15,9	5,5	5	0,6	M6x1	3	5,5	-20	100	19,5	11,2	0,3	30
	UC206G2L4	62	19	38,1	15,9	5,5	5	0,6	M6x1	3	5,5	-20	100	19,5	11,2	0,3	30
35	UC207AGR	72	20	42,9	17,5	6,5	5,8	1,1	M8x1	4	11,5	-20	100	25,7	15,2	0,5	35
	UC207G2L3	72	20	42,9	17,5	6,5	5,8	1,1	M8x1	4	11,5	-20	100	25,7	15,2	0,5	35
	UC207G2L4	72	20	42,9	17,5	6,5	5,8	1,1	M8x1	4	11,5	-20	100	25,7	15,2	0,5	35
40	UC208AGR	80	21	49,2	19	8	6,3	1,1	M8x1	4	11,5	-20	100	29,6	18,2	0,7	40
	UC208G2L3	80	21	49,2	19	8	6,3	1,1	M8x1	4	11,5	-20	100	29,6	18,2	0,6	40
	UC208G2L4	80	21	49,2	19	8	6,3	1,1	M8x1	4	11,5	-20	100	29,6	18,2	0,6	40
	UC308AGR	90	28	58	22,2	8,5	8,5	2	M10x1,25	5	22	-20	100	40,6	24,0	1,1	40
	UC308G2L3	90	28	52	19	10	8,5	2	M10x1,25	5	22	-20	100	40,6	24,0	1,0	40
45	UC209AGR	85	22	49,2	19	8	6,8	1,1	M8x1	4	11,5	-20	100	31,9	20,8	0,7	45
	UC209G2L3	85	22	49,2	19	8	6,8	1,1	M8x1	4	11,5	-20	100	31,9	20,8	0,7	45
	UC209G2L4	85	22	49,2	19	8	6,8	1,1	M8x1	4	11,5	-20	100	31,9	20,8	0,7	45
	UC309AGR	100	30	57	22	9	9	2	M10x1,25	5	22	-20	100	53,0	31,8	1,3	45
50	UC210AGR	90	23	51,6	19	9	6,5	1,1	M8x1	4	11,5	-20	100	35,1	23,2	0,8	50
	UC210G2L3	90	23	51,6	19	9	6,5	1,1	M10x1,25	5	22	-20	100	35,1	23,2	0,8	50
	UC210G2L4	90	23	51,6	19	9	6,5	1,1	M10x1,25	5	22	-20	100	35,1	23,2	0,8	50
55	UC211AGR	100	25	55,6	22,2	9	7,2	1,5	M8x1	4	11,5	-20	100	43,6	29,2	1,1	55
	UC211G2L3	100	25	55,6	22,2	9	7,2	1,1	M10x1,25	5	22	-20	100	43,6	29,2	1,1	55
60	UC212AGR	110	27	65,1	25,4	10,5	8,2	1,5	M10x1,25	5	22	-20	100	52,5	32,8	1,4	60
	UC212G2L3	110	27	65,1	25,4	10,5	8,2	1,1	M10x1,25	5	22	-20	100	52,5	32,8	1,5	60
	UC312G2L3	130	36	71	26	12	11,3	2	M12x1,25	6	33	-20	100	81,6	51,8	2,6	60
65	UC213G2L3	120	28	65,1	25,4	12	8	1,5	M12x1,25	6	33	-20	100	57,2	40,0	1,9	65
70	UC214G2L3	125	30	74,6	30,2	12	9	2	M12x1,25	6	33	-20	100	62,0	45,0	2,1	70
75	UC215G2L3	130	30	77,8	33,3	12	9	2	M12x1,25	6	33	-20	100	66,0	49,5	2,2	75
80	UC216G2L3	140	33	82,6	33,3	14	10,3	2	M12x1,25	6	33	-20	100	72,5	54,2	2,8	80
85	UC217G2L3	150	35	85,7	34,1	14	11	2	M12x1,25	6	33	-20	100	83,2	63,8	3,4	85
90	UC218G2L3	160	37	96	39,7	14	12	2	M12x1,25	6	33	-20	100	96,0	71,5	4,5	90

*Width across flats (hexagon socket)

CHROME STEEL BEARING INSERTS WITH SPHERICAL OUTER RING

SET SCREW TYPES

Low temperature version T04

UC2..G2T04

UC3..G2T04

US2..G2T04

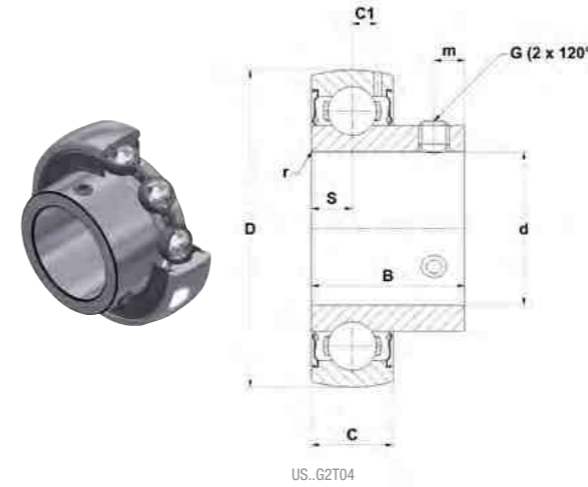
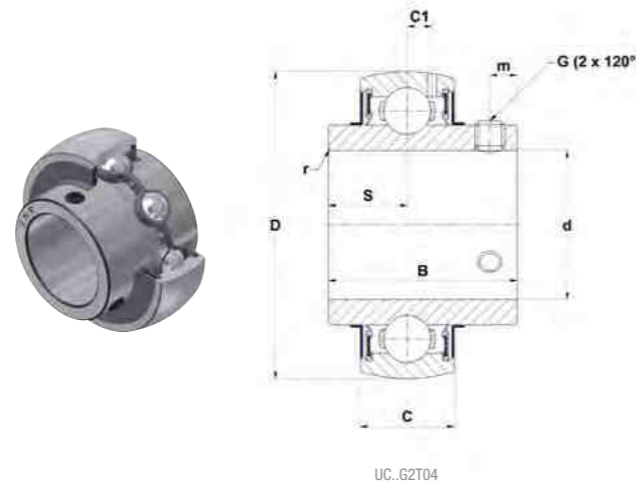

Main dimensions [mm]

d	Bearing insert	D	C	B	S	m	C1	r min	G	SW*	Set screw torque [Nm]	min Temp [°C]	max Temp [°C]	Dynamic load rating C [kN]	Static load rating C0 [kN]	Weight [kg]	d
12	UC201G2T04	47	16	31	12,7	4,7	4,4	0,6	M6x1	3	5,5	-40	100	12,8	6,7	0,2	12
	US201G2T04	40	12	22	6	4	3,6	0,6	M5x0,8	2,5	3,5	-40	100	9,6	4,8	0,1	
15	UC202G2T04	47	16	31	12,7	4,7	4,4	0,6	M6x1	3	5,5	-40	100	12,8	6,7	0,2	15
	US202G2T04	40	12	22	6	4	3,6	0,6	M5x0,8	2,5	3,5	-40	100	9,6	4,8	0,1	
17	UC203G2T04	47	16	31	12,7	4,7	4,4	0,6	M6x1	3	5,5	-40	100	12,8	6,7	0,2	17
	US203G2T04	40	12	22	6	4	3,6	0,6	M5x0,8	2,5	3,5	-40	100	9,6	4,8	0,1	
20	UC204G2T04	47	16	31	12,7	4,7	4,4	0,6	M6x1	3	5,5	-40	100	12,8	6,7	0,2	20
	US204G2T04	47	14	25	7	5	4	0,6	M6x1	3	5,5	-40	100	12,8	6,7	0,1	
25	UC205G2T04	52	17	34	14,3	5,5	4,3	0,6	M6x1	3	5,5	-40	100	14,0	7,9	0,2	25
	UC305G2T04	62	21	38	15	6	6,2	1,5	M6x1	3	5,5	-40	100	22,4	11,5	0,4	
	US205G2T04	52	15	27	7,5	5,5	4,3	0,6	M6x1	3	5,5	-40	100	14,0	7,9	0,2	
30	UC206G2T04	62	19	38,1	15,9	5,5	5	0,6	M6x1	3	5,5	-40	100	19,5	11,2	0,3	30
	UC306G2T04	72	24	43	17	6	6,5	1,5	M6x1	3	5,5	-40	100	27,0	15,2	0,6	
	US206G2T04	62	16	30	8	6	5	0,6	M6x1	3	5,5	-40	100	19,5	11,2	0,3	
35	UC207G2T04	72	20	42,9	17,5	6,5	5,8	1,1	M8x1	4	11,5	-40	100	25,7	15,2	0,5	35
	UC307G2T04	80	25	48	19	8	7,2	2	M8x1	4	11,5	-40	100	33,5	19,2	0,7	
	US207G2T04	72	17	32	8,5	6,5	5,7	0,6	M6x1	3	5,5	-40	100	25,7	15,2	0,4	
40	UC208G2T04	80	21	49,2	19	8	6,3	1,1	M8x1	4	11,5	-40	100	29,6	18,2	0,6	40
	UC308G2T04	90	28	52	19	10	8,5	2	M10x1,25	5	22	-40	100	40,6	24,0	1,0	
	US208G2T04	80	18	34	9	7	6,2	1,1	M8x1	4	11,5	-40	100	29,6	18,2	0,6	
45	UC209G2T04	85	22	49,2	19	8	6,8	1,1	M8x1	4	11,5	-40	100	31,9	20,8	0,7	45
	UC309G2T04	100	30	57	22	10	9	2	M10x1,25	5	22	-40	100	53,0	31,8	1,3	
	US209G2T04	85	19	41,2	10,2	8,2	6,5	1,1	M8x1	4	11,5	-40	100	31,9	20,8	0,7	
50	UC210G2T04	90	23	51,6	19	9	6,5	1,1	M10x1,25	5	22	-40	100	35,1	23,2	0,8	50
	UC310G2T04	110	32	61	22	12	9,9	2	M12x1,25	6	33	-40	100	62,0	37,8	1,7	
	US210G2T04	90	20	43,5	10,9	9,2	6,5	1,1	M8x1	4	11,5	-40	100	35,1	23,2	0,8	
55	UC211G2T04	100	25	55,6	22,2	9	7,2	1,1	M10x1,25	5	22	-40	100	43,6	29,2	1,1	55
	UC311G2T04	120	34	66	25	12	10,6	2	M12x1,25	6	33	-40	100	71,5	44,8	1,9	
	US211G2T04	100	23	45,3	11,8	9,8	7,2	1,1	M10x1,25	5	22	-40	100	43,6	29,2	1,1	
60	UC212G2T04	110	27	65,1	25,4	10,5	8,2	1,1	M10x1,25	5	22	-40	100	52,5	32,8	1,5	60
	UC312G2T04	130	36	71	26	12	11,3	2	M12x1,25	6	33	-40	100	81,6	51,8	2,6	
	US212G2T04	110	24	53,7	14,9	9,8	8	1,1	M10x1,25	5	22	-40	100	52,5	32,8	1,3	

*Width across flats (hexagon socket)

CHROME STEEL BEARING INSERTS WITH SPHERICAL OUTER RING

SET SCREW TYPES

Low temperature version T04

UC2..G2T04

UC3..G2T04

US2..G2T04

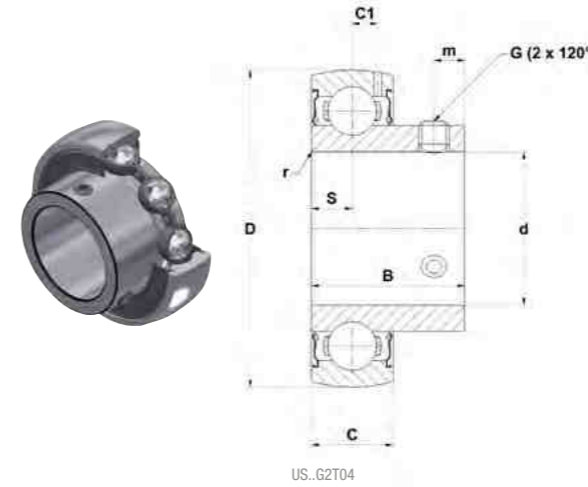
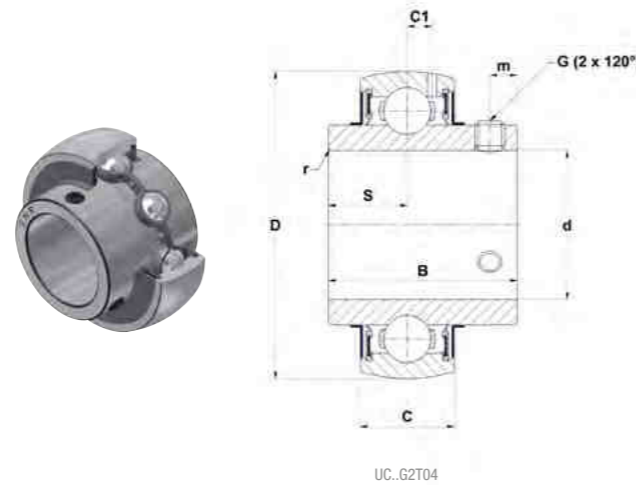

Main dimensions [mm]

d	Bearing insert	D	C	B	S	m	C1	r min	G	SW*	Set screw torque [Nm]	min Temp [°C]	max Temp [°C]	Dynamic load rating C [kN]	Static load rating C0 [kN]	Weight [kg]	d
65	UC213G2T04	120	28	65,1	25,4	12	8	1,5	M12x1,25	6	33	-40	100	57,2	40,0	1,9	65
	UC313G2T04	140	38	75	30	12	12,1	2	M12x1,25	6	33	-40	100	93,9	60,5	3,3	65
70	UC214G2T04	125	30	74,6	30,2	12	9	2	M12x1,25	6	33	-40	100	62,0	45,0	2,1	70
	UC314G2T04	150	40	78	33	12	12,8	2,5	M12x1,25	6	33	-40	100	104,3	68,0	4,0	70
75	UC215G2T04	130	30	77,8	33,3	12	9	2	M12x1,25	6	33	-40	100	66,0	49,5	2,2	75
	UC315G2T04	160	42	82	32	14	13,5	2,5	M14x1,5	6	42	-40	100	113,4	76,8	4,3	75
80	UC216G2T04	140	33	82,6	33,3	14	10,3	2	M12x1,25	6	33	-40	100	72,5	54,2	2,8	80
	UC316G2T04	170	44	86	34	14	14,5	3	M14x1,5	6	42	-40	100	122,9	86,5	5,6	80
85	UC217G2T04	150	35	85,7	34,1	14	11	2	M12x1,25	6	33	-40	100	83,2	63,8	3,4	85
	UC317G2T04	180	46	96	40	16	15,5	3	M16x1,5	8	64	-40	100	132,6	96,5	6,8	85
90	UC218G2T04	160	37	96	39,7	14	12	2	M12x1,25	6	33	-40	100	96,0	71,5	4,5	90
	UC318G2T04	190	48	96	40	16	16,5	3,5	M16x1,5	8	64	-40	100	143,0	108,0	7,9	90
95	UC319G2T04	200	50	103	41	18	16,7	3	M16x1,5	8	64	-40	100	156,0	122,0	8,9	95
100	UC320G2T04	215	54	108	42	18	19	3,5	M18x1,5	9	75	-40	100	171,6	140,0	11,2	100
105	UC321G2T04	225	57	112	44	18	20	3	M18x1,5	9	75	-40	100	182,0	155,0	12,2	105
110	UC322G2T04	240	60	117	46	18	21	3	M18x1,5	9	75	-40	100	205,0	178,0	14,3	110
120	UC324G2T04	260	64	126	51	18	22	3	M18x1,5	9	75	-40	100	228,0	208,0	18,5	120
130	UC326G2T04	280	68	135	54	20	23	4	M20x1,5	10	120	-40	100	252,0	242,0	23,0	130
140	UC328G2T04	300	73	145	59	20	25	4	M20x1,5	10	120	-40	100	275,0	272,0	28,5	140

*Width across flats (hexagon socket)

CHROME STEEL BEARING INSERTS WITH SPHERICAL OUTER RING

SET SCREW TYPES

High temperature version T20

UC2..G2T20

US2..G2T20

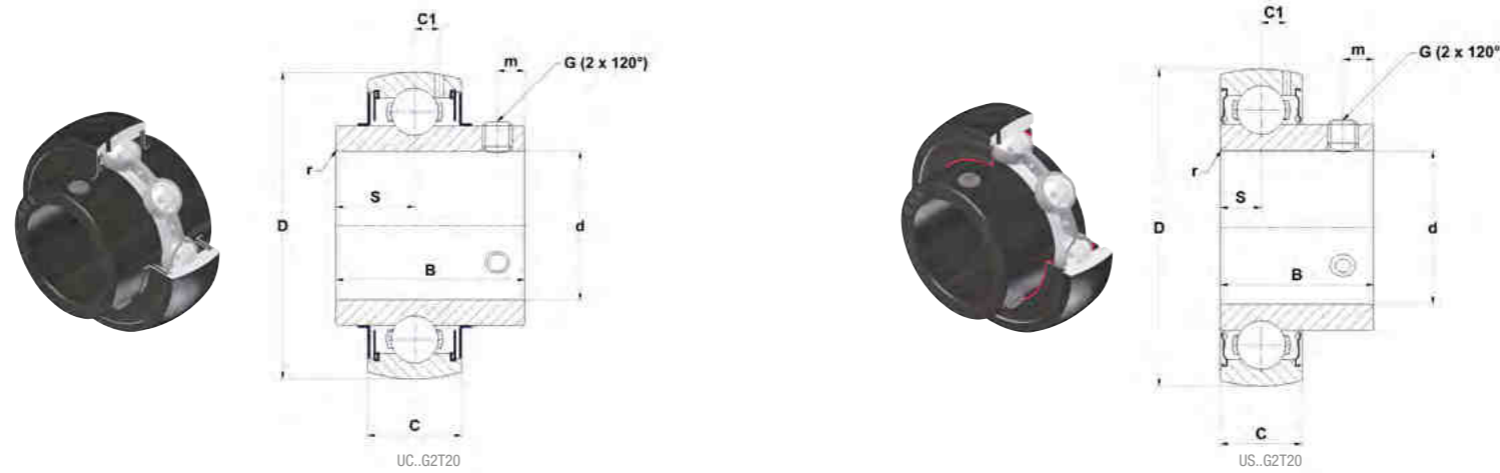

Main dimensions [mm]

d	Bearing insert	D	C	B	S	m	C1	r min	G	SW*	Set screw torque [Nm]	min Temp [°C]	max Temp [°C]	Dynamic load rating C [kN]	Static load rating C0 [kN]	Weight [kg]	d
12	UC201G2T20	47	16	31	12,7	4,7	4,4	0,6	M6x1	3	5,5	-20	200	12,8	6,7	0,2	12
	US201G2T20	40	12	22	6	4	3,6	0,6	M5x0,8	2,5	3,5	-20	200	9,6	4,8	0,1	12
15	UC202G2T20	47	16	31	12,7	4,7	4,4	0,6	M6x1	3	5,5	-20	200	12,8	6,7	0,2	15
	US202G2T20	40	12	22	6	4	3,6	0,6	M5x0,8	2,5	3,5	-20	200	9,6	4,8	0,1	15
17	UC203G2T20	47	16	31	12,7	4,7	4,4	0,6	M6x1	3	5,5	-20	200	12,8	6,7	0,2	17
	US203G2T20	40	12	22	6	4	3,6	0,6	M5x0,8	2,5	3,5	-20	200	9,6	4,8	0,1	17
20	UC204G2T20	47	16	31	12,7	4,7	4,4	0,6	M6x1	3	5,5	-20	200	12,8	6,7	0,2	20
	US204G2T20	47	14	25	7	5	4	0,6	M6x1	3	5,5	-20	200	12,8	6,7	0,1	20
25	UC205G2T20	52	17	34	14,3	5,5	4,3	0,6	M6x1	3	5,5	-20	200	14,0	7,9	0,2	25
	US205G2T20	52	15	27	7,5	5,5	4,3	0,6	M6x1	3	5,5	-20	200	14,0	7,9	0,2	25
30	UC206G2T20	62	19	38,1	15,9	5,5	5	0,6	M6x1	3	5,5	-20	200	19,5	11,2	0,3	30
	US206G2T20	62	16	30	8	6	5	0,6	M6x1	3	5,5	-20	200	19,5	11,2	0,3	30
35	UC207G2T20	72	20	42,9	17,5	6,5	5,8	1,1	M8x1	4	11,5	-20	200	25,7	15,2	0,5	35
	US207G2T20	72	17	32	8,5	6,5	5,7	0,6	M6x1	3	5,5	-20	200	25,7	15,2	0,4	35
40	UC208G2T20	80	21	49,2	19	8	6,3	1,1	M8x1	4	11,5	-20	200	29,6	18,2	0,6	40
	US208G2T20	80	18	34	9	7	6,2	1,1	M8x1	4	11,5	-20	200	32,6	19,9	0,6	40
45	UC209G2T20	85	22	49,2	19	8	6,8	1,1	M8x1	4	11,5	-20	200	31,9	20,8	0,7	45
	US209G2T20	85	19	41,2	10,2	8,2	6,5	1,1	M8x1	4	11,5	-20	200	31,9	20,8	0,7	45
50	UC210G2T20	90	23	51,6	19	9	6,5	1,1	M10x1,25	5	22	-20	200	35,1	23,2	0,8	50
	US210G2T20	90	20	43,5	10,9	9,2	6,5	1,1	M8x1	4	11,5	-20	200	35,1	23,2	0,8	50
55	UC211G2T20	100	25	55,6	22,2	9	7,2	1,1	M10x1,25	5	22	-20	200	43,6	29,2	1,1	55
	US211G2T20	100	23	45,3	11,8	9,8	7,2	1,1	M10x1,25	5	22	-20	200	43,6	29,2	1,1	55
60	UC212G2T20	110	27	65,1	25,4	10	8,2	1,1	M10x1,25	5	22	-20	200	52,5	32,8	1,5	60
	US212G2T20	110	24	53,7	14,9	9,8	8	1,1	M10x1,25	5	22	-20	200	52,5	32,8	1,3	60
65	UC213G2T20	120	28	65,1	25,4	12	8	1,5	M12x1,25	6	33	-20	200	57,2	40,0	1,9	65
70	UC214G2T20	125	30	74,6	30,2	12	9	2	M12x1,25	6	33	-20	200	62,0	45,0	2,1	70
75	UC215G2T20	130	30	77,8	33,3	12	9	2	M12x1,25	6	33	-20	200	66,0	49,5	2,2	75
80	UC216G2T20	140	33	82,6	33,3	14	10,3	2	M12x1,25	6	33	-20	200	72,5	54,2	2,8	80
85	UC217G2T20	150	35	85,7	34,1	14	11	2	M12x1,25	6	33	-20	200	83,2	63,8	3,4	85
90	UC218G2T20	160	37	96	39,7	14	12	2	M12x1,25	6	33	-20	200	96,0	71,5	4,5	90

*Width across flats (hexagon socket)

CHROME STEEL BEARING INSERTS WITH SPHERICAL OUTER RING

SET SCREW TYPES

For use with protective caps PCC / PCO

US2..G1N

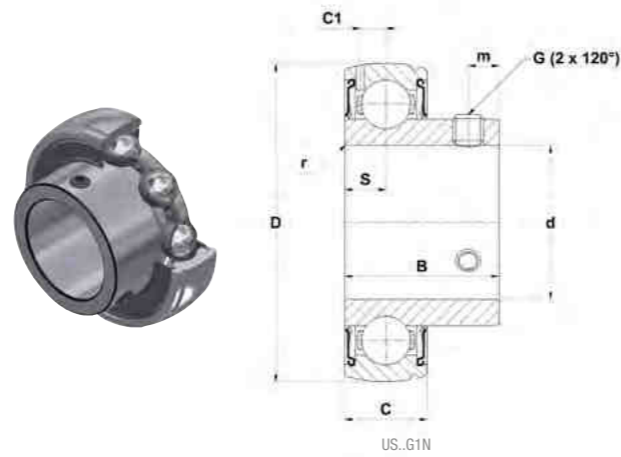

Main dimensions [mm]

d	Bearing insert	D	C	B	S	m	C1	r min	G	SW*	Set screw torque [Nm]	min Temp [°C]	max Temp [°C]	Dynamic load rating C [kN]	Static load rating C0 [kN]	Weight [kg]	d
25	US205G1N	52	15	27	7,5	5,5	4,3	0,6	M6x1	3	5,5	-20	100	14,0	7,9	0,2	25
30	US206G1N	62	16	30	8	6	5	0,6	M6x1	3	5,5	-20	100	19,5	11,2	0,3	30
35	US207G1N	72	17	32	8,5	6,5	5,7	0,6	M6x1	3	5,5	-20	100	25,7	15,2	0,4	35
40	US208G1N	80	18	34	9	7	6,2	1,1	M8x1	4	11,5	-20	100	29,6	18,2	0,6	40

*Width across flats (hexagon socket)

CHROME STEEL BEARING INSERTS WITH SPHERICAL OUTER RING

ADAPTER SLEEVE TYPES INCLUDED SLEEVES

Basic version

UK2..G2H

Narrow version

LK2..G2H

Heavy duty

UK3..G2H

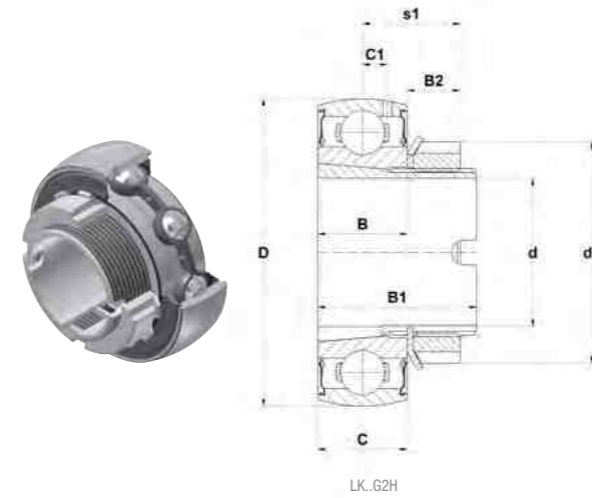
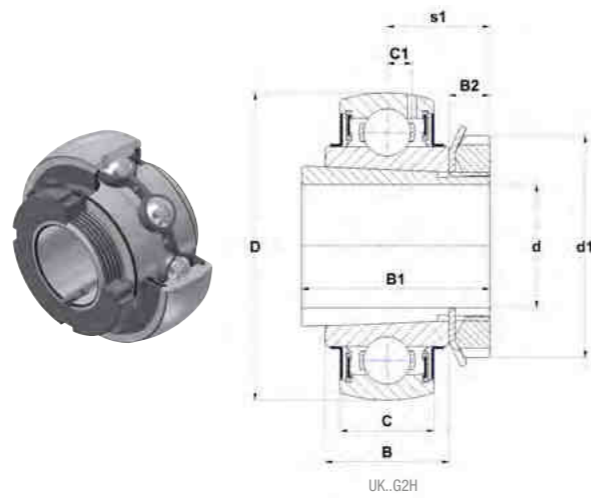

Main dimensions [mm]

d	Bearing insert	D	C	S1	d1	B	B1	B2	C1	min Temp [°C]	max Temp [°C]	Dynamic load rating C [kN]	Static load rating C0 [kN]	Weight [kg]	d
20	LK204G2H	47	14	16,5	32	15	28	9	4	-20	100	12,7	6,6	0,1	20
	UK205G2H	52	17	18,5	38	21	35	8	4,3	-20	100	14,0	7,9	0,2	
	UK305G2H	62	21	21,5	38	27	35	8	6,2	-20	100	22,4	11,5	0,5	
25	LK205G2H	52	15	16,7	38	15	28	9,2	4,3	-20	100	13,6	7,8	0,2	25
	UK206G2H	62	19	20,5	45	25	38	8	5	-20	100	19,5	11,2	0,4	
	UK306G2H	72	24	23	45	30	38	8	6,5	-20	100	27,0	15,2	0,6	
30	LK206G2H	62	18	19,7	45	18	32	10,7	5	-20	100	18,9	11,3	0,3	30
	UK207G2H	72	20	22,5	52	27	43	9	5,8	-20	100	25,7	15,2	0,5	
	UK307G2H	80	25	25,5	52	33	43	9	7,2	-20	100	33,5	19,2	0,9	
35	LK207G2H	72	19	20,7	52	19	34	11,2	5,8	-20	100	24,9	15,3	0,4	35
	UK208G2H	80	21	24,5	58	29	46	10	6,3	-20	100	29,6	18,2	0,7	
	UK308G2H	90	28	27,5	58	35	46	10	8,5	-20	100	40,6	24,0	1,0	
40	LK208G2H	80	21	23,2	58	22	38	12,2	6,3	-20	100	29,5	19,8	0,5	40
	UK209G2H	85	22	26	65	30	50	11	6,8	-20	100	31,9	20,8	0,8	
	UK309G2H	100	30	30	65	38	50	11	9	-20	100	53,0	31,8	1,5	
45	LK209G2H	85	22	23,2	62	22	38	12,2	6,8	-20	100	33,2	22,4	0,6	45
	UK210G2H	90	23	27,5	70	31	55	12	6,5	-20	100	35,1	23,2	1,0	
	UK310G2H	110	32	32	70	40	55	12	9,9	-20	100	62,0	37,8	1,7	
50	LK210G2H	90	22	25,2	70	22	40	14,2	6,5	-20	100	33,0	22,9	0,7	50
	UK211G2H	100	25	29	75	33	59	12,5	7,2	-20	100	43,6	29,2	1,2	
	UK311G2H	120	34	34	75	43	59	12,5	10,6	-20	100	71,5	44,8	2,2	
55	UK212G2H	110	27	31	80	36	62	13	8,2	-20	100	52,5	32,8	1,5	55
	UK312G2H	130	36	36,5	80	47	62	13	11,3	-20	100	81,6	51,8	2,5	
60	UK213G2H	120	28	32	85	36	65	14	8	-20	100	57,2	40,0	1,9	60
	UK313G2H	140	38	38,5	85	49	65	14	12,1	-20	100	93,9	60,5	3,3	
65	UK215G2H	130	30	35,5	98	41	73	15	9	-20	100	66,0	49,5	2,7	65
	UK315G2H	160	42	42,5	98	55	73	15	13,5	-20	100	113,4	76,8	5,0	
70	UK216G2H	140	33	39	105	44	78	17	10,3	-20	100	72,5	54,2	3,2	70
	UK316G2H	170	44	44,5	105	55	78	17	14,5	-20	100	122,9	86,5	5,8	
75	UK217G2H	150	35	40	110	44	82	18	11	-20	100	83,2	63,8	3,9	75
	UK317G2H	180	46	48	110	60	82	18	15,5	-20	100	132,6	96,5	6,9	
80	UK218G2H	160	37	42	120	48	86	18	12	-20	100	96,0	71,5	4,7	80
	UK318G2H	190	48	48	120	60	86	18	16,5	-20	100	143,0	108,0	7,9	
85	UK319G2H	200	50	52	125	66	90	19	16,7	-20	100	156,0	122,0	9,2	85
90	UK320G2H	215	54	54	130	68	97	20	19	-20	100	171,6	140,0	11,0	90
100	UK322G2H	240	60	61	145	80	105	21	21	-20	100	205,0	178,0	17,6	100
110	UK324G2H	260	64	65,5	155	87	112	22	22	-20	100	228,0	208,0	21,2	110
115	UK326G2H	280	68	68	165	90	121	23	23	-20	100	252,0	242,0	27,9	115
125	UK328G2H	300	72	73	180	98	131	24	25	-20	100	275,0	272,0	34,5	125

CHROME STEEL BEARING INSERTS WITH SPHERICAL OUTER RING

INTERFERENCE FIT TYPES

Basic version
CS2

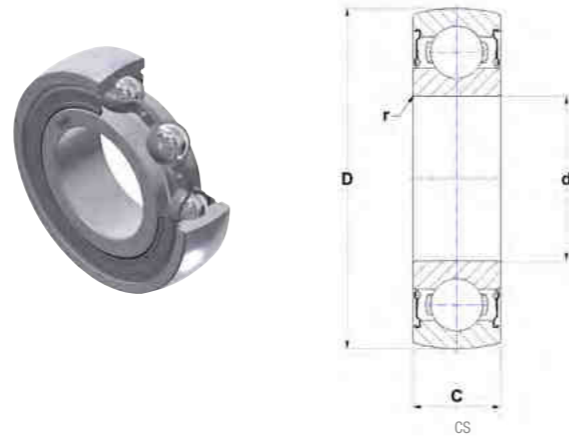

Main dimensions [mm]

d	Bearing insert	D	C	r min	min Temp [°C]	max Temp [°C]	Dynamic load rating C [kN]	Static load rating C0 [kN]	Weight [kg]	d
17	CS203	40	12	0,6	-20	100	9,6	4,8	0,1	17
20	CS204	47	14	0,6	-20	100	12,8	6,7	0,1	20
25	CS205	52	15	0,6	-20	100	14,0	7,9	0,1	25
30	CS206	62	16	0,6	-20	100	19,5	11,5	0,2	30
35	CS207	72	17	1,1	-20	100	25,5	15,2	0,3	35
40	CS208	80	18	1,1	-20	100	29,5	18,0	0,3	40
45	CS209	85	19	1,1	-20	100	31,5	20,8	0,4	45

∅ d: Inner ring bore according ISO 492 rather DIN 620-2

CHROME STEEL BEARING INSERTS WITH CYLINDRICAL OUTER RING

ECCENTRIC LOCKING COLLAR TYPES

Wide design with snap ring groove and lubrication facility **CEX2**

Narrow design with snap ring groove without lubrication facility **CES2**

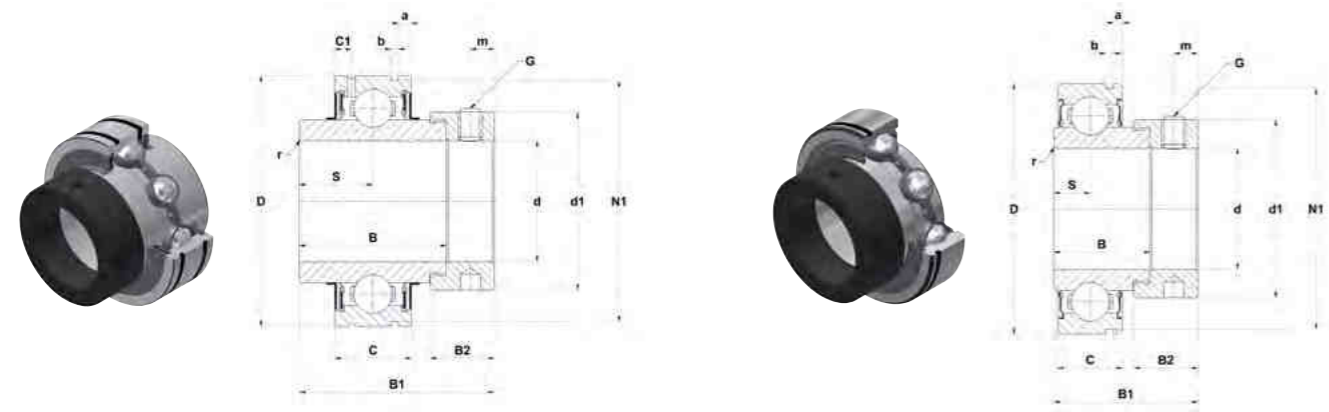

Main dimensions [mm]

d	Bearing insert	D	C	B	B1	B2	S	d1	C1	a	b	N1	r min	m	G	SW*	Set screw torque [Nm]	min Temp [°C]	max Temp [°C]	Dynamic load rating C [kN]	Static load rating CO [kN]	Weight [kg]	d
15	CES202	40	12	19,1	28,6	13,5	6,5	28,6	-	1,98	1,35	38,1	0,6	5	M6x1	3	5,5	-20	100	9,6	4,8	0,1	15
	CEX204	47	14	21,5	31	13,5	7	33,3	-	4	1,35	44,6	1	5	M6x1	3	5,5	-20	100	12,8	6,7	0,2	20
	CEX204	47	17	34,2	43,7	13,5	17,1	33,3	4	3,1	1,35	44,6	1	5	M6x1	3	5,5	-20	100	12,8	6,7	0,2	20
	CUC204	47	17	31	-	-	12,7	-	4	3,1	1,35	44,6	0,6	4,5	M6x1	3	5,5	-20	100	12,8	6,7	0,2	20
25	CUS204	47	14	25	-	-	7	-	-	2,38	1,35	44,6	1	5	M6x1	3	5,5	-20	100	12,8	6,7	0,1	20
	CES205	52	15	21,5	31	13,5	7,5	38,1	-	2,38	1,35	49,73	1	5	M6x1	3	5,5	-20	100	14,0	7,9	0,2	25
	CEX205	52	17	34,9	44,4	13,5	17,5	38,1	4,1	3,2	1,35	49,73	1	5	M6x1	3	5,5	-20	100	14,0	7,9	0,3	25
	CUC205	52	17	34	-	-	14,3	-	4,1	3,2	1,35	49,73	0,6	5	M6x1	3	5,5	-20	100	14,0	7,9	0,2	25
30	CUS205	52	15	27	-	-	7,5	-	-	2,38	1,35	49,73	1	5	M6x1	3	5,5	-20	100	14,0	7,9	0,2	25
	CES206	62	16	23,8	35,7	15,9	8	44,5	-	3,18	1,9	59,61	1	6	M6x1	3	5,5	-20	100	19,5	11,2	0,3	30
	CEX206	62	19	36,5	48,4	15,9	18,3	44,5	4,2	3,2	1,9	59,61	1,5	6	M6x1	3	5,5	-20	100	19,5	11,2	0,4	30
	CUC206	62	19	38,1	-	-	15,9	-	4,2	3,2	1,9	59,61	0,6	5,5	M6x1	3	5,5	-20	100	19,5	11,2	0,4	30
35	CUS206	62	16	30	-	-	8	-	-	3,18	1,9	59,61	1	5,5	M6x1	3	5,5	-20	100	19,5	11,2	0,3	30
	CES207	72	17	25,4	38,9	17,5	8,5	55,6	-	3,18	1,9	68,81	1,5	6,5	M8x1	4	11,5	-20	100	25,7	15,2	0,5	35
	CEX207	72	20	37,6	51,1	17,5	18,8	55,5	5	3,3	1,9	68,81	1,5	6,5	M8x1	4	11,5	-20	100	25,7	15,2	0,6	35
	CUC207	72	20	42,9	-	-	17,5	-	5	3,3	1,9	68,81	1,1	6,5	M8x1	4	11,5	-20	100	25,7	15,2	0,5	35
40	CUS207	72	17	32	-	-	8,5	-	-	3,18	1,9	68,81	1	6	M6x1	3	5,5	-20	100	25,7	15,2	0,4	35
	CES208	80	18	30,2	43,7	18,3	9	60,3	-	3,18	1,9	76,81	1,5	6,5	M8x1	4	11,5	-20	100	32,6	19,9	0,7	40
	CEX208	80	21	42,8	56,3	18,3	21,4	60,3	5	3,4	1,9	76,81	1,5	6,5	M8x1	4	11,5	-20	100	32,6	19,9	0,8	40
	CUC208	80	21	49,2	-	-	19	-	5	3,4	1,9	76,81	1,1	8	M8x1	4	11,5	-20	100	32,6	19,9	0,6	40
45	CUS208	80	18	34	-	-	9	-	-	3,18	1,9	76,81	1	8	M8x1	4	11,5	-20	100	32,6	19,9	0,5	40
	CES209	85	19	30,2	43,7	18,3	9,5	63,5	-	3,18	1,9	81,81	1,5	6,5	M8x1	4	11,5	-20	100	31,9	20,8	0,7	45
	CEX209	85	22	42,8	56,3	18,3	21,4	63,5	5,1	3,5	1,9	81,81	1,5	6,5	M8x1	4	11,5	-20	100	31,9	20,8	0,9	45
	CUC209	85	22	49,2	-	-	19	-	5,1	3,5	1,9	81,81	1,1	8	M8x1	4	11,5	-20	100	31,9	20,8	0,7	45
50	CUS209	85	19	41,2	-	-	9,5	-	-	3,18	1,9	81,81	1,5	8	M8x1	4	11,5	-20	100	31,9	20,8	0,6	45
	CES210	90	20	30,2	43,7	18,3	10	69,9	-	3,7	2,7	86,79	1,5	6,5	M8x1	4	11,5	-20	100	35,1	23,2	0,8	50
	CEX210	90	24	49,2	62,7	18,3	24,6	69,5	5,6	3,7	2,7	86,79	1,5	6,5	M8x1	4	11,5	-20	100	35,1	23,2	1,0	50
	CUC210	90	24	51,6	-	-	19	-	5,6	3,7	2,7	86,79	1,1	9	M10x1,25	5	22	-20	100	35,1	23,2	0,8	50
50	CUS210	90	20	43,5	-	-	10	-	-	3,7	2,7	86,79	1,5	9	M8x1	4	11,5	-20	100	35,1	23,2	0,7	50

*Width across flats (hexagon socket)

CHROME STEEL BEARING INSERTS WITH SPHERICAL OUTER RING

ECCENTRIC LOCKING COLLAR TYPES

Triple lip seal version L3

EX2..G2L3

Multiple seal system L4

EX2..G2L4

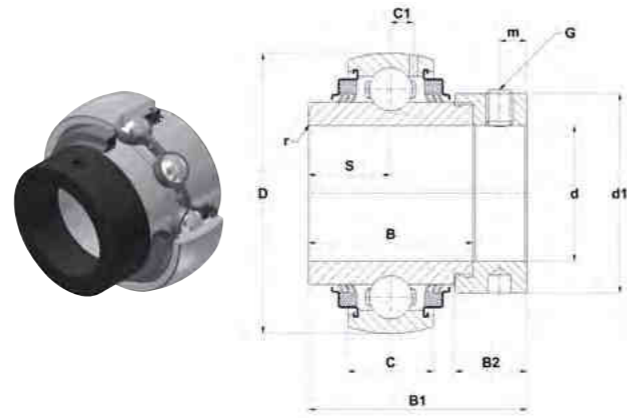

EX..G2L3

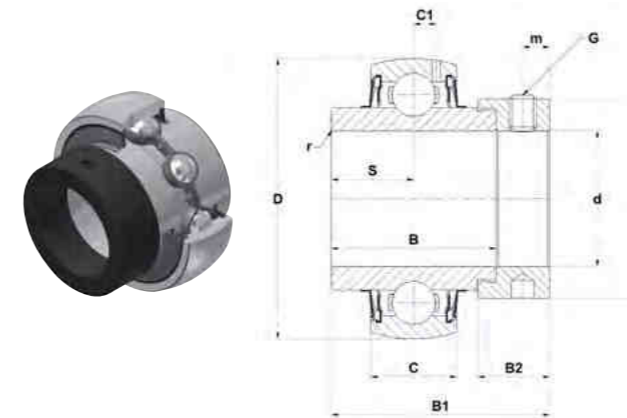

EX..G2L4

Main dimensions [mm]

d [inch]	d [mm]	Bearing insert	D	C	B	B1	B2	d1	S	m	C1	r min	G	SW*	Set screw torque [Nm]	min Temp [°C]	max Temp [°C]	Dynamic load rating C [kN]	Static load rating C0 [kN]	Weight [kg]	d [inch]
1/2	12,7	EX201-08G2L4	47	16	34	43,5	13,5	32,4	17	5	4,4	0,6	1/4-28UNF	1/8	3,7	-20	100	12,8	6,7	0,3	1/2
5/8	15,875	EX202-10G2L3	47	16	34	43,5	13,5	32,4	17	5	4,4	0,6	1/4-28UNF	1/8	3,7	-20	100	12,8	6,7	0,3	5/8
		EX202-10G2L4	47	16	34	43,5	13,5	32,4	17	5	4,4	0,6	1/4-28UNF	1/8	3,7	-20	100	12,8	6,7	0,3	
11/16	17,463	EX203-11G2L3	47	16	34	43,5	13,5	32,4	17	5	4,4	0,6	1/4-28UNF	1/8	3,7	-20	100	12,8	6,7	0,2	11/16
		EX203-11G2L4	47	16	34	43,5	13,5	32,4	17	5	4,4	0,6	1/4-28UNF	1/8	3,7	-20	100	12,8	6,7	0,2	
3/4	19,05	EX204-12G2L3	47	16	34	43,5	13,5	32,4	17	5	4,4	0,6	1/4-28UNF	1/8	3,7	-20	100	12,8	6,7	0,2	3/4
		EX204-12G2L4	47	16	34	43,5	13,5	32,4	17	5	4,4	0,6	1/4-28UNF	1/8	3,7	-20	100	12,8	6,7	0,2	
7/8	22,225	EX205-14G2L3	52	17	34,8	44,3	13,5	37,4	17,4	5	4,3	0,6	1/4-28UNF	1/8	3,7	-20	100	14,0	7,9	0,3	7/8
		EX205-14G2L4	52	17	34,8	44,3	13,5	37,4	17,4	5	4,3	0,6	1/4-28UNF	1/8	3,7	-20	100	14,0	7,9	0,3	
15/16	23,813	EX205-15G2L3	52	17	34,8	44,3	13,5	37,4	17,4	5	4,3	0,6	1/4-28UNF	1/8	3,7	-20	100	14,0	7,9	0,3	15/16
		EX205-15G2L4	52	17	34,8	44,3	13,5	37,4	17,4	5	4,3	0,6	1/4-28UNF	1/8	3,7	-20	100	14,0	7,9	0,3	
1	25,4	EX205-16G2L3	52	17	34,8	44,3	13,5	37,4	17,4	5	4,3	0,6	1/4-28UNF	1/8	3,7	-20	100	14,0	7,9	0,2	1
		EX205-16G2L4	52	17	34,8	44,3	13,5	37,4	17,4	5	4,3	0,6	1/4-28UNF	1/8	3,7	-20	100	14,0	7,9	0,2	
1 1/8	28,575	EX206-18G2L3	62	19	36,4	48,3	15,9	44,1	18,2	6	5	0,6	5/16-24UNF	5/32	8	-20	100	19,5	11,2	0,4	1 1/8
		EX206-18G2L4	62	19	36,4	48,3	15,9	44,1	18,2	6	5	0,6	5/16-24UNF	5/32	8	-20	100	19,5	11,2	0,4	
1 3/16	30,163	EX206-19G2L3	62	19	36,4	48,3	15,9	44,1	18,2	6	5	0,6	5/16-24UNF	5/32	8	-20	100	19,5	11,2	0,4	1 3/16
		EX206-19G2L4	62	19	36,4	48,3	15,9	44,1	18,2	6	5	0,6	5/16-24UNF	5/32	8	-20	100	19,5	11,2	0,4	
1 1/4	31,75	EX206-20G2L3	62	19	36,4	48,3	15,9	44,1	18,2	6	5	0,6	5/16-24UNF	5/32	8	-20	100	19,5	11,2	0,4	1 1/4
		EX206-20G2L4	62	19	36,4	48,3	15,9	44,1	18,2	6	5	0,6	5/16-24UNF	5/32	8	-20	100	19,5	11,2	0,4	
		EX207-20G2L3	72	20	37,6	51,1	17,5	51,1	18,8	6,5	5,8	1,1	5/16-24UNF	5/32	8	-20	100	25,7	15,2	0,7	
		EX207-20G2L4	72	20	37,6	51,1	17,5	51,1	18,8	6,5	5,8	1,1	5/16-24UNF	5/32	8	-20	100	25,7	15,2	0,7	
1 5/16	33,338	EX207-21G2L3	72	20	37,6	51,1	17,5	51,1	18,8	6,5	5,8	1,1	5/16-24UNF	5/32	8	-20	100	25,7	15,2	0,6	1 5/16
		EX207-21G2L4	72	20	37,6	51,1	17,5	51,1	18,8	6,5	5,8	1,1	5/16-24UNF	5/32	8	-20	100	25,7	15,2	0,6	
1 3/8	34,925	EX207-22G2L3	72	20	37,6	51,1	17,5	51,1	18,8	6,5	5,8	1,1	5/16-24UNF	5/32	8	-20	100	25,7	15,2	0,6	1 3/8
		EX207-22G2L4	72	20	37,6	51,1	17,5	51,1	18,8	6,5	5,8	1,1	5/16-24UNF	5/32	8	-20	100	25,7	15,2	0,6	
1 7/16	36,513	EX207-23G2L3	72	20	37,6	51,1	17,5	51,1	18,8	6,5	5,8	1,1	5/16-24UNF	5/32	8	-20	100	25,7	15,2	0,6	1 7/16
		EX207-23G2L4	72	20	37,6	51,1	17,5	51,1	18,8	6,5	5,8	1,1	5/16-24UNF	5/32	8	-20	100	25,7	15,2	0,6	
1 1/2	38,1	EX208-24G2L3	80	21	42,8	56,3	18,3	58	21,4	6,5	6,3	1,1	5/16-24UNF	5/32	8	-20	100	29,6	18,2	0,8	1 1/2
		EX208-24G2L4	80	21	42,8	56,3	18,3	58	21,4	6,5	6,3	1,1	5/16-24UNF	5/32	8	-20	100	29,6	18,2	0,8	
1 9/16	39,688	EX208-25G2L3	80	21	42,8	56,3	18,3	58	21,4	6,5	6,3	1,1	5/16-24UNF	5/32	8	-20	100	29,6	18,2	0,8	1 9/16
		EX208-25G2L4	80	21	42,8	56,3	18,3	58	21,4	6,5	6,3	1,1	5/16-24UNF	5/32	8	-20	100	29,6	18,2	0,8	
1 5/8	41,275	EX209-26G2L3	85	22	42,8	56,3	18,3	62	21,4	6,5	6,8	1,1	5/16-24UNF	5/32	8	-20	100	31,9	20,8	1,0	1 5/8
		EX209-26G2L4	85	22	42,8	56,3	18,3	62	21,4	6,5	6,8	1,1	5/16-24UNF	5/32	8	-20	100	31,9	20,8	1,0	

*Width across flats (hexagon socket)

CHROME STEEL BEARING INSERTS WITH SPHERICAL OUTER RING

ECCENTRIC LOCKING COLLAR TYPES

Triple lip seal version L3

EX2..G2L3

Multiple seal system L4

EX2..G2L4

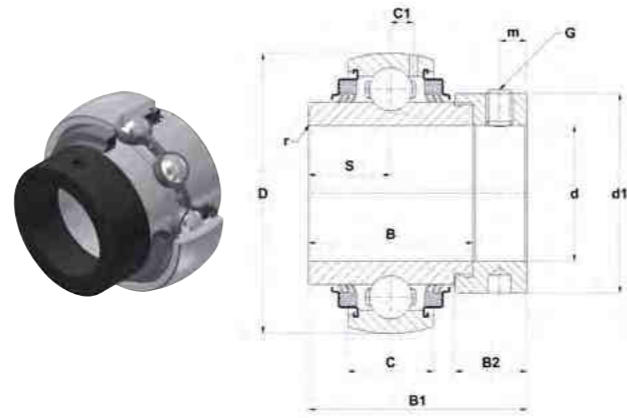

EX..G2L3

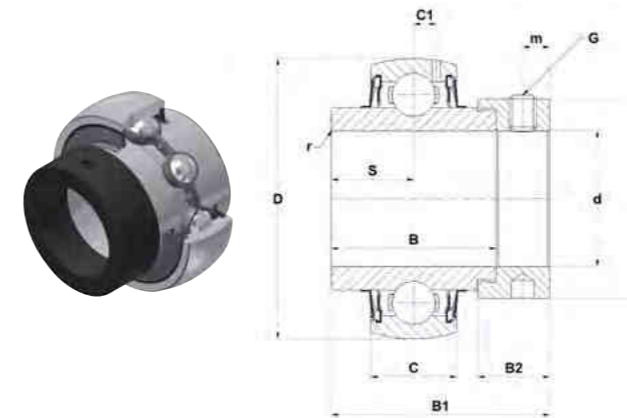

EX..G2L4

Main dimensions [mm]

d [inch]	d [mm]	Bearing insert	D	C	B	B1	B2	d1	S	m	C1	r min	G	SW*	Set screw torque [Nm]	min Temp [°C]	max Temp [°C]	Dynamic load rating C [kN]	Static load rating C0 [kN]	Weight [kg]	d [inch]
1 11/16	42,863	EX209-27G2L3	85	22	42,8	56,3	18,3	62	21,4	6,5	6,8	1,1	5/16-24UNF	5/32	8	-20	100	31,9	20,8	0,9	1 11/16
		EX209-27G2L4	85	22	42,8	56,3	18,3	62	21,4	6,5	6,8	1,1	5/16-24UNF	5/32	8	-20	100	31,9	20,8	0,9	
1 3/4	44,45	EX209-28G2L3	85	22	42,8	56,3	18,3	62	21,4	6,5	6,8	1,1	5/16-24UNF	5/32	8	-20	100	31,9	20,8	0,9	1 3/4
		EX209-28G2L4	85	22	42,8	56,3	18,3	62	21,4	6,5	6,8	1,1	5/16-24UNF	5/32	8	-20	100	31,9	20,8	0,9	
1 7/8	47,625	EX210-30G2L3	90	23	49,2	62,7	18,3	67,2	24,6	6,5	6,5	1,1	5/16-24UNF	5/32	8	-20	100	35,1	23,2	1,1	1 7/8
		EX210-30G2L4	90	23	49,2	62,7	18,3	67,2	24,6	6,5	6,5	1,1	5/16-24UNF	5/32	8	-20	100	35,1	23,2	1,1	
1 15/16	49,213	EX210-31G2L3	90	23	49,2	62,7	18,3	67,2	24,6	6,5	6,5	1,1	5/16-24UNF	5/32	8	-20	100	35,1	23,2	1,0	1 15/16
		EX210-31G2L4	90	23	49,2	62,7	18,3	67,2	24,6	6,5	6,5	1,1	5/16-24UNF	5/32	8	-20	100	35,1	23,2	1,0	
2	50,8	EX211-32G2L3	100	25	55,4	71,3	20,7	74,5	27,7	8	7,2	1,5	3/8-24UNF	3/16	16,8	-20	100	43,6	29,2	1,6	2
2 1/8	53,975	EX211-34G2L3	100	25	55,4	71,3	20,7	74,5	27,7	8	7,2	1,5	3/8-24UNF	3/16	16,8	-20	100	43,6	29,2	1,4	2 1/8
2 3/16	55,563	EX211-35G2L3	100	25	55,4	71,3	20,7	74,5	27,7	8	7,2	1,5	3/8-24UNF	3/16	16,8	-20	100	43,6	29,2	1,4	2 3/16
2 1/4	57,15	EX212-36G2L3	110	27	61,8	77,7	22,3	82	30,9	8	8,2	1,5	3/8-24UNF	3/16	16,8	-20	100	52,5	32,8	2,0	2 1/4
2 3/8	60,325	EX212-38G2L3	110	27	61,8	77,7	22,3	82	30,9	8	8,2	1,5	3/8-24UNF	3/16	16,8	-20	100	52,5	32,8	1,8	2 3/8
2 7/16	61,913	EX212-39G2L3	110	27	61,8	77,7	22,3	82	30,9	8	8,2	1,5	3/8-24UNF	3/16	16,8	-20	100	52,5	32,8	1,8	2 7/16
2 1/2	63,5	EX213-40G2L3	120	28	68,2	85,7	23,5	86	34,1	8,5	8	1,5	3/8-24UNF	3/16	16,8	-20	100	57,2	40,0	2,5	2 1/2
2 11/16	68,263	EX214-43G2L3	125	30	68,2	85,7	23,5	96,8	34,1	8,5	9	2	3/8-24UNF	3/16	16,8	-20	100	62,0	45,0	2,6	2 11/16
2 3/4	69,85	EX214-44G2L3	125	30	68,2	85,7	23,5	96,8	34,1	8,5	9	2	3/8-24UNF	3/16	16,8	-20	100	62,0	45,0	2,6	2 3/4
2 15/16	74,613	EX215-47G2L3	130	30	74,6	92,1	23,9	102	37,3	8,5	9	2	3/8-24UNF	3/16	16,8	-20	100	66,0	49,5	2,8	2 15/16
3	76,2	EX215-48G2L3	130	30	74,6	92,1	23,9	102	37,3	8,5	9	2	3/8-24UNF	3/16	16,8	-20	100	66,0	49,5	2,7	3
3 3/16	80,963	EX216-51G2L3	140	33	74,6	95,2	27	110	37,3	10,3	10,3	2	3/8-24UNF	3/16	16,8	-20	100	72,5	54,2	3,1	3 3/16
3 1/4	82,55	EX217-52G2L3	150	35	53,2	73,2	27	119	23,4	10	11	2	7/16-20UNF	7/32	27,1	-20	100	83,2	63,8	3,7	3 1/4
3 1/2	88,9	EX218-56G2L3	160	37	55	72,5	24	120	24,5	9,5	12	2	7/16-20UNF	7/32	27,1	-20	100	96,0	71,5	5,0	3 1/2

*Width across flats (hexagon socket)

CHROME STEEL BEARING INSERTS WITH SPHERICAL OUTER RING

ECCENTRIC LOCKING COLLAR TYPES

High temperature version T20

EX2..G2T20

ES2..G2T20

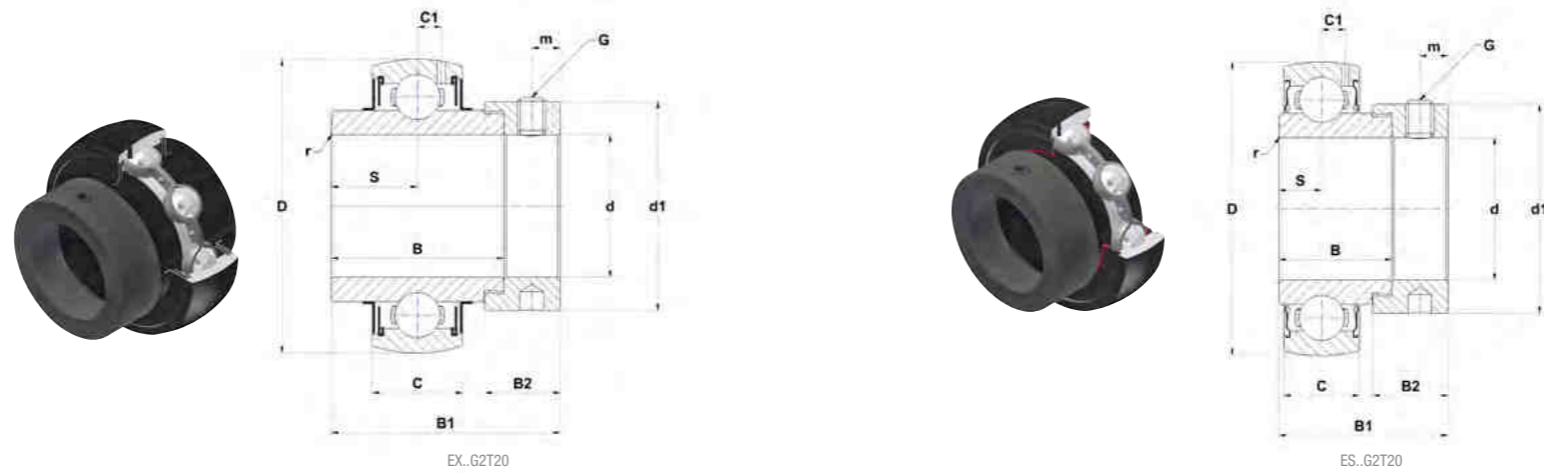

Main dimensions [mm]

d [inch]	d [mm]	Bearing insert	D	C	B	B1	B2	d1	S	m	C1	r min	G	SW*	Set screw torque [Nm]	min Temp [°C]	max Temp [°C]	Dynamic load rating C [kN]	Static load rating C0 [kN]	Weight [kg]	d [inch]
1/2	12,7	ES201-08G2T20	40	12	19,1	28,6	13,5	27,2	6,5	5	3,6	0,6	1/4-28UNF	1/8	3,7	-20	200	9,6	4,8	0,1	1/2
		EX201-08G2T20	47	16	34	43,5	13,5	32,4	17	5	4,4	0,6	1/4-28UNF	1/8	3,7	-20	200	12,8	6,7	0,3	
5/8	15,875	ES202-10G2T20	40	12	19,1	28,6	13,5	27,2	6,5	5	3,6	0,6	1/4-28UNF	1/8	3,7	-20	200	9,6	4,8	0,1	5/8
		EX202-10G2T20	47	16	34	43,5	13,5	32,4	17	5	4,4	0,6	1/4-28UNF	1/8	3,7	-20	200	12,8	6,7	0,3	
11/16	17,463	ES203-11G2T20	40	12	19,1	28,6	13,5	27,2	6,5	5	3,6	0,6	1/4-28UNF	1/8	3,7	-20	200	9,6	4,8	0,1	11/16
		EX203-11G2T20	47	16	34	43,5	13,5	32,4	17	5	4,4	0,6	1/4-28UNF	1/8	3,7	-20	200	12,8	6,7	0,2	
3/4	19,05	ES204-12G2T20	47	14	21,4	30,9	13,5	32,4	7,5	5	4	0,6	1/4-28UNF	1/8	3,7	-20	200	12,8	6,7	0,2	3/4
		EX204-12G2T20	47	16	34	43,5	13,5	32,4	17	5	4,4	0,6	1/4-28UNF	1/8	3,7	-20	200	12,8	6,7	0,2	
7/8	22,225	ES205-14G2T20	52	15	21,4	30,9	13,5	37,4	7,5	5	4,3	0,6	1/4-28UNF	1/8	3,7	-20	200	14,0	7,9	0,2	7/8
		EX205-14G2T20	52	17	34,8	44,3	13,5	37,4	17,4	5	4,3	0,6	1/4-28UNF	1/8	3,7	-20	200	14,0	7,9	0,3	
15/16	23,813	ES205-15G2T20	52	15	21,4	30,9	13,5	37,4	7,5	5	4,3	0,6	1/4-28UNF	1/8	3,7	-20	200	14,0	7,9	0,2	15/16
		EX205-15G2T20	52	17	34,8	44,3	13,5	37,4	17,4	5	4,3	0,6	1/4-28UNF	1/8	3,7	-20	200	14,0	7,9	0,3	
1	25,4	ES205-16G2T20	52	15	21,4	30,9	13,5	37,4	7,5	5	4,3	0,6	1/4-28UNF	1/8	3,7	-20	200	14,0	7,9	0,2	1
		EX205-16G2T20	52	17	34,8	44,3	13,5	37,4	17,4	5	4,3	0,6	1/4-28UNF	1/8	3,7	-20	200	14,0	7,9	0,2	
1 1/8	28,575	ES206-18G2T20	62	16	23,8	35,7	15,9	44,1	9	6	5	0,6	5/16-24UNF	5/32	8	-20	200	19,5	11,2	0,4	1 1/8
		EX206-18G2T20	62	19	36,4	48,3	15,9	44,1	18,2	6	5	0,6	5/16-24UNF	5/32	8	-20	200	19,5	11,2	0,4	
1 3/16	30,163	ES206-19G2T20	62	16	23,8	35,7	15,9	44,1	9	6	5	0,6	5/16-24UNF	5/32	8	-20	200	19,5	11,2	0,3	1 3/16
		EX206-19G2T20	62	19	36,4	48,3	15,9	44,1	18,2	6	5	0,6	5/16-24UNF	5/32	8	-20	200	19,5	11,2	0,4	
1 1/4	31,75	ES206-20G2T20	62	16	23,8	35,7	15,9	44,1	9	6	5	0,6	5/16-24UNF	5/32	8	-20	200	19,5	11,2	0,3	1 1/4
		EX206-20G2T20	62	19	36,4	48,3	15,9	44,1	18,2	6	5	0,6	5/16-24UNF	5/32	8	-20	200	19,5	11,2	0,4	
		EX207-20G2T20	72	20	37,6	51,1	17,5	51,1	18,8	6,5	5,8	1,1	5/16-24UNF	5/32	8	-20	200	25,7	15,2	0,7	
1 5/16	33,338	EX207-21G2T20	72	20	37,6	51,1	17,5	51,1	18,8	6,5	5,8	1,1	5/16-24UNF	5/32	8	-20	200	25,7	15,2	0,6	1 5/16
		ES207-22G2T20	72	17	25,4	38,9	17,5	51,1	9,5	6,5	5,7	1,1	5/16-24UNF	5/32	8	-20	200	25,7	15,2	0,5	1 3/8
1 3/8	34,925	EX207-22G2T20	72	20	37,6	51,1	17,5	51,1	18,8	6,5	5,8	1,1	5/16-24UNF	5/32	8	-20	200	25,7	15,2	0,6	
		ES207-23G2T20	72	17	25,4	38,9	17,5	51,1	9,5	6,5	5,7	1,1	5/16-24UNF	5/32	8	-20	200	25,7	15,2	0,5	1 7/16
1 7/16	36,513	EX207-23G2T20	72	20	37,6	51,1	17,5	51,1	18,8	6,5	5,8	1,1	5/16-24UNF	5/32	8	-20	200	25,7	15,2	0,6	
		ES208-24G2T20	80	18	30,2	43,7	18,3	58	11	6,5	6,2	1,1	5/16-24UNF	5/32	8	-20	200	29,6	18,2	0,7	1 1/2
1 1/2	38,1	EX208-24G2T20	80	21	42,8	56,3	18,3	60,3	21,4	6,5	6,3	1,1	5/16-24UNF	5/32	8	-20	200	29,6	18,2	0,8	
		ES208-25G2T20	80	21	42,8	56,3	18,3	60,3	21,4	6,5	6,3	1,1	5/16-24UNF	5/32	8	-20	200	29,6	18,2	0,8	1 9/16
1 9/16	39,688	EX208-25G2T20	80	21	42,8	56,3	18,3	60,3	21,4	6,5	6,3	1,1	5/16-24UNF	5/32	8	-20	200	29,6	18,2	0,8	
		ES209-26G2T20	85	19	30,2	43,7	18,3	62	11	6,5	6,5	1,1	5/16-24UNF	5/32	8	-20	200	31,9	20,8	0,8	1 5/8
1 5/8	41,275	EX209-26G2T20	85	22	42,8	56,3	18,3	62	21,4	6,5	6,8	1,1	5/16-24UNF	5/32	8	-20	200	31,9	20,8	1,0	
		ES209-27G2T20	85	19	30,2	43,7	18,3	62	11	6,5	6,5	1,1	5/16-24UNF	5/32	8	-20	200	31,9	20,8	0,8	1 11/16
1 11/16	42,863	EX209-27G2T20	85	22	42,8	56,3	18,3	62	21,4	6,5	6,8	1,1	5/16-24UNF	5/32	8	-20	200	31,9	20,8	0,9	

*Width across flats (hexagon socket)

CHROME STEEL BEARING INSERTS WITH SPHERICAL OUTER RING

ECCENTRIC LOCKING COLLAR TYPES

High temperature version T20

EX2..G2T20

ES2..G2T20

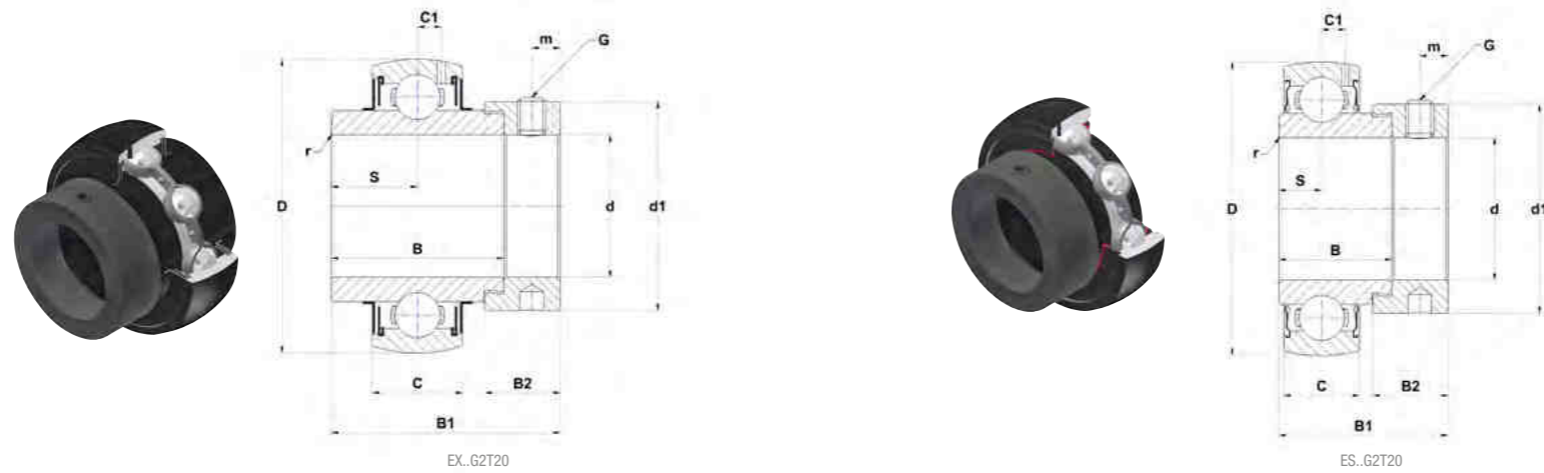

Main dimensions [mm]

d [inch]	d [mm]	Bearing insert	D	C	B	B1	B2	d1	S	m	C1	r min	G	SW*	Set screw torque [Nm]	min Temp [°C]	max Temp [°C]	Dynamic load rating C [kN]	Static load rating C0 [kN]	Weight [kg]	d [inch]
1 3/4	44,45	ES209-28G2T20	85	19	30,2	43,7	18,3	62	11	6,5	6,5	1,1	5/16-24UNF	5/32	8	-20	200	31,9	20,8	0,7	1 3/4
		EX209-28G2T20	85	22	42,8	56,3	18,3	62	21,4	6,5	6,8	1,1	5/16-24UNF	5/32	8	-20	200	31,9	20,8	0,9	
1 7/8	47,625	ES210-30G2T20	90	20	30,2	43,7	18,3	67,2	11	6,5	6,5	1,1	5/16-24UNF	5/32	8	-20	200	35,1	23,2	0,9	1 7/8
		EX210-30G2T20	90	23	49,2	62,7	18,3	67,2	24,6	6,5	6,5	1,1	5/16-24UNF	5/32	8	-20	200	35,1	23,2	1,1	
1 15/16	49,213	ES210-31G2T20	90	20	30,2	43,7	18,3	67,2	11	6,5	6,5	1,1	5/16-24UNF	5/32	8	-20	200	35,1	23,2	0,8	1 15/16
		EX210-31G2T20	90	23	49,2	62,7	18,3	67,2	24,6	6,5	6,5	1,1	5/16-24UNF	5/32	8	-20	200	35,1	23,2	1,0	
2	50,8	ES211-32G2T20	100	24	32,5	48,4	20,7	74,5	12	8	7,2	1,1	3/8-24UNF	3/16	16,8	-20	200	43,6	29,2	1,2	2
		EX211-32G2T20	100	25	55,4	71,3	20,7	74,5	27,7	8	7,2	1,5	3/8-24UNF	3/16	16,8	-20	200	43,6	29,2	1,6	
2 1/8	53,975	EX211-34G2T20	100	25	55,4	71,3	20,7	74,5	27,7	8	7,2	1,5	3/8-24UNF	3/16	16,8	-20	200	43,6	29,2	1,4	2 1/8
2 3/16	55,563	ES211-35G2T20	100	24	32,5	48,4	20,7	74,5	12	8	7,2	1,1	3/8-24UNF	3/16	16,8	-20	200	43,6	29,2	0,8	2 3/16
		EX211-35G2T20	100	25	55,4	71,3	20,7	74,5	27,7	8	7,2	1,5	3/8-24UNF	3/16	16,8	-20	200	43,6	29,2	1,4	
2 1/4	57,15	ES212-36G2T20	110	24	33,4	49,3	22,3	82	12	8	8	1,1	3/8-24UNF	3/16	16,8	-20	200	52,5	32,8	1,3	2 1/4
		EX212-36G2T20	110	27	61,8	77,7	22,3	82	30,9	8	8,2	1,5	3/8-24UNF	3/16	16,8	-20	200	52,5	32,8	2,0	
2 3/8	60,325	EX212-38G2T20	110	27	61,8	77,7	22,3	82	30,9	8	8,2	1,5	3/8-24UNF	3/16	16,8	-20	200	52,5	32,8	1,8	2 3/8
2 7/16	61,913	ES212-39G2T20	110	24	33,4	49,3	22,3	82	12	8	8	1,1	3/8-24UNF	3/16	16,8	-20	200	52,5	32,8	1,1	2 7/16
		EX212-39G2T20	110	27	61,8	77,7	22,3	82	30,9	8	8,2	1,5	3/8-24UNF	3/16	16,8	-20	200	52,5	32,8	1,8	
2 1/2	63,5	EX213-40G2T20	120	28	68,2	85,7	23,5	86	34,1	8,5	8	1,5	3/8-24UNF	3/16	16,8	-20	200	57,2	40,0	2,5	2 1/2
2 11/16	68,263	EX214-43G2T20	125	30	68,2	85,7	23,5	96,8	34,1	8,5	9	2	3/8-24UNF	3/16	16,8	-20	200	62,0	45,0	2,6	2 11/16
2 3/4	69,85	EX214-44G2T20	125	30	68,2	85,7	23,5	96,8	34,1	8,5	9	2	3/8-24UNF	3/16	16,8	-20	200	62,0	45,0	2,6	2 3/4
2 15/16	74,613	EX215-47G2T20	130	30	74,6	92,1	23,9	102	37,3	8,5	9	2	3/8-24UNF	3/16	16,8	-20	200	66,0	49,5	2,8	2 15/16
3	76,2	EX215-48G2T20	130	30	74,6	92,1	23,9	102	37,3	8,5	9	2	3/8-24UNF	3/16	16,8	-20	200	66,0	49,5	2,7	3
3 3/16	80,963	EX216-51G2T20	140	33	74,6	95,2	27	110	37,3	10,3	10,3	2	3/8-24UNF	3/16	16,8	-20	200	72,5	54,2	3,1	3 3/16
3 1/4	82,55	EX217-52G2T20	150	35	53,2	73,2	27	119	23,4	10	11	2	7/16-20UNF	7/32	27,1	-20	200	83,2	63,8	3,7	3 1/4
3 1/2	88,9	EX218-56G2T20	160	37	55	72,5	24	120	24,5	9,5	12	2	7/16-20UNF	7/32	27,1	-20	200	96,0	71,5	5,0	3 1/2

*Width across flats (hexagon socket)

CHROME STEEL BEARING INSERTS WITH SPHERICAL OUTER RING

SET SCREW TYPES

Basic version

UC2..G2

US2..G2

Medium duty

UCX..G2

Heavy duty

UC3..G2

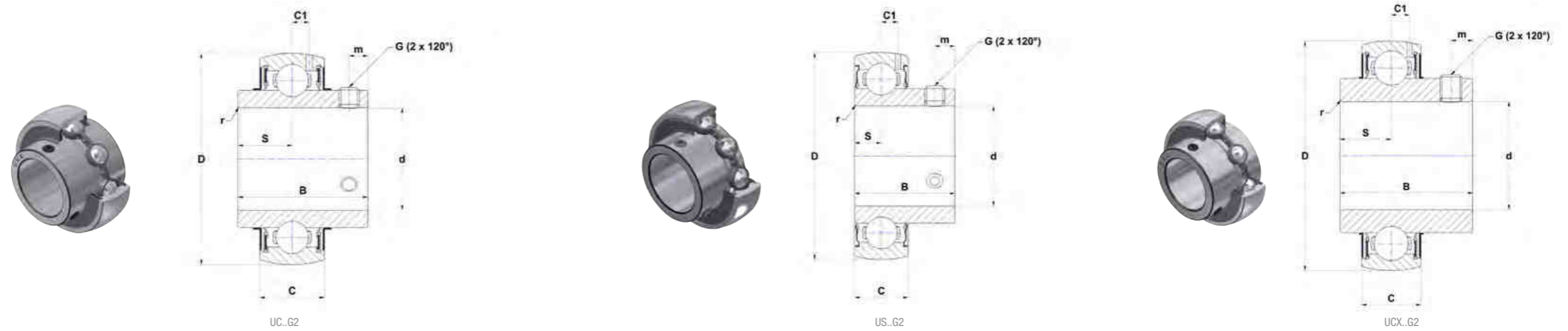

Main dimensions [mm]

d [inch]	d [mm]	Bearing insert	D	C	B	S	m	C1	r min	G	SW*	Set screw torque [Nm]	min Temp [°C]	max Temp [°C]	Dynamic load rating C [kN]	Static load rating C0 [kN]	Weight [kg]	d [inch]
1/2	12,7	UC201-08G2	47	16	31	12,7	4,7	4,4	0,6	1/4-28UNF	1/8	3,7	-20	100	12,8	6,7	0,2	1/2
		US201-08G2	40	12	22	6	4	3,6	0,6	10-32UNF	3/32	3,2	-20	100	9,6	4,8	0,1	
5/8	15,875	UC202-10G2	47	16	31	12,7	4,7	4,4	0,6	1/4-28UNF	1/8	3,7	-20	100	12,8	6,7	0,2	5/8
		US202-10G2	40	12	22	6	4	3,6	0,6	10-32UNF	3/32	3,2	-20	100	9,6	4,8	0,1	
11/16	17,463	UC203-11G2	47	16	31	12,7	4,7	4,4	0,6	1/4-28UNF	1/8	3,7	-20	100	12,8	6,7	0,2	11/16
		US203-11G2	40	12	22	6	4	3,6	0,6	10-32UNF	3/32	3,2	-20	100	9,6	4,8	0,1	
3/4	19,05	UC204-12G2	47	16	31	12,7	4,7	4,4	0,6	1/4-28UNF	1/8	3,7	-20	100	12,8	6,7	0,2	3/4
		US204-12G2	47	14	25	7	5	4	0,6	1/4-28UNF	1/8	3,7	-20	100	12,8	6,7	0,1	
7/8	22,225	UC205-14G2	52	17	34	14,3	5,5	4,3	0,6	1/4-28UNF	1/8	3,7	-20	100	14,0	7,9	0,2	7/8
		UC305-14G2	62	21	38	15	6	6,2	1,5	1/4-28UNF	1/8	3,7	-20	100	22,4	11,5	0,4	
		US205-14G2	52	15	27	7,5	5,5	4,3	0,6	1/4-28UNF	1/8	3,7	-20	100	14,0	7,9	0,2	
15/16	23,813	UC205-15G2	52	17	34	14,3	5,5	4,3	0,6	1/4-28UNF	1/8	3,7	-20	100	14,0	7,9	0,2	15/16
		UC305-15G2	62	21	38	15	6	6,2	1,5	1/4-28UNF	1/8	3,7	-20	100	22,4	11,5	0,4	
		US205-15G2	52	15	27	7,5	5,5	4,3	0,6	1/4-28UNF	1/8	3,7	-20	100	14,0	7,9	0,2	
1	25,4	UC205-16G2	52	17	34	14,3	5,5	4,3	0,6	1/4-28UNF	1/8	3,7	-20	100	14,0	7,9	0,2	1
		UC305-16G2	62	21	38	15	6	6,2	1,5	1/4-28UNF	1/8	3,7	-20	100	22,4	11,5	0,3	
		US205-16G2	52	15	27	7,5	5,5	4,3	0,6	1/4-28UNF	1/8	3,7	-20	100	14,0	7,9	0,2	
1 1/8	28,575	UC206-18G2	62	19	38,1	15,9	5,5	5	0,6	1/4-28UNF	1/8	3,7	-20	100	19,5	11,2	0,3	1 1/8
		UC306-18G2	72	24	43	17	6	6,5	1,5	1/4-28UNF	1/8	3,7	-20	100	27,0	15,2	0,6	
		US206-18G2	62	16	30	8	6	5	0,6	1/4-28UNF	1/8	3,7	-20	100	19,5	11,2	0,3	
1 3/16	30,163	UC206-19G2	62	19	38,1	15,9	5,5	5	0,6	1/4-28UNF	1/8	3,7	-20	100	19,5	11,2	0,3	1 3/16
		UC306-19G2	72	24	43	17	6	6,5	1,5	1/4-28UNF	1/8	3,7	-20	100	27,0	15,2	0,6	
		US206-19G2	62	16	30	8	6	5	0,6	1/4-28UNF	1/8	3,7	-20	100	19,5	11,2	0,3	
1 1/4	31,75	UC206-20G2	62	19	38,1	15,9	5,5	5	0,6	1/4-28UNF	1/8	3,7	-20	100	19,5	11,2	0,3	1 1/4
		UC207-20G2	72	20	42,9	17,5	6,5	5,8	1,1	5/16-24UNF	5/32	8	-20	100	25,7	15,2	0,5	
		UC307-20G2	80	25	48	19	8	7,2	2	5/16-24UNF	5/32	8	-20	100	33,5	19,2	0,8	
		US206-20G2	62	16	30	8	6	5	0,6	1/4-28UNF	1/8	3,7	-20	100	19,5	11,2	0,2	
1 5/16	33,338	UC207-21G2	72	20	42,9	17,5	6,5	5,8	1,1	5/16-24UNF	5/32	8	-20	100	25,7	15,2	0,5	1 5/16
1 3/8	34,925	UC207-22G2	72	20	42,9	17,5	6,5	5,8	1,1	5/16-24UNF	5/32	8	-20	100	25,7	15,2	0,5	1 3/8
		UC307-22G2	80	25	48	19	8	7,2	2	5/16-24UNF	5/32	8	-20	100	33,5	19,2	0,7	
		US207-22G2	72	17	32	8,5	6,5	5,7	0,6	5/16-24UNF	5/32	8	-20	100	25,7	15,2	0,4	
1 7/16	36,513	UC207-23G2	72	20	42,9	17,5	6,5	5,8	1,1	5/16-24UNF	5/32	8	-20	100	25,7	15,2	0,5	1 7/16
		UC307-23G2	80	25	48	19	8	7,2	2	5/16-24UNF	5/32	8	-20	100	33,5	19,2	0,7	
		US207-23G2	72	17	32	8,5	6,5	5,7	0,6	5/16-24UNF	5/32	8	-20	100	25,7	15,2	0,4	
1 1/2	38,1	UC208-24G2	80	21	49,2	19	8	6,3	1,1	5/16-24UNF	5/32	8	-20	100	29,6	18,2	0,7	1 1/2
		UC308-24G2	90	28	52	19	10	8,5	2	3/8-24UNF	3/16	16,8	-20	100	40,6	24,0	1,0	
		UCX08-24G2	85	22	49,2	19	8	6,8	1,2	5/16-24UNF	5/32	8	-20	100	31,9	20,8	0,9	
		US208-24G2	80	18	34	9	7	6,2	1,1	5/16-24UNF	5/32	8	-20	100	29,6	18,2	0,6	
1 9/16	39,688	UC208-25G2	80	21	49,2	19	8	6,3	1,1	5/16-24UNF	5/32	8	-20	100	29,6	18,2	0,7	1 9/16
1 5/8	41,275	UC209-26G2	85	22	49,2	19	8	6,8	1,1	5/16-24UNF	5/32	8	-20	100	31,9	20,8	0,8	1 5/8
		UC309-26G2	100	30	57	22	10	9	2	3/8-24UNF	3/16	16,8	-20	100	53,0	31,8	1,4	
		US209-26G2	85	19	41,2	10,2	8,2	6,5	1,1	5/16-24UNF	5/32	8	-20	100	31,9	20,8	0,8	
1 11/16	42,863	UC209-27G2	85	22	49,2	19	8	6,8	1,1	5/16-24UNF	5/32	8	-20	100	31,9	20,8	0,7	1 11/16
		UC309-27G2	100	30	57	22	10	9	2	3/8-24UNF	3/16	16,8	-20	100	53,0	31,8	1,3	
		US209-27G2	85	19	41,2	10,2	8,2	6,5	1,1	5/16-24UNF	5/32	8	-20	100	31,9	20,8	0,7	

*Width across flats (hexagon socket)

CHROME STEEL BEARING INSERTS WITH SPHERICAL OUTER RING

SET SCREW TYPES

Basic version

UC2..G2

US2..G2

Medium duty

UCX..G2

Heavy duty

UC3..G2

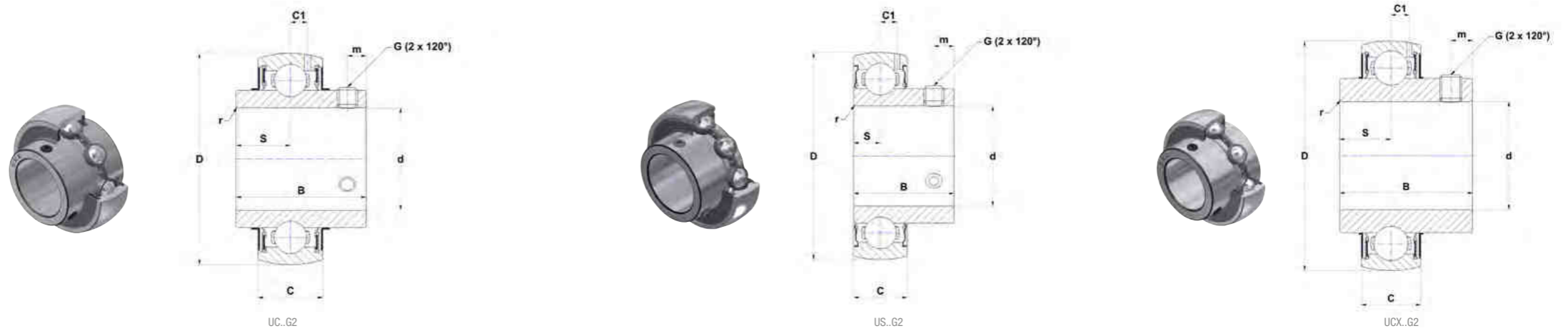

Main dimensions [mm]

d [inch]	d [mm]	Bearing insert	D	C	B	S	m	C1	r min	G	SW*	Set screw torque [Nm]	min Temp [°C]	max Temp [°C]	Dynamic load rating C [kN]	Static load rating C0 [kN]	Weight [kg]	d [inch]
1 3/4	44,45	UC209-28G2	85	22	49,2	19	8	6,8	1,1	5/16-24UNF	5/32	8	-20	100	31,9	20,8	0,7	1 3/4
		UC309-28G2	100	30	57	22	10	9	2	3/8-24UNF	3/16	16,8	-20	100	53,0	31,8	1,3	
		UCX09-28G2	90	23	51,6	19	9	6,5	1,2	3/8-24UNF	3/16	16,8	-20	100	35,1	23,2	1,0	
		US209-28G2	85	19	41,2	10,2	8,2	6,5	1,1	5/16-24UNF	5/32	8	-20	100	31,9	20,8	0,7	
1 7/8	47,625	UC210-30G2	90	23	51,6	19	9	6,5	1,1	3/8-24UNF	3/16	16,8	-20	100	35,1	23,2	0,9	1 7/8
		UC310-30G2	110	32	61	22	12	9,9	2	7/16-20UNF	7/32	27,1	-20	100	62,0	37,8	1,7	
		US210-30G2	90	20	43,5	10,9	9,2	6,5	1,1	5/16-24UNF	5/32	8	-20	100	35,1	23,2	0,8	
1 15/16	49,213	UC210-31G2	90	23	51,6	19	9	6,5	1,1	3/8-24UNF	3/16	16,8	-20	100	35,1	23,2	0,8	1 15/16
		UC310-31G2	110	32	61	22	12	9,9	2	7/16-20UNF	7/32	27,1	-20	100	62,0	37,8	1,7	
		US210-31G2	90	20	43,5	10,9	9,2	6,5	1,1	5/16-24UNF	5/32	8	-20	100	35,1	23,2	0,8	
2	50,8	UC211-32G2	100	25	55,6	22,2	9	7,2	1,1	3/8-24UNF	3/16	16,8	-20	100	43,6	29,2	1,3	2
		UC311-32G2	120	34	66	25	12	10,6	2	7/16-20UNF	7/32	27,1	-20	100	71,5	44,8	2,1	
		UCX10-32G2	100	25	55,6	22,2	9	7,2	1,2	3/8-24UNF	3/16	16,8	-20	100	43,6	29,2	1,2	
		US211-32G2	100	23	45,3	11,8	9,8	7,2	1,1	5/16-24UNF	5/32	8	-20	100	43,6	29,2	1,1	
2 1/8	53,975	UC211-34G2	100	25	55,6	22,2	9	7,2	1,1	3/8-24UNF	3/16	16,8	-20	100	43,6	29,2	1,2	2 1/8
2 3/16	55,563	UC211-35G2	100	25	55,6	22,2	9	7,2	1,1	3/8-24UNF	3/16	16,8	-20	100	43,6	29,2	1,1	2 3/16
		UC311-35G2	120	34	66	25	12	10,6	2	7/16-20UNF	7/32	27,1	-20	100	71,5	44,8	1,9	
		US211-35G2	100	23	45,3	11,8	9,8	7,2	1,1	5/16-24UNF	5/32	8	-20	100	43,6	29,2	1,1	
2 1/4	57,15	UC212-36G2	110	27	65,1	25,4	10,5	8,2	1,1	3/8-24UNF	3/16	16,8	-20	100	52,5	32,8	1,7	2 1/4
		UC312-36G2	130	36	71	26	12	11,3	2	7/16-20UNF	7/32	27,1	-20	100	81,6	51,8	2,7	
		US212-36G2	110	24	53,7	14,9	9,8	8	1,1	3/8-24UNF	3/16	16,8	-20	100	52,5	32,8	1,3	
2 3/8	60,325	UC212-38G2	110	27	65,1	25,4	10,5	8,2	1,1	3/8-24UNF	3/16	16,8	-20	100	52,5	32,8	1,5	2 3/8
2 7/16	61,913	UC212-39G2	110	27	65,1	25,4	10,5	8,2	1,1	3/8-24UNF	3/16	16,8	-20	100	52,5	32,8	1,5	2 7/16
		UC312-39G2	130	36	71	26	12	11,3	2	7/16-20UNF	7/32	27,1	-20	100	81,6	51,8	2,5	
		US212-39G2	110	24	53,7	14,9	9,8	8	1,1	3/8-24UNF	3/16	16,8	-20	100	52,5	32,8	1,2	
2 1/2	63,5	UC213-40G2	120	28	65,1	25,4	12	8	1,5	3/8-24UNF	3/16	16,8	-20	100	57,2	40,0	1,9	2 1/2
		UC313-40G2	140	38	75	30	12	12,1	2	7/16-20UNF	7/32	27,1	-20	100	93,9	60,5	3,3	
		UCX13-40G2	130	30	77,8	33,3	12	9	2	7/16-20UNF	7/32	27,1	-20	100	66,0	49,5	3,0	
2 11/16	68,263	UC214-43G2	125	30	74,6	30,2	12	9	2	7/16-20UNF	7/32	27,1	-20	100	62,0	45,0	2,0	2 11/16
		UC314-43G2	150	40	78	33	12	12,8	2,5	7/16-20UNF	7/32	27,1	-20	100	104,3	68,0	4,0	
2 3/4	69,85	UC214-44G2	125	30	74,6	30,2	12	9	2	7/16-20UNF	7/32	27,1	-20	100	62,0	45,0	2,1	2 3/4
		UC314-44G2	150	40	78	33	12	12,8	2,5	7/16-20UNF	7/32	27,1	-20	100	104,3	68,0	4,0	
2 15/16	74,613	UC215-47G2	130	30	77,8	33,3	12	9	2	7/16-20UNF	7/32	27,1	-20	100	66,0	49,5	2,3	2 15/16
		UC315-47G2	160	42	82	32	14	13,5	2,5	1/2-20UNF	1/4	33,9	-20	100	113,4	76,8	4,3	
3	76,2	UC215-48G2	130	30	77,8	33,3	12	9	2	7/16-20UNF	7/32	27,1	-20	100	66,0	49,5	2,1	3
		UC315-48G2	160	42	82	32	14	13,5	2,5	1/2-20UNF	1/4	33,9	-20	100	113,4	76,8	4,2	
		UCX15-48G2	140	33	82,6	33,3	14	10,3	2,5	7/16-20UNF	7/32	27,1	-20	100	72,5	54,2	3,1	
3 3/16	80,963	UC216-51G2	140	33	82,6	33,3	14	10,3	2	7/16-20UNF	7/32	27,1	-20	100	72,5	54,2	2,8	3 3/16
3 1/4	82,55	UC217-52G2	150	35	85,7	34,1	14	11	2	7/16-20UNF	7/32	27,1	-20	100	83,2	63,8	3,3	3 1/4
		UC317-52G2	180	46	96	40	16	15,5	3	5/8-18UNF	5/16	54,5	-20	100	132,6	96,5	6,8	
3 1/2	88,9	UC218-56G2	160	37	96	39,7	14	12	2	1/2-20UNF	1/4	33,9	-20	100	96,0	71,5	4,6	3 1/2
		UC318-56G2	190	48	96	40	16	16,5	3,5	5/8-18UNF	5/16	54,5	-20	100	143,0	108,0	8,0	
4	101,6	UC320-64G2	215	54	108	42	18	19	3,5	5/8-18UNF	5/16	54,5	-20	100	171,6	140,0	11,0	4

*Width across flats (hexagon socket)

CHROME STEEL BEARING INSERTS WITH SPHERICAL OUTER RING

SET SCREW TYPES

Triple lip seal version L3
UC2..G2L3

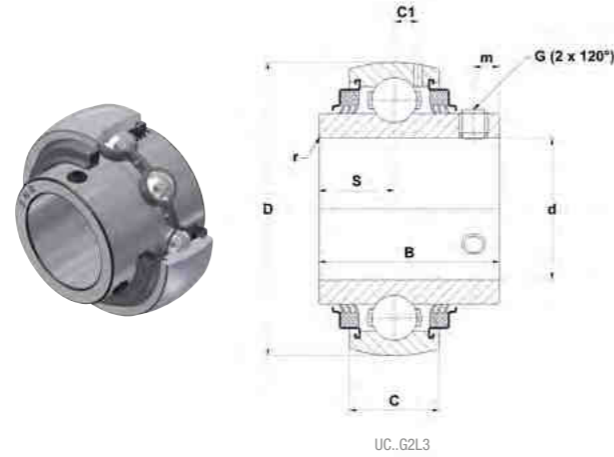

Main dimensions [mm]

d [inch]	d [mm]	Bearing insert	D	C	B	S	m	C1	r min	G	SW*	Set screw torque [Nm]	min Temp [°C]	max Temp [°C]	Dynamic load rating C [kN]	Static load rating C0 [kN]	Weight [kg]	d [inch]
1/2	12,7	UC201-08G2L3	47	16	31	12,7	4,7	4,4	0,6	1/4-28UNF	1/8	3,7	-20	100	12,8	6,7	0,2	1/2
5/8	15,875	UC202-10G2L3	47	16	31	12,7	4,7	4,4	0,6	1/4-28UNF	1/8	3,7	-20	100	12,8	6,7	0,2	5/8
11/16	17,463	UC203-11G2L3	47	16	31	12,7	4,7	4,4	0,6	1/4-28UNF	1/8	3,7	-20	100	12,8	6,7	0,2	11/16
3/4	19,05	UC204-12G2L3	47	16	31	12,7	4,7	4,4	0,6	1/4-28UNF	1/8	3,7	-20	100	12,8	6,7	0,2	3/4
7/8	22,225	UC205-14G2L3	52	17	34	14,3	5,5	4,3	0,6	1/4-28UNF	1/8	3,7	-20	100	14,0	7,9	0,2	7/8
15/16	23,813	UC205-15G2L3	52	17	34	14,3	5,5	4,3	0,6	1/4-28UNF	1/8	3,7	-20	100	14,0	7,9	0,2	15/16
1	25,4	UC205-16G2L3	52	17	34	14,3	5,5	4,3	0,6	1/4-28UNF	1/8	3,7	-20	100	14,0	7,9	0,2	1
1 1/8	28,575	UC206-18G2L3	62	19	38,1	15,9	5,5	5	0,6	1/4-28UNF	1/8	3,7	-20	100	19,5	11,2	0,3	1 1/8
1 3/16	30,163	UC206-19G2L3	62	19	38,1	15,9	5,5	5	0,6	1/4-28UNF	1/8	3,7	-20	100	19,5	11,2	0,3	1 3/16
1 1/4	31,75	UC206-20G2L3	62	19	38,1	15,9	5,5	5	0,6	1/4-28UNF	1/8	3,7	-20	100	19,5	11,2	0,3	1 1/4
1 5/16	33,338	UC207-20G2L3	72	20	42,9	17,5	6,5	5,8	1,1	5/16-24UNF	5/32	8	-20	100	25,7	15,2	0,5	1 5/16
1 3/8	34,925	UC207-21G2L3	72	20	42,9	17,5	6,5	5,8	1,1	5/16-24UNF	5/32	8	-20	100	25,7	15,2	0,5	1 3/8
1 7/16	36,513	UC207-22G2L3	72	20	42,9	17,5	6,5	5,8	1,1	5/16-24UNF	5/32	8	-20	100	25,7	15,2	0,5	1 7/16
1 1/2	38,1	UC207-23G2L3	72	20	42,9	17,5	6,5	5,8	1,1	5/16-24UNF	5/32	8	-20	100	25,7	15,2	0,5	1 1/2
1 9/16	39,688	UC208-24G2L3	80	21	49,2	19	8	6,3	1,1	5/16-24UNF	5/32	8	-20	100	29,6	18,2	0,7	1 9/16
1 5/8	41,275	UC208-25G2L3	80	21	49,2	19	8	6,3	1,1	5/16-24UNF	5/32	8	-20	100	29,6	18,2	0,7	1 5/8
1 11/16	42,863	UC209-26G2L3	85	22	49,2	19	8	6,8	1,1	5/16-24UNF	5/32	8	-20	100	31,9	20,8	0,8	1 11/16
1 3/4	44,45	UC209-27G2L3	85	22	49,2	19	8	6,8	1,1	5/16-24UNF	5/32	8	-20	100	31,9	20,8	0,7	1 3/4
1 7/8	47,625	UC209-28G2L3	85	22	49,2	19	8	6,8	1,1	5/16-24UNF	5/32	8	-20	100	31,9	20,8	0,7	1 7/8
1 15/16	49,213	UC210-30G2L3	90	23	51,6	19	9	6,5	1,1	3/8-24UNF	3/16	16,8	-20	100	35,1	23,2	0,9	1 15/16
2	50,8	UC210-31G2L3	90	23	51,6	19	9	6,5	1,1	3/8-24UNF	3/16	16,8	-20	100	35,1	23,2	0,8	2
2 1/8	53,975	UC211-32G2L3	100	25	55,6	22,2	9	7,2	1,1	3/8-24UNF	3/16	16,8	-20	100	43,6	29,2	1,3	2 1/8
2 3/16	55,563	UC211-34G2L3	100	25	55,6	22,2	9	7,2	1,1	3/8-24UNF	3/16	16,8	-20	100	43,6	29,2	1,2	2 3/16
2 1/4	57,15	UC211-35G2L3	100	25	55,6	22,2	9	7,2	1,1	3/8-24UNF	3/16	16,8	-20	100	43,6	29,2	1,1	2 1/4
2 3/8	60,325	UC212-36G2L3	110	27	65,1	25,4	10,5	8,2	1,1	3/8-24UNF	3/16	16,8	-20	100	52,5	32,8	1,7	2 3/8
2 7/16	61,913	UC212-38G2L3	110	27	65,1	25,4	10,5	8,2	1,1	3/8-24UNF	3/16	16,8	-20	100	52,5	32,8	1,5	2 7/16
2 1/2	63,5	UC212-39G2L3	110	27	65,1	25,4	10,5	8,2	1,1	3/8-24UNF	3/16	16,8	-20	100	52,5	32,8	1,5	2 1/2
2 11/16	68,263	UC213-40G2L3	120	28	65,1	25,4	12	8	1,5	3/8-24UNF	3/16	16,8	-20	100	57,2	40,0	1,9	2 11/16
2 3/4	69,85	UC213-43G2L3	125	30	74,6	30,2	12	9	2	7/16-20UNF	7/32	27,1	-20	100	62,0	45,0	2,0	2 3/4
2 15/16	74,613	UC214-44G2L3	125	30	74,6	30,2	12	9	2	7/16-20UNF	7/32	27,1	-20	100	62,0	45,0	2,1	2 15/16
3	76,2	UC215-47G2L3	130	30	77,8	33,3	12	9	2	7/16-20UNF	7/32	27,1	-20	100	66,0	49,5	2,3	3
3 3/16	80,963	UC215-48G2L3	130	30	77,8	33,3	12	9	2	7/16-20UNF	7/32	27,1	-20	100	66,0	49,5	2,1	3 3/16
3 1/4	82,55	UC216-51G2L3	140	33	82,6	33,3	14	10,3	2	7/16-20UNF	7/32	27,1	-20	100	72,5	54,2	2,8	3 1/4
3 1/2	88,9	UC217-52G2L3	150	35	85,7	34,1	14	11	2	7/16-20UNF	7/32	27,1	-20	100	83,2	63,8	3,3	3 1/2
3 1/2	88,9	UC218-56G2L3	160	37	96	39,7	14	12	2	1/2-20UNF	1/4	33,9	-20	100	96,0	71,5	4,6	3 1/2

*Width across flats (hexagon socket)

CHROME STEEL BEARING INSERTS WITH SPHERICAL OUTER RING

SET SCREW TYPES

Low temperature version T04

UC2..G2T04

UC3..G2T04

US2..G2T04



Main dimensions [mm]

d [inch]	d [mm]	Bearing insert	D	C	B	S	m	C1	r min	G	SW*	Set screw torque [Nm]	min Temp [°C]	max Temp [°C]	Dynamic load rating C [kN]	Static load rating C0 [kN]	Weight [kg]	d [inch]
1/2	12,7	UC201-08G2T04	47	16	31	12,7	4,7	4,4	0,6	1/4-28UNF	1/8	3,7	-40	100	12,8	6,7	0,2	1/2
		US201-08G2T04	40	12	22	6	4	3,6	0,6	10-32UNF	3/32	3,2	-40	100	9,6	4,8	0,1	
5/8	15,875	UC202-10G2T04	47	16	31	12,7	4,7	4,4	0,6	1/4-28UNF	1/8	3,7	-40	100	12,8	6,7	0,2	5/8
		US202-10G2T04	40	12	22	6	4	3,6	0,6	10-32UNF	3/32	3,2	-40	100	9,6	4,8	0,1	
11/16	17,463	UC203-11G2T04	47	16	31	12,7	4,7	4,4	0,6	1/4-28UNF	1/8	3,7	-40	100	12,8	6,7	0,2	11/16
		US203-11G2T04	40	12	22	6	4	3,6	0,6	10-32UNF	3/32	3,2	-40	100	9,6	4,8	0,1	
3/4	19,05	UC204-12G2T04	47	16	31	12,7	4,7	4,4	0,6	1/4-28UNF	1/8	3,7	-40	100	12,8	6,7	0,2	3/4
		US204-12G2T04	47	14	25	7	5	4	0,6	1/4-28UNF	1/8	3,7	-40	100	12,8	6,7	0,1	
7/8	22,225	UC205-14G2T04	52	17	34	14,3	5,5	4,3	0,6	1/4-28UNF	1/8	3,7	-40	100	14,0	7,9	0,2	7/8
		UC305-14G2T04	62	21	38	15	6	6,2	1,5	1/4-28UNF	1/8	3,7	-40	100	22,4	11,5	0,4	
		US205-14G2T04	52	15	27	7,5	5,5	4,3	0,6	1/4-28UNF	1/8	3,7	-40	100	14,0	7,9	0,2	
15/16	23,813	UC205-15G2T04	52	17	34	14,3	5,5	4,3	0,6	1/4-28UNF	1/8	3,7	-40	100	14,0	7,9	0,2	15/16
		UC305-15G2T04	62	21	38	15	6	6,2	1,5	1/4-28UNF	1/8	3,7	-40	100	22,4	11,5	0,4	
		US205-15G2T04	52	15	27	7,5	5,5	4,3	0,6	1/4-28UNF	1/8	3,7	-40	100	14,0	7,9	0,2	
1	25,4	UC205-16G2T04	52	17	34	14,3	5,5	4,3	0,6	1/4-28UNF	1/8	3,7	-40	100	14,0	7,9	0,2	1
		UC305-16G2T04	62	21	38	15	6	6,2	1,5	1/4-28UNF	1/8	3,7	-40	100	22,4	11,5	0,3	
		US205-16G2T04	52	15	27	7,5	5,5	4,3	0,6	1/4-28UNF	1/8	3,7	-40	100	14,0	7,9	0,2	
1 1/8	28,575	UC206-18G2T04	62	19	38,1	15,9	5,5	5	0,6	1/4-28UNF	1/8	3,7	-40	100	19,5	11,2	0,3	1 1/8
		UC306-18G2T04	72	24	43	17	6	6,5	1,5	1/4-28UNF	1/8	3,7	-40	100	27,0	15,2	0,6	
		US206-18G2T04	62	16	30	8	6	5	0,6	1/4-28UNF	1/8	3,7	-40	100	19,5	11,2	0,3	
1 3/16	30,163	UC206-19G2T04	62	19	38,1	15,9	5,5	5	0,6	1/4-28UNF	1/8	3,7	-40	100	19,5	11,2	0,3	1 3/16
		UC306-19G2T04	72	24	43	17	6	6,5	1,5	1/4-28UNF	1/8	3,7	-40	100	27,0	15,2	0,6	
		US206-19G2T04	62	16	30	8	6	5	0,6	1/4-28UNF	1/8	3,7	-40	100	19,5	11,2	0,3	
1 1/4	31,75	UC206-20G2T04	62	19	38,1	15,9	5,5	5	0,6	1/4-28UNF	1/8	3,7	-40	100	19,5	11,2	0,3	1 1/4
		UC207-20G2T04	72	20	42,9	17,5	6,5	5,8	1,1	5/16-24UNF	5/32	8	-40	100	25,7	15,2	0,5	
		UC307-20G2T04	80	25	48	19	8	7,2	2	5/16-24UNF	5/32	8	-40	100	33,5	19,2	0,8	
		US206-20G2T04	62	16	30	8	6	5	0,6	1/4-28UNF	1/8	3,7	-40	100	19,5	11,2	0,2	
1 5/16	33,338	UC207-21G2T04	72	20	42,9	17,5	6,5	5,8	1,1	5/16-24UNF	5/32	8	-40	100	25,7	15,2	0,5	1 5/16
		UC207-22G2T04	72	20	42,9	17,5	6,5	5,8	1,1	5/16-24UNF	5/32	8	-40	100	25,7	15,2	0,5	
1 3/8	34,925	UC307-22G2T04	80	25	48	19	8	7,2	2	5/16-24UNF	5/32	8	-40	100	33,5	19,2	0,7	1 3/8
		US207-22G2T04	72	17	32	8,5	6,5	5,7	0,6	5/16-24UNF	5/32	8	-40	100	25,7	15,2	0,4	
		UC207-23G2T04	72	20	42,9	17,5	6,5	5,8	1,1	5/16-24UNF	5/32	8	-40	100	25,7	15,2	0,5	
1 7/16	36,513	UC307-23G2T04	80	25	48	19	8	7,2	2	5/16-24UNF	5/32	8	-40	100	33,5	19,2	0,7	1 7/16
		US207-23G2T04	72	17	32	8,5	6,5	5,7	0,6	5/16-24UNF	5/32	8	-40	100	25,7	15,2	0,4	
		UC208-24G2T04	80	21	49,2	19	8	6,3	1,1	5/16-24UNF	5/32	8	-40	100	29,6	18,2	0,7	
1 1/2	38,1	UC308-24G2T04	90	28	52	19	10	8,5	2	3/8-24UNF	3/16	16,8	-40	100	40,6	24,0	1,0	1 1/2
		US208-24G2T04	80	18	34	9	7	6,2	1,1	5/16-24UNF	5/32	8	-40	100	29,6	18,2	0,6	
		UC208-25G2T04	80	21	49,2	19	8	6,3	1,1	5/16-24UNF	5/32	8	-40	100	29,6	18,2	0,7	
1 9/16	39,688	UC208-25G2T04	80	21	49,2	19	8	6,3	1,1	5/16-24UNF	5/32	8	-40	100	29,6	18,2	0,7	1 9/16
		UC209-26G2T04	85	22	49,2	19	8	6,8	1,1	5/16-24UNF	5/32	8	-40	100	31,9	20,8	0,8	
1 5/8	41,275	UC309-26G2T04	100	30	57	22	10	9	2	3/8-24UNF	3/16	16,8	-40	100	53,0	31,8	1,4	1 5/8
		US209-26G2T04	85	19	41,2	10,2	8,2	6,5	1,1	5/16-24UNF	5/32	8	-40	100	31,9	20,8	0,8	
		UC209-27G2T04	85	22	49,2	19	8	6,8	1,1	5/16-24UNF	5/32	8	-40	100	31,9	20,8	0,7	
1 11/16	42,863	UC309-27G2T04	100	30	57	22	10	9	2	3/8-24UNF	3/16	16,8	-40	100	53,0	31,8	1,3	1 11/16
		US209-27G2T04	85	19	41,2	10,2	8,2	6,5	1,1	5/16-24UNF	5/32	8	-40	100	31,9	20,8	0,7	

*Width across flats (hexagon socket)

CHROME STEEL BEARING INSERTS WITH SPHERICAL OUTER RING

SET SCREW TYPES

Low temperature version T04

UC2..G2T04

UC3..G2T04

US2..G2T04

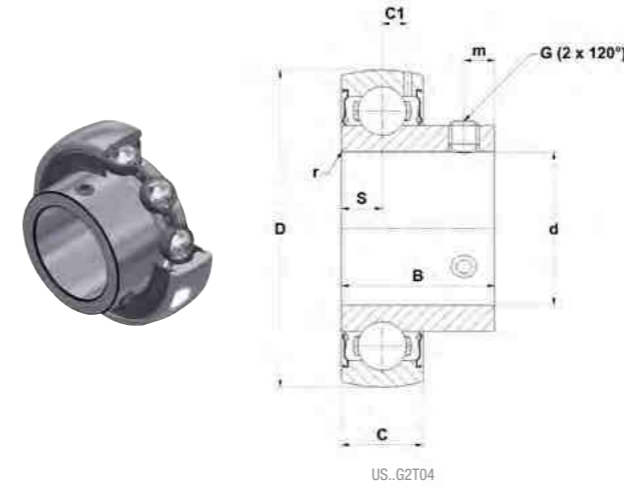
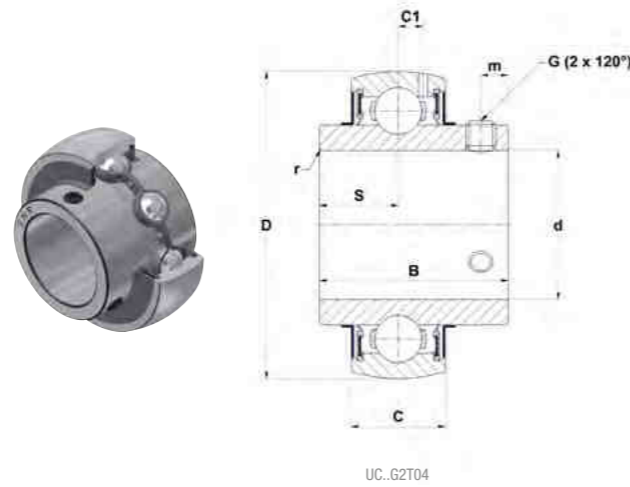

Main dimensions [mm]

d [inch]	d [mm]	Bearing insert	D	C	B	S	m	C1	r min	G	SW*	Set screw torque [Nm]	min Temp [°C]	max Temp [°C]	Dynamic load rating C [kN]	Static load rating C0 [kN]	Weight [kg]	d [inch]
1 3/4	44,45	UC209-28G2T04	85	22	49,2	19	8	6,8	1,1	5/16-24UNF	5/32	8	-40	100	31,9	20,8	0,7	1 3/4
		UC309-28G2T04	100	30	57	22	10	9	2	3/8-24UNF	3/16	16,8	-40	100	53,0	31,8	1,3	
		US209-28G2T04	85	19	41,2	10,2	8,2	6,5	1,1	5/16-24UNF	5/32	8	-40	100	31,9	20,8	0,7	
1 7/8	47,625	UC210-30G2T04	90	23	51,6	19	9	6,5	1,1	3/8-24UNF	3/16	16,8	-40	100	35,1	23,2	0,9	1 7/8
		UC310-30G2T04	110	32	61	22	12	9,9	2	7/16-20UNF	7/32	27,1	-40	100	62,0	37,8	1,7	
		US210-30G2T04	90	20	43,5	10,9	9,2	6,5	1,1	5/16-24UNF	5/32	8	-40	100	35,1	23,2	0,8	
1 15/16	49,213	UC210-31G2T04	90	23	51,6	19	9	6,5	1,1	3/8-24UNF	3/16	16,8	-40	100	35,1	23,2	0,8	1 15/16
		UC310-31G2T04	110	32	61	22	12	9,9	2	7/16-20UNF	7/32	27,1	-40	100	62,0	37,8	1,7	
		US210-31G2T04	90	20	43,5	10,9	9,2	6,5	1,1	5/16-24UNF	5/32	8	-40	100	35,1	23,2	0,8	
2	50,8	UC211-32G2T04	100	25	55,6	22,2	9	7,2	1,1	3/8-24UNF	3/16	16,8	-40	100	43,6	29,2	1,3	2
		UC311-32G2T04	120	34	66	25	12	10,6	2	7/16-20UNF	7/32	27,1	-40	100	71,5	44,8	2,1	
		US211-32G2T04	100	23	45,3	11,8	9,8	7,2	1,1	5/16-24UNF	5/32	8	-40	100	43,6	29,2	1,1	
2 1/8	53,975	UC211-34G2T04	100	25	55,6	22,2	9	7,2	1,1	3/8-24UNF	3/16	16,8	-40	100	43,6	29,2	1,2	2 1/8
2 3/16	55,563	UC211-35G2T04	100	25	55,6	22,2	9	7,2	1,1	3/8-24UNF	3/16	16,8	-40	100	43,6	29,2	1,1	2 3/16
		UC311-35G2T04	120	34	66	25	12	10,6	2	7/16-20UNF	7/32	27,1	-40	100	71,5	44,8	1,9	
		US211-35G2T04	100	23	45,3	11,8	9,8	7,2	1,1	5/16-24UNF	5/32	8	-40	100	43,6	29,2	1,1	
2 1/4	57,15	UC212-36G2T04	110	27	65,1	25,4	10,5	8,2	1,1	3/8-24UNF	3/16	16,8	-40	100	52,5	32,8	1,7	2 1/4
		UC312-36G2T04	130	36	71	26	12	11,3	2	7/16-20UNF	7/32	27,1	-40	100	81,6	51,8	2,7	
		US212-36G2T04	110	24	53,7	14,9	9,8	8	1,1	3/8-24UNF	3/16	16,8	-40	100	52,5	32,8	1,3	
2 3/8	60,325	UC212-38G2T04	110	27	65,1	25,4	10,5	8,2	1,1	3/8-24UNF	3/16	16,8	-40	100	52,5	32,8	1,5	2 3/8
2 7/16	61,913	UC212-39G2T04	110	27	65,1	25,4	10,5	8,2	1,1	3/8-24UNF	3/16	16,8	-40	100	52,5	32,8	1,5	2 7/16
		UC312-39G2T04	130	36	71	26	12	11,3	2	7/16-20UNF	7/32	27,1	-40	100	81,6	51,8	2,5	
		US212-39G2T04	110	24	53,7	14,9	9,8	8	1,1	3/8-24UNF	3/16	16,8	-40	100	52,5	32,8	1,2	
2 1/2	63,5	UC213-40G2T04	120	28	65,1	25,4	12	8	1,5	3/8-24UNF	3/16	16,8	-40	100	57,2	40,0	1,9	2 1/2
		UC313-40G2T04	140	38	75	30	12	12,1	2	7/16-20UNF	7/32	27,1	-40	100	93,9	60,5	3,3	
2 11/16	68,263	UC214-43G2T04	125	30	74,6	30,2	12	9	2	7/16-20UNF	7/32	27,1	-40	100	62,0	45,0	2,0	2 11/16
		UC314-43G2T04	150	40	78	33	12	12,8	2,5	7/16-20UNF	7/32	27,1	-40	100	104,3	68,0	4,0	
2 3/4	69,85	UC214-44G2T04	125	30	74,6	30,2	12	9	2	7/16-20UNF	7/32	27,1	-40	100	62,0	45,0	2,1	2 3/4
		UC314-44G2T04	150	40	78	33	12	12,8	2,5	7/16-20UNF	7/32	27,1	-40	100	104,3	68,0	4,0	
2 15/16	74,613	UC215-47G2T04	130	30	77,8	33,3	12	9	2	7/16-20UNF	7/32	27,1	-40	100	66,0	49,5	2,3	2 15/16
		UC315-47G2T04	160	42	82	32	14	13,5	2,5	1/2-20UNF	1/4	33,9	-40	100	113,4	76,8	4,3	
3	76,2	UC215-48G2T04	130	30	77,8	33,3	12	9	2	7/16-20UNF	7/32	27,1	-40	100	66,0	49,5	2,1	3
		UC315-48G2T04	160	42	82	32	14	13,5	2,5	1/2-20UNF	1/4	33,9	-40	100	113,4	76,8	4,2	
3 3/16	80,963	UC216-51G2T04	140	33	82,6	33,3	14	10,3	2	7/16-20UNF	7/32	27,1	-40	100	72,5	54,2	2,8	3 3/16
3 1/4	82,55	UC217-52G2T04	150	35	85,7	34,1	14	11	2	7/16-20UNF	7/32	27,1	-40	100	83,2	63,8	3,3	3 1/4
		UC317-52G2T04	180	46	96	40	16	15,5	3	5/8-18UNF	5/16	54,5	-40	100	132,6	96,5	6,8	
3 1/2	88,9	UC218-56G2T04	160	37	96	39,7	14	12	2	1/2-20UNF	1/4	33,9	-40	100	96,0	71,5	4,6	3 1/2
		UC318-56G2T04	190	48	96	40	16	16,5	3,5	5/8-18UNF	5/16	54,5	-40	100	143,0	108,0	8,0	
4	101,6	UC320-64G2T04	215	54	108	42	18	19	3,5	5/8-18UNF	5/16	54,5	-40	100	171,6	140,0	11,0	4

*Width across flats (hexagon socket)

CHROME STEEL BEARING INSERTS WITH SPHERICAL OUTER RING

SET SCREW TYPES

High temperature version T20

UC2..G2T20

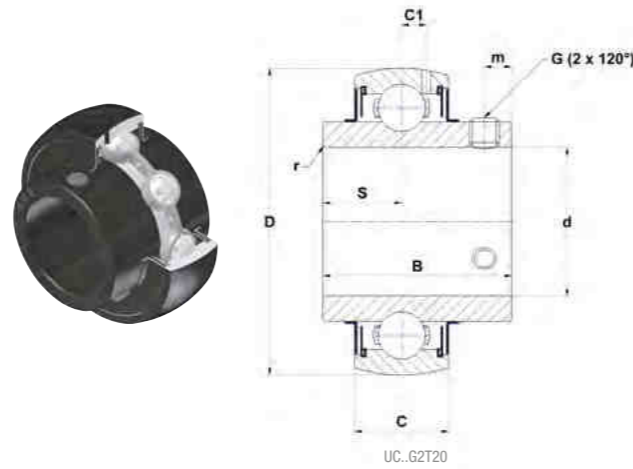

Main dimensions [mm]

d [inch]	d [mm]	Bearing insert	D	C	B	S	m	C1	r min	G	SW*	Set screw torque [Nm]	min Temp [°C]	max Temp [°C]	Dynamic load rating C [kN]	Static load rating C0 [kN]	Weight [kg]	d [inch]
1/2	12,7	UC201-08G2T20	47	16	31	12,7	4,7	4,4	0,6	1/4-28UNF	1/8	3,7	-20	200	12,8	6,7	0,2	1/2
5/8	15,875	UC202-10G2T20	47	16	31	12,7	4,7	4,4	0,6	1/4-28UNF	1/8	3,7	-20	200	12,8	6,7	0,2	5/8
11/16	17,463	UC203-11G2T20	47	16	31	12,7	4,7	4,4	0,6	1/4-28UNF	1/8	3,7	-20	200	12,8	6,7	0,2	11/16
3/4	19,05	UC204-12G2T20	47	16	31	12,7	4,7	4,4	0,6	1/4-28UNF	1/8	3,7	-20	200	12,8	6,7	0,2	3/4
7/8	22,225	UC205-14G2T20	52	17	34	14,3	5,5	4,3	0,6	1/4-28UNF	1/8	3,7	-20	200	14,0	7,9	0,2	7/8
15/16	23,813	UC205-15G2T20	52	17	34	14,3	5,5	4,3	0,6	1/4-28UNF	1/8	3,7	-20	200	14,0	7,9	0,2	15/16
1	25,4	UC205-16G2T20	52	17	34	14,3	5,5	4,3	0,6	1/4-28UNF	1/8	3,7	-20	200	14,0	7,9	0,2	1
1 1/8	28,575	UC206-18G2T20	62	19	38,1	15,9	5,5	5	0,6	1/4-28UNF	1/8	3,7	-20	200	19,5	11,2	0,3	1 1/8
1 3/16	30,163	UC206-19G2T20	62	19	38,1	15,9	5,5	5	0,6	1/4-28UNF	1/8	3,7	-20	200	19,5	11,2	0,3	1 3/16
1 1/4	31,75	UC206-20G2T20	62	19	38,1	15,9	5,5	5	0,6	1/4-28UNF	1/8	3,7	-20	200	19,5	11,2	0,3	1 1/4
		UC207-20G2T20	72	20	42,9	17,5	6,5	5,8	1,1	5/16-24UNF	5/32	8	-20	200	25,7	15,2	0,5	
1 5/16	33,338	UC207-21G2T20	72	20	42,9	17,5	6,5	5,8	1,1	5/16-24UNF	5/32	8	-20	200	25,7	15,2	0,5	1 5/16
1 3/8	34,925	UC207-22G2T20	72	20	42,9	17,5	6,5	5,8	1,1	5/16-24UNF	5/32	8	-20	200	25,7	15,2	0,5	1 3/8
1 7/16	36,513	UC207-23G2T20	72	20	42,9	17,5	6,5	5,8	1,1	5/16-24UNF	5/32	8	-20	200	25,7	15,2	0,5	1 7/16
1 1/2	38,1	UC208-24G2T20	80	21	49,2	19	8	6,3	1,1	5/16-24UNF	5/32	8	-20	200	29,6	18,2	0,7	1 1/2
1 9/16	39,688	UC208-25G2T20	80	21	49,2	19	8	6,3	1,1	5/16-24UNF	5/32	8	-20	200	29,6	18,2	0,7	1 9/16
1 5/8	41,275	UC209-26G2T20	85	22	49,2	19	8	6,8	1,1	5/16-24UNF	5/32	8	-20	200	31,9	20,8	0,8	1 5/8
1 11/16	42,863	UC209-27G2T20	85	22	49,2	19	8	6,8	1,1	5/16-24UNF	5/32	8	-20	200	31,9	20,8	0,7	1 11/16
1 3/4	44,45	UC209-28G2T20	85	22	49,2	19	8	6,8	1,1	5/16-24UNF	5/32	8	-20	200	31,9	20,8	0,7	1 3/4
1 7/8	47,625	UC210-30G2T20	90	23	51,6	19	9	6,5	1,1	3/8-24UNF	3/16	16,8	-20	200	35,1	23,2	0,9	1 7/8
1 15/16	49,213	UC210-31G2T20	90	23	51,6	19	9	6,5	1,1	3/8-24UNF	3/16	16,8	-20	200	35,1	23,2	0,8	1 15/16
2	50,8	UC211-32G2T20	100	25	55,6	22,2	9	7,2	1,1	3/8-24UNF	3/16	16,8	-20	200	43,6	29,2	1,3	2
2 1/8	53,975	UC211-34G2T20	100	25	55,6	22,2	9	7,2	1,1	3/8-24UNF	3/16	16,8	-20	200	43,6	29,2	1,2	2 1/8
2 3/16	55,563	UC211-35G2T20	100	25	55,6	22,2	9	7,2	1,1	3/8-24UNF	3/16	16,8	-20	200	43,6	29,2	1,1	2 3/16
2 1/4	57,15	UC212-36G2T20	110	27	65,1	25,4	10,5	8,2	1,1	3/8-24UNF	3/16	16,8	-20	200	52,5	32,8	1,7	2 1/4
2 3/8	60,325	UC212-38G2T20	110	27	65,1	25,4	10,5	8,2	1,1	3/8-24UNF	3/16	16,8	-20	200	52,5	32,8	1,5	2 3/8
2 7/16	61,913	UC212-39G2T20	110	27	65,1	25,4	10,5	8,2	1,1	3/8-24UNF	3/16	16,8	-20	200	52,5	32,8	1,5	2 7/16
2 1/2	63,5	UC213-40G2T20	120	28	65,1	25,4	12	8	1,5	3/8-24UNF	3/16	16,8	-20	200	57,2	40,0	1,9	2 1/2
2 11/16	68,263	UC214-43G2T20	125	30	74,6	30,2	12	9	2	7/16-20UNF	7/32	27,1	-20	200	62,0	45,0	2,0	2 11/16
2 3/4	69,85	UC214-44G2T20	125	30	74,6	30,2	12	9	2	7/16-20UNF	7/32	27,1	-20	200	62,0	45,0	2,1	2 3/4
2 15/16	74,613	UC215-47G2T20	130	30	77,8	33,3	12	9	2	7/16-20UNF	7/32	27,1	-20	200	66,0	49,5	2,3	2 15/16
3	76,2	UC215-48G2T20	130	30	77,8	33,3	12	9	2	7/16-20UNF	7/32	27,1	-20	200	66,0	49,5	2,1	3
3 3/16	80,963	UC216-51G2T20	140	33	82,6	33,3	14	10,3	2	7/16-20UNF	7/32	27,1	-20	200	72,5	54,2	2,8	3 3/16
3 1/4	82,55	UC217-52G2T20	150	35	85,7	34,1	14	11	2	7/16-20UNF	7/32	27,1	-20	200	83,2	63,8	3,3	3 1/4
3 1/2	88,9	UC218-56G2T20	160	37	96	39,7	14	12	2	1/2-20UNF	1/4	33,9	-20	200	96,0	71,5	4,6	3 1/2

*Width across flats (hexagon socket)

CHROME STEEL BEARING INSERTS WITH SPHERICAL OUTER RING

ADAPTER SLEEVE TYPES INCLUDED SLEEVES

Basic version
UK2..G2H

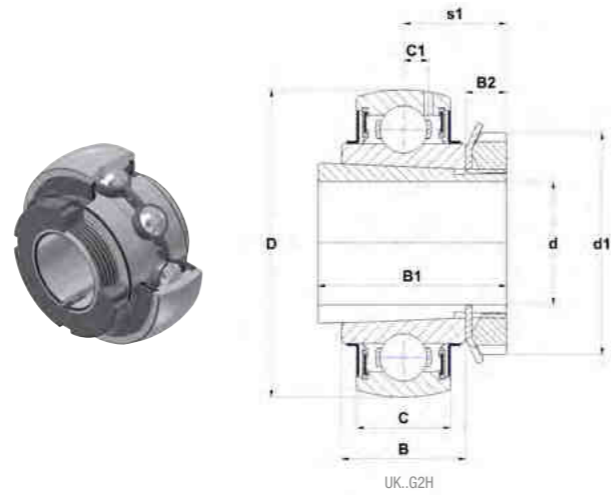

Main dimensions [mm]

d [inch]	d [mm]	Bearing insert	D	C	S1	d1	B	B1	B2	C1	min Temp [°C]	max Temp [°C]	Dynamic load rating C [kN]	Static load rating C0 [kN]	Weight [kg]	d [inch]
3/4	19,05	UK205G2H-12	52	17	18,5	38	21	35	8	4,3	-20	100	14,0	7,9	0,2	3/4
		UK305G2H-12	62	21	21,5	38	27	35	8	6,2	-20	100	22,4	11,5	0,5	
7/8	22,225	UK206G2H-14	62	19	20,5	45	25	38	8	5	-20	100	19,5	11,2	0,4	7/8
		UK306G2H-14	72	24	23	45	30	38	8	6,5	-20	100	27,0	15,2	0,6	
15/16	23,813	UK206G2H-15	62	19	20,5	45	25	38	8	5	-20	100	19,5	11,2	0,4	15/16
		UK306G2H-15	72	24	23	45	30	38	8	6,5	-20	100	27,0	15,2	0,6	
1	25,4	UK206G2H-16	62	19	20,5	45	25	38	8	5	-20	100	19,5	11,2	0,4	1
		UK306G2H-16	72	24	23	45	30	38	8	6,5	-20	100	27,0	15,2	0,6	
1 1/8	28,575	UK207G2H-18	72	20	22,5	52	27	43	9	5,8	-20	100	25,7	15,2	0,6	1 1/8
		UK307G2H-18	80	25	25,5	52	33	43	9	7,2	-20	100	33,5	19,2	0,9	
1 3/16	30,163	UK207G2H-19	72	20	22,5	52	27	43	9	5,8	-20	100	25,7	15,2	0,5	1 3/16
		UK307G2H-19	80	25	25,5	52	33	43	9	7,2	-20	100	33,5	19,2	0,9	
1 1/4	31,75	UK208G2H-20	80	21	24,5	58	29	46	10	6,3	-20	100	29,6	18,2	0,8	1 1/4
		UK308G2H-20	90	28	27,5	58	35	46	10	8,5	-20	100	40,6	24,0	1,1	
1 3/8	34,925	UK208G2H-22	80	21	24,5	58	29	46	10	6,3	-20	100	29,6	18,2	0,7	1 3/8
		UK308G2H-22	90	28	27,5	58	35	46	10	8,5	-20	100	40,6	24,0	1,1	
1 7/16	36,513	UK209G2H-23	85	22	26	65	30	50	11	6,8	-20	100	31,9	20,8	0,8	1 7/16
		UK309G2H-23	100	30	30	65	38	50	11	9	-20	100	53,0	31,8	1,5	
1 1/2	38,1	UK209G2H-24	85	22	26	65	30	50	11	6,8	-20	100	31,9	20,8	0,8	1 1/2
		UK309G2H-24	100	30	30	65	38	50	11	9	-20	100	53,0	31,8	1,5	
1 5/8	41,275	UK210G2H-26	90	23	27,5	70	31	55	12	6,5	-20	100	35,1	23,2	1,0	1 5/8
		UK310G2H-26	110	32	32	70	40	55	12	9,9	-20	100	62,0	37,8	1,7	
1 11/16	42,863	UK210G2H-27	90	23	27,5	70	31	55	12	6,5	-20	100	35,1	23,2	1,0	1 11/16
		UK310G2H-27	110	32	32	70	40	55	12	9,9	-20	100	62,0	37,8	1,8	
1 3/4	44,45	UK210G2H-28	90	23	27,5	70	31	55	12	6,5	-20	100	35,1	23,2	1,0	1 3/4
		UK310G2H-28	110	32	32	70	40	55	12	9,9	-20	100	62,0	37,8	1,7	
1 7/8	47,625	UK211G2H-30	100	25	29	75	33	59	12,5	7,2	-20	100	43,6	29,2	1,2	1 7/8
		UK311G2H-30	120	34	34	75	43	59	12,5	10,6	-20	100	71,5	44,8	2,2	
1 15/16	49,213	UK211G2H-31	100	25	29	75	33	59	12,5	7,2	-20	100	43,6	29,2	1,2	1 15/16
		UK311G2H-31	120	34	34	75	43	59	12,5	10,6	-20	100	71,5	44,8	2,2	
2	50,8	UK211G2H-32	100	25	29	75	33	59	12,5	7,2	-20	100	43,6	29,2	1,1	2
		UK311G2H-32	120	34	34	75	43	59	12,5	10,6	-20	100	71,5	44,8	2,1	
2 3/16	55,563	UK213G2H-35	120	28	32	85	36	65	14	8	-20	100	57,2	40,0	2,1	2 3/16
		UK313G2H-35	140	38	38,5	85	49	65	14	12,1	-20	100	93,9	60,5	3,5	

CHROME STEEL BEARING INSERTS WITH SPHERICAL OUTER RING

ADAPTER SLEEVE TYPES INCLUDED SLEEVES

Basic version
UK2..G2H

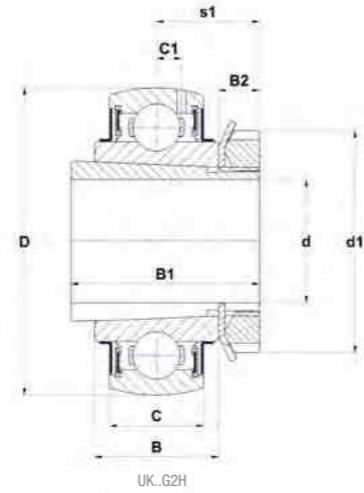

Main dimensions [mm]

d [inch]	d [mm]	Bearing insert	D	C	S1	d1	B	B1	B2	C1	min Temp [°C]	max Temp [°C]	Dynamic load rating C [kN]	Static load rating C0 [kN]	Weight [kg]	d [inch]
2 1/4	57,15	UK213G2H-36	120	28	32	85	36	65	14	8	-20	100	57,2	40,0	2,0	2 1/4
		UK313G2H-36	140	38	38,5	85	49	65	14	12,1	-20	100	93,9	60,5	3,4	
2 7/16	61,913	UK215G2H-39	130	30	35,5	98	41	73	15	9	-20	100	66,0	49,5	2,8	2 7/16
		UK315G2H-39	160	42	42,5	98	55	73	15	13,5	-20	100	113,4	76,8	5,1	
2 1/2	63,5	UK215G2H-40	130	30	35,5	98	41	73	15	9	-20	100	66,0	49,5	2,8	2 1/2
		UK315G2H-40	160	42	42,5	98	55	73	15	13,5	-20	100	113,4	76,8	5,1	
2 11/16	68,263	UK216G2H-43	140	33	39	105	44	78	17	10,3	-20	100	72,5	54,2	3,3	2 11/16
		UK316G2H-43	170	44	44,5	105	55	78	17	14,5	-20	100	122,9	86,5	5,9	
2 3/4	69,85	UK216G2H-44	140	33	39	105	44	78	17	10,3	-20	100	72,5	54,2	3,2	2 3/4
		UK316G2H-44	170	44	44,5	105	55	78	17	14,5	-20	100	122,9	86,5	5,8	
2 15/16	74,613	UK217G2H-47	150	35	40	110	44	82	18	11	-20	100	83,2	63,8	3,8	2 15/16
		UK317G2H-47	180	46	48	110	60	82	18	15,5	-20	100	132,6	96,5	6,8	
3	76,2	UK217G2H-48	150	35	40	110	44	82	18	11	-20	100	83,2	63,8	3,7	3
		UK317G2H-48	180	46	48	110	60	82	18	15,5	-20	100	132,6	96,5	6,7	
3 1/4	82,55	UK319G2H-55	200	50	52	125	66	90	19	16,7	-20	100	156,0	122,0	9,7	3 1/4
3 1/2	88,9	UK320G2H-56	215	54	54	130	68	97	20	19	-20	100	171,6	140,0	10,6	3 1/2

CHROME STEEL BEARING INSERTS WITH CYLINDRICAL OUTER RING

ECCENTRIC LOCKING COLLAR TYPES

Wide design with snap ring groove and lubrication facility **CEX2**

Narrow design with snap ring groove without lubrication facility **CES2**

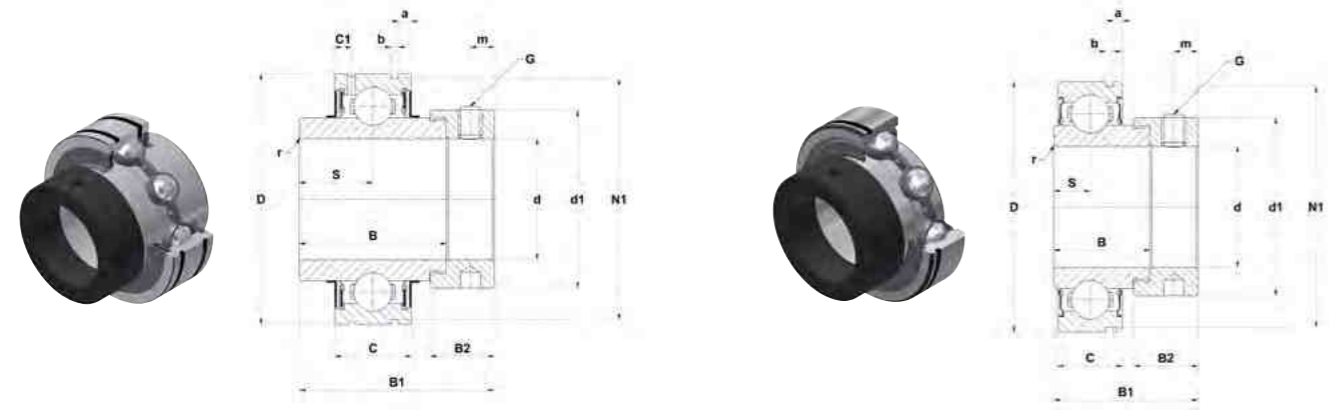

SET SCREW TYPES

Wide design with snap ring groove and lubrication facility **CUC2**

Narrow design with snap ring groove without lubrication facility **CUS2**

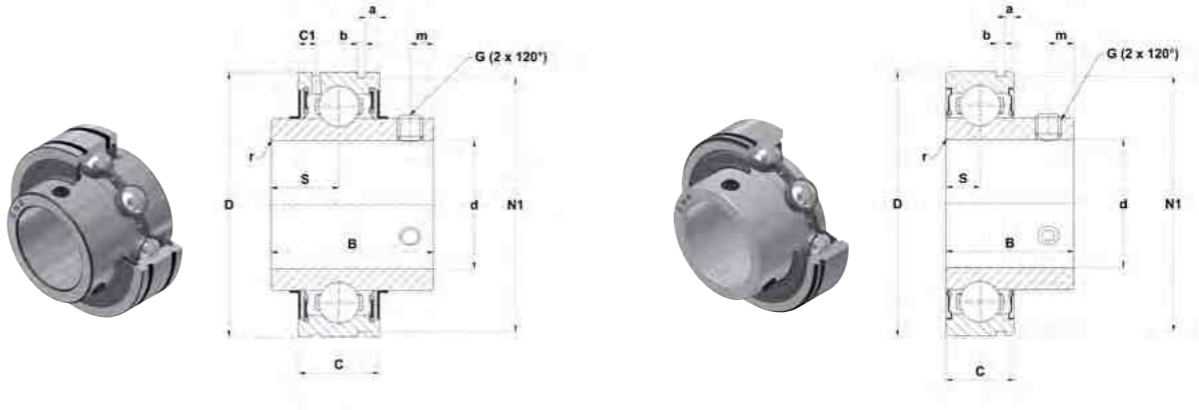

Main dimensions [mm]

d [inch]	d [mm]	Bearing insert	D	C	B	B1	B2	S	d1	C1	a	b	N1	r min	m	G	SW*	Set screw torque [Nm]	min Temp [°C]	max Temp [°C]	Dynamic load rating C [kN]	Static load rating CO [kN]	Weight [kg]	d [inch]
3/4	19,05	CES204-12	47	14	21,5	31	13,5	7	33,3	-	4	1,35	44,6	1	5	1/4-28UNF	3,175	3,7	-20	100	12,8	6,7	0,2	3/4
		CEX204-12	47	17	34,2	43,7	13,5	17,1	33,3	4	3,1	1,35	44,6	1	5	1/4-28UNF	3,175	3,7	-20	100	12,8	6,7	0,2	3/4
		CUC204-12	47	17	31	-	-	12,7	-	4	3,1	1,35	44,6	0,6	4,5	1/4-28UNF	3,175	3,7	-20	100	12,8	6,7	0,2	3/4
		CUS204-12	47	14	25	-	-	7	-	-	2,38	1,35	44,6	1	5	1/4-28UNF	3,175	3,7	-20	100	12,8	6,7	0,1	3/4
7/8	22,225	CES205-14	52	15	21,5	31	13,5	7,5	38,1	-	2,38	1,35	49,73	1	5	1/4-28UNF	3,175	3,7	-20	100	14,0	7,9	0,2	7/8
		CEX205-14	52	17	34,9	44,4	13,5	17,5	38,1	4,1	3,2	1,35	49,73	1	5	1/4-28UNF	3,175	3,7	-20	100	14,0	7,9	0,3	7/8
		CUC205-14	52	17	34	-	-	14,3	-	4,1	3,2	1,35	49,73	0,6	5	1/4-28UNF	3,175	3,7	-20	100	14,0	7,9	0,2	7/8
		CUS205-14	52	15	27	-	-	7,5	-	-	2,38	1,35	49,73	1	5	1/4-28UNF	3,175	3,7	-20	100	14,0	7,9	0,2	7/8
15/16	23,813	CES205-15	52	15	21,5	31	13,5	7,5	38,1	-	2,38	1,35	49,73	1	5	1/4-28UNF	3,175	3,7	-20	100	14,0	7,9	0,2	15/16
		CEX205-15	52	17	34,9	44,4	13,5	17,5	38,1	4,1	3,2	1,35	49,73	1	5	1/4-28UNF	3,175	3,7	-20	100	14,0	7,9	0,3	15/16
		CUC205-15	52	17	34	-	-	14,3	-	4,1	3,2	1,35	49,73	0,6	5	1/4-28UNF	3,175	3,7	-20	100	14,0	7,9	0,2	15/16
		CUS205-15	52	15	27	-	-	7,5	-	-	2,38	1,35	49,73	1	5	1/4-28UNF	3,175	3,7	-20	100	14,0	7,9	0,2	15/16
1	25,4	CES205-16	52	15	21,5	31	13,5	7,5	38,1	-	2,38	1,35	49,73	1	5	1/4-28UNF	3,175	3,7	-20	100	14,0	7,9	0,2	1
		CEX205-16	52	17	34,9	44,4	13,5	17,5	38,1	4,1	3,2	1,35	49,73	1	5	1/4-28UNF	3,175	3,7	-20	100	14,0	7,9	0,2	1
		CUC205-16	52	17	34	-	-	14,3	-	4,1	3,2	1,35	49,73	0,6	5	1/4-28UNF	3,175	3,7	-20	100	14,0	7,9	0,2	1
		CUS205-16	52	15	27	-	-	7,5	-	-	2,38	1,35	49,73	1	5	1/4-28UNF	3,175	3,7	-20	100	14,0	7,9	0,2	1
1 1/8	28,575	CES206-18	62	16	23,8	35,7	15,9	8	44,5	-	3,18	1,9	59,61	1	6	5/16-24UNF	3,969	8	-20	100	19,5	11,2	0,4	1 1/8
		CEX206-18	62	19	36,5	48,4	15,9	18,3	44,5	4,2	3,2	1,9	59,61	1,5	6	5/16-24UNF	3,969	8	-20	100	19,5	11,2	0,4	1 1/8
		CUC206-18	62	19	38,1	-	-	15,9	-	4,2	3,2	1,9	59,61	0,6	5,5	1/4-28UNF	3,175	3,7	-20	100	19,5	11,2	0,3	1 1/8
		CUS206-18	62	16	30	-	-	8	-	-	3,18	1,9	59,61	1	5,5	1/4-28UNF	3,175	3,7	-20	100	19,5	11,2	0,3	1 1/8
1 3/16	30,163	CES206-19	62	16	23,8	35,7	15,9	8	44,5	-	3,18	1,9	59,61	1	6	5/16-24UNF	3,969	8	-20	100	19,5	11,2	0,3	1 3/16
		CEX206-19	62	19	36,5	48,4	15,9	18,3	44,5	4,2	3,2	1,9	59,61	1,5	6	5/16-24UNF	3,969	8	-20	100	19,5	11,2	0,4	1 3/16
		CUC206-19	62	19	38,1	-	-	15,9	-	4,2	3,2	1,9	59,61	0,6	5,5	1/4-28UNF	3,175	3,7	-20	100	19,5	11,2	0,3	1 3/16
		CUS206-19	62	16	30	-	-	8	-	-	3,18	1,9	59,61	1	5,5	1/4-28UNF	3,175	3,7	-20	100	19,5	11,2	0,3	1 3/16
1 1/4	31,75	CES206-20	62	16	23,8	35,7	15,9	8	44,5	-	3,18	1,9	59,61	1	6	5/16-24UNF	3,969	8	-20	100	19,5	11,2	0,3	1 1/4
		CEX206-20	62	19	36,5	48,4	15,9	18,3	44,5	4,2	3,2	1,9	59,61	1,5	6	5/16-24UNF	3,969	8	-20	100	19,5	11,2	0,4	1 1/4
		CUC206-20	62	19	38,1	-	-	15,9	-	4,2	3,2	1,9	59,61	0,6	5,5	1/4-28UNF	3,175	3,7	-20	100	19,5	11,2	0,3	1 1/4
		CUS206-20	62	16	30	-	-	8	-	-	3,18	1,9	59,61	1	5,5	1/4-28UNF	3,175	3,7	-20	100	19,5	11,2	0,2	1 1/4
1 3/8	34,925	CES207-22	72	17	25,4	38,9	17,5	8,5	55,6	-	3,18	1,9	68,81	1,5	6,5	5/16-24UNF	3,969	8	-20	100	25,7	15,2	0,5	1 3/8
		CEX207-22	72	20	37,6	51,1	17,5	18,8	55,5	5	3,3	1,9	68,81	1,5	6,5	5/16-24UNF	3,969	8	-20	100	25,7	15,2	0,6	1 3/8
		CUC207-22	72	20	42,9	-	-	17,5	-	5	3,3	1,9	68,81	1,1	6,5	5/16-24UNF	3,969	8	-20	100	25,7	15,2	0,5	1 3/8
		CUS207-22	72	17	32	-	-	8,5	-	-	3,18	1,9	68,81	1	6	1/4-28UNF	3,175	3,7	-20	100	25,7	15,2	0,4	1 3/8

*Width across flats (hexagon socket)

CHROME STEEL BEARING INSERTS WITH CYLINDRICAL OUTER RING

ECCENTRIC LOCKING COLLAR TYPES

Wide design with snap ring groove and lubrication facility **CEX2**

Narrow design with snap ring groove without lubrication facility **CES2**

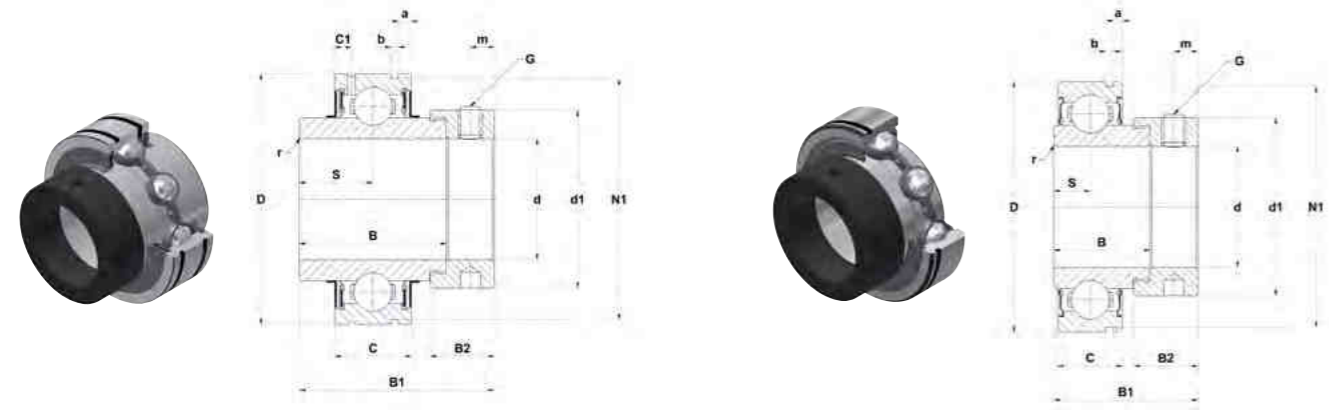

SET SCREW TYPES

Wide design with snap ring groove and lubrication facility **CUC2**

Narrow design with snap ring groove without lubrication facility **CUS2**

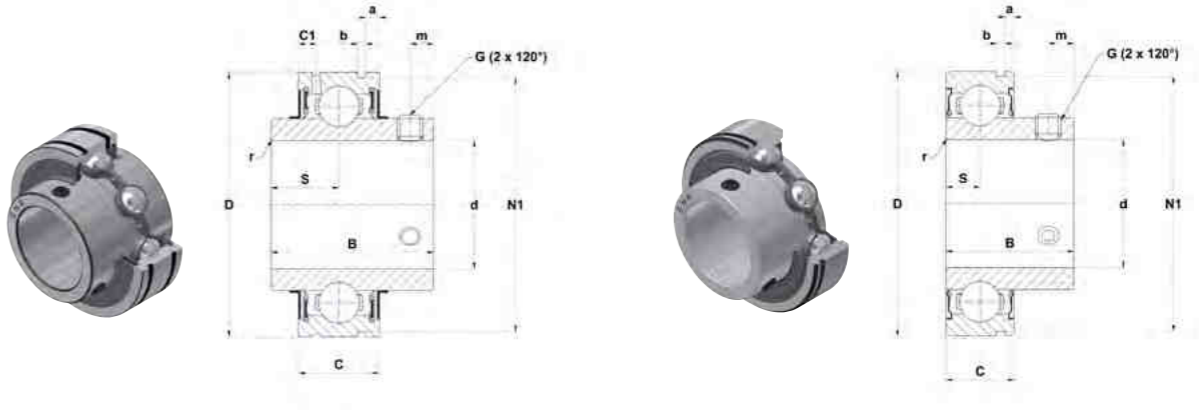

Main dimensions [mm]

d [inch]	d [mm]	Bearing insert	D	C	B	B1	B2	S	d1	C1	a	b	N1	r min	m	G	SW*	Set screw torque [Nm]	min Temp [°C]	max Temp [°C]	Dynamic load rating C [kN]	Static load rating CO [kN]	Weight [kg]	d [inch]
1 7/16	36,513	CES207-23	72	17	25,4	38,9	17,5	8,5	55,6	-	3,18	1,9	68,81	1,5	6,5	5/16-24UNF	3,969	8	-20	100	25,7	15,2	0,5	1 7/16
		CEX207-23	72	20	37,6	51,1	17,5	18,8	55,5	5	3,3	1,9	68,81	1,5	6,5	5/16-24UNF	3,969	8	-20	100	25,7	15,2	0,6	
		CUC207-23	72	20	42,9	-	-	17,5	-	5	3,3	1,9	68,81	1,1	6,5	5/16-24UNF	3,969	8	-20	100	25,7	15,2	0,5	
		CUS207-23	72	17	32	-	-	8,5	-	-	3,18	1,9	68,81	1	6	1/4-28UNF	3,175	3,7	-20	100	25,7	15,2	0,4	
1 1/2	38,1	CES208-24	80	18	30,2	43,7	18,3	9	60,3	-	3,18	1,9	76,81	1,5	6,5	5/16-24UNF	3,969	8	-20	100	32,6	19,9	0,7	1 1/2
		CEX208-24	80	21	42,8	56,3	18,3	21,4	60,3	5	3,4	1,9	76,81	1,5	6,5	5/16-24UNF	3,969	8	-20	100	32,6	19,9	0,8	
		CUC208-24	80	21	49,2	-	-	19	-	5	3,4	1,9	76,81	1,1	8	5/16-24UNF	3,969	8	-20	100	32,6	19,9	0,7	
		CUS208-24	80	18	34	-	-	9	-	-	3,18	1,9	76,81	1	8	5/16-24UNF	3,969	8	-20	100	32,6	19,9	0,6	
1 5/8	41,275	CES209-26	85	19	30,2	43,7	18,3	9,5	63,5	-	3,18	1,9	81,81	1,5	6,5	5/16-24UNF	3,969	8	-20	100	31,9	20,8	0,8	1 5/8
		CEX209-26	85	22	42,8	56,3	18,3	21,4	63,5	5,1	3,5	1,9	81,81	1,5	6,5	5/16-24UNF	3,969	8	-20	100	31,9	20,8	1,0	
		CUC209-26	85	22	49,2	-	-	19	-	5,1	3,5	1,9	81,81	1,1	8	5/16-24UNF	3,969	8	-20	100	31,9	20,8	0,8	
		CUS209-26	85	19	41,2	-	-	9,5	-	-	3,18	1,9	81,81	1,5	8	5/16-24UNF	3,969	8	-20	100	31,9	20,8	0,8	
1 11/16	42,863	CES209-27	85	19	30,2	43,7	18,3	9,5	63,5	-	3,18	1,9	81,81	1,5	6,5	5/16-24UNF	3,969	8	-20	100	31,9	20,8	0,8	1 11/16
		CEX209-27	85	22	42,8	56,3	18,3	21,4	63,5	5,1	3,5	1,9	81,81	1,5	6,5	5/16-24UNF	3,969	8	-20	100	31,9	20,8	0,9	
		CUC209-27	85	22	49,2	-	-	19	-	5,1	3,5	1,9	81,81	1,1	8	5/16-24UNF	3,969	8	-20	100	31,9	20,8	0,7	
		CUS209-27	85	19	41,2	-	-	9,5	-	-	3,18	1,9	81,81	1,5	8	5/16-24UNF	3,969	8	-20	100	31,9	20,8	0,7	
1 3/4	44,45	CES209-28	85	19	30,2	43,7	18,3	9,5	63,5	-	3,18	1,9	81,81	1,5	6,5	5/16-24UNF	3,969	8	-20	100	31,9	20,8	0,7	1 3/4
		CEX209-28	85	22	42,8	56,3	18,3	21,4	63,5	5,1	3,5	1,9	81,81	1,5	6,5	5/16-24UNF	3,969	8	-20	100	31,9	20,8	0,9	
		CUC209-28	85	22	49,2	-	-	19	-	5,1	3,5	1,9	81,81	1,1	8	5/16-24UNF	3,969	8	-20	100	31,9	20,8	0,7	
		CUS209-28	85	19	41,2	-	-	9,5	-	-	3,18	1,9	81,81	1,5	8	5/16-24UNF	3,969	8	-20	100	31,9	20,8	0,7	
1 7/8	47,625	CES210-30	90	20	30,2	43,7	18,3	10	69,9	-	3,7	2,7	86,79	1,5	6,5	5/16-24UNF	3,969	8	-20	100	35,1	23,2	0,9	1 7/8
		CEX210-30	90	24	49,2	62,7	18,3	24,6	69,5	5,6	3,7	2,7	86,79	1,5	6,5	5/16-24UNF	3,969	8	-20	100	35,1	23,2	1,1	
		CUC210-30	90	24	51,6	-	-	19	-	5,6	3,7	2,7	86,79	1,1	9	3/8-24UNF	4,763	16,8	-20	100	35,1	23,2	0,8	
		CUS210-30	90	20	43,5	-	-	10	-	-	3,7	2,7	86,79	1,5	9	5/16-24UNF	3,969	8	-20	100	35,1	23,2	0,8	
1 15/16	49,213	CES210-31	90	20	30,2	43,7	18,3	10	69,9	-	3,7	2,7	86,79	1,5	6,5	5/16-24UNF	3,969	8	-20	100	35,1	23,2	0,8	1 15/16
		CEX210-31	90	24	49,2	62,7	18,3	24,6	69,5	5,6	3,7	2,7	86,79	1,5	6,5	5/16-24UNF	3,969	8	-20	100	35,1	23,2	1,0	
		CUC210-31	90	24	51,6	-	-	19	-	5,6	3,7	2,7	86,79	1,1	9	3/8-24UNF	4,763	16,8	-20	100	35,1	23,2	0,8	
		CUS210-31	90	20	43,5	-	-	10	-	-	3,7	2,7	86,79	1,5	9	5/16-24UNF	3,969	8	-20	100	35,1	23,2	0,8	

*Width across flats (hexagon socket)

STAINLESS STEEL HOUSINGS WITH STAINLESS STEEL BEARING INSERTS

PILLOW BLOCK UNITS

Pillow block
SP2

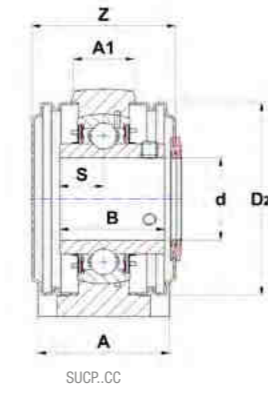
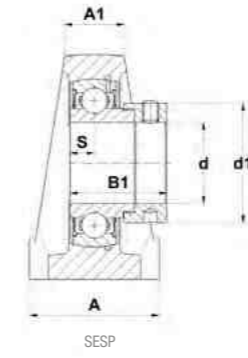
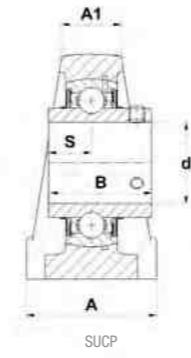
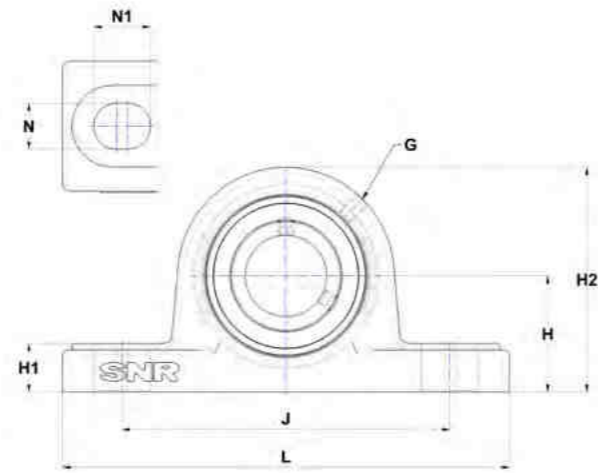

Main dimensions [mm]

d	Unit	L	J	H	H1	H2	A	A1	N	N1	S	B	B1	d1	G	Z	Dz	Housing	Bearing insert	Open protective cap*	Closed protective cap*	Dynamic load rating C [kN]	Static load rating C0 [kN]	Weight [kg]	d
12	SUCP201	126	95	33,3	15	65	38	21	13	19	12,7	31	-	-	M6x1	44,6	54	SP204	SUC201	SC0204-12	SCC204	10,1	6,8	0,9	12
15	SUCP202	126	95	33,3	15	65	38	21	13	19	12,7	31	-	-	M6x1	44,6	54	SP204	SUC202	SC0204-15	SCC204	10,1	6,8	0,9	15
17	SUCP203	126	95	33,3	15	65	38	21	13	19	12,7	31	-	-	M6x1	44,6	54	SP204	SUC203	SC0204-17	SCC204	10,1	6,8	0,9	17
20	SESP204	126	95	33,3	15	65	38	21	13	19	7	21,5	31	33,3	M6x1	63	54	SP204	SES204	SCOE204-20	SCCE204	10,1	6,8	0,9	20
	SUCP204	126	95	33,3	15	65	38	21	13	19	12,7	31	-	-	M6x1	44,6	54	SP204	SUC204	SC0204-20	SCC204	10,1	6,8	0,9	
25	SESP205	140	105	36,5	16	70	38	23,5	13	19	7,5	21,5	31	38,1	M6x1	64	60	SP205	SES205	SCOE205-25	SCCE205	11,0	8,0	1,0	25
	SUCP205	140	105	36,5	16	70	38	23,5	13	19	14,3	34,1	-	-	M6x1	46,8	60	SP205	SUC205	SC0205-25	SCC205	11,0	8,0	1,0	
30	SESP206	165	121	42,9	18	83	48	24	17	21	8	23,8	35,7	44,5	M6x1	70	70	SP206	SES206	SCOE206-30	SCCE206	15,3	11,5	1,6	30
	SUCP206	165	121	42,9	18	83	48	24	17	21	15,9	38,1	-	-	M6x1	51,8	70	SP206	SUC206	SC0206-30	SCC206	15,3	11,5	1,6	
35	SESP207	167	127	47,6	19	94	48	27	17	21	8,5	25,4	38,9	55,6	M6x1	76	80	SP207	SES207	SCOE207-35	SCCE207	20,1	15,6	2,0	35
	SUCP207	167	127	47,6	19	94	48	27	17	21	17,5	42,9	-	-	M6x1	57,4	80	SP207	SUC207	SC0207-35	SCC207	20,1	15,6	2,0	
40	SESP208	184	136	49,2	19	100	54	27	17	23	9	30,2	43,7	60,3	M6x1	80	88	SP208	SES208	SCOE208-40	SCCE208	22,8	18,2	2,3	40
	SUCP208	184	136	49,2	19	100	54	27	17	23	19	49,2	-	-	M6x1	67,8	88	SP208	SUC208	SC0208-40	SCC208	32,0	19,3	2,3	
45	SESP209	190	146	54	20	109	54	28	17	23	9,5	30,2	43,7	63,5	M6x1	82,5	95	SP209	SES209	SCOE209-45	SCCE209	25,7	20,8	2,7	45
	SUCP209	190	146	54	20	109	54	28	17	23	19	49,2	-	-	M6x1	68,3	95	SP209	SUC209	SC0209-45	SCC209	25,7	20,8	2,7	
50	SESP210	206	159	57,2	22	114	60	30	20	25	10	30,2	43,7	69,9	M6x1	90	100	SP210	SES210	SCOE210-50	SCCE210	27,5	23,7	3,3	50
	SUCP210	206	159	57,2	22	114	60	30	20	25	19	51,6	-	-	M6x1	74,6	100	SP210	SUC210	SC0210-50	SCC210	27,5	23,7	3,3	
55	SESP211	219	171	63,5	23	126	60	33	20	25	10,5	32,5	48,4	76,2	M6x1	103	110	SP211	SES211	SCOE211-55	SCCE211	34,0	25,5	4,1	55
	SUCP211	219	171	63,5	23	126	60	33	20	25	22,2	55,6	-	-	M6x1	76,2	110	SP211	SUC211	SC0211-55	SCC211	34,0	25,5	4,2	
60	SESP212	241	184	69,8	25	138	70	37	20	25	11	37,1	53,1	84,2	M6x1	111	120	SP212	SES212	SCOE212-60	SCCE212	41,0	31,5	5,5	60
	SUCP212	241	184	69,8	25	138	70	37	20	25	25,4	65,1	-	-	M6x1	89,8	120	SP212	SUC212	SC0212-60	SCC212	41,0	31,5	5,7	

* Bearing units that are ordered with cover(s) include the housings with grooves.
If you want to install the protective covers later, housings with suffix N must be ordered (for example: P210N).

STAINLESS STEEL HOUSINGS WITH STAINLESS STEEL BEARING INSERTS

PILLOW BLOCK UNITS

Tapped base pillow block
SPA2

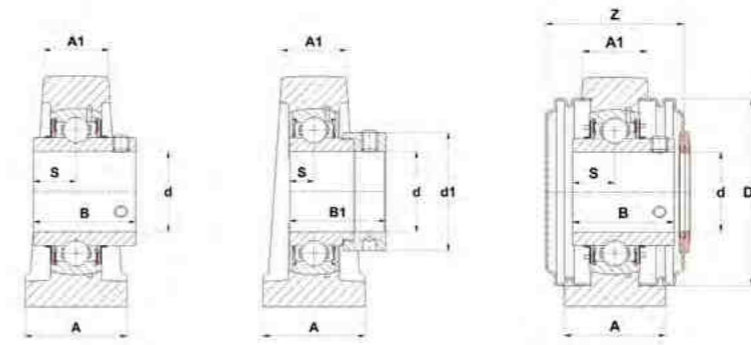
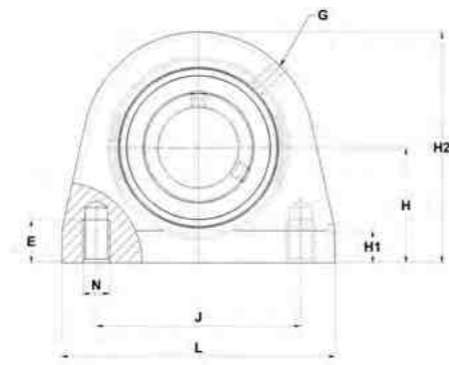

Main dimensions [mm]

d	Unit	L	J	H	H1	H2	A	A1	N	S	B	B1	d1	G	Z	Dz	Housing	Bearing insert	Open protective cap*	Closed protective cap*	Dynamic load rating C [kN]	Static load rating C0 [kN]	Weight [kg]	d
12	SUCPA201	73	50,8	33,3	11	65	38	23	M8	12,7	31	-	-	M6x1	45,6	54	SPA204	SUC201	SC0204-12	SCC204	10,1	6,8	0,7	12
15	SUCPA202	73	50,8	33,3	11	65	38	23	M8	12,7	31	-	-	M6x1	45,6	54	SPA204	SUC202	SC0204-15	SCC204	10,1	6,8	0,7	15
17	SUCPA203	73	50,8	33,3	11	65	38	23	M8	12,7	31	-	-	M6x1	45,6	54	SPA204	SUC203	SC0204-17	SCC204	10,1	6,8	0,7	17
20	SESPA204	73	50,8	33,3	11	65	38	23	M8	7	21,5	31	33,3	M6x1	64	54	SPA204	SES204	SC0E204-20	SCCE204	10,1	6,8	0,7	20
	SUCPA204	73	50,8	33,3	11	65	38	23	M8	12,7	31	-	-	M6x1	45,6	54	SPA204	SUC204	SC0204-20	SCC204	10,1	6,8	0,7	20
25	SESPA205	76	50,8	36,5	12	71	38	24	M10	7,5	21,5	31	38,1	M6x1	63,5	60	SPA205	SES205	SC0E205-25	SCCE205	11,0	8,0	0,8	25
	SUCPA205	76	50,8	36,5	12	71	38	24	M10	14,3	34,1	-	-	M6x1	46,3	60	SPA205	SUC205	SC0205-25	SCC205	11,0	8,0	0,8	25
30	SESPA206	102	76,2	42,9	12	86	38	24	M10	8	23,8	35,7	44,5	M6x1	70	70	SPA206	SES206	SC0E206-30	SCCE206	15,3	11,5	1,3	30
	SUCPA206	102	76,2	42,9	12	86	38	24	M10	15,9	38,1	-	-	M6x1	51,8	70	SPA206	SUC206	SC0206-30	SCC206	15,3	11,5	1,3	30
35	SESPA207	108	82,6	47,6	12	95	48	25	M10	8,5	25,4	38,9	55,6	M6x1	76	80	SPA207	SES207	SC0E207-35	SCCE207	20,1	15,6	1,7	35
	SUCPA207	108	82,6	47,6	12	95	48	25	M10	17,5	42,9	-	-	M6x1	57,4	80	SPA207	SUC207	SC0207-35	SCC207	20,1	15,6	1,7	35
40	SESPA208	117	89	49,2	13	100	48	28	M12	9	30,2	43,7	60,3	M6x1	80	88	SPA208	SES208	SC0E208-40	SCCE208	22,8	18,2	1,9	40
	SUCPA208	117	89	49,2	13	100	48	28	M12	19	49,2	-	-	M6x1	67,8	88	SPA208	SUC208	SC0208-40	SCC208	32,0	19,3	1,9	40
45	SESPA209	127	95,3	54	13	108	51	28	M12	9,5	30,2	43,7	63,5	M6x1	82	95	SPA209	SES209	SC0E209-45	SCCE209	25,7	20,8	2,3	45
	SUCPA209	127	95,3	54	13	108	51	28	M12	19	49,2	-	-	M6x1	67,8	95	SPA209	SUC209	SC0209-45	SCC209	25,7	20,8	2,3	45
50	SESPA210	140	101,6	57,2	13	117	51	29	M16	10	30,2	43,7	69,9	M6x1	90	100	SPA210	SES210	SC0E210-50	SCCE210	27,5	23,7	2,8	50
	SUCPA210	140	101,6	57,2	13	117	51	29	M16	19	51,6	-	-	M6x1	74,6	100	SPA210	SUC210	SC0210-50	SCC210	27,5	23,7	2,8	50

* Bearing units that are ordered with cover(s) include the housings with grooves.
If you want to install the protective covers later, housings with suffix N must be ordered (for example: P210N).

STAINLESS STEEL HOUSINGS WITH STAINLESS STEEL BEARING INSERTS

FLANGED UNITS

Four-bolt flange, square design

SF2

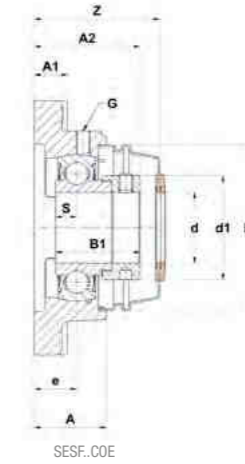
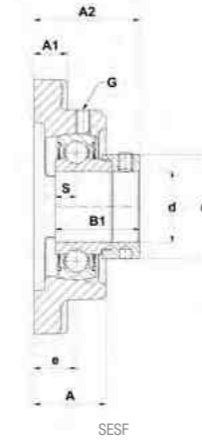
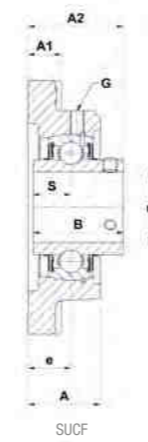
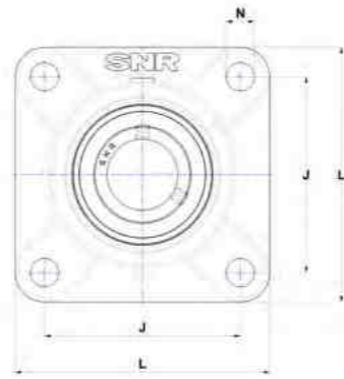

Main dimensions [mm]

d	Unit	L	J	A	A1	A2	N	S	B	B1	d1	G	Z	Dz	Housing	Bearing insert	Open protective cap*	Closed protective cap*	Dynamic load rating C [kN]	Static load rating C0 [kN]	Weight [kg]	d
12	SUCF201	86	64	25,5	12	33,3	12	12,7	31	-	-	M6x1	36,6	54	SF204	SUC201	SC0204-12	SCC204	10,1	6,8	0,8	12
15	SUCF202	86	64	25,5	12	33,3	12	12,7	31	-	-	M6x1	36,6	54	SF204	SUC202	SC0204-15	SCC204	10,1	6,8	0,7	15
17	SUCF203	86	64	25,5	12	33,3	12	12,7	31	-	-	M6x1	36,6	54	SF204	SUC203	SC0204-17	SCC204	10,1	6,8	0,7	17
20	SESF204	86	64	25,5	12	39	12	7	21,5	31	33,3	M6x1	45,8	54	SF204	SES204	SC0E204-20	SCCE204	10,1	6,8	0,7	20
	SUCF204	86	64	25,5	12	33,3	12	12,7	31	-	-	M6x1	36,6	54	SF204	SUC204	SC0204-20	SCC204	10,1	6,8	0,7	
25	SESF205	95	70	27	14	39,5	12	7,5	21,5	31	38,1	M6x1	47,8	60	SF205	SES205	SC0E205-25	SCCE205	11,0	8,0	0,9	25
	SUCF205	95	70	27	14	35,8	12	14,3	34,1	-	-	M6x1	39,2	60	SF205	SUC205	SC0205-25	SCC205	11,0	8,0	0,9	
30	SESF206	108	83	30,5	14	45,7	12	8	23,8	35,7	44,5	M6x1	53,3	70	SF206	SES206	SC0E206-30	SCCE206	15,3	11,5	1,3	30
	SUCF206	108	83	30,5	14	40,2	12	15,9	38,1	-	-	M6x1	44,2	70	SF206	SUC206	SC0206-30	SCC206	15,3	11,5	1,3	
35	SESF207	116	92	33,5	14,5	49,4	14	8,5	25,4	38,9	55,6	M6x1	56,8	80	SF207	SES207	SC0E207-35	SCCE207	20,1	15,6	1,7	35
	SUCF207	116	92	33,5	14,5	44,4	14	17,5	42,9	-	-	M6x1	47,5	80	SF207	SUC207	SC0207-35	SCC207	20,1	15,6	1,6	
40	SESF208	130	102	36	14,5	55,7	16	9	30,2	43,7	60,3	M6x1	60,8	88	SF208	SES208	SC0E208-40	SCCE208	22,8	18,2	2,2	40
	SUCF208	130	102	36	14,5	51,2	16	19	49,2	-	-	M6x1	54,7	88	SF208	SUC208	SC0208-40	SCC208	32,0	19,3	2,2	
45	SESF209	137	105	38	15,5	56,2	16	9,5	30,2	43,7	63,5	M6x1	63,1	95	SF209	SES209	SC0E209-45	SCCE209	25,7	20,8	2,6	45
	SUCF209	137	105	38	15,5	52,2	16	19	49,2	-	-	M6x1	56	95	SF209	SUC209	SC0209-45	SCC209	25,7	20,8	2,6	
50	SESF210	143	111	40	15	55,7	16	10	30,2	43,7	69,9	M6x1	66,8	100	SF210	SES210	SC0E210-50	SCCE210	27,5	23,7	2,8	50
	SUCF210	143	111	40	15	54,6	16	19	51,6	-	-	M6x1	59,1	100	SF210	SUC210	SC0210-50	SCC210	27,5	23,7	2,9	
55	SUCF211	162	130	44	20	58,4	19	22,2	55,6	-	-	M6x1	61,9	110	SF211	SUC211	SC0211-55	SCC211	34,0	25,5	4,2	55
60	SUCF212	175	143	48	20	68,7	19	25,4	65,1	-	-	M6x1	72,1	120	SF212	SUC212	SC0212-60	SCC212	41,0	31,5	5,8	60

* Bearing units that are ordered with cover(s) include the housings with grooves.
If you want to install the protective covers later, housings with suffix N must be ordered (for example: P210N).

STAINLESS STEEL HOUSINGS WITH STAINLESS STEEL BEARING INSERTS

FLANGED UNITS

Two-bolt flange, oval design

SFL2

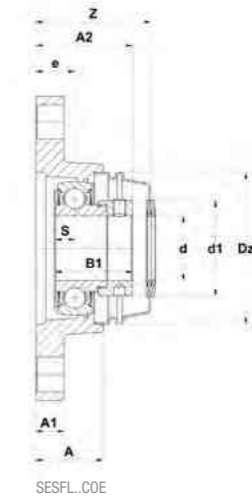
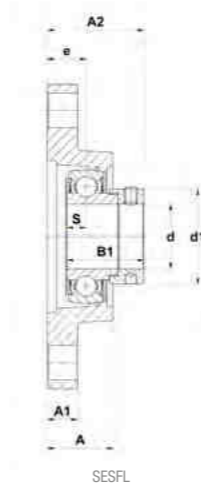
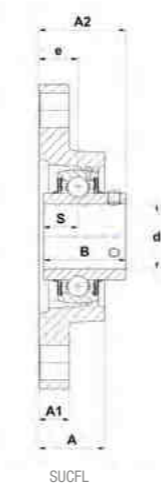
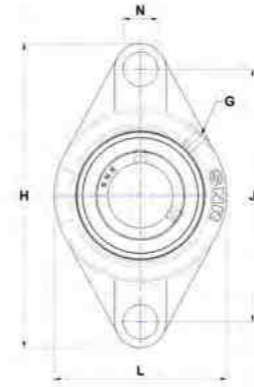

Main dimensions [mm]

d	Unit	H	L	J	A	A1	A2	N	S	B	B1	d1	G	Z	Dz	Housing	Bearing insert	Open protective cap*	Closed protective cap*	Dynamic load rating C [kN]	Static load rating C0 [kN]	Weight [kg]	d
12	SUCFL201	112	58,5	90	25,5	12	33,3	12	12,7	31	-	-	M6x1	36,6	54	SFL204	SUC201	SC0204-12	SCC204	10,1	6,8	0,5	12
15	SUCFL202	112	58,5	90	25,5	12	33,3	12	12,7	31	-	-	M6x1	36,6	54	SFL204	SUC202	SC0204-15	SCC204	10,1	6,8	0,5	15
17	SUCFL203	112	58,5	90	25,5	12	33,3	12	12,7	31	-	-	M6x1	36,6	54	SFL204	SUC203	SC0204-17	SCC204	10,1	6,8	0,5	17
20	SESFL204	112	58,5	90	25,5	12	39	12	7	21,5	31	33,3	M6x1	45,8	54	SFL204	SES204	SC0E204-20	SCCE204	10,1	6,8	0,5	20
	SUCFL204	112	58,5	90	25,5	12	33,3	12	12,7	31	-	-	M6x1	36,6	54	SFL204	SUC204	SC0204-20	SCC204	10,1	6,8	0,5	
25	SESFL205	125	68	99	27	13	39,5	13,5	7,5	21,5	31	38,1	M6x1	47,5	60	SFL205	SES205	SC0E205-25	SCCE205	11,0	8,0	0,6	25
30	SESFL206	141	80	117	31	13	45,7	13,5	8	23,8	35,7	44,5	M6x1	53	70	SFL206	SES206	SC0E206-30	SCCE206	15,3	11,5	0,9	30
	SUCFL206	141	80	117	31	13	40,2	13,5	15,9	38,1	-	-	M6x1	43,9	70	SFL206	SUC206	SC0206-30	SCC206	15,3	11,5	0,9	
35	SESFL207	156	90	130	33	15	49,4	16	8,5	25,4	38,9	55,6	M6x1	57	80	SFL207	SES207	SC0E207-35	SCCE207	20,1	15,6	1,3	35
	SUCFL207	156	90	130	33	15	44,4	16	17,5	42,9	-	-	M6x1	47,7	80	SFL207	SUC207	SC0207-35	SCC207	20,1	15,6	1,2	
40	SESFL208	172	100	144	36	15	55,7	16	9	30,2	43,7	60,3	M6x1	60,5	88	SFL208	SES208	SC0E208-40	SCCE208	22,8	18,2	1,7	40
	SUCFL208	172	100	144	36	15	51,2	16	19	49,2	-	-	M6x1	54,4	88	SFL208	SUC208	SC0208-40	SCC208	32,0	19,3	1,7	
45	SESFL209	180	108	148	38	15	56,2	17,5	9,5	30,2	43,7	63,5	M6x1	63	95	SFL209	SES209	SC0E209-45	SCCE209	25,7	20,8	2,0	45
	SUCFL209	180	108	148	38	15	52,2	17,5	19	49,2	-	-	M6x1	55,9	95	SFL209	SUC209	SC0209-45	SCC209	25,7	20,8	2,0	
50	SESFL210	190	115	157	39	16	55,7	17,5	10	30,2	43,7	69,9	M6x1	67	100	SFL210	SES210	SC0E210-50	SCCE210	27,5	23,7	2,3	50
	SUCFL210	190	115	157	39	16	54,6	17,5	19	51,6	-	-	M6x1	59,3	100	SFL210	SUC210	SC0210-50	SCC210	27,5	23,7	2,4	

* Bearing units that are ordered with cover(s) include the housings with grooves.
If you want to install the protective covers later, housings with suffix N must be ordered (for example: P210N).

STAINLESS STEEL HOUSINGS WITH STAINLESS STEEL BEARING INSERTS

FLANGED UNITS

Three-bolt flange
SFB2

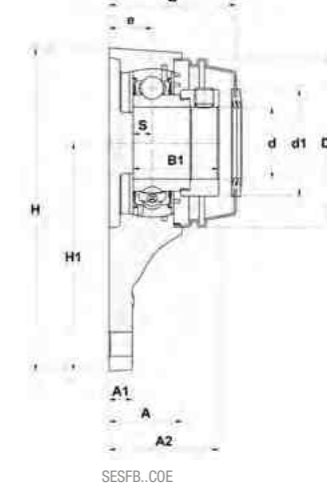
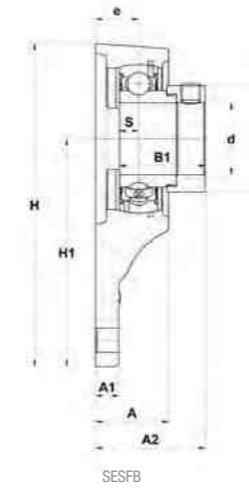
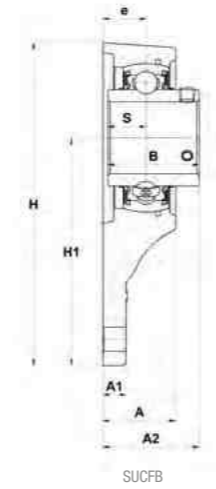
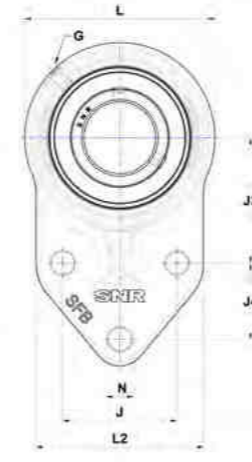

Main dimensions [mm]

d	Unit	H	H1	L	L2	J	J3	J4	A	A1	A2	e	N	S	B	B1	d1	G	Z	Dz	Housing	Bearing insert	Open protective cap*	Closed protective cap*	Dynamic load rating C [kN]	Static load rating C0 [kN]	Weight [kg]	d
12	SUCFB201	106,4	76,2	60,5	60,2	38,1	42,9	22,4	25,5	7,9	33,3	15	10	12,7	31	-	-	M6x1	36,9	54	SFB204	SUC201	SCO204-12	SCC204	10,1	6,8	0,6	12
15	SUCFB202	106,4	76,2	60,5	60,2	38,1	42,9	22,4	25,5	7,9	33,3	15	10	12,7	31	-	-	M6x1	36,9	54	SFB204	SUC202	SCO204-15	SCC204	10,1	6,8	0,5	15
17	SUCFB203	106,4	76,2	60,5	60,2	38,1	42,9	22,4	25,5	7,9	33,3	15	10	12,7	31	-	-	M6x1	36,9	54	SFB204	SUC203	SCO204-17	SCC204	10,1	6,8	0,5	17
20	SESFB204	106,4	76,2	60,5	60,2	38,1	42,9	22,4	25,5	7,9	39	15	10	7	21,5	31	33,3	M6x1	46,1	54	SFB204	SES204	SCO204-20	SCCE204	10,1	6,8	0,5	20
	SUCFB204	106,4	76,2	60,5	60,2	38,1	42,9	22,4	25,5	7,9	33	15	10	12,7	31	-	-	M6x1	36,9	54	SFB204	SUC204	SCO204-20	SCC204	10,1	6,8	0,5	
25	SESFB205	119	85,5	67	63,5	41,4	46	28,7	27	9,7	39,5	16	10	7,5	21,5	31	38,1	M6x1	47,7	60	SFB205	SES205	SCO205-25	SCCE205	11,0	8,0	0,7	25
	SUCFB205	119	85,5	67	63,5	41,4	46	28,7	27	9,7	36	16	10	14,3	34,1	-	-	M6x1	39,1	60	SFB205	SUC205	SCO205-25	SCC205	11,0	8,0	0,6	
30	SESFB206	135	95,3	79,5	70	47,8	52,3	31,8	30,5	9,7	45,7	18	10	8	23,8	35,7	44,5	M6x1	53	70	SFB206	SES206	SCO206-30	SCCE206	15,3	11,5	0,9	30
	SUCFB206	135	95,3	79,5	70	47,8	52,3	31,8	30,5	9,7	40,2	18	10	15,9	38,1	-	-	M6x1	43,9	70	SFB206	SUC206	SCO206-30	SCC206	15,3	11,5	0,9	
	SUCFB206N	135	95,3	79,5	70	47,8	52,3	31,8	30,5	9,7	40,2	18	10	15,9	38,1	-	-	M6x1	-	-	SFB206	SUC206	-	-	15,3	11,5	0,9	
35	SESFB207	152,2	107,2	90	83	50,8	60,5	31,8	33	12,7	49,4	19	13,5	8,5	25,4	38,9	55,6	M6x1	57	80	SFB207	SES207	SCO207-35	SCCE207	20,1	15,6	1,4	35
	SUCFB207	152,2	107,2	90	83	50,8	60,5	31,8	33	12,7	44,4	19	13,5	17,5	42,9	0	-	M6x1	47,7	80	SFB207	SUC207	SCO207-35	SCC207	20,1	15,6	1,4	
40	SESFB208	164	114	100	78	50	60,3	41,3	36	12,7	55,7	21	13,5	9	30,2	43,7	60,3	M6x1	61,5	88	SFB208	SES208	SCO208-40	SCCE208	22,8	18,2	1,7	40
	SUCFB208	164	114	100	78	50	60,3	41,3	36	12,7	51,2	21	13,5	19	49,2	0	-	M6x1	55,4	88	SFB208	SUC208	SCO208-40	SCC208	32,0	19,3	1,7	
50	SESFB210	186,5	131,8	109,5	101,5	69,9	74,7	41,4	39	12,7	55,7	22	13,5	10	30,2	43,7	69,9	M6x1	67,5	100	SFB210	SES210	SCO210-50	SCCE210	27,5	23,7	2,2	50
	SUCFB210	186,5	131,8	109,5	101,5	69,9	74,7	41,4	39	12,7	54,6	22	13,5	19	51,6	-	-	M6x1	59,8	100	SFB210	SUC210	SCO210-50	SCC210	27,5	23,7	2,3	

* Bearing units that are ordered with cover(s) include the housings with grooves.
If you want to install the protective covers later, housings with suffix N must be ordered (for example: P210N).

STAINLESS STEEL HOUSINGS WITH STAINLESS STEEL BEARING INSERTS

TENSIONER UNITS

Take-up
ST2

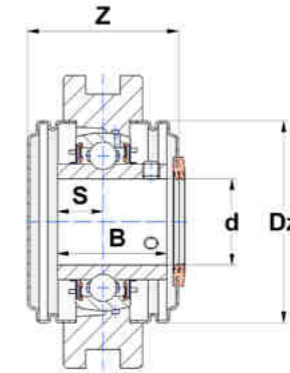
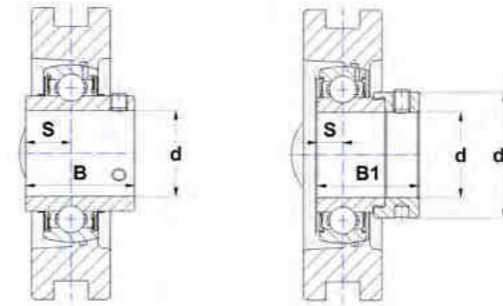
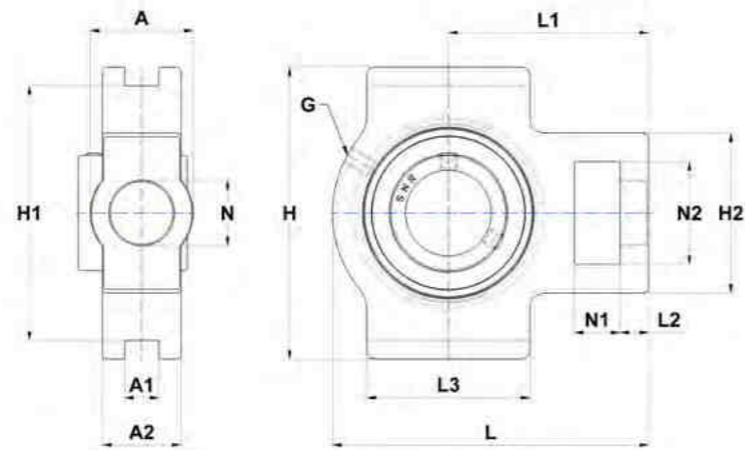

Main dimensions [mm]

d	Unit	L	L1	L2	L3	A	A1	A2	H	H1	H2	N	N1	N2	S	B	B1	d1	G	Z	Dz	Housing	Bearing insert	Open protective cap*	Closed protective cap*	Dynamic load rating C [kN]	Static load rating CO [kN]	Weight [kg]	d
12	SUCT201	94	61	10	51	32	12	21	89	76	51	19	16	32	12,7	31	-	-	M6x1	44,6	54	ST204	SUC201	SCO204-12	SCC204	10,1	6,8	0,9	12
15	SUCT202	94	61	10	51	32	12	21	89	76	51	19	16	32	12,7	31	-	-	M6x1	44,6	54	ST204	SUC202	SCO204-15	SCC204	10,1	6,8	0,8	15
17	SUCT203	94	61	10	51	32	12	21	89	76	51	19	16	32	12,7	31	-	-	M6x1	44,6	54	ST204	SUC203	SCO204-17	SCC204	10,1	6,8	0,8	17
20	SEST204	94	61	10	51	32	12	21	89	76	51	19	16	32	7	21,5	31	33,3	M6x1	44,6	54	ST204	SES204	SCO204-20	SCCE204	10,1	6,8	0,8	20
	SUCT204	94	61	10	51	32	12	21	89	76	51	19	16	32	12,7	31	-	-	M6x1	44,6	54	ST204	SUC204	SCO204-20	SCC204	10,1	6,8	0,8	
25	SEST205	95	60,5	8	51	32	12	24	89	76	51	19	16	32	7,5	21,5	31	38,1	M6x1	64,6	60	ST205	SES205	SCO205-25	SCCE205	11,0	8,0	0,9	25
	SUCT205	95	60,5	8	51	32	12	24	89	76	51	19	16	32	14,3	34,1	-	-	M6x1	47,4	60	ST205	SUC205	SCO205-25	SCC205	11,0	8,0	1,0	
30	SEST206	113	70	10	57	37	12	28	102	89	56	22	16	37	8	23,8	35,7	44,5	M6x1	70,6	70	ST206	SES206	SCO206-30	SCCE206	15,3	11,5	1,3	30
	SUCT206	113	70	10	57	37	12	28	102	89	56	22	16	37	15,9	38,1	-	-	M6x1	52,4	70	ST206	SUC206	SCO206-30	SCC206	15,3	11,5	1,3	
35	SEST207	129	78	13	64	37	12	30	102	89	64	22	16	37	8,5	25,4	38,9	55,6	M6x1	76	80	ST207	SES207	SCO207-35	SCCE207	20,1	15,6	1,8	35
	SUCT207	129	78	13	64	37	12	30	102	89	64	22	16	37	17,5	42,9	0	-	M6x1	57,4	80	ST207	SUC207	SCO207-35	SCC207	20,1	15,6	1,7	
40	SEST208	144	88	16	83	49	16	33	114	102	83	29	19	49	9	30,2	43,7	60,3	M6x1	79	88	ST208	SES208	SCO208-40	SCCE208	22,8	18,2	2,5	40
	SUCT208	144	88	16	83	49	16	33	114	102	83	29	19	49	19	49,2	0	-	M6x1	66,8	88	ST208	SUC208	SCO208-40	SCC208	32,0	19,3	2,5	
45	SEST209	144	87	16	83	49	16	35	117	102	83	29	19	49	9,5	30,2	43,7	63,5	M6x1	82,8	95	ST209	SES209	SCO209-45	SCCE209	25,7	20,8	2,5	45
	SUCT209	144	87	16	83	49	16	35	117	102	83	29	19	49	19	49,2	-	-	M6x1	68,6	95	ST209	SUC209	SCO209-45	SCC209	25,7	20,8	2,5	
50	SEST210	149	90	16	86	49	16	37	117	102	83	29	19	49	10	30,2	43,7	69,9	M6x1	90,6	100	ST210	SES210	SCO210-50	SCCE210	27,5	23,7	2,7	50
	SUCT210	149	90	16	86	49	16	37	117	102	83	29	19	49	19	51,6	-	-	M6x1	75,2	100	ST210	SUC210	SCO210-50	SCC210	27,5	23,7	2,7	

* Bearing units that are ordered with cover(s) include the housings with grooves.
If you want to install the protective covers later, housings with suffix N must be ordered (for example: P210N).

THERMOPLASTIC HOUSINGS WITH STAINLESS STEEL BEARING INSERTS

PILLOW BLOCK UNITS

Pillow block
PPL2

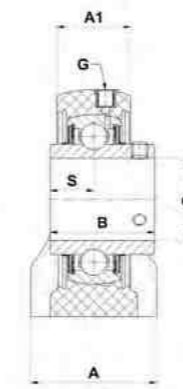
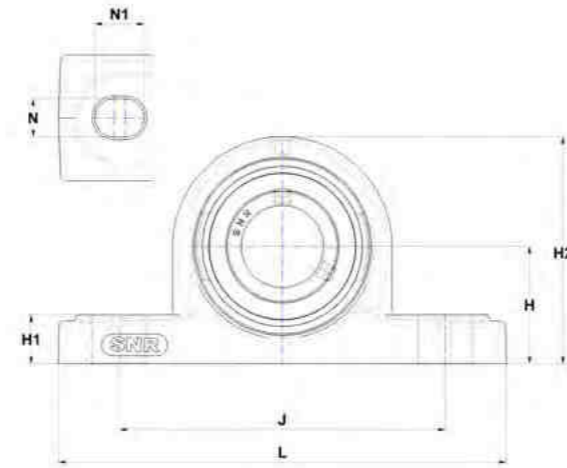

MUCPPL

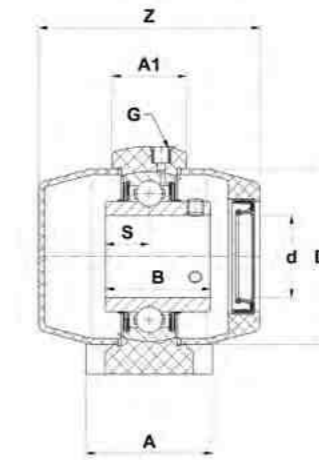

MUCPPL + protective caps

Main dimensions [mm]

d	Unit	L	J	H	H1	H2	A	A1	N	N1	S	B	G	Z	Dz	Housing	Bearing insert	Open protective cap	Closed protective cap	Dynamic load rating C [kN]	Static load rating C0 [kN]	Weight [kg]	d
20	MUCPPL204	127	95	33,3	14,2	65	38	22,5	11	14	12,7	31	1/4-28 UNF	63,3	50	PPL204	MUC204FD	CV204	CF204	10,9	5,3	0,3	20
25	MUCPPL205	140	105	36,5	14,5	71	38	24,5	11	14	14,3	34,1	1/4-28 UNF	68,1	55	PPL205	MUC205FD	CV205	CF205	11,9	6,3	0,3	25
30	MUCPPL206	162	119	42,9	17,8	83	46	27	14	18	15,9	38,1	1/4-28 UNF	80,4	64	PPL206	MUC206FD	CV206	CF206	16,7	9,0	0,5	30
35	MUCPPL207	167	127	47,6	18	94	48	32,5	14	18	17,5	42,9	1/4-28 UNF	89,7	74,5	PPL207	MUC207FD	CV207	CF207	22,0	12,3	0,8	35
40	MUCPPL208	184	137	49,2	19,5	98	54	36	14	18	19	49,2	1/4-28 UNF	103	84	PPL208	MUC208FD	CV208	CF208	24,9	14,3	1,0	40

Tapped base pillow block
TBL2

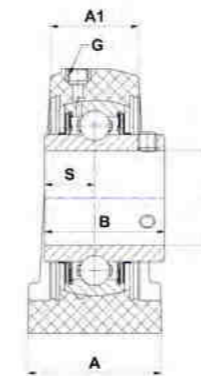
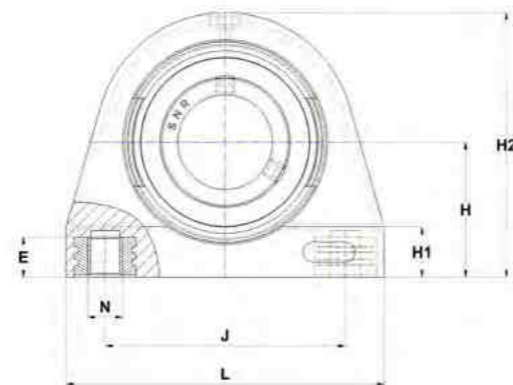

MUCTBL

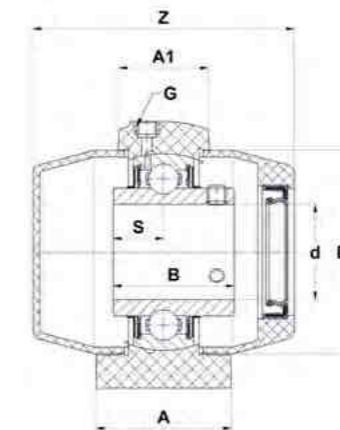

MUCTBL + protective caps

Main dimensions [mm]

d	Unit	L	J	H	H1	H2	A	A1	N	E	S	B	G	Z	Dz	Housing	Bearing insert	Open protective cap	Closed protective cap	Dynamic load rating C [kN]	Static load rating C0 [kN]	Weight [kg]	d
20	MUCTBL204	72,8	50,8	33,3	13	66	34,5	23,8	M8	12	12,7	31	1/4-28 UNF	64,7	50	TBL204	MUC204FD	CV204	CF204	10,9	5,3	0,3	20
25	MUCTBL205	76,2	50,8	36,5	14	73,5	39,5	25,44	M10	12	14,3	34,1	1/4-28 UNF	70	55	TBL205	MUC205FD	CV205	CF205	11,9	6,3	0,3	25
30	MUCTBL206	101	76,2	42,9	16	84	42,5	28	M10	12	15,9	38,1	1/4-28 UNF	82,3	64	TBL206	MUC206FD	CV206	CF206	16,7	9,0	0,5	30
35	MUCTBL207	110	82,6	47,6	18,5	95	47,5	32,5	M10	15,5	17,5	42,9	1/4-28 UNF	89,9	74,5	TBL207	MUC207FD	CV207	CF207	22,0	12,3	0,7	35
40	MUCTBL208	120	88,9	49,2	22,5	100,5	48	35	M12	16	19	49,2	1/4-28 UNF	102,8	84	TBL208	MUC208FD	CV208	CF208	24,9	14,3	0,9	40

THERMOPLASTIC HOUSINGS WITH STAINLESS STEEL BEARING INSERTS

FLANGED UNITS

Four-bolt flange, square design
FPL2

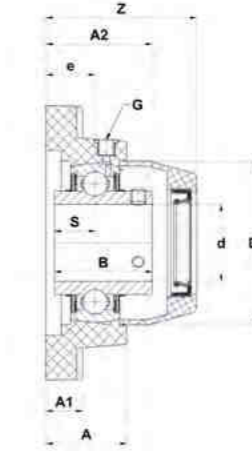
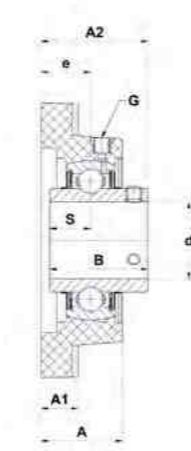
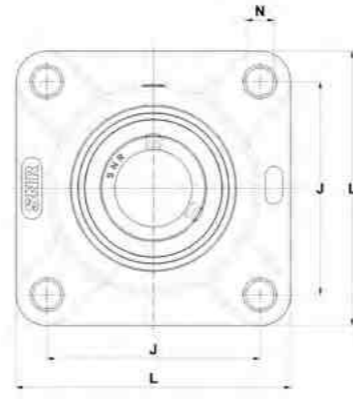

Main dimensions [mm]

d	Unit	L	J	N	A	A1	A2	e	S	B	G	Z	Dz	Housing	Bearing insert	Open protective cap	Closed protective cap	Dynamic load rating C [kN]	Static load rating C0 [kN]	Weight [kg]	d
20	MUCFPL204	86	63,5	11	27,8	13,4	36,3	18	12,7	31	1/4"-28	48,2	50	FPL204	MUC204FD	CV204	CF204	10,9	5,3	0,3	20
25	MUCFPL205	95	70	11	28	14,3	36,8	17	14,3	34,1	1/4"-28	50,1	55	FPL205	MUC205FD	CV205	CF205	11,9	6,3	0,4	25
30	MUCFPL206	107	83	11	31,5	14,3	41,4	19,2	15,9	38,1	1/4"-28	58,7	64	FPL206	MUC206FD	CV206	CF206	16,7	9,0	0,5	30
35	MUCFPL207	118	92	13	34,8	15,5	46,9	21,5	17,5	42,9	1/4"-28	63,6	74,5	FPL207	MUC207FD	CV207	CF207	22,0	12,3	0,7	35
40	MUCFPL208	130	102	14	37,5	17	53,2	23	19	49,2	1/4"-28	71	84	FPL208	MUC208FD	CV208	CF208	24,9	14,3	1,0	40

FLANGED UNITS

Two-bolt flange, oval design
NFL2

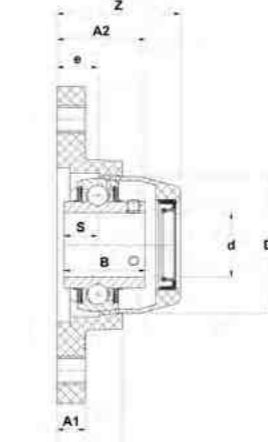
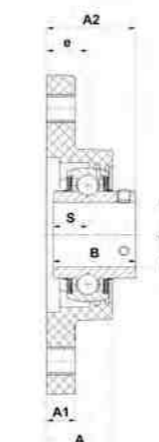
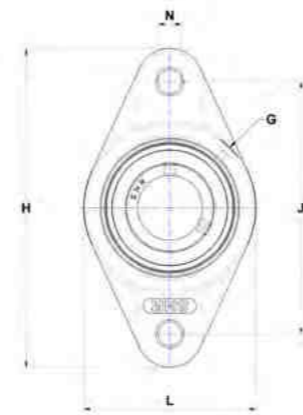

Main dimensions [mm]

d	Unit	H	J	L	N	A	A1	A2	e	S	B	G	G	Z	Dz	Housing	Bearing insert	Open protective cap	Closed protective cap	Dynamic load rating C [kN]	Static load rating C0 [kN]	Weight [kg]	d
20	MUCNFL204	113	90	64,8	11	26,5	11,4	33,7	15,4	12,7	31	1/4"-28	1/4-28 UNF	46,8	50	NFL204	MUC204FD	CV204	CF204	10,9	5,3	0,3	20
25	MUCNFL205	130	99	70	11	29,1	13,5	36,8	17	14,3	34,1	1/4"-28	1/4-28 UNF	51,1	55	NFL205	MUC205FD	CV205	CF205	11,9	6,3	0,3	25
30	MUCNFL206	148	117	80	11	30,5	13,3	41,2	19	15,9	38,1	1/4"-28	1/4-28 UNF	57,5	64	NFL206	MUC206FD	CV206	CF206	16,7	9,0	0,5	30
35	MUCNFL207	163	130	90	13	32,8	16,1	43,4	18	17,5	42,9	1/4"-28	1/4-28 UNF	61,6	74,5	NFL207	MUC207FD	CV207	CF207	22,0	12,3	0,7	35
40	MUCNFL208	175	144	100	14	37,5	20	51,7	21,5	19	49,2	1/4"-28	1/4-28 UNF	71	84	NFL208	MUC208FD	CV208	CF208	24,9	14,3	0,9	40

THERMOPLASTIC HOUSINGS WITH STAINLESS STEEL BEARING INSERTS

FLANGED UNITS

Three-bolt flange
FBL2

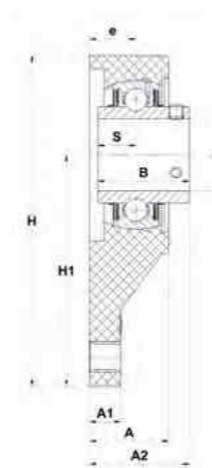
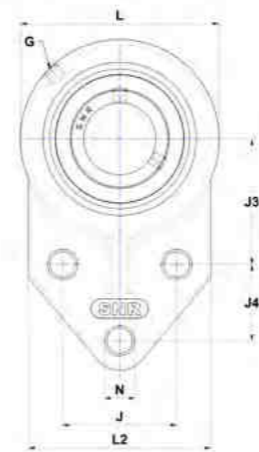

MUCFBL

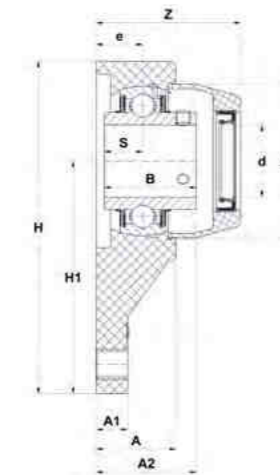

MUCFBL + protective cap

Main dimensions [mm]

d	Unit	H	H1	L	L2	J	J3	J4	N	A	A1	A2	e	S	B	G	Z	Dz	Housing	Bearing insert	Open protective cap	Closed protective cap	Dynamic load rating C [kN]	Static load rating C0 [kN]	Weight [kg]	d
20	MUCFBL204	108	76,2	63,5	62	38,1	42,9	22,2	10,7	26,5	11,4	33,7	15,4	12,7	31	1/4"-28	46,8	50	FBL204	MUC204FD	CV204	CF204	10,9	5,3	0,26	20
25	MUCFBL205	120,6	85,7	70	63,5	41,3	46	28,6	10,7	34	11,4	41,6	21,8	14,3	34,1	1/4"-28	56,2	55	FBL205	MUC205FD	CV205	CF205	11,9	6,3	0,3	25
30	MUCFBL206	138,5	96,5	83	76	47,6	52,4	31,8	10,7	32	13,3	41,5	19,3	15,9	38,1	1/4"-28	58,9	64	FBL206	MUC206FD	CV206	CF206	16,7	9	0,3	30
35	MUCFBL207	157	109,5	95	89	50,8	60,3	31,8	13,1	36,5	16,1	47,1	21,7	17,5	42,9	1/4"-28	65,1	74,5	FBL207	MUC207FD	CV207	CF207	22	12,3	0,66	35
40	MUCFBL208	158,5	109,5	99	89	50,8	60,3	31,8	13,1	36	16	51,7	21,5	19	49,2	1/4"-28	69,5	84	FBL208	MUC208FD	CV208	CF208	24,9	14,3	0,62	40

BEARING INSERTS FOR FOOD-PROCESSING

Wide version with food grade grease filling **SUC2**

Wide version with food grade solid grease (LUBSOLID) filling **SUC2..FG1**

Wide version with food grade grease filling **MUC2..FD**

Coated version for food applications **ZUC2..FG**

Narrow version with food grade grease filling **SES2**

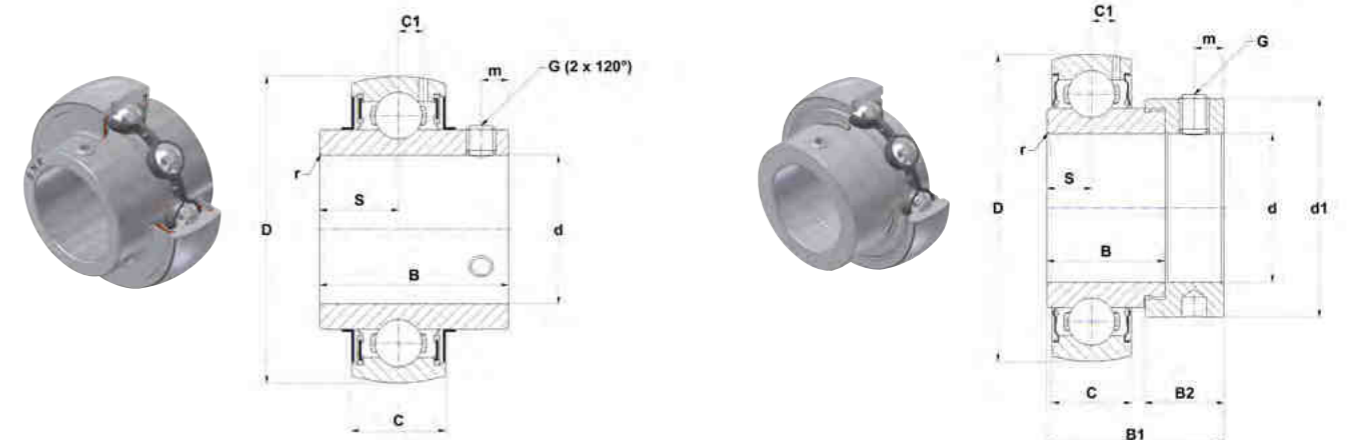

SUC, SUC..FG1, MUC..FD, ZUC..FG

SES

Main dimensions [mm]

d	Bearing insert	D	C	B	B1	B2	d1	S	m	C1	r min	G	SW**	Set screw torque [Nm]	min Temp [°C]	max Temp [°C]	Dynamic load rating C [kN]	Static load rating C0 [kN]	Weight [kg]	d
12	SES201	40	12	19,1	28,6	13,5	28,6	6	5	3,4	0,5	M6x1	3	3,9	-20	100	7,8	4,5	0,1	12
	SUC201	47	17	31	-	-	-	12,7	5	3,7	0,5	M6x1	3	3,9	-20	100	10,1	6,8	0,2	12
15	SES202	40	12	19,1	28,6	13,5	28,6	6	5	3,4	0,5	M6x1	3	3,9	-20	100	7,8	4,5	0,1	15
	SUC202	47	17	31	-	-	-	12,7	5	3,7	0,5	M6x1	3	3,9	-20	100	10,1	6,8	0,2	15
17	SES203	40	12	19,1	28,6	13,5	28,6	6	5	3,4	0,5	M6x1	3	3,9	-20	100	7,8	4,5	0,1	17
	SUC203	47	17	31	-	-	-	12,7	5	3,7	0,5	M6x1	3	3,9	-20	100	10,1	6,8	0,2	17
20	MUC204FD	47	17	31	-	-	-	12,7	4,5	4,5	1,5	M6x1	3	3,9	-20	100	10,9	5,3	0,2	20
	SES204	47	14	21,5	31	13,5	33,3	7	5	3,7	0,5	M6x1	3	3,9	-20	100	10,1	6,8	0,2	20
	SUC204	47	17	31	-	-	-	12,7	5	3,7	0,5	M6x1	3	3,9	-20	100	10,1	6,8	0,2	20
	SUC204FG1*	47	17	31	-	-	-	12,7	5	-	0,5	M6x1	3	3,9	-10	80	10,1	6,8	0,2	20
	ZUC204FG	47	16	31	-	-	-	12,7	4,7	4,4	0,6	M6x1	3	5,5	-20	100	12,8	6,7	0,2	20
25	MUC205FD	52	17	34,1	-	-	-	14,3	5	4,5	1,5	M6x1	3	3,9	-20	100	11,9	6,3	0,2	25
	SES205	52	15	21,5	31	13,5	38,1	7,5	5	3,9	0,5	M6x1	3	3,9	-20	100	11,0	8,0	0,2	25
	SUC205	52	17	34,1	-	-	-	14,3	5	3,9	0,5	M6x1	3	3,9	-20	100	11,0	8,0	0,2	25
	SUC205FG1*	52	17	34,1	-	-	-	14,3	5	-	0,5	M6x1	3	3,9	-10	80	11,0	8,0	0,2	25
	ZUC205FG	52	17	34	-	-	-	14,3	5,5	4,3	0,6	M6x1	3	5,5	-20	100	14,0	7,9	0,2	25
30	MUC206FD	62	19	38,1	-	-	-	15,9	5	5,1	1,5	M6x1	3	3,9	-20	100	16,7	9,0	0,3	30
	SES206	62	16	23,8	35,7	15,9	44,5	8	6	5	0,5	M8x1	4	8,3	-20	100	15,3	11,5	0,3	30
	SUC206	62	19	38,1	-	-	-	15,9	5	5	0,5	M6x1	3	3,9	-20	100	15,3	11,5	0,3	30
	SUC206FG1*	62	19	38,1	-	-	-	15,9	5	-	0,5	M6x1	3	3,9	-10	80	15,3	11,5	0,3	30
	ZUC206FG	62	19	38,1	-	-	-	15,9	5,5	5	0,6	M6x1	3	5,5	-20	100	19,5	11,2	0,3	30
35	MUC207FD	72	20	42,9	-	-	-	17,5	6	5,8	2	M8x1	4	8,3	-20	100	22,0	12,3	0,5	35
	SES207	72	17	25,4	38,9	17,5	55,6	8,5	6,5	5,7	1	M8x1	4	8,3	-20	100	20,1	15,6	0,5	35
	SUC207	72	20	42,9	-	-	-	17,5	6,5	5,7	1	M8x1	4	8,3	-20	100	20,1	15,6	0,5	35
	SUC207FG1*	72	20	42,9	-	-	-	17,5	6,5	-	1	M8x1	4	8,3	-10	80	20,1	15,6	0,4	35
	ZUC207FG	72	20	42,9	-	-	-	17,5	6,5	5,8	1,1	M8x1	4	11,5	-20	100	25,8	15,2	0,5	35
40	MUC208FD	80	21	49,2	-	-	-	19	8	6,2	2	M8x1	4	8,3	-20	100	24,9	14,3	0,6	40
	SES208	80	18	30,2	43,7	18,3	60,3	9	6,5	6,2	1	M8x1	4	8,3	-20	100	22,8	18,2	0,6	40
	SUC208	80	21	49,2	-	-	-	19	8	6,2	1	M8x1	4	8,3	-20	100	32,0	19,3	0,6	40
	SUC208FG1*	80	21	49,2	-	-	-	19	8	-	1	M8x1	4	8,3	-10	80	32,0	19,3	0,6	40
	ZUC208FG	80	21	49,2	-	-	-	19	8	6,3	1,1	M8x1	4	11,5	-20	100	29,6	18,2	0,7	40
45	SES209	85	19	30,2	43,7	18,3	63,5	9,5	6,5	6,4	1	M8x1	4	8,3	-20	100	25,7	20,8	0,7	45
	SUC209	85	22	49,2	-	-	-	19	8	6,4	1	M8x1	4	8,3	-20	100	25,7	20,8	0,7	45
	SUC209FG1*	85	22	49,2	-	-	-	19	8	-	1	M8x1	4	8,3	-10	80	25,7	20,8	0,6	45
50	SES210	90	20	30,2	43,7	18,3	69,9	10	6,5	6,5	1	M8x1	4	8,3	-20	100	27,5	23,7	0,8	50
	SUC210	90	24	51,6	-	-	-	19	10	6,5	1	M10x1,25	5	18,7	-20	100	27,5	23,7	0,8	50
	SUC210FG1*	90	24	51,6	-	-	-	19	10	-	1	M10x1,25	5	18,7	-10	80	27,5	23,7	0,7	50
55	SES211	100	21	32,5	48,4	20,7	76,2	10,5	8	7	1	M10x1,25	5	18,7	-20	100	34,0	25,5	1,0	55
	SUC211	100	25	55,6	-	-	-	22,2	10	7	1	M10x1,25	5	18,7	-20	100	34,0	25,5	1,1	55
60	SES212	110	22	37,1	53,1	22,3	84,2	11	8	7,6	1	M10x1,25	5	18,7	-20	100	41,0	31,5	1,3	60
	SUC212	110	27	65,1	-	-	-	25,4	10	7,6	1	M10x1,25	5	18,7	-20	100	41,0	31,5	1,5	60

* LUBSOLID®

** Largeur (douille hexagonale)

BEARING INSERTS FOR FOOD-PROCESSING

Wide version with food grade grease filling **SUC2**

Wide version with food grade solid grease (LUBSOLID) filling **SUC2..FG1**

Wide version with food grade grease filling **MUC2..FD**

Coated version for food applications **ZUC2..FG**

Narrow version with food grade grease filling **SES2**

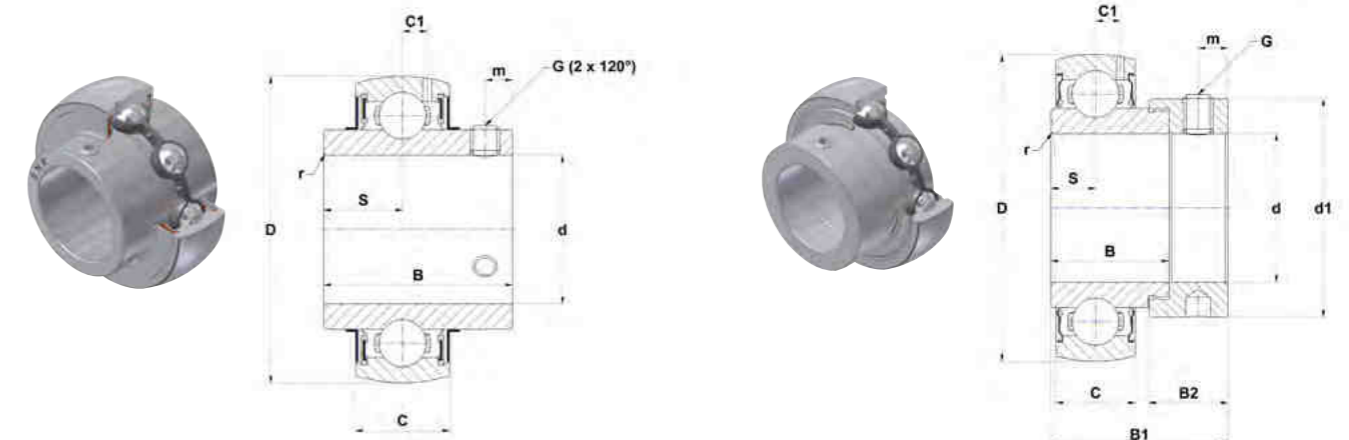

SUC, SUC..FG1, MUC..FD, ZUC..FG

SES

Main dimensions [mm]

d [inch]	d [mm]	Bearing insert	D	C	B	B1	B2	d1	S	m	C1	r min	G	SW**	Set screw torque [Nm]	min Temp [°C]	max Temp [°C]	Dynamic load rating C [kN]	Static load rating C0 [kN]	Weight [kg]	d [inch]
1/2	12,7	SUC201-08	47	17	31	-	-	-	12,7	5,0	3,7	0,5	M6x1	3 mm	3,9	-20	100	10,1	6,8	0,2	1/2
		SUC201-08FG1*	47	17	31	-	-	-	12,7	5,0	-	0,5	M6x1	3	3,9	-10	80	10,1	6,8	0,2	
5/8	15,875	MUC202-10FD	47	17	31	-	-	-	12,7	4,5	4,5	1	1/4-28UNF	1/8	3,9	-20	100	10,9	5,3	0,2	5/8
		SUC202-10	47	17	31	-	-	-	12,7	5,0	3,7	0,5	M6x1	3 mm	3,9	-20	100	10,1	6,8	0,2	
		SUC202-10FG1*	47	17	31	-	-	-	12,7	5,0	-	0,5	M6x1	3 mm	3,9	-10	80	10,1	6,8	0,2	
3/4	19,05	MUC204-12FD	47	17	31	-	-	-	12,7	4,5	4,5	1,5	1/4-28UNF	1/8	3,9	-20	100	10,9	5,3	0,2	3/4
		SES204-12	47	14	21,5	31	13,5	33,3	7	5,0	3,7	0,5	1/4-28UNF	1/8	3,9	-20	100	10,1	6,8	0,2	
		SUC204-12	47	17	31	-	-	-	12,7	5,0	3,7	0,5	1/4-28UNF	1/8	3,9	-20	100	10,1	6,8	0,2	
		SUC204-12FG1*	47	17	31	-	-	-	12,7	5,0	-	0,5	1/4-28UNF	1/8	3,9	-10	80	10,1	6,8	0,2	
		ZUC204-12FG	47	16	31	-	-	-	12,7	4,7	4,4	0,6	1/4-28UNF	1/8	3,7	-20	100	12,8	6,7	0,2	
7/8	22,225	SUC205-14	52	17	34,1	-	-	-	14,3	5,0	3,9	0,5	1/4-28UNF	1/8	3,9	-20	100	11,0	8,0	0,2	7/8
15/16	23,813	SUC205-15	52	17	34,1	-	-	-	14,3	5,0	3,9	0,5	1/4-28UNF	1/8	3,9	-20	100	11,0	8,0	0,2	15/16
1	25,4	MUC205-16FD	52	17	34,1	-	-	-	14,3	5,0	4,5	1,5	1/4-28UNF	1/8	3,9	-20	100	11,9	6,3	0,2	1
		SES205-16	52	15	21,5	31	13,5	38,1	7,5	5,0	3,9	0,5	1/4-28UNF	1/8	3,9	-20	100	11,0	8,0	0,2	
		SUC205-16	52	17	34,1	-	-	-	14,3	5,0	3,9	0,5	1/4-28UNF	1/8	3,9	-20	100	11,0	8,0	0,2	
		SUC205-16FG1*	52	17	34,1	-	-	-	14,3	5,0	-	0,5	1/4-28UNF	1/8	3,9	-10	80	11,0	8,0	0,2	
		ZUC205-16FG	52	17	34	-	-	-	14,3	5,5	4,3	0,6	1/4-28UNF	1/8	3,7	-20	100	14,0	7,9	0,2	
1 1/8	28,575	MUC206-18FD	62	19	38,1	-	-	-	15,9	5,0	5,1	1,5	1/4-28UNF	1/8	3,9	-20	100	16,7	9,0	0,3	1 1/8
1 3/16	30,163	MUC206-19FD	62	19	38,1	-	-	-	15,9	5,0	5,1	1,5	1/4-28UNF	1/8	3,9	-20	100	16,7	9,0	0,3	1 3/16
		SES206-19	62	16	23,8	35,7	15,9	44,5	8	6,0	5,0	0,5	5/16-24UNF	5/32	8,3	-20	100	15,3	11,5	0,3	
		SUC206-19	62	19	38,1	-	-	-	15,9	5,0	5,0	0,5	1/4-28UNF	1/8	3,9	-20	100	15,3	11,5	0,3	
		SUC206-19FG1*	62	19	38,1	-	-	-	15,9	5,0	-	0,5	1/4-28UNF	1/8	3,9	-10	80	15,3	11,5	0,3	
		ZUC206-19FG	62	19	38,1	-	-	-	15,9	5,5	5,0	0,6	1/4-28UNF	1/8	3,7	-20	100	19,5	11,2	0,3	
1 1/4	31,75	MUC206-20FD	62	19	38,1	-	-	-	15,9	5,0	5,1	1,5	1/4-28UNF	1/8	3,9	-20	100	16,7	9,0	0,3	1 1/4
		MUC207-20FD	72	20	42,9	-	-	-	17,5	6,0	5,8	2	5/16-24UNF	5/32	8,3	-20	100	22,0	12,3	0,5	
		SES206-20	62	16	23,8	35,7	15,9	44,5	8	6,0	5,0	0,5	5/16-24UNF	5/32	8,3	-20	100	15,3	11,5	0,3	
		SUC206-20	62	19	38,1	-	-	-	15,9	5,0	5,0	0,5	1/4-28UNF	1/8	3,9	-20	100	15,3	11,5	0,3	
		SUC206-20FG1*	62	19	38,1	-	-	-	15,9	5,0	-	0,5	1/4-28UNF	1/8	3,9	-10	80	15,3	11,5	0,3	
		SUC207-20	72	20	42,9	-	-	-	17,5	6,5	5,7	1,5	5/16-24UNF	5/32	8,3	-20	100	20,1	15,6	0,5	
		SUC207-20FG1*	72	20	42,9	-	-	-	17,5	6,5	-	1,5	5/16-24UNF	5/32	8,3	-10	80	20,1	15,6	0,4	
		ZUC206-20FG	62	19	38,1	-	-	-	15,9	5,5	5,0	0,6	1/4-28UNF	1/8	3,7	-20	100	19,5	11,2	0,3	
		ZUC207-20FG	72	20	42,9	-	-	-	17,5	6,5	5,8	1,1	5/16-24UNF	5/32	8	-20	100	25,8	15,2	0,5	
1 5/16	33,338	SUC207-21	72	20	42,9	-	-	-	17,5	6,5	5,7	1	5/16-24UNF	5/32	8,3	-20	100	20,1	15,6	0,5	1 5/16

* LUBSOLID®

** * Largeur (douille hexagonale)

BEARING INSERTS FOR FOOD-PROCESSING

Wide version with food grade grease filling **SUC2**

Wide version with food grade solid grease (LUBSOLID) filling **SUC2..FG1**

Wide version with food grade grease filling **MUC2..FD**

Coated version for food applications **ZUC2..FG**

Narrow version with food grade grease filling **SES2**

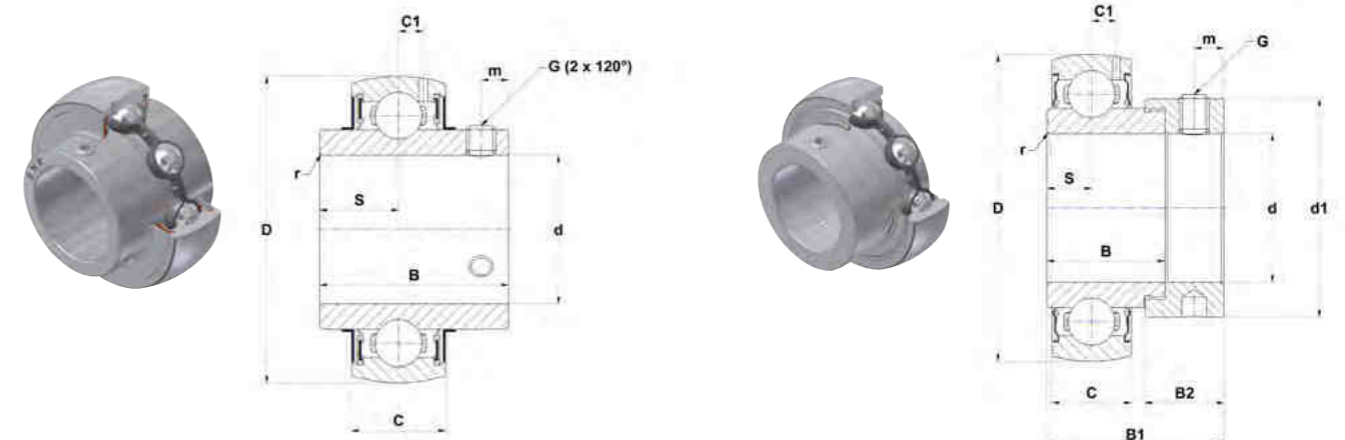

SUC, SUC..FG1, MUC..FD, ZUC..FG

SES

Main dimensions [mm]

d [inch]	d [mm]	Bearing insert	D	C	B	B1	B2	d1	S	m	C1	r min	G	SW**	Set screw torque [Nm]	min Temp [°C]	max Temp [°C]	Dynamic load rating C [kN]	Static load rating C0 [kN]	Weight [kg]	d [inch]
1 3/8	34,925	MUC207-22FD	72	20	42,9	-	-	-	17,5	6,0	5,8	2	5/16-24UNF	5/32	8,3	-20	100	22,0	12,3	0,5	1 3/8
		SES207-22	72	17	25,4	38,9	17,5	55,6	8,5	6,5	5,7	1	5/16-24UNF	5/32	8,3	-20	100	20,1	15,6	0,5	
		SUC207-22	72	20	42,9	-	-	-	17,5	6,5	5,7	1	5/16-24UNF	5/32	8,3	-20	100	20,1	15,6	0,5	
		SUC207-22FG1*	72	20	42,9	-	-	-	17,5	6,5	-	1	5/16-24UNF	5/32	8,3	-10	80	20,1	15,6	0,4	
1 7/16	36,513	MUC207-23FD	72	20	42,9	-	-	-	17,5	6,0	5,8	2	5/16-24UNF	5/32	8,3	-20	100	22,0	12,3	0,5	1 7/16
		SES207-23	72	17	25,4	38,9	17,5	55,6	8,5	6,5	5,7	1	5/16-24UNF	5/32	8,3	-20	100	20,1	15,6	0,5	
		SUC207-23	72	20	42,9	-	-	-	17,5	6,5	5,7	1	5/16-24UNF	5/32	8,3	-20	100	20,1	15,6	0,5	
		SUC207-23FG1*	72	20	42,9	-	-	-	17,5	6,5	-	1	5/16-24UNF	5/32	8,3	-10	80	20,1	15,6	0,4	
1 1/2	38,1	ZUC207-23FG	72	20	42,9	-	-	-	17,5	6,5	5,8	1,1	5/16-24UNF	5/32	8	-20	100	25,8	15,2	0,5	
		MUC208-24FD	80	21	49,2	-	-	-	19	8,0	6,2	2	5/16-24UNF	5/32	8,3	-20	100	24,9	14,3	0,6	1 1/2
		SES208-24	80	18	30,2	43,7	18,3	60,3	9	6,5	6,2	1	5/16-24UNF	5/32	8,3	-20	100	22,8	18,2	0,6	
		SUC208-24	80	21	49,2	-	-	-	19	8,0	6,2	1	5/16-24UNF	5/32	8,3	-20	100	32,0	19,3	0,6	
1 11/16	42,863	SUC208-24FG1*	80	21	49,2	-	-	-	19	8,0	-	1	5/16-24UNF	5/32	8,3	-10	80	32,0	19,3	0,6	
		ZUC208-24FG	80	21	49,2	-	-	-	19	8,0	6,3	1,1	5/16-24UNF	5/32	8	-20	100	29,6	18,2	0,7	
		SUC209-27	85	22	49,2	-	-	-	19	8,0	6,4	1	5/16-24UNF	5/32	8,3	-20	100	25,7	20,8	0,7	1 11/16
		SES209-28	85	19	30,2	43,7	18,3	63,5	9,5	6,5	6,4	1	5/16-24UNF	5/32	8,3	-20	100	25,7	20,8	0,7	1 3/4
1 3/4	44,45	SUC209-28	85	22	49,2	-	-	-	19	8,0	6,4	1	5/16-24UNF	5/32	8,3	-20	100	25,7	20,8	0,7	
		SUC209-28FG1*	85	22	49,2	-	-	-	19	8,0	-	1	5/16-24UNF	5/32	8,3	-10	80	25,7	20,8	0,6	
		SUC210-30	90	24	51,6	-	-	-	19	10,0	6,5	1	3/8-24UNF	3/16	18,7	-20	100	27,5	23,7	0,8	1 7/8
1 7/8	47,625	SES210-31	90	20	30,2	43,7	18,3	69,9	10	6,5	6,5	1	5/16-24UNF	5/32	8,3	-20	100	27,5	23,7	0,8	1 15/16
		SUC210-31	90	24	51,6	-	-	-	19	10,0	6,5	1	3/8-24UNF	3/16	18,7	-20	100	27,5	23,7	0,8	
		SUC210-31FG1*	90	24	51,6	-	-	-	19	10,0	-	1	3/8-24UNF	3/16	18,7	-10	80	27,5	23,7	0,7	
2	50,8	SES211-32	100	21	32,5	48,4	20,7	76,2	10,5	8,0	7,0	1	3/8-24UNF	3/16	18,7	-20	100	34,0	25,5	1,0	2
		SUC210-32	90	24	51,6	-	-	-	19	10,0	6,5	1	3/8-24UNF	3/16	18,7	-20	100	27,5	23,7	0,7	
		SUC211-32	100	25	55,6	-	-	-	22,2	10,0	7,0	1	3/8-24UNF	3/16	18,7	-20	100	34,0	25,5	1,1	
		SUC211-32FG1*	100	25	55,6	-	-	-	22,2	10,0	-	1	3/8-24UNF	3/16	18,7	-10	80	34,0	25,5	1,0	
2 3/16	55,563	SUC211-35	100	25	55,6	-	-	-	22,2	10,0	7,0	1	3/8-24UNF	3/16	18,7	-20	100	34,0	25,5	1,1	2 3/16
		SUC211-35FG1*	100	25	55,6	-	-	-	22,2	10,0	-	1	3/8-24UNF	3/16	18,7	-10	80	34,0	25,5	1,0	
2 7/16	61,913	SUC212-39	110	27	65,1	-	-	-	25,4	10,0	7,6	1	3/8-24UNF	3/16	18,7	-20	100	41,0	31,5	1,5	2 7/16
		SUC212-39FG1*	110	27	65,1	-	-	-	25,4	10,0	-	1	3/8-24UNF	3/16	18,7	-10	80	41,0	31,5	1,4	

* LUBSOLID®

** * Largeur (douille hexagonale)

PROTECTIVE COVERS AND PROTECTIVE CAPS

PROTECTIVE COVERS SCO / SCC

In combination with ball bearing inserts type UC, SUC, ZUC, US, CS, LK and UK

Open cover	Closed cover	d [mm]	Dz	Bz
SCO204-12	SCC204	12	46	14,3
SCO204-15	SCC204	15	46	14,3
SCO204-17	SCC204	17	46	14,3
SCO204-20	SCC204	20	54	14,3
SCO205-25	SCC205	25	60	15,4
SCO206-30	SCC206	30	70	16,9
SCO207-35	SCC207	35	80	18,7
SCO208-40	SCC208	40	88	22,9
SCO209-45	SCC209	45	95	22,9
SCO210-50	SCC210	50	100	25,8
SCO211-55	SCC211	55	110	25,1
SCO212-60	SCC212	60	120	30,4
SCO213-65	SCC213	65	132	29,4

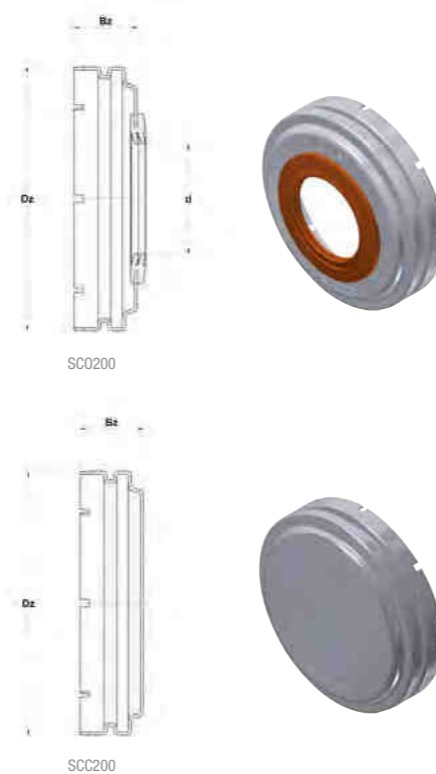

PROTECTIVE COVERS SCOE / SCCE

In combination with ball bearing inserts type EX, ES and SES

Open cover	Closed cover	d [mm]	Dz	Bz
SCOE201-12	SCCE203	12	46	21
SCOE202-15	SCCE203	15	46	21
SCOE203-17	SCCE203	17	46	21
SCOE204-20	SCCE204	20	54	23,5
SCOE205-25	SCCE205	25	60	24
SCOE206-30	SCCE206	30	70	26
SCOE207-35	SCCE207	35	80	28
SCOE208-40	SCCE208	40	88	29
SCOE209-45	SCCE209	45	95	30
SCOE210-50	SCCE210	50	100	33,5
SCOE211-55	SCCE211	55	110	38,5
SCOE212-60	SCCE212	60	120	41
SCOE213-65	SCCE213	65	132	44

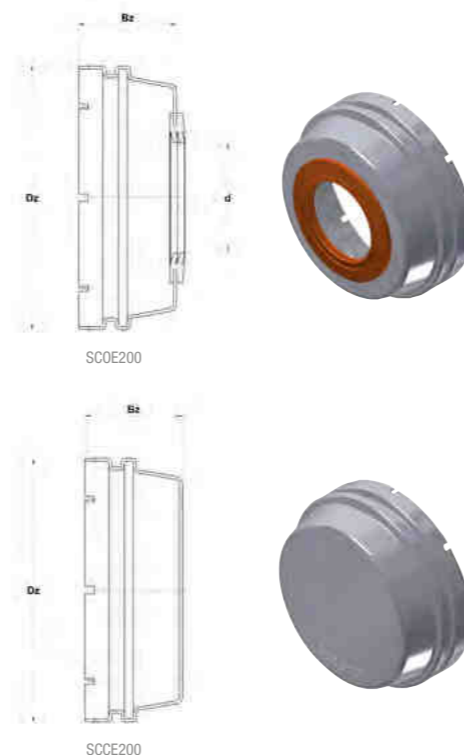

PROTECTIVE COVERS SCOU

(INCH SHAFTS)

Open cover	d [mm]	Dz	Bz
SCOU201-08	1/2	46	21
SCOU202-10	5/8	46	21
SCOU203-11	11/16	46	21
SCOU204-12	3/4	54	23,5
SCOU205-14	7/8	60	24
SCOU205-15	15/16	60	24
SCOU205-16	1	60	24
SCOU206-18	1 1/8	70	26
SCOU206-19	1 3/16	70	26
SCOU206-20	1 1/4	70	26
SCOU207-20	1 1/4	80	28
SCOU207-21	1 5/16	80	28
SCOU207-22	1 3/8	80	28
SCOU207-23	1 7/16	80	28

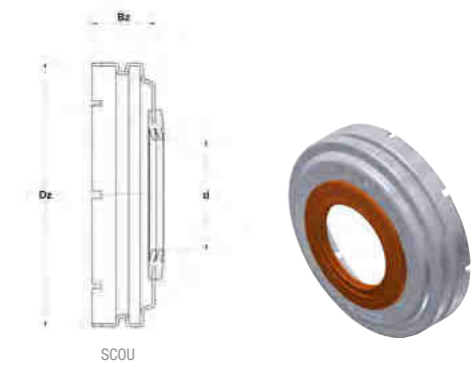

Open cover	d [mm]	Dz	Bz
SCOU208-24	1 1/2	88	29
SCOU208-25	1 9/16	88	29
SCOU209-26	1 5/8	95	30
SCOU209-27	1 11/16	95	30
SCOU209-28	1 3/4	95	30
SCOU210-30	1 7/8	100	33,5
SCOU210-31	1 15/16	100	33,5
SCOU211-32	2	110	38,5
SCOU211-34	2 1/8	110	38,5
SCOU211-35	2 3/16	110	38,5
SCOU212-36	2 1/4	120	41
SCOU212-38	2 3/8	120	41
SCOU212-39	2 7/16	120	41
SCOU213-40	2 1/2	132	44

PROTECTIVE CAPS PCO / PCC

Protective caps for bearing units from cast iron (ISO series)

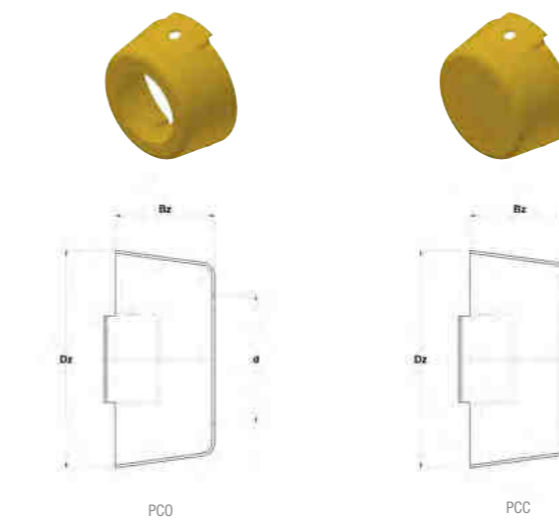

Open cover	Closed cover	d [mm]	Dz	Bz
PCO204	PCC204	20	43	23
PCO205	PCC205	25	49	23
PCO206	PCC206	30	58	27
PCO207	PCC207	35	68	29
PCO208	PCC208	40	76	31

PROTECTIVE CAPS CV / CF

Protective caps for bearing units from thermoplastic

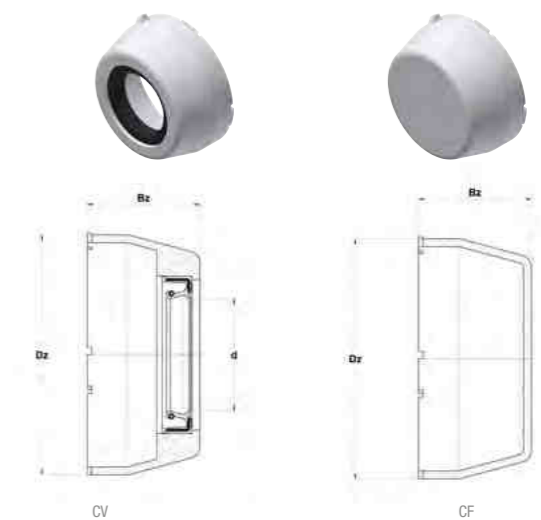

Open cover	Closed cover	d [mm]	Dz	Bz
CV204	CF204	20	50	23
CV205	CF205	25	55	25
CV206	CF206	30	64	30
CV207	CF207	35	75	32
CV208	CF208	40	84	37

Summary



SELF-ALIGNING BEARING UNITS

Accessible quality

This document is the exclusive property of NTN-SNR ROULEMENTS. Any total or partial reproduction hereof without the prior consent of NTN-SNR ROULEMENTS is strictly prohibited. Legal action may be brought against anyone breaching the terms of this paragraph.

NTN-SNR ROULEMENTS shall not be held liable for any errors or omissions that may have crept into this document despite the care taken in drafting it. Due to our policy of continuous research and development, we reserve the right to make changes without notice to all or part of the products and specifications mentioned in this document.

© NTN-SNR ROULEMENTS, international copyright 2021.

