

FAG



Deep Groove Ball Bearings FAG Generation C

Single row

SCHAEFFLER

Single row deep groove ball bearings Generation C

	Page
Product overview	Single row deep groove ball bearings Generation C..... 2
Features	Advantages 4
	Sealing 4
	Operating temperature..... 6
	Cages 6
	Suffixes 6
Design and safety guidelines	Equivalent dynamic bearing load 7
	Equivalent static bearing load 8
	Axial load carrying capacity..... 8
	Minimum radial load..... 9
	Speed..... 9
	Mounting dimensions 9
Accuracy	Dimensional and running tolerances 10
	Radial internal clearance of bearings with cylindrical bore 10
Dimension tables	Deep groove ball bearings, Generation C, single row, open or sealed 12

Product overview Single row deep groove ball bearings Generation C

Open

60...-C
62...-C
63...-C



60...-C-TVH
62...-C-TVH
63...-C-TVH



Gap seals

60...-C-2Z
62...-C-2Z
63...-C-2Z

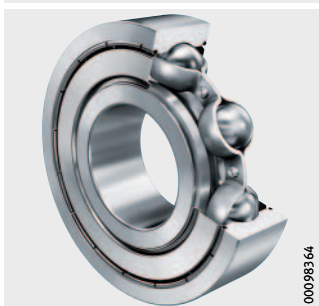

60...-C-2Z-TVH
62...-C-2Z-TVH
63...-C-2Z-TVH

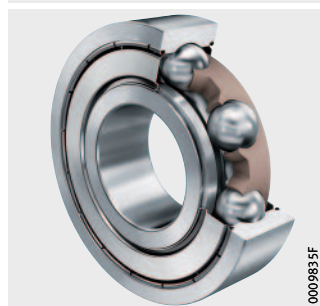

Lip seals

60..-C-2HRS
62..-C-2HRS
63..-C-2HRS

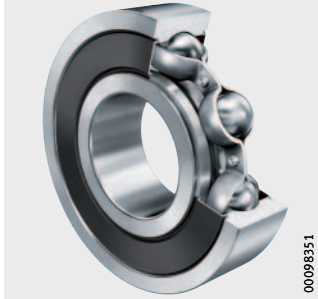

60..-C-2HRS-TVH
62..-C-2HRS-TVH
63..-C-2HRS-TVH

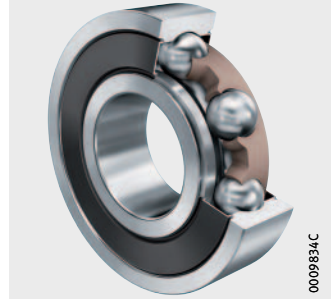

60..-C-2ELS
62..-C-2ELS
63..-C-2ELS



60..-C-2ELS-TVH
62..-C-2ELS-TVH
63..-C-2ELS-TVH

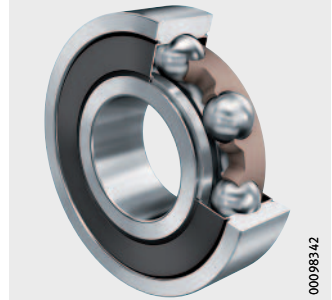

Non-contact seals

60..-C-2BRS
62..-C-2BRS
63..-C-2BRS

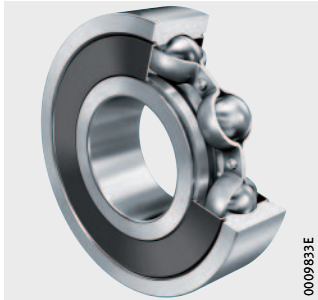

60..-C-2BRS-TVH
62..-C-2BRS-TVH
63..-C-2BRS-TVH

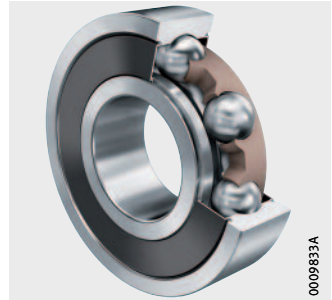

Single row deep groove ball bearings Generation C

Features	<p>Single row deep groove ball bearings are versatile, self-retaining bearings with solid outer rings, inner rings and ball and cage assemblies. They are of a simple design, robust in operation and easy to maintain. They are available in open and sealed designs. Due to the raceway geometry and the use of balls, deep groove ball bearings can support axial forces in both directions as well as radial forces.</p> <p>Deep groove ball bearings of Generation C were specially developed with a focus on low noise levels and low frictional torque. They are particularly suitable, for example, for use in electrical machinery, ventilators, washing machines and power tools.</p>
Advantages	<p>Thanks to design modifications such as improved bearing kinematics, new seals and cages as well as refined manufacturing processes, deep groove ball bearings of Generation C have numerous advantages.</p>
Lower noise levels	<p>The bearing is quieter in operation due to the better quality of the balls, the optimised surfaces, the higher stability of the cage and the modified internal construction.</p>
Improved sealing	<p>Efficient protection against the escape of grease or the ingress of dust is provided by the innovative gap seal design (suffix Z). Even better sealing is achieved in the bearings with a lip seal running under axial contact, <i>Figure 1</i>, page 5, ③ and ④ (suffix HRS or ELS). This is due to the seal design and the labyrinth function as a result of the matched undercuts in the outer ring and inner ring.</p>
Lower friction	<p>The friction in the bearing is reduced by modified osculation and optimisation of surfaces, waviness and roundness.</p>
Higher cost-effectiveness	<p>Due to the lower friction, energy costs for operation are reduced. The reduced grease loss, better protection against contamination and reduced strain on the lubricant extend the grease operating life and thus the rating life of the bearing.</p>
Sealing	<p>Open bearings are suitable for high to very high speeds. Due to the manufacturing process, they have turned recesses for sealing washers and sealing shields, <i>Figure 1</i>, page 5, ①.</p> <p>Bearings with the suffix 2Z have gap seals on both sides, <i>Figure 1</i>, page 5, ②. These bearings are greased using a high quality grease, lubricated for life and suitable for high speeds. In comparison with conventional gap seals, the inverted sealing shield design gives improved sealing action.</p>

Bearings with the suffix 2HRS or 2ELS have lip seals on both sides made from nitrile butadiene rubber, *Figure 1* ③ and ④. They are greased using a high quality grease, lubricated for life and suitable for moderate speeds. In comparison with lip seals running under radial contact, higher speeds can be achieved. At the same time, the frictional torque and heat generation are lower.

Bearings with the suffix 2BRS have non-contact seals on both sides made from nitrile butadiene rubber. The operating temperature is restricted by the seal material, see section Operating temperature, page 6. Their friction level is as low as with the gap seals. In addition, they offer better protection against the ingress of dust and the escape of lubricant, *Figure 1* ⑤.

As lip seals, deep groove ball bearings of Generation C are supplied as standard with the seal HRS. The seal ELS is available by agreement.

- ① Open bearing
- ② New gap seal on both sides (2Z)
- ③ Lip seal on both sides (2HRS)
- ④ Lip seal on both sides (2ELS)
- ⑤ Non-contact seal on both sides (2BRS)

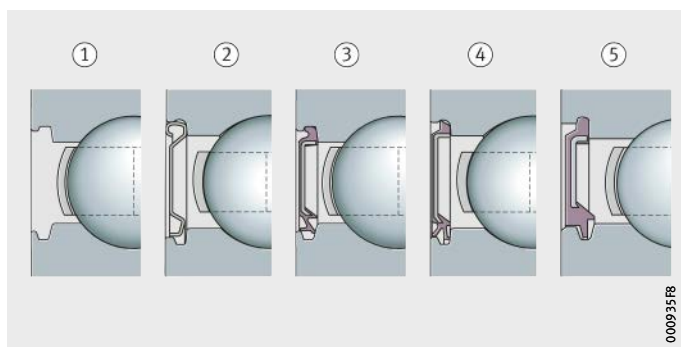

Figure 1
Available designs

Characteristics of sealing variants

Characteristic	Suffix for seal			
	Non-contact		Contact	
	Z	BRS	ELS	HRS
Frictional torque	+++	+++	+	o
Speeds	+++	+++	o	o
Sealing effect against ingress of water	-	o	++	++
Sealing effect against ingress of dust	o	+	+++	++
Sealing effect against escape of grease	o	+	+++	++
Compensation of pressure	+++	+++	+	+

Definition of symbols

- +++ Excellent
- ++ Very good
- + Good
- o Satisfactory
- Unsatisfactory

Single row deep groove ball bearings Generation C

Operating temperature Operating temperatures for various sealing materials

Suffix	Temperature range	
Open bearings	up to +120 °C	If > +120 °C, please contact us
Z	-30 °C to +120 °C	If > +120 °C, please contact us
HRS	-30 °C to +110 °C	Temperature restricted by seal material
ELS	-30 °C to +110 °C	
BRS	-30 °C to +110 °C	
TVH	-30 °C to +120 °C	Temperature restricted by cage material

Suffixes for bearings for high temperatures

Suffix	S1	S2	S3	S4
Max. operating temperature	+200 °C	+250 °C	+300 °C	+350 °C

Cages

Single row deep groove ball bearings of Generation C without a cage suffix have a riveted sheet metal cage.

Suffixes

Suffixes for available designs, see table.

Available designs

Suffix	Description	Design
C	Modified internal construction in Generation C	Standard
2Z	Gap seal on both sides	
2HRS	Lip seal on both sides	
2BRS	Labyrinth seal on both sides	
Z	Gap seal on one side	Special design, available by agreement only
HRS	Lip seal on one side	
ELS	Lip seal on one side	
2ELS	Lip seal on both sides	
BRS	Labyrinth seal on one side	
TVH	Solid polyamide snap cage, ball-guided	



Check the chemical resistance of the polyamide to synthetic greases as well as to lubricants with EP additives.

Aged oil and additives in the oil can impair the operating life of plastic cages at high temperatures. The oil change intervals must be observed.

Further information

- Information on the technical principles of rolling bearing arrangements can be found in our Catalogues HR 1, Rolling Bearings and GL 1, Large Size Bearings.

Design and safety guidelines
Equivalent dynamic bearing load

The equivalent dynamic load P is valid for bearings that are subjected to radial and axial dynamic loads. It gives the same rating life as the combined bearing load occurring in practice.

For bearings under dynamic loading, the following applies:

Load ratio and equivalent dynamic load

Load ratio	Equivalent dynamic bearing load
$\frac{F_a}{F_r} \leq e$	$P = F_r$
$\frac{F_a}{F_r} > e$	$P = X \cdot F_r + Y \cdot F_a$

F_a N
 Axial dynamic bearing load
 F_r N
 Radial dynamic bearing load
 e, X, Y –
 Factors, see table Factors e, X and Y
 P N
 Equivalent dynamic bearing load for combined load.

The factors e, X and Y required for determining P are dependent on the ratio $f_0 \cdot F_a / C_{0r}$ and the radial internal clearance.

The values in the table are valid for normal fits:

- shaft machined to j5 or k5, housing machined to J6.

Factors e, X and Y

$\frac{f_0 \cdot F_a}{C_{0r}}$	Factor for radial internal clearance								
	CN (Group N)			C3 (Group 3)			C4 (Group 4)		
	e	X	Y	e	X	Y	e	X	Y
0,3	0,22	0,56	2	0,32	0,46	1,7	0,4	0,44	1,4
0,5	0,24	0,56	1,8	0,35	0,46	1,56	0,43	0,44	1,31
0,9	0,28	0,56	1,58	0,39	0,46	1,41	0,45	0,44	1,23
1,6	0,32	0,56	1,4	0,43	0,46	1,27	0,48	0,44	1,16
3	0,36	0,56	1,2	0,48	0,46	1,14	0,52	0,44	1,08
6	0,43	0,56	1	0,54	0,46	1	0,56	0,44	1

f_0 –
 Factor, see table, page 8
 F_a N
 Axial dynamic bearing load
 C_{0r} N
 Basic static load rating, see dimension table.

Single row deep groove ball bearings Generation C

Factor f_0
for deep groove ball bearings

Bore code	Factor f_0		
	Series 60	Series 62	Series 63
00	12,4	12,1	11,3
01	13	12,3	11,1
02	13,9	13,1	12,1
03	14,3	13,1	12,3
04	13,9	13,1	12,4
05	14,5	13,8	12,4
06	14,8	13,8	13
07	14,8	13,8	13,1
08	15,3	14	13
09	15,4	14,3	13
10	15,6	14,3	13

Equivalent static bearing load

The equivalent static load P_0 is valid for bearings that are subjected to radial and axial static loads. It induces the same load, at the centre point of the most heavily loaded contact point between the rolling element and raceway, as the combined bearing load occurring in practice.

For bearings under static loading, the following applies:

Load ratio and
equivalent static load

Load ratio	Equivalent static load
$\frac{F_{0a}}{F_{0r}} \leq 0,8$	$P_0 = F_{0r}$
$\frac{F_{0a}}{F_{0r}} > 0,8$	$P_0 = 0,6 \cdot F_{0r} + 0,5 \cdot F_{0a}$

F_{0a} N
Axial static bearing load

F_{0r} N
Radial static bearing load

P_0 N
Equivalent static bearing load for combined load.

Axial load carrying capacity



Deep groove ball bearings are also suitable for axial loads.

If the bearing is subjected to high loads and high speeds, a reduction in rating life as well as an increase in friction and bearing temperature must be taken into consideration.

Minimum radial load

In order to ensure slippage-free operation, the bearings must be subjected to a minimum radial load. This applies particularly in the case of high speeds and high accelerations. In continuous operation, a minimum radial load of the order of $P/C_r > 0,01$ is necessary for ball bearings with cage.

Speed

The limiting speed n_G indicates the speed range within which the bearing can be used without the need for special precautions. In the case of bearings with increased running accuracy, the limiting speed n_G can be exceeded under certain circumstances.

The following influencing factors are significant here:

- cage design
- cage material
- lubricant
- lubrication method
- internal clearance
- machining of the bearing seats
- bearing load
- heat dissipation.

If the limiting speed n_G is exceeded, we recommend checking with Schaeffler Application Engineering to determine whether the necessary conditions will be fulfilled at these higher speeds.

Mounting dimensions

The dimension tables give the maximum dimension of the radius r_a and the diameters of the abutment shoulders D_a and d_a .



Bearings of Generation C may exhibit differences in diameter of the dimensions D_2 and d_2 compared to the standard bearings described in Catalogue HR 1, Rolling Bearings.

Single row deep groove ball bearings Generation C

Accuracy The main dimensions of the standardised single row deep groove ball bearings correspond to DIN 625-1 (ISO 15).

Dimensional and running tolerances The dimensional and running tolerances of the standardised bearings correspond to tolerance class 6 in accordance with ISO 492:2014.

Bearings with a higher accuracy are available by agreement.

Radial internal clearance of bearings with cylindrical bore The radial internal clearance corresponds to internal clearance group CN (Group N) in accordance with DIN 620-4 (ISO 5753-1).

Radial internal clearance

Bore d mm		Radial internal clearance							
		C2 (Group 2) µm		CN (Group N) µm		C3 (Group 3) µm		C4 (Group 4) µm	
over	incl.	min.	max.	min.	max.	min.	max.	min.	max.
6	10	0	7	2	13	8	23	14	29
10	18	0	9	3	18	11	25	18	33
18	24	0	10	5	20	13	28	20	36
24	30	1	11	5	20	13	28	23	41
30	40	1	11	6	20	15	33	28	46
40	50	1	11	6	23	18	36	30	51

Radial internal clearance CM for electric motors

Bore d mm		Radial internal clearance CM µm	
over	incl.	min.	max.
10	18	4	11
18	30	5	12
30	50	9	17

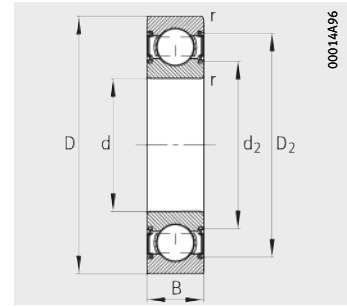
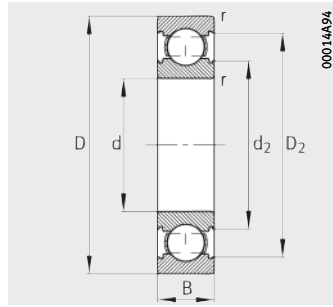

Figure 2
Deep groove ball bearings
of Generation C

000936A0

Deep groove ball bearings Generation C

Single row
Open or sealed



Seal 2HRS

Dimension table · Dimensions in mm

Designation	Mass m ≈ kg	Dimensions					
		d	D	B	r	D ₂	d ₂
					min.	≈	≈
629-C	0,02	9	26	8	0,3	23,4	13,4
629-C-2HRS	0,021	9	26	8	0,3	23,4	13,4
629-C-2Z(-2BRS)	0,021	9	26	8	0,3	23,4	13,4
6000-C	0,019	10	26	8	0,3	23,4	13,4
6000-C-2HRS	0,02	10	26	8	0,3	23,4	13,4
6000-C-2Z(-2BRS)	0,02	10	26	8	0,3	23,4	13,4
6200-C	0,031	10	30	9	0,6	26	14,9
6200-C-2HRS	0,034	10	30	9	0,6	26	14,9
6200-C-2Z(-2BRS)	0,032	10	30	9	0,6	26	14,9
6001-C	0,02	12	28	8	0,3	25,4	15,41
6001-C-2HRS	0,022	12	28	8	0,3	25,4	15,41
6001-C-2Z(-2BRS)	0,02	12	28	8	0,3	25,4	15,41
6201-C	0,037	12	32	10	0,6	28,2	17
6201-C-2HRS	0,039	12	32	10	0,6	28,2	17
6201-C-2Z(-2BRS)	0,039	12	32	10	0,6	28,2	17
6301-C	0,062	12	37	12	1	32,2	17,8
6301-C-2HRS	0,064	12	37	12	1	32,2	17,8
6301-C-2Z(-2BRS)	0,064	12	37	12	1	32,2	17,8
6002-C	0,031	15	32	9	0,3	29	18,9
6002-C-2HRS	0,033	15	32	9	0,3	29	18,9
6002-C-2Z(-2BRS)	0,033	15	32	9	0,3	29	18,9
6202-C	0,043	15	35	11	0,6	31,2	19,8
6202-C-2HRS	0,045	15	35	11	0,6	31,2	19,8
6202-C-2Z(-2BRS)	0,045	15	35	11	0,6	31,2	19,8
6203-C	0,065	17	40	12	0,6	35,2	22,6
6203-C-2HRS	0,067	17	40	12	0,6	35,2	22,6
6203-C-2Z(-2BRS)	0,067	17	40	12	0,6	35,2	22,6
6004-C	0,069	20	42	12	0,6	37,7	25,1
6004-C-2HRS	0,071	20	42	12	0,6	37,7	25,1
6004-C-2Z(-2BRS)	0,071	20	42	12	0,6	37,7	25,1
6204-C	0,106	20	47	14	1	41,4	26,5
6204-C-2HRS	0,11	20	47	14	1	41,4	26,5
6204-C-2Z(-2BRS)	0,11	20	47	14	1	41,4	26,5

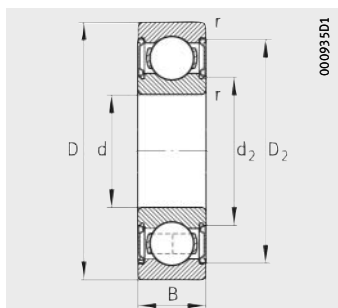

Seal 2Z (2BRS)

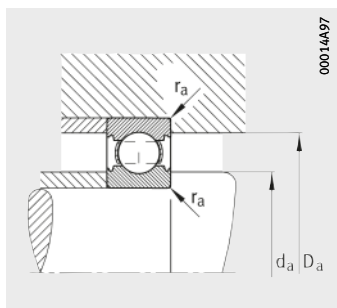

Mounting dimensions
Open design

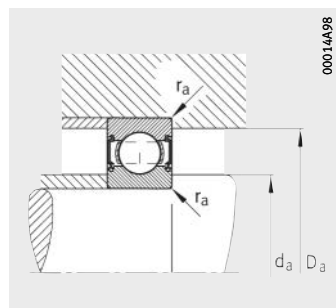

Mounting dimensions
Sealed design

Mounting dimensions			Basic load ratings		Fatigue limit load C_{ur} N	Limiting speed n_G min^{-1}	Reference speed n_B min^{-1}
d_a min.	D_a max.	r_a max.	dyn. C_r N	stat. C_{0r} N			
11,4	23,6	0,3	5 000	1 970	133	44 500	28 500
11,4	23,6	0,3	5 000	1 970	133	28 600	–
11,4	23,6	0,3	5 000	1 970	133	38 000	28 500
12	24	0,3	5 000	1 970	133	44 500	30 000
12	24	0,3	5 000	1 970	133	28 600	–
12	24	0,3	5 000	1 970	133	38 000	30 000
14,2	25,8	0,6	6 600	2 600	177	40 500	26 000
14,2	25,8	0,6	6 600	2 600	177	25 700	–
14,2	25,8	0,6	6 600	2 600	177	34 500	26 000
14	26	0,3	5 500	2 360	158	42 500	26 000
14	26	0,3	5 500	2 360	158	24 800	–
14	26	0,3	5 500	2 360	158	36 000	26 000
16,2	27,8	0,6	7 600	3 100	208	37 000	24 600
16,2	27,8	0,6	7 600	3 100	208	22 400	–
16,2	27,8	0,6	7 600	3 100	208	31 500	24 600
17,6	31,4	1	10 900	4 200	280	31 000	20 000
17,6	31,4	1	10 900	4 200	280	21 700	–
17,6	31,4	1	10 900	4 200	280	26 500	20 000
17	30	0,3	6 000	2 850	171	37 000	23 300
17	30	0,3	6 000	2 850	171	20 200	–
17	30	0,3	6 000	2 850	171	31 500	23 300
19,2	30,8	0,6	8 400	3 750	250	33 000	22 400
19,2	30,8	0,6	8 400	3 750	250	19 300	–
19,2	30,8	0,6	8 400	3 750	250	28 000	22 400
21,2	35,8	0,6	10 400	4 750	320	29 000	20 100
21,2	35,8	0,6	10 400	4 750	320	16 900	–
21,2	35,8	0,6	10 400	4 750	320	24 600	20 100
23,2	38,8	0,6	10 000	5 000	305	27 500	19 800
23,2	38,8	0,6	10 000	5 000	305	15 200	–
23,2	38,8	0,6	10 000	5 000	305	23 200	19 800
25,6	41,4	1	13 900	6 600	445	24 300	18 100
25,6	41,4	1	13 900	6 600	445	14 400	–
25,6	41,4	1	13 900	6 600	445	20 600	18 100

Deep groove ball bearings Generation C

Single row
Open or sealed

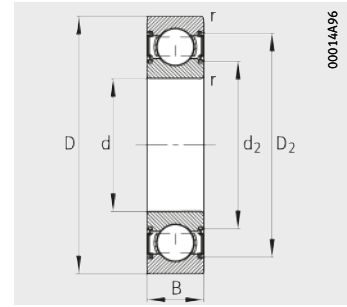
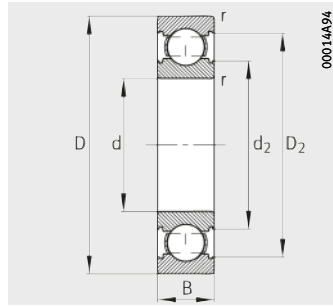

Seal 2HRS

Dimension table (continued) - Dimensions in mm

Designation	Mass m ≈ kg	Dimensions					
		d	D	B	r min.	D ₂ ≈	d ₂ ≈
6205-C	0,129	25	52	15	1	46,4	31,3
6205-C-2HRS	0,133	25	52	15	1	46,4	31,3
6205-C-2Z(-2BRS)	0,133	25	52	15	1	46,4	31,3
6305-C	0,215	25	62	17	1,1	54	34
6305-C-2HRS	0,224	25	62	17	1,1	54	34
6305-C-2Z(-2BRS)	0,222	25	62	17	1,1	54	34
6206-C	0,195	30	62	16	1	55,4	37,4
6206-C-2HRS	0,201	30	62	16	1	55,4	37,4
6206-C-2Z(-2BRS)	0,201	30	62	16	1	55,4	37,4
6306-C	0,328	30	72	19	1,1	63,4	41,3
6306-C-2HRS	0,34	30	72	19	1,1	63,4	41,3
6306-C-2Z(-2BRS)	0,339	30	72	19	1,1	63,4	41,3
6207-C	0,263	35	72	17	1,1	64,7	44,5
6207-C-2HRS	0,274	35	72	17	1,1	64,7	44,5
6207-C-2Z(-2BRS)	0,273	35	72	17	1,1	64,7	44,5
6307-C	0,434	35	80	21	1,5	69,8	46
6307-C-2HRS	0,449	35	80	21	1,5	69,8	46
6307-C-2Z(-2BRS)	0,447	35	80	21	1,5	69,8	46
6208-C	0,345	40	80	18	1,1	70,7	49,2
6208-C-2HRS	0,359	40	80	18	1,1	70,7	49,2
6208-C-2Z(-2BRS)	0,359	40	80	18	1,1	70,7	49,2
6308-C	0,6	40	90	23	1,5	78,8	52,1
6308-C-2HRS	0,622	40	90	23	1,5	78,8	52,1
6308-C-2Z(-2BRS)	0,617	40	90	23	1,5	78,8	52,1
6209-C	0,396	45	85	19	1,1	75,5	53,9
6209-C-2HRS	0,413	45	85	19	1,1	75,5	53,9
6209-C-2Z(-2BRS)	0,411	45	85	19	1,1	75,5	53,9
6210-C	0,431	50	90	20	1,1	81,8	59,1
6210-C-2HRS	0,451	50	90	20	1,1	81,8	59,1
6210-C-2Z(-2BRS)	0,448	50	90	20	1,1	81,8	59,1

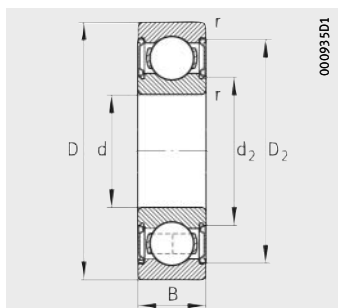

Seal 2Z (2BRS)

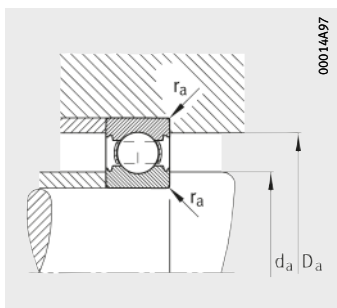

Mounting dimensions
Open design

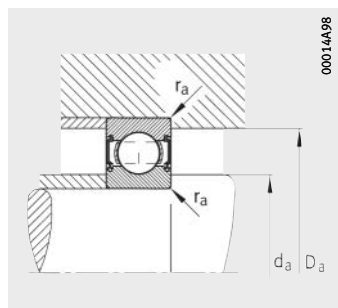

Mounting dimensions
Sealed design

Mounting dimensions			Basic load ratings		Fatigue limit load C_{ur}	Limiting speed n_G	Reference speed n_B
d_a min.	D_a max.	r_a max.	dyn. C_r N	stat. C_{0r} N			
30,6	46,4	1	15 000	7 800	485	21 600	16 100
30,6	46,4	1	15 000	7 800	485	12 200	–
30,6	46,4	1	15 000	7 800	485	18 400	16 100
32	55	1	24 700	11 500	780	17 800	13 500
32	55	1	24 700	11 500	780	11 300	–
32	55	1	24 700	11 500	780	15 100	13 500
35,6	56,4	1	20 800	11 200	700	17 800	13 400
35,6	56,4	1	20 800	11 200	700	10 200	–
35,6	56,4	1	20 800	11 200	700	15 100	13 400
37	65	1	32 000	16 200	1 090	15 100	11 800
37	65	1	32 000	16 200	1 090	9 300	–
37	65	1	32 000	16 200	1 090	12 800	11 800
42	65	1	28 000	15 400	1 030	15 000	11 500
42	65	1	28 000	15 400	1 030	8 600	–
42	65	1	28 000	15 400	1 030	12 700	11 500
44	71	1,5	37 000	19 100	1 290	13 600	10 900
44	71	1,5	37 000	19 100	1 290	8 300	–
44	71	1,5	37 000	19 100	1 290	11 500	10 900
47	73	1	31 500	17 800	1 200	13 600	10 400
47	73	1	31 500	17 800	1 200	7 800	–
47	73	1	31 500	17 800	1 200	11 600	10 400
49	81	1,5	47 000	25 000	1 690	11 800	9 900
49	81	1,5	47 000	25 000	1 690	7 400	–
49	81	1,5	47 000	25 000	1 690	10 100	9 900
52	78	1	34 000	20 300	1 370	12 700	9 700
52	78	1	34 000	20 300	1 370	7 100	–
52	78	1	34 000	20 300	1 370	10 800	9 700
57	83	1	38 000	23 200	1 540	11 700	9 200
57	83	1	38 000	23 200	1 540	6 400	–
57	83	1	38 000	23 200	1 540	9 900	9 200

Schaeffler Technologies AG & Co. KG

Georg-Schäfer-Straße 30
97421 Schweinfurt
Germany
Internet www.fag.com
E-mail faginfo@schaeffler.com

In Germany:

Phone 0180 5003872
Fax 0180 5003873

From other countries:

Phone +49 9721 91-0
Fax +49 9721 91-3435

Every care has been taken to ensure the correctness of the information contained in this publication but no liability can be accepted for any errors or omissions. We reserve the right to make technical changes.

© Schaeffler Technologies AG & Co. KG
Issued: 2017, May

This publication or parts thereof may not be reproduced without our permission.
TPI 165 GB-D