



# Radial Insert Ball Bearings and Housing Units

Plummer block housing units

Flanged housing units

Take-up housing units

Corrosion-resistant product range

Black Series

Roller chain idler sprocket units

Idler pulley units



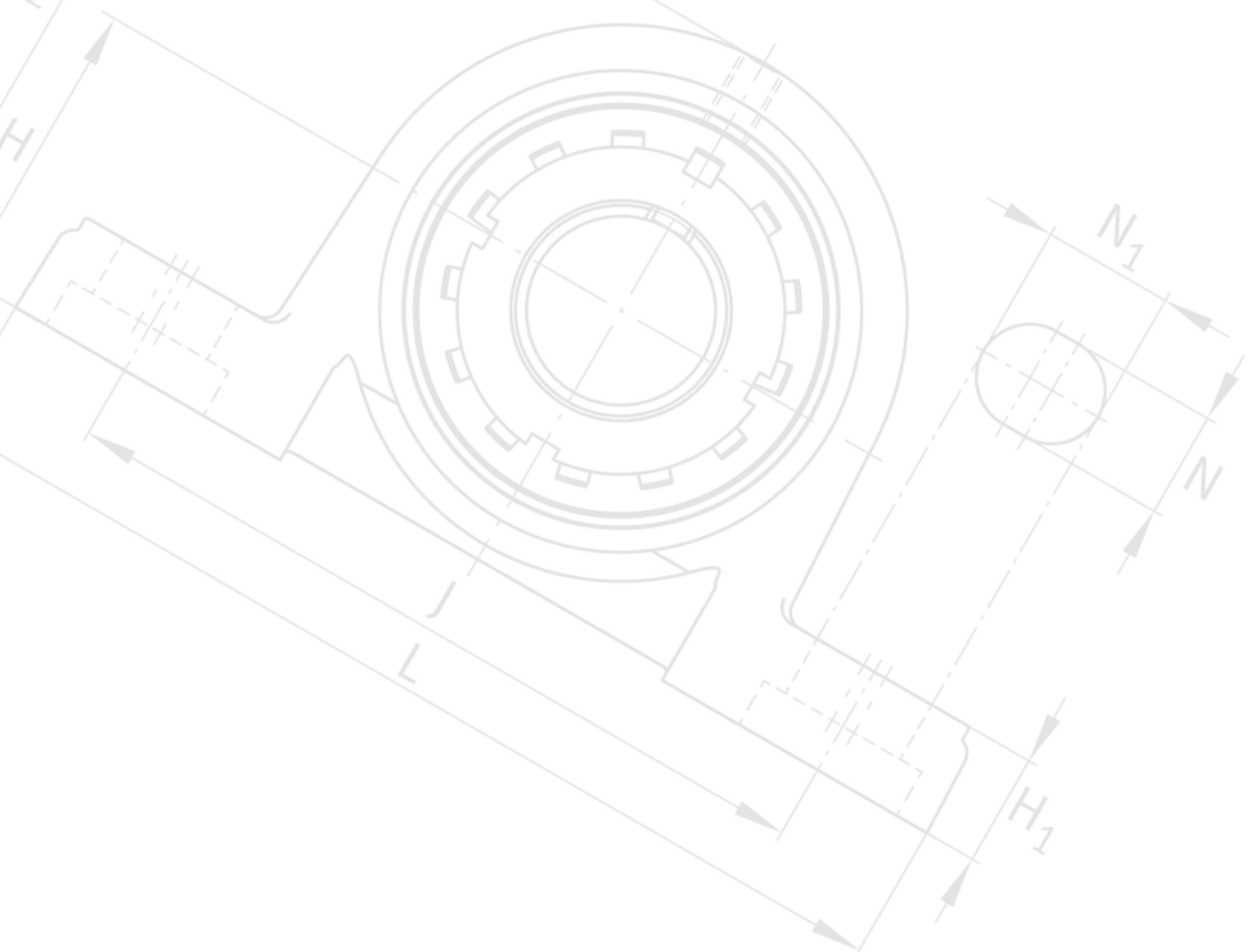

# Radial Insert Ball Bearings and Housing Units

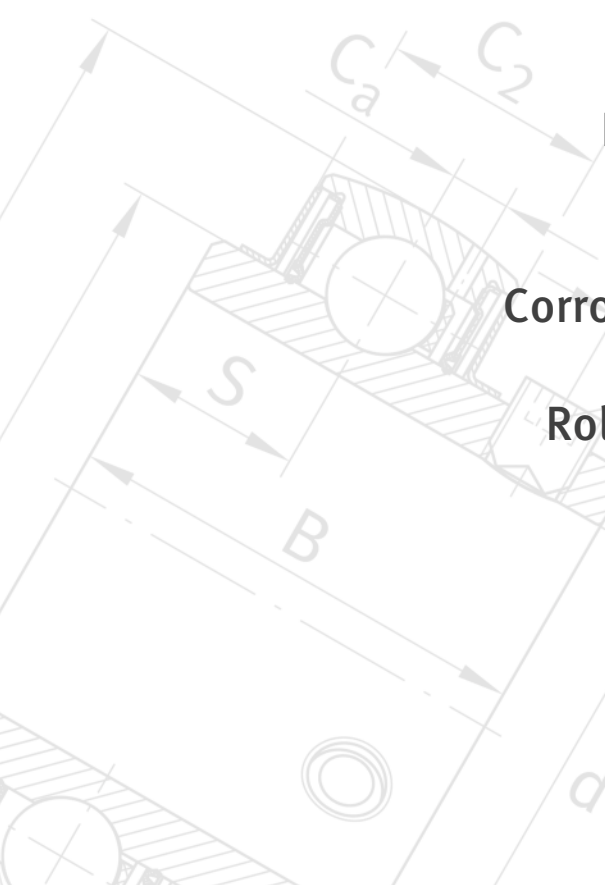

Plummer block housing units

Flanged housing units

Take-up housing units

Corrosion-resistant product range

Black Series

Roller chain idler sprocket units

Idler pulley units

All data have been prepared with a great deal of care and checked for their accuracy. However, no liability can be assumed for any incorrect or incomplete data. We reserve the right to make technical modifications.

© Schaeffler Technologies AG & Co. KG  
Issued: 2017, October

Reproduction in whole or in part without our authorisation is prohibited.

# Foreword

## **Schaeffler Technologies**

Schaeffler Technologies with its brands INA and FAG is a leading worldwide supplier of rolling bearings, spherical plain bearings, plain bearings, linear products, accessories specific to bearings and comprehensive maintenance products and services. Schaeffler has approximately 40 000 catalogue products manufactured as standard, providing an extremely wide portfolio that gives secure coverage of applications from 60 industrial market sectors.

The central factors responsible for this success are our outstanding strength in innovation, our global focus on local customer proximity, highly developed manufacturing methods, extremely high quality standards in all processes and our ability to transform specific customer requirements quickly and accurately into cost-effective solutions. Against this background of expertise, knowledge and experience together with our wide range of catalogue items, we see ourselves as a high performance, customer focussed partner.

## **Research and development**

As a company looking to the future, we are especially active in the field of research and development. The key areas in this respect include not only research into fundamental principles, materials technology, tribology and calculation but also extensive inspection and test methods as well as activities to optimise manufacturing technology. This is oriented towards ensuring the continuous development, improvement and application of our products in the long term.

We carry out research and development on a global basis. Our development centres are linked with each other worldwide and are thus in a position to exchange current information on a very short timescale as well as access and communicate the most recent data. This ensures that a uniform level of knowledge and information is available worldwide.

In addition to continued development of standard products, we work closely in research and development activities with our customers where specific customer solutions are required. They can thus benefit from the best product for their application, with the maximum possible performance capacity at a cost-effective price.

# Foreword

## **Quality, manufacturing technology, environmental protection**

“Zero defects” is our quality objective. We have matched all our processes, both in product development and in manufacturing, to this target.

Our comprehensive know-how in forming, in forging, in heat treatment and surface technologies, in hard machining by means of grinding and honing and in assembly processes is applied in order to ensure that our products fulfil the required quality level.

Our manufacturing processes are monitored by means of systematic quality inspections. This ensures that all products continuously fulfil the same high standard of quality.

All Schaeffler sites worldwide are certified to ISO/TS 16949:2009 and DIN EN ISO 9001:2008.

With the validation and certification of our manufacturing sites, we are taking a pioneering role in environmental protection. All larger manufacturing sites are certified to ISO 14001 and are also validated in accordance with the more stringent EC ECO Management and Audit Scheme (EMAS).

## **Worldwide presence**

Through a closely knit network of development and manufacturing sites, sales companies and an international distribution structure, we are represented throughout the world. This global presence ensures effective linkage between the major markets in Europe, India, South East Asia/Pacific Region, East Asia, North and South America.

As a result, we have an on-site presence with service and technical advice in close proximity to the customer.

We take orders from throughout the world and make deliveries worldwide too. Furthermore, we support our customers worldwide in resolving their bearing arrangement requirements, respond to technical queries and develop specific bearing arrangement solutions in local partnership with our customers.

## **Catalogue SG 1, Radial Insert Ball Bearings and Housing Units**

Radial insert ball bearings and housing units are robust, ready-to-fit machine elements for the design of economical bearing arrangements. These products are available in many different series, have proven effective over many years and predominantly comprise a housing fitted with a radial insert ball bearing. The housing bore and the bearing outer ring have a spherical profile and are matched to each other. This allows the bearing ring in the housing to adapt to static angular misalignment of the shaft.

Due to their special locating methods, principally by eccentric locking collar or grub screws, the radial insert ball bearings can be easily located on the shaft. They are particularly easy to fit when they are used in combination with drawn shafts. Radial insert ball bearings are fitted with multi-piece seals that effectively protect the rolling element set against contamination and moisture, even under difficult and critical operating conditions.

Schaeffler offers a wide range of housing units with radial insert ball bearings. Radial insert ball bearings are based on single row deep groove ball bearings.

## **Radial insert ball bearings**

The outer rings of radial insert ball bearings have a spherical or cylindrical outside surface. Radial insert ball bearings are available with a metric or inch size bore. Black Series radial insert ball bearings with a Durotect BS coating have basic anti-corrosion protection. Corrosion-resistant radial insert ball bearings are available in a high grade steel version or with the Corrotect coating.

## **Housing units**

Housing units are available as plummer block, flanged and take-up housing units in numerous different designs. The units are ready-to-fit and comprise cast iron or sheet steel housings in which radial insert ball bearings are integrated. Corrosion-resistant units are available with the Corrotect coating, in a high grade steel version or made from plastic.

The dimensions of the FAG Black Series housing units with a primer paint coating correspond to JIS B 1557 and have basic anti-corrosion protection due to the Durotect BS coating.

## **Current level of technology**

The data represent the current level of technology and manufacture as of October 2017. They reflect not only progress in bearing arrangement technology but also the experience gathered from numerous applications.

Any data in earlier publications that do not correspond to the data in this catalogue are therefore invalid.

## **Definition of the Attention symbol**

This catalogue predominantly gives descriptions of standard housings. Since these are used in numerous applications, we cannot make a judgement as to whether any malfunctions will cause harm to persons or property.

## **Follow instructions**

It is always and fundamentally the responsibility of the designer and user to ensure that all specifications are observed and that all necessary information is communicated to the end user. This applies in particular to applications in which product failure and malfunction may constitute a hazard to human beings.



If guidelines marked with the Attention symbol are not observed, damage or malfunctions in the product or the adjacent construction may occur.

# Foreword

## **X-life**

X-life is the premium brand that identifies particularly high performance products under the FAG and INA brands. They are characterised by longer rating life and operating life, due to higher basic dynamic load ratings compared to the previous standard.

X-life is an all-encompassing concept: advice, product development, service and sales are fully integrated with each other in all phases of the product cycle. As a service surround system, it includes a comprehensive lubrication concept. In addition, X-life stands for continuous quality improvement and local customer focus applied worldwide.

## **Advantages of X-life quality**

The use of state of the art manufacturing technologies has resulted in a better, more uniform surface over the whole contact face between the rolling elements and raceway. As a result, under identical load there is a significant reduction in the stress conditions present on the rolling elements and raceway. The improved surface quality gives reduced friction and lower bearing temperatures, running resistance is lower and less strain is placed on the lubricant.

Thanks to such improvements, the basic dynamic load ratings are significantly higher than those of the previous design. As a result, the basic rating life is higher; i.e. the operating life of the bearings is considerably longer under the same operating conditions. Alternatively, higher loads can be applied while maintaining the same rating life values.

With their optimised characteristics, X-life bearings open up completely new application prospects, such as downsizing of the bearing arrangement. Furthermore, the improved price/performance ratio ultimately increases the overall cost-effectiveness of the bearing arrangement.

X-life bearings are indicated in the dimension tables.

## **Further information**

■ <http://www.schaeffler.de/X-life>.



***medias professional***  
**electronic information system**

*medias professional*, the proven selection and information system, presents the INA and FAG catalogue products in electronic format. As with the printed catalogue, this gives our customers product information on both brands in a single data source. This saves time and gives easier handling.

*medias professional* is available online and in download form in several languages, is easy to navigate and is particularly clear thanks to the use of numerous images, diagrams and models. There are also highly representative application examples, classified by market sector.

Datasheets on the bearing series can be generated as PDF files. It includes a lubricant database and also the web2CAD link for direct download and integration of 3D models.

*medias professional* focusses on the individual bearing. The complete shaft can be simulated and any influences arising from its deformation on the bearings can be determined using the calculation program BEARINX. This program can also be made available to direct customers as BEARINX-online via the Internet (for conditions, see the INA/FAG homepage).

In conclusion, *medias professional* is a comprehensive, reliable system to help you help yourself answer many questions on rolling bearing technology by electronic means, quickly and at any location.



► <http://medias.schaeffler.de>

## Foreword

### Selection wizard for housing units in *medias professional*

The selection wizard for bearing housings in *medias professional* gives comprehensive assistance in the selection of housings and housing units. It takes account of the environmental conditions and the requirements placed on the bearing arrangement as well as the characteristics of the housings and the bearings suitable for the housings. Once the specified data has been inputted, the software generates detailed lists of results that also contain information on further accessories.



► <http://www.schaeffler.de/std/1B6A>

### *medias* interchange

*medias* interchange is available online and assists in the selection process where rolling bearings or housings from other manufacturers are to be replaced by products of the INA and FAG brands. If a rolling bearing and housing designation is entered in *medias* interchange, this will indicate the manufacturer and INA or FAG designations. A traffic light system will quickly indicate whether and to what extent the INA or FAG part is interchangeable. Green indicates fully interchangeable, yellow indicates conditional interchangeability and red indicates non-interchangeable.



► <http://www.schaeffler.de/std/1B69>

### Other technical publications

This catalogue contains the core range of radial insert ball bearings and housing units of the brands INA and FAG. Furthermore, we develop and manufacture many other products and systems that are of significant interest in terms of technical progress and cost-effectiveness for rotary and linear bearing arrangements as well as for the automotive sector. These are covered in separate technical publications that can be obtained upon request.



► <http://medien.schaeffler.de>

**INA and FAG,  
when it comes to motion**

Catalogue SG 1 stands for pioneering bearing technology, application-focussed advice, the highest product and performance density and continuous development.

The benefits to you:

- selection of products from a vast product range
- the most suitable product in the right place
- worldwide availability of products
- short delivery times
- long term supply capability
- security of planning for the long view
- simplified stockholding
- market-competitive prices
- global service
- comprehensive, application-focussed advice.

**Together  
we move the world**

For us, technical progress means never standing still. In partnership with you, we are continually working on new solutions so that your vision and our technical ideas can continue to become a reality, to your benefit.

With our products and our knowledge, we can together continue to fulfil the challenges of your market in relation to bearing arrangements. To this end, this catalogue is an important instrument.

# Foreword

## Catalogue GK 1 for bearing housings

In addition to the radial insert ball bearings and housing units described in this catalogue, Schaeffler offers a wide range of bearing housings. The bearing housings are subdivided into standard housings and housings for specific industrial and railway applications. Catalogue GK 1, Bearing Housings, describes the range of standard housings and gives essential information on special housings.

### Standard housings

The standard housings comprise split and unsplit plummer block housings, take-up housings and flanged housings.

In the case of split plummer block housings, *Figure 1*, the upper section of the housing can be removed. This gives significantly simpler mounting and maintenance. Unsplit plummer block housings, *Figure 2*, are used where the bearing arrangement is subjected to very high loads.

Take-up housings, *Figure 3*, page 11, were developed specifically for tensioner drum bearing arrangements in belt conveyor plant. There is a yoke-shaped drawbar eye for attachment to the tensioning device.

Flanged housings, *Figure 4*, page 11, have a flange perpendicular to the shaft axis and thus offer the ideal adjacent construction for numerous machines and pieces of equipment where the use of plummer block housings would be too demanding.

- ① Split plummer block housing SNS
- ② Split plummer block housing LOE

*Figure 1*  
Split plummer block housings  
(examples)



- ① Plummer block housing unit VRE3
- ② Unsplit plummer block housing BND

*Figure 2*  
Unsplit plummer block housings  
(examples)



*Figure 3*  
Take-up housing SPA



- ① Flanged housing F112
- ② Flanged housing F5

*Figure 4*  
Flanged housings



## Special housings

Special housings are used in particularly challenging applications where not all the requirements can be fulfilled by the use of standard housings. Apart from specific industrial applications, these are principally applications from the railway sector.

Special housings are developed in close cooperation and consultation with the customer. Schaeffler uses its comprehensive know-how of rolling bearing technology in order to ensure that every housing is optimally matched to the specific application.

Selected examples in Catalogue GK 1 give an insight into the diverse areas of application and possibilities of housings for specific industrial and railway applications.

### Further information

- The complete catalogue range can be found in Catalogue GK 1, Bearing Housings.
- Download and ordering: <http://medien.schaeffler.de>
- Electronic selection wizard for bearing housings: <http://medias.schaeffler.de/medias/ga>.



# Contents

	Page
Product index .....	14
Tab index .....	30
Technical principles.....	32
Radial insert ball bearings .....	143
Radial insert ball bearings with spherical outer ring .....	152
Radial insert ball bearings with cylindrical outer ring .....	194
Radial insert ball bearings with rubber interliner or steel aligning ring .....	212
Housing units.....	223
Housing units with flake graphite cast iron housing .....	226
Housing units with sheet steel housing .....	306
Roller chain idler sprocket units, idler pulley units .....	334
Radial insert ball bearings and housing units, corrosion-resistant .....	349
Radial insert ball bearings, corrosion-resistant .....	352
Flake graphite cast iron or sheet steel housing units, corrosion-resistant.....	376
High grade steel housing units, corrosion-resistant .....	396
Plastic housing units, corrosion-resistant .....	426
Black Series .....	467
Radial insert ball bearings.....	470
Housing units .....	488
Other products .....	551
Tillage and harvesting.....	554
Conveying equipment .....	568
Textile machinery.....	572
Food industry.....	578
Ventilators.....	584
Mounting and maintenance .....	587
Products and services .....	589
Mounting.....	592
Lubrication .....	596
Addresses .....	603

# Product index

	Page
<b>2..-XL-KRR</b>	Deep groove ball bearings with extended inner ring, cylindrical outer ring and R type seal ..... 197
<b>2..-XL-NPP-B</b>	Self-aligning deep groove ball bearings, spherical outer ring, P type seal..... 155
<b>AY..-XL-NPP-B</b>	Radial insert ball bearings, spherical outer ring, grub screws in inner ring and P type seal ..... 154
<b>BE..-XL</b>	Radial insert ball bearings with steel aligning ring, with bore for fit and P type seal, no relubrication facility ..... 214
<b>BS</b>	Back Seal ..... 431
<b>CC</b>	Closed end cap ..... 431
<b>CO</b>	Open end cap ..... 431
<b>CRB..-XL</b>	Radial insert ball bearings with rubber interliner, eccentric locking collar ..... 214
<b>CUGPCTL</b>	Two-bolt flanged housing units, plastic housing, eccentric locking collar and RSR type seal, Corrotect, relubrication facility ..... 430
<b>CUGPF</b>	Four-bolt flanged housing units, plastic housing, eccentric locking collar and RSR type seal, Corrotect, relubrication facility ..... 430
<b>CUGPFL</b>	Two-bolt flanged housing units, plastic housing, eccentric locking collar and RSR type seal, Corrotect, relubrication facility ..... 430
<b>CUGPHE</b>	Take-up housing units, plastic housing, guidance surfaces on both sides, eccentric locking collar and RSR type seal, Corrotect, relubrication facility ..... 430
<b>CUGPP</b>	Plummer block housing units with long base, plastic housing, eccentric locking collar and RSR type seal, Corrotect, relubrication facility ..... 430
<b>CUGPPA</b>	Plummer block housing units with short base, plastic housing, eccentric locking collar and RSR type seal, Corrotect, relubrication facility ..... 430
<b>CUGPT</b>	Take-up housing units, plastic housing, guidance slots on both sides, eccentric locking collar and RSR type seal, Corrotect, relubrication facility ..... 430
<b>CUGSF</b>	Four-bolt flanged housing units, corrosion-resistant housing, eccentric locking collar and RSR type seal, Corrotect, relubrication facility ..... 400



	Page
<b>BUGSFL</b>	Two-bolt flanged housing units, corrosion-resistant housing, eccentric locking collar and RSR type seal, Corrotect, relubrication facility ..... 400
<b>BUGSP</b>	Plummer block housing units with long base, corrosion-resistant housing, eccentric locking collar and RSR type seal, Corrotect, relubrication facility ..... 400
<b>BUGSPA</b>	Plummer block housing units with short base, corrosion-resistant housing, eccentric locking collar and RSR type seal, Corrotect, relubrication facility ..... 400
<b>BUGST</b>	Take-up housing units with guide slot, corrosion-resistant housing, eccentric locking collar and RSR type seal, Corrotect, relubrication facility ..... 401
<b>E..-XL-KLL</b>	Radial insert ball bearings, cylindrical outer ring, eccentric locking collar and L type seal..... 196
<b>E..-XL-KRR</b>	Radial insert ball bearings, cylindrical outer ring, eccentric locking collar and R type seal ..... 196
<b>E..-XL-KRR-B</b>	Radial insert ball bearings, spherical outer ring, eccentric locking collar and R type seal ..... 154
<b>FLCTE..-XL</b>	Two-bolt flanged housing units, cast iron housing, eccentric locking collar and P type seal, no relubrication facility ..... 230
<b>FLCTEY..-XL</b>	Two-bolt flanged housing units, cast iron housing, grub screws in inner ring and P type seal, no relubrication facility ..... 230
<b>G..-KRR-B-AS2/V</b>	Radial insert ball bearings, spherical outer ring, eccentric locking collar and R type seal, inch size bore, relubrication facility..... 156
<b>GAY..-XL-NPP-B</b>	Radial insert ball bearings, spherical outer ring, grub screws in inner ring and P type seal, relubrication facility..... 154
<b>GAY..-NPP-B(-AS2/V)</b>	Radial insert ball bearings, spherical outer ring, grub screws in inner ring and P type seal, inch size bore, relubrication facility, with lubrication holes in outer ring on one side or offset on both sides..... 156
<b>GAY..-XL-NPP-B-FA164</b>	Radial insert ball bearings, spherical outer ring, grub screws in inner ring and P type seal, for high temperatures, relubrication facility ..... 154

# Product index

	Page
<b>GE..-XL-KLL-B</b>	Radial insert ball bearings, spherical outer ring, eccentric locking collar and L type seal, relubrication facility ..... 154
<b>GE..-XL-KRR-B</b>	Radial insert ball bearings, spherical outer ring, eccentric locking collar and R type seal, relubrication facility ..... 154
<b>GE..-XL-KRR-B-2C</b>	Radial insert ball bearings, spherical outer ring, eccentric locking collar and R type seal, flinger shields, relubrication facility..... 154
<b>GE..-XL-KRR-B-FA101</b>	Radial insert ball bearings, spherical outer ring, eccentric locking collar and R type seal, for high and low temperatures, relubrication facility ..... 154
<b>GE..-XL-KRR-B-FA125</b>	Radial insert ball bearings, spherical outer ring, eccentric locking collar and R type seal, Corroctect, relubrication facility ..... 356
<b>GE..-XL-KRR-B-FA164</b>	Radial insert ball bearings, spherical outer ring, eccentric locking collar and R type seal, for high temperatures, relubrication facility ..... 154
<b>GE..-XL-KTT-B</b>	Radial insert ball bearings, spherical outer ring, eccentric locking collar and T type seal, relubrication facility ..... 154
<b>GLCTE..-XL</b>	Two-bolt flanged housing units, cast iron housing, eccentric locking collar and P type seal, relubrication facility ..... 230
<b>GLE..-XL-KRR-B</b>	Radial insert ball bearings, spherical outer ring, drive slot in inner ring and R type seal, relubrication facility ..... 155
<b>GEN..-XL-KRR-B</b>	Radial insert ball bearings, spherical outer ring, eccentric locking collar and R type seal, heavy series, relubrication facility ..... 154
<b>GRA..-XL</b>	Three-bolt or four-bolt flanged housing units, sheet steel housing, eccentric locking collar and P type seal, relubrication facility ..... 309
<b>GRA..-NPP-B-AS2/V</b>	Radial insert ball bearings, spherical outer ring, eccentric locking collar and P type seal, inch size bore, relubrication facility ..... 156

	Page
<b>GRAE..-XL-NPP-B</b>	Radial insert ball bearings, spherical outer ring, eccentric locking collar and P type seal, relubrication facility..... 154
<b>GRAE..-XL-NPP-B-FA125</b>	Radial insert ball bearings, spherical outer ring, eccentric locking collar and P type seal, Corrotect, relubrication facility..... 356
<b>GRRY..-VA</b>	Three-bolt or four-bolt flanged housing units, corrosion-resistant sheet steel housing, corrosion-resistant bearing, grub screws in inner ring and R type seal, relubrication facility..... 380
<b>GSH..-XL-2RSR-B</b>	Radial insert ball bearings, spherical outer ring, adapter sleeve and RSR type seal, relubrication facility..... 155
<b>GVK..-KTT-B-AS2/V</b>	Self-aligning deep groove ball bearings, spherical outer ring, square bore and T type seal, relubrication facility ..... 156
<b>GVKE..-KRR-B</b>	Self-aligning deep groove ball bearings, spherical outer ring, metric square bore and R type seal, relubrication facility ..... 156
<b>GY..-KRR-B-AS2/V</b>	Radial insert ball bearings, spherical outer ring, grub screws in inner ring and R type seal, inch size bore, relubrication facility..... 156
<b>GYE..-XL-KRR-B</b>	Radial insert ball bearings, spherical outer ring, grub screws in inner ring and R type seal, relubrication facility..... 154
<b>H..X</b>	Adapter sleeve for radial insert ball bearings UK, Black Series ..... 486
<b>IBBU..-IA03</b>	Four-bolt flanged housing units, round version, for rolls, no relubrication facility..... 554
<b>IBBU..-IA03</b>	Four-bolt flanged housing units, square version, for rolls, no relubrication facility..... 554
<b>IBBU..-IA03</b>	Four-bolt flanged housing units, round version, for rolls, grub screws in inner ring, no relubrication facility ..... 554
<b>IBBU..-IA04</b>	Flanged housing units, for harvesters, no relubrication facility ..... 555
<b>KASK</b>	End caps for housings with one annular slot, suffix N ..... 233
<b>KSR..-B0</b>	Roller chain idler sprocket units, with radial insert ball bearing..... 336
<b>KSR..-L0</b>	Roller chain idler sprocket units, with deep groove ball bearing ..... 336
<b>KSR..-L0..-22</b>	Roller chain idler sprocket units, plastic sprocket, with deep groove ball bearing ..... 336

# Product index

	Page
<b>LASE...-XL</b>	Plummer block housing units, cast iron housing, eccentric locking collar and L type seal, relubrication facility ..... 229
<b>LCFTRY...-IT</b>	Three-bolt flanged housing units for textile machinery, cast iron housing, grub screws in inner ring and R type seal, relubrication facility ..... 572
<b>LCJT...-XL</b>	Two-bolt flanged housing units, cast iron housing, eccentric locking collar and L type seal, relubrication facility ..... 230
<b>LCJT...-IT</b>	Two-bolt flanged housing units for textile machinery, cast iron housing, eccentric locking collar and L type seal, Corrotect, relubrication facility ..... 572
<b>MSTU...-XL</b>	Take-up housing units, sheet steel housing, eccentric locking collar and P type seal, no relubrication facility ..... 309
<b>PASE...-XL</b>	Plummer block housing units, cast iron housing, eccentric locking collar and P type seal, relubrication facility ..... 229
<b>PASE...-XL-N-FA125</b>	Plummer block housing units, cast iron housing, eccentric locking collar and P type seal, Corrotect, relubrication facility ..... 380
<b>PASEY...-XL</b>	Plummer block housing units, cast iron housing, grub screws in inner ring and P type seal, relubrication facility ..... 229
<b>PASEA...-IC</b>	Plummer block housing units for conveying equipment, cast iron housing, adapter sleeve and P type seal, relubrication facility ..... 568
<b>PB...-XL</b>	Plummer block housing units, sheet steel housing, eccentric locking collar and P type seal, no relubrication facility ..... 308
<b>PBS...-XL</b>	Plummer block housing units, sheet steel housing, eccentric locking collar and P type seal, no relubrication facility ..... 308
<b>PBY...-XL</b>	Plummer block housing units, sheet steel housing, grub screws in inner ring and P type seal, no relubrication facility ..... 308

	Page
PCCJ	Four-bolt flanged housing units, cast iron housing, with centring spigot, double row angular contact ball bearing, P type seal, relubrication facility..... 231
PCF..-XL	Four-bolt flanged housing units, cast iron housing, eccentric locking collar and P type seal, relubrication facility..... 231
PCFT..-XL	Two-bolt flanged housing units, cast iron housing, eccentric locking collar and P type seal, relubrication facility..... 230
PCFTR..-XL	Three-bolt flanged housing units, cast iron housing, eccentric locking collar and P type seal, relubrication facility..... 230
PCJ..-XL	Four-bolt flanged housing units, cast iron housing, eccentric locking collar and P type seal, relubrication facility..... 231
PCJ..-XL-N-FA125	Four-bolt flanged housing units, cast iron housing, eccentric locking collar and P type seal, Corrotect, relubrication facility ..... 380
PCJT..-XL	Two-bolt flanged housing units, cast iron housing, eccentric locking collar and P type seal, relubrication facility..... 230
PCJT..-XL-N-FA125	Two-bolt flanged housing units, cast iron housing, eccentric locking collar and P type seal, Corrotect, relubrication facility ..... 380
PCJTY..-XL	Two-bolt flanged housing units, cast iron housing, grub screws in inner ring and P type seal, relubrication facility..... 230
PCJTZA..-IC	Two-bolt flanged housing units for conveying equipment, cast iron housing, eccentric locking collar and P type seal, relubrication facility..... 568
PCJY..-XL	Four-bolt flanged housing units, cast iron housing, grub screws in inner ring and P type seal, relubrication facility..... 231
PCSK	Four-bolt flanged housing units, plastic housing, eccentric locking collar and P type seal, Corrotect, relubrication facility..... 578
PCSLT..-XL	Two-bolt flanged housing units, sheet steel housing, eccentric locking collar and P type seal, no relubrication facility ..... 309

# Product index

	Page
<b>PCSTK</b>	Two-bolt flanged housing units, plastic housing, eccentric locking collar and P type seal, Corrotect, relubrication facility ..... 578
<b>PE..-XL</b>	Radial insert ball bearings with steel aligning ring, eccentric locking collar and P type seal, no relubrication facility ..... 214
<b>PHE..-XL</b>	Take-up housing units, cast iron housing, eccentric locking collar and P type seal, relubrication facility ..... 232
<b>PHEY..-XL</b>	Take-up housing units, cast iron housing, grub screws in inner ring and P type seal, relubrication facility ..... 232
<b>PHUSE..-XL</b>	Take-up housing units, cast iron and sheet steel, eccentric locking collar and P type seal, relubrication facility ..... 232
<b>PME..-XL</b>	Four-bolt flanged housing units, cast iron housing, with wide centring spigot, eccentric locking collar and P type seal, relubrication facility ..... 231
<b>PMEY..-XL</b>	Four-bolt flanged housing units, cast iron housing, with wide centring spigot, grub screws in inner ring and P type seal, relubrication facility ..... 231
<b>PSFT..-XL</b>	Take-up housing units, cast iron housing, self-aligning, eccentric locking collar and P type seal, relubrication facility ..... 232
<b>PSHE..-XL</b>	Plummer block housing units, cast iron housing, eccentric locking collar and P type seal, relubrication facility ..... 229
<b>PSHEY..-XL</b>	Plummer block housing units, cast iron housing, grub screws in inner ring and P type seal, relubrication facility ..... 229
<b>PTUE..-XL</b>	Take-up housing units, cast iron housing, eccentric locking collar and P type seal, relubrication facility ..... 232
<b>PTUE..-IC</b>	Take-up housing units for conveying equipment, cast iron housing, self-aligning deep groove ball bearing with bore for fit, P type seal, no relubrication facility ..... 568

	Page
<b>PTUEY..-XL</b>	Take-up housing units, cast iron housing, grub screws in inner ring and P type seal, relubrication facility..... 232
<b>RA..-XL</b>	Three-bolt or four-bolt flanged housing units, sheet steel housing, eccentric locking collar and P type seal, no relubrication facility ..... 309
<b>RA..-NPP</b>	Radial insert ball bearings, cylindrical outer ring, eccentric locking collar and P type seal, inch size bore ..... 197
<b>RA..-NPP-B</b>	Radial insert ball bearings, spherical outer ring, eccentric locking collar and P type seal, inch size bore ..... 156
<b>RABRA(B)..-XL-FA106</b>	Radial insert ball bearings, with rubber interliner, eccentric locking collar and P type seal ..... 214
<b>RAE..-XL-NPP</b>	Radial insert ball bearings, cylindrical outer ring, eccentric locking collar and P type seal ..... 196
<b>RAE..-XL-NPP-B</b>	Radial insert ball bearings, spherical outer ring, eccentric locking collar and P type seal ..... 154
<b>RAE..-XL-NPP-NR</b>	Radial insert ball bearings, cylindrical outer ring with two slots, eccentric locking collar and P type seal, snap ring ..... 196
<b>RAL..-NPP</b>	Radial insert ball bearings, cylindrical outer ring, eccentric locking collar and P type seal, inch size bore, light series ..... 197
<b>RALE..-XL-NPP</b>	Radial insert ball bearings, cylindrical outer ring, eccentric locking collar and P type seal, light series..... 196
<b>RALE..-XL-NPP-B</b>	Radial insert ball bearings, spherical outer ring, eccentric locking collar and P type seal, light series..... 154
<b>RALT..-XL</b>	Two-bolt flanged housing units, sheet steel housing, eccentric locking collar and P type seal, light series, no relubrication facility ..... 309
<b>RALTR..-XL</b>	Three-bolt flanged housing units, sheet steel housing, eccentric locking collar and P type seal, light series, no relubrication facility ..... 309
<b>RASE..-XL-FA164</b>	Plummer block housing units, cast iron housing, eccentric locking collar and R type seal, for high temperatures, relubrication facility ..... 229
<b>RASE..-XL</b>	Plummer block housing units, cast iron housing, eccentric locking collar and R type seal, relubrication facility..... 229
<b>RASE..-XL-N-FA125</b>	Plummer block housing units, cast iron housing, eccentric locking collar and R type seal, Corrotect, relubrication facility ..... 380

# Product index

	Page
RASEA...-XL	Plummer block housing units, cast iron housing, adapter sleeve and R type seal, relubrication facility ..... 229
RASEL...-XL	Plummer block housing units, cast iron housing, drive slot in inner ring and R type seal, relubrication facility ..... 229
RASEY...-XL	Plummer block housing units, cast iron housing, grub screws in inner ring and R type seal, relubrication facility ..... 229
RASEY...-IT	Plummer block housing units for textile machinery, cast iron housing, grub screws in inner ring and R type seal, relubrication facility ..... 572
RAT...-XL	Two-bolt flanged housing units, sheet steel, eccentric locking collar and P type seal, no relubrication facility ..... 309
RATR...-XL	Three-bolt flanged housing units, sheet steel, eccentric locking collar and P type seal, no relubrication facility ..... 309
RATRY...-XL	Three-bolt flanged housing units, sheet steel, grub screws in inner ring and P type seal, no relubrication facility ..... 309
RATY...-XL	Two-bolt flanged housing units, sheet steel housing, grub screws in inner ring and P type seal, no relubrication facility ..... 309
RAY...-XL	Three-bolt or four-bolt flanged housing units, sheet steel housing, grub screws in inner ring and P type seal, no relubrication facility ..... 309
RCJ...-XL-FA164	Four-bolt flanged housing units, cast iron housing, eccentric locking collar and R type seal, for high temperatures, relubrication facility ..... 231
RCJ...-IA03	Four-bolt flanged housing units for rolls, no relubrication facility ..... 554
RCJ...-XL	Four-bolt flanged housing units, cast iron housing, eccentric locking collar and R type seal, relubrication facility ..... 231
RCJ...-XL-N-FA125	Four-bolt flanged housing units, cast iron housing, eccentric locking collar and R type seal, Corrotect, relubrication facility ..... 380



	Page
<b>RCJL..-XL</b>	Four-bolt flanged housing units, cast iron housing, drive slot in inner ring and R type seal, relubrication facility..... 231
<b>RCJO..-XL</b>	Four-bolt flanged housing units, cast iron housing, eccentric locking collar and R type seal, heavy series, relubrication facility..... 231
<b>RCJT..-XL-FA164</b>	Two-bolt flanged housing units, cast iron housing, eccentric locking collar and R type seal, for high temperatures, relubrication facility ..... 230
<b>RCJT..-IA03</b>	Two-bolt flanged housing units for rolls, no relubrication facility ..... 554
<b>RCJT..-XL</b>	Two-bolt flanged housing units, cast iron housing, eccentric locking collar and R type seal, relubrication facility..... 230
<b>RCJT..-XL-N-FA125</b>	Two-bolt flanged housing units, cast iron housing, eccentric locking collar and R type seal, Corroprotect, relubrication facility ..... 380
<b>RCJTA..-XL</b>	Two-bolt flanged housing units, cast iron housing, adapter sleeve and R type seal, relubrication facility..... 230
<b>RCJTY..-XL</b>	Two-bolt flanged housing units, cast iron housing, grub screws in inner ring and R type seal, relubrication facility..... 230
<b>RCJTZ..-XL</b>	Two-bolt flanged housing units, cast iron housing, with centring spigot, eccentric locking collar and R type seal, relubrication facility..... 230
<b>RCJY..-XL</b>	Four-bolt flanged housing units, cast iron housing, grub screws in inner ring and R type seal, relubrication facility..... 231
<b>RCRA(B)..-XL-FA106</b>	Radial insert ball bearings, with rubber interliner, eccentric locking collar and P type seal, no relubrication facility ..... 214
<b>RCSKY..-VA</b>	Four-bolt flanged housing units, plastic housing, grub screws in inner ring and RSR type seal, bearing rings and rolling bearing made from high grade steel, relubrication facility..... 578
<b>RCSMA(B)..-XL-FA106</b>	Radial insert ball bearings with rubber interliner, eccentric locking collar ..... 214
<b>RCSMF..-XL</b>	Two-bolt flanged housing units, sheet steel housing, with rubber interliner, eccentric locking collar and P type seal, no relubrication facility ..... 309

# Product index

	Page
<b>RCSTKY..VA</b>	Two-bolt flanged housing units, plastic housing, grub screws in inner ring and RSR type seal, bearing rings and rolling bearing made from high grade steel, relubrication facility ..... 578
<b>RFE..-XL</b>	Four-bolt flanged housing units, cast iron housing, with narrow centring spigot, eccentric locking collar and R type seal, relubrication facility ..... 231
<b>RHE..-XL</b>	Take-up housing units, cast iron housing, eccentric locking collar and R type seal, relubrication facility ..... 232
<b>RME..-IA04</b>	Flanged housing units for harvesters, relubrication facility ..... 555
<b>RME..-XL</b>	Four-bolt flanged housing units, cast iron housing, with wide centring spigot, eccentric locking collar and R type seal, relubrication facility ..... 231
<b>RMEO..-XL</b>	Four-bolt flanged housing units, cast iron housing, with wide centring spigot, eccentric locking collar and R type seal, heavy series, relubrication facility ..... 231
<b>RMEO..-IA04</b>	Flanged housing units for harvesters, relubrication facility ..... 555
<b>RMEY..-IA04</b>	Flanged housing units for harvesters, no relubrication facility ..... 555
<b>RMEY..-XL</b>	Four-bolt flanged housing units, cast iron housing, with wide centring spigot, grub screws in inner ring and R type seal, relubrication facility ..... 231
<b>RPB..-XL</b>	Plummer block housing units, sheet steel housing, with rubber interliner, eccentric locking collar and P type seal, no relubrication facility ..... 308
<b>RRTR..-XL</b>	Three-bolt flanged housing units, sheet steel housing, eccentric locking collar and R type seal, no relubrication facility ..... 309
<b>RRY..-VA</b>	Three-bolt or four-bolt flanged housing units, corrosion-resistant sheet steel housing, corrosion-resistant bearing, grub screws in inner ring and R type seal, no relubrication facility ..... 380
<b>RSAO..-XL</b>	Plummer block housing units, cast iron housing, eccentric locking collar and R type seal, heavy series, relubrication facility ..... 229

	Page
<b>RSHE..-XL</b>	Plummer block housing units, cast iron housing, eccentric locking collar and R type seal, relubrication facility..... 229
<b>RSHEY..-XL</b>	Plummer block housing units, cast iron housing, grub screws in inner ring and R type seal, relubrication facility..... 229
<b>RTUE..-XL</b>	Take-up housing units, cast iron housing, eccentric locking collar and R type seal, relubrication facility..... 232
<b>RTUEO..-XL</b>	Take-up housing units, cast iron housing, eccentric locking collar and R type seal, heavy series, relubrication facility..... 232
<b>RTUEY..-XL</b>	Take-up housing units, cast iron housing, grub screws in inner ring and R type seal, relubrication facility..... 232
<b>SH</b>	Radial insert ball bearings for textile machinery, spherical outer ring, adapter sleeve and BRS type seal, Corrotect, no relubrication facility ..... 572
<b>SK..-KRR</b>	Self-aligning deep groove ball bearings, cylindrical outer ring, hexagonal bore and R type seal..... 197
<b>SK..-KRR-B</b>	Self-aligning deep groove ball bearings, spherical outer ring, hexagonal bore and R type seal ..... 156
<b>SK..-KTT</b>	Self-aligning deep groove ball bearings, cylindrical outer ring, hexagonal bore and T type seal ..... 197
<b>SUB</b>	Radial insert ball bearings, spherical outer ring, grub screws in narrow inner ring and RSR type seal, corrosion-resistant VA design ..... 356
<b>SUBPCTL</b>	Two-bolt flanged housing units, plastic housing, grub screws in narrow inner ring and RSR type seal, corrosion-resistant VA design, relubrication facility ..... 430
<b>SUBPF</b>	Four-bolt flanged housing units, plastic housing, grub screws in narrow inner ring and RSR type seal, corrosion-resistant VA design, relubrication facility ..... 430
<b>SUBPFL</b>	Two-bolt flanged housing units, plastic housing, grub screws in narrow inner ring and RSR type seal, corrosion-resistant VA design, relubrication facility ..... 430

# Product index

	Page
<b>SUBPHE</b>	Take-up housing units, plastic housing, grub screws in narrow inner ring and RSR type seal, corrosion-resistant VA design, relubrication facility ..... 430
<b>SUBPP</b>	Plummer block housing units with long base, plastic housing, grub screws in narrow inner ring and RSR type seal, corrosion-resistant VA design, relubrication facility ..... 430
<b>SUBPPA</b>	Plummer block housing units with short base, plastic housing, grub screws in narrow inner ring and RSR type seal, corrosion-resistant VA design, relubrication facility ..... 430
<b>SUBPT</b>	Take-up housing units with guidance slot, plastic housing, grub screws in narrow inner ring and RSR type seal, corrosion-resistant VA design, relubrication facility ..... 430
<b>SUC</b>	Radial insert ball bearings, spherical outer ring, grub screws in narrow inner ring and RSR type seal, flinger shields, corrosion-resistant VA design ..... 356
<b>SUCPF</b>	Four-bolt flanged housing units, plastic housing, grub screws in wide inner ring and RSR type seal, corrosion-resistant VA design, relubrication facility ..... 430
<b>SUCPFL</b>	Two-bolt flanged housing units, plastic housing, grub screws in wide inner ring and RSR type seal, corrosion-resistant VA design, relubrication facility ..... 430
<b>SUCPHE</b>	Take-up housing units, plastic housing, grub screws in narrow inner ring and RSR type seal, corrosion-resistant VA design, relubrication facility ..... 430
<b>SUCPP</b>	Plummer block housing units with long base, plastic housing, grub screws in wide inner ring and RSR type seal, corrosion-resistant VA design, relubrication facility ..... 430
<b>SUCPPA</b>	Plummer block housing units with short base, plastic housing, grub screws in wide inner ring and RSR type seal, corrosion-resistant VA design, relubrication facility ..... 430
<b>SUCPT</b>	Take-up housing units with guidance slot, plastic housing, grub screws in wide inner ring and RSR type seal, corrosion-resistant VA design, relubrication facility ..... 430
<b>SUCSF</b>	Four-bolt flanged housing units, corrosion-resistant housing, grub screws in wide inner ring and RSR type seal, corrosion-resistant VA design, relubrication facility ..... 400
<b>SUCSFL</b>	Two-bolt flanged housing units, corrosion-resistant housing, grub screws in wide inner ring and RSR type seal, corrosion-resistant VA design, relubrication facility ..... 400

	Page
<b>SUCSP</b>	Plummer block housing units with long base, corrosion-resistant housing, grub screws in wide inner ring and RSR type seal, corrosion-resistant VA design, relubrication facility ..... 400
<b>SUCSPA</b>	Plummer block housing units with short base, corrosion-resistant housing, grub screws in wide inner ring and RSR type seal, corrosion-resistant VA design, relubrication facility ..... 400
<b>SUCST</b>	Take-up housing units with guide slot, corrosion-resistant housing, eccentric locking collar and RSR type seal, corrosion-resistant VA design, relubrication facility ..... 401
<b>SUG</b>	Radial insert ball bearings, spherical outer ring, eccentric locking collar and RSR type seal, corrosion-resistant VA design ..... 356
<b>SUGPCTL</b>	Two-bolt flanged housing units, plastic housing, eccentric locking collar and RSR type seal, corrosion-resistant VA design, relubrication facility ..... 430
<b>SUGPF</b>	Four-bolt flanged housing units, plastic housing, eccentric locking collar and RSR type seal, corrosion-resistant VA design, relubrication facility ..... 430
<b>SUGPFL</b>	Two-bolt flanged housing units, plastic housing, eccentric locking collar and RSR type seal, corrosion-resistant VA design, relubrication facility ..... 430
<b>SUGPHE</b>	Take-up housing units, plastic housing, eccentric locking collar and RSR type seal, corrosion-resistant VA design, relubrication facility ..... 430
<b>SUGPP</b>	Plummer block housing units with long base, plastic housing, eccentric locking collar and RSR type seal, corrosion-resistant VA design, relubrication facility ..... 430
<b>SUGPPA</b>	Plummer block housing units with short base, plastic housing, eccentric locking collar and RSR type seal, corrosion-resistant VA design, relubrication facility ..... 430
<b>SUGPT</b>	Take-up housing units with guide slot, plastic housing, eccentric locking collar and RSR type seal, corrosion-resistant VA design, relubrication facility ..... 430
<b>TASE..-XL</b>	Plummer block housing units, cast iron housing, eccentric locking collar and T type seal, relubrication facility..... 229
<b>TCJ..-XL</b>	Four-bolt flanged housing units, cast iron housing, eccentric locking collar and T type seal, relubrication facility..... 231

# Product index

	Page
TCJY.-IA03	Four-bolt flanged housing units for rolls, no relubrication facility ..... 554
TCJT.-XL	Two-bolt flanged housing units, cast iron housing, eccentric locking collar and T type seal, relubrication facility ..... 230
TFE.-XL	Four-bolt flanged housing units, cast iron housing, with narrow centring spigot, eccentric locking collar and T type seal, relubrication facility ..... 231
THE.-XL	Take-up housing units, cast iron housing, eccentric locking collar and T type seal, relubrication facility ..... 232
TME.-IA04	Flanged housing units for harvesters, no relubrication facility ..... 555
TME.-XL	Four-bolt flanged housing units, cast iron housing, with wide centring spigot, eccentric locking collar and T type seal, relubrication facility ..... 231
TRV.-IA02	Flanged housing units for plough discs, sheet steel housing, square bore and T type seal, no relubrication facility ..... 554
TSHE.-XL	Plummer block housing units, cast iron housing, eccentric locking collar and T type seal, relubrication facility ..... 229
TSHEV.-IA04	Flanged housing units for harvesters, relubrication facility ..... 555
TTUE.-XL	Take-up housing units, cast iron housing, eccentric locking collar and T type seal, relubrication facility ..... 232
UC	Radial insert ball bearings, spherical outer ring, with grub screws in inner ring, Durotect BS coating, relubrication facility ..... 474
UCF	Four-bolt flanged housing units, cast iron housing, square version, with grub screws in inner ring, Durotect BS coating, relubrication facility ..... 493
UCFA	Take-up housing units, cast iron housing for swivel motion, with grub screws in inner ring, Durotect BS coating, relubrication facility ..... 493

	Page
<b>UCFC</b>	Four-bolt flanged housing units, cast iron housing, round version, with grub screws in inner ring, Durotect BS coating, relubrication facility..... 493
<b>UCFL</b>	Two-bolt flanged housing units, cast iron housing, oval version, with grub screws in inner ring, Durotect BS coating, relubrication facility..... 492
<b>UCP</b>	Plummer block housing units, cast iron housing with long base, with grub screws in inner ring, Durotect BS coating, relubrication facility..... 492
<b>UCPA</b>	Plummer block housing units, cast iron housing with short base, with grub screws in inner ring, Durotect BS coating, relubrication facility..... 492
<b>UCT</b>	Take-up housing units, cast iron housing for linear motion, with grub screws in inner ring, Durotect BS coating, relubrication facility..... 493
<b>UK</b>	Radial insert ball bearings, spherical outer ring, with adapter sleeve, Durotect BS coating, relubrication facility..... 474
<b>UKF</b>	Four-bolt flanged housing units, cast iron housing, square version, with radial insert ball bearing, Durotect BS coating, relubrication facility..... 493
<b>UKFC</b>	Four-bolt flanged housing units, cast iron housing, round version, with radial insert ball bearing, Durotect BS coating, relubrication facility..... 493
<b>UKFL</b>	Two-bolt flanged housing units, cast iron housing, oval version, with radial insert ball bearing, Durotect BS coating, relubrication facility..... 492
<b>UKP</b>	Plummer block housing units, cast iron housing with long base, with radial insert ball bearing, Durotect BS coating, relubrication facility..... 492
<b>UKT</b>	Take-up housing units, cast iron housing for linear motion, with radial insert ball bearing, Durotect BS coating, relubrication facility..... 493
<b>VK..-KTT-B</b>	Self-aligning deep groove ball bearings, spherical outer ring, square bore and T type seal ..... 156

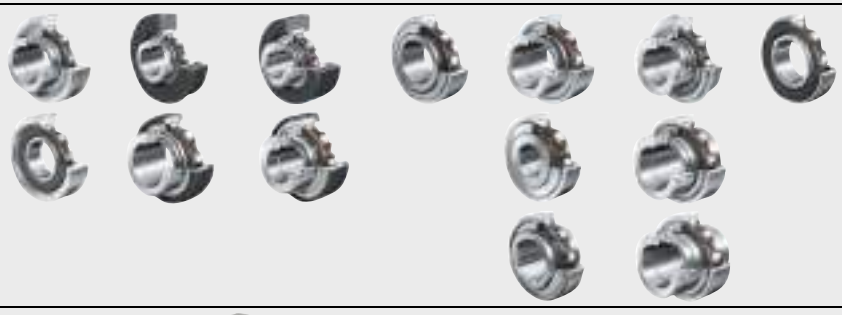

0008C08E



0008C04A



0008C08C



0008C0D1



0008C0E6



0008C0F8



0008C10A





00015CE8

## Technical principles



0008C092

### Radial insert ball bearings

- Spherical outer ring
- Cylindrical outer ring
- Rubber interliner
- Steel aligning ring



0008COAE

### INA units with flake graphite cast iron or sheet steel housing

- Plummer block housing units
- Flanged housing units
- Take-up housing units



0008C0C0

### Roller chain idler sprocket units Idler pulley units



0008C0D5

### Corrosion-resistant radial insert ball bearings and housing units

- Flake graphite cast iron and sheet steel housings
- High grade steel housings
- Plastic housings



0008COEA

### FAG Black Series Radial insert ball bearings and housing units



0008C0FC

### Market sectors



0008C10E

### Mounting and maintenance



00018048

### Addresses



**FAG**

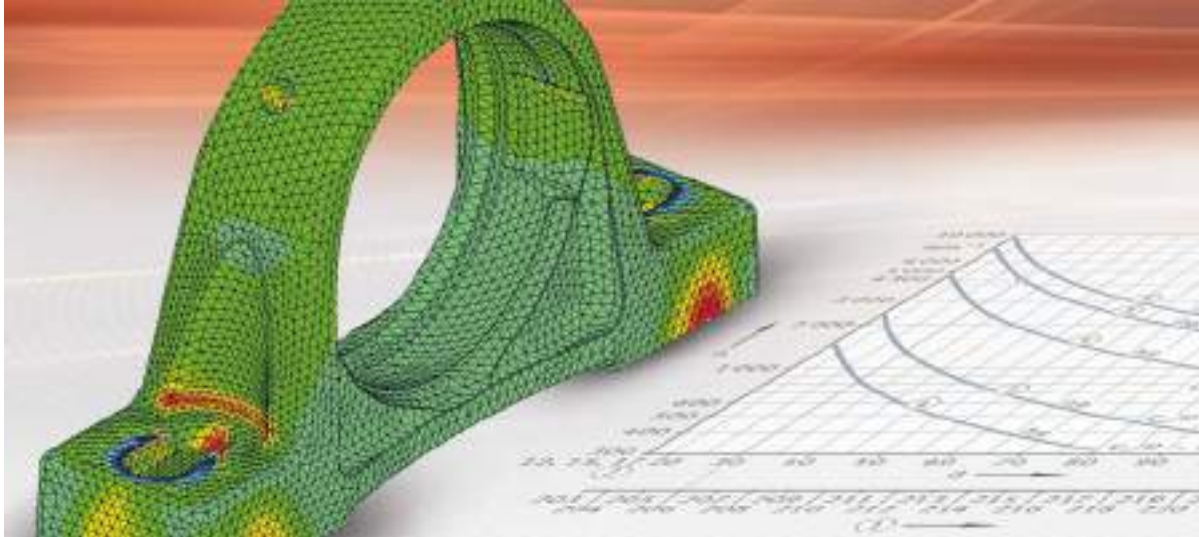

## Technical principles

- Load carrying capacity and life
- Friction and increases in temperature
- Speeds
- Lubrication
- Bearing data
- Design of bearing arrangements
- Sealing
- Mounting and dismounting



# Technical principles

	Page	
<b>Load carrying capacity and life</b>	Fatigue theory as a principle .....	36
	Dimensioning of rolling bearings.....	37
	Dynamic load carrying capacity and life.....	37
	Calculation of the rating life .....	38
	Basic rating life .....	38
	Adjusted rating life.....	42
	Expanded adjusted rating life.....	45
	Equivalent operating values.....	49
	Variable load and speed .....	49
	Requisite rating life .....	51
	Operating life .....	52
	Static load carrying capacity .....	53
	Static load safety factor.....	53
	<b>Friction and increases in temperature</b>	Friction.....
Heat dissipation .....		54
Calculation of friction values .....		55
<b>Speeds</b>	Criteria for speed limitation .....	57
	Limiting speed.....	57
	Thermal reference speed .....	57
	Reference conditions .....	58
	Thermally safe operating speed .....	58
	Limits of calculation method .....	59
Calculation of thermally safe operating speed .....	59	
<b>Lubrication</b>	Principles .....	62
	Functions of the lubricant.....	62
	Design of lubrication system .....	62
	Grease lubrication .....	63
	Composition of a grease.....	63
	Type of grease.....	64
	Consistency of greases.....	64
	Selection of suitable grease .....	65
	Greases with special suitability .....	68
	Grease operating life .....	70
	Relubrication intervals .....	76
	Miscibility.....	78
	Storage.....	78

# Technical principles

	Page
<b>Bearing data</b>	
Radial internal clearance.....	79
Operating clearance.....	80
Operating clearance value .....	80
Calculation of operating clearance.....	80
Axial internal clearance.....	82
Calculation example.....	83
Bearing materials.....	84
Corrosion-resistant steels.....	84
Cages .....	85
Sheet metal cages.....	85
Solid cages made from polyamide PA66 .....	86
Operating temperature.....	87
Sealed bearings .....	87
Anti-corrosion protection .....	88
Anti-corrosion coating system Corrotect.....	88
Dimensional and running tolerances .....	89
Radial bearings .....	96
Chamfer dimensions .....	99
<b>Design of bearing arrangements</b>	
Conditions of rotation .....	100
Point load .....	100
Circumferential load .....	100
Shaft and housing tolerances.....	101
Tolerance classes.....	101
Reference to tables of shaft and housing tolerances.....	101
Tables of shaft and housing fits .....	103
Geometrical and positional tolerances of bearing seating surfaces .....	116
Accuracy of bearing seating surfaces .....	117
<b>Sealing</b>	
Functions.....	119
Overview of seal types .....	119
BRS seals.....	121
Non-contact seals in the adjacent construction .....	121



	Page
<b>Mounting and dismounting</b>	
Handling and use .....	122
Storage of rolling bearings .....	122
Storage of Arcanol rolling bearing greases .....	124
Unpacking of rolling bearings.....	124
Compatibility, miscibility.....	124
Cleaning of rolling bearings.....	125
General guidelines for mounting .....	126
Mounting of housing units .....	127
Delivered condition, INA brand .....	127
Delivered condition, FAG brand.....	127
Storage and shelf life.....	127
Unpacking.....	127
Guidelines for mounting of housing units.....	128
Mounting of coated components.....	128
Mounting of cast units .....	129
Radial insert ball bearings with eccentric locking collar or grub screw in inner ring .....	129
Radial insert ball bearings with adapter sleeve .....	131
Fitting of bearing end caps .....	134
Mounting of sheet steel units.....	136
Mounting of rolling bearings with cylindrical seats .....	138
Non-separable bearings .....	138
Cold fitting of bearings by pressing.....	138
Heating of bearings.....	139
Guidelines for dismounting.....	140
Dismounting of rolling bearings on cylindrical seats .....	141
Removal of small bearings .....	141

# Load carrying capacity and life

Schaeffler introduced the “Expanded calculation of the adjusted rating life” in 1997. This method was standardised for the first time in DIN ISO 281 Appendix 1 and has been a constituent part of the international standard ISO 281 since 2007.

As part of the international standardisation work, the life adjustment factor  $a_{DIN}$  was renamed as  $a_{ISO}$  but without any change to the calculation method.

## Fatigue theory as a principle

The basis of the rating life calculation in accordance with ISO 281 is Lundberg and Palmgren's fatigue theory which always gives a final rating life.

However, modern, high quality bearings can exceed by a considerable margin the values calculated for the basic rating life under favourable operating conditions. Ioannides and Harris have developed a further model of fatigue in rolling contact that expands on the Lundberg/Palmgren theory and gives a better description of the performance capability of modern bearings.

The method “Expanded calculation of the adjusted rating life” takes account of the following influences:

- the bearing load
- the fatigue limit of the material
- the extent to which the surfaces are separated by the lubricant
- the cleanliness in the lubrication gap
- the additive package in the lubricant
- the internal load distribution and frictional conditions in the bearing.



The influencing factors, particularly those relating to contamination, are very complex. A great deal of experience is required in order to arrive at an accurate assessment. Further advice should therefore be sought from the Schaeffler engineering service.

The tables and diagrams can give guide values only.



## **Dimensioning of rolling bearings**

The required size of a rolling bearing is dependent on the demands made on its:

- rating life
- load carrying capacity
- operational reliability.

## **Dynamic load carrying capacity and life**

The dynamic load carrying capacity is described in terms of the basic dynamic load ratings. The basic dynamic load ratings are based on DIN ISO 281.

The basic dynamic load ratings for rolling bearings are matched to empirically proven performance standards and published in previous FAG and INA catalogues.

The dynamic load carrying capacity of the rolling bearing is determined by the fatigue behaviour of the material.

The dynamic load carrying capacity is described in terms of the basic dynamic load rating and the basic rating life.

The fatigue life is dependent on:

- the load
- the operating speed
- the statistical probability of the first appearance of failure.

In the case of rotating rolling bearings, the basic dynamic load rating  $C$  is:

- a constant radial load  $C_r$  for radial bearings
- a constant, concentrically acting axial load  $C_a$  for axial bearings.

The basic dynamic load rating  $C$  is that load of constant magnitude and direction which a sufficiently large number of apparently identical bearings can endure for a basic rating life of one million revolutions.

# Load carrying capacity and life

## Calculation of the rating life

The methods for calculating the rating life are:

- the basic rating life  $L_{10}$  and  $L_{10h}$  in accordance with ISO 281, see page 38
- the adjusted rating life  $L_{na}$  in accordance with DIN ISO 281:1990 (no longer a constituent part of ISO 281), see page 42
- the expanded adjusted rating life  $L_{nm}$  in accordance with ISO 281, see page 45.

## Basic rating life

The basic rating life  $L_{10}$  and  $L_{10h}$  is determined as follows:

$$L_{10} = \left( \frac{C}{P} \right)^p$$

$$L_{10h} = \frac{16\,666}{n} \cdot \left( \frac{C}{P} \right)^p$$

$L_{10}$   $10^6$  revolutions

The basic rating life in millions of revolutions is the life reached or exceeded by 90% of a sufficiently large group of apparently identical bearings before the first evidence of material fatigue develops

C N  
Basic dynamic load rating

P N

Equivalent dynamic bearing load for radial and axial bearings

p -

Life exponent;

for roller bearings:  $p = 10/3$ , for ball bearings:  $p = 3$

$L_{10h}$  h

The basic rating life in operating hours according to the definition for  $L_{10}$

n  $\text{min}^{-1}$

Operating speed.





**Equivalent dynamic bearing load**

The equivalent dynamic load P is a calculated value. This value is constant in magnitude and direction; it is a radial load for radial bearings and an axial load for axial bearings.

A load corresponding to P will give the same rating life as the combined load occurring in practice.

For bearings under dynamic loading, the following applies:

**Load ratio and axial bearing load**

Load ratio	Equivalent dynamic bearing load
$\frac{F_a}{F_r} \leq e$	$P = F_r$
$\frac{F_a}{F_r} > e$	$P = X \cdot F_r + Y \cdot F_a$

$F_a$  N  
Axial dynamic bearing load  
 $F_r$  N  
Radial dynamic bearing load  
e, X, Y –  
Factors, see table Factors e, X and Y  
P N  
Equivalent dynamic bearing load for combined load.

**Factors e, X and Y**

$\frac{f_0 \cdot F_a}{C_{Or}}$	Factor for radial internal clearance								
	Group N			Group 3			Group 4		
	e	X	Y	e	X	Y	e	X	Y
0,3	0,22	0,56	2	0,32	0,46	1,7	0,4	0,44	1,4
0,5	0,24	0,56	1,8	0,35	0,46	1,56	0,43	0,44	1,31
0,9	0,28	0,56	1,58	0,39	0,46	1,41	0,45	0,44	1,23
1,6	0,32	0,56	1,4	0,43	0,46	1,27	0,48	0,44	1,16
3	0,36	0,56	1,2	0,48	0,46	1,14	0,52	0,44	1,08
6	0,43	0,56	1	0,54	0,46	1	0,56	0,44	1

$f_0$  –  
Factor, see table Factor  $f_0$ , page 40  
 $F_a$  N  
Axial dynamic bearing load  
 $C_{Or}$  N  
Basic static load rating, see dimension tables.

## Load carrying capacity and life

The values in the following table are valid for normal fits:

■ shaft machined to j5 © or k5 ©, housing machined to J6 ©.

Factor  $f_0$

Bore code	Factor $f_0$		
	60	62	63
3	–	12,9	–
4	–	12,2	12,4
5	–	13,2	12,2
6	–	13	–
7	13	12,4	–
8	12,4	13	–
9	13	12,4	–
00	12,4	12,1	11,3
01	13	12,3	11,1
02	13,9	13,1	12,1
03	14,3	13,1	12,3
04	13,9	13,1	12,4
05	14,5	13,8	12,4
06	14,8	13,8	13
07	14,8	13,8	13,1
08	15,3	14	13
09	15,4	14,3	13
10	15,6	14,3	13
11	15,4	14,3	12,9
12	15,5	14,3	13,1
13	15,7	14,3	13,2
14	15,5	14,4	13,2
15	15,7	14,7	13,2
16	15,6	14,6	13,2
17	15,7	14,7	13,1
18	15,6	14,5	13,9
19	15,7	14,4	13,9
20	15,9	14,4	13,8
21	15,8	14,3	13,8
22	15,6	14,3	13,8
24	15,9	14,8	13,5
26	15,8	14,5	13,6
28	16	14,8	13,6
30	16	15,2	13,7
32	16	15,2	13,9
34	15,7	15,3	13,9
36	15,6	15,3	13,9
38	15,8	15	14
40	15,6	15,3	14,1
44	15,6	15,2	14,1
48	15,8	15,2	14,2



**Factor  $f_0$**   
(continued)

Bore code	Factor $f_0$		
	60	62	63
52	15,7	15,2	–
56	15,9	15,3	–
60	15,7	–	–
64	15,9	–	–
68	15,8	–	–
72	15,9	–	–
76	–	–	–
80	–	–	–
84	–	–	–
88	–	–	–
92	–	–	–
96	–	–	–

**Equivalent static load**

The equivalent static load  $P_0$  is a calculated value. It corresponds to a radial load in radial bearings and a concentric axial load in axial bearings.

$P_0$  induces the same load at the centre point of the most heavily loaded contact point between the rolling element and raceway as the combined load occurring in practice.

$$P_0 = X_0 \cdot F_{0r} + Y_0 \cdot F_{0a}$$

$P_0$                                     N  
Equivalent static bearing load

$X_0$                                     –  
Radial factor

$F_{0r}$                                     N  
Radial static bearing load

$Y_0$                                     –  
Axial factor

$F_{0a}$                                     N  
Axial static bearing load.

**Load ratio and axial bearing load**

For bearings under static loading, the following applies:

Load ratio	Equivalent static load
$\frac{F_{0a}}{F_{0r}} \leq 0,8$	$P_0 = F_{0r}$
$\frac{F_{0a}}{F_{0r}} > 0,8$	$P_0 = 0,6 \cdot F_{0r} + 0,5 \cdot F_{0a}$

$F_{0a}$                                     N  
Axial static bearing load

$F_{0r}$                                     N  
Radial static bearing load

$P_0$                                     N  
Equivalent static bearing load for combined load.

# Load carrying capacity and life

## Adjusted rating life

The adjusted rating life  $L_{na}$  can be calculated if, in addition to the load and speed, other influences are known:

- special material characteristics
- lubrication
- a requisite reliability other than 90%.

This calculation method was replaced in ISO 281:2007 by the calculation of the expanded adjusted rating life  $L_{nm}$ , see page 45.

$$L_{na} = a_1 \cdot a_2 \cdot a_3 \cdot L_{10}$$

$L_{na}$  10<sup>6</sup> revolutions

Adjusted rating life for special material characteristics and operating conditions with a requisite reliability of (100 - n) %

$a_1$  -

Life adjustment factor for a requisite reliability other than 90%.

In ISO 281:2007, the values for the life adjustment factor  $a_1$  have been redefined, see table Life adjustment factor  $a_1$ , page 45

$a_2$  -

Life adjustment factor for special material characteristics.

For standard rolling bearing steels:  $a_2 = 1$

$a_3$  -

Life adjustment factor for special operating conditions; in particular for the lubrication regime, *Figure 1*

$L_{10}$  10<sup>6</sup> revolutions

Basic rating life.

$a_3$  = life adjustment factor  
 $\kappa$  = viscosity ratio, see page 43

- ① Good cleanliness and suitable additives
- ② Very high cleanliness and low load
- ③ Contamination in the lubricant

*Figure 1*

Life adjustment factor  $a_3$

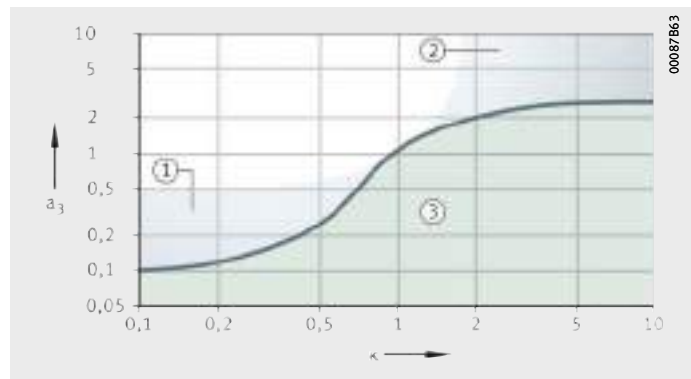



**Viscosity ratio** The viscosity ratio  $\kappa$  is an indication of the quality of lubricant film formation.

The reference viscosity  $\nu_1$  is determined from the mean bearing diameter  $d_M = (D + d)/2$  and the operating speed  $n$ , *Figure 2*, page 44.

The nominal viscosity of the oil at +40 °C is determined from the required operating viscosity  $\nu$  and the operating temperature  $\vartheta$ , *Figure 3*, page 44. In the case of greases,  $\nu$  is the operating viscosity of the base oil.

In accordance with ISO 281, the equations can also be used in approximate terms for synthetic oils, such as those of the type synthetic hydrocarbons (SHC).

In the case of heavily loaded bearings with a high proportion of sliding contact, the temperature in the contact area of the rolling elements may be up to 20 K higher than the temperature measured on the stationary ring (without the influence of any external heat sources).



The influence of EP additives is taken into consideration in calculation of the expanded adjusted rating life  $L_{nm}$ , see page 47.

**Viscosity ratio  $\kappa$**

$$\kappa = \frac{\nu}{\nu_1}$$

**Reference viscosity  $\nu_1$**

$\nu < 1000 \text{ min}^{-1}$ :

$$\nu_1 = 4500 \cdot n^{-0,83} \cdot d_M^{-0,5}$$

$\nu > 1000 \text{ min}^{-1}$ :

$$\nu_1 = 4500 \cdot n^{-0,5} \cdot d_M^{-0,5}$$

$\kappa$	–
Viscosity ratio	
$\nu$	$\text{mm}^2\text{s}^{-1}$
Kinematic viscosity of the lubricant at operating temperature	
$\nu_1$	$\text{mm}^2\text{s}^{-1}$
Reference viscosity of the lubricant at operating temperature	
$n$	$\text{min}^{-1}$
Reference speed.	

# Load carrying capacity and life

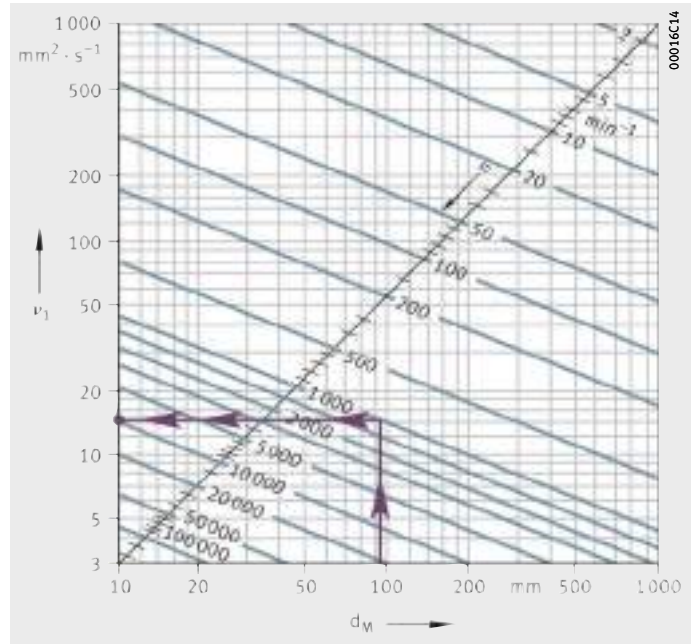

$v_1$  = reference viscosity  
 $d_M$  = mean bearing diameter  
 $n$  = speed

**Figure 2**  
 Reference viscosity  $v_1$

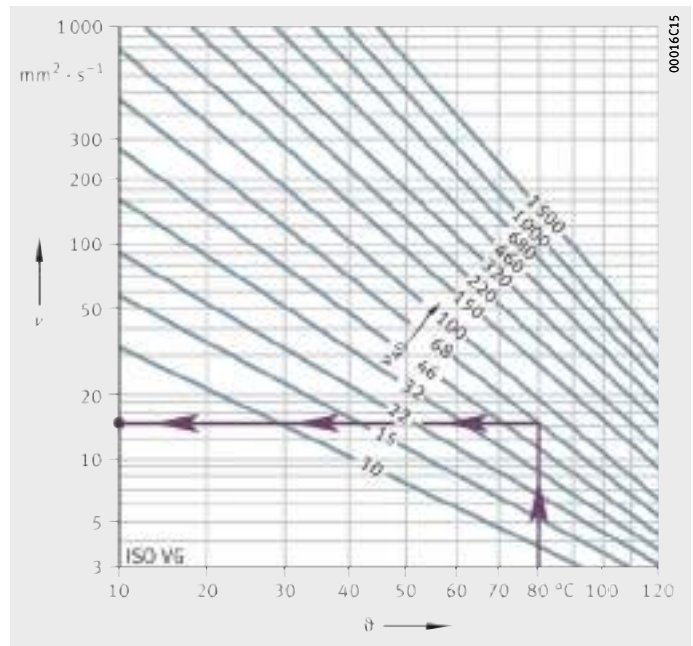

$v$  = operating viscosity  
 $\vartheta$  = operating temperature  
 $v_{40}$  = viscosity at +40 °C

**Figure 3**  
 V/T diagram for mineral oils



## Expanded adjusted rating life

The calculation of the expanded adjusted rating life  $L_{nm}$  is standardised in the worldwide standard ISO 281. Computer-aided calculation in accordance with DIN ISO 281 Appendix 4 has been specified since 2008 in ISO/TS 16281.

$L_{nm}$  is calculated as follows:

$$L_{nm} = a_1 \cdot a_{ISO} \cdot L_{10}$$

$L_{nm}$  Expanded adjusted rating life to ISO 281

$a_1$  Life adjustment factor for a requisite reliability other than 90%, see table

$a_{ISO}$  Life adjustment factor for operating conditions

$L_{10}$  Basic rating life, see page 38.

The values for the life adjustment factor  $a_1$  were redefined in ISO 281:2007 and differ from the previous data.

### Life adjustment factor $a_1$

Requisite reliability %	Expanded adjusted rating life $L_{nm}$	Life adjustment factor $a_1$
90	$L_{10m}$	1
95	$L_{5m}$	0,64
96	$L_{4m}$	0,55
97	$L_{3m}$	0,47
98	$L_{2m}$	0,37
99	$L_{1m}$	0,25
99,2	$L_{0,8m}$	0,22
99,4	$L_{0,6m}$	0,19
99,6	$L_{0,4m}$	0,16
99,8	$L_{0,2m}$	0,12
99,9	$L_{0,1m}$	0,093
99,92	$L_{0,08m}$	0,087
99,94	$L_{0,06m}$	0,08
99,95	$L_{0,05m}$	0,077

# Load carrying capacity and life

## Life adjustment factor $a_{ISO}$

The standardised method for calculating the life adjustment factor  $a_{ISO}$  takes account of the following significant factors:

- the load on the bearing
- the lubrication conditions (viscosity and type of lubricant, speed, bearing size, additives)
- the fatigue limit of the material
- the type of bearing
- the fatigue limit of the material
- the ambient conditions
- contamination of the lubricant.

$$a_{ISO} = f \left[ \frac{e_c \cdot C_u}{P}, \kappa \right]$$

$a_{ISO}$	–
Life adjustment factor for operating conditions, <i>Figure 4</i> , page 47	
$e_c$	–
Life adjustment factor for contamination, see table, page 48	
$C_u$	N
Fatigue limit load	
$P$	N
Equivalent dynamic bearing load	
$\kappa$	–
Viscosity ratio, see page 43	
For $\kappa > 4$ , calculation should be carried out using $\kappa = 4$ .	
For $\kappa < 0,1$ , this calculation method cannot be used.	





### Taking account of EP additives in the lubricant

In accordance with ISO 281, EP additives in the lubricant can be taken into consideration. At a viscosity ratio  $\kappa < 1$  and a contamination factor  $e_c \geq 0,2$ , a value  $\kappa = 1$  can be used in calculation in the case of lubricants with EP additives that have proven effective. If severe contamination is present (contamination factor  $e_c < 0,2$ ), the effectiveness of the additives under these contamination conditions must be proven.

The effectiveness of the EP additives can be demonstrated in the actual application or on a rolling bearing test rig FE 8 to DIN 51819-1.

If the EP additives are proven effective and calculation is carried out using the value  $\kappa = 1$ , the life adjustment factor must be restricted to  $a_{ISO} \leq 3$ , *Figure 4*. If the calculated value  $a_{ISO}$  calculated for the actual  $\kappa$  is  $> 3$ , this value can be used in calculation.

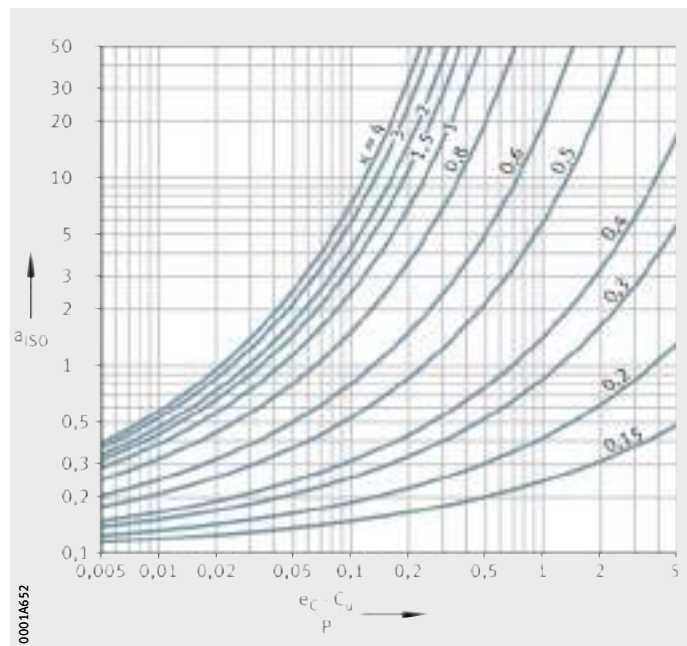

*Figure 4*  
Life adjustment factor  $a_{ISO}$   
for radial ball bearings

# Load carrying capacity and life

## Fatigue limit load

The fatigue limit load  $C_U$  in accordance with ISO 281 is defined as the load below which, under laboratory conditions, no fatigue occurs in the material.

## Life adjustment factor for contamination

The life adjustment factor for contamination  $e_C$  takes into consideration the influence of contamination in the lubrication gap on the rating life, see table.

The rating life is reduced by solid particles in the lubrication gap and is dependent on the following factors:

- the type, size, hardness and quantity of particles
- the relative lubricant film thickness
- the bearing size.

Due to the complex interactions between these influencing factors, it is only possible to give approximate guide values. The values in the tables are valid for contamination by solid particles (factor  $e_C$ ). No account is taken of other contamination such as that caused by water or other fluids.



Under severe contamination ( $e_C \rightarrow 0$ ), the bearings may fail due to wear. In this case, the operating life is substantially less than the calculated life.

## Factor $e_C$

Contamination	Factor $e_C$			
	$d_M < 100 \text{ mm}^1$		$d_M \geq 100 \text{ mm}^1$	
	from	to	from	to
Extreme cleanliness: ■ particle size within lubricant film thickness ■ laboratory conditions	–	1	–	1
High cleanliness: ■ oil filtered through extremely fine filter ■ sealed, greased bearings	0,6	0,8	0,8	0,9
Standard cleanliness: ■ oil filtered through fine filter	0,5	0,6	0,6	0,8
Low contamination: ■ slight contamination of oil	0,3	0,5	0,4	0,6
Typical contamination: ■ bearing contaminated by wear debris from other machine elements	0,1	0,3	0,2	0,4
Heavy contamination: ■ bearing environment heavily contaminated ■ bearing arrangement inadequately sealed	0	0,1	0	0,1
Very heavy contamination	0	–	0	–

<sup>1)</sup>  $d_M$  = mean bearing diameter  $(d + D)/2$ .



## Equivalent operating values

The rating life equations are based on the assumption that the bearing load P and bearing speed n are constant. If the load and speed are not constant, equivalent operating values can be determined that induce the same fatigue as the actual loading conditions.



The equivalent operating values calculated here already take account of the life adjustment factors  $a_3$  or  $a_{ISO}$ . They must not be applied again when calculating the adjusted rating life.

### Variable load and speed

If the load and speed vary over a time period T, the speed n and equivalent bearing load P are calculated as follows:

$$n = \frac{1}{T} \int_0^T n(t) \cdot dt$$

$$P = P \sqrt{\frac{\int_0^T \frac{1}{a(t)} \cdot n(t) \cdot F^P(t) \cdot dt}{\int_0^T n(t) \cdot dt}}$$

### Variation in steps

If the load and speed vary in steps over a time period T, n and P are calculated as follows:

$$n = \frac{q_1 \cdot n_1 + q_2 \cdot n_2 + \dots + q_z \cdot n_z}{100}$$

$$P = P \sqrt{\frac{\frac{1}{a_i} \cdot q_i \cdot n_i \cdot F_i^P + \dots + \frac{1}{a_z} \cdot q_z \cdot n_z \cdot F_z^P}{q_i \cdot n_i + \dots + q_z \cdot n_z}}$$

### Variable load at constant speed

If the function F describes the variation in the load over a time period T and the speed is constant, P is calculated as follows:

$$P = P \sqrt{\frac{1}{T} \int_0^T \frac{1}{a(t)} \cdot F^P(t) \cdot dt}$$

### Load varying in steps at constant speed

If the load varies in steps over a time period T and the speed is constant, P is calculated as follows:

$$P = P \sqrt{\frac{\frac{1}{a_i} \cdot q_i \cdot F_i^P + \dots + \frac{1}{a_z} \cdot q_z \cdot F_z^P}{100}}$$

### Constant load at variable speed

If the speed varies but the load remains constant, the following applies:

$$n = \frac{1}{T} \int_0^T \frac{1}{a(t)} \cdot n(t) \cdot dt$$

# Load carrying capacity and life

## Constant load at speed varying in steps

If the speed varies in steps, the following applies:

$$n = \frac{\frac{1}{a_i} \cdot q_i \cdot n_i + \dots + \frac{1}{a_z} \cdot q_z \cdot n_z}{100}$$

## Oscillating bearing motion

The equivalent speed is calculated as follows:

$$n = n_{osc} \cdot \frac{\varphi}{180^\circ}$$



If the angle of oscillation is smaller than twice the pitch angle of the rolling elements, there is a risk of false brinelling.

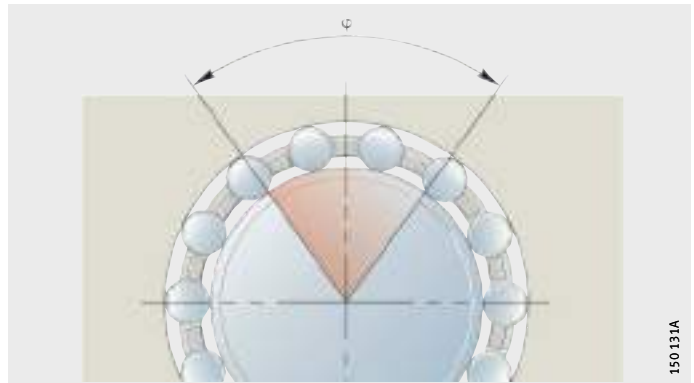

Figure 5  
Angle of oscillation  $\varphi$

## Symbols, units and definitions

$n$	$\text{min}^{-1}$
Mean speed	
$T$	$\text{min}$
Time period under consideration	
$n_i, n(t)$	$\text{min}^{-1}$
Bearing speed for a particular operating condition	
$P$	$N$
Equivalent bearing load	
$p$	-
Life exponent;	
for roller bearings: $p = 10/3$	
for ball bearings: $p = 3$	
$a_i, a(t)$	-
Life adjustment factor $a_{i50}$ for current operating condition, see page 46	
$F_i, F(t)$	$N$
Bearing load for a particular operating condition	
$q_i$	%
Duration of operating condition as a proportion of the total operating period;	
$q_i = (\Delta t_i / T) \cdot 100$	
$n_{osc}$	$\text{min}^{-1}$
Frequency of oscillating motion	
$\varphi$	$^\circ$
Angle of oscillation, Figure 5.	



## Requisite rating life

If no information is available on the rating life, the guide values from the tables may be used.



Do not overspecify the bearings, otherwise it may not be possible to observe the minimum load, see the design and safety guidelines in the product sections.

### Agricultural machinery

Mounting location	Recommended rating life h		Operating life h	
	Ball bearings			
	from	to	from	to
Self-propelled machinery	1 700	4 000	2 000	6 000
Seasonal machinery	500	1 700	500	2 000

### Construction machinery

Mounting location	Recommended rating life h		Operating life h	
	Ball bearings			
	from	to	from	to
Dozers, loaders	4 000	7 800	5 000	10 000
Excavators, travelling gear	500	1 700	500	2 000
Excavators, slewing gear	1 700	4 000	2 000	5 000
Vibratory road rollers, unbalance generators	1 700	4 000	5 000	30 000
Vibrator bodies	500	1 700	500	2 000

### Rolling mills, steelworks equipment

Mounting location	Recommended rating life h		Operating life h	
	Ball bearings			
	from	to	from	to
Roll stands	500	14 000	2 000	10 000
Rolling mill gearboxes	14 000	32 000	20 000	40 000
Roller tables	7 800	21 000	20 000	40 000
Centrifugal casting machines	21 000	46 000	30 000	60 000

### Conveying equipment

Mounting location	Recommended rating life h		Operating life h	
	Ball bearings			
	from	to	from	to
Belt drives, opencast mining	–	–	10 000	30 000
Conveyor belt rollers, opencast mining	46 000	63 000	10 000	30 000
Conveyor belt rollers, general	7 800	21 000	10 000	30 000
Belt drums	–	–	10 000	30 000
Bucket wheel excavators, travel drive	7 800	21 000	5 000	15 000
Bucket wheel excavators, bucket wheel	–	–	30 000	50 000
Bucket wheel excavators, bucket wheel drive	46 000	83 000	30 000	50 000
Winding cable sheaves	32 000	46 000	50 000	80 000
Sheaves	7 800	21 000	8 000	30 000

# Load carrying capacity and life

## Fans

Mounting location	Recommended rating life h		Operating life h	
	Ball bearings			
	from	to	from	to
Ventilators, fans	21 000	46 000	20 000	100 000
Large fans	32 000	63 000	10 000	–

## Textile machinery

Mounting location	Recommended rating life h		Operating life h	
	Ball bearings			
	from	to	from	to
Spinning machines, spinning spindles	21 000	46 000	10 000	50 000
Weaving and knitting machines	14 000	32 000	10 000	50 000

## Plastics processing

Mounting location	Recommended rating life h		Operating life h	
	Ball bearings			
	from	to	from	to
Plastics worm extruders	14 000	21 000	20 000	100 000
Rubber and plastics calendars	21 000	46 000	20 000	100 000

## Printing machinery

Mounting location	Recommended rating life h		Operating life h	
	Ball bearings			
	from	to	from	to
Printing machinery	32 000	46 000	30 000	60 000

## Operating life

The operating life is defined as the life actually achieved by the bearing. It may differ significantly from the calculated value.

This may be due to wear or fatigue as a result of:

- deviations in the operating data
- misalignment between the shaft and housing
- insufficient or excessive operating clearance
- contamination
- inadequate lubrication
- excessive operating temperature
- oscillating bearing motion with very small angles of oscillation (false brinelling)
- high vibration and false brinelling
- very high shock loads (static overloading)
- prior damage during installation.



Due to the wide variety of possible mounting and operating conditions, it is not possible to precisely predetermine the operating life. The most reliable way of arriving at a close estimate is by comparison with similar applications.



### Static load carrying capacity

If high, static or shock loads occur, the raceways and rolling elements may undergo plastic deformation. These deformations limit the static load carrying capacity of the rolling bearing with respect to the permissible noise level during operation of the bearing.

Rolling bearings that undergo rotary movement only rarely or not at all are specified in accordance with the basic static load rating  $C_0$ . This is, according to DIN ISO 76, a constant radial load  $C_{0r}$  for radial bearings.

The basic static load rating  $C_0$  is that load at which the Hertzian pressure between the rolling elements and the raceways reaches the following values at the most heavily loaded point:

- for ball bearings, 4 200 N/mm<sup>2</sup>.

Under normal contact conditions, this load causes a permanent deformation at the contact points of approx. 1/10 000 of the rolling element diameter.

### Static load safety factor

In addition to specification on the basis of the fatigue life, it is advisable to check the static load safety factor.

The static load safety factor  $S_0$  is the ratio between the basic static load rating  $C_0$  and the equivalent static load  $P_0$ :

$$S_0 = \frac{C_0}{P_0}$$

$S_0$  – Static load safety factor

$C_0$  ( $C_{0r}$ ,  $C_{0a}$ ) N Basic static load rating

$P_0$  ( $P_{0r}$ ,  $P_{0a}$ ) N Equivalent static load on the radial or axial bearing, see page 41.



Guide values and shock loads occurring during operation must be taken into consideration, see table.

### Guide values for the static load safety factor $S_0$

Operating conditions	Static load safety factor $S_0$ for ball bearings
Smooth, low-vibration, normal operation with minimal demands for smooth running; bearings with slight rotary motion	$\cong 0,5$
Normal operation with higher requirements for smooth running	$\cong 1$
Operation with pronounced shock loads	$\cong 2$
Bearing arrangement with high demands for running accuracy and smooth running	$\cong 3$

# Friction and increases in temperature

## Friction

The friction in a rolling bearing is made up of several components, see table. Due to the large number of influencing factors, such as dynamics in speed and load, tilting and skewing resulting from installation, actual frictional torques and frictional power may deviate significantly from the calculated values. If the frictional torque is an important design criterion, please consult the Schaeffler engineering service.

The idling friction is dependent on the lubricant quantity, speed, operating viscosity of the lubricant, seals and the running-in condition of the bearing.

### Frictional component and influencing factor

Frictional component	Influencing factor
Rolling friction	Magnitude of load
Sliding friction of rolling elements, sliding friction of cage	Magnitude and direction of load Speed and lubrication conditions, running-in condition
Fluid friction (flow resistance)	Type and speed Type, quantity and operating viscosity of lubricant
Seal friction	Type and preload of seal

### Further information

Detailed calculation of friction in rolling bearings:

- BEARINX-online Easy Friction, <http://bearinx-online-easy-friction.schaeffler.com>
- publication PBR, BEARINX-online Easy Friction
- download and ordering: <http://medien.schaeffler.de>

### Heat dissipation

Friction is converted into heat. This must be dissipated from the bearing. The equilibrium between the frictional power and heat dissipation allows calculation of the thermally safe operating speed  $n_{\theta}$ , see page 58.

Grease does not give dissipation of heat.

### Heat dissipation via the shaft and housing

Heat dissipation via the shaft and housing is dependent on the temperature differential between the bearing and its environment, *Figure 1*.



Any additional adjacent sources of heat or thermal radiation must be taken into consideration.

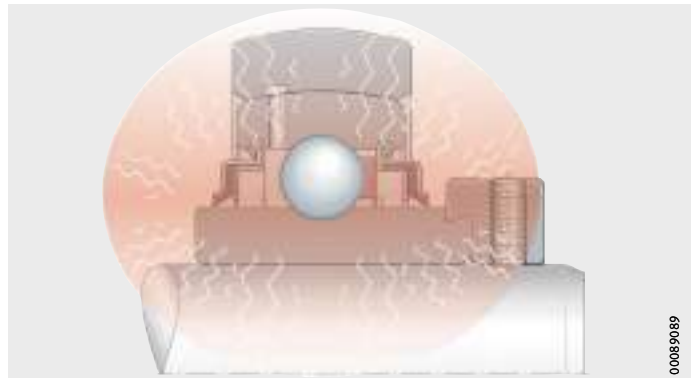

*Figure 1*  
Temperature distribution between bearing, shaft and housing





## Calculation of friction values

For this process, the speed and load must be known. The type of lubrication, lubrication method and viscosity of the lubricant at operating temperature are other factors necessary for calculation.

Total frictional torque  $M_R$ :

$$M_R = M_0 + M_1$$

Frictional power  $N_R$ :

$$N_R = M_R \cdot \frac{n}{9550}$$

Frictional torque as a function of speed for  $\nu \cdot n \geq 2\,000$ :

$$M_0 = f_0 \cdot (\nu \cdot n)^{2/3} \cdot d_M^3 \cdot 10^{-7}$$

Frictional torque as a function of speed for  $\nu \cdot n < 2\,000$ :

$$M_0 = f_0 \cdot 160 \cdot d_M^3 \cdot 10^{-7}$$

Frictional torque as a function of load for ball bearings:

$$M_1 = f_1 \cdot P_1 \cdot d_M$$

$M_R$  Total frictional torque Nmm

$M_0$  Frictional torque as a function of speed Nmm

$M_1$  Frictional torque as a function of load Nmm

$N_R$  Frictional power W

$n$  Operating speed  $\text{min}^{-1}$

$f_0$  Bearing factor for frictional torque as a function of speed, see tables, page 56

$\nu$  Kinematic viscosity of lubricant at operating temperature. In the case of grease, the decisive factor is the viscosity of the base oil at operating temperature

$d_M$  Mean bearing diameter  $(d + D)/2$  mm

$f_1$  Bearing factor for frictional torque as a function of load, see tables, page 56

$P_1$  Decisive load for frictional torque. N

## Friction and increases in temperature

**Bearing factors** The bearing factors  $f_0$  and  $f_1$  are mean values from series of tests and correspond to the data in accordance with ISO 15312. They are valid for bearings after running-in and with uniform distribution of lubricant. In the freshly greased state, the bearing factor  $f_0$  can be two to five times higher.

### Bearing factors for deep groove ball bearings

Series	Bearing factor	
	$f_0$	$f_1$
	Grease	
60	1,1	$0,0007 \cdot (P_0/C_0)^{0,5}$
62	1,3	$0,0009 \cdot (P_0/C_0)^{0,5}$
63	1,5	$0,0009 \cdot (P_0/C_0)^{0,5}$

### Bearing factors for double row angular contact ball bearings

Series	Bearing factor	
	$f_0$	$f_1$
	Grease	
30..-B, 30..-B-2RSR, 30..-B-2Z	2,3	$0,001 \cdot (P_0/C_0)^{0,33}$
32..-B, 32..-B-2RSR, 32..-B-2Z, 32	2,3	$0,001 \cdot (P_0/C_0)^{0,33}$
38..-B, 38..-B-2RSR, 38..-B-2Z	2,3	$0,001 \cdot (P_0/C_0)^{0,33}$
33..-B, 33..-B-2RSR, 33, 33..-DA	4	$0,001 \cdot (P_0/C_0)^{0,33}$

### Decisive load for ball bearings

Bearing type	Load <sup>1)</sup>
	$P_1$
	Single bearing
Deep groove ball bearings	$3,3 \cdot F_a - 0,1 \cdot F_r$
Angular contact ball bearings, double row	$1,4 \cdot F_a - 0,1 \cdot F_r$

1) For  $P_1 \leq F_r$ ,  $P_1 = F_r$ .



# Speeds

## Criteria for speed limitation

The highest permissible speed for a rolling bearing may be restricted by various criteria. The most frequent decisive factor is the increasing operating temperature with increasing speed.

The permissible speed is also dependent on the design of the entire bearing arrangement, in other words the rolling bearing itself, its type, size, accuracy and cage design as well as on the operating conditions. These comprise the magnitude and direction of the load, the lubrication method, the type and quantity of the lubricant, the environment (design layout and accuracy of the adjacent parts) as well as the dissipation of heat via the adjacent parts.

## Limiting speed

The limiting speed  $n_G$  is based on practical experience and takes account of additional criteria such as smooth running, sealing function and centrifugal forces.



The limiting speeds indicated in the dimension tables should not be exceeded even under favourable operating conditions without prior consultation with Schaeffler.

## Thermal reference speed

The thermal reference speed  $n_{\vartheta_r}$  was introduced as a parameter for the speed suitability of rolling bearings. On the basis of DIN 732, calculation of the thermal reference speed  $n_{\vartheta_r}$  has been standardised in ISO 15312.

The thermal reference speed  $n_{\vartheta_r}$  is used as an ancillary value when calculating the thermally safe operating speed  $n_{\vartheta}$ . This is the speed at which, under defined reference conditions, the bearing temperature settles at +70 °C.

The thermal reference speed is not a speed limit for the application of a bearing. It is primarily for the purpose of comparing the speed suitability of different bearing types under defined reference conditions. A speed limit taking account of the thermal balance can be calculated using the thermally safe operating speed.

# Speeds

## Reference conditions

The reference conditions are based on the normal operating conditions of the most significant bearing types and sizes.

They are defined in ISO 15312 as follows:

- reference temperature of the environment of the rolling bearing  $\vartheta_{Ar} = +20 \text{ °C}$
- reference temperature at the stationary outer ring  $\vartheta_r = +70 \text{ °C}$
- radial bearings with nominal contact angle  $0^\circ \leq \alpha_0 \leq 45^\circ$ 
  - The reference load  $P_{1r}$  is 5% of the basic static load rating  $C_0$  as a pure constant radial load
  - $P_{1r} = 0,05 \cdot C_{0r}$
- kinematic viscosity of the lubricant under reference conditions (in the case of radial bearings)  $\nu_r = 12 \text{ mm}^2\text{s}^{-1}$  (ISO VG 32)
- heat dissipation via the bearing seating surfaces, see equations:

## Heat flow density

Radial bearing, bearing seat  $A_r \leq 50\,000 \text{ mm}^2$ :

$$q_r = 0,016 \text{ W/mm}^2$$

Radial bearing, bearing seat  $A_r > 50\,000 \text{ mm}^2$ :

$$q_r = 0,016 \cdot \left( \frac{A_r}{50\,000} \right)^{-0,34} \text{ W/mm}^2$$

## Heat-dissipating reference surface

Bearing seating surface for radial bearings:

$$A_r = \pi \cdot B \cdot (D + d)$$

## Thermally safe operating speed

If the operating conditions deviate from the reference conditions, there will be an increase in friction and thus in heat generation in the rolling bearing.

The method for calculating the thermally safe operating speed  $n_{\vartheta}$  is standardised in DIN 732. On this basis, the thermally safe operating speed is the speed at which, under operating conditions, the mean bearing temperature reaches the permissible value.

Calculation of the thermally safe operating speed  $n_{\vartheta}$  is based on the thermal balance in the rolling bearing. In accordance with the definition of the thermal reference speed according to ISO 15312, the speed is determined at which the rolling bearing reaches the permissible bearing temperature for the application.



For calculation, it is assumed that normal operating clearance and constant operating conditions are present.

In addition to the thermally safe operating speed, the limiting speed  $n_G$  must always be observed.



### Limits of the calculation method

The calculation method is not valid for sealed rolling bearings with contact seals; the maximum speed is restricted by the permissible sliding velocity at the seal lip.

### Calculation of the thermally safe operating speed

The thermally safe operating speed  $n_{\vartheta}$  is a product of the reference speed  $n_{\vartheta r}$  and the speed ratio  $f_n$ :

$$n_{\vartheta} = n_{\vartheta r} \cdot f_n$$

The speed ratio is derived from *Figure 1*, page 60:

$$K_L \cdot f_n^{5/3} + K_p \cdot f_n = 1$$

In the normal operating range of  $0,01 < K_L < 10$  and  $0,01 < K_p < 10$ ,  $f_n$  can be calculated using an approximation equation:

$$f_n = \frac{490,77}{1 + 498,78 \cdot K_L^{0,599} + 852,88 \cdot K_p^{0,963} - 504,5 \cdot K_L^{0,055} \cdot K_p^{0,832}}$$

Heat dissipation via the bearing seating surfaces  $\dot{Q}_S$ , *Figure 2*, page 60:

$$\dot{Q}_S = k_q \cdot A_r \cdot \Delta\vartheta_A$$

Heat dissipation by the lubricant  $\dot{Q}_L$ :

$$\dot{Q}_L = 0,0286 \frac{\text{kW}}{\text{l/min} \cdot \text{K}} \cdot \dot{V}_L \cdot \Delta\vartheta_L$$

Total dissipated heat flow  $\dot{Q}$ :

$$\dot{Q} = \dot{Q}_S + \dot{Q}_L - \dot{Q}_E$$

Lubricant film parameter  $k_L$ :

$$K_L = 10^{-6} \cdot \frac{\pi}{30} \cdot n_{\vartheta r} \cdot \frac{10^{-7} \cdot f_0 \cdot (v \cdot n_{\vartheta r})^2 \cdot d_M^3}{\dot{Q}}$$

Load parameter  $k_p$ :

$$K_p = 10^{-6} \cdot \frac{\pi}{30} \cdot n_{\vartheta r} \cdot \frac{f_1 \cdot P_1 \cdot d_M}{\dot{Q}}$$

# Speeds

$f_n$  = speed ratio  
 $K_L$  = lubricant film parameter  
 $K_p$  = load parameter

**Figure 1**  
 Speed ratio as a function  
 of lubricant film

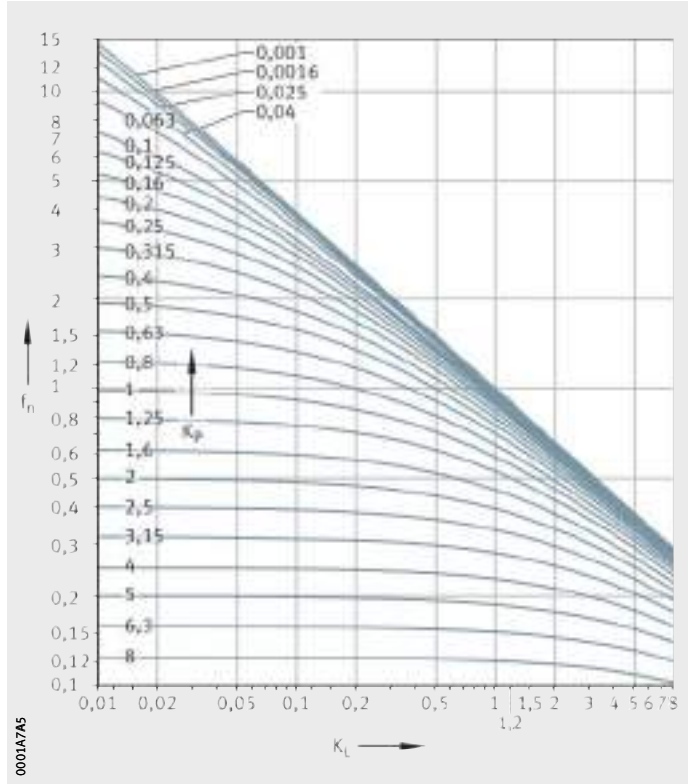

$k_q$  = heat transition coefficient  
 $A_r$  = bearing seating surface

- ① Reference condition for radial bearings
- ② Heat transition coefficient  $k_q$  for normal applications with bearing seating surfaces up to  $A_r = 50\,000\text{ mm}^2$

**Figure 2**  
 Heat transition coefficient,  
 as a function  
 of the bearing seating surface

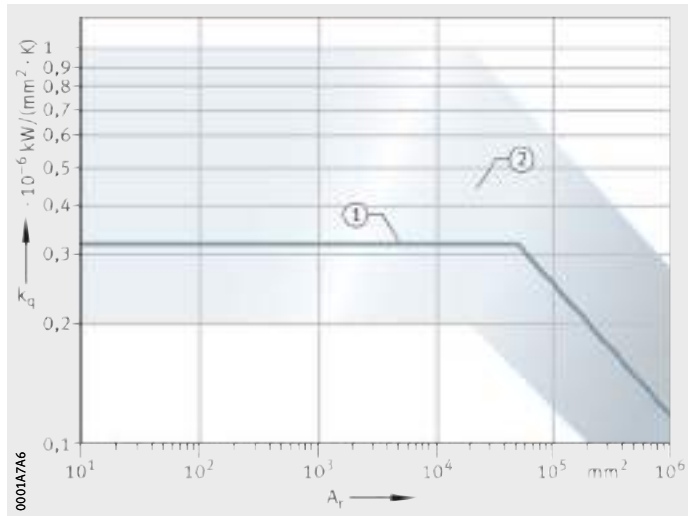



## Symbols, units and definitions

$q_r$	W/mm <sup>2</sup>
Heat flow density	
$A_r$	mm <sup>2</sup>
Bearing seating surface for radial bearings: $A_r = \pi \cdot B \cdot (D + d)$	
$B$	mm
Bearing width	
$D$	mm
Bearing outside diameter	
$d$	mm
Bearing bore diameter	
$n_{\vartheta}$	min <sup>-1</sup>
Thermally safe operating speed	
$n_{\vartheta r}$	min <sup>-1</sup>
Reference speed	
$f_n$	–
Speed ratio, <i>Figure 1</i> , page 60	
$K_L$	–
Lubricant film parameter	
$K_p$	–
Load parameter	
$\dot{Q}_S$	kW
Heat flow dissipated via the bearing seating surfaces	
$k_q$	10 <sup>-6</sup> kW/(mm <sup>2</sup> · K)
Heat transition coefficient of bearing seating surface, <i>Figure 2</i> , page 60. This is dependent on the housing design and size, the housing material and the mounting position. For normal applications, the heat transition coefficient for bearing seating surfaces up to 25 000 mm <sup>2</sup> is between 0,2 · 10 <sup>-6</sup> kW/(mm <sup>2</sup> · K) and 1,0 · 10 <sup>-6</sup> kW/(mm <sup>2</sup> · K)	
$\Delta\vartheta_A$	K
Differential between mean bearing temperature and ambient temperature	
$\dot{Q}_L$	kW
Heat flow dissipated by the lubricant	
$\dot{V}_L$	l/min
Oil flow	
$\Delta\vartheta_L$	K
Differential between oil inlet temperature and oil outlet temperature	
$\dot{Q}$	kW
Total dissipated heat flow	
$\dot{Q}_E$	kW
Heat flow due to heating by external source	
$\nu$	mm <sup>2</sup> · s <sup>-1</sup>
Kinematic viscosity of lubricant at operating temperature	
$d_M$	mm
Mean bearing diameter $(D + d)/2$	
$f_1$	–
Bearing factor for frictional torque as a function of load, see section Friction and increases in temperature, page 54	
$P_1$	N
Radial load for radial bearings, axial load for axial bearings	
$f_0$	–
Bearing factor for frictional torque as a function of speed, see section Friction and increases in temperature, page 54.	

# Lubrication

## Principles

Lubrication and maintenance are important for the reliable operation and long operating life of rolling bearings.

## Functions of the lubricant

The functions of the lubricant are as follows, *Figure 1*:

- A lubricant film is formed on the contact surfaces that is sufficiently capable of supporting loads and thus preventing wear and premature fatigue ①.
- When grease lubrication is used, the bearing is additionally sealed against the entry of both solid and fluid contaminants ②.
- Running noise is damped ③.
- Protection is provided against corrosion ④.

- ① Lubricant film capable of supporting loads
- ② Sealing against contamination
- ③ Damping of noise
- ④ Protection against corrosion

*Figure 1*  
Functions of the lubricant



## Design of lubrication system

Design guidelines for the feed ducts and lubrication holes in the housings and shafts, *Figure 2*:

- They should lead directly to the lubrication hole in the rolling bearing.
- They should be as short as possible.



Follow the guidelines provided by the manufacturers of the lubrication devices.

*Figure 2*  
Design of the lubricant feed system

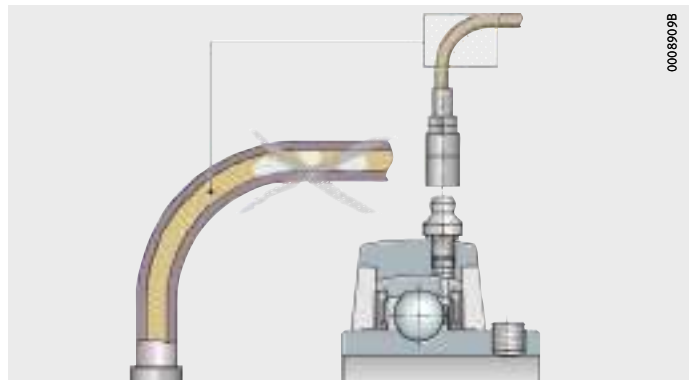





## Grease lubrication

Greases can be differentiated in terms of their thickeners and base oils.

## Composition of a grease

Conventional greases have metal soaps as thickeners and a mineral base oil, *Figure 3*. They also contain additives. These have a specific influence on, for example, the characteristics in relation to wear prevention, anti-corrosion protection or resistance to ageing. These combinations of additives are not, however, fully effective across every temperature and load range.

Greases exhibit widely varying behaviour in response to environmental influences such as temperature and moisture.

- ① Thickener
- ② Additives
- ③ Base oil
- ④ Grease



*Figure 3*  
Type of grease



Lubricants must always be checked for their compatibility in relation to:

- other lubricants
- anti-corrosion agents
- thermoplastics, thermosets and elastomers
- light and non-ferrous metals
- coatings
- colouring agents and paints
- environmental compatibility:
  - toxicity
  - biological degradability
  - water pollution class.

# Lubrication

## Type of grease

The characteristics of a grease are influenced by:

- the base oil
- the viscosity of the base oil (this is important for the speed range)
- the thickener (the shear strength is important for the speed range)
- the additive package.

## Consistency of greases

Greases are subdivided into consistency classes (NLGI grades in accordance with DIN 51818).

For rolling bearings, grades 1, 2, 3 should be used in preference, *Figure 4*.

NLGI grades

*Figure 4*  
Consistency of greases

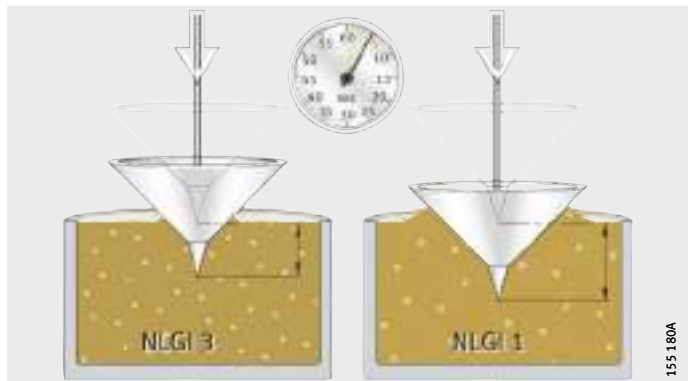

155 180A



## Selection of suitable grease

Rolling bearing greases K in accordance with DIN 51825 are suitable. Greases should be selected in accordance with the operating conditions of the bearing:

- temperature
- compressive load, see page 67
- speed, see page 67
- the presence of water and moisture, see page 67.

## Operating temperature range

The operating temperature range of the grease must correspond to the range of possible operating temperatures in the rolling bearing.

Grease manufacturers indicate an operating temperature range for their rolling bearing greases K in accordance with DIN 51825.

The upper value is determined in accordance with DIN 51821 by means of testing on the FAG rolling bearing grease test rig FE 9. At the upper operating temperature, a 50% failure probability rate ( $F_{50}$ ) of at least 100 hours must be achieved in this test.

The lower value is defined in accordance with DIN 51825 by means of flow pressure. The flow pressure of a grease is the pressure required to press a stream of grease through a defined nozzle. For greases of type K, the flow pressure at the lower operating temperature must be less than 1 400 mbar.

The use of flow pressure in determining the lower operating temperature only indicates, however, whether the grease can be moved at this temperature. This cannot be used to give an indication of its suitability for use in rolling bearings at low temperatures.

In addition to the lower operating temperature of a grease, therefore, the low temperature frictional torque is also determined in accordance with ASTM D 1478 or IP 186/93. At the lower operating temperature, the starting torque must not exceed 1 000 Nmm and the running torque must not exceed 100 Nmm.

# Lubrication

Schaeffler recommends that greases should be used in accordance with the bearing temperature normally occurring in the standard operating range in order to achieve a reliable lubricating action and an acceptable grease operating life, *Figure 5*.

At low temperatures, greases release very little base oil. This can result in lubricant starvation. Schaeffler therefore recommends that greases are not used below the lower continuous limit temperature  $\vartheta_{\text{lowerlimit}}$ , *Figure 5*. This is approx. 20 K above the lower operating temperature of the grease as indicated by grease manufacturers.

The upper continuous limit temperature  $\vartheta_{\text{upperlimit}}$  must not be exceeded if a temperature-induced reduction in the grease operating life is to be avoided, see page 70.



At consistently low temperatures (for example in cold store applications), it must be ensured that the grease releases sufficient oil in relation to the bearing type.

- $\vartheta$  = operating temperature  
 $\Delta T$  = temperature differential
- ① Upper operating temperature according to grease manufacturer
  - ②  $\vartheta_{\text{upperlimit}}$
  - ③  $\vartheta_{\text{lowerlimit}}$
  - ④ Lower operating temperature according to grease manufacturer
  - ⑤ Standard operating range

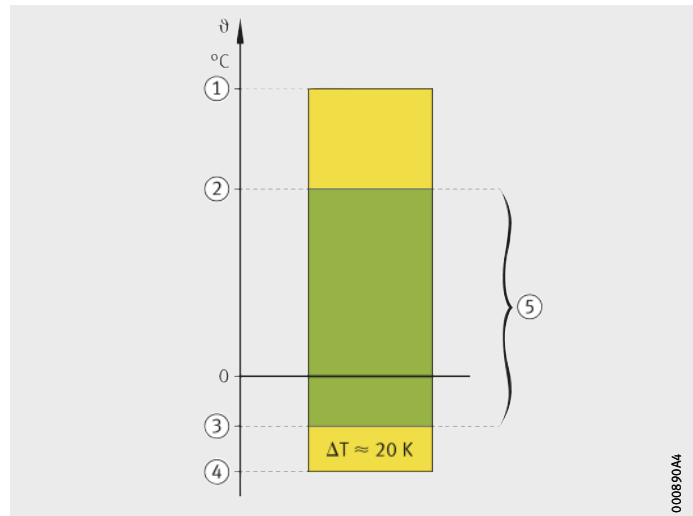

*Figure 5*  
 Operating temperature range



**Pressure capacity** The viscosity at operating temperature must be sufficiently high for the formation of a lubricant film capable of supporting loads. At high loads, greases with EP characteristics (“extreme pressure”) and high base oil viscosity should be used (KP grease in accordance with DIN 51825). Such greases should also be used for bearings with a substantial sliding component and with line contact.



Silicone greases should only be used at low loads ( $P \leq 3\% C$ ). Greases with solid lubricants should preferably be used for applications with mixed or boundary friction conditions. The solid lubricant particle size must not exceed 5  $\mu\text{m}$ .

**Speed** Greases should be selected in accordance with the speed parameter  $n \cdot d_M$  for grease, see table, page 69:

- For rolling bearings running at high speeds or with a low starting torque, greases with a high speed parameter should be used.
- For bearings running at low speeds, greases with a low speed parameter should be used.

Under centrifugal accelerations  $> 500 g$ , separation (of the thickener and base oil) may occur. In this case, please consult the lubricant manufacturer.



The consistency of polycarbamide greases can be altered by shear stresses to a greater extent than that of metal soap greases.

**Water and moisture** Water in the grease has a highly detrimental effect on the operating life of the bearing:

- The static behaviour of greases in the presence of water is assessed in accordance with DIN 51807, *Figure 6*.
- The anti-corrosion characteristics can be tested according to DIN 51802 (Emcor test) (information is given in the datasheets from the grease manufacturers).

- ① Blank
- ② Grease specimen
- ③ Glass slide

*Figure 6*

Behaviour in the presence of water in accordance with DIN 51807

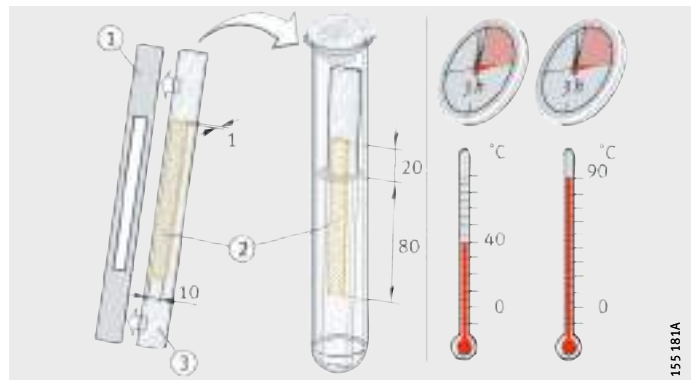

155 181A

# Lubrication

## Greases with special suitability



Many of the rolling bearings supplied by Schaeffler have a grease filling. The greases used have proved particularly suitable for the applications in mechanical-dynamic tests, see table.

When using bearings with plastic cages, compatibility between the lubricant and the cage material must be ensured if synthetic oils, lubricating greases with a synthetic oil base or lubricants containing a high proportion of EP additives are used.

### Greases

Designation <sup>1)</sup>	Classification	Type of grease
<b>GA13</b>	Standard ball bearing and radial insert ball bearing grease for D > 62 mm	Lithium soap Mineral oil
<b>GA22</b>	Free-running grease with low frictional torque	Lithium soap Ester oil
<b>L069<sup>4)</sup></b>	Radial insert ball bearing grease for wide temperature range	Polycarbamide Ester oil
<b>GA11</b>	Rolling bearing grease resistant to media for temperatures up to +250 °C	PTFE Alkoxyfluoroether
<b>GA47</b>	Rolling bearing grease resistant to media for temperatures up to +140 °C	Barium complex soap Mineral oil
<b>L178</b>	Rolling bearing grease for high speeds	Barium complex soap PAO oil

1) GA.. stands for **Grease Application Group**., based on Grease Spec 00.

2) The upper continuous limit temperature  $\vartheta_{upperlimit}$  must not be exceeded if a temperature-induced reduction in grease operating life is to be avoided.

3) Dependent on bearing type.

4) Since January 2008, the grease L069 has been used in radial insert ball bearings instead of L014 and L086.



Operating temperature range °C		Upper continuous limit temperature $\vartheta_{upperlimit}^{2)}$ °C	NLGI grade		Speed parameter $n \cdot d_M$ $min^{-1} \cdot mm$	ISO-VG grade (base oil) <sup>3)</sup>		Designation <sup>1)</sup>	Recommended Arcanol grease for relubrication
from	to		from	to		from	to		
-30	+120	+75	3	-	500 000	68	150	<b>GA13</b>	<b>MULTI3</b>
-50	+120	+70	2	-	1 500 000	10	22	<b>GA22</b>	-
-40	+180	+120	2	-	700 000	68	220	<b>L069<sup>4)</sup></b>	-
-30	+260	+200	2	-	300 000	460	680	<b>GA11</b>	<b>TEMP200</b>
-20	+130	+70	1	2	350 000	150	320	<b>GA47</b>	-
-20	+142	+75	2	-	800 000	22	46	<b>L178</b>	-

### Arcanol rolling bearing greases

For users who wish to charge their rolling bearings with grease themselves, there is a range of particularly suitable Arcanol rolling bearing greases.

These greases are graded in terms of their performance capability such that they can be used to cover almost all areas of application.

# Lubrication

## Grease operating life

The grease operating life  $t_{fG}$  describes the period over which the grease is capable, without relubrication, of lubricating the bearing to an adequate extent. Once the grease operating life has been reached, function of the bearing is only conditionally possible and the bearing will fail relatively quickly as a result of lubricant failure.

The grease operating life is therefore a decisive value if it is shorter than the calculated bearing life. It applies where rolling bearings cannot be relubricated.

It is influenced by the following factors:

- the grease quantity and distribution
- the type of grease (thickener, base oil, additives)
- the production process of the grease
- the bearing type and size
- the magnitude and type of load
- the speed parameter  $n \cdot d_M$
- the bearing temperature
- the mounting conditions.

## Approximation equation for grease operating life

A guide value for the grease operating life  $t_{fG}$  can be determined in approximate terms as follows:

$$t_{fG} = t_f \cdot K_T \cdot K_P \cdot K_R \cdot K_U$$

$t_{fG}$	h
Guide value for grease operating life	
$t_f$	h
Basic grease operating life, see page 71	
$K_T$	–
Correction factor for temperature, see page 72	
$K_P$	–
Correction factor for load, see page 73	
$K_R$	–
Correction factor for oscillation, see page 74	
$K_U$	–
Correction factor for environment, see page 75.	



If the outer ring rotates, there may be a reduction in the grease operating life. If a grease operating life  $> 3$  years is required, this should be agreed in consultation with the lubricant manufacturer.

The grease operating life cannot be determined using the method described in the following cases:

- Air is sucked through the rolling bearing during operation
  - risk of increased grease oxidation.
- Contamination, water or other fluids enter the bearings.
- There is no bearing type factor  $k_f$ , see table, page 71.





### Basic grease operating life

The basic grease operating life  $t_f$  is valid under the following preconditions and is dependent on the bearing-specific speed parameter  $k_f \cdot n \cdot d_M$ , see table and *Figure 7*.

#### Preconditions for the basic grease operating life

	Precondition
Bearing temperature	< upper continuous limit temperature $\vartheta_{upperlimit}$
Load ratio	$C_0/P = 20$
Speed and load	Constant
Load in main direction	Radial bearing, radial
Axis of rotation	Horizontal for radial bearings
Inner ring	Rotating
Environmental influences	No disruptive influences

$k_f$  – Bearing type factor, see table  
 $n$   $\text{min}^{-1}$  Operating speed or equivalent speed  
 $d_M$   $\text{mm}$  Mean bearing diameter  $(d + D)/2$ .

$t_f$  = basic grease operating life  
 $k_f \cdot n \cdot d_M$  = bearing-specific speed parameter

*Figure 7*  
 Calculation of basic grease operating life

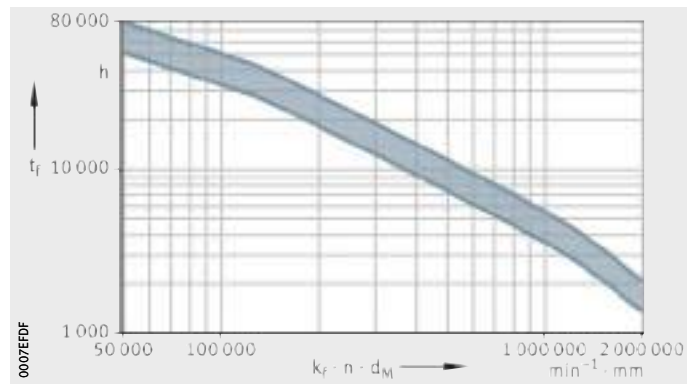

#### Factor $k_f$ , as a function of bearing type

Bearing type	Factor $k_f$
Deep groove ball bearings, single row	1
Angular contact ball bearings, double row	2
Radial insert ball bearings, housing units	1

# Lubrication

## Temperature correction factor $K_T$

The ageing rate of greases increases as the temperature increases above the continuous limit temperature. As a rule of thumb, the following applies: an increase in temperature of 15 K will reduce the grease operating life by half. In the case of high grade greases, however, this effect is only pronounced above the so-called upper continuous limit temperature  $\vartheta_{upperlimit}$ , *Figure 5*, page 66.

If the bearing temperature is above  $\vartheta_{upperlimit}$ , the reduction in the grease operating life due to temperature must be determined, *Figure 8*.



The diagram must not be used if the bearing temperature is higher than the upper operating temperature of the grease used, see table Greases, page 68. If necessary, a different grease must be selected or contact must be made with Schaeffler.

$K_T$  = temperature factor

① K above  $\vartheta_{upperlimit}$

*Figure 8*  
Temperature factor  $K_T$

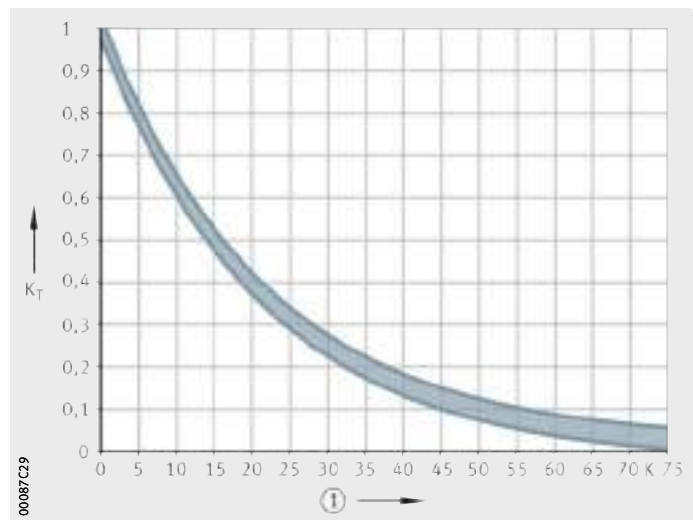



### Load correction factor $K_p$

Under higher bearing load, greases are subjected to greater strain. As a function of the load ratio  $C_0/P$  and the bearing type, this influence can be taken into consideration using the factor  $K_p$ , *Figure 9* and table.

Basis:  
lithium soap greases of high quality

$K_p$  = load factor  
 $C_0/P$  = ratio between basic static load rating and equivalent dynamic bearing load

① Bearing type, see table

*Figure 9*  
 $K_p$  factor for bearings

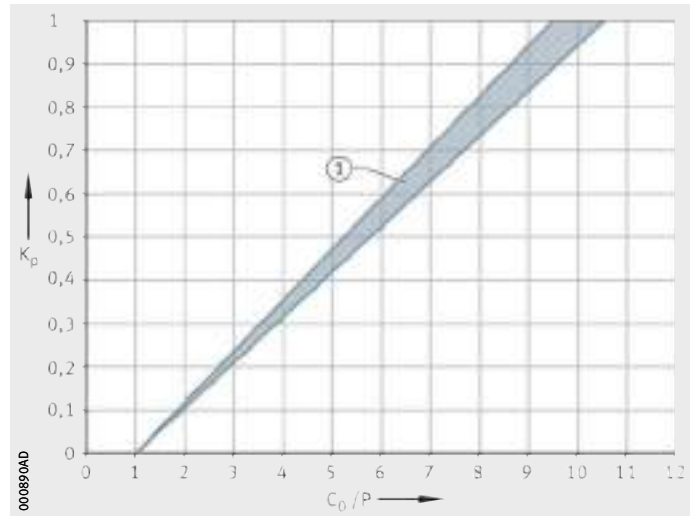

### $K_p$ factor

Curve <sup>1)</sup>	Bearing type
①	Deep groove ball bearings, single row
	Angular contact ball bearings, double row
	Radial insert ball bearings, housing units

<sup>1)</sup> Curves, see *Figure 9*.

# Lubrication

## Oscillation correction factor $K_R$

Oscillating movements place a higher strain on the grease than continuously rotating bearings. The strain is placed continuously on the same grease volume, since no new grease can be drawn into the lubrication contact.



As a result, the grease at the contact becomes depleted. In order to reduce fretting corrosion, the lubrication interval should be reduced. The reduction-inducing influence can be taken into consideration using the oscillation factor  $K_R$ , *Figure 11*.

The factor  $K_R$  has an effect at or above an angle of oscillation  $\varphi < 180^\circ$ , *Figure 10*. At an angle of oscillation  $\varphi < 5^\circ$ , calculation is no longer possible. In this case, special lubricants must be used.

If the rolling elements do not undergo complete rotation, please contact Schaeffler.

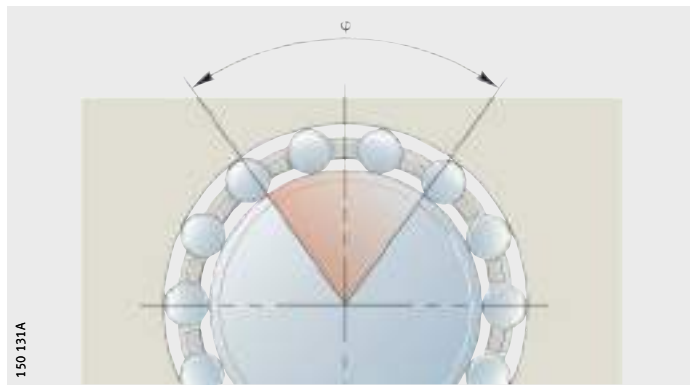

*Figure 10*  
Angle of oscillation  $\varphi$

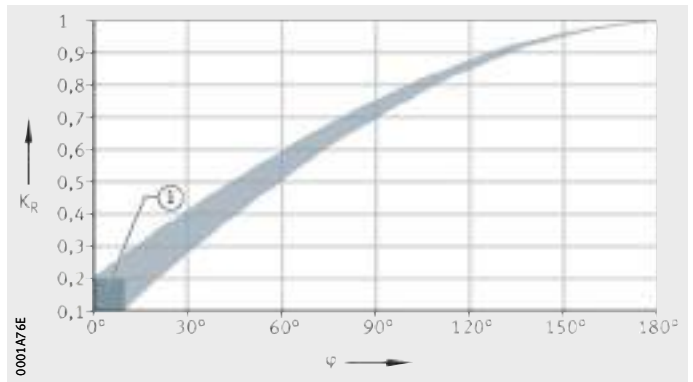

$K_R$  = oscillation factor  
 $\varphi$  = angle of oscillation

① Angle of oscillation  $\varphi < 5^\circ$  requires special lubricants

*Figure 11*  
Oscillation factor  $K_R$



### Environmental correction factor $K_U$

The factor  $K_U$  takes account of the influences of moisture, shaking forces, slight vibration (leading to fretting corrosion) and shocks, see table.



It does not take account of extreme environmental influences such as water, aggressive media, contamination, radiation and extreme vibrations such as those occurring in vibratory machines.

In relation to contamination, the influence of contamination on rating life calculation must also be noted, see section Load carrying capacity and life, page 36.

### Environmental factor $K_U$

Environmental influence	Environmental factor $K_U$
Slight	1
Moderate	0,8
Severe	0,5

# Lubrication

## Relubrication intervals

If rolling bearings are relubricated, attention must be paid to the lubrication interval in order to ensure reliable function of the bearings.



The precise lubrication interval should be determined by tests conducted under application conditions. In this case:

- Sufficiently long observation periods must be selected.
- The condition of the grease must be checked at regular intervals.

For reasons of operational reliability, relubrication intervals  $> 1$  year are not recommended.

## Guide value for relubrication interval

Experience shows that a guide value for most applications is:

$$t_{fR} = 0,5 \cdot t_{fG}$$

$t_{fR}$  h  
Guide value for relubrication interval

$t_{fG}$  h  
Guide value for grease operating life, see page 70.

## Relubrication conditions

The grease used for relubrication must be the same as that used in initial greasing.

If other greases are used, the miscibility and compatibility of the greases must be checked, see page 78.

## Relubrication quantity

Due to the compact construction of the bearings, relubrication should be carried out using 50% to 80% of the initial greasing quantity (recommendation).

If feed lines filled with air are present, the filling volume of the feed lines should be included in calculation of the relubrication quantity.

## Relubrication

Relubrication should always be carried out as follows:

- with the bearing still warm from operation and rotating if safe to do so
- before the bearing comes to rest
- before extended breaks in operation.

Relubrication should continue until a fresh collar of grease appears at the seal gaps. Old grease must be allowed to leave the bearing unhindered.



### Grease reservoir

The initial greasing quantity is between 30% and 50% of the available volume in the bearing, dependent on the bearing type and operating conditions.

A grease reservoir can extend the grease operating life. The grease in the reservoir must be in constant contact with the grease on the raceway. Increasing the size of the grease reservoir does not lead to a proportional increase in the grease operating life.

The volume of the grease reservoir should correspond to the volume within the bearing area between the inner and outer ring (not taking account of the cage and rolling elements), *Figure 12*.

Evaporation of the base oil should be prevented by design measures, for example by sealing washers.

- ① Sealing washer
- ② Grease reservoir

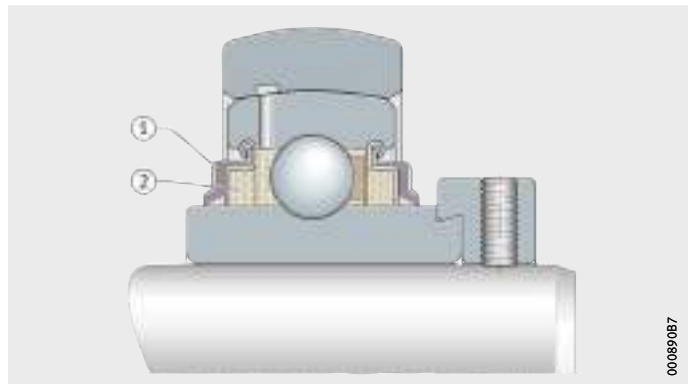

*Figure 12*  
Grease reservoir on both sides

# Lubrication

**Miscibility** Mixtures of greases should be avoided if at all possible.

Preconditions If they are unavoidable, the following preconditions must be fulfilled:

- The base oil must be the same.
- The thickener types must match.
- The base oil viscosities must be similar (they must not differ by more than one ISO-VG grade).
- The consistency must be identical (NLGI grade).



Miscibility of greases must be always be agreed in consultation with the lubricant manufacturer.

Even when these preconditions are fulfilled, impairment of the performance capability of the mixed grease cannot be ruled out.

If a decision is taken to change to a different grease grade, the grease should be rinsed out if this is possible. Further relubrication should be carried out after a shortened period.

If incompatible greases are mixed, this can lead to considerable structural changes. Substantial softening of the grease mixture may also occur.

Definite statements on miscibility can only be obtained by means of suitable tests.

**Storage** Lubricants age due to environmental influences. The information provided by lubricant manufacturers must always be observed.

Preconditions In general, the greases used can be stored for 3 years. The preconditions are:

- a closed room or store
- temperatures between 0 °C and +40 °C
- relative humidity no greater than 65%
- no influence of chemical agents (vapours, gases, fluids)
- sealed rolling bearings.



The start-up frictional torque of greased bearings can be temporarily higher than normal after long periods of storage. The lubricity of the grease may also have deteriorated.

Since the lubrication characteristics of greases vary and different raw materials may be used for greases of the same name, Schaeffler cannot offer any guarantees either for the lubricants used by customers for relubrication or for their characteristics.





# Bearing data

## Radial internal clearance

The radial internal clearance applies to bearings with an inner ring and is determined on the unmounted bearing. It is defined as the amount by which the inner ring can be moved in a radial direction from one extreme position to the other in relation to the outer ring, *Figure 1*.

In accordance with ISO 5753-1 (DIN 620-4), the radial internal clearance is subdivided into groups, *Figure 1* and table.

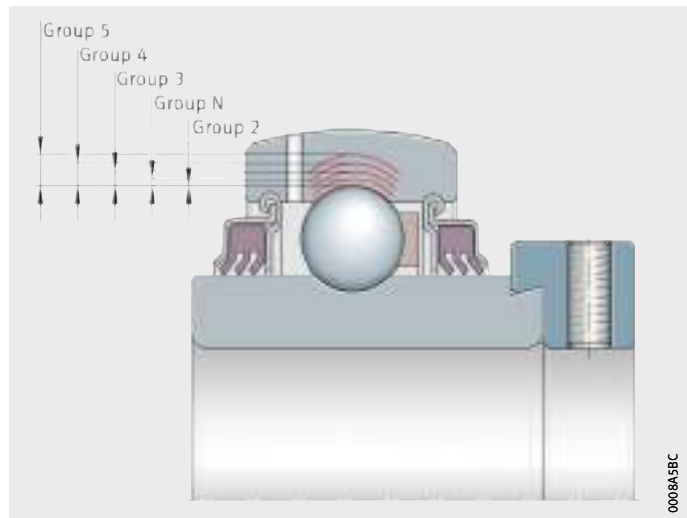

Group N to Group 5 = internal clearance groups

*Figure 1*  
Radial internal clearance

## Radial internal clearance groups

Internal clearance group		Description	Application
DIN 620-4	ISO 5753-1		
CN	Group N	Normal internal clearance; CN is not included in bearing designations	For normal operating conditions with shaft and housing tolerances, see Operating clearance and Design of bearing arrangements
C2	Group 2	Internal clearance < CN	For bearing rings with press fits and large temperature differential between the inner and outer ring
C3	Group 3	Internal clearance > CN	
C4	Group 4	Internal clearance > C3	
C5	Group 5	Internal clearance > C4	

# Bearing data

## Operating clearance

The operating clearance is determined on a mounted bearing still warm from operation. It is defined as the amount by which the shaft can be moved in a radial direction from one extreme position to the other, *Figure 2*.

The operating clearance is derived from the radial internal clearance and the change in the radial internal clearance as a result of interference fit and thermal influences in the mounted condition.

$s$  = operating clearance

*Figure 2*  
Operating clearance

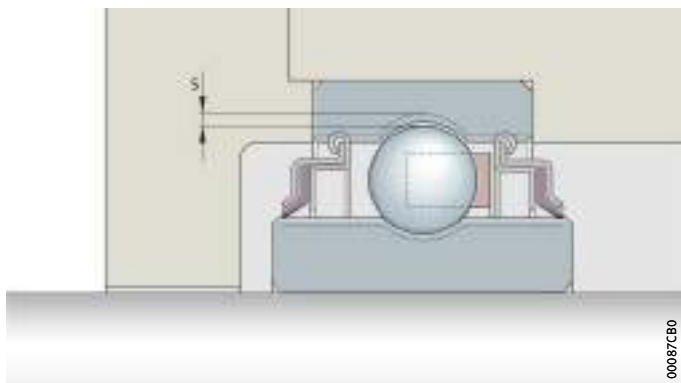

## Operating clearance value

The size of the operating clearance is dependent on the installation and operating conditions of the bearing, see section Design of bearing arrangements, page 100.

A larger operating clearance is, for example, necessary if heat is transferred via the shaft, the shaft undergoes deflection or if misalignment occurs.

An operating clearance smaller than Group N should only be used in special cases, for example in high precision bearing arrangements.

The normal operating clearance is achieved with the internal clearance Group N or, in the case of larger bearings, predominantly with Group 3 if the recommended shaft and housing tolerances are observed, see section Design of bearing arrangements, page 100.

## Calculation of operating clearance

The operating clearance is derived from:

$$s = s_r - \Delta s_p - \Delta s_T$$

$s$	$\mu\text{m}$
Radial operating clearance of mounted bearing warm from operation	
$s_r$	$\mu\text{m}$
Radial internal clearance	
$\Delta s_p$	$\mu\text{m}$
Reduction in radial internal clearance due to fit	
$\Delta s_T$	$\mu\text{m}$
Reduction in radial internal clearance due to temperature.	



### Reduction in radial internal clearance due to fit

The radial internal clearance is reduced due to the fit as a result of expansion of the inner ring and contraction of the outer ring:

$$\Delta S_p = \Delta d + \Delta D$$

$\Delta d$                            $\mu\text{m}$   
Expansion of the inner ring  
 $\Delta D$                            $\mu\text{m}$   
Contraction of the outer ring.

### Expansion of the inner ring

The expansion of the inner ring is calculated as follows:

$$\Delta d \approx 0,9 \cdot U \cdot d/F \approx 0,8 \cdot U$$

$U$                                    $\mu\text{m}$   
Theoretical interference of the fitted parts with firm seating.  
The theoretical oversize of the fitted parts with firm seating is determined from the mean deviations and the upper and lower deviations of the tolerance zones of the fitted parts reduced by  $1/3$  of their acceptable value. This must be reduced by the amount by which parts are smoothed during fitting  
 $d$                                    $\text{mm}$   
Bore diameter of the inner ring  
 $F$                                    $\text{mm}$   
Raceway diameter of the inner ring.



For very thin-walled housings and light metal housings, the reduction in the radial internal clearance must be determined by mounting trials.

### Contraction of the outer ring

The contraction of the outer ring is calculated as follows:

$$\Delta D \approx 0,8 \cdot U \cdot E/D \approx 0,7 \cdot U$$

$E$                                    $\text{mm}$   
Raceway diameter of the outer ring  
 $D$                                    $\text{mm}$   
Outside diameter of the outer ring.

### Reduction in radial internal clearance due to temperature

The radial internal clearance can alter considerably if there is a substantial temperature differential between the inner and outer ring.

$$\Delta S_T = \alpha \cdot d_M \cdot 1\,000 \cdot (\vartheta_{IR} - \vartheta_{AR})$$

$\Delta S_T$                            $\mu\text{m}$   
Reduction in radial internal clearance due to temperature  
 $\alpha$                                    $\text{K}^{-1}$   
Coefficient of thermal expansion of steel:  $\alpha = 0,000011 \text{ K}^{-1}$   
 $d_M$                                    $\text{mm}$   
Mean bearing diameter  $(d + D)/2$   
 $\vartheta_{IR}$                                    $^{\circ}\text{C}, \text{K}$   
Temperature of the inner ring  
 $\vartheta_{AR}$                                    $^{\circ}\text{C}, \text{K}$   
Temperature of the outer ring  
(usual temperature difference between inner and outer ring: 5 K to 10 K).



Where shafts start up quickly, a larger radial internal clearance should be used since adequate thermal compensation between the bearing, shaft and housing does not occur in this situation.  $\Delta S_T$  can, in this case, be significantly higher in this case than for continuous operation.

# Bearing data

## Axial internal clearance

The axial internal clearance  $s_a$  is defined as the amount by which one bearing ring can be moved relative to the other, without load, along the bearing axis, *Figure 3*.

With various bearing types, the radial internal clearance  $s_r$  and the axial internal clearance  $s_a$  are dependent on each other, see table.

$s_a$  = axial internal clearance  
 $s_r$  = radial internal clearance

*Figure 3*  
 Axial internal clearance  
 in comparison  
 with radial internal clearance

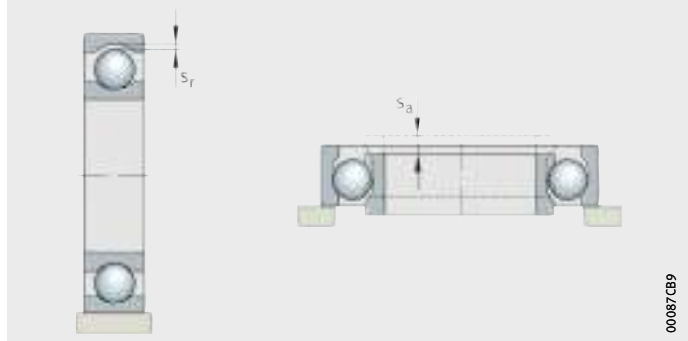

### Correlation between axial internal clearance and radial internal clearance

Bearing type		Ratio between axial and radial internal clearance $s_a/s_r$
Angular contact ball bearings, double row	Series 32 and 33	1,4
	Series 32..-B and 33..-B	2



### Calculation example

The calculation of axial internal clearance is shown in the following example:

Deep groove ball bearing	6008
Radial internal clearance	Group 3
Bore diameter d	40 mm
Radial internal clearance before mounting	15 μm to 33 μm
Actual radial internal clearance	24 μm
Mounting tolerance Shaft	k5 ⊕
Housing	J6 ⊖
Reduction in radial internal clearance during mounting	14 μm
Radial internal clearance after mounting	24 μm - 14 μm = 10 μm
Ratio $s_a/s_r$ , Figure 4	13

Axial internal clearance  $s_a = 13 \cdot 10 \mu\text{m} = 130 \mu\text{m}$

$s_a$  = axial internal clearance  
 $s_r$  = radial internal clearance  
d = bearing bore diameter

① Bearing series

**Figure 4**  
Relationship between radial and axial internal clearance in deep groove ball bearings

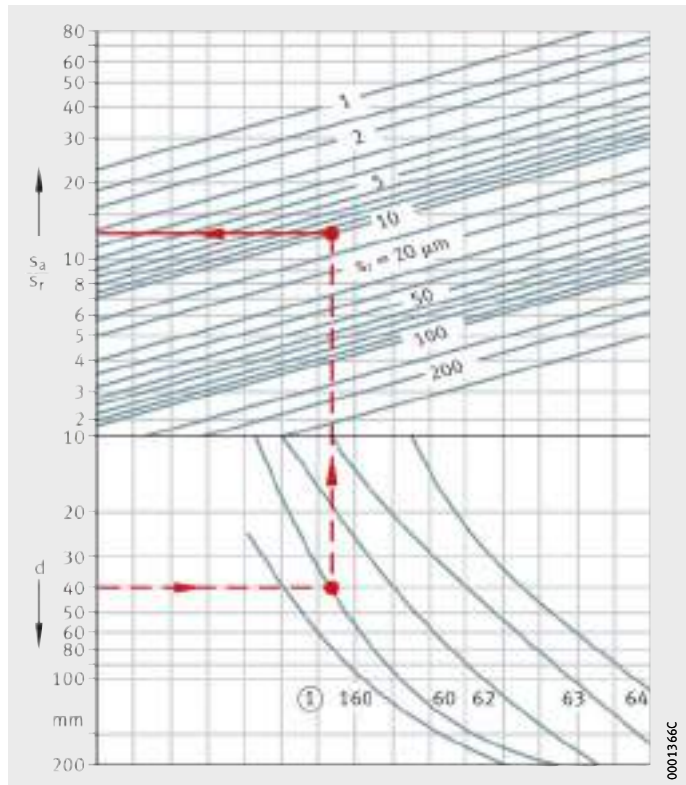

0001366C

# Bearing data

## Bearing materials

INA and FAG rolling bearings fulfil the requirements for fatigue strength, wear resistance, hardness, toughness and structural stability.

The material used for the rings and rolling elements is generally a low-alloy, through hardening chromium steel of high purity.

In recent years, the improved quality of rolling bearing steels has been the principal factor in achieving considerable increases in basic load ratings.

The results of research as well as practical experience confirm that bearings made from the steel currently used as standard can achieve their endurance limit if loads are not excessively high and the lubrication and cleanliness conditions are favourable.

Some suitable materials are listed as examples for some bearing components, see table.

## Materials and bearing components

Material	Bearing component (example)
Through hardening chromium steel ■ Rolling bearing steel in accordance with ISO 683-17	Outer and inner ring, axial washer
Corrosion-resistant steel ■ Rolling bearing steel in accordance with ISO 683-17	Outer and inner ring
Case hardening steel	Locking collar
Polyamide (thermoplastic)	Cage
NBR, PTFE	Sealing ring

## Corrosion-resistant steels

In addition to the standard rolling bearing steels, there is also a corrosion-resistant material for radial insert ball bearings operating in corrosive environments.

The steel SUS440C has been used as standard and proved effective in many applications. This material has adequate corrosion resistance in many media.



**Cages** Rolling bearing cages are subdivided into sheet metal and solid cages.

Both sheet metal and solid cages for radial insert ball bearings are exclusively ball-guided.

The most important functions of the cage are:

- to separate the rolling elements from each other, in order to minimise friction and heat generation
- to maintain the rolling elements at the same distance from each other, in order to ensure uniform load distribution
- to guide the rolling elements in the load zone of the bearing.

### Sheet metal cages

These cages are predominantly made from steel, *Figure 5*. In comparison with solid cages made from metal, they are of lower mass.

Since a sheet metal cage only fills a small proportion of the gap between the inner and outer ring, lubricant can easily reach the interior of the bearing and is held on the cage.

① Riveted cage

*Figure 5*  
Radial insert ball bearing  
with sheet metal cages



## Bearing data

### Solid cages made from polyamide PA66

Solid cages made from polyamide PA66 are produced using the injection moulding process, *Figure 6*. As a result, cage types can generally be realised that allow designs with particularly high load carrying capacity. The elasticity and low mass of polyamide are favourable under shock type bearing loads, high accelerations and decelerations and tilting of the bearing rings in relation to each other. Polyamide cages have very good sliding and emergency running characteristics.

Cages made from glass fibre reinforced polyamide PA66 are suitable for continuous temperatures up to +120 °C.

① Polyamide cage

*Figure 6*  
Solid cage  
made from polyamide







## Operating temperature

Radial insert ball bearings are heat treated such that, depending on their type, they are generally dimensionally stable up to +120 °C (certain series up to +250 °C).

Operating temperatures above +150 °C and up to +250 °C require special heat treatment. Bearings treated in this way are included in the catalogue range and are identified by the suffixes FA101, FA164, see table.



The temperature data in the product descriptions must be observed.

### Suffixes for radial insert ball bearings for high temperatures

Suffix	FA101	FA164
Maximum operating temperature	-40 °C to +180 °C	+150 °C to +250 °C

## Sealed bearings

The permissible temperature for sealed bearings is dependent on the requirements for the operating life of the grease filling and on the action of the contact seals.

Sealed bearings are greased with specially tested, high performance, high quality greases. These greases can withstand +120 °C for short periods. At or above continuous temperatures of +70 °C, a reduction in the operating life of standard greases with a lithium soap base must be expected.

In many cases, adequate operating life values are only achieved at high temperatures through the use of special greases. In these cases, it must also be checked whether seals made from especially heat-resistant materials must be used. The operating limit of normal contact seals is +100 °C.



If high temperature synthetic materials are used for seals and greases, it must be noted that the particularly high performance materials containing fluoride may give off harmful gases and vapours when heated to approx. +300 °C and above. This may occur, for example, if a welding torch is used in the dismantling of a bearing.

## Bearing data

### Anti-corrosion protection

Bearings are not resistant to corrosion by water or agents containing alkalis or acids but are often exposed to these corrosion-inducing agents. In these applications, anti-corrosion protection is therefore a decisive factor in achieving a long operating life of the bearings.

### Anti-corrosion coating system Corrotect

Corrotect is an extremely thin, electroplated surface coating (coating thickness 2  $\mu\text{m}$  to 5  $\mu\text{m}$ ). The coating is effective against moisture, contaminated water, salt spray and weakly alkaline and weakly acidic cleaning agents.



Before bearings with Corrotect coating are mounted, compatibility with media should always be checked.

For lower press-in forces, the surface of the parts should be lightly greased, the tolerances are increased by the thickness of the coating.

### Advantages of the coating

The advantages of the special coating Corrotect are all-round rust protection, including the turned surfaces of chamfers and radii, *Figure 7*. It also gives long term prevention of rust penetration beneath seals and smaller bright spots are protected against rust by the cathodic protection effect. Anti-corrosion protection allows a significantly longer operating life compared to uncoated parts. Uncoated bearings can be easily replaced by coated bearings of the same dimensions and there is no decrease in load carrying capacity (such as occurs in the use of corrosion-resistant steels). During storage, there is no need to use organic-based preservatives.

Test time 24 h in salt spray

- ① With Corrotect coating
- ② Uncoated

*Figure 7*  
Coated and uncoated part  
after the salt spray test





## Dimensional and running tolerances

Unless stated otherwise, the tolerances for radial bearings correspond to ISO 492, *Figure 8*. The rules in ISO 492 and ISO 199 apply.

The accuracy corresponds to the tolerance class Normal.

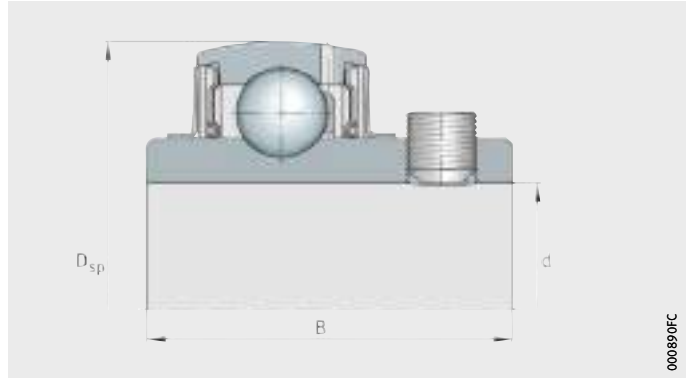

*Figure 8*  
Nominal dimension symbols  
in accordance with  
ISO 492 and ISO 199

## Measurement methods

The definition of the tolerances and the associated measurement principles are described in the following chapter.

The following restrictions apply to the stated specification modifiers:

- The specification modifier  $\text{LP}$  is not indicated on a drawing if the two-point size is defined as the default specification.
- The specification modifier  $\text{GN}$  is not suitable for cases where there is no opposing material, for example the outer ring of a tapered roller bearing with significant edge rounding on the back face and small front face. Solutions must be developed within the framework of the GPS system and taken into consideration in the future.

# Bearing data

Symbols for nominal dimensions, characteristics and specification modifiers for radial rolling bearings in accordance with ISO 492:2014

<b>Symbol for nominal dimension</b> <sup>1) 2)</sup> Tolerance symbol for characteristic <sup>2)</sup>	GPS symbol and specification modifier	Description for radial bearings	Old term
	Symbols in accordance with ISO 1101 and ISO 14405-1	In accordance with ISO 492:2014 (based on ISO 1101, ISO 5459 and ISO 14405-1)	In accordance with ISO 1132-1: 2000
<b>Width</b>			
<b>B</b>	–	Nominal inner ring width	Nominal inner ring width
$t_{\Delta Bs}$	(LP)	<b>Symmetrical rings</b> deviation of a two-point size of inner ring width from its nominal size $\Delta Bs = Bs - B$ $Bs$ = single two-point size of inner ring width	Deviation of a single inner ring width
	(GN)ALS (LP)	<b>Asymmetrical rings, upper limit</b> deviation of a minimum circumscribed size of inner ring width, between two opposite lines, in any longitudinal section which includes the inner ring bore axis, from its nominal size	
	(LP)	<b>Asymmetrical rings, lower limit</b> deviation of a two-point size of inner ring width from its nominal size	
$t_{VBs}$	(LP) (SR)	<b>Symmetrical rings</b> range of two-point sizes of inner ring width $VBs = Bs \text{ max} - Bs \text{ min}$	Variation of inner ring width
	(GN)ALS (SR)	<b>Asymmetrical rings</b> range of minimum circumscribed sizes of inner ring width, between two opposite lines, obtained from any longitudinal section which includes the inner ring bore axis	

1) Symbols for the nominal dimension are printed bold; they indicate size dimensions and spacings.

2) Symbols in accordance with ISO 15241 (exception: font).



**Symbols for nominal dimensions, characteristics and specification modifiers for radial rolling bearings in accordance with ISO 492:2014 (continued)**

<b>Symbol for nominal dimension<sup>1) 2)</sup></b> Tolerance symbol for characteristic <sup>2)</sup>	GPS symbol and specification modifier	Description for radial bearings	Old term
	Symbols in accordance with ISO 1101 and ISO 14405-1	In accordance with ISO 492:2014 (based on ISO 1101, ISO 5459 and ISO 14405-1)	In accordance with ISO 1132-1:2000
<b>Width</b>			
<b>C</b>	–	Nominal outer ring width	Nominal outer ring width
$t_{\Delta Cs}$		<b>Symmetrical rings</b> deviation of a two-point size of outer ring width from its nominal size $\Delta Cs = Cs - C$ $Cs$ = single two-point size of inner ring width	Deviation of a single outer ring width
		<b>Asymmetrical rings, upper limit</b> deviation of a minimum circumscribed size of outer ring width, between two opposite lines, in any longitudinal section which includes the outer ring outside surface axis, from its nominal size	
		<b>Asymmetrical rings, lower limit</b> deviation of a two-point size of outer ring width from its nominal size	
$t_{Vcs}$		<b>Symmetrical rings</b> range of two-point sizes of outer ring width $Vcs = Cs_{max} - Cs_{min}$	Variation of outer ring width
		<b>Asymmetrical rings</b> range of minimum circumscribed sizes of outer ring width, between two opposite lines, obtained from any longitudinal section which includes the outer ring outside surface axis	

1) Symbols for the nominal dimension are printed bold; they indicate size dimensions and spacings.

2) Symbols in accordance with ISO 15241 (exception: font).

## Bearing data

Symbols for nominal dimensions, characteristics and specification modifiers for radial rolling bearings in accordance with ISO 492:2014 (continued)

<b>Symbol for nominal dimension</b> <sup>1) 2)</sup> Tolerance symbol for characteristic <sup>2)</sup>	GPS symbol and specification modifier  Symbols in accordance with ISO 1101 and ISO 14405-1	Description for radial bearings  In accordance with ISO 492:2014 (based on ISO 1101, ISO 5459 and ISO 14405-1)	Old term  In accordance with ISO 1132-1: 2000
<b>Diameter</b>			
<b>d</b>	–	Nominal bore diameter of a cylindrical bore or at the theoretical small end of a tapered bore	Nominal bore diameter
$t_{\Delta ds}$	Ⓐ	Deviation of a two-point size of the bore diameter from its nominal size $\Delta ds = ds - d$	Deviation of a single bore diameter
$t_{Vdsp}$	Ⓐ Ⓡ Ⓐ Ⓐ Ⓐ	Range of two-point sizes of bore diameter in any cross-section of a cylindrical or tapered bore $Vdsp = ds_{max} - ds_{min}$	Variation of single bore diameter in a single plane
$t_{\Delta dmp}$	Ⓐ Ⓢ Ⓐ Ⓐ Ⓐ	<b>Cylindrical bore</b> deviation of a mid-range size (out of two-point sizes) of bore diameter in any cross-section from its nominal size $dmp = (d_{max} + d_{min})/2$ $\Delta dmp = dmp - d$	Deviation of mean bore diameter in a single plane
	Ⓐ Ⓢ Ⓐ Ⓢ Ⓐ	<b>Tapered bore</b> deviation of a mid-range size (out of two-point sizes) of bore diameter at the theoretical small end from its nominal size	
$t_{Vdmp}$	Ⓐ Ⓢ Ⓐ Ⓐ Ⓐ Ⓡ	Range of mid-range sizes (out of two-point sizes) of bore diameter obtained from any cross-section of a cylindrical bore $Vdmp = dmp_{max} - dmp_{min}$	Variation of mean bore diameter

1) Symbols for the nominal dimension are printed bold; they indicate size dimensions and spacings.

2) Symbols in accordance with ISO 15241 (exception: font).









**Symbols for nominal dimensions, characteristics and specification modifiers for radial rolling bearings in accordance with ISO 492:2014 (continued)**

<b>Symbol for nominal dimension<sup>1) 2)</sup></b> Tolerance symbol for characteristic <sup>2)</sup>	GPS symbol and specification modifier	Description for radial bearings	Old term
	Symbols in accordance with ISO 1101 and ISO 14405-1	In accordance with ISO 492:2014 (based on ISO 1101, ISO 5459 and ISO 14405-1)	In accordance with ISO 1132-1:2000
<b>d<sub>1</sub></b>	–	Nominal diameter at the theoretical large end of a tapered bore	–
<i>t<sub>Δd1mp</sub></i>	(LP) (SD) SCS	Deviation of a mid-range size (out of two-point sizes) of bore diameter at the theoretical large end of a tapered bore from its nominal size	–
<b>D</b>	–	Nominal outside diameter	Nominal outside diameter
<i>t<sub>ΔDs</sub></i>	(LP)	Deviation of a two-point size of outside diameter from its nominal size	Deviation of a single outside diameter
<i>t<sub>VDsp</sub></i>	(LP) (SR) ACS	Range of two-point sizes of outside diameter in any cross-section	Variation of outside diameter in a single plane
<i>t<sub>ΔDmp</sub></i>	(LP) (SD) ACS	Deviation of a mid-range size (out of two-point sizes) of outside diameter in any cross-section from its nominal size Dmp = (D max + D min)/2 ΔDmp = Dmp – D	Deviation of mean outside diameter in a single plane
<i>t<sub>VDmp</sub></i>	(LP) (SD) ACS (SR)	Range of mid-range sizes (out of two-point sizes) of outside diameter obtained from any cross-section VDmp = Dmp max – Dmp min	Variation of mean outside diameter

- 1) Symbols for the nominal dimension are printed bold; they indicate size dimensions and spacings.
- 2) Symbols in accordance with ISO 15241 (exception: font).

## Bearing data

Symbols for nominal dimensions, characteristics and specification modifiers for radial rolling bearings in accordance with ISO 492:2014 (continued)

<b>Symbol for nominal dimension<sup>1) 2)</sup></b> Tolerance symbol for characteristic <sup>2)</sup>	GPS symbol and specification modifier	Description for radial bearings	Old term
	Symbols in accordance with ISO 1101 and ISO 14405-1	In accordance with ISO 492:2014 (based on ISO 1101, ISO 5459 and ISO 14405-1)	In accordance with ISO 1132-1:2000
<b>Running accuracy</b>			
$t_{Kea}$	 3)	Circular radial run-out of outer ring outside surface of assembled bearing with respect to datum, i.e. axis, established from the inner ring bore surface	Radial run-out of outer ring of assembled bearing
$t_{Kia}$	 3)	Circular radial run-out of inner ring bore of assembled bearing with respect to datum, i.e. axis, established from the outer ring outside surface	Radial run-out of inner ring of assembled bearing
$t_{Sd}$	 3)	Circular axial run-out of inner ring face with respect to datum, i.e. axis, established from the inner ring bore surface	Perpendicularity of inner ring face with respect to the bore
$t_{SD}$		Perpendicularity of outer ring outside surface axis with respect to datum established from the outer ring face	Perpendicularity of outer ring outside surface with respect to the face
$t_{Sea}$	 3)	Circular axial run-out of outer ring face of assembled bearing with respect to datum, i.e. axis, established from the inner ring bore surface	Axial run-out of outer ring of assembled bearing
$t_{Sia}$	 3)	Circular axial run-out of inner ring face of assembled bearing with respect to datum, i.e. axis, established from the outer ring outside surface	Axial run-out of inner ring of assembled bearing
<b>Tapered bore</b>			
<b>SL</b>	–	Taper slope: Taper slope is the difference between nominal diameters at the theoretical large end and small end of a tapered bore $SL = d_1 - d$ $SL = \text{spacing}$	–
$t_{\Delta SL}$	–	Deviation of taper slope of a tapered inner ring bore from its nominal size (description based on DIN EN ISO 1119) $\Delta SL = \Delta d_{1mp} - \Delta d_{mp}$	–
$\alpha$	–	Frustum angle of tapered inner ring bore	–

1) Symbols for the nominal dimension are printed bold; they indicate size dimensions and spacings.

2) Symbols in accordance with ISO 15241 (exception: font).

3) Specification modifiers for the direction of action of the mass, as well as fixed and movable parts necessary in accordance with ISO/TS 17863.





**Symbols for nominal dimensions, characteristics and specification modifiers for radial rolling bearings in accordance with ISO 492:2014 (continued)**

<b>Symbol for nominal dimension<sup>1) 2)</sup></b> Tolerance symbol for characteristic <sup>2)</sup>	GPS symbol and specification modifier	Description for radial bearings	Old term
	Symbols in accordance with ISO 1101 and ISO 14405-1	In accordance with ISO 492:2014 (based on ISO 1101, ISO 5459 and ISO 14405-1)	In accordance with ISO 1132-1: 2000
<b>Width of assembled bearing</b>			
<b>T</b>	–	Nominal assembled bearing width	Assembled bearing width
$t_{\Delta Ts}$	$\textcircled{GN}$ <sup>3)</sup>	Deviation of minimum circumscribed size of assembled bearing width from its nominal size	Deviation of the actual (assembled) bearing width
<b>T<sub>1</sub></b>	–	Nominal effective width of inner subunit assembled with a master outer ring	Effective width of the inner subunit assembled with a master outer ring
$t_{\Delta T1s}$	$\textcircled{GN}$ <sup>3)</sup>	Deviation of minimum circumscribed size of effective width (inner subunit assembled with a master outer ring) from its nominal size	Nominal effective width of outer ring assembled with a master inner subunit

1) Symbols for the nominal dimension are printed bold; they indicate size dimensions and spacings.

2) Symbols in accordance with ISO 15241 (exception: font).

3) Specification modifiers for the direction of action of the mass, as well as fixed and movable parts necessary in accordance with ISO/TS 17863.

# Bearing data

## Radial bearings

The normal tolerances of radial bearings correspond to ISO 492, see tables. In the case of radial insert ball bearings, only the outside diameter corresponds to the tolerance class Normal in accordance with ISO 492. The inner ring bore has a plus tolerance, see the product description.

### Tolerance class Normal, Inner ring

d		$t_{\Delta dmp}$		$t_{Vdsp}$			$t_{Vdmp}$	$t_{Kia}$
				Diameter series				
mm		$\mu m$		9	0, 1	2, 3, 4	$\mu m$	$\mu m$
		Deviation		$\mu m$	$\mu m$	$\mu m$	$\mu m$	$\mu m$
over	incl.	U	L	max.	max.	max.	max.	max.
0,6 <sup>1)</sup>	2,5	0	-8	10	8	6	6	10
2,5	10	0	-8	10	8	6	6	10
10	18	0	-8	10	8	6	6	10
18	30	0	-10	13	10	8	8	13
30	50	0	-12	15	12	9	9	15
50	80	0	-15	19	19	11	11	20
80	120	0	-20	25	25	15	15	25
120	180	0	-25	31	31	19	19	30
180	250	0	-30	38	38	23	23	40
250	315	0	-35	44	44	26	26	50
315	400	0	-40	50	50	30	30	60
400	500	0	-45	56	56	34	34	65
500	630	0	-50	63	63	38	38	70
630	800	0	-75	-	-	-	-	80
800	1 000	0	-100	-	-	-	-	90
1 000	1 250	0	-125	-	-	-	-	100
1 250	1 600	0	-160	-	-	-	-	120
1 600	2 000	0	-200	-	-	-	-	140

U = upper limit deviation

L = lower limit deviation

Tolerance symbols, see tables, page 90.

<sup>1)</sup> This diameter is included in the group.



**Tolerance class Normal,  
Inner ring  
(continued)**

d mm		t <sub>ΔBs</sub> μm Deviation				t <sub>VBs</sub> μm max.
		normal		modified <sup>1)</sup>		
over	incl.	U	L	U	L	
0,6 <sup>2)</sup>	2,5	0	-40	0	-	12
2,5	10	0	-120	0	-250	15
10	18	0	-120	0	-250	20
18	30	0	-120	0	-250	20
30	50	0	-120	0	-250	20
50	80	0	-150	0	-380	25
80	120	0	-200	0	-380	25
120	180	0	-250	0	-500	30
180	250	0	-300	0	-500	30
250	315	0	-350	0	-500	35
315	400	0	-400	0	-630	40
400	500	0	-450	0	-	50
500	630	0	-500	0	-	60
630	800	0	-750	0	-	70
800	1 000	0	-1 000	0	-	80
1 000	1 250	0	-1 250	0	-	100
1 250	1 600	0	-1 600	0	-	120
1 600	2 000	0	-2 000	0	-	140

U = upper limit deviation

L = lower limit deviation

Tolerance symbols, see tables, page 90.

<sup>1)</sup> Only for bearings manufactured specifically for use as matched pairs.

<sup>2)</sup> This diameter is included in the group.

# Bearing data

Tolerance class Normal,  
Outer ring<sup>1)</sup>

D		t <sub>ΔDmp</sub>		t <sub>ΔDsp</sub>				t <sub>VDmp</sub> <sup>2)</sup>	t <sub>Kea</sub>
				Open bearings Diameter series			Bearings with sealing shields or sealing washers		
				9	0, 1	2, 3, 4			
mm		μm Deviation		μm	μm	μm	μm	μm	
over	incl.	U	L	max.	max.	max.	max.	max.	
2,5 <sup>3)</sup>	6	0	-8	10	8	6	10	6	15
6	18	0	-8	10	8	6	10	6	15
18	30	0	-9	12	9	7	12	7	15
30	50	0	-11	14	11	8	16	8	20
50	80	0	-13	16	13	10	20	10	25
80	120	0	-15	19	19	11	26	11	35
120	150	0	-18	23	23	14	30	14	40
150	180	0	-25	31	31	19	38	19	45
180	250	0	-30	38	38	23	-	23	50
250	315	0	-35	44	44	26	-	26	60
315	400	0	-40	50	50	30	-	30	70
400	500	0	-45	56	56	34	-	34	80
500	630	0	-50	63	63	38	-	38	100
630	800	0	-75	94	94	55	-	55	120
800	1 000	0	-100	125	125	75	-	75	140
1 000	1 250	0	-125	-	-	-	-	-	160
1 250	1 600	0	-160	-	-	-	-	-	190
1 600	2 000	0	-200	-	-	-	-	-	220
2 000	2 500	0	-250	-	-	-	-	-	250

U = upper limit deviation

L = lower limit deviation

Tolerance symbols, see tables, page 90.

<sup>1)</sup> t<sub>ΔCs</sub>, t<sub>ΔC1s</sub>, t<sub>VCs</sub> and t<sub>VC1s</sub> are identical to t<sub>ΔDBs</sub> and t<sub>VBs</sub> for the inner ring of the corresponding bearing, see table, page 96.

<sup>2)</sup> Applies before assembly of the bearing and after removal of internal and/or external snap rings.

<sup>3)</sup> This diameter is included in the group.



## Chamfer dimensions

The chamfer dimensions correspond to DIN 620-6, *Figure 9* and table.

① Arc  
(radius with nominal chamfer dimension)  
beyond which material must not protrude

② Radial

③ Axial

$d$  = inside diameter  
 $r_1, r_2$  = chamfer dimensions

*Figure 9*

Symmetrical ring cross-section  
with identical chamfer dimensions  
on both rings

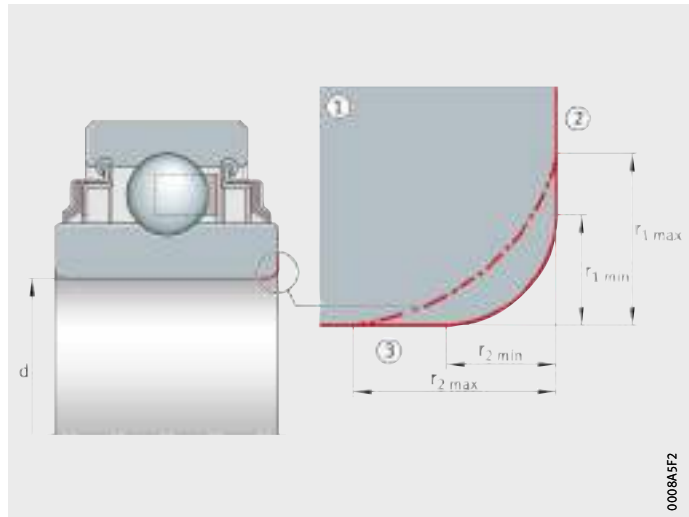

## Limit values for chamfer dimensions to DIN 620-6

Nominal chamfer dimension $r^{1)}$ mm	Nominal bearing bore diameter		Chamfer dimension		
	d mm	incl.	$r_1, r_2$	$r_1$	$r_2$
			mm	mm	mm
0,05	–	–	0,05	0,1	0,2
0,08	–	–	0,08	0,16	0,3
0,1	–	–	0,1	0,2	0,4
0,15	–	–	0,15	0,3	0,6
0,2	–	–	0,2	0,5	0,8
0,3	–	40	0,3	0,6	1
	40	–	0,3	0,8	1
0,5	–	40	0,5	1	2
	40	–	0,5	1,3	2
0,6	–	40	0,6	1	2
	40	–	0,6	1,3	2
1	–	50	1	1,5	3
	50	–	1	1,9	3
1,1	–	120	1,1	2	3,5
	120	–	1,1	2,5	4
1,5	–	120	1,5	2,3	4
	120	–	1,5	3	5
2	–	80	2	3	4,5
	80	220	2	3,5	5
	220	–	2	3,8	6

<sup>1)</sup> The nominal chamfer dimension  $r$  is identical to the smallest permissible chamfer dimension  $r_{\min}$ .

# Design of bearing arrangements

## Conditions of rotation

The conditions of rotation indicate the motion of one bearing ring with respect to the load direction and are expressed as either circumferential load or point load, see table.

### Conditions of rotation

Conditions of motion	Example	Schematic	Load case	Fit
<ul style="list-style-type: none"> <li>■ Rotating inner ring</li> <li>■ Stationary outer ring</li> <li>■ Constant load direction</li> </ul>	Conveyor belts		Circumferential load on inner ring	Inner ring: tight fit necessary Outer ring: loose fit permissible
<ul style="list-style-type: none"> <li>■ Stationary inner ring</li> <li>■ Rotating outer ring</li> <li>■ Load direction rotates with outer ring</li> </ul>	Hub bearing arrangement with significant unbalance		and Point load on outer ring	
<ul style="list-style-type: none"> <li>■ Stationary inner ring</li> <li>■ Rotating outer ring</li> <li>■ Constant load direction</li> </ul>	Roller chain idler sprocket units		Point load on inner ring	Inner ring: loose fit permissible Outer ring: tight fit necessary
<ul style="list-style-type: none"> <li>■ Rotating inner ring</li> <li>■ Stationary outer ring</li> <li>■ Load direction rotates with inner ring</li> </ul>	Centrifuge, vibrating screen		and Circumferential load on outer ring	

### Point load

If the ring remains stationary relative to the load direction, there are no forces that displace the ring relative to its seating surface. This type of loading is described as point load.

There is no risk that the seating surface will be damaged and a loose fit is possible.

### Circumferential load

If forces are present that displace the ring relative to its seating surface, every point on the raceway is subjected to load over the course of one revolution of the bearing. A load with this characteristic is described as a circumferential load.



The following information on design of the bearing arrangement is only applicable to self-aligning deep groove ball bearings and deep groove ball bearings with a cylindrical outer ring.



## Shaft and housing tolerances

The fit is determined by the ISO tolerances for shafts and housings (DIN EN ISO 286-2) in conjunction with the tolerances  $t_{\Delta Dmp}$  for the bore and  $t_{\Delta dmp}$  for the outside diameter of the bearings (ISO 5753-1).

## Tolerance classes

The ISO tolerances are defined in the form of tolerance classes. They are determined by their position relative to the zero line (= tolerance position) and their size (= tolerance grade, see ISO 286-1). The tolerance position is indicated by letters (upper case for housings, lower case for shafts), *Figure 1*.

## Reference to tables of shaft and housing tolerances

The tables contain recommendations for the selection of shaft and housing tolerances that are valid for normal mounting and operating conditions, see page 102.

Deviations are possible if particular requirements apply, for example in relation to running accuracy, smooth running or operating temperature. Increased running accuracies thus require closer tolerances such as tolerance grade 5 instead of 6. If the inner ring is warmer than the shaft during operation, the seating may loosen to an impermissible extent. A tighter fit must then be selected, for example m6 instead of k6.

In such cases, the question of fits can only be resolved by a compromise. The individual requirements must be weighed against each other and those selected that give the best overall solution.

- D = nominal bearing outside diameter
- d = nominal bearing bore diameter
- $t_{\Delta Dmp}$  = deviation of mean bearing outside diameter (in accordance with ISO 492)
- $t_{\Delta dmp}$  = deviation of mean bearing bore diameter (in accordance with ISO 492)

- ① Zero line
- ② Housing
- ③ Shaft
- ④ Clearance fit
- ⑤ Transition fit
- ⑥ Interference fit

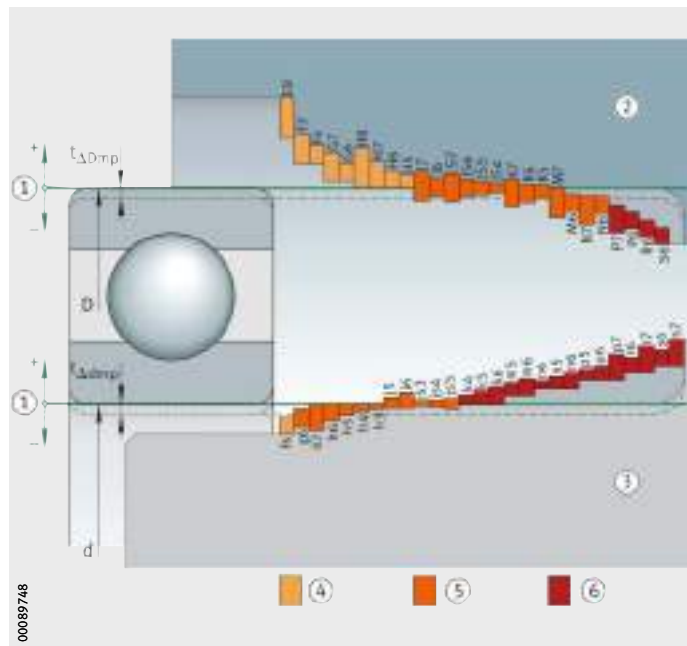

*Figure 1*  
Shaft and housing fits for rolling bearings

# Design of bearing arrangements

## Shaft tolerances for radial bearings with cylindrical bore

Conditions of rotation	Bearing type	Shaft diameter mm	Displacement facility Load	Tolerance class <sup>1)</sup>
Point load on inner ring	Ball bearings	All sizes	Inner ring easily displaced	g6 (g5)
			Inner ring not easily displaced	h6 (j5)
Circumferential load on inner ring or indeterminate load direction	Ball bearings	up to 50	Normal loads <sup>2)</sup>	j6 (j5)
		50 to 100	Low loads <sup>3)</sup>	j6 (j5)
			Normal and high loads <sup>4)</sup>	k6 (k5)
		100 to 200	Low loads <sup>2)</sup>	k6 (m6)
			Normal and high loads <sup>5)</sup>	m6 (m5)
		over 200	Low loads	m6 (m5)
Normal and high loads	n6 (n5)			

1) The envelope condition © applies here.

2)  $C/P > 10$ .

3)  $C/P > 12$ .

4)  $C/P < 12$ .

5)  $C/P < 10$ .

## Housing tolerances for radial bearings

Conditions of rotation	Displacement facility Load	Operating conditions	Tolerance class <sup>1)</sup>
Point load on outer ring	Outer ring not easily displaced Housing unsplit	Normal running accuracy	H7 (j7)
Circumferential load on outer ring or indeterminate load direction	Low loads Outer ring cannot be displaced	For high running accuracy requirements: K6, M6, N6 and P6	K7

1) The envelope condition © applies here.





### Tables of shaft and housing fits

The numerical values for the fits are valid for solid steel shafts and cast housings, see tables, page 104 to page 108. In the table header, below the nominal diameters, are the normal tolerances for the bore or outside diameters of radial bearings. Below these are the deviations for the most important tolerance classes for mounting of rolling bearings.

In each cell are five numbers in accordance with the following scheme, for example for shaft  $\varnothing 40$  j5  $\text{\textcircled{E}}$ , see table, page 104:

#### Example of table entry Shaft fit

Shaft deviation $\mu\text{m}$		Fit interference or fit clearance $\mu\text{m}$	
Maximum material value	+6	<b>18</b> <sup>1)</sup>	Interference or fit clearance if the maximum material values are combined
		<b>10</b> <sup>1)2)</sup>	Probable interference or fit clearance
Minimum material value	-5	5 <sup>3)</sup>	Interference or fit clearance if the minimum material values are combined

1) Values printed in bold type indicate fit interference.

2) The probable interference or fit clearance is the value obtained if the actual dimensions are one third away from the maximum material values.

3) Values printed in regular type indicate fit clearance.

In each cell are five numbers in accordance with the following scheme, for example for housing  $\varnothing 100$  K6  $\text{\textcircled{E}}$ , see table, page 108:

#### Example of table entry Housing fit

Housing deviation $\mu\text{m}$		Fit interference or fit clearance $\mu\text{m}$	
Minimum material value	+4	<b>18</b> <sup>1)</sup>	Interference or fit clearance if the maximum material values are combined
		<b>6</b> <sup>1)2)</sup>	Probable interference or fit clearance
Maximum material value	-18	19 <sup>3)</sup>	Interference or fit clearance if the minimum material values are combined

1) Values printed in bold type indicate fit interference.

2) The probable interference or fit clearance is the value obtained if the actual dimensions are one third away from the maximum material values.

3) Values printed in regular type indicate fit clearance.

# Design of bearing arrangements

## Shaft fits

Nominal shaft diameter in mm													
over incl.	<b>3</b> <b>6</b>	<b>6</b> <b>10</b>	<b>10</b> <b>18</b>	<b>18</b> <b>30</b>	<b>30</b> <b>50</b>	<b>50</b> <b>65</b>							
Deviation of bearing bore diameter in $\mu\text{m}$ (tolerance class Normal)													
$t_{\Delta\text{dmp}}$	0 -8	0 -8	0 -8	0 -10	0 -12	0 -15							
Shaft deviation, fit interference or fit clearance in $\mu\text{m}$													
Clear- ance fit	<b>f6</b>	-10 -18	2 7 18	-13 -22	5 11 22	-16 -27	8 15 27	-20 -33	10 17 33	-25 -41	13 22 41	-30 -49	15 26 49
	<b>g5</b>	-4 -9	<b>4</b> <b>0</b> 9	-5 -11	<b>3</b> 2 11	-6 -14	2 3 14	-7 -16	<b>3</b> 3 16	-9 -20	<b>3</b> 5 20	-10 -23	<b>5</b> 4 23
Transition fit	<b>g6</b>	-4 -12	<b>4</b> 1 12	-5 -14	<b>3</b> 3 14	-6 -17	2 4 17	-7 -20	<b>3</b> 5 20	-9 -25	<b>3</b> 6 25	-10 -29	<b>5</b> 6 29
	<b>h5</b>	0 -5	<b>8</b> <b>4</b> 5	0 -6	<b>8</b> <b>3</b> 6	0 -8	<b>8</b> <b>3</b> 8	0 -9	<b>10</b> <b>4</b> 9	0 -11	<b>12</b> <b>4</b> 11	0 -13	<b>15</b> <b>6</b> 13
	<b>h6</b>	0 -8	<b>8</b> <b>3</b> 8	0 -9	<b>8</b> 2 9	0 -11	<b>8</b> 2 11	0 -13	<b>10</b> 2 13	0 -16	<b>12</b> <b>3</b> 16	0 -19	<b>15</b> <b>4</b> 19
	<b>j5</b>	+3 -2	<b>11</b> 7 2	+4 -2	<b>12</b> 7 2	+5 -3	<b>13</b> 7 3	+5 -4	<b>15</b> 9 4	+6 -5	<b>18</b> <b>10</b> 5	+6 -7	<b>21</b> <b>12</b> 7
	<b>j6</b>	+6 -2	<b>14</b> <b>8</b> 2	+7 -2	<b>15</b> 9 2	+8 -3	<b>16</b> <b>10</b> 3	+9 -4	<b>19</b> <b>11</b> 4	+11 -5	<b>23</b> <b>14</b> 5	+12 -7	<b>27</b> <b>16</b> 7
	<b>js5</b>	+2,5 -2,5	<b>11</b> <b>6</b> 3	+3 -3	<b>11</b> <b>6</b> 3	+4 -4	<b>12</b> <b>6</b> 4	+4,5 -4,5	<b>15</b> <b>9</b> 5	+5,5 -5,5	<b>18</b> <b>10</b> 6	+6,5 -6,5	<b>22</b> <b>13</b> 7
	<b>js6</b>	+4 -4	<b>12</b> 7 4	+4,5 -4,5	<b>13</b> 7 5	+5,5 -5,5	<b>14</b> <b>8</b> 6	+6,5 -6,5	<b>17</b> <b>9</b> 7	+8 -8	<b>20</b> <b>11</b> 8	+9,5 -9,5	<b>25</b> <b>13</b> 10
	Interference fit	<b>k5</b>	+6 +1	<b>14</b> <b>9</b> 1	+7 +1	<b>15</b> <b>10</b> 1	+9 +1	<b>17</b> <b>12</b> 1	+11 +2	<b>21</b> <b>15</b> 2	+13 +2	<b>25</b> <b>17</b> 2	+15 +2
<b>k6</b>		+9 +1	<b>17</b> <b>11</b> 1	+10 +1	<b>18</b> <b>12</b> 1	+12 +1	<b>20</b> <b>14</b> 1	+15 +2	<b>25</b> <b>17</b> 2	+18 +2	<b>30</b> <b>21</b> 2	+21 +2	<b>36</b> <b>25</b> 2
<b>m5</b>		+9 +4	<b>17</b> <b>13</b> 4	+12 +6	<b>20</b> <b>15</b> 6	+15 +7	<b>23</b> <b>18</b> 7	+17 +8	<b>27</b> <b>21</b> 8	+20 +9	<b>32</b> <b>24</b> 9	+24 +11	<b>39</b> <b>30</b> 11
<b>m6</b>		+12 +4	<b>20</b> <b>15</b> 4	+15 +6	<b>23</b> <b>17</b> 6	+18 +7	<b>26</b> <b>20</b> 7	+21 +8	<b>31</b> <b>23</b> 8	+25 +9	<b>37</b> <b>27</b> 9	+30 +11	<b>45</b> <b>34</b> 11

Example: shaft  $\varnothing 40$  j5  $\oplus$

Maximum material value | +6 | **18** | Interference or fit clearance if the maximum material values are combined.  
 Probable interference or fit clearance.  
 Minimum material value | -5 | **5** | Interference or fit clearance if minimum material values are combined. Values **in bold type** in the group of three indicate fit interference, values in normal type indicate fit clearance.



<b>65</b>		<b>80</b>		<b>100</b>		<b>120</b>		<b>140</b>		<b>160</b>		<b>180</b>		<b>200</b>		<b>220</b>	
<b>80</b>		<b>100</b>		<b>120</b>		<b>140</b>		<b>160</b>		<b>180</b>		<b>200</b>		<b>220</b>		<b>250</b>	
0		0		0		0		0		0		0		0		0	
-15		-20		-20		-25		-25		-25		-30		-30		-30	
-30	15	-36	16	-36	16	-43	18	-43	18	-43	18	-50	20	-50	20	-50	20
-49	26	-58	30	-58	30	-68	34	-68	34	-68	34	-79	40	-79	40	-79	40
	49		58		58		68		68		68		79		79		79
-10	<b>5</b>	-12	<b>8</b>	-12	<b>8</b>	-14	<b>11</b>	-14	<b>11</b>	-14	<b>11</b>	-15	<b>15</b>	-15	<b>15</b>	-15	<b>15</b>
-23	4	-27	4	-27	4	-32	3	-32	3	-32	3	-35	2	-35	2	-35	2
	23		27		27		32		32		32		35		35		35
-10	<b>5</b>	-12	<b>8</b>	-12	<b>8</b>	-14	<b>11</b>	-14	<b>11</b>	-14	<b>11</b>	-15	<b>15</b>	-15	<b>15</b>	-15	<b>15</b>
-29	6	-34	6	-34	6	-39	6	-39	6	-39	6	-44	5	-44	5	-44	5
	29		34		34		39		39		39		44		44		44
0	<b>15</b>	0	<b>20</b>	0	<b>20</b>	0	<b>25</b>	0	<b>25</b>	0	<b>25</b>	0	<b>30</b>	0	<b>30</b>	0	<b>30</b>
-13	6	-15	8	-15	8	-18	11	-18	11	-18	11	-20	13	-20	13	-20	13
	13		15		15		18		18		18		20		20		20
0	<b>15</b>	0	<b>20</b>	0	<b>20</b>	0	<b>25</b>	0	<b>25</b>	0	<b>25</b>	0	<b>30</b>	0	<b>30</b>	0	<b>30</b>
-19	4	-22	6	-22	6	-25	8	-25	8	-25	8	-29	10	-29	10	-29	10
	19		22		22		25		25		25		29		29		29
+6	<b>21</b>	+6	<b>26</b>	+6	<b>26</b>	+7	<b>32</b>	+7	<b>32</b>	+7	<b>32</b>	+7	<b>37</b>	+7	<b>37</b>	+7	<b>37</b>
-7	12	-9	14	-9	14	-11	18	-11	18	-11	18	-13	20	-13	20	-13	20
	7		9		9		11		11		11		13		13		13
+12	<b>27</b>	+13	<b>33</b>	+13	<b>33</b>	+14	<b>39</b>	+14	<b>39</b>	+14	<b>39</b>	+16	<b>46</b>	+16	<b>46</b>	+16	<b>46</b>
-7	16	-9	19	-9	19	-11	22	-11	22	-11	22	-13	26	-13	26	-13	26
	7		9		9		11		11		11		13		13		13
+6,5	<b>22</b>	+7,5	<b>28</b>	+7,5	<b>28</b>	+9	<b>34</b>	+9	<b>34</b>	+9	<b>34</b>	+10	<b>40</b>	+10	<b>40</b>	+10	<b>40</b>
-6,5	13	-7,5	16	-7,5	16	-9	20	-9	20	-9	20	-10	23	-10	23	-10	23
	7		8		8		9		9		9		10		10		10
+9,5	<b>25</b>	+11	<b>31</b>	+11	<b>31</b>	+12,5	<b>38</b>	+12,5	<b>38</b>	+12,5	<b>38</b>	+14,5	<b>45</b>	+14,5	<b>45</b>	+14,5	<b>45</b>
-9,5	13	-11	17	-11	17	-12,5	21	-12,5	21	-12,5	21	-14,5	25	-14,5	25	-14,5	25
	10		11		11		13		13		13		15		15		15
+15	<b>30</b>	+18	<b>38</b>	+18	<b>38</b>	+21	<b>46</b>	+21	<b>46</b>	+21	<b>46</b>	+24	<b>54</b>	+24	<b>54</b>	+24	<b>54</b>
+2	21	+3	26	+3	26	+3	32	+3	32	+3	32	+4	37	+4	37	+4	37
	2		3		3		3		3		3		4		4		4
+21	<b>36</b>	+25	<b>45</b>	+25	<b>45</b>	+28	<b>53</b>	+28	<b>53</b>	+28	<b>53</b>	+33	<b>63</b>	+33	<b>63</b>	+33	<b>63</b>
+2	25	+3	31	+3	31	+3	36	+3	36	+3	36	+4	43	+4	43	+4	43
	2		3		3		3		3		3		4		4		4
+24	<b>39</b>	+28	<b>48</b>	+28	<b>48</b>	+33	<b>58</b>	+33	<b>58</b>	+33	<b>58</b>	+37	<b>67</b>	+37	<b>67</b>	+37	<b>67</b>
+11	30	+13	36	+13	36	+15	44	+15	44	+15	44	+17	50	+17	50	+17	50
	11		13		13		15		15		15		17		17		17
+30	<b>45</b>	+35	<b>55</b>	+35	<b>55</b>	+40	<b>65</b>	+40	<b>65</b>	+40	<b>65</b>	+46	<b>76</b>	+46	<b>76</b>	+46	<b>76</b>
+11	34	+13	42	+13	42	+15	48	+15	48	+15	48	+17	56	+17	56	+17	56
	11		13		13		15		15		15		17		17		17

# Design of bearing arrangements

## Shaft fits (continued)

Nominal shaft diameter in mm													
over incl.	3 6	6 10	10 18	18 30	30 50	50 65							
Deviation of bearing bore diameter in $\mu\text{m}$ (tolerance class Normal)													
$t_{\Delta\text{dmp}}$	0 -8	0 -8	0 -8	0 -10	0 -12	0 -15							
Shaft deviation, fit interference or fit clearance in $\mu\text{m}$													
Interference fit	<b>n5</b>	+13 +8	<b>21</b> <b>17</b> <b>8</b>	+16 +10	<b>24</b> <b>19</b> <b>10</b>	+20 +12	<b>28</b> <b>23</b> <b>12</b>	+24 +15	<b>34</b> <b>28</b> <b>15</b>	+28 +17	<b>40</b> <b>32</b> <b>17</b>	+33 +20	<b>48</b> <b>39</b> <b>20</b>
	<b>n6</b>	+16 +8	<b>24</b> <b>19</b> <b>8</b>	+19 +10	<b>27</b> <b>21</b> <b>10</b>	+23 +12	<b>31</b> <b>25</b> <b>12</b>	+28 +15	<b>38</b> <b>30</b> <b>15</b>	+33 +17	<b>45</b> <b>36</b> <b>17</b>	+39 +20	<b>54</b> <b>43</b> <b>20</b>
	<b>p6</b>	+20 +12	<b>28</b> <b>23</b> <b>12</b>	+24 +15	<b>32</b> <b>26</b> <b>15</b>	+29 +18	<b>37</b> <b>31</b> <b>18</b>	+35 +22	<b>45</b> <b>37</b> <b>22</b>	+42 +26	<b>54</b> <b>45</b> <b>26</b>	+51 +32	<b>66</b> <b>55</b> <b>32</b>
	<b>p7</b>	+24 +12	<b>32</b> <b>25</b> <b>12</b>	+30 +15	<b>38</b> <b>30</b> <b>15</b>	+36 +18	<b>44</b> <b>35</b> <b>18</b>	+43 +22	<b>53</b> <b>43</b> <b>22</b>	+51 +26	<b>63</b> <b>51</b> <b>26</b>	+62 +32	<b>77</b> <b>62</b> <b>32</b>
	<b>r6</b>	+23 +15	<b>31</b> <b>25</b> <b>15</b>	+28 +19	<b>36</b> <b>30</b> <b>19</b>	+34 +23	<b>42</b> <b>35</b> <b>23</b>	+41 +28	<b>51</b> <b>44</b> <b>28</b>	+50 +34	<b>62</b> <b>53</b> <b>34</b>	+60 +41	<b>75</b> <b>64</b> <b>41</b>
	<b>r7</b>	+27 +15	<b>35</b> <b>28</b> <b>15</b>	+34 +19	<b>42</b> <b>34</b> <b>19</b>	+41 +23	<b>49</b> <b>40</b> <b>23</b>	+49 +28	<b>59</b> <b>49</b> <b>28</b>	+59 +34	<b>71</b> <b>59</b> <b>34</b>	+71 +41	<b>86</b> <b>71</b> <b>41</b>
	<b>s6</b>	+27 +19	<b>35</b> <b>30</b> <b>19</b>	+32 +23	<b>40</b> <b>34</b> <b>23</b>	+39 +28	<b>47</b> <b>41</b> <b>28</b>	+48 +35	<b>58</b> <b>50</b> <b>35</b>	+59 +43	<b>71</b> <b>62</b> <b>43</b>	+72 +53	<b>87</b> <b>76</b> <b>53</b>

Values in **bold type** in the group of three indicate fit interference, values in normal type indicate fit clearance.



65		80		100		120		140		160		180		200		220	
80		100		120		140		160		180		200		220		250	
0		0		0		0		0		0		0		0		0	
-15		-20		-20		-25		-25		-25		-30		-30		-30	
+33	<b>48</b>	+38	<b>58</b>	+38	<b>58</b>	+45	<b>70</b>	+45	<b>70</b>	+45	<b>70</b>	+51	<b>81</b>	+51	<b>81</b>	+51	<b>81</b>
+20	<b>39</b>	+23	<b>46</b>	+23	<b>46</b>	+27	<b>56</b>	+27	<b>56</b>	+27	<b>56</b>	+31	<b>64</b>	+31	<b>64</b>	+31	<b>64</b>
	<b>20</b>		<b>23</b>		<b>23</b>		<b>27</b>		<b>27</b>		<b>27</b>		<b>31</b>		<b>31</b>		<b>31</b>
+39	<b>54</b>	+45	<b>65</b>	+45	<b>65</b>	+52	<b>77</b>	+52	<b>77</b>	+52	<b>77</b>	+60	<b>90</b>	+60	<b>90</b>	+60	<b>90</b>
+20	<b>43</b>	+23	<b>51</b>	+23	<b>51</b>	+27	<b>60</b>	+27	<b>60</b>	+27	<b>60</b>	+31	<b>70</b>	+31	<b>70</b>	+31	<b>70</b>
	<b>20</b>		<b>23</b>		<b>23</b>		<b>27</b>		<b>27</b>		<b>27</b>		<b>31</b>		<b>31</b>		<b>31</b>
+51	<b>66</b>	+59	<b>79</b>	+59	<b>79</b>	+68	<b>93</b>	+68	<b>93</b>	+68	<b>93</b>	+79	<b>109</b>	+79	<b>109</b>	+79	<b>109</b>
+32	<b>55</b>	+37	<b>65</b>	+37	<b>65</b>	+43	<b>76</b>	+43	<b>76</b>	+43	<b>76</b>	+50	<b>89</b>	+50	<b>89</b>	+50	<b>89</b>
	<b>32</b>		<b>37</b>		<b>37</b>		<b>43</b>		<b>43</b>		<b>43</b>		<b>50</b>		<b>50</b>		<b>50</b>
+62	<b>77</b>	+72	<b>92</b>	+72	<b>92</b>	+83	<b>108</b>	+83	<b>108</b>	+83	<b>108</b>	+96	<b>126</b>	+96	<b>126</b>	+96	<b>126</b>
+32	<b>62</b>	+37	<b>73</b>	+37	<b>73</b>	+43	<b>87</b>	+43	<b>87</b>	+43	<b>87</b>	+50	<b>101</b>	+50	<b>101</b>	+50	<b>101</b>
	<b>32</b>		<b>37</b>		<b>37</b>		<b>43</b>		<b>43</b>		<b>43</b>		<b>50</b>		<b>50</b>		<b>50</b>
+62	<b>77</b>	+73	<b>93</b>	+76	<b>96</b>	+88	<b>113</b>	+90	<b>115</b>	+93	<b>118</b>	+106	<b>136</b>	+109	<b>139</b>	+113	<b>143</b>
+43	<b>66</b>	+51	<b>79</b>	+54	<b>82</b>	+63	<b>97</b>	+65	<b>99</b>	+68	<b>102</b>	+77	<b>116</b>	+80	<b>119</b>	+84	<b>123</b>
	<b>43</b>		<b>51</b>		<b>54</b>		<b>63</b>		<b>65</b>		<b>68</b>		<b>77</b>		<b>80</b>		<b>84</b>
+73	<b>88</b>	+86	<b>106</b>	+89	<b>109</b>	+103	<b>128</b>	+105	<b>130</b>	+108	<b>133</b>	+123	<b>153</b>	+126	<b>156</b>	+130	<b>160</b>
+43	<b>73</b>	+51	<b>87</b>	+54	<b>90</b>	+63	<b>107</b>	+65	<b>109</b>	+68	<b>112</b>	+77	<b>128</b>	+80	<b>131</b>	+84	<b>135</b>
	<b>43</b>		<b>51</b>		<b>54</b>		<b>63</b>		<b>65</b>		<b>68</b>		<b>77</b>		<b>80</b>		<b>84</b>
+78	<b>93</b>	+93	<b>113</b>	+101	<b>121</b>	+117	<b>142</b>	+125	<b>150</b>	+133	<b>158</b>	+151	<b>181</b>	+159	<b>189</b>	+169	<b>199</b>
+59	<b>82</b>	+71	<b>99</b>	+79	<b>107</b>	+92	<b>125</b>	+100	<b>133</b>	+108	<b>141</b>	+122	<b>161</b>	+130	<b>169</b>	+140	<b>179</b>
	<b>59</b>		<b>71</b>		<b>79</b>		<b>92</b>		<b>100</b>		<b>108</b>		<b>122</b>		<b>130</b>		<b>140</b>

# Design of bearing arrangements

## Housing fits

Nominal housing bore diameter in mm							
over incl.	<b>6</b> <b>10</b>		<b>10</b> <b>18</b>		<b>18</b> <b>30</b>		
Deviation of bearing outside diameter in $\mu\text{m}$ (tolerance class Normal)							
$t_{\Delta\text{Dmp}}$	0 -8		0 -8		0 -9		
Housing deviation, fit interference or fit clearance in $\mu\text{m}$							
Clearance fit	<b>E8</b>	+47 +25	25 35 55	+59 +32	32 44 67	+73 +40	40 54 82
	<b>F7</b>	+28 +13	13 21 36	+34 +16	16 25 42	+41 +20	20 30 50
	<b>G6</b>	+14 +5	5 11 22	+17 +6	6 12 25	+20 +7	7 14 29
	<b>G7</b>	+20 +5	5 13 28	+24 +6	6 15 32	+28 +7	7 17 37
	<b>H6</b>	+9 0	<b>0</b> 6 17	+11 0	<b>0</b> 6 19	+13 0	<b>0</b> 7 22
	<b>H7</b>	+15 0	<b>0</b> 8 23	+18 0	<b>0</b> 9 26	+21 0	<b>0</b> 10 30
	<b>H8</b>	+22 0	<b>0</b> 10 30	+27 0	<b>0</b> 12 35	+33 0	<b>0</b> 14 42
	Transition fit	<b>J6</b>	+5 -4	<b>4</b> 2 13	+6 -5	<b>5</b> 1 14	+8 -5
<b>J7</b>		+8 -7	<b>7</b> 1 16	+10 -8	<b>8</b> 1 18	+12 -9	<b>9</b> 1 21
<b>JS6</b>		+4,5 -4,5	<b>4,5</b> 2 12,5	+5,5 -5,5	<b>5,5</b> 1 13,5	+6,5 -6,5	<b>6,5</b> <b>0</b> 15,5
<b>JS7</b>		+7,5 -7,5	<b>7,5</b> 1 15,5	+9 -9	<b>9</b> <b>0</b> 17	+10,5 -10,5	<b>10,5</b> <b>1</b> 19,5
<b>K6</b>		+2 -7	<b>7</b> <b>1</b> 10	+2 -9	<b>9</b> <b>3</b> 10	+2 -11	<b>11</b> <b>4</b> 11
<b>K7</b>		+5 -10	<b>10</b> <b>2</b> 13	+6 -12	<b>12</b> <b>3</b> 14	+6 -15	<b>15</b> <b>5</b> 15

Example: housing  $\varnothing 100 \text{ K6 } \textcircled{\text{C}}$

Minimum material value	+4	<b>18</b>	Interference or fit clearance if the maximum material values are combined. Probable interference or fit clearance.
Maximum material value	-18	<b>6</b> 19	
Interference or fit clearance if minimum material values are combined. Values <b>in bold type</b> in the group of three indicate fit interference, values in normal type indicate fit clearance.			



<b>30</b>		<b>50</b>		<b>80</b>		<b>120</b>		<b>150</b>	
<b>50</b>		<b>80</b>		<b>120</b>		<b>150</b>		<b>180</b>	
0		0		0		0		0	
-11		-13		-15		-18		-25	
+89	50	+106	60	+126	72	+148	85	+148	85
+50	67	+60	79	+72	85	+85	112	+85	114
	100		119		141		166		173
+50	25	+60	30	+71	36	+83	43	+83	43
+25	37	+30	44	+36	53	+43	62	+43	64
	61		73		86		101		108
+25	9	+29	10	+34	12	+39	14	+39	14
+9	18	+10	21	+12	24	+14	28	+14	31
	36		42		49		57		64
+34	9	+40	10	+47	12	+54	14	+54	14
+9	21	+10	24	+12	29	+14	33	+14	36
	45		53		62		72		79
+16	<b>0</b>	+19	<b>0</b>	+22	<b>0</b>	+25	<b>0</b>	+25	<b>0</b>
0	9	0	11	0	12	0	14	0	17
	27		32		37		43		50
+25	<b>0</b>	+30	<b>0</b>	+35	<b>0</b>	+40	<b>0</b>	+40	<b>0</b>
0	12	0	14	0	17	0	19	0	22
	36		43		50		58		65
+39	<b>0</b>	+46	<b>0</b>	+54	<b>0</b>	+63	<b>0</b>	+63	<b>0</b>
0	17	0	20	0	23	0	27	0	29
	50		59		69		81		88
+10	<b>6</b>	+13	<b>6</b>	+16	<b>6</b>	+18	<b>7</b>	+18	<b>7</b>
-6	3	-6	5	-6	6	-7	7	-7	10
	21		26		31		36		43
+14	<b>11</b>	+18	<b>12</b>	+22	<b>13</b>	+26	<b>14</b>	+26	<b>14</b>
-11	1	-12	2	-13	4	-14	5	-14	8
	25		31		37		44		51
+8	<b>8</b>	+9,5	<b>9,5</b>	+11	<b>11</b>	+12,5	<b>12,5</b>	+12,5	<b>12,5</b>
-8	1	-9,5	<b>0</b>	-11	1	-12,5	1	-12,5	3
	19		22,5		26		30,5		37,5
+12,5	<b>12,5</b>	+15	<b>15</b>	+17,5	<b>17,5</b>	+20	<b>20</b>	+20	<b>20</b>
-12,5	1	-15	1	-17,5	1	-20	1	-20	1
	23,5		28		32,5		38		45
+3	<b>13</b>	+4	<b>15</b>	+4	<b>18</b>	+4	<b>21</b>	+4	<b>21</b>
-13	4	-15	4	-18	6	-21	7	-21	4
	14		17		19		22		29
+7	<b>18</b>	+9	<b>21</b>	+10	<b>25</b>	+12	<b>28</b>	+12	<b>28</b>
-18	6	-21	7	-25	8	-28	9	-28	6
	18		22		25		30		37

# Design of bearing arrangements

## Housing fits (continued)

Nominal housing bore diameter in mm							
over incl.	<b>180</b> <b>250</b>		<b>250</b> <b>315</b>		<b>315</b> <b>400</b>		
Deviation of bearing outside diameter in $\mu\text{m}$ (tolerance class Normal)							
$t_{\Delta\text{Dmp}}$	0 -30		0 -35		0 -40		
Housing deviation, fit interference or fit clearance in $\mu\text{m}$							
Clearance fit	<b>E8</b>	+172 +100	100 134 202	+191 +110	110 149 226	+214 +125	125 168 254
	<b>F7</b>	+96 +50	50 75 126	+108 +56	56 85 143	+119 +62	62 94 159
	<b>G6</b>	+44 +15	15 35 74	+49 +17	17 39 84	+54 +18	18 43 94
	<b>G7</b>	+61 +15	15 40 91	+69 +17	17 46 104	+75 +18	18 50 115
	<b>H6</b>	+29 0	<b>0</b> 20 59	+32 0	<b>0</b> 22 67	+36 0	<b>0</b> 25 76
	<b>H7</b>	+46 0	<b>0</b> 25 76	+52 0	<b>0</b> 29 87	+57 0	<b>0</b> 32 97
	<b>H8</b>	+72 0	<b>0</b> 34 102	+81 0	<b>0</b> 39 116	+89 0	<b>0</b> 43 129
	Transition fit	<b>J6</b>	+22 -7	<b>7</b> 13 52	+25 -7	<b>7</b> 15 60	+29 -7
<b>J7</b>		+30 -16	<b>16</b> 9 60	+36 -16	<b>16</b> 13 71	+39 -18	<b>18</b> 14 79
<b>JS6</b>		+14,5 -14,5	<b>14,5</b> 5 44,5	+16 -16	<b>16</b> 7 51	+18 -18	<b>18</b> 6 58
<b>JS7</b>		+23 -23	<b>23</b> 2 53	+26 -26	<b>26</b> 3 61	+28,5 -28,5	<b>28,5</b> 3 68,5
<b>K6</b>		+5 -24	<b>24</b> <b>4</b> 35	+5 -27	<b>27</b> <b>5</b> 40	+7 -29	<b>29</b> <b>4</b> 47
<b>K7</b>		+13 -33	<b>33</b> <b>8</b> 43	+16 -36	<b>36</b> <b>7</b> 51	+17 -40	<b>40</b> <b>8</b> 57

Values in **bold type** in the group of three indicate fit interference, values in normal type indicate fit clearance.





<b>400 500</b>		<b>500 630</b>		<b>630 800</b>		<b>800 1000</b>		<b>1000 1250</b>	
0 -45		0 -50		0 -75		0 -100		0 -125	
+232 +135	135 182 277	+255 +145	145 199 305	+285 +160	160 227 360	+310 +170	170 250 410	+360 +195	195 292 485
+131 +68	68 104 176	+146 +76	76 116 196	+160 +80	80 132 235	+176 +86	86 149 276	+203 +98	98 175 328
+60 +20	20 48 105	+66 +22	22 54 116	+74 +24	24 66 149	+82 +26	26 78 182	+94 +28	28 93 219
+83 +20	20 56 128	+92 +22	22 62 142	+104 +24	24 76 179	+116 +26	26 89 216	+133 +28	28 105 258
+40 0	0 28 85	+44 0	0 32 94	+50 0	0 42 125	+56 0	0 52 156	+66 0	0 64 191
+63 0	0 36 108	+70 0	0 40 120	+80 0	0 52 155	+90 0	0 63 190	+105 0	0 77 230
+97 0	0 47 142	+110 0	0 54 160	+125 0	0 67 200	+140 0	0 80 240	+165 0	0 97 290
+33 -7	7 21 78	-	-	-	-	-	-	-	-
+43 -20	20 16 88	-	-	-	-	-	-	-	-
+20 -20	20 8 65	+22 -22	22 10 72	+25 -25	25 17 100	+28 -28	28 24 128	+33 -33	33 31 158
+31,5 -31,5	31,5 4 76,5	+35 -35	35 5 85	+40 -40	40 12 115	+45 -45	45 18 145	+52,5 -52,5	52 24 177
+8 -32	32 4 53	0 -44	44 12 50	0 -50	50 8 75	0 -56	56 4 100	0 -66	66 2 125
+18 -45	45 9 63	0 -70	70 30 50	0 -80	80 28 75	0 -90	90 27 100	0 -105	105 28 125

# Design of bearing arrangements

## Housing fits (continued)

Nominal housing bore diameter in mm							
over incl.	<b>6</b> <b>10</b>	<b>10</b> <b>18</b>	<b>18</b> <b>30</b>				
Deviation of bearing outside diameter in $\mu\text{m}$ (tolerance class Normal)							
$t_{\Delta D_{mp}}$	0 -8	0 -8	0 -9				
Housing deviation, fit interference or fit clearance in $\mu\text{m}$							
Transition fit	<b>M6</b>	-3 -12	<b>12</b> <b>6</b> 5	-4 -15	<b>15</b> <b>9</b> 4	-4 -17	<b>17</b> <b>10</b> 5
	<b>M7</b>	0 -15	<b>15</b> <b>7</b> 8	0 -18	<b>18</b> <b>9</b> 8	0 -21	<b>21</b> <b>11</b> 9
	<b>N6</b>	-7 -16	<b>16</b> <b>10</b> 1	-9 -20	<b>20</b> <b>14</b> 1	-11 -24	<b>24</b> <b>17</b> 2
	<b>N7</b>	-4 -19	<b>19</b> <b>11</b> 4	-5 -23	<b>23</b> <b>14</b> 3	-7 -28	<b>28</b> <b>18</b> 2
Interference fit	<b>P6</b>	-12 -21	<b>21</b> <b>15</b> <b>4</b>	-15 -26	<b>26</b> <b>20</b> <b>7</b>	-18 -31	<b>31</b> <b>24</b> <b>9</b>
	<b>P7</b>	-9 -24	<b>24</b> <b>16</b> <b>1</b>	-11 -29	<b>29</b> <b>20</b> <b>3</b>	-14 -35	<b>35</b> <b>25</b> <b>5</b>

Values **in bold type** in the group of three indicate fit interference, values in normal type indicate fit clearance.



<b>30</b>		<b>50</b>		<b>80</b>		<b>120</b>		<b>150</b>	
<b>50</b>		<b>80</b>		<b>120</b>		<b>150</b>		<b>180</b>	
0		0		0		0		0	
-11		-13		-15		-18		-25	
-4	<b>20</b>	-5	<b>24</b>	-6	<b>28</b>	-8	<b>33</b>	-8	<b>33</b>
-20	<b>11</b>	-24	<b>13</b>	-28	<b>16</b>	-33	<b>19</b>	-33	<b>16</b>
	7		8		9		10		17
0	<b>25</b>	0	<b>30</b>	0	<b>35</b>	0	<b>40</b>	0	<b>40</b>
-25	<b>13</b>	-30	<b>16</b>	-35	<b>18</b>	-40	<b>21</b>	-40	<b>18</b>
	11		13		15		18		25
-12	<b>28</b>	-14	<b>33</b>	-16	<b>38</b>	-20	<b>45</b>	-20	<b>45</b>
-28	<b>19</b>	-33	<b>22</b>	-38	<b>26</b>	-45	<b>31</b>	-45	<b>28</b>
	1		1		1		2		5
-8	<b>33</b>	-9	<b>39</b>	-10	<b>45</b>	-12	<b>52</b>	-12	<b>52</b>
-33	<b>21</b>	-39	<b>25</b>	-45	<b>28</b>	-52	<b>33</b>	-52	<b>30</b>
	3		4		5		3		13
-21	<b>37</b>	-26	<b>45</b>	-30	<b>52</b>	-36	<b>61</b>	-36	<b>61</b>
-37	<b>28</b>	-45	<b>34</b>	-52	<b>40</b>	-61	<b>47</b>	-61	<b>44</b>
	10		13		15		18		11
-17	<b>42</b>	-21	<b>51</b>	-24	<b>59</b>	-28	<b>68</b>	-28	<b>68</b>
-42	<b>30</b>	-51	<b>37</b>	-59	<b>42</b>	-68	<b>49</b>	-68	<b>46</b>
	6		8		9		10		3

# Design of bearing arrangements

## Housing fits (continued)

Nominal housing bore diameter in mm							
over incl.	<b>180</b> <b>250</b>	<b>250</b> <b>315</b>	<b>315</b> <b>400</b>				
Deviation of bearing outside diameter in $\mu\text{m}$ (tolerance class Normal)							
$t_{\Delta Dmp}$	0 -30	0 -35	0 -40				
Housing deviation, fit interference or fit clearance in $\mu\text{m}$							
Transition fit	<b>M6</b>	-8	<b>37</b>	-9	<b>41</b>	-10	<b>46</b>
		-37	<b>17</b> 22	-41	<b>19</b> 26	-46	<b>21</b> 30
	<b>M7</b>	0	<b>46</b>	0	<b>52</b>	0	<b>57</b>
		-46	<b>21</b> 30	-52	<b>23</b> 35	-57	<b>25</b> 40
<b>N6</b>	-22	<b>51</b>	-25	<b>57</b>	-26	<b>62</b>	
	-51	<b>31</b> 8	-57	<b>35</b> 10	-62	<b>37</b> 14	
<b>N7</b>	-14	<b>60</b>	-14	<b>66</b>	-16	<b>73</b>	
	-60	<b>35</b> 16	-66	<b>37</b> 21	-73	<b>41</b> 24	
Interference fit	<b>P6</b>	-41	<b>70</b>	-47	<b>79</b>	-51	<b>87</b>
		-70	<b>50</b> 11	-79	<b>57</b> 12	-87	<b>62</b> 11
<b>P7</b>	-33	<b>79</b>	-36	<b>88</b>	-41	<b>98</b>	
	-79	<b>54</b> 3	-88	<b>59</b> 1	-98	<b>66</b> 1	

Values in **bold type** in the group of three indicate fit interference, values in normal type indicate fit clearance.



<b>400</b>		<b>500</b>		<b>630</b>		<b>800</b>		<b>1000</b>	
<b>500</b>		<b>630</b>		<b>800</b>		<b>1000</b>		<b>1250</b>	
0		0		0		0		0	
-45		-50		-75		-100		-125	
-10	<b>50</b>	-26	<b>70</b>	-30	<b>80</b>	-34	<b>90</b>	-40	<b>106</b>
-50	<b>22</b>	-70	<b>38</b>	-80	<b>38</b>	-90	<b>38</b>	-106	<b>45</b>
	35		24		45		66		85
0	<b>63</b>	-26	<b>96</b>	-30	<b>110</b>	-34	<b>124</b>	-40	<b>145</b>
-63	<b>27</b>	-96	<b>56</b>	-110	<b>58</b>	-124	<b>61</b>	-145	<b>68</b>
	45		24		45		66		85
-27	<b>67</b>	-44	<b>88</b>	-50	<b>100</b>	-56	<b>112</b>	-66	<b>132</b>
-67	<b>39</b>	-88	<b>56</b>	-100	<b>58</b>	-112	<b>60</b>	-132	<b>67</b>
	18		6		25		44		59
-17	<b>80</b>	-44	<b>114</b>	-50	<b>130</b>	-56	<b>146</b>	-66	<b>171</b>
-80	<b>44</b>	-114	<b>74</b>	-130	<b>78</b>	-146	<b>83</b>	-171	<b>94</b>
	28		6		25		44		59
-55	<b>95</b>	-78	<b>122</b>	-88	<b>138</b>	-100	<b>156</b>	-120	<b>186</b>
-95	<b>67</b>	-122	<b>90</b>	-138	<b>96</b>	-156	<b>104</b>	-186	<b>121</b>
	10		28		13		0		5
-45	<b>108</b>	-78	<b>148</b>	-88	<b>168</b>	-100	<b>190</b>	-120	<b>225</b>
-108	<b>72</b>	-148	<b>108</b>	-168	<b>126</b>	-190	<b>127</b>	-225	<b>148</b>
	0		28		13		0		5

# Design of bearing arrangements

## Geometrical and positional tolerances of bearing seating surfaces

In order to achieve the required fit, the bearing seats and fit surfaces of the shaft and housing bore must conform to certain tolerances, *Figure 2* and table, page 117.

The positional tolerances  $t_4$  for a second bearing seat on the shaft ( $d_2$ ) or in the housing ( $D_2$ ) are dependent on the types of bearings used and the operating conditions. Values for the tolerances  $t_4$  can be requested from Schaeffler.

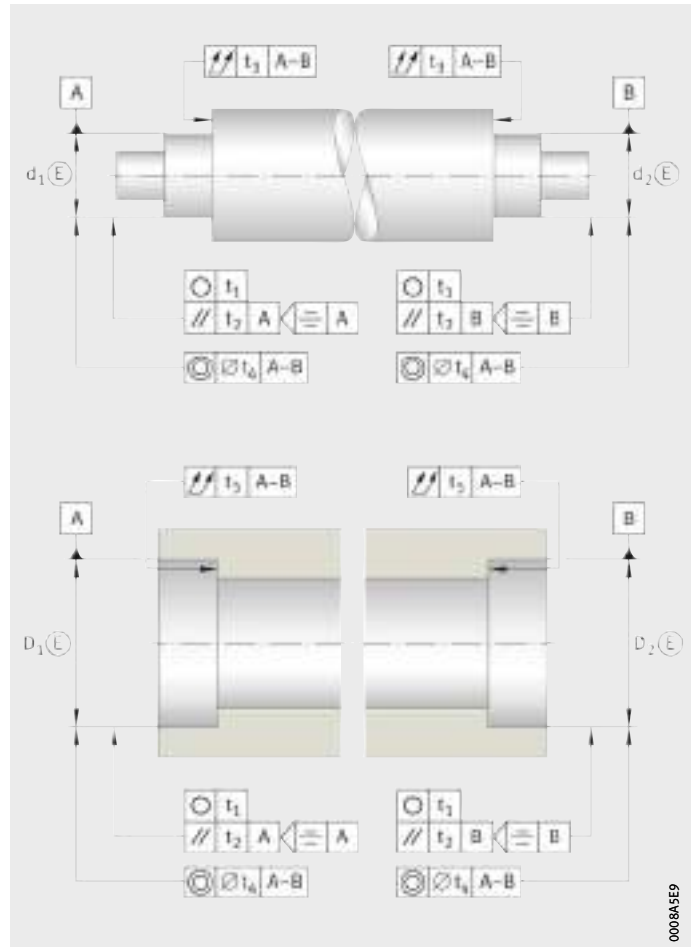

*Figure 2*  
Guide values for geometrical and positional tolerances



## Accuracy of bearing seating surfaces

The degree of accuracy for the bearing seat tolerances on the shaft and in the housing correspond to the fundamental tolerances in accordance with ISO 286-1, see table.



When using the fits in accordance with ISO 286-1, the envelope requirement  $\textcircled{E}$  always applies.

## Geometrical and positional tolerances of bearing seating surfaces

Bearing tolerance class		Bearing seating surface	Fundamental tolerance grades <sup>1)</sup>				
ISO 492	DIN 620		Diameter tolerance	Roundness tolerance	Parallelism tolerance	Total axial runout tolerance of abutment shoulder	
				$t_1$	$t_2$	$t_3$	
Normal 6X	PN (P0) P6X	Shaft	IT6 (IT5)	Circumferential load IT4/2	IT4/2	IT4	
				Point load IT5/2			IT5/2
		Housing	IT7 (IT6)	Circumferential load IT5/2	IT5/2		IT5
				Point load IT6/2			
5	P5	Shaft	IT5	Circumferential load IT2/2	IT2/2	IT2	
				Point load IT3/2			IT3/2
		Housing	IT6	Circumferential load IT3/2	IT3/2		IT3
				Point load IT4/2			
4	P4 P4S <sup>2)</sup> SP <sup>2)</sup>	Shaft	IT4	Circumferential load IT1/2	IT1/2	IT1	
				Point load IT2/2			IT2/2
		Housing	IT5	Circumferential load IT2/2	IT2/2		IT2
				Point load IT3/2			
	UP <sup>2)</sup>	Shaft	IT3	Circumferential load IT0/2	IT0/2	IT0	
				Point load IT1/2			IT1/2
		Housing	IT4	Circumferential load IT1/2	IT1/2		IT1
				Point load IT2/2			

<sup>1)</sup> ISO fundamental tolerances (IT grades) in accordance with ISO 286:

<sup>2)</sup> Not included in DIN 620.

# Design of bearing arrangements

## Roughness of bearing seats

The roughness of the bearing seats must be matched to the tolerance class of the bearings. The mean roughness value Ra must not be too high, in order to maintain the interference loss within limits. Shafts should be ground and bores should be precision turned, see table.

The bore and shaft tolerances and permissible roughness values are also given in the design and safety guidelines in the product sections.

## Guide values for roughness of bearing seating surfaces

Diameter of bearing seat d (D) mm		Recommended mean roughness values Ra and roughness classes for ground bearing seats Diameter tolerance corresponding to <sup>1)</sup>			
over	incl.	IT7	IT6	IT5	IT4
–	80	1,6 (N7)	0,8 (N6)	0,4 (N5)	0,2 (N4)
80	500	1,6 (N7)	1,6 (N7)	0,8 (N6)	0,4 (N5)

<sup>1)</sup> The values in brackets are roughness classes in accordance with DIN EN ISO 1302.





# Sealing

**Functions** A basic distinction is made between contact and non-contact seals in the adjacent construction and the bearing.

The sealing arrangement has a considerable influence on the operating life of a bearing arrangement. Its function is to retain the lubricant in the bearing and prevent the ingress of contaminants into the bearing.

Contaminants may have various effects:

- A large quantity of very small, abrasive particles causes wear in the bearing. The increase in clearance or noise bring the operating life of the bearing to an end.
- Large, overrolled hard particles reduce the fatigue life since pittings occur at the indentation points under high bearing loads.

## Overview of seal types

Seals for radial insert ball bearings are of a three-piece design. This concept offers, due to the rigidly rolled-in sheet steel washer, optimum seating in the bearing as well as concentric alignment of the seal lip to the inner ring.

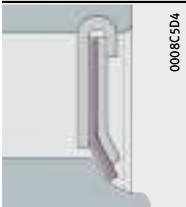
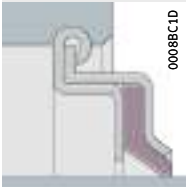
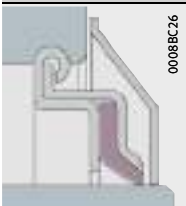

Seals for radial insert ball bearings are available in various designs, see table. The stated suffix is included in the ordering designation and explained in the table of suffixes.

### Seal types

<b>P seal (NPP)</b>	
	<p style="text-align: center; font-size: small;">0008C5D4</p> <p>Two zinc-coated sheet steel washers with intermediate NBR part, seal lip axially preloaded.</p> <p>In order to protect the seal lip from mechanical damage, the outer sheet steel washer extends a considerable distance down towards the bearing inner ring.</p> <p>For use in narrow radial insert ball bearings with inner ring extended on one side.</p>
<b>R seal (KRR)</b>	
	<p style="text-align: center; font-size: small;">0008BC1D</p> <p>Two zinc-coated sheet steel washers extended outwards and angled downwards with intermediate NBR or PTFE part and radially preloaded seal lip. Improved protection against mechanical damage.</p> <p>Substantial grease reservoir due to the space between the extended and angled sheet steel washers. Used in radial insert ball bearings with inner ring extended on both sides.</p>
<b>R seal with flinger shield (KRR...-2C)</b>	
	<p style="text-align: center; font-size: small;">0008BC26</p> <p>As R seal, but with outer flinger shield with anti-corrosion protection.</p> <p>Additional sealing action without restriction on speed and with additional protection against mechanical damage.</p>

# Sealing

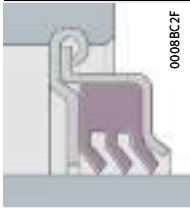
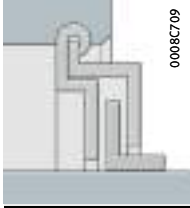
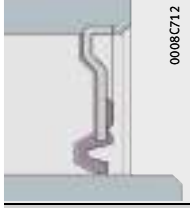
## Seal types (continued)

<b>T seal (KTT)</b>	
	<p>0008C2F</p> <p>Two zinc-coated sheet steel washers with intermediate NBR part and three radially preloaded seal lips for heavily contaminated conditions. For better protection of the seal lip against mechanical damage, the outer sheet steel washer is angled outwards.</p> <p>Lower speeds due to higher friction.</p>
<b>L seal (labyrinth seal) (KLL)</b>	
	<p>0008C709</p> <p>Two zinc-coated sheet steel washers extended outwards in the outer ring with a zinc-plated intermediate sheet steel L-section ring pressed onto the inner ring.</p> <p>Substantial grease reservoir due to the space between the extended and angled sheet steel washers.</p> <p>For use in bearings with inner ring extended on both sides. For increased temperatures and lower friction.</p>
<b>RSR seal (2RSR)</b>	
	<p>0008C712</p> <p>Single piece, zinc-plated sheet steel washer with vulcanised and radially preloaded seal lip made from NBR.</p> <p>For use in radial insert ball bearings with integral adapter sleeve.</p>
<b>Sealing cartridge with flinger shield</b>	
	<p>0008C38</p> <p>Design identical to normal cartridge seal but supplemented by a flinger shield to protect the bearing against high pressure cleaning equipment and mechanical damage.</p>
<b>Combined sealing washer and flinger shield with protective shield</b>	
	<p>0008C41</p> <p>Design identical to normal sealing washer and flinger shield but supplemented by a protective shield to protect the bearing against high pressure cleaning equipment and mechanical damage.</p>



**BRS seals** Bearings with BRS seals can be supplied by agreement, *Figure 1*. The friction in this case is as low as that in bearings with sealing shields. They have the advantage over these, however, that the outer elastic rim gives good sealing when fitted in the slot in the outer ring. This is important with a rotating outer ring since the base oil is separated from the soap suspension by centrifugal force and would escape through the unsealed metallic seat in the outer ring if sealing shields were fitted.

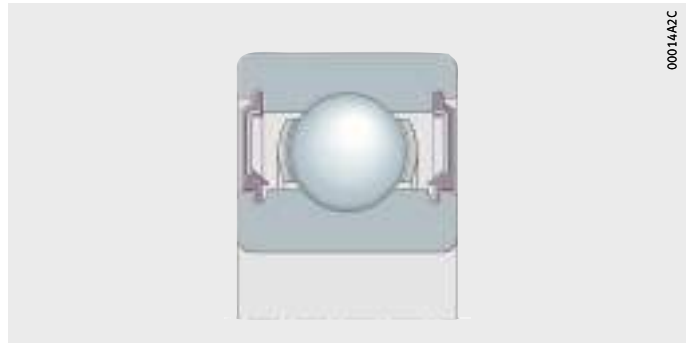

*Figure 1*  
BRS seals

**Non-contact seals  
in the adjacent construction**

With non-contact seals, only lubricant friction occurs in the lubrication gap. The seals do not undergo wear and remain capable of operation for a long period. Since they generate no heat, non-contact seals are also suitable for very high speeds.

# Mounting and dismounting

Radial insert ball bearings must be handled with care before and during mounting. Their trouble-free operation is also dependent on the care taken during mounting.

## Handling and use

Rolling bearings, rolling bearing parts and Arcanol rolling bearing greases are high quality goods and must therefore be handled with care.

## Storage of rolling bearings

The performance capability of modern rolling bearings lies at the boundaries of what is technically achievable. The materials, dimensional and geometrical tolerances, surface quality and lubrication have been optimised for maximum levels of function, which means that even slight deviations in functional areas, such as those caused by corrosion, can impair the performance capacity. In order to realise the full performance capability of rolling bearings, it is essential to match the anti-corrosion protection, packaging, storage and handling to each other.

Anti-corrosion protection and packaging constitute part of the bearing and are optimised such that they preserve all characteristics of the product at the same time as far as possible. In addition to protecting the surface against corrosion, this includes emergency running lubrication, friction, lubricant compatibility, noise behaviour, resistance to ageing and compatibility with rolling bearing components (cage and seal material).

Since the packaging offers additional protection against contamination through dirt, foreign media and other environmental influences, we recommend that the components should not be unpacked until immediately prior to further processing.



### Storage conditions for rolling bearings



As a basic prerequisite, parts must be stored in a closed storage area which cannot be affected by any aggressive media, such as exhaust gases from vehicles or gases, mist or aerosols of acids, lyes or salts. Direct sunlight should be avoided since, apart from the harmful effects of UV radiation, it can lead to wide temperature fluctuations in the packaging. The temperature should be constant and air humidity should be as low as possible. Jumps in temperature and increased humidity lead to condensation.

The following conditions must be fulfilled:

- frost-free storage, i.e. a temperature  $> +5\text{ °C}$   
(this prevents formation of white frost, up to a maximum of  $+2\text{ °C}$  permissible up to 12 hours per day)
- maximum temperature  $+40\text{ °C}$   
(to prevent excessive drainage of anti-corrosion oils)
- relative humidity  $< 65\%$   
(with temperature changes up to 70% up to a maximum of 12 hours per day).

The temperature and humidity must be continuously monitored. This can be carried out using a datalogger. The measurements must be taken at intervals of no more than 2 hours.

At least 2 measurement points must be selected: the highest point and the lowest point in the vicinity of an external wall at which the goods can be stored.

### Storage periods for rolling bearings

Empirical values show that corrosion protection is usually achieved for 3 years. In particular, greased rolling bearings should not be stored for longer, since the chemical-physical behaviour of greases may change during storage. Even if the minimum performance capacity remains, the safety reserves of the grease may have diminished. This also applies to greased bearings with sealing shields or washers.

In principle, rolling bearings can also be used beyond the storage period of 3 years. If this period is exceeded, an agreement must be reached with the lubricant manufacturer. The storage periods stated are empirical values based on practice. This is therefore not associated with any extension in the legal or contractually agreed warranty periods. Furthermore, these empirical values only relate to the component in its unopened original packaging.

If these periods are exceeded, it is recommended that the bearing should be checked for corrosion, the condition of the anti-corrosion oil, the lubricating grease and the plastic and elastomer components before it is used.

# Mounting and dismounting

## Storage of Arcanol rolling bearing greases

The information on storage of rolling bearings applies as appropriate to Arcanol rolling bearing greases. The precondition is that the grease is stored in closed, completely filled original containers.

## Storage periods for Arcanol rolling bearing greases

Rolling bearing greases are mixtures of oil, thickener and additives. Such mixtures of liquid and solid substances do not have unlimited stability. During storage, their chemical-physical characteristics may change and they should therefore be used up as soon as possible.

If the storage conditions are observed, Arcanol greases can be stored without loss of performance for 3 years. As in the case of rolling bearings, however, the permissible storage period should not be seen as a rigid limit.

If storage is carried out as prescribed, most greases can also be used after 3 years, if allowances are made for small changes. If there is any doubt when using older greases, random sample checking of chemical-physical characteristics is recommended in order to determine any changes in the grease. It is therefore not possible to state storage periods for containers that have been opened. If containers are to be stored after opening, the grease surface should always be brushed flat, the container should be sealed airtight and it should be stored such that the empty space is upwards. High temperatures should be avoided in all cases.

## Unpacking of rolling bearings

Perspiration leads to corrosion. Hands should be kept clean and dry and protective gloves worn if necessary. Bearings should only be removed from their original packaging immediately before assembly. If bearings are removed from multi-item packaging with dry preservation, the package must be closed again immediately, since the protective vapour phase is only effective in closed packaging. Bearings should be oiled or greased immediately after unpacking.

## Compatibility, miscibility

The anti-corrosion agents in bearings with an oil-based preservative are compatible and miscible with oils and greases having a mineral oil base. Compatibility should be checked if synthetic lubricants or thickeners other than lithium or lithium complex soaps are used. If there is an incompatibility, the anti-corrosion oil should be washed out before greasing, especially in the case of lubricants with a PTFE/alkoxyfluoroether base and thickeners based on polycarbamide. Bearings should be washed out if the lubricant is changed or the bearings are contaminated. If in doubt, please contact the relevant lubricant manufacturer.



## Cleaning of rolling bearings

The following are suitable for degreasing and washing of rolling bearings:

- aqueous neutral, acidic or alkaline cleaning agents. Check the compatibility of alkaline agents with aluminum components before cleaning
- organic cleaning agents such as paraffin oil free from water and acid, petroleum ether (not petrol), spirit, dewatering fluids, freon 12 substitutes, cleaning agents containing chlorinated hydrocarbons.

Cleaning should be carried out using brushes, paint brushes or lint-free cloths. In the case of resinous oil or grease residues, precleaning by mechanical means followed by treatment with an aqueous, strongly alkaline cleaning agent is recommended.



Legal regulations relating to handling, environmental protection and health and safety at work must be observed. The specifications of cleaning agent manufacturers must be observed.

Paraffin oil, petroleum ether, spirit and dewatering fluids are flammable, alkaline agents are corrosive. The use of chlorinated hydrocarbons is associated with the risk of fire, explosion and decomposition as well as with health hazards. These hazards and appropriate protective measures are described comprehensively in ZH1/425 of the German Federation of Institutions for Statutory Accident Insurance and Prevention (Hauptverband der gewerblichen Berufsgenossenschaften).

After cleaning, rolling bearings must be dried and preservative applied immediately (risk of corrosion).

# Mounting and dismounting

## General guidelines for mounting

The following guidelines must always be taken into account:

- The assembly area must be kept clean and free from dust.
- Protect bearings from dust, contaminants and moisture. Contaminants have a detrimental influence on the running and operating life of rolling bearings.
- Before mounting work is started, familiarise yourself with the design by means of the final assembly drawing.
- Before mounting, check whether the bearing presented for mounting corresponds to the data in the drawing.
- Check the housing bore and shaft seat for dimensional, geometrical and positional accuracy as well as cleanliness.
- Check that the shaft and housing bore have a lead chamfer of 10° to 15°.
- Wipe away any anti-corrosion agent from the seating and contact surfaces, wash anti-corrosion agent out of tapered bores.
- Lightly oil the bearing ring seating surfaces or rub with grease.
- Do not cool the bearings excessively. Moisture due to condensation can lead to corrosion in the bearings and bearing seatings.
- After mounting, supply the rolling bearings with lubricant.
- Check the correct functioning of the bearing arrangement.



**Mounting of housing units**

Radial insert ball bearings must be handled with care before and during mounting. Their trouble-free operation is also dependent on the care taken during mounting.

**Delivered condition, INA brand**

The housings have a coating of anthracite grey primer ( $\approx$  RAL 7016). The radial insert ball bearings are greased; for information on the grease used, see the features of the specific bearing. A standard kit is included, see page 238.

**Delivered condition, FAG brand**

The housings have a coating of black primer paint (RAL 9005). The radial insert ball bearings are greased using a grease in grease group GA13, see table, page 68. The housing units are supplied with a loose packed lubrication nipple and integrated end cap for the lubrication nipple as well as an Allen key.

**Storage and shelf life**

The units should be stored:

- in dry, clean rooms with the temperature as constant as possible
- at a relative humidity of max. 65%.

The storage period of radial insert ball bearings is limited by the storage life of the grease, see section Lubrication, page 62.

**Unpacking**

Perspiration causes corrosion. Hands must be kept clean and dry. Bearings should not be removed from their original packaging until immediately before mounting.

# Mounting and dismounting

## Guidelines for mounting of housing units



If flake graphite cast iron housings and bearings are not supplied by INA as ready-to-fit units but are instead combined by the customer, the following guidelines should be followed:

- If the fit is too loose, grease can escape between the housing and bearing and will not therefore reach the bearing during relubrication.
- If the fit is too tight, the bearing outer ring cannot align itself within the housing bore.

The assembly area should be as dry and clean as possible.

First, screw mount the housing on the adjacent construction, then locate the bearing inner ring on the shaft. If this sequence is applied, the bearing aligns itself to the shaft in such a way that no stresses occur.

Ensure that the fitting tools and fixing screws are present.

Clean the shaft and remove any burrs.

Inspect the bearing seating surfaces on the shaft.

Keep bearing seating surfaces clean, dry and free of grease.



The specified tolerances must be observed.

Mounting forces must never be directed through the rolling elements.

Blows should never be applied directly to the bearing rings and seals.

## Mounting of coated components

Before the mounting of products with Corrotect coating, they should be checked for compatibility with the media.

The tolerances are increased by the thickness of the coating.

In order to reduce the forces involved in pressing-in, the surface of the parts should be lightly greased or a mounting paste used.



## Mounting of cast units

Plummer block and flanged housing units have various options for location on the shaft. Housing units of the brand INA can be combined with bearing end caps, see page 134.

### Radial insert ball bearings with eccentric locking collar or grub screw in inner ring

Housing units and radial insert ball bearings with eccentric locking collar or grub screw in inner ring, *Figure 1*:

- ▶ Push the housing unit onto the shaft and align it with the fixing holes in the adjacent construction.
- ▶ Fit dowel pins if necessary.
- ▶ Screw the housing to the adjacent construction by means of the fixing screws.



If the shaft is to be supported by several housing units, tighten the screws finger tight at first, align the shaft and then tighten the screws securely.

#### ASE

- ① Alignment
- ② Position of additional through hole for location of dowel pins in accordance with DIN EN ISO 8752 (in the event of high loads occurring parallel to the mounting surface of housings ASE, P and SP)
- ③ Screw mounting on the adjacent construction

*Figure 1*

Sliding the unit onto the shaft

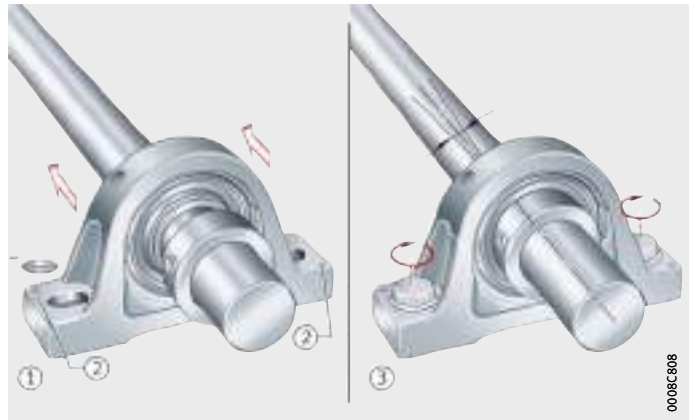

### Location on the shaft by means of eccentric locking collar

- ▶ Slide the eccentric locking collar onto the collar seating on the bearing inner ring and rotate by hand, preferably in the direction of shaft rotation, *Figure 2*.
- ▶ Using a drift and hammer, tension the eccentric locking collar by means of one or two strong blows, *Figure 2*.
- ▶ For location using a locking collar, tighten the grub screw to the tightening torque  $M_A$ , *Figure 3*, page 130.

*Figure 2*

Tensioning the eccentric locking collar

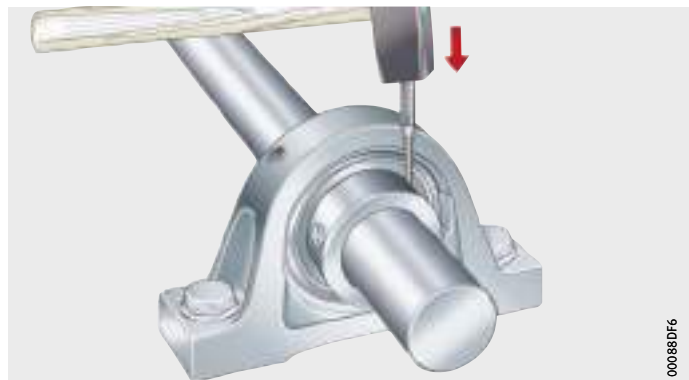

# Mounting and dismounting

**Location on the shaft by means of grub screws in the inner ring**

- ▶ For location using a locking collar, tighten both grub screws to the tightening torque  $M_A$ , see table.

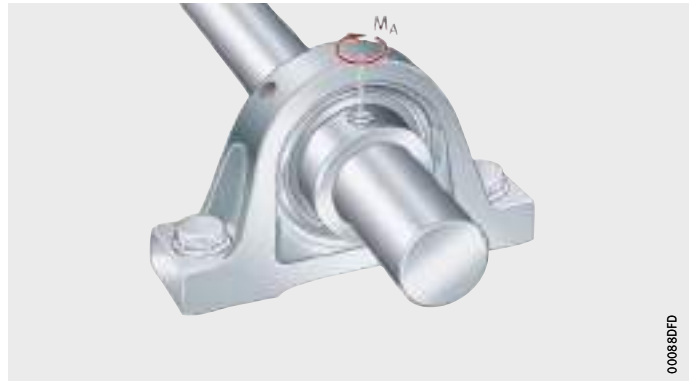

$M_A$  = tightening torque, see table

*Figure 3*

Tightening the grub screw in the eccentric locking collar or inner ring

## Tightening torques for grub screws

Width across flats		Thread		Tightening torques <sup>1)</sup> $M_A$ Nm
W mm	inch	ISO	UNF	
2,5	$\frac{3}{32}$	M5	N10-32	3,6
3	$\frac{1}{8}$	M6×0,75	$\frac{1}{4}$ "-28	6
4	$\frac{5}{32}$	M8×1	$\frac{5}{16}$ "-24	14
5	$\frac{3}{16}$	M10×1,25	$\frac{3}{8}$ "-24	26
6	$\frac{1}{4}$	M12×1,5 M12×1,25 <sup>2)</sup>	$\frac{1}{2}$ "-20	42

<sup>1)</sup> The tightening torques are valid for original INA or FAG grub screws only.

<sup>2)</sup> GYE90-KRR-B.

## Dismounting

Observe the correct sequence in dismounting:

- ▶ For bearings with an eccentric locking collar, undo the grub screw and rotate the locking collar in the opposite direction to the direction of shaft rotation.
- ▶ For bearings with grub screws in the inner ring, undo both grub screws.
- ▶ Unscrew the housing.



## Radial insert ball bearings with adapter sleeve

The bearing seats on the shaft and the outside surface of the adapter sleeve must be dry and free of grease.

- ▶ Slide the housing unit onto the shaft and align it with the fixing holes in the adjacent construction, *Figure 4*.
- ▶ Fit dowel pins if necessary.
- ▶ Screw the housing to the adjacent construction using the fixing screws, *Figure 5*.



If the shaft is to be supported by several housing units, tighten the screws finger tight at first, align the shaft and then tighten the screws securely.

ASE

① Position of additional through hole for location of dowel pins in accordance with DIN EN ISO 8752 (in the event of high loads occurring parallel to the mounting surface of housings ASE, P and SP)



*Figure 4*  
Sliding the unit onto the shaft

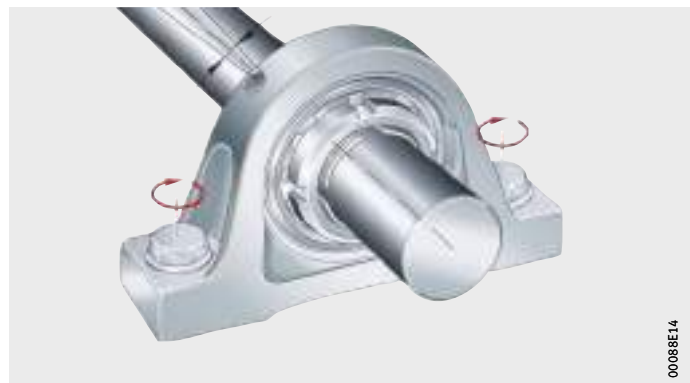

*Figure 5*  
Screw mounting the housing finger tight

# Mounting and dismounting

## Tightening of locknut

► Tighten the locknut using 2 hook wrenches of type A to DIN 1810; during tightening, the adapter sleeve must be held in place using a second hook wrench, *Figure 6*. Wrenches for tightening and holding, see tables.



Do not exceed the maximum tightening torque  $M_A$  given in the table, otherwise the operating clearance in the bearing will become too small. Driving the locknut up will slightly displace the bearing in an axial direction.

The contact pressure at the end face of the inner ring should not exceed  $10 \text{ N/mm}^2$ .



*Figure 6*  
Tightening of locknut

### Hook wrenches and tightening torques for housing units, INA brand

Shaft diameter d mm	Hook wrench, type A, to DIN 1810		Tightening torque Locknut	
	For tightening of locknut	For countertensioning of adapter sleeve	$M_A$	
			min. Nm	max. Nm
20	A 30–32 (HN 4)	A 25–28 (HN 2)	13	17
25	A 40–42 (HN 5)	A 30–32 (HN 3)	22	28
30	A 45–50 (HN 6)	A 34–36 (HN 4)	33	40
35	A 52–55 (HN 7)	A 40–42 (HN 5)	47	56
40	A 58–62 (HN 8)	A 45–50 (HN 6)	70	80
50	A 68–75 (HN 10)	A 52–55 (HN 7)	90	105



**Tightening torques for locknuts,  
Black Series, FAG brand**

Shaft d mm	Locknut	Tightening torques $M_A$ $\pm 5\%$ Nm
20	AN05	25
25	AN06	30
30	AN07	40
35	AN08	50
40	AN09	60
45	AN10	75
50	AN11	100
55	AN12	130
60	AN13	150
65	AN15	170
70	AN16	200
75	AN17	230
80	AN18	270

**Securing of precision locknut**

► Bend the tab on the tab washer into a groove in the locknut to secure the nut against loosening, *Figure 7*.



Ensure that the seal in the bearing is not damaged when bending the locking tab over.

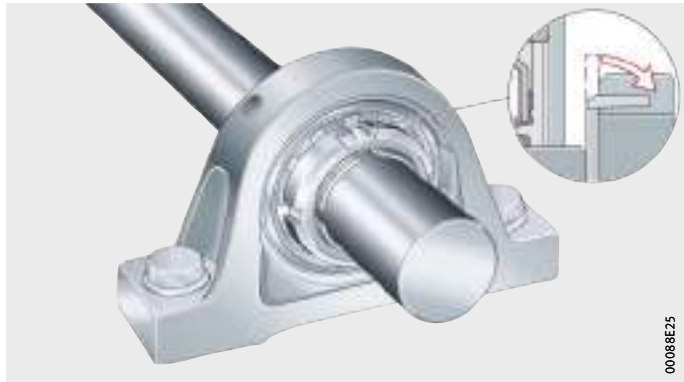

*Figure 7*  
Securing of precision locknut

**Dismounting**

Observe the correct sequence in dismounting:

- Bend back the tab on the tab washer and undo the locknut by a few turns.
- Place the impact cap in front of the locknut and drive the adapter sleeve off the shaft seat using hammer blows.
- Unscrew the housing.

# Mounting and dismounting

## Fitting of bearing end caps



Bearing end caps are available for series of the INA brand.

Bearing end caps should only be fitted or removed while the shaft is stationary. There is a serious danger of injury if the shaft is rotating.

### Fitting

- ▶ Position the tabs of the end cap in the locating slots, noting the position of the INA logo, *Figure 8*.
- ▶ Rotate the end cap clockwise by 90°, noting the position of the INA logo, *Figure 9*. Check that the end cap is secured properly in the housing.

- ① Annular slot
- ② Locating slots

*Figure 8*  
Positioning of end cap

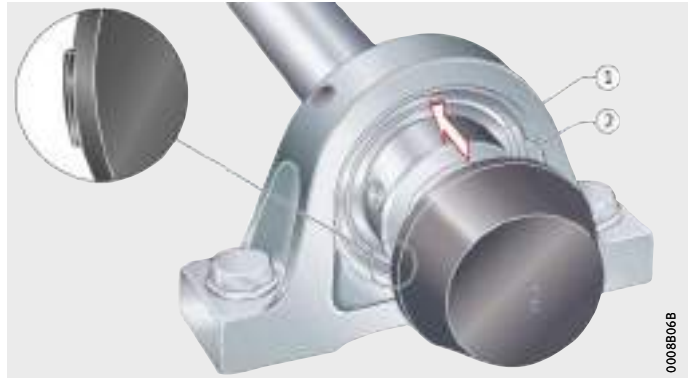

*Figure 9*  
Locating end cap in annular slot

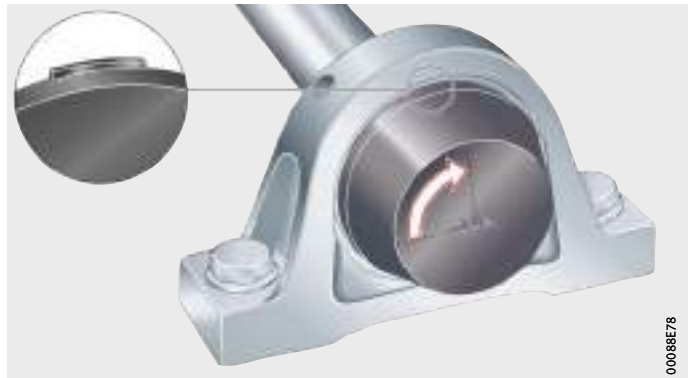





- Removal** Observe the correct sequence in removal:
- ▶ Loosen the end cap by rotating it anticlockwise (90°), noting the position of the INA logo, *Figure 10*.

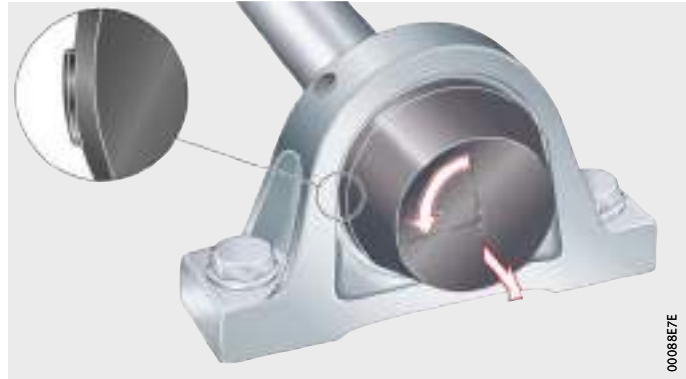

*Figure 10*  
Removal of end cap

# Mounting and dismounting

## Mounting of sheet steel units

Sheet steel units with eccentric locking collar and grub screws in the inner ring:

- ▶ Slide the housing unit onto the shaft and align it with the fixing holes in the adjacent construction, *Figure 11*.
- ▶ Screw the housing to the adjacent construction using the fixing screws, *Figure 12*. If the shaft is to be supported by several housing units, tighten the screws finger tight at first, align the shaft and then tighten the screws securely.



With two-piece housings, the housing and radial insert ball bearing should be assembled first.



*Figure 11*  
Sliding the unit onto the shaft



*Figure 12*  
Screw mounting the housing  
finger tight



### Location on the shaft by means of eccentric locking collar

- ▶ Slide the eccentric locking collar onto the collar seating on the bearing inner ring and rotate by hand, preferably in the direction of shaft rotation.
- ▶ Using a drift and hammer, tension the eccentric locking collar by means of one or two strong blows, *Figure 13*.
- ▶ For location using a locking collar, tighten the grub screw to the tightening torque  $M_A$ , *Figure 14*.



*Figure 13*  
Tensioning  
the eccentric locking collar

### Location on the shaft by means of grub screws in the inner ring



- ▶ For location using grub screws in the inner ring, tighten both grub screws by means of a torque wrench. Observe the tightening torque  $M_A$ , see table, page 130.



$M_A$  = tightening torque, see table, page 130

*Figure 14*  
Tightening the grub screw in the  
eccentric locking collar or inner ring

### Dismounting

- Observe the correct sequence in dismounting:
- ▶ For bearings with an eccentric locking collar, undo the grub screw and rotate the locking collar in the opposite direction to the direction of shaft rotation.
  - ▶ For bearings with grub screws in the inner ring, undo both grub screws.
  - ▶ Unscrew the housing.

# Mounting and dismounting

## Mounting of rolling bearings with cylindrical seats



Avoid applying direct blows to the bearing rings with a hammer.

### Non-separable bearings

In the case of non-separable bearings, apply the mounting forces to the ring with a tight fit, which should also be fitted first, *Figure 15*. If the inner ring of a non-separable bearing will have a tight fit, press the bearing onto the shaft first, *Figure 15*. The bearing together with the shaft is then pushed into the housing (fit clearance).

Tight fit of the inner ring, mount this ring first

*Figure 15*  
Non-separable bearing

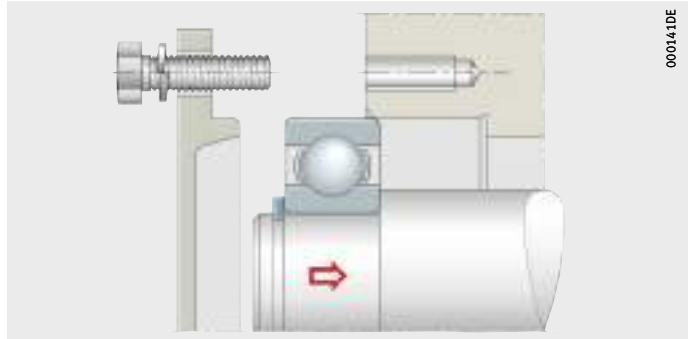

### Cold fitting of bearings by pressing

Bearings up to  $d = 80$  mm can be pressed onto the shaft while cold for normal tight fits, *Figure 16*. Mechanical or hydraulic presses can be used for this purpose.

*Figure 16*  
Mounting using hydraulic press

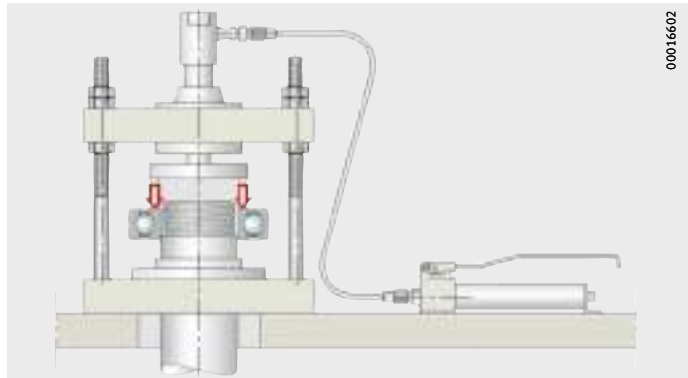



If a press is not available, the bearings can also be driven up by means of a hammer and a mounting sleeve.

In bearings with an angular adjustment facility, tilting of the outer ring is prevented by a mounting disc that is in contact with both bearing rings, *Figure 17*. In bearings with laterally protruding cages or balls, the disc must have a turned recess, *Figure 17*.

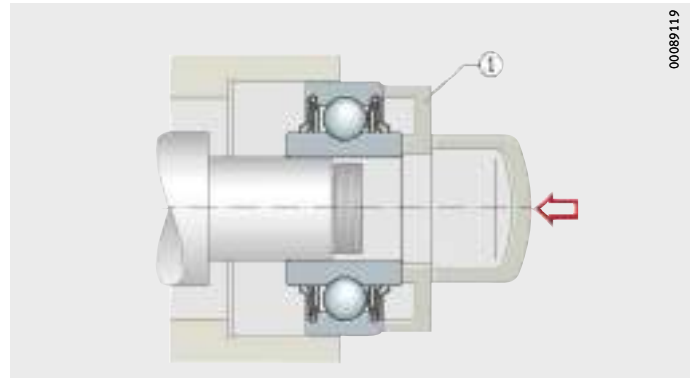

① Mounting disc with turned recess

*Figure 17*  
Mounting using mounting disc

### Heating of bearings

Bearings with a cylindrical bore should be heated before mounting if a tight fit on the shaft is intended and excessive effort is required for pressing by mechanical means, *Figure 18*. The data are valid for maximum fit interference, a room temperature of +20 °C and an excess temperature safety margin of 30 K.

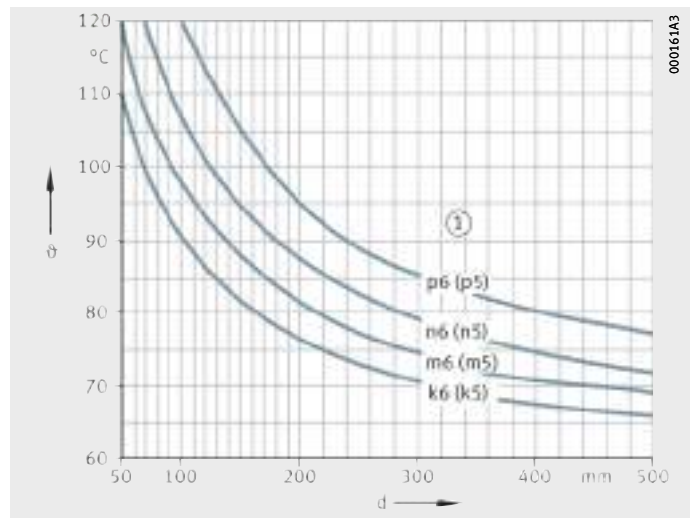

$\vartheta$  = heating temperature  
d = bearing diameter

① Shaft tolerance (this is subject to the envelope requirement ©)

*Figure 18*  
Heating temperature

# Mounting and dismounting

## Induction heating devices

Induction heating devices give rapid, safe and clean heating. The devices are used mainly in volume mounting work.

## Heating plate

Individual bearings can be heated on an electric heating plate. A thermostatic controller must be always be used.

## Heating cabinet

Thermostatically controlled hot air or heating cabinets are safe and clean. This method is mainly used for small and medium sized bearings. The heating times are relatively long.

## Guidelines for dismounting

Information on mounting and dismounting is given in the publications WL 80 100, Mounting of Rolling Bearings and IS 1, Mounting and Maintenance of Rolling Bearings.

Dismounting should be taken into consideration in the original design of the bearing position. If bearing rings are to be mounted with a tight fit, slots should be provided in the shaft or housing bore, for example, to allow removal of the rings.



If the bearing is to be reused, the following guidelines should be taken into consideration:

- Do not use a concentrated or “hard” flame.
- Avoid direct blows on the bearing rings.
- Do not apply fitting forces through the rolling elements.
- Carefully clean the bearings after dismounting.



## Dismounting of rolling bearings on cylindrical seats

If the bearings and adjacent parts are to be reused, the removal tool should be applied to the ring fitted with a tight fit. In non-separable bearings, the ring with a sliding fit is dismantled first and the ring with a tight fit is then removed.

### Removal of small bearings

For the extraction of small bearings, mechanical extraction devices, *Figure 19*, or hydraulic presses are suitable. Dismounting is made easier if there are withdrawal slots on the shaft or housing so that the withdrawal tool can be applied directly to the bearing ring with a tight fit.

Special devices are available for cases where withdrawal slots are not present.

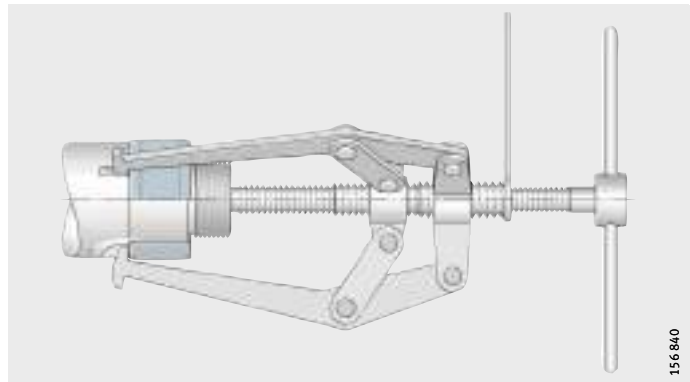

*Figure 19*  
Removal device  
with three adjustable arms







## Radial insert ball bearings

- Spherical outer ring
- Cylindrical outer ring
- Rubber interliner or steel aligning ring

## Radial insert ball bearings

<b>With eccentric locking collar</b> Spherical or cylindrical outer ring	..... 152
Radial insert ball bearings with spherical outer ring, for compensation of misalignments. Location on the shaft by means of a locking collar, which is preferably tightened in the direction of rotation and then secured.	
	..... 194
Radial insert ball bearings with cylindrical outer ring, eccentric locking collar and two slots in the outer ring. Axial location in cylindrical bores by means of snap rings.	
<b>With grub screws in inner ring</b>	..... 152
Radial insert ball bearings with spherical outer ring, for compensation of misalignments. Inner ring located on the shaft by means of grub screws. For bearing arrangements with a constant direction of rotation.	
<b>With adapter sleeve</b>	..... 152
Radial insert ball bearings with spherical outer ring, for compensation of misalignments. The inner ring is located on the shaft by means of an adapter sleeve with a locknut and a tab washer.	
<b>With drive slot</b>	..... 152
Radial insert ball bearings with spherical outer ring and drive slot in the inner ring. For compensation of misalignments. The slot prevents rotation.	
<b>Self-aligning deep groove ball bearings</b>	..... 152
Radial insert ball bearings with spherical outer ring, for compensation of misalignments. With cylindrical bore for a fit seat or with profiled bore for square or hexagonal shafts.	
<b>Deep groove ball bearings with extended inner ring</b>	..... 194
Radial insert ball bearings with cylindrical outer ring. Inner ring extended on both sides, which is located by means of a fit or hexagonal bore. Constant or alternating load.	
<b>With rubber interliner</b>	..... 212
Radial insert ball bearings with rubber interliner. Location on the shaft by means of eccentric locking collar. The NBR interliner absorbs vibrations and shocks.	
<b>With steel aligning ring</b>	..... 212
Radial insert ball bearings for mounting in cylindrical bores. Bearing with eccentric locking collar and additionally with an axially split outer ring as an aligning ring.	



(G)RAE...XL-NPP-B  
RALE...XL-NPP-B



G(N)E...XL-KRR-B  
(N)E...XL-KRR-B



GE...XL-KTT-B



GE...XL-KLL-B



GE...XL-KRR-B-2C

0008B325



RAE...XL-NPP  
RALE...XL-NPP



E...XL-KLL



E...XL-KRR



RAE...XL-NPP-NR

0008B32E



GAY...XL-NPP-B  
AY...XL-NPP-B



GYE...XL-KRR-B

0008B337



GSH...XL-2RSR-B

0008B341



GLE...XL-KRR-B

0008B34A



2...XL-NPP-B



GVK...KTT-B-AS2/V  
VK...KTT-B



SK...KRR-B  
SK...KTT-B

0008B353



2...XL-KRR  
2...XL-KRR-AH



SK...KRR



SK...KTT

0008B35C



RABRA-XL  
RABRB-XL



RCRA-XL  
RCRB-XL



CRB-XL

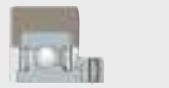

RCSMA-XL  
RCSMB-XL

0008B365



PE-XL



BE-XL

0008B36E



Features  
of radial insert ball bearings,  
comparison of series

Series	Shaft diameter				Location
	mm		inch		
	from	to	from	to	
<b>GE...XL-KLL-B</b>	20	50	–	–	Eccentric locking collar
<b>E...XL-KLL</b>	20	50	–	–	Eccentric locking collar
<b>GRAE...XL-NPP-B</b>	12	60	–	–	Eccentric locking collar
<b>GRA...NPP-B-AS2/V</b>	–	–	5/8	1 <sup>15</sup> /16	
<b>RABRB...XL-FA106</b>	12	50	–	–	Eccentric locking collar
<b>RABRA...XL-FA106</b>	30	–	–	–	
<b>RAE...XL-NPP-B</b>	12	50	–	–	Eccentric locking collar
<b>RA...NPP-B</b>	–	–	3/4	1 <sup>1</sup> /2	
<b>RALE...XL-NPP-B</b>	20	30	–	–	
<b>PE...XL</b>	20	40	–	–	
<b>RCSMB...XL-FA106</b>	15	25	–	–	Eccentric locking collar
<b>RCSMA...XL-FA106</b>	30	–	–	–	
<b>RCRA...XL-FA106</b>	20	–	–	–	
<b>RCRB...XL-FA106</b>	20	–	–	–	
<b>CRB...XL</b>	20	35	–	–	
<b>RAE...XL-NPP</b>	12	60	–	–	Eccentric locking collar
<b>RALE...XL-NPP</b>	20	30	–	–	
<b>RAE...XL-NPP-NR</b>	20	40	–	–	
<b>RA...NPP</b>	–	–	5/8	1 <sup>1</sup> /2	
<b>RAL...NPP</b>	–	–	3/4	–	
<b>GE...XL-KRR-B</b>	17	120	–	–	Eccentric locking collar
<b>G...KRR-B-AS2/V</b>	–	–	15/16	2 <sup>15</sup> /16	Eccentric locking collar
<b>GE...XL-KRR-B-2C</b>	25	40	–	–	
<b>GNE...XL-KRR-B</b>	30	100	–	–	Eccentric locking collar
<b>E...XL-KRR-B</b>	25	40	–	–	
<b>NE...XL-KRR-B</b>	50	–	–	–	
<b>GE...XL-KRR-B-FA101</b>	20	75	–	–	Eccentric locking collar
<b>GE...XL-KRR-B-FA164</b>	20	90	–	–	
<b>E...XL-KRR</b>	20	70	–	–	Eccentric locking collar
<b>GE...XL-KTT-B</b>	20	80	–	–	Eccentric locking collar
<b>GAY...XL-NPP-B</b>	12	60	–	–	Grub screws
<b>GAY...NPP-B-AS2/V</b>	–	–	5/8	1 <sup>7</sup> /16	
<b>GYE...XL-KRR-B</b>	12	90	–	–	
<b>GY...KRR-B-AS2/V</b>	–	–	1/2	2 <sup>15</sup> /16	
<b>AY...XL-NPP-B</b>	12	30	–	–	Grub screws
<b>GAY...XL-NPP-B-FA164</b>	12	15	–	–	Grub screws
<b>GLE...XL-KRR-B</b>	20	70	–	–	Drive slot
<b>BE...XL</b>	20	40	–	–	Fit
<b>2...XL-NPP-B</b>	12	50	–	–	Fit
<b>2...XL-KRR(-AH)</b>	13	60	–	–	
<b>SK(E)...KRR-B</b>	16,1	38,1	–	–	Hexagonal bore
<b>SK...KRR</b>	–	–	7/8	1 <sup>1</sup> /4	
<b>SK...KTT-B</b>	–	–	7/8	1 <sup>1</sup> /4	Hexagonal bore
<b>SK...KTT</b>	–	–	1 <sup>1</sup> /4	1 <sup>3</sup> /4	
<b>GSH...XL-2RSR-B</b>	20	50	–	–	Adapter sleeve
<b>GVK(E)...KRR-B-AS2/V</b>	16,3	–	–	–	Square bore
<b>VK(E)...KTT-B</b>	25,4	38	1	–	
<b>GVK(E)...KTT-B(-AS2/V)</b>	25,4	39,7	1	1 <sup>9</sup> /16	

1) Further guidelines must be observed, see page 62.

2) Recommended operating temperature.

If temperatures exceed +100 °C, relubrication must be carried out regularly.

3) Temporary temperature peaks are possible up to +120 °C.

Accessories	Sealing	Compensation of misalignment	Internal clearance Group	Cage	Grease <sup>1)</sup>		Relubrication facility	Temperature <sup>2)</sup> °C		Comments	Dimension table Page
								from	to		
–	L	yes	5	Steel	L069		yes	–40	+180	–	166
–	L	no	3	PA66	GA13		no	–20	+100 <sup>3)</sup>	–	202
–	P	yes	3	PA66	GA13		yes	–20	+100 <sup>3)</sup>	–	166 188
Rubber interliner	P	yes	3	PA66	GA13		no	–20	+85	–	218
										Light series	218
–	P	yes	3	PA66	GA13		no	–20	+100 <sup>3)</sup>	–	166
										–	188
										Light series	166
Aligning ring										Annular slots in aligning ring	220
Rubber interliner	P	no	3	PA66	GA13		no	–20	+85	–	218
										Light series	218
										Light series, mounting chamfer	218
										Mounting chamfer	218
										Abutment shoulder	218
–	P	no	3	PA66	GA13		no	–20	+100 <sup>3)</sup>	–	202
										–	202
										Two slots, one snap ring	202
										–	210
										–	210
–	R	yes	3	PA66	GA13		yes	–20	+100 <sup>3)</sup>	–	166
–	R	yes	3	PA66	GA13		yes	–20	+100 <sup>3)</sup>	–	188
										Flinger shields	166
										Heavy series	168
–	R	yes	3	PA66	GA13		no	–20	+100 <sup>3)</sup>	–	166
										Heavy series	170
–	R	yes	5	Steel	L069		yes	–40	+180	PTFE seal lip	166
					GA11			+150	+250		166
–	R	no	3	PA66	GA13		no	–20	+100 <sup>3)</sup>	–	202
–	T	yes	3	PA66	GA13		yes	–20	+100 <sup>3)</sup>	–	166
–	P	yes	3	PA66	GA13		yes	–20	+100 <sup>3)</sup>	–	174 188 174 188
–	P	yes	3	PA66	GA13		no	–20	+100 <sup>3)</sup>	–	174
–	P	yes	5	Steel	GA11		yes	+150	+250	PTFE seal lip	174
–	R	yes	5	Steel	L069		yes	–40	+180	PTFE seal lip	180
Aligning ring	P	yes	N	PA66	GA13		no	–20	+100 <sup>3)</sup>	Annular slots in aligning ring	220
–	R	yes	N	PA66	GA13		no	–20	+100 <sup>3)</sup>	–	182
		no									206
–	R	yes	3	PA66	GA13		no	–20	+100 <sup>3)</sup>	Corrosion-resistant, maximum greasing	186
		no									208
–	T	yes	3	PA66	L402		no	–20	+100 <sup>3)</sup>	Corrosion-resistant, maximum greasing	186
		no			GA13						208
–	RSR	yes	4	PA66	GA13		yes	–20	+100 <sup>3)</sup>	–	178
–	R	yes	3	PA66	GA13		yes	–20	+100 <sup>3)</sup>	Corrosion-resistant, maximum greasing	184
	T						no				184
	T						yes				184



# Design and safety guidelines

The chapter Technical principles brings together the essential guidelines on the design of bearing arrangements, lubrication, mounting and dismounting and the operation of bearings, see page 32.

## Compensation of static misalignments

Bearings with a spherical outer ring, fitted in housings with a concave bore, can compensate for static misalignment of the shaft, *Figure 1*.

For units with a lubrication groove in the housing and lubrication hole in the radial insert ball bearing, the following applies:

- Up to  $\pm 2,5^\circ$ , the units can be relubricated.
- Between  $\pm 2,5^\circ$  and  $\pm 5^\circ$ , the possibility of relubrication is dependent on the specific unit. Please contact us in this case.
- Over  $\pm 5^\circ$ , relubrication is no longer possible.



The units must not be used to support swivelling or tumbling motion.



*Figure 1*  
Compensation of static shaft misalignment

## Minimum radial load

In order to ensure slippage-free operation, the bearings must be subjected to a minimum radial load. This applies particularly in the case of high speeds and high accelerations. In continuous operation, a minimum radial load of the order of  $P \cong 0,01 \cdot C_r$  is necessary for ball bearings with cage.

## Speed limits for radial insert ball bearings

The speed limits are dependent on the load, the clearance between the bearing bore and shaft and the friction of the seals in the case of bearings with contact seals.

Guide values for the permissible speeds can be derived from the diagram, *Figure 2*, page 149.

In the case of load ratios  $C_r/P > 13$ , the speeds can be increased. For  $C_r/P < 5$ , location by means of a fit with a shaft roughness of  $R_a 0,3$  is recommended, see page 100. For both types of applications, please contact us. In order to ensure slippage-free operation, the minimum radial load must be observed.

Example of permissible speed calculation

Given:

- Shaft tolerance h6 Ⓣ
- Radial insert ball bearing GRAE30-XL-NPP-B
- Ball set 206
- Basic dynamic load rating  $C_r$  20 700 N
- Load P 1 300 N
- Sealing Seals P.

Required:

- Load ratio  $C_r/P = 20\,700\text{ N}/1\,300\text{ N}$   $C_r/P > 13$
- Permissible speed  $n \approx 4\,300\text{ min}^{-1}$ , Figure 2.



$n$  = permissible speed  
 $h5, h6, h9$  = shaft tolerance (this is subject to the envelope requirement Ⓣ)  
 $C_r/P$  = load ratio

- ① Ball set
- ② For  $d = 12\text{ mm}, 15\text{ mm}$  and  $17\text{ mm}$ , identical ball set 203
- ③ For radial insert ball bearings with seals L, P or R
- ④ For radial insert ball bearings with seals T

Figure 2 Permissible speeds for radial insert ball bearings

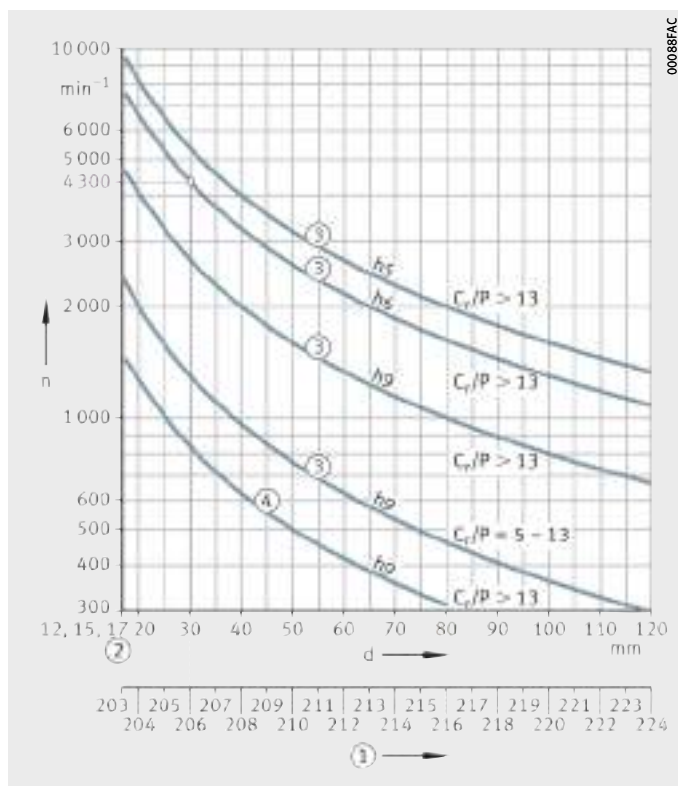

### Shaft tolerances for radial insert ball bearings

The permissible shaft tolerance is dependent on the speed and load. Shafts up to tolerance class h9 Ⓣ can be used. Conventional drawn shafts will suffice for most applications.

# Accuracy

## Standard tolerances of radial insert ball bearings

The outside diameter of the bearings corresponds to tolerance class Normal in accordance with ISO 492, see table. The inner ring bore has a plus tolerance to facilitate mounting of the bearing.

### Tolerances of radial insert ball bearings

Inner ring				Outer ring			
Nominal dimension Bore d mm		Deviation $t_{\Delta dmp}$ $\mu m$		Nominal dimension Outside diameter D mm		Deviation <sup>1)2)</sup> $t_{\Delta Dmp}$ $\mu m$	
over	incl.	U	L	over	incl.	U	L
12	18	+18	0	30	50	0	-11
18	24	+18	0	50	80	0	-13
24	30	+18	0	80	120	0	-15
30	40	+18	0	120	150	0	-18
40	50	+18	0	150	180	0	-25
50	60	+18	0	180	250	0	-30
60	90	+25	0	-	-	-	-
90	120	+30	0	-	-	-	-

U = upper limit deviation

L = lower limit deviation

Tolerance symbols, see tables, page 90.

1) In the case of sealed bearings, the largest and smallest values of the outside diameter can deviate from the mean value by approximately 0,03 mm.

2) Outside diameter tolerances also valid for 2...-KRR and 2...-NPP-B.

## Radial internal clearance of radial insert ball bearings

The radial internal clearance of most series is Group 3 to ISO 5753-1 and is thus larger than for normal deep groove ball bearings, see table and page 146.

The larger internal clearance allows better support of angular misalignment and shaft deflection.

### Radial internal clearance

Bore d mm		Radial internal clearance							
		Group N $\mu m$		Group 3 $\mu m$		Group 4 $\mu m$		Group 5 $\mu m$	
over	incl.	min.	max.	min.	max.	min.	max.	min.	max.
2,5	6	2	13	8	23	-	-	-	-
6	10	2	13	8	23	14	29	20	37
10	18	3	18	11	25	18	33	25	45
18	24	5	20	13	28	20	36	28	48
24	30	5	20	13	28	23	41	30	53
30	40	6	20	15	33	28	46	40	64
40	50	6	23	18	36	30	51	45	73
50	65	8	28	23	43	38	61	55	90
65	80	10	30	25	51	46	71	65	105
80	100	12	36	30	58	53	84	75	120
100	120	15	41	36	66	61	97	90	140
120	140	18	48	41	81	71	114	105	160
140	160	18	53	46	91	81	130	120	180







## Radial insert ball bearings with spherical outer ring

# Radial insert ball bearings with spherical outer ring

	Page
<b>Product overview</b>	Radial insert ball bearings with spherical outer ring..... 154
<b>Features</b>	X-life ..... 157
	Inch size designs..... 158
	Corrosion-resistant radial insert ball bearings ..... 158
	Radial insert ball bearings for high and low temperatures..... 158
	Radial insert ball bearings with eccentric locking collar ..... 159
	Radial insert ball bearings with grub screws in inner ring..... 160
	Radial insert ball bearings with adapter sleeve..... 161
	Radial insert ball bearings with drive slot ..... 162
	Self-aligning deep groove ball bearings with bore for fit..... 163
	Self-aligning deep groove ball bearings with profiled bore..... 164
	Suffixes..... 165
<b>Dimension tables</b>	Radial insert ball bearings with eccentric locking collar ..... 166
	Radial insert ball bearings with grub screws in inner ring..... 174
	Radial insert ball bearings with adapter sleeve..... 178
	Radial insert ball bearings with drive slot, non-locating bearings..... 180
	Self-aligning deep groove ball bearings, bore for fit..... 182
	Self-aligning deep groove ball bearings, square bore ..... 184
	Self-aligning deep groove ball bearings, hexagonal bore ..... 186
	Inch size radial insert ball bearings..... 188



# Product overview Radial insert ball bearings with spherical outer ring

## With eccentric locking collar

(G)RAE...-XL-NPP-B,  
RALE...-XL-NPP-B



GE...-XL-KTT-B

G(N)E...-XL-KRR-B,  
(N)E...-KRR-B



GE...-XL-KLL-B



GE...-XL-KRR-B-2C



## With grub screws in inner ring

GAY...-XL-NPP-B, AY...-XL-NPP-B



GYE...-XL-KRR-B



**With adapter sleeve**

GSH..-XL-2RSR-B



**With drive slot**

GLE..-XL-KRR-B



**Self-aligning  
deep groove ball bearings**

With bore for fit

2..-XL-NPP-B



## Product overview

## Radial insert ball bearings with spherical outer ring

**Self-aligning deep groove ball bearings with profiled bore**  
With square bore

GVK(E),  
VK..-KTT-B



With hexagonal bore

SK..-KRR-B



SK..-KTT-B



**Inch size radial insert ball bearings**  
With eccentric locking collar

GRA..-NPP-B-AS2/V,  
RA..-NPP-B



G..-KRR-B-AS2/V



With grub screws in inner ring

GY..-KRR-B-AS2/V



GAY..-NPP-B(-AS2/V)



# Radial insert ball bearings with spherical outer ring



**Features** Radial insert ball bearings with spherical outer ring are single row, ready-to-fit units comprising a solid outer ring, cages made from plastic or sheet steel and seals P, R, L or T. Bearings with an inner ring extended on both sides undergo less tilting of the inner ring and therefore run more smoothly.

The outer ring has a spherical outside surface. In combination with a housing matched to the design, bearings with a spherical outer ring can compensate for misalignment of the shaft, see section Compensation of static misalignments, page 148.

With only a few exceptions, radial insert ball bearings can be relubricated. For this purpose, they have two lubrication holes in one plane of the outer ring offset by 180°.

Radial insert ball bearings are particularly easy to fit and are preferentially suitable for drawn shafts of tolerance classes h6  $\oplus$  to h9  $\oplus$ . For non-locating bearings, shafts of tolerance class h5  $\oplus$  to h7  $\oplus$  are recommended. They are located on the shaft by means of an eccentric locking collar, grub screws in the inner ring, an adapter sleeve, a drive slot, fit or profiled bore.



The series comparison matrix presents the features of the series in detail, see table, page 146.

## X-life

Numerous sizes are supplied in the X-life design. These products are indicated in the dimension tables.

Radial insert ball bearings of X-life quality have, for example, lower roughness Ra and higher geometrical accuracy of the raceways than comparable designs that are not X-life. As a result, these bearings have higher load carrying capacity and longer rating life although their dimensions are identical. In certain applications, this means that a smaller bearing arrangement can be designed.

Radial insert ball bearings of X-life quality have an eccentric locking collar of an improved design and the quantity and distribution of the lubricant has been optimised. Housings ASE have additional crosspieces on the underside. For extreme requirements, the cage and seal material in the high and low temperature designs (suffix FA101) has been significantly improved in comparison with earlier versions.

## Radial insert ball bearings with spherical outer ring

### Inch size designs

Some series with an eccentric locking collar or grub screws in the inner ring are also available with inch size bore dimensions, see page 188.

### Corrosion-resistant radial insert ball bearings

For corrosion-resistant bearing arrangements and for applications in the food and drinks industry, bearings with a Corrotect coating under the suffix FA125 and bearings of a corrosion-resistant design are available. Corrosion-resistant radial insert ball bearings are suitable where moisture, contaminated water, salt spray mist or weakly alkaline and weakly acidic cleaning agents are present, see section Radial insert ball bearings and housing units, corrosion-resistant, page 349.

### Radial insert ball bearings for high and low temperatures

At high temperatures, rolling bearings expand in volume due to a change in the material microstructure. Depending on the location of the heat source, there may also be a significant temperature differential between the inner and outer ring.

The radial insert ball bearings are not dimensionally stabilised but have an increased internal clearance Group 5. They have cages made from metal or a high temperature plastic, lubricants with improved thermal resistance and special seals.

These bearings have the suffix FA164 or FA101, see table, page 165. An extended temperature range can also be covered by using the series GLE...XL-KRR-B and GE...XL-KLL-B, see table, page 146.



**Radial insert ball bearings with eccentric locking collar**

These “classic” INA radial insert ball bearings are located on the shaft by means of a locking collar, *Figure 1*. They are particularly suitable for bearing arrangements with a constant direction of rotation or, under low speed and load, for an alternating direction of rotation.

The locking collar is preferably tightened in the direction of rotation and secured by means of a grub screw. This location method prevents damage to the shaft and can be easily loosened again.



**GE..-XL-KRR-B**

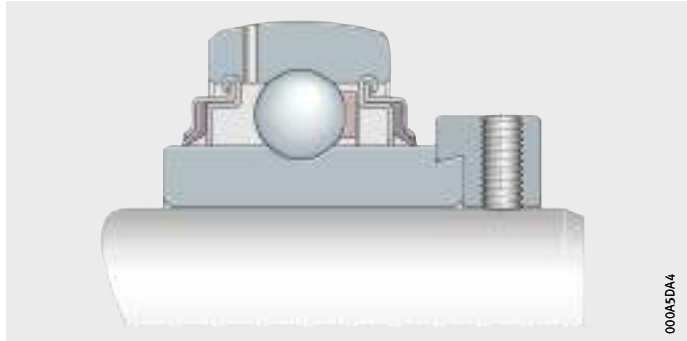

*Figure 1*  
Location  
by means of eccentric locking collar

**Sealing**

The radial insert ball bearings are sealed by means of seals P, R, L or T, see page 119. In the case of series GE..-XL-KRR-B-2C, the seals R have outer flinger shields with Corroprotect coating for protection against mechanical damage.

**Lubrication**

With the exception of a few series, sealed bearings can be relubricated.

**Anti-corrosion protection**

Several series are also available in a corrosion-resistant design. These bearings have the suffix FA125.

The inner rings up to  $d = 60$  mm and the locking collars in general have a Corroprotect coating and are thus protected against fretting corrosion. This is not valid for the series RALE..-XL-NPP(-B).

**Radial insert ball bearings for high and low temperatures**

The series for high or expanded temperature ranges have the suffixes FA164 or FA101, see table, page 146.

**Cylindrical outer ring**

In addition to the bearings with a spherical outer ring, there are also the following series with a cylindrical outer ring: RAE..-XL-NPP, RALE..-XL-NPP, E..-XL-KRR and E..-XL-KLL, see section Radial insert ball bearings with cylindrical outer ring, page 194.

**Inch size designs**

The series GRA..-NPP-B-AS2/V, RA..-NPP-B, G..-KRR-B-AS2/V have an inch size bore diameter, see page 188.

**Tightening torques**

The tightening torques for metric and inch size grub screws must be observed, see table, page 130.

## Radial insert ball bearings with spherical outer ring

### Radial insert ball bearings with grub screws in inner ring

In the case of these radial insert ball bearings, the inner ring is located on the shaft by means of two grub screws offset by 120°, *Figure 2*. This location method is suitable for bearing arrangements with a constant direction of rotation or, under low speed and load, for an alternating direction of rotation.

The grub screws are self-retaining and have a fine pitch thread with cup point for secure location of the bearings.

GYE..-XL-KRR-B

*Figure 2*  
Location  
by means of grub screws  
in the inner ring

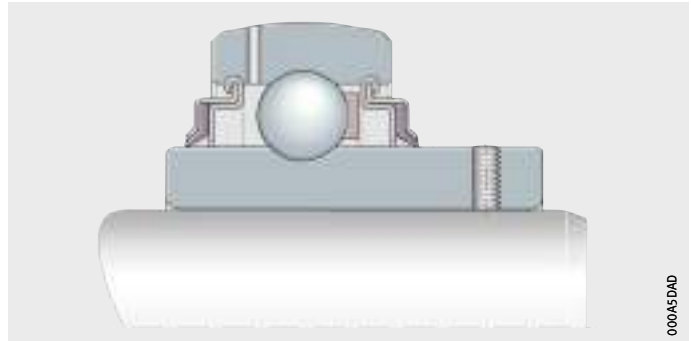

#### Sealing

The radial insert ball bearings are sealed on both sides by means of seals P or R, see page 119.

#### Lubrication

With the exception of series AY..-XL-NPP-B, the bearings can be relubricated.

#### Anti-corrosion protection

The radial insert ball bearings are also available in a corrosion-resistant design with bearing rings and rolling elements made from high alloy, corrosion-resistant rolling bearing steel with an increased chromium and molybdenum content. The steel cages are made from corrosion-resistant steel.

The bearings are sealed on both sides by means of seals RSR and have additional outer flinger shields made from corrosion-resistant steel, see section Radial insert ball bearings and housing units, corrosion-resistant, page 349.

#### Radial insert ball bearings for high temperatures

The radial insert ball bearings for high temperatures have the suffix FA164, see table, page 146.

#### Inch size designs

In the case of series GY..-KRR-B-AS2/V, the bore is of inch dimensions, see page 188.

#### Tightening torques

The tightening torques for metric and inch size grub screws must be observed, see table, page 130.

## Radial insert ball bearings with adapter sleeve

In the case of this series, the inner ring is located on the shaft by means of an adapter sleeve with a locknut and a tab washer, *Figure 3*. These radial insert ball bearings are suitable for shafts up to tolerance class h11 .

This location method is suitable for bearing arrangements with a constant or alternating direction of rotation and for high speeds.

The adapter sleeve and locknut give concentric, force locking location of the bearing inner ring on the shaft. As a result, the speeds that can be achieved are approximately the same as with deep groove ball bearings. These bearings also give quieter running than normal radial insert ball bearings. The adapter sleeve, locknut and tab washer are all zinc plated.

The bearings are highly suitable for reversing operation. As a result of the force locking connection, there is no occurrence of fretting corrosion between the shaft and the bore of the adapter sleeve.

Due to the integral adapter sleeve, the bearings have the same radial dimensions as and slightly lower basic load ratings than radial insert ball bearings with an eccentric locking collar or with grub screws in the inner ring and are interchangeable with these bearings.



GSH..-XL-2RSR-B

*Figure 3*  
Location  
using adapter sleeve and locknut

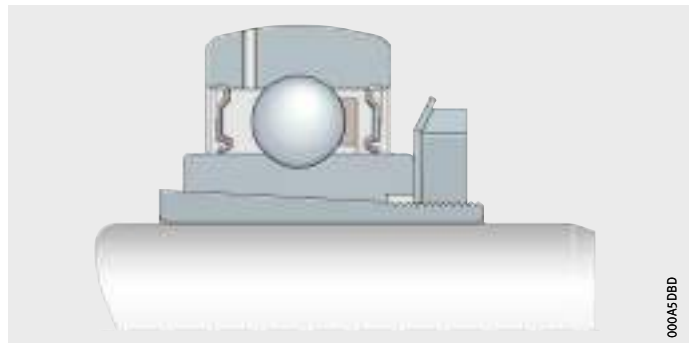

**Sealing** Radial insert ball bearings with an integral adapter sleeve are sealed by means of seals RSR, see page 119.



**Lubrication** The bearings can be relubricated.

**Hook wrenches and tightening torques** The permissible tightening torques for the locknut must be observed, see table, page 132. Hook wrenches in accordance with DIN 1810 are available from the Industrial Service function of Schaeffler, see page 592.

## Radial insert ball bearings with spherical outer ring

### Radial insert ball bearings with drive slot

Radial insert ball bearings with a drive slot in the inner ring are non-locating bearings with good high temperature characteristics, *Figure 4*. Non-locating bearings are used at low speeds and loads to compensate for thermal elongation of the shaft.

Due to the slot, they are easy to locate in a radial direction. Rotation is prevented by means of a drive pin on the shaft or a set collar with a pin. The non-locating bearings are suitable for drawn shafts of tolerance classes h5  to h7 .

GLE..-XL-KRR-B

*Figure 4*

Location by means of drive slot

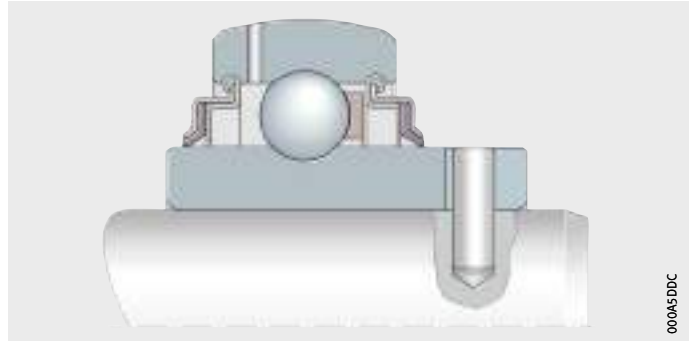

#### Anti-corrosion protection

The inner rings up to a bore diameter  $d = 60$  mm have a Corrotect coating and are thus protected against fretting corrosion.

#### Sealing

Radial insert ball bearings with a drive slot have seals R with lip seals made from PTFE, see page 119.

#### Lubrication

The bearings can be relubricated.

## Self-aligning deep groove ball bearings with bore for fit

Self-aligning deep groove ball bearings are available with a cylindrical bore for a fit seat, *Figure 5*, or with a reamed square or hexagonal bore, *Figure 6*.

Bearings with a fit seat on the shaft can achieve the same speeds as standard ball bearings. These are suitable for bearings with an alternating direction of rotation and offer smooth running.



2..-XL-NPP-B

*Figure 5*  
Self-aligning deep groove ball bearings with fit seat

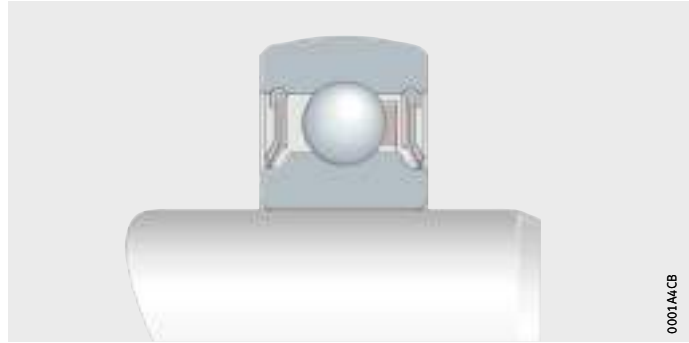

### Sealing

The bearings are sealed on both sides using P seals with a vulcanised seal lip or three-piece designs, see page 119.



For self-aligning deep groove ball bearings with a fit seat, the fit data for ball bearings apply.

## Radial insert ball bearings with spherical outer ring

### Self-aligning deep groove ball bearings with profiled bore

Bearings with a profiled bore are used where shafts must transmit very high torques and this is only possible using square or hexagonal shafts, *Figure 6*. Rotation is prevented by form fit. Shafts of tolerance class h11  $\oplus$  are recommended.

VK..-KTT-B  
SK..-KRR-B

- ① Square bore
- ② Hexagonal bore

*Figure 6*  
Self-aligning deep groove ball bearings with profiled bore

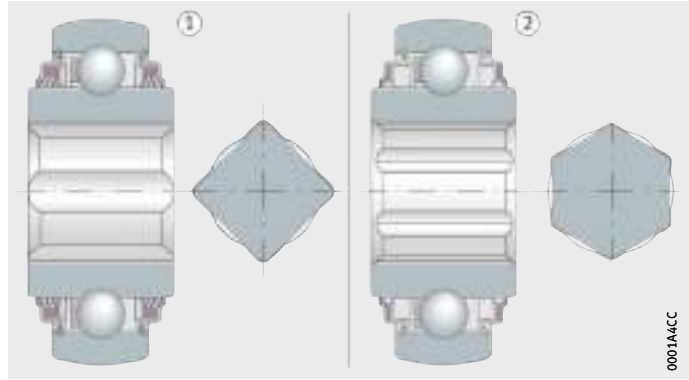

#### Anti-corrosion protection

The bearings have a Corrotect coating.

#### Sealing

The self-aligning deep groove ball bearings are sealed using seals R or T, see page 119.

#### Lubrication

The bearings are greased to their maximum, some designs can also be relubricated.



**Suffixes** Suffixes for available designs, see table.

**Available designs**

Suffix	Description	Design
AS2/V	Bearing outer ring with two lubrication holes in offset planes	Standard
B	Bearing with spherical outer ring	
2C	Flinger shields on both sides	
FA101	High and low temperature design -40 °C to +180 °C	
FA106	Bearing subjected to special noise testing	
FA107	Bearing with lubrication holes on the locating side	
FA125	With Corrotect coating, corrosion-resistant	
FA164	High temperature design up to +250 °C	
KRR	Lip seals on both sides (seal R)	
KLL	Labyrinth seals on both sides (seal L)	
KTT	Triple lip seals on both sides (seal T)	
NR	Slot and snap ring for radial insert ball bearing with cylindrical outer ring	
NPP	Lip seals on both sides (seal P)	
OSE	Bearing without locking element (eccentric locking collar)	
2RSR	Lip seals on both sides (vulcanised)	

# Radial insert ball bearings with eccentric locking collar

Spherical outer ring

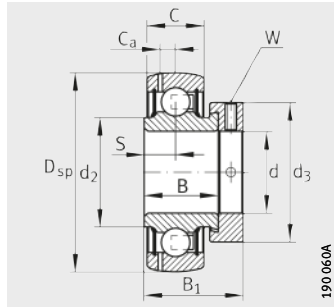

GRAE..-XL-NPP-B

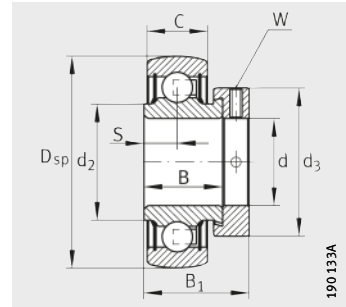

RAE..-XL-NPP-B, RALE..-XL-NPP-B

**Dimension table** - Dimensions in mm

Designation <sup>1)</sup>	Mass m ≈ kg	Dimensions							
		d	D <sub>sp</sub>	C	C <sub>2</sub>	B	S	d <sub>1</sub>	d <sub>2</sub>
GRAE12-XL-NPP-B	0,13	12	40	12	–	19	6,5	–	23
RAE12-XL-NPP-B	0,13	12	40	12	–	19	6,5	–	23
GRAE15-XL-NPP-B	0,11	15	40	12	–	19	6,5	–	23
RAE15-XL-NPP-B	0,12	15	40	12	–	19	6,5	–	23
GE17-XL-KRR-B	0,12	17	40	12	16,6	27,8	13,9	23,9	–
GRAE17-XL-NPP-B	0,12	17	40	12	–	19	6,5	–	23
RAE17-XL-NPP-B	0,1	17	40	12	–	19	6,5	–	23
GE20-XL-KLL-B	0,2	20	47	14	16,6	34,1	17,1	27,6	–
GE20-XL-KRR-B	0,19	20	47	14	16,6	34,1	17,1	27,6	–
GE20-XL-KRR-B-FA164	0,2	20	47	14	16,6	34,1	17,1	27,6	–
GE20-XL-KTT-B	0,19	20	47	14	16,6	34,1	17,1	27,6	–
GRAE20-XL-NPP-B	0,16	20	47	14	–	21,4	7,5	–	26,9
RAE20-XL-NPP-B	0,16	20	47	14	–	21,4	7,5	–	26,9
RALE20-XL-NPP-B	0,1	20	42	12	–	16,7	6	–	25,4
E25-XL-KRR-B	0,24	25	52	15	16,7	34,9	17,5	33,8	–
GE25-XL-KRR-B	0,25	25	52	15	16,7	34,9	17,5	33,8	–
GE25-XL-KRR-B-FA101	0,24	25	52	15	16,7	34,9	17,5	33,8	–
GE25-XL-KRR-B-FA164	0,25	25	52	15	16,7	34,9	17,5	33,8	–
GE25-XL-KLL-B	0,25	25	52	15	20,2	34,9	17,5	33,8	–
GE25-XL-KTT-B	0,24	25	52	15	20,2	34,9	17,5	33,8	–
GE25-XL-KRR-B-2C	0,26	25	52	15	24,6	34,9	17,5	33,8	–
GRAE25-XL-NPP-B	0,19	25	52	15	–	21,4	7,5	–	30,5
RAE25-XL-NPP-B	0,19	25	52	15	–	21,4	7,5	–	30,5
RALE25-XL-NPP-B	0,12	25	47	12	–	17,5	6	–	30

<sup>1)</sup> Permissible speeds of radial insert ball bearings: see page 148.

<sup>2)</sup> Factor  $f_0$  for determining equivalent bearing load, see table, page 40.



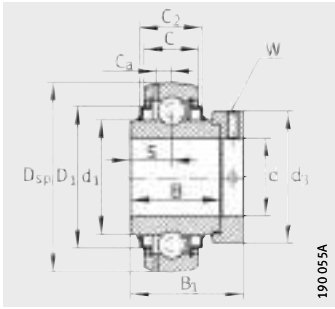

GE..-XL-KRR-B

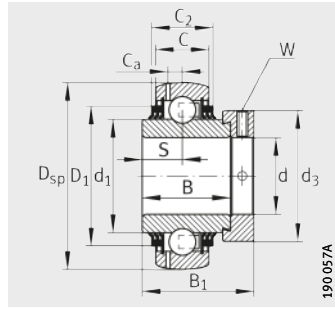

GE..-XL-KTT-B

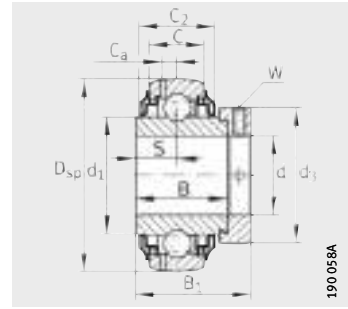

GE..-XL-KRR-B-2C



D <sub>1</sub>	C <sub>a</sub>	B <sub>1</sub>	d <sub>3</sub> max.	Width across flats W	Basic load ratings		Fatigue limit load C <sub>ur</sub> N	Factor <sup>2)</sup> f <sub>0</sub>
					dyn. C <sub>r</sub> N	stat. C <sub>0r</sub> N		
-	3,4	28,6	28,4	3	10 100	4 750	241	13,1
-	-	28,6	28,4	3	10 100	4 750	241	13,1
-	3,4	28,6	28,4	3	10 100	4 750	241	13,1
-	-	28,6	28,4	3	10 100	4 750	241	13,1
31,6	3,4	37,4	28,4	3	10 100	4 750	241	13,1
-	3,4	28,6	28,4	3	10 100	4 750	241	13,1
-	-	28,6	28,4	3	10 100	4 750	241	13,1
37,4	4	43,7	33	3	13 600	6 600	335	13,1
37,4	4	43,7	33	3	13 600	6 600	335	13,1
37,4	4	43,7	33	3	13 600	6 600	335	13,1
37,4	4	43,7	33	3	13 600	6 600	335	13,1
-	4	31	33	3	13 600	6 600	335	13,1
-	-	31	33	3	13 600	6 600	335	13,1
-	-	24,5	30	2,5	10 000	5 000	255	13,9
42,5	-	44,5	37,5	3	14 900	7 800	395	13,8
42,5	4,1	44,5	37,5	3	14 900	7 800	395	13,8
42,5	4,1	44,5	37,5	3	14 900	7 800	395	13,8
42,5	4,1	44,5	37,5	3	14 900	7 800	395	13,8
42,5	4,1	44,5	37,5	3	14 900	7 800	395	13,8
42,5	4,1	44,5	37,5	3	14 900	7 800	395	13,8
-	4,1	44,5	37,5	3	14 900	7 800	395	13,8
-	4,1	31	37,5	3	14 900	7 800	395	13,8
-	-	31	37,5	3	14 900	7 800	395	13,8
-	-	25,5	36	2,5	10 700	5 900	295	13,8

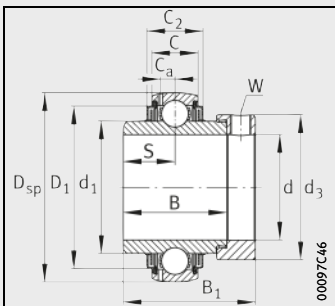

GE..-XL-KLL-B

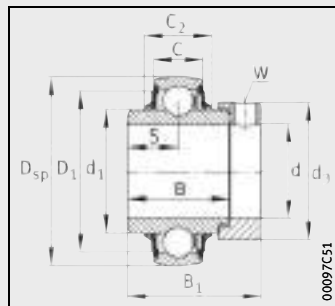

E..-XL-KRR-B

# Radial insert ball bearings with eccentric locking collar

Spherical outer ring

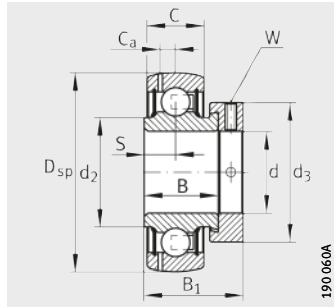

GRAE...XL-NPP-B

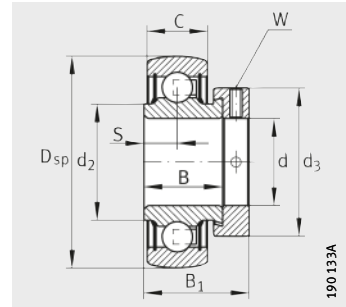

RAE...XL-NPP-B, RALE...XL-NPP-B

**Dimension table** (continued) · Dimensions in mm

Designation <sup>1)</sup>	Mass m ≈ kg	Dimensions							
		d	D <sub>sp</sub>	C	C <sub>2</sub>	B	S	d <sub>1</sub>	d <sub>2</sub>
<b>GE30-XL-KLL-B</b>	0,39	<b>30</b>	62	18	20,6	36,5	18,3	40,2	–
<b>E30-XL-KRR-B</b>	0,39	<b>30</b>	62	18	20,7	36,5	18,3	40,2	–
<b>GE30-XL-KRR-B</b>	0,39	<b>30</b>	62	18	20,7	36,5	18,3	40,2	–
<b>GE30-XL-KRR-B-FA101</b>	0,38	<b>30</b>	62	18	20,7	36,5	18,3	40,2	–
<b>GE30-XL-KRR-B-FA164</b>	0,39	<b>30</b>	62	18	20,7	36,5	18,3	40,2	–
<b>GE30-XL-KTT-B</b>	0,38	<b>30</b>	62	18	20,7	36,5	18,3	40,2	–
<b>GNE30-XL-KRR-B</b>	0,63	<b>30</b>	72	20	24	36,6	17,5	44	–
<b>GE30-XL-KRR-B-2C</b>	0,41	<b>30</b>	62	18	27,2	36,5	18,3	40,2	–
<b>GRAE30-XL-NPP-B</b>	0,32	<b>30</b>	62	18	–	23,8	9	–	37,4
<b>RAE30-XL-NPP-B</b>	0,32	<b>30</b>	62	18	–	23,8	9	–	37,4
<b>RALE30-XL-NPP-B</b>	0,18	<b>30</b>	55	13	–	18,5	6,5	–	35,7
<b>E35-XL-KRR-B</b>	0,59	<b>35</b>	72	19	22,5	37,7	18,8	46,8	–
<b>GE35-XL-KRR-B</b>	0,59	<b>35</b>	72	19	22,5	37,7	18,8	46,8	–
<b>GE35-XL-KRR-B-FA164</b>	0,61	<b>35</b>	72	19	22,5	37,7	18,8	46,8	–
<b>GE35-XL-KTT-B</b>	0,59	<b>35</b>	72	19	22,5	37,7	18,8	46,8	–
<b>GNE35-XL-KRR-B</b>	0,74	<b>35</b>	80	22	25	38,1	18,3	48	–
<b>GE35-XL-KLL-B</b>	0,6	<b>35</b>	72	19	25,4	37,7	18,8	46,8	–
<b>GE35-XL-KRR-B-2C</b>	0,63	<b>35</b>	72	19	29,2	37,7	18,8	46,8	–
<b>GRAE35-XL-NPP-B</b>	0,52	<b>35</b>	72	19	–	25,4	9,5	–	44,6
<b>RAE35-XL-NPP-B</b>	0,52	<b>35</b>	72	19	–	25,4	9,5	–	44,6

<sup>1)</sup> Permissible speeds of radial insert ball bearings: see page 148.

<sup>2)</sup> Factor  $f_0$  for determining equivalent bearing load, see table, page 40.

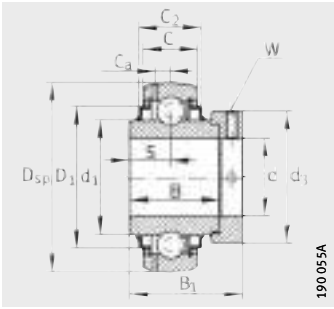

GE..-XL-KRR-B, GNE..-XL-KRR-B

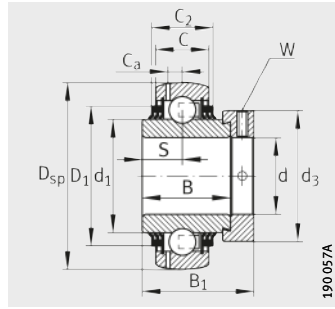

GE..-XL-KTT-B

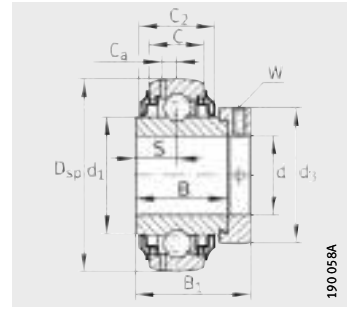

GE..-XL-KRR-B-2C



D <sub>1</sub>	C <sub>a</sub>	B <sub>1</sub>	d <sub>3</sub> max.	Width across flats W	Basic load ratings		Fatigue limit load C <sub>ur</sub> N	Factor <sup>2)</sup> f <sub>0</sub>
					dyn. C <sub>r</sub> N	stat. C <sub>0r</sub> N		
52	4,7	48,5	44	4	20 700	11 300	570	13,8
52	–	48,5	44	4	20 700	11 300	570	13,8
52	4,7	48,5	44	4	20 700	11 300	570	13,8
52	4,7	48,5	44	4	20 700	11 300	570	13,8
52	4,7	48,5	44	4	20 700	11 300	570	13,8
52	4,7	48,5	44	4	20 700	11 300	570	13,8
60,2	6,2	50,2	51	5	31 500	16 700	840	13
–	4,7	48,5	44	4	20 700	11 300	570	13,8
–	4,7	35,8	44	4	20 700	11 300	570	13,8
–	–	35,8	44	4	20 700	11 300	570	13,8
–	–	26,5	42,5	2,5	14 100	8 300	420	13,8
60,3	–	51,3	55	5	27 500	15 300	770	13,8
60,3	5,6	51,3	55	5	27 500	15 300	770	13,8
60,3	5,6	51,3	55	5	27 500	15 300	770	13,8
60,3	5,6	51,3	55	5	27 500	15 300	770	13,8
66,6	6,9	51,6	55	5	39 000	20 900	1 060	13,1
60,3	5,6	51,3	55	5	27 500	15 300	770	13,8
–	5,6	51,3	55	5	27 500	15 300	770	13,8
–	5,6	39	55	5	27 500	15 300	770	13,8
–	–	39	55	5	27 500	15 300	770	13,8

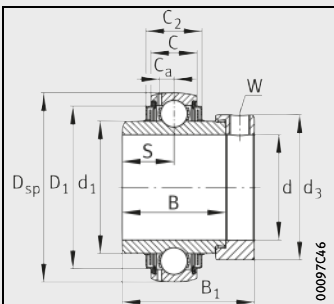

GE..-XL-KLL-B

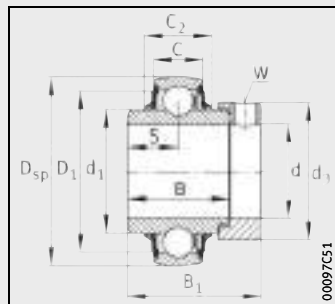

E..-XL-KRR-B

# Radial insert ball bearings with eccentric locking collar

Spherical outer ring

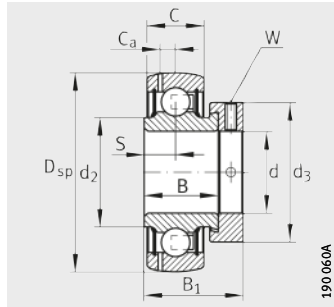

GRAE..-XL-NPP-B

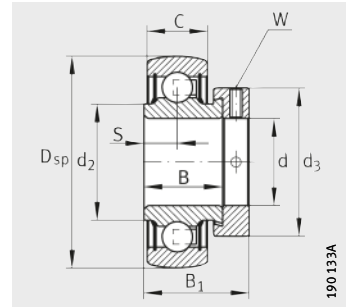

RAE..-XL-NPP-B

Dimension table (continued) · Dimensions in mm

Designation <sup>1)</sup>	Mass m ≈ kg	Dimensions							
		d	D <sub>sp</sub>	C	C <sub>2</sub>	B	S	d <sub>1</sub>	d <sub>2</sub>
<b>E40-XL-KRR-B</b>	0,73	<b>40</b>	80	21	23,5	42,9	21,4	52,3	–
<b>GE40-XL-KRR-B</b>	0,73	<b>40</b>	80	21	23,5	42,9	21,4	52,3	–
<b>GE40-XL-KRR-B-FA101</b>	0,74	<b>40</b>	80	21	23,5	42,9	21,4	52,3	–
<b>GE40-XL-KRR-B-FA164</b>	0,75	<b>40</b>	80	21	23,5	42,9	21,4	52,3	–
<b>GNE40-XL-KRR-B</b>	1,02	<b>40</b>	90	23	26	41	18	53,8	–
<b>GE40-XL-KLL-B</b>	0,75	<b>40</b>	80	21	28,1	42,9	21,4	52,3	–
<b>GE40-XL-KTT-B</b>	0,75	<b>40</b>	80	21	28,1	42,9	21,4	52,3	–
<b>GE40-XL-KRR-B-2C</b>	0,78	<b>40</b>	80	21	31,9	42,9	21,4	52,3	–
<b>GRAE40-XL-NPP-B</b>	0,62	<b>40</b>	80	21	–	30,2	11	–	49,4
<b>RAE40-XL-NPP-B</b>	0,63	<b>40</b>	80	21	–	30,2	11	–	49,4
<b>GE45-XL-KLL-B</b>	0,84	<b>45</b>	85	22	26,4	42,9	21,4	57,9	–
<b>GE45-XL-KRR-B</b>	0,83	<b>45</b>	85	22	26,4	42,9	21,4	57,9	–
<b>GE45-XL-KTT-B</b>	0,83	<b>45</b>	85	22	26,4	42,9	21,4	57,9	–
<b>GRAE45-XL-NPP-B</b>	0,7	<b>45</b>	85	22	–	30,2	11	–	54,3
<b>GE50-XL-KLL-B</b>	1	<b>50</b>	90	22	26,4	49,2	24,6	62,8	–
<b>GE50-XL-KRR-B</b>	0,99	<b>50</b>	90	22	26,4	49,2	24,6	62,8	–
<b>GE50-XL-KRR-B-FA101</b>	0,99	<b>50</b>	90	22	26,4	49,2	24,6	62,8	–
<b>GE50-XL-KRR-B-FA164</b>	0,99	<b>50</b>	90	22	26,4	49,2	24,6	62,8	–
<b>GE50-XL-KTT-B</b>	0,98	<b>50</b>	90	22	26,4	49,2	24,6	62,8	–
<b>GNE50-XL-KRR-B</b>	1,82	<b>50</b>	110	29	–	49,2	24,6	68,8	–
<b>GRAE50-XL-NPP-B</b>	0,77	<b>50</b>	90	22	–	30,2	11	–	59,4
<b>NE50-XL-KRR-B<sup>3)</sup></b>	1,82	<b>50</b>	110	29	–	49,2	24,6	68,8	–
<b>RAE50-XL-NPP-B</b>	0,77	<b>50</b>	90	22	–	30,2	11	–	59,4

<sup>1)</sup> Permissible speeds of radial insert ball bearings: see page 148.

<sup>2)</sup> Factor  $f_0$  for determining equivalent bearing load, see table, page 40.

<sup>3)</sup> No relubrication facility.

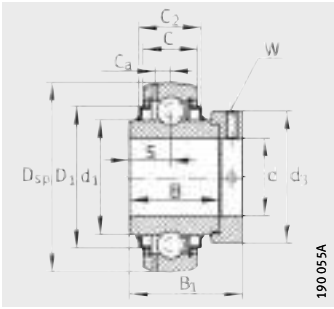

GE..-XL-KRR-B, GNE..-XL-KRR-B

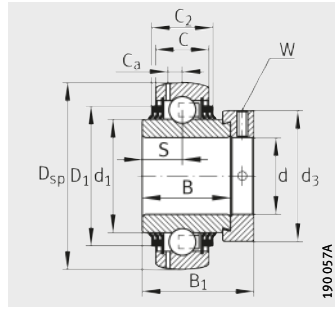

GE..-XL-KTT-B

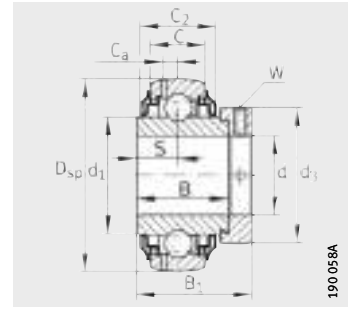

GE..-XL-KRR-B-2C



D <sub>1</sub>	C <sub>a</sub>	B <sub>1</sub>	d <sub>3</sub> max.	Width across flats W	Basic load ratings		Fatigue limit load C <sub>ur</sub> N	Factor <sup>2)</sup> f <sub>0</sub>
					dyn. C <sub>r</sub> N	stat. C <sub>0r</sub> N		
68,3	–	56,5	58	5	34 500	19 800	1 010	14
68,3	6,4	56,5	58	5	34 500	19 800	1 010	14
68,3	6,4	56,5	58	5	34 500	19 800	1 010	14
68,3	6,4	56,5	58	5	34 500	19 800	1 010	14
74,5	7,5	54,6	63	5	47 000	26 000	1 320	13
68,3	6,4	56,5	58	5	34 500	19 800	1 010	14
68,3	6,4	56,5	58	5	34 500	19 800	1 010	14
–	6,4	56,5	58	5	34 500	19 800	1 010	14
–	6,4	43,8	58	5	34 500	19 800	1 010	14
–	–	43,8	58	5	34 500	19 800	1 010	14
72,3	6,4	56,5	63	5	34 500	20 400	1 030	14,3
72,3	6,4	56,5	63	5	34 500	20 400	1 030	14,3
72,3	6,4	56,5	63	5	34 500	20 400	1 030	14,3
–	6,4	43,8	63	5	34 500	20 400	1 030	14,3
77,3	6,9	62,8	69	5	37 500	23 200	1 180	14,3
77,3	6,9	62,8	69	5	37 500	23 200	1 180	14,3
77,3	6,9	62,8	69	5	37 500	23 200	1 180	14,3
77,3	6,9	62,8	69	5	37 500	23 200	1 180	14,3
77,3	6,9	62,8	69	5	37 500	23 200	1 180	14,3
92,7	8,7	66,75	75,8	5	66 000	38 000	1 920	13
–	6,9	43,8	69	5	37 500	23 200	1 180	14,3
–	–	66,75	75,8	5	66 000	38 000	1 920	13
–	–	43,8	69	5	37 500	23 200	1 180	14,3

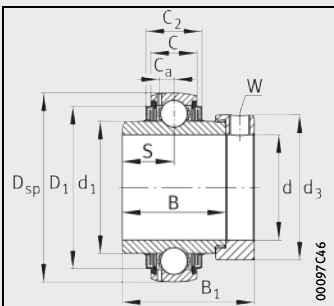

GE..-XL-KLL-B

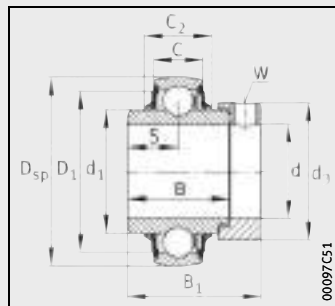

E..-XL-KRR-B, NE..-XL-KRR-B

# Radial insert ball bearings with eccentric locking collar

Spherical outer ring

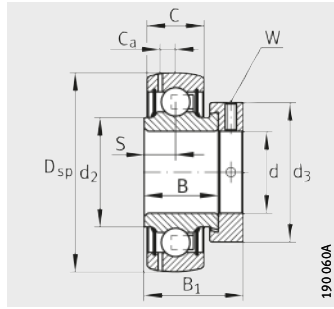

GRAE..XL-NPP-B

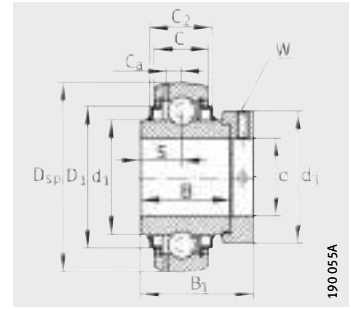

GE..XL-KRR-B, GNE..XL-KRR-B

Dimension table (continued) · Dimensions in mm

Designation <sup>1)</sup>	Mass m ≈ kg	Dimensions							
		d	D <sub>sp</sub>	C	C <sub>2</sub>	B	S	d <sub>1</sub>	d <sub>2</sub>
GE55-XL-KRR-B	1,37	55	100	25	29	55,5	27,8	69,8	–
GE55-XL-KTT-B	1,37	55	100	25	29	55,5	27,8	69,8	–
GRAE55-XL-NPP-B	1,06	55	100	25	–	32,5	12	–	66
GE60-XL-KRR-B	1,8	60	110	24	29	61,9	31	76,5	–
GE60-XL-KRR-B-FA101	1,8	60	110	24	29	61,9	31	76,5	–
GE60-XL-KRR-B-FA164	1,8	60	110	24	29	61,9	31	76,5	–
GE60-XL-KTT-B	1,8	60	110	24	29	61,9	31	76,5	–
GNE60-XL-KRR-B	2,97	60	130	33	37,2	52	23	79,4	–
GRAE60-XL-NPP-B	1,4	60	110	24	–	37,1	13,5	–	72
GE65-214-XL-KRR-B <sup>3)</sup>	2,71	65	125	28	32	48,5	21,5	85,2	–
GE65-214-XL-KRR-B-FA164 <sup>3)</sup>	2,71	65	125	28	32	48,5	21,5	85,2	–
GE65-214-XL-KTT-B <sup>3)</sup>	2,71	65	125	28	32	48,5	21,5	85,2	–
GE70-XL-KRR-B	2,15	70	125	28	32	48,5	21,5	85,2	–
GE70-XL-KRR-B-FA101	2,15	70	125	28	32	48,5	21,5	85,2	–
GE70-XL-KRR-B-FA164	2,15	70	125	28	32	48,5	21,5	85,2	–
GE70-XL-KTT-B	2,15	70	125	28	32	48,5	21,5	85,2	–
GNE70-XL-KRR-B	3,81	70	150	37	41	58	26	92,2	–
GE75-XL-KRR-B	2,14	75	130	28	30,5	49,5	21,5	90	–
GE75-XL-KRR-B-FA101	2,14	75	130	28	30,5	49,5	21,5	90	–
GE75-XL-KTT-B	2,14	75	130	28	30,5	49,5	21,5	90	–
GE80-XL-KRR-B	2,79	80	140	30	38	53,2	23,4	97	–
GE80-XL-KRR-B-AH01-FA164	2,95	80	140	30	38	53,2	23,4	97	–
GE80-XL-KTT-B	2,79	80	140	30	38	53,2	23,4	97	–
GNE80-XL-KRR-B <sup>4)</sup>	7,1	80	170	41	51	73	34	109	–
GE90-XL-KRR-B <sup>4)</sup>	3,56	90	160	32	35	52	23	109,4	–
GE90-XL-KRR-B-FA164 <sup>4)</sup>	3,68	90	160	32	35	52	23	109,4	–
GNE90-XL-KRR-B <sup>4)</sup>	8,07	90	190	45	52,6	77,5	35,5	122,2	–
GE100-XL-KRR-B <sup>4)</sup>	5	100	180	36	39	57,5	25,5	122,2	–
GNE100-XL-KRR-B <sup>4)</sup>	11,41	100	215	49	59,4	86	39,5	137,1	–
GE120-XL-KRR-B <sup>4)</sup>	7,49	120	215	40	45	63,5	28,5	146,4	–

1) Permissible speeds of radial insert ball bearings: see page 148.  
 2) Factor  $f_0$  for determining equivalent bearing load, see table, page 40.  
 3) Alternative ball set 6214.  
 4) Lubrication groove in outer ring.

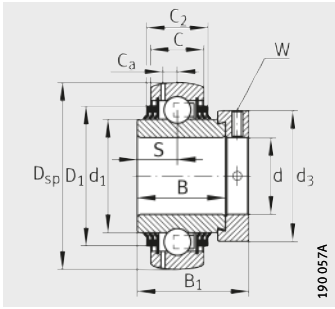

GE..-XL-KTT-B

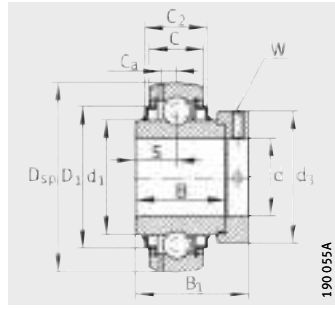

GNE..-XL-KRR-B



				Width across flats W	Basic load ratings		Fatigue limit load C <sub>ur</sub> N	Factor <sup>2)</sup> f <sub>0</sub>
D <sub>1</sub>	C <sub>a</sub>	B <sub>1</sub>	d <sub>3</sub> max.		dyn. C <sub>r</sub> N	stat. C <sub>0r</sub> N		
85,9	7	71,4	76	5	46 000	29 000	1 480	14,3
85,9	7	71,4	76	5	46 000	29 000	1 480	14,3
–	7	48,4	76	5	46 000	29 000	1 480	14,3
94,5	7,2	77,9	84	5	56 000	36 000	1 820	14,3
94,5	7,2	77,9	84	5	56 000	36 000	1 820	14,3
94,5	7,2	77,9	84	5	56 000	36 000	1 820	14,3
94,5	7,2	77,9	84	5	56 000	36 000	1 820	14,3
109	11,2	68	89	5	87 000	52 000	2 650	13,1
–	7,2	53,1	84	5	56 000	36 000	1 820	14,3
109	8,9	66	96	6	66 000	44 000	2 230	14,4
109	8,9	66	96	6	66 000	44 000	2 230	14,4
109	8,9	66	96	6	66 000	44 000	2 230	14,4
109	8,9	66	96	6	66 000	44 000	2 230	14,4
109	8,9	66	96	6	66 000	44 000	2 230	14,4
109	8,9	66	96	6	66 000	44 000	2 230	14,4
109	8,9	66	96	6	66 000	44 000	2 230	14,4
127	12	75,5	102	6	111 000	68 000	3 300	13,2
113	8,5	67	100	6	66 000	44 500	2 240	14,4
113	8,5	67	100	6	66 000	44 500	2 240	14,4
113	8,5	67	100	6	66 000	44 500	2 240	14,4
120	8,8	70,7	108	6	76 000	54 000	2 600	14,6
120	8,8	70,7	108	6	76 000	54 000	2 600	14,6
120	8,8	70,7	108	6	76 000	54 000	2 600	14,6
142,8	13,2	93,6	118	6	131 000	87 000	3 950	13,2
138	10	69,5	118	6	109 000	79 000	3 550	14,5
138	10	69,5	118	6	109 000	79 000	3 550	14,5
161,3	14,3	101	132	6	151 000	107 000	4 600	13,9
155,5	11,2	75	132	6	130 000	93 000	4 000	14,4
182,8	16,7	109,4	145	6	184 000	141 000	5 700	13,8
186,5	12,8	81	152	6	165 000	131 000	5 100	14,8

# Radial insert ball bearings with grub screws in inner ring

Spherical outer ring

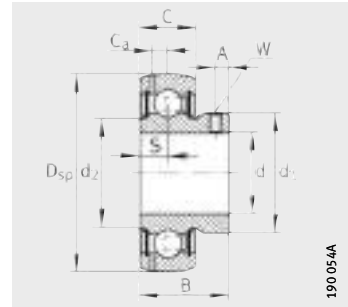

GAY..-XL-NPP-B, AY..-XL-NPP-B

X-life

**Dimension table** - Dimensions in mm

Designation <sup>1)</sup>	Mass m ≈ kg	Dimensions					
		d	D <sub>sp</sub>	C	C <sub>2</sub>	B	S
<b>GYE12-XL-KRR-B</b>	0,11	<b>12</b>	40	12	16,6	27,4	11,5
<b>AY12-XL-NPP-B</b>	0,1	<b>12</b>	40	12	–	22	6
<b>GAY12-XL-NPP-B</b>	0,1	<b>12</b>	40	12	–	22	6
<b>GAY12-XL-NPP-B-FA164</b>	0,1	<b>12</b>	40	12	–	22	6
<b>GYE15-XL-KRR-B</b>	0,1	<b>15</b>	40	12	16,6	27,4	11,5
<b>AY15-XL-NPP-B</b>	0,09	<b>15</b>	40	12	–	22	6
<b>GAY15-XL-NPP-B</b>	0,09	<b>15</b>	40	12	–	22	6
<b>GAY15-XL-NPP-B-FA164</b>	0,09	<b>15</b>	40	12	–	22	6
<b>GYE16-XL-KRR-B</b>	0,09	<b>16</b>	40	12	16,6	27,4	11,5
<b>GYE17-XL-KRR-B</b>	0,09	<b>17</b>	40	12	16,6	27,4	11,5
<b>AY17-XL-NPP-B</b>	0,08	<b>17</b>	40	12	–	22	6
<b>GAY17-XL-NPP-B</b>	0,08	<b>17</b>	40	12	–	22	6
<b>GYE20-XL-KRR-B</b>	0,14	<b>20</b>	47	14	16,6	31	12,7
<b>AY20-XL-NPP-B</b>	0,13	<b>20</b>	47	14	–	25	7
<b>GAY20-XL-NPP-B</b>	0,13	<b>20</b>	47	14	–	25	7
<b>GYE25-XL-KRR-B</b>	0,19	<b>25</b>	52	15	16,7	34,1	14,3
<b>AY25-XL-NPP-B</b>	0,16	<b>25</b>	52	15	–	27	7,5
<b>GAY25-XL-NPP-B</b>	0,16	<b>25</b>	52	15	–	27	7,5
<b>GYE30-XL-KRR-B</b>	0,31	<b>30</b>	62	18	20,7	38,1	15,9
<b>AY30-XL-NPP-B</b>	0,25	<b>30</b>	62	18	–	30	9
<b>GAY30-XL-NPP-B</b>	0,26	<b>30</b>	62	18	–	30	9
<b>GYE35-XL-KRR-B</b>	0,46	<b>35</b>	72	19	22,5	42,9	17,5
<b>GAY35-XL-NPP-B</b>	0,41	<b>35</b>	72	19	–	35	9,5

<sup>1)</sup> Permissible speeds of radial insert ball bearings: see page 148.

<sup>2)</sup> Factor  $f_0$  for determining equivalent bearing load, see table, page 40.



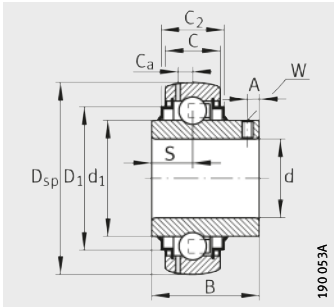

GYE...XL-KRR-B



					Width across flats W	Basic load ratings		Fatigue limit load C <sub>ur</sub> N	Factor <sup>2)</sup> f <sub>0</sub>
d <sub>1</sub>	d <sub>2</sub>	D <sub>1</sub>	C <sub>a</sub>	A		dyn. C <sub>r</sub> N	stat. C <sub>0r</sub> N		
23,9	-	31,6	3,4	4	2,5	10 100	4 750	241	13,1
23,9	22,9	-	-	4	2,5	10 100	4 750	241	13,1
23,9	22,9	-	3,4	4	2,5	10 100	4 750	241	13,1
23,9	22,9	-	3,4	4	2,5	10 100	4 750	241	13,1
23,9	-	31,6	3,4	4	2,5	10 100	4 750	241	13,1
23,9	22,9	-	-	4	2,5	10 100	4 750	241	13,1
23,9	22,9	-	3,4	4	2,5	10 100	4 750	241	13,1
23,9	22,9	-	3,4	4	2,5	10 100	4 750	241	13,1
23,9	-	31,6	3,4	4	2,5	10 100	4 750	241	13,1
23,9	-	31,6	3,4	4	2,5	10 100	4 750	241	13,1
23,9	22,9	-	-	4	2,5	10 100	4 750	241	13,1
23,9	22,9	-	3,4	4	2,5	10 100	4 750	241	13,1
27,6	-	37,4	4	4,5	2,5	13 600	6 600	335	13,1
28,3	26,7	-	-	4,5	2,5	13 600	6 600	335	13,1
28,3	26,7	-	4	4,5	2,5	13 600	6 600	335	13,1
33,8	-	42,5	3,9	5	2,5	14 900	7 800	395	13,8
33,5	30,4	-	-	5	2,5	14 900	7 800	395	13,8
33,5	30,4	-	3,9	5	2,5	14 900	7 800	395	13,8
40,2	-	52	4,7	5,8	3	20 700	11 300	570	13,8
39,4	37,3	-	-	5,8	3	20 700	11 300	570	13,8
39,4	37,3	-	4,7	5,8	3	20 700	11 300	570	13,8
46,8	-	60,3	5,6	6	3	27 500	15 300	770	13,8
46,9	44,5	-	5,6	6	3	27 500	15 300	770	13,8

# Radial insert ball bearings with grub screws in inner ring

Spherical outer ring

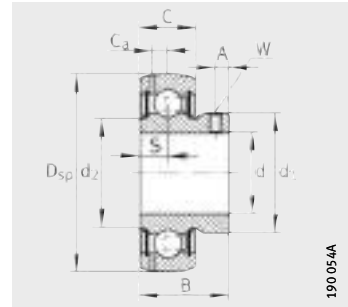

GAY...XL-NPP-B

X-life

**Dimension table** (continued) · Dimensions in mm

Designation <sup>1)</sup>	Mass m ≈ kg	Dimensions					
		d	D <sub>sp</sub>	C	C <sub>2</sub>	B	S
<b>GYE40-XL-KRR-B</b>	0,62	<b>40</b>	80	21	23,5	49,2	19
<b>GAY40-XL-NPP-B</b>	0,53	<b>40</b>	80	21	–	39,5	10,5
<b>GYE45-210-XL-KRR-B<sup>3)</sup></b>	0,8	<b>45</b>	90	22	26,4	51,6	19
<b>GYE45-XL-KRR-B</b>	0,71	<b>45</b>	85	22	26,4	49,2	19
<b>GAY45-XL-NPP-B</b>	0,6	<b>45</b>	85	22	–	41,5	11
<b>GYE50-XL-KRR-B</b>	0,79	<b>50</b>	90	22	26,4	51,6	19
<b>GAY50-XL-NPP-B</b>	0,67	<b>50</b>	90	22	–	43	11
<b>GYE55-XL-KRR-B</b>	1,08	<b>55</b>	100	25	29	55,6	22,2
<b>GYE60-XL-KRR-B</b>	1,46	<b>60</b>	110	24	29	65,1	25,4
<b>GAY60-XL-NPP-B</b>	1,17	<b>60</b>	110	24	–	47	13
<b>GYE65-214-XL-KRR-B<sup>4)</sup></b>	2,25	<b>65</b>	125	28	32	74,6	30,2
<b>GYE70-XL-KRR-B</b>	1,95	<b>70</b>	125	28	32	74,6	30,2
<b>GYE75-XL-KRR-B</b>	2,07	<b>75</b>	130	28	30,5	77,8	33,3
<b>GYE80-XL-KRR-B</b>	2,7	<b>80</b>	140	30	38	82,6	33,3
<b>GYE90-XL-KRR-B<sup>5)</sup></b>	3,93	<b>90</b>	160	32	35	96	39,7

<sup>1)</sup> Permissible speeds of radial insert ball bearings: see page 148.

<sup>2)</sup> Factor  $f_0$  for determining equivalent bearing load, see table, page 40.

<sup>3)</sup> Alternative ball set 6210.

<sup>4)</sup> Alternative ball set 6214.

<sup>5)</sup> Lubrication groove in outer ring.

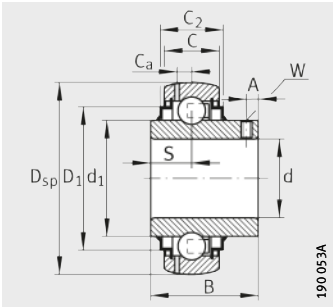

GYE...XL-KRR-B



					Width across flats W	Basic load ratings		Fatigue limit load C <sub>ur</sub> N	Factor <sup>2)</sup> f <sub>0</sub>
d <sub>1</sub>	d <sub>2</sub>	D <sub>1</sub>	C <sub>a</sub>	A		dyn. C <sub>r</sub> N	stat. C <sub>0r</sub> N		
52,3	–	68,3	6,4	8	4	34 500	19 800	1 010	14
52,4	49,3	–	6,4	8	4	34 500	19 800	1 010	14
62,9	–	77,3	6,9	8,5	4	37 500	23 200	1 180	14,3
57	–	72,3	6,4	8	4	34 500	20 400	1 030	14,3
57	54,3	–	6,4	8	4	34 500	20 400	1 030	14,3
62,8	–	77,3	6,9	8,5	4	37 500	23 200	1 180	14,3
62	59,3	–	6,9	9	4	37 500	23 200	1 180	14,3
69,8	–	85,9	7	9	4	46 000	29 000	1 480	14,3
76,5	–	94,5	7,2	10,1	5	56 000	36 000	1 820	14,3
76	73,6	–	7,2	10	5	56 000	36 000	1 820	14,3
85,2	–	109	8,9	12,1	5	66 000	44 000	2 230	14,4
85,2	–	109	8,9	12	5	66 000	44 000	2 230	14,4
90	–	113	8,5	12,7	5	66 000	44 500	2 240	14,7
97	–	120	8,8	12	5	76 000	54 000	2 600	14,6
109,4	–	138	10	12	6	109 000	79 000	3 550	14,6

# Radial insert ball bearings with adapter sleeve

Spherical outer ring

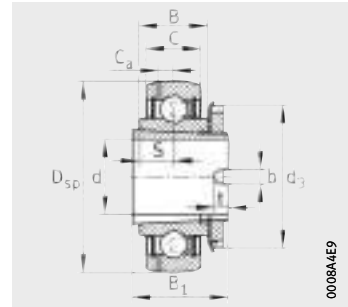

GSH...-XL-2RSR-B



**Dimension table** - Dimensions in mm

Designation	Mass m ≈ kg	Dimensions						
		d	D <sub>sp</sub>	C	B	S	C <sub>a</sub>	B <sub>1</sub>
<b>GSH20-XL-2RSR-B</b>	0,14	<b>20</b>	47	14	15	7,5	4	28
<b>GSH25-XL-2RSR-B</b>	0,17	<b>25</b>	52	15	15	7,5	3,9	28
<b>GSH30-XL-2RSR-B</b>	0,27	<b>30</b>	62	18	18	9	4,7	32
<b>GSH35-XL-2RSR-B</b>	0,43	<b>35</b>	72	19	19	9,5	5,8	34
<b>GSH40-XL-2RSR-B</b>	0,54	<b>40</b>	80	21	22	11	6,4	38
<b>GSH45-XL-2RSR-B</b>	0,69	<b>45</b>	85	22	36	18	6,4	46
<b>GSH50-XL-2RSR-B</b>	0,64	<b>50</b>	90	22	22	11	6,5	40

<sup>1)</sup> Preferably for shafts of tolerance classes h6 © to h11 ©.

<sup>2)</sup> Factor  $f_0$  for determining equivalent bearing load, see table, page 40.



			Limiting speed <sup>1)</sup> n <sub>G grease</sub> min <sup>-1</sup>	Basic load ratings		Fatigue limit load C <sub>ur</sub> N	Factor <sup>2)</sup> f <sub>0</sub>
b	t	d <sub>3</sub> max.		dyn. C <sub>r</sub> N	stat. C <sub>0r</sub> N		
5	5	32	8 700	13 400	7 000	355	13,1
5	5	38	7 500	14 400	8 100	410	13,8
5	5	45	6 200	20 100	11 600	590	13,8
5	5	52	5 500	26 500	15 700	800	13,8
5	5	58	4 850	31 000	19 700	1 000	14
5	5	62	4 500	31 000	20 100	1 020	14,3
5	5	70	4 150	35 000	23 100	1 170	14,3

# Radial insert ball bearings with drive slot

Non-locating bearings  
Spherical outer ring

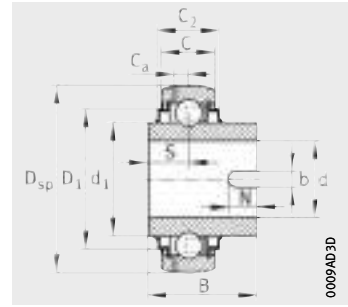

GLE..-XL-KRR-B



**Dimension table** - Dimensions in mm

Designation <sup>1)</sup>	Mass m ≈ kg	Dimensions						
		d	D <sub>sp</sub>	C	C <sub>2</sub>	B	S	d <sub>1</sub>
<b>GLE20-XL-KRR-B</b>	0,15	<b>20</b>	47	14	16,6	34,1	15,6	27,6
<b>GLE25-XL-KRR-B</b>	0,19	<b>25</b>	52	15	16,7	34,9	14,7	33,8
<b>GLE30-XL-KRR-B</b>	0,3	<b>30</b>	62	18	20,7	36,5	14,5	40,2
<b>GLE35-XL-KRR-B</b>	0,43	<b>35</b>	72	19	22,5	37,7	15,7	46,8
<b>GLE40-XL-KRR-B</b>	0,57	<b>40</b>	80	21	23,5	42,9	15,9	52,3
<b>GLE45-XL-KRR-B</b>	0,66	<b>45</b>	85	22	26,4	42,9	17,4	57,9
<b>GLE50-XL-KRR-B</b>	0,76	<b>50</b>	90	22	26,4	49,2	19	62,8
<b>GLE60-XL-KRR-B</b>	1,46	<b>60</b>	110	24	29	61,9	24,6	76,5
<b>GLE70-XL-KRR-B</b>	1,9	<b>70</b>	125	28	32	68,2	27	85,2

<sup>1)</sup> Permissible speeds of radial insert ball bearings: see page 148.

<sup>2)</sup> Factor  $f_0$  for determining equivalent bearing load, see table, page 40.



				Basic load ratings		Fatigue limit load C <sub>ur</sub> N	Factor <sup>2)</sup> f <sub>0</sub>
D <sub>1</sub>	C <sub>a</sub>	N	b H11	dyn. C <sub>r</sub> N	stat. C <sub>0r</sub> N		
37,4	4	7	7	13 600	6 600	335	13,1
42,5	3,9	8	7	14 900	7 800	395	13,8
52	4,7	8	7	20 700	11 300	570	13,8
60,3	5,6	8	7	27 500	15 300	770	13,8
68,3	6,4	9	7	34 500	19 800	1 010	14
72,3	6,4	9	7	34 500	20 400	1 030	14,3
77,3	6,9	10	7	37 500	23 200	1 180	14,3
95,9	7,2	12	9	56 000	36 000	1 820	14,3
109	8,9	12	9	66 000	44 000	2 230	14,4

# Self-aligning deep groove ball bearings

Spherical outer ring  
Bore for fit

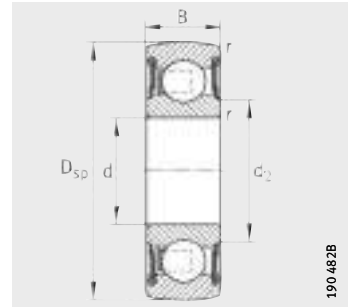

2..-XL-NPP-B



190.4828

**Dimension table** - Dimensions in mm

Designation	Mass m ≈ kg	Dimensions					Limiting speed $n_G$ grease $\text{min}^{-1}$	Basic load ratings		Fatigue limit load $C_{ur}$ N	Factor <sup>1)</sup> $f_0$
		d	$D_{sp}$	B	$d_2$	$r_{min}$		dyn. $C_r$ N	stat. $C_{Or}$ N		
<b>201-XL-NPP-B<sup>2)</sup></b>	0,04	<b>12</b>	32	10	17,1	0,6	14 600	7 200	3 050	154	12,3
<b>203-XL-NPP-B<sup>3)</sup></b>	0,06	<b>17</b>	40	12	22,5	0,6	11 100	10 100	4 750	241	13,1
<b>204-XL-NPP-B<sup>3)</sup></b>	0,11	<b>20</b>	47	14	26,5	1	9 300	13 600	6 600	335	13,1
<b>205-XL-NPP-B<sup>3)</sup></b>	0,13	<b>25</b>	52	15	30,3	1	8 000	14 900	7 800	395	13,8
<b>206-XL-NPP-B<sup>2)</sup></b>	0,2	<b>30</b>	62	16	37,4	1	6 700	20 700	11 300	570	13,8
<b>207-XL-NPP-B<sup>2)</sup></b>	0,29	<b>35</b>	72	17	42,4	1	5 700	27 500	15 300	770	13,8
<b>208-XL-NPP-B<sup>2)</sup></b>	0,37	<b>40</b>	80	18	48,4	1,1	5 000	34 500	19 800	1 010	14
<b>209-XL-NPP-B<sup>2)</sup></b>	0,41	<b>45</b>	85	19	53,2	1,1	4 650	34 500	20 400	1 030	14,3
<b>210-XL-NPP-B<sup>3)</sup></b>	0,46	<b>50</b>	90	20	58,2	1,1	4 300	37 500	23 200	1 180	14,3

1) Factor  $f_0$  for determining equivalent bearing load, see table, page 40.

2) One-piece seal with moulded seal lip.

3) Three-piece P seal.





# Self-aligning deep groove ball bearings

Spherical outer ring  
Square bore

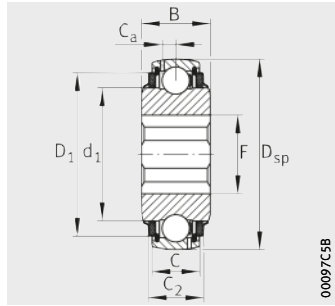

GVK(E)..-KTT-B(-AS2/V)(-AH)

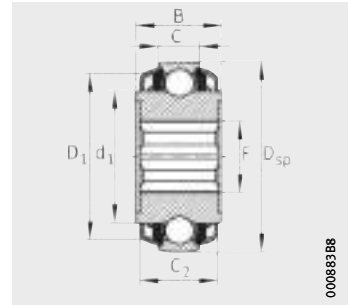

VKE..-KTT-B-2C

**Dimension table** - Dimensions in mm

Width across flats of shaft d		Designation	Mass m ≈ kg	Dimensions					
				d	D <sub>sp</sub>	C	C <sub>2</sub>	d <sub>1</sub>	
inch	mm								
–	16,3	GVKE16-205-KRR-B-AS2/V-AH01	0,22	16,3	+0,2 0	52	15	16,5	33,8
		GVKE16-205-KRR-B-2C-AS2/V-AH01	0,24	16,3	+0,2 0	52	15	24,8 <sup>2)</sup>	33,8
1	25,4	VK100-208-KTT-B-AH10	0,67	25,4	+0,9 +0,6	80	18	25,2	52,3
		GVK100-208-KTT-B-AS2/V	0,74	25,4	+0,9 +0,6	80	21	28,1	52,3
–	28	VKE28-209-KTT-B-GA47/70	0,89	28	+0,9 +0,6	85	22	25,4	57,9
1 <sup>1</sup> / <sub>8</sub>	28,575	GVK102-208-KTT-B-AH10	0,62	28,575	+0,9 +0,6	80	18	25	52,3
–	30	VKE30-212-KTT-B-2C	2,02	30	+0,13 0	110	24	45,4 <sup>2)</sup>	74,8
		GVKE30-211-KTT-B-AS2/V	1,23	30	+0,9 +0,6	100	25	27,4	69,7
1 <sup>1</sup> / <sub>4</sub>	31,75	GVK104-209-KTT-B	0,72	31,75	+0,9 +0,6	85	22	26,3	57,9
–	38	VKE38-211-KTT-B-GA47/70-AH01	1,42	38	+0,9 +0,6	100	25	27,4	69,7
1 <sup>1</sup> / <sub>2</sub>	38,1	GVK108-211-KTT-B-AS2/V	1,08	38,1	+0,9 +0,6	100	25	27,4	69,7
1 <sup>9</sup> / <sub>16</sub>	39,6875	GVK109-211-KTT-B	1,07	39,6875	+0,3 0	100	25	28,9	69,8

1) Factor  $f_0$  for determining equivalent bearing load, see table, page 40.

2) Dimension for flinger shield.

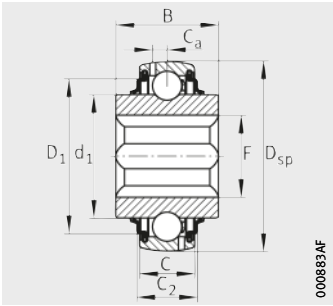

GVKE...KRR-B-AS2/V-AH

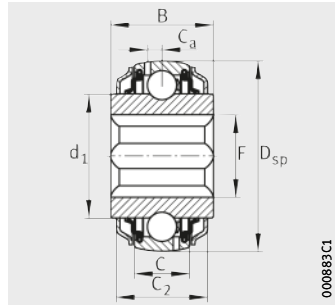

GVKE...KRR-B-2C-AS2/V-AH

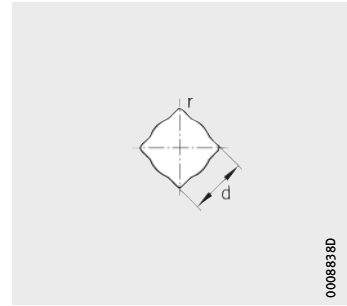

Design of bore



F	D <sub>1</sub>	C <sub>a</sub>	B	r	Basic load ratings		Fatigue limit load C <sub>ur</sub> N	Factor <sup>1)</sup> f <sub>0</sub>	Width across flats of shaft d	
					dyn. C <sub>r</sub> N	stat. C <sub>0r</sub> N			inch	mm
					22,4	42,5	3,9	28	0,7	14 900
22,4	–	3,9	28	0,7	14 900	7 800	395	13,8	–	
33,8	68,4	–	36,5	2,5	34 500	19 800	1 010	14	<b>1</b>	<b>25,4</b>
35,4	68,3	6,4	36,5	2,5	34 500	19 800	1 010	14		
37,5	71,7	–	42,9	2,5	34 500	20 400	1 030	14,3	–	<b>28</b>
38,3	67,8	5,8	36,5	2,5	34 500	19 800	1 010	14	<b>1<sup>1</sup>/<sub>8</sub></b>	<b>28,575</b>
41,2	–	–	49,2	2,5	56 000	36 000	1 820	14,3	–	<b>30</b>
40,3	85,3	7,1	36	2,5	46 000	29 000	1 480	14,3		
36,4	72,2	6,4	36,5	2,5	34 500	20 400	1 030	14,3	<b>1<sup>1</sup>/<sub>4</sub></b>	<b>31,75</b>
51,8	85,3	–	55,2	2,5	46 000	29 000	1 480	14,3	–	<b>38</b>
43,9	85,3	7,1	36	2,5	46 000	29 000	1 480	14,3	<b>1<sup>1</sup>/<sub>2</sub></b>	<b>38,1</b>
55,1	85,8	7	36	2,5	46 000	29 000	1 480	14,3	<b>1<sup>9</sup>/<sub>16</sub></b>	<b>39,6875</b>

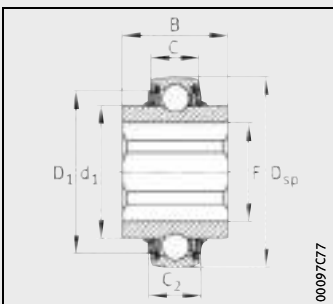

VK...-KTT-B(-AH),  
VKE...-KTT-B-G47/70(-AH)

# Self-aligning deep groove ball bearings

Spherical outer ring  
Hexagonal bore

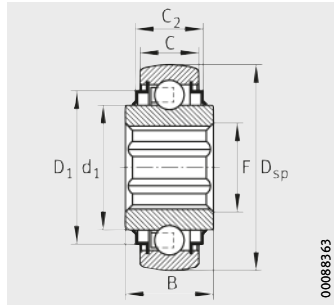

SK...KRR-B(-L402/70)(-AH),  
SKE...KRR-B

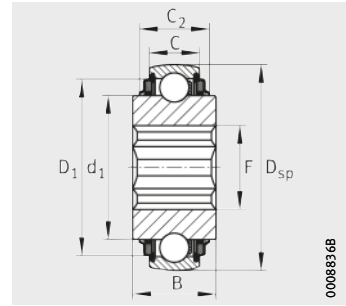

SK...KTT-B(-L402/70)(-AH)

**Dimension table** - Dimensions in mm

Width across flats of shaft d		Designation	Mass m ≈ kg	Dimensions					
				d	D <sub>sp</sub>	C	C <sub>2</sub>	d <sub>1</sub>	
inch	mm								
–	16,1	SK010-204-KRR-B	0,12	16,1 <sup>+0,15</sup> <sub>+0,05</sub>	47	14	–	27,6	
–	17	SKE17-204-KRR-B	0,12	17 <sup>+0,15</sup> <sub>+0,05</sub>	47	14	–	28,7	
7/8	22,225	SK014-205-KRR-B	0,2	22,225 <sup>+0,15</sup> <sub>+0,05</sub>	52	15	16,7	33,8	
		SK014-205-KTT-B-L402/70	0,18	22,225 <sup>+0,15</sup> <sub>+0,05</sub>	52	15	19	33,8	
1	25,4	SK100-206-KRR-B-AH11	0,32	25,4 <sup>+0,15</sup> <sub>+0,03</sub>	62	16	18,7	40,2	
1 1/8	28,575	SK102-207-KRR-B-L402/70-AH11	0,38	28,575 <sup>+0,13</sup> <sub>0</sub>	72	17	18,7	46,8	
		SK102-207-KRR-B-AH10	0,45	28,575 <sup>+0,175</sup> <sub>+0,03</sub>	72	17	20,5	46,8	
1 1/4	31,75	SK104-207-KRR-B-L402/70-AH12	0,35	31,75 <sup>+0,15</sup> <sub>+0,05</sub>	72	17	18,7	46,8	
		SK104-208-KTT-B-AH10	0,65	31,75 <sup>+0,15</sup> <sub>+0,05</sub>	80	18	25	52,3	
		SK104-208-KTT-B-L402/70-AH10	0,6	31,75 <sup>+0,15</sup> <sub>+0,05</sub>	80	18	25	52,3	
		SK104-207-KTT-B-L402/70	0,45	31,75 <sup>+0,15</sup> <sub>+0,05</sub>	72	19	22,7	46,8	
		SK104-207-KTT-B	0,48	31,75 <sup>+0,15</sup> <sub>+0,05</sub>	72	19	23,7	46,8	
		SK104-210-KTT-B-L402/70	0,98	31,75 <sup>+0,15</sup> <sub>+0,05</sub>	90	22	25,5	62,8	
1 3/8	34,925	SK106-208-KRR-B-L402/70	0,59	34,925 <sup>+0,15</sup> <sub>0</sub>	80	20,9	22,4	52,3	
1 1/2	38,1	SK108-209-KRR-B-L402/70-AH11	0,59	38,1 <sup>+0,12</sup> <sub>0</sub>	85	19	23,9	57,9	
		SK108-210-KRR-B	0,78	38,1 <sup>+0,12</sup> <sub>0</sub>	90	22	26	62,8	
		SK108-210-KRR-B-AH01	0,75	38,1 <sup>+0,1</sup> <sub>0</sub>	90	22	27,1	62,8	

<sup>1)</sup> Factor  $f_0$  for determining equivalent bearing load, see table, page 40.

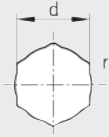

00088367

Design of bore



				Basic load ratings		Fatigue limit load $C_{ur}$ N	Factor <sup>1)</sup> $f_0$	Width across flats of shaft d			
F	$D_1$	B	r	dyn. $C_r$ N	stat. $C_{Or}$ N			inch	mm		
19,7	–	17,7	0,13	13 600	6 600	335	13,1	–	<b>16,1</b>		
20,2	–	17,7	0,13	13 600	6 600	335	13,1	–	<b>17</b>		
26,2	42,6	25,4	0,13	14 900	7 800	395	13,8	$7/8$	<b>22,225</b>		
26,6	42,5	25,4	0,12	14 900	7 800	395	13,8				
30,5	52	24	0,13	20 700	11 300	570	13,8	<b>1</b>	<b>25,4</b>		
34,2	60	25	0,25	27 500	15 300	770	13,8	$1\frac{1}{8}$	<b>28,575</b>		
38	60,3	37,7	0,25	27 500	15 300	770	13,8				
38	60	25	0,12	27 500	15 300	770	13,8	$1\frac{1}{4}$	<b>31,75</b>		
38	68,4	36,5	0,12	34 500	19 800	1 010	14				
38	68,4	36,5	0,12	34 500	19 800	1 010	14				
37,2	60	37,9	0,13	27 500	15 300	770	13,8				
38	60	37,9	0,12	27 500	15 300	770	13,8				
36,8	77,2	36,5	0,12	37 500	23 200	1 180	14,3				
41,5	67,7	36,5	0,12	34 500	19 800	1 010	14			$1\frac{3}{8}$	<b>34,925</b>
45,1	71,7	30	0,13	34 500	20 400	1 030	14,3				
43,6	76,7	30	0,13	37 500	23 200	1 180	14,3				
43,7	77,2	32	0,13	37 500	23 200	1 180	14,3				

# Inch size radial insert ball bearings

Spherical outer ring

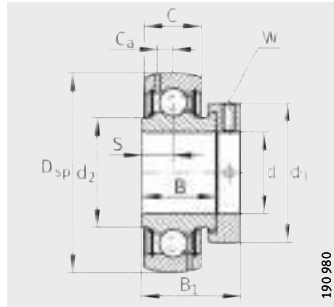

GRA...-NPP-B-AS2/V

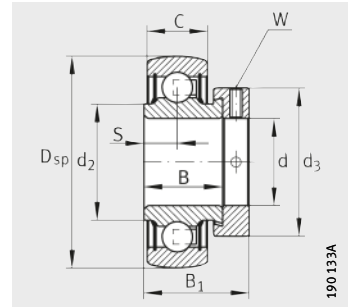

RA...-NPP-B

**Dimension table** - Dimensions in mm

Shaft diameter		Designation <sup>1)</sup>	Mass	Dimensions						
				D <sub>sp</sub>	C	C <sub>2</sub>	B	S	d <sub>1</sub>	d <sub>2</sub>
inch	mm		m							
1/2	12,7	GY1008-KRR-B-AS2/V	0,11	40	12	–	27,3	11,5	23,9	–
5/8	15,875	GRA010-NPP-B-AS2/V	0,11	40	12	–	19	6,5	–	23
		GAY010-NPP-B-AS2/V	0,09	40	12	–	22	6	23	23
		GY1010-KRR-B-AS2/V	0,1	40	12	–	27,3	11,5	23,9	–
		G1010-KRR-B-AS2/V	0,13	40	12	–	27,7	13,9	23,9	–
3/4	19,05	GRA012-NPP-B-AS2/V	0,16	47	14	–	21,4	7,5	–	26,9
		GAY012-NPP-B-AS2/V	0,13	47	14	–	25	7	27,8	26,9
		GY1012-KRR-B-AS2/V	0,15	47	14	16,2	31	12,7	27,6	–
		G1012-KRR-B-AS2/V	0,21	47	14	16,2	34,1	17,1	27,6	–
7/8	22,225	GRA014-NPP-B-AS2/V	0,21	52	15	–	21,4	7,5	–	30,3
		GY1014-KRR-B-AS2/V	0,21	52	15	16,5	34,1	14,3	33,8	–
		G1014-KRR-B-AS2/V	0,27	52	15	16,5	34,9	17,5	33,8	–
15/16	23,8125	GY1015-KRR-B-AS2/V	0,2	52	15	16,5	34,1	14,3	33,8	–
		G1015-KRR-B-AS2/V	0,25	52	15	16,5	34,9	17,5	33,8	–
1	25,4	RA100-NPP-B	0,19	52	15	–	21,4	7,5	–	30,5
		GRA100-NPP-B-AS2/V	0,18	52	15	–	21,4	7,5	–	30,3
		GAY100-NPP-B-AS2/V	0,15	52	15	–	27	7,5	33,6	30,4
		GY1100-KRR-B-AS2/V	0,18	52	15	16,5	34,1	14,3	33,8	–
		G1100-KRR-B-AS2/V	0,23	52	15	16,5	34,9	17,5	33,8	–

<sup>1)</sup> Permissible speeds of radial insert ball bearings: see page 148.

<sup>2)</sup> Factor  $f_0$  for determining equivalent bearing load, see table, page 40.

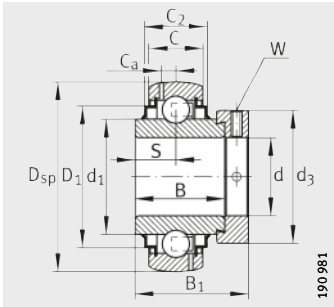

G...KRR-B-AS2/V

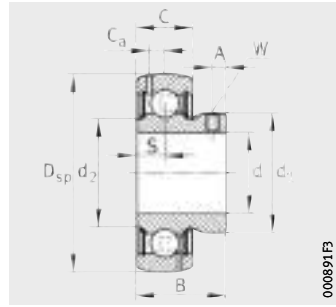

GAY...NPP-B(-AS2/V)

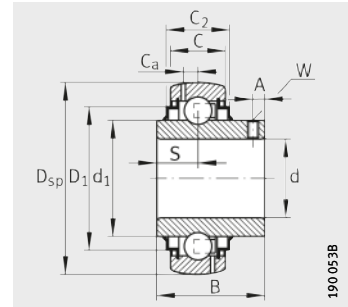

GY...KRR-B-AS2/V



D <sub>1</sub>	C <sub>a</sub>	B <sub>1</sub>	d <sub>3</sub>	A	Width across flats W	Basic load ratings		Fatigue limit load C <sub>ur</sub>	Factor <sup>2)</sup> f <sub>0</sub>	Shaft diameter	
						dyn. C <sub>r</sub>	stat. C <sub>0r</sub>			d	
					inch	N	N	N	inch	mm	
-	3,4	-	-	4	3/32	10 100	4 750	241	13,1	1/2	12,7
-	3,4	28,6	28	-	1/8	10 100	4 750	241	13,1	5/8	15,875
-	3,4	-	-	4	3/32	10 100	4 750	241	13,1		
-	3,4	-	-	4	3/32	10 100	4 750	241	13,1		
-	3,4	37,3	28	-	1/8	10 100	4 750	241	13,1		
-	3,9	31	33	-	1/8	13 600	6 600	335	13,1	3/4	19,05
-	3,9	-	-	4,5	3/32	13 600	6 600	335	13,1		
37,4	3,9	-	-	4,5	3/32	13 200	6 100	310	13,1		
37,4	3,9	43,7	33	-	1/8	13 600	6 600	335	13,1		
-	3,9	31	37,5	-	1/8	14 900	7 800	395	13,8	7/8	22,225
42,5	3,9	-	-	4,9	3/32	14 900	7 800	395	13,8		
42,5	3,9	44,5	37,5	-	1/8	14 900	7 800	395	13,8		
42,5	3,9	-	-	4,9	3/32	14 900	7 800	395	13,8		
42,5	3,9	44,5	37,5	-	1/8	14 900	7 800	395	13,8	1	25,4
-	-	31	37,5	-	1/8	14 900	7 800	395	13,8		
-	3,9	31	37,5	-	1/8	14 900	7 800	395	13,8		
-	3,9	-	-	5	3/32	14 900	7 800	395	13,8		
42,5	3,9	-	-	5	3/32	14 900	7 800	395	13,8		
42,5	3,9	44,5	37,5	-	1/8	14 900	7 800	395	13,8		

# Inch size radial insert ball bearings

Spherical outer ring

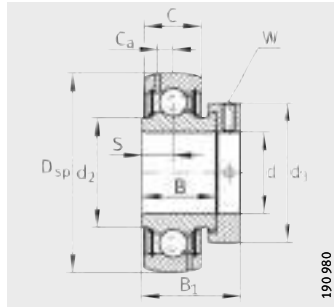

GRA...NPP-B-AS2/V

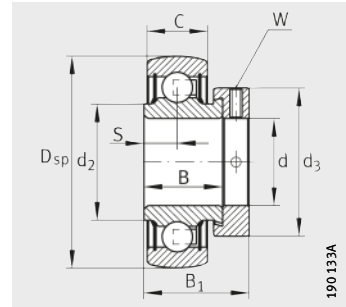

RA...NPP-B

**Dimension table** (continued) · Dimensions in mm

Shaft diameter		Designation <sup>1)</sup>	Mass	Dimensions						
				D <sub>sp</sub>	C	C <sub>2</sub>	B	S	d <sub>1</sub>	d <sub>2</sub>
inch	mm		m							
			≈ kg							
1 <sup>1</sup> / <sub>8</sub>	28,575	GRA102-NPP-B-AS2/V	0,32	62	18	–	23,8	9	–	37,3
		G1102-KRR-B-AS2/V	0,4	62	18	20,7	36,5	18,3	40,2	–
		GY1102-KRR-B-AS2/V	0,32	62	18	20	38,1	15,9	40,2	–
1 <sup>3</sup> / <sub>16</sub>	30,1625	GRA103-NPP-B-AS2/V	0,3	62	18	–	23,8	9	–	37,3
		G1103-KRR-B-AS2/V	0,37	62	18	20,7	36,5	18,3	40,2	–
		GY1103-KRR-B-AS2/V	0,3	62	18	20	38,1	15,9	40,2	–
1 <sup>1</sup> / <sub>4</sub>	31,75	RA104-206-NPP-B	0,31	62	18	–	23,8	9	–	37,4
		GRA104-206-NPP-B-AS2/V	0,28	62	18	–	23,8	9	–	37,3
		G1104-206-KRR-B-AS2/V	0,34	62	18	20,7	36,5	18,3	40,2	–
		GY1104-206-KRR-B-AS2/V	0,27	62	18	20	38,1	15,9	40,2	–
		RA104-NPP-B	0,48	72	19	–	25,4	9,5	–	44,6
		GRA104-NPP-B-AS2/V	0,5	72	19	–	25,4	9,5	–	44,5
		GAY104-NPP-B-AS2/V <sup>3)</sup>	0,44	72	19	–	35	9,5	47,1	44,5
		G1104-KRR-B-AS2/V	0,65	72	19	22,5	37,7	18,8	46,8	–
		GY1104-KRR-B-AS2/V	0,5	72	19	20,7	42,9	17,5	46,8	–
1 <sup>3</sup> / <sub>8</sub>	34,925	GRA106-NPP-B-AS2/V	0,45	72	19	–	25,4	9,5	–	44,5
		G1106-KRR-B-AS2/V	0,54	72	19	22,5	37,7	18,8	46,8	–
		GY1106-KRR-B-AS2/V	0,45	72	19	20,7	42,9	17,5	46,8	–
1 <sup>7</sup> / <sub>16</sub>	36,5125	GRA107-NPP-B-AS2/V	0,43	72	19	–	25,4	9,5	–	44,5
		GAY107-NPP-B-AS2/V	0,37	72	19	–	35	9,5	47,1	44,5
		G1107-KRR-B-AS2/V	0,5	72	19	20,7	37,7	18,8	46,8	–
		GY1107-KRR-B-AS2/V	0,42	72	19	20,7	42,9	17,5	46,8	–

<sup>1)</sup> Permissible speeds of radial insert ball bearings: see page 148.

<sup>2)</sup> Factor  $f_0$  for determining equivalent bearing load, see table, page 40.

<sup>3)</sup> Available by agreement.



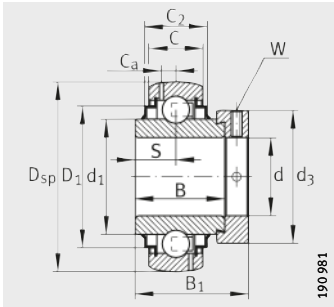

G...KRR-B-AS2/V

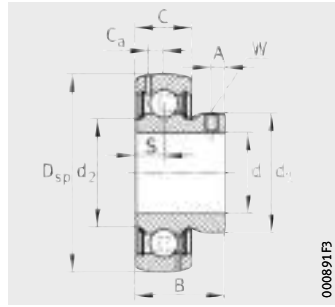

GAY...NPP-B-AS2/V

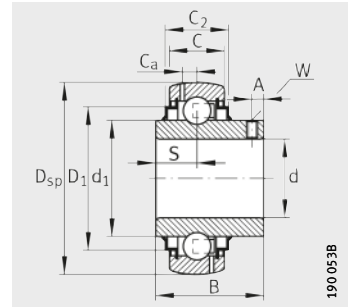

GY...KRR-B-AS2/V



					Width across flats W inch	Basic load ratings		Fatigue limit load C <sub>ur</sub> N	Factor <sup>2)</sup> f <sub>0</sub>	Shaft diameter d	
D <sub>1</sub>	C <sub>a</sub>	B <sub>1</sub>	d <sub>3</sub>	A		dyn. C <sub>r</sub> N	stat. C <sub>0r</sub> N			inch	mm
-	5	35,8	44	-	5/32	20 700	11 300	570	13,8	1 1/8	28,575
52	5	48,5	44	-	5/32	20 700	11 300	570	13,8		
51,8	5	-	-	5,6	1/8	20 700	11 300	570	13,8		
-	4,9	35,8	44	-	5/32	20 700	11 300	570	13,8	1 3/16	30,1625
52	5	48,35	44	-	5/32	20 700	11 300	570	13,8		
51,8	5	-	-	5,6	1/8	20 700	11 300	570	13,8		
-	-	35,8	44	-	5/32	20 700	11 300	570	13,8	1 1/4	31,75
-	5	35,8	44	-	5/32	20 700	11 300	570	13,8		
52	5	48,5	44	-	5/32	20 700	11 300	570	13,8		
51,8	5	-	-	5,6	1/8	20 700	11 300	570	13,8		
-	-	39	51	-	3/16	27 500	15 300	770	13,8		
-	5,7	39	51	-	3/16	27 500	15 300	770	13,8		
-	5,7	-	-	8	1/8	27 500	15 300	770	13,8		
60,3	5,7	51,3	51	-	5/32	27 500	15 300	770	13,8		
60,2	5,7	-	-	5,9	1/8	27 500	15 300	770	13,8		
-	5,7	39	51	-	3/16	27 500	15 300	770	13,8		
60,3	5,7	51,3	51	-	3/16	27 500	15 300	770	13,8		
60	5,7	-	-	7,9	1/8	27 500	15 300	770	13,8		
-	5,7	39	51	-	3/16	27 500	15 300	770	13,8	1 7/16	36,5125
-	5,7	-	-	8	1/8	27 500	15 300	770	13,8		
60,3	5,7	51,3	51	-	3/16	27 500	15 300	770	13,8		
60	5,7	-	-	6	1/8	27 500	15 300	770	13,8		

# Inch size radial insert ball bearings

Spherical outer ring

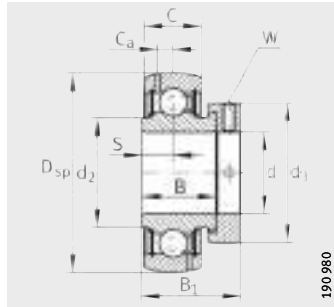

GRA...NPP-B-AS2/V

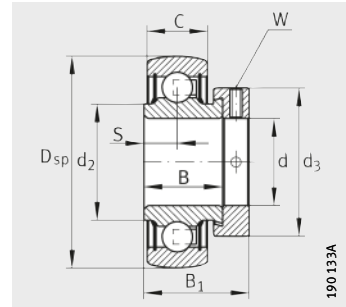

RA...NPP-B

**Dimension table** (continued) · Dimensions in mm

Shaft diameter		Designation <sup>1)</sup>	Mass	Dimensions						
				D <sub>sp</sub>	C	C <sub>2</sub>	B	S	d <sub>1</sub>	d <sub>2</sub>
inch	mm		m							
1 <sup>1</sup> / <sub>2</sub>	38,1	RA108-NPP-B	0,62	80	21	–	30,2	11	–	49,4
		GRA108-NPP-B-AS2/V	0,64	80	21	–	30,2	11	–	49,3
		G1108-KRR-B-AS2/V	0,76	80	21	22,5	42,9	21,4	52,3	–
1 <sup>5</sup> / <sub>8</sub>	41,275	G1110-KRR-B-AS2/V	0,9	85	22	25,7	42,9	21,4	57,9	–
1 <sup>11</sup> / <sub>16</sub>	42,8625	G1111-KRR-B-AS2/V	0,85	85	22	25,7	42,9	21,4	57,9	–
1 <sup>3</sup> / <sub>4</sub>	44,45	G1112-KRR-B-AS2/V	0,81	85	22	25,7	42,9	21,4	57,9	–
		GY1112-KRR-B-AS2/V	0,68	85	22	25,7	49,2	19	57,9	–
1 <sup>15</sup> / <sub>16</sub>	49,2125	GRA115-NPP-B-AS2/V <sup>3)</sup>	0,75	90	22	–	30,2	11	–	59,3
		G1115-KRR-B-AS2/V	1,01	90	22	26,1	49,2	24,6	62,8	–
		GY1115-KRR-B-AS2/V	0,82	90	22	26	51,6	19	62,8	–
2	50,8	G1200-KRR-B-AS2/V	1,51	100	25	28,4	55,5	27,8	69,8	–
		GY1200-KRR-B-AS2/V	1,18	100	25	28,4	55,6	22,2	69,8	–
2 <sup>3</sup> / <sub>16</sub>	55,5625	G1203-KRR-B-AS2/V	1,28	100	25	28,4	55,5	27,8	69,8	–
		GY1203-KRR-B-AS2/V	1,01	100	25	28,4	55,5	22,2	69,8	–
2 <sup>7</sup> / <sub>16</sub>	61,912	G1207-KRR-B-AS2/V	1,59	110	24	29,3	61,9	31	76,5	–
2 <sup>15</sup> / <sub>16</sub>	74,6125	G1215-KRR-B-AS2/V	2,09	130	28	30,5	49,5	21,5	99	–
		GY1215-KRR-B-AS2/V	2,01	130	28	31,5	77,8	33,4	90	–

1) Permissible speeds of radial insert ball bearings: see page 148.

2) Factor  $f_0$  for determining equivalent bearing load, see table, page 40.

3) Available by agreement.

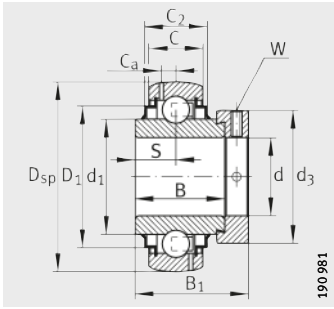

G...KRR-B-AS2/V

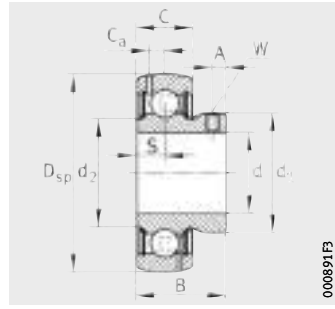

GAY...NPP-B-AS2/V

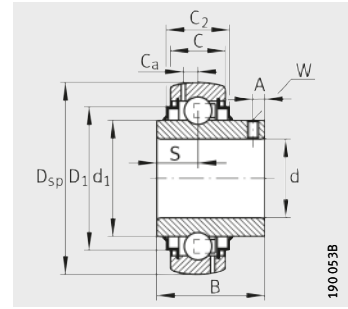

GY...KRR-B-AS2/V



					Width across flats W inch	Basic load ratings		Fatigue limit load Cur N	Factor <sup>2)</sup> f0	Shaft diameter d	
D1	Ca	B1	d3	A		dyn. Cr N	stat. Cor N			inch	mm
-	-	43,8	58	-	3/16	34 500	19 800	1 010	14	1 1/2	38,1
-	6,5	43,8	58	-	3/16	34 500	19 800	1 010	14		
68,3	6,5	56,5	58	-	3/16	34 500	19 800	1 010	14		
72,3	6,4	56,5	63	-	3/16	34 500	20 400	1 030	14,3	1 5/8	41,275
72,3	6,4	56,5	63	-	3/16	34 500	20 400	1 030	14,3	1 11/16	42,8625
72,3	6,4	56,5	63	-	3/16	34 500	20 400	1 030	14,3	1 3/4	44,45
71,7	6,4	-	-	8	5/32	34 500	20 400	1 030	14,3		
-	6,8	43,8	69	-	3/16	37 500	23 200	1 180	14,3	1 15/16	49,2125
77,3	6,8	62,75	69	-	3/16	37 500	23 200	1 180	14,3		
76,7	6,8	-	-	10	5/32	37 500	23 200	1 180	14,3		
85,9	7,1	71,4	76	-	3/16	46 000	29 000	1 480	14,3	2	50,8
85,3	7,1	-	-	9,1	5/32	46 000	29 000	1 480	14,3		
85,3	7,08	71,4	76	-	3/16	46 000	29 000	1 480	14,3	2 3/16	55,5625
85,3	7,1	-	-	10	5/32	46 000	29 000	1 480	14,3		
95,3	7,8	77,9	84	-	3/16	56 000	36 000	1 820	14,3	2 7/16	61,912
112,9	8,56	67	100,5	-	1/4	66 000	44 500	2 240	14,7	2 15/16	74,6125
113	8,5	-	-	12,6	3/16	66 000	44 500	2 240	14,7		



**Radial insert ball bearings  
with cylindrical outer ring**

# Radial insert ball bearings with cylindrical outer ring

	Page
<b>Product overview</b>	
Radial insert ball bearings with cylindrical outer ring .....	196
<b>Features</b>	
X-life .....	198
Radial insert ball bearings with eccentric locking collar and slots in outer ring .....	199
Inch size designs .....	199
Deep groove ball bearings with bore for fit .....	200
Deep groove ball bearings with profiled bore.....	201
Suffixes.....	201
<b>Dimension tables</b>	
Radial insert ball bearings with eccentric locking collar .....	202
Deep groove ball bearings with extended inner ring, bore for fit .....	206
Deep groove ball bearings with extended inner ring, hexagonal bore .....	208
Inch size radial insert ball bearings.....	210



# Product overview Radial insert ball bearings with cylindrical outer ring

## With eccentric locking collar

RAE...XL-NPP, RALE...XL-NPP



E...XL-KLL



E...XL-KRR



## One snap ring in outer ring

RAE...XL-NPP-NR



**Deep groove ball bearings  
with extended inner ring**

With bore for fit

2..-XL-KRR, 2..-XL-KRR-AH



With hexagonal bore

SK..-KRR



SK..-KTT



**Inch size  
radial insert ball bearings**

With eccentric locking collar

RA..-NPP, RAL..-NPP



# Radial insert ball bearings with cylindrical outer ring

## Features

Radial insert ball bearings with cylindrical outer ring are single row, ready-to-fit units comprising a solid outer ring, an inner ring extended on one or both sides, cages made from plastic and seals of type P or R. Bearings with an inner ring extended on both sides undergo less tilting of the inner ring and therefore run more smoothly.

The radial insert ball bearings are greased and cannot be relubricated.

Radial insert ball bearings are particularly easy to fit and are preferentially suitable for drawn shafts of tolerance classes h6  $\oplus$  to h9  $\oplus$ . They are located on the shaft by means of an eccentric locking collar or a location fit.



The series comparison matrix presents the features of the series in detail, see table, page 146.

## X-life

Numerous sizes are supplied in the X-life design. These products are indicated in the dimension tables.

Radial insert ball bearings of X-life quality have, for example, lower roughness Ra and higher geometrical accuracy of the raceways than comparable designs that are not X-life. As a result, these bearings have higher load carrying capacity and longer rating life although their dimensions are identical. In certain applications, this means that a smaller bearing arrangement can be designed.

Radial insert ball bearings of X-life quality have an eccentric locking collar of an improved design and the quantity and distribution of the lubricant has been optimised. Housings ASE have additional crosspieces on the underside. For extreme requirements, the cage and seal material in the high and low temperature designs (suffix FA101) has been significantly improved in comparison with earlier versions.



## Radial insert ball bearings with eccentric locking collar and slots in outer ring

The basic design of series RAE...XL-NPP-NR is a radial insert ball bearing with an eccentric locking collar and an inner ring extended on one side, *Figure 1*. The outer ring has a cylindrical outside surface and two slots to DIN 616 and ISO 464. The bearings are fitted in cylindrical bores and axially located by easy-to-fit snap rings. The bearing is supplied with one snap ring to DIN 5417 already fitted.



RAE...XL-NPP-NR

*Figure 1*  
Radial insert ball bearing with cylindrical outer ring and two slots in outer ring

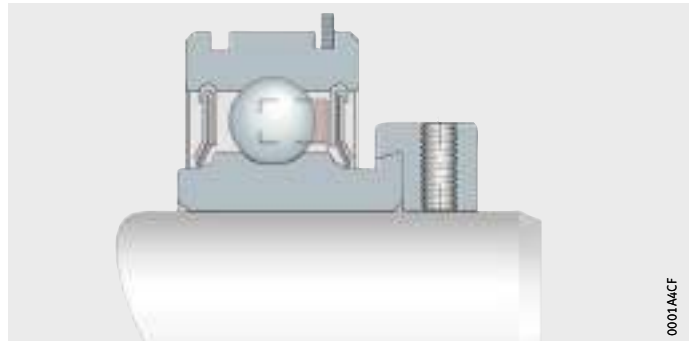

**Seals** The bearings are sealed on both sides using P type seals, see page 119.

**Lubrication** The radial insert ball bearings are greased and cannot be relubricated.

**Inch size designs** Some series with an eccentric locking collar are also available with inch size bore dimensions, see page 210.

## Radial insert ball bearings with cylindrical outer ring

### Deep groove ball bearings with bore for fit

These bearings have a cylindrical outer ring and are fitted in cylindrical bores, *Figure 2*. The inner ring is extended on both sides and is located on the shaft using a location fit. Due to the extended inner ring, additional axial spacer rings are not required.

The concentric seat allows speeds equivalent to those of standard ball bearings, while the load can be either constant or alternating. Smooth running is also achieved.

The tolerance of the inner ring bore corresponds to tolerance class Normal to ISO 492.

2...-XL-KRR  
2...-XL-KRR-AH

*Figure 2*  
Deep groove ball bearing with extended inner ring and bore for fit

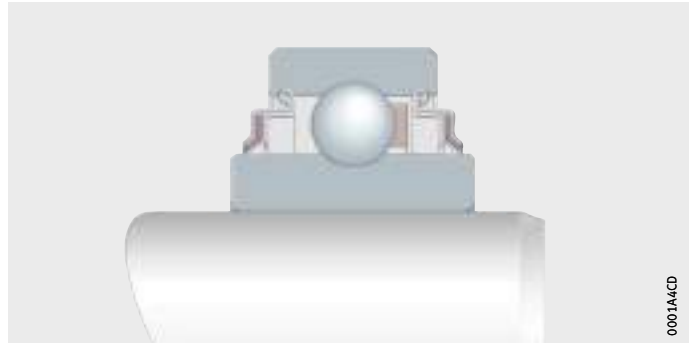

**Seals** The bearings are sealed on both sides using R type seals, see page 119.

**Lubrication** The sheet steel washers extended outwards and angled downwards form a large grease reservoir.

## Deep groove ball bearings with profiled bore

Bearings with a profiled bore are used where shafts must transmit very high torques and this is only possible using hexagonal shafts, *Figure 3*. Rotation is prevented by form fit.

These bearings have a cylindrical outer ring and an inner ring that is extended on both sides.

Shafts of tolerance class h11 © are recommended.



SK...KRR  
SK...KTT

① Hexagonal bore

*Figure 3*  
Deep groove ball bearings with extended inner ring and profiled bore

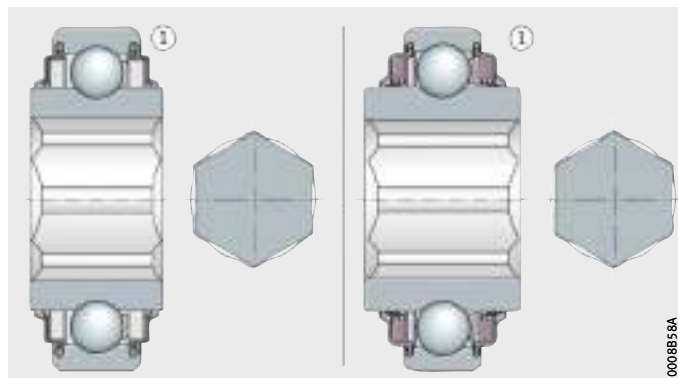

### Anti-corrosion protection

The bearings have a Corrotect coating.

### Seals

The self-aligning deep groove ball bearings are sealed using seals R or T, see page 119.

### Lubrication

The bearings contain the maximum quantity of grease.

### Suffixes

Suffixes for available designs, see table.

### Available designs

Suffix	Description	Design
FA106	Bearing subjected to special noise testing	Standard
KRR	Lip seals on both sides (R type seal)	
KLL	Labyrinth seals on both sides (L type seal)	
NR	Slot and snap ring for radial insert ball bearing with cylindrical outer ring	
NPP	Lip seals on both sides (P seal)	

# Radial insert ball bearings with eccentric locking collar

Cylindrical outer ring

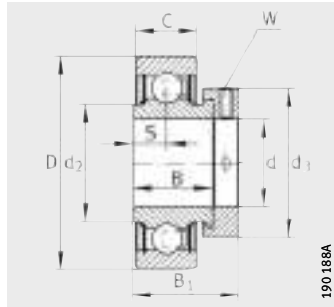

RAE...-XL-NPP-FA106,  
RALE...-XL-NPP

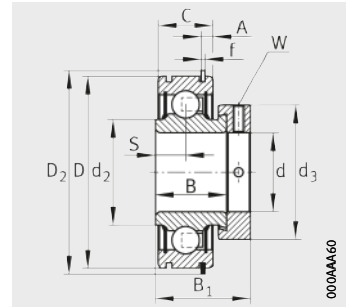

RAE...-XL-NPP-NR

**Dimension table** - Dimensions in mm

Designation <sup>1)</sup>	Mass m ≈ kg	Dimensions							
		d	D	D <sub>2</sub>	C	C <sub>2</sub>	A	f	B
RAE12-XL-NPP-FA106	0,13	12	40	–	12	–	–	–	19
RAE15-XL-NPP-FA106	0,12	15	40	–	12	–	–	–	19
RAE17-XL-NPP-FA106	0,11	17	40	–	12	–	–	–	19
RALE20-XL-NPP-FA106	0,1	20	42	–	12	–	–	–	16,7
RAE20-XL-NPP-FA106	0,17	20	47	–	14	–	–	–	21,4
RAE20-XL-NPP-NR	0,17	20	47	52,7	14	–	3,58 <sup>0</sup> <sub>-0,25</sub>	1,12 <sup>0</sup> <sub>-0,1</sub>	21,4
E20-XL-KLL	0,2	20	47	–	14	16,6	–	–	34,1
E20-XL-KRR	0,2	20	47	–	14	16,6	–	–	34,1
RALE25-XL-NPP	0,13	25	47	–	12	–	–	–	17,5
RAE25-XL-NPP-FA106	0,2	25	52	–	15	–	–	–	21,4
RAE25-XL-NPP-NR	0,2	25	52	57,9	15	–	3,58 <sup>0</sup> <sub>-0,25</sub>	1,12 <sup>0</sup> <sub>-0,1</sub>	21,4
E25-XL-KLL	0,25	25	52	–	15	20,2	–	–	34,9
E25-XL-KRR	0,25	25	52	–	15	16,7	–	–	34,9
RALE30-XL-NPP-FA106	0,18	30	55	–	13	–	–	–	18,5
RAE30-XL-NPP-FA106	0,33	30	62	–	18	–	–	–	23,8
RAE30-XL-NPP-NR	0,33	30	62	67,7	18	–	4,98 <sup>0</sup> <sub>-0,3</sub>	1,7 <sup>0</sup> <sub>-0,1</sub>	23,8
E30-XL-KLL	0,39	30	62	–	18	20,6	–	–	36,5
E30-XL-KRR	0,4	30	62	–	18	20,7	–	–	36,5
RAE35-XL-NPP-FA106	0,54	35	72	–	19	–	–	–	25,4
RAE35-XL-NPP-NR	0,53	35	72	78,6	19	–	4,98 <sup>0</sup> <sub>-0,3</sub>	1,7 <sup>0</sup> <sub>-0,1</sub>	25,4
E35-XL-KLL	0,6	35	72	–	19	25,4	–	–	37,7
E35-XL-KRR	0,61	35	72	–	19	21,7	–	–	37,7

<sup>1)</sup> Permissible speeds of radial insert ball bearings: see page 148.

<sup>2)</sup> Factor  $f_0$  for determining equivalent bearing load, see table, page 40.

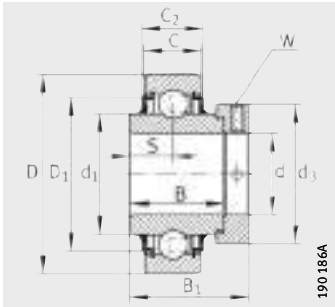

E..-XL-KLL

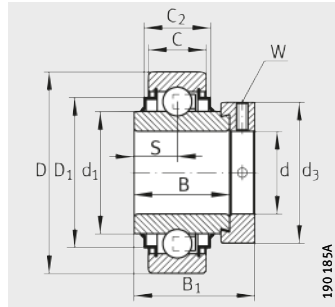

E..-XL-KRR



						Width across flats W	Basic load ratings		Fatigue limit load C <sub>ur</sub> N	Factor <sup>2)</sup> f <sub>0</sub>
S	d <sub>1</sub>	d <sub>2</sub>	D <sub>1</sub>	B <sub>1</sub>	d <sub>3</sub> max.		dyn. C <sub>r</sub> N	stat. C <sub>0r</sub> N		
6,5	-	23	-	28,6	28,4	3	10 100	4 750	241	13,1
6,5	-	23	-	28,6	28,4	3	10 100	4 750	241	13,1
6,5	-	23	-	28,6	28,4	3	10 100	4 750	241	13,1
6	-	25,4	-	24,5	30	2,5	10 000	5 000	255	13,9
7,5	-	26,9	-	31	33	3	13 600	6 600	335	13,1
7,5	-	26,9	-	31	33	3	13 600	6 600	335	13,1
17,1	27,6	-	37,4	43,7	33	3	13 600	6 600	335	13,1
17,1	27,6	-	37,4	43,7	33	3	13 600	6 600	335	13,1
6	-	30	-	25,5	36	2,5	10 700	5 900	295	14,5
7,5	-	30,5	-	31	37,5	3	14 900	7 800	395	13,8
7,5	-	30,5	-	31	37,5	3	14 900	7 800	395	13,8
17,5	33,8	-	42,5	44,5	37,5	3	14 900	7 800	395	13,8
17,5	33,8	-	42,5	44,5	37,5	3	14 900	7 800	395	13,8
6,5	-	35,7	-	26,5	42,5	2,5	14 100	8 300	420	14,8
9	-	37,4	-	35,8	44	4	20 700	11 300	570	13,8
9	-	37,4	-	35,8	44	4	20 700	11 300	570	13,8
18,3	40,2	-	52	48,5	44	4	20 700	11 300	570	13,8
18,3	40,2	-	52	48,5	44	4	20 700	11 300	570	13,8
9,5	-	44,6	-	39	55	5	27 500	15 300	770	13,8
9,5	-	44,6	-	39	55	5	27 500	15 300	770	13,8
18,8	46,8	-	60,3	51,3	55	5	27 500	15 300	770	13,8
18,8	46,8	-	60,3	51,3	55	5	27 500	15 300	770	13,8

# Radial insert ball bearings with eccentric locking collar

Cylindrical outer ring

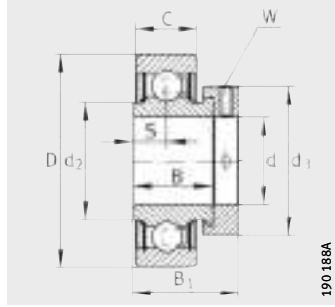

RAE...-XL-NPP(-FA106),  
RALE..-XL-NPP

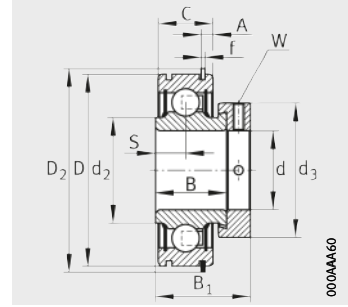

RAE...-XL-NPP-NR

**Dimension table** (continued) · Dimensions in mm

Designation <sup>1)</sup>	Mass m ≈ kg	Dimensions							
		d	D	D <sub>2</sub>	C	C <sub>2</sub>	A	f	B
<b>RAE40-XL-NPP-FA106</b>	0,64	<b>40</b>	80	–	21	–	–	–	30,2
<b>RAE40-XL-NPP-NR</b>	0,64	<b>40</b>	80	86,6	21	–	4,98 <sup>0</sup> <sub>-0,3</sub>	1,7 <sup>0</sup> <sub>-0,1</sub>	30,2
<b>E40-XL-KLL</b>	0,76	<b>40</b>	80	–	21	28,1	–	–	42,9
<b>E40-XL-KRR</b>	0,75	<b>40</b>	80	–	21	23,5	–	–	42,9
<b>RAE45-XL-NPP-FA106</b>	0,72	<b>45</b>	85	–	22	–	–	–	30,2
<b>E45-XL-KLL</b>	0,85	<b>45</b>	85	–	22	26,4	–	–	42,9
<b>E45-XL-KRR</b>	0,85	<b>45</b>	85	–	22	26,4	–	–	42,9
<b>RAE50-XL-NPP-FA106</b>	0,79	<b>50</b>	90	–	22	–	–	–	30,2
<b>E50-XL-KLL</b>	1	<b>50</b>	90	–	22	26,4	–	–	49,2
<b>E50-XL-KRR</b>	1	<b>50</b>	90	–	22	26,4	–	–	49,2
<b>RAE60-XL-NPP</b>	1,43	<b>60</b>	110	–	24	–	–	–	37,1
<b>E60-XL-KRR</b>	1,82	<b>60</b>	110	–	24	29	–	–	61,9
<b>E70-XL-KRR</b>	2,45	<b>70</b>	125	–	28	32	–	–	48,5

<sup>1)</sup> Permissible speeds of radial insert ball bearings: see page 148.

<sup>2)</sup> Factor  $f_0$  for determining equivalent bearing load, see table, page 40.

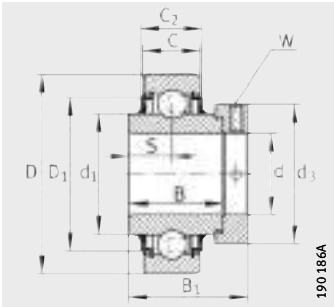

E..-XL-KLL

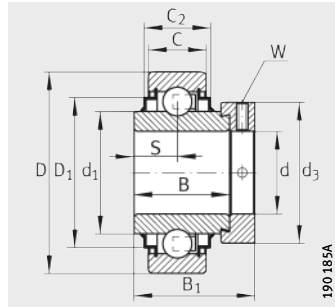

E..-XL-KRR



S	d <sub>1</sub>	d <sub>2</sub>	D <sub>1</sub>	B <sub>1</sub>	d <sub>3</sub> max.	Width across flats W	Basic load ratings		Fatigue limit load C <sub>ur</sub> N	Factor <sup>2)</sup> f <sub>0</sub>
							dyn. C <sub>r</sub> N	stat. C <sub>0r</sub> N		
11	–	49,4	–	43,8	58	5	34 500	19 800	1 010	14
11	–	49,4	–	43,8	58	5	34 500	19 800	1 010	14
21,4	52,3	–	68,3	56,5	58	5	34 500	19 800	1 010	14
21,4	52,3	–	68,3	56,5	58	5	34 500	19 800	1 010	14
11	–	54,5	–	43,8	63	5	34 500	20 400	1 030	14,3
21,4	57,9	–	72,3	56,5	63	5	34 500	20 400	1 030	14,3
21,4	57,9	–	72,3	56,5	63	5	34 500	20 400	1 030	14,3
11	–	59,4	–	43,8	69	5	37 500	23 200	1 180	14,3
24,6	62,8	–	77,3	62,8	69	5	37 500	23 200	1 180	14,3
24,6	62,8	–	77,3	62,8	69	5	37 500	23 200	1 180	14,3
13,5	–	72	–	53,1	84	5	56 000	36 000	1 820	14,3
31	76,5	–	94,5	77,9	84	5	56 000	36 000	1 820	14,3
21,5	85,2	–	109	66	96	6	66 000	44 000	2 230	14,4

# Deep groove ball bearings with extended inner ring

Cylindrical outer ring  
Bore for fit

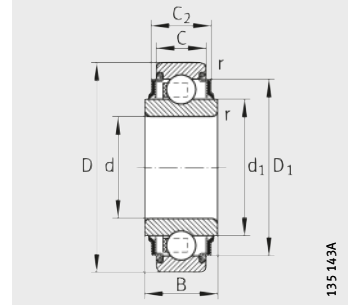

2..-XL-KRR, 2..-XL-KRR-AH..



**Dimension table** - Dimensions in mm

Designation <sup>1)</sup>	Mass m ≈ kg	Dimensions								
		d	D	C	C <sub>2</sub>	d <sub>1</sub>	D <sub>1</sub>	B	r <sub>min</sub>	
203-XL-KRR-AH05 <sup>3)</sup>	0,09	<b>13</b> $\begin{smallmatrix} +0,08 \\ -0,05 \end{smallmatrix}$	40	12	12	24,2	40	18,3	0,6	
202-XL-KRR	0,05	<b>15</b>	35	11	11	21,5	28,8	14,4	0,6	
203-XL-KRR-AH02	0,07	<b>16,2</b> $\begin{smallmatrix} +0,1 \\ 0 \end{smallmatrix}$	40	12	12	24,2	32,6	18,3	0,6	
203-XL-KRR	0,07	<b>17</b>	40	12	12	24,2	32,9	18,3	0,6	
204-XL-KRR	0,12	<b>20</b>	47	14	14	28,7	38,7	17,7	1	
205-XL-KRR	0,16	<b>25</b>	52	15	16,7	33,8	42,6	21	1	
206-XL-KRR	0,24	<b>30</b>	62	16	19,6	40,2	52	24	1	
207-XL-KRR-AH03 <sup>4)</sup>	0,35	<b>35</b>	72	17	19,7	46,8	60,3	25	2	
208-XL-KRR-AH04 <sup>4)</sup>	0,48	<b>38,892</b>	80	21	21,2	52,3	68,2	27,5	1	
208-XL-KRR	0,44	<b>40</b>	80	18	20,5	52,3	68,2	27	1,1	
209-XL-KRR	0,53	<b>45</b>	85	19	26,4	57,9	72,3	30	1,1	
210-XL-KRR	0,58	<b>50</b>	90	20	24	62,8	77,6	30	1,1	
211-XL-KRR	0,85	<b>55</b>	100	21	27,5	69,8	85,9	36	1,5	
212-XL-KRR	1,1	<b>60</b>	110	22	30	76,5	94,7	36	1,5	

1) Internal clearance Group N.

2) Factor  $f_0$  for determining equivalent bearing load, see table, page 40.

3) Greased with L114 (GA47).

4) With steel cage.





Limiting speed $n_G$ grease $\text{min}^{-1}$	Basic load ratings		Fatigue limit load $C_{ur}$ N	Factor <sup>2)</sup> $f_0$
	dyn. $C_r$ N	stat. $C_{0r}$ N		
11 100	10 100	4 750	241	13,1
12 700	8 100	3 700	187	13,1
11 100	10 100	4 750	241	13,1
11 100	10 100	4 750	241	13,1
9 300	13 600	6 600	335	13,1
8 000	14 900	7 800	395	13,8
6 700	20 700	11 300	570	13,8
5 700	27 500	15 300	770	13,8
5 000	34 500	19 800	1 010	14
5 000	34 500	19 800	1 010	14
4 650	34 500	20 400	1 030	14,3
4 300	37 500	23 200	1 180	14,3
3 900	46 000	29 000	1 480	14,3
3 550	56 000	36 000	1 820	14,3

# Deep groove ball bearings with extended inner ring

Cylindrical outer ring  
Hexagonal bore

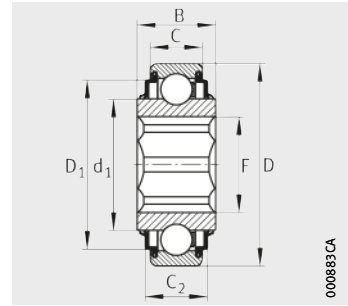

SK...KRR(-L402/70)(-AH)

**Dimension table** - Dimensions in mm

Width across flats of shaft d		Designation	Mass m ≈ kg	Dimensions			
				d	D	C	C <sub>2</sub>
inch	mm						
7/8	22,225	SK014-205-KRR	0,18	22,225 <sup>+0,15</sup> <sub>+0,05</sub>	52	15	16,5
1	25,4	SK100-206-KRR-AH11	0,27	25,4 <sup>+0,15</sup> <sub>+0,05</sub>	62	16	19
1 1/4	31,75	SK104-207-KRR-L402/70-AH12	0,35	31,75 <sup>+0,15</sup> <sub>+0,05</sub>	72	17	18,7
		SK104-208-KTT-L402/70-AH10	0,62	31,75 <sup>+0,15</sup> <sub>+0,05</sub>	80	18	25
1 3/4	44,45	SK112-312-KTT-L402/70	2,62	44,45 <sup>+0,127</sup> <sub>0</sub>	130	33	41,3

<sup>1)</sup> Factor f<sub>0</sub> for determining equivalent bearing load, see table, page 40.

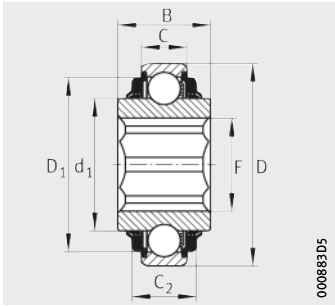

SK..-KTT-L402/70(-AH)

000883D5

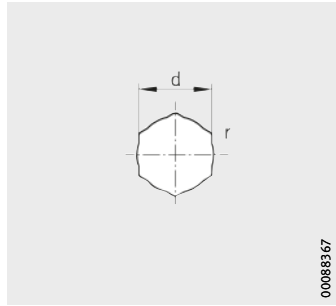

Design of bore

000883E7



					Basic load ratings		Fatigue limit load $C_{ur}$ N	Factor <sup>1)</sup> $f_0$	Width across flats of shaft d	
$d_1$	F	$D_1$	B	r	dyn. $C_r$ N	stat. $C_{0r}$ N			inch	mm
33,8	26,5	42,5	25,4	0,12	14 900	7 800	395	13,8	$7/8$	<b>22,225</b>
40,2	30	52	24	0,12	20 700	11 300	570	13,8	<b>1</b>	<b>25,4</b>
46,8	38	60	25	0,12	27 500	15 300	770	13,8	$1\frac{1}{4}$	<b>31,75</b>
52,3	38	68,4	36,5	0,12	34 500	19 800	1 010	14		
79,4	51,6	108,9	48	0,13	87 000	52 000	2 650	13,1	$1\frac{3}{4}$	<b>44,45</b>

# Inch size radial insert ball bearings

Cylindrical outer ring

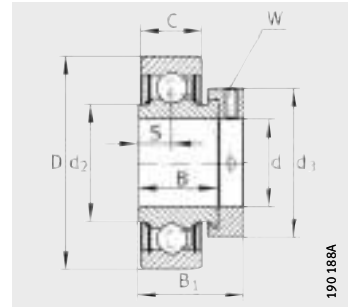

RA..-NPP, RAL..-NPP

**Dimension table** - Dimensions in mm

Shaft diameter		Designation <sup>1)</sup>	Mass	Dimensions				
				D	C	B	B <sub>1</sub>	S
d			m					
inch	mm		≈ kg					
3/4	<b>19,05</b>	<b>RAL012-NPP</b>	0,09	42	12	16,7	24,6	6
7/8	<b>22,225</b>	<b>RA014-NPP</b>	0,19	52	15	21,4	31	7,5
<b>1</b>	<b>25,4</b>	<b>RA100-NPP</b>	0,19	52	15	21,4	31	7,5
1 <sup>1</sup> / <sub>8</sub>	<b>28,575</b>	<b>RA102-NPP</b>	0,31	62	18	23,8	35,8	9
1 <sup>3</sup> / <sub>16</sub>	<b>30,1625</b>	<b>RA103-NPP</b>	0,31	62	18	23,8	35,8	9
1 <sup>1</sup> / <sub>4</sub>	<b>31,75</b>	<b>RA104-206-NPP</b>	0,31	62	18	23,8	35,8	9
		<b>RA104-NPP</b>	0,48	72	19	25,4	39	9,5
1 <sup>7</sup> / <sub>16</sub>	<b>36,5125</b>	<b>RA107-NPP</b>	0,48	72	19	25,4	39	9,5
1 <sup>1</sup> / <sub>2</sub>	<b>38,1</b>	<b>RA108-NPP</b>	0,62	80	21	30,2	43,8	11

1) Permissible speeds of radial insert ball bearings: see page 148.

2) Factor  $f_0$  for determining equivalent bearing load, see table, page 40.



		Width across flats W inch	Basic load ratings		Fatigue limit load C <sub>ur</sub> N	Factor <sup>2)</sup> f <sub>0</sub>	Shaft diameter d	
d <sub>2</sub>	d <sub>3</sub> max.		dyn. C <sub>r</sub> N	stat. C <sub>0r</sub> N			inch	mm
25,4	30	1/8	10 000	5 000	255	13,9	3/4	<b>19,05</b>
30,5	37,5	1/8	14 900	7 800	395	13,8	7/8	<b>22,225</b>
30,5	37,5	1/8	14 900	7 800	395	13,8	<b>1</b>	<b>25,4</b>
37,4	44	5/32	20 700	11 300	570	13,8	1 1/8	<b>28,575</b>
37,4	44	5/32	20 700	11 300	570	13,8	1 3/16	<b>30,1625</b>
37,4	44	5/32	20 700	11 300	570	13,8	1 1/4	<b>31,75</b>
44,6	51	3/16	27 500	15 300	770	13,8		
44,6	51	3/16	27 500	15 300	770	13,8	1 7/16	<b>36,5125</b>
49,4	58	3/16	34 500	19 800	1 010	14	1 1/2	<b>38,1</b>



**Radial insert ball bearings  
with rubber interliner or  
steel aligning ring**

# Radial insert ball bearings with rubber interliner or steel aligning ring

	Page
<b>Product overview</b>	
Radial insert ball bearings with rubber interliner or steel aligning ring .....	214
<b>Features</b>	
X-life .....	215
Radial insert ball bearings with rubber interliner .....	216
Radial insert ball bearings with steel aligning ring .....	217
Suffixes .....	217
<b>Dimension tables</b>	
Radial insert ball bearings with rubber interliner, spherical or cylindrical outside surface of interliner.....	218
Radial insert ball bearings with steel aligning ring.....	220



## Product overview

# Radial insert ball bearings with rubber interliner or steel aligning ring

**With rubber interliner**  
With spherical or cylindrical  
outside surface

RABRA..-XL-FA106,  
RABRB..-XL-FA106



RCRA..-XL-FA106,  
RCRB..-XL-FA106



CRB..-XL



RCSMA..-XL-FA106,  
RCSMB..-XL-FA106



**With steel aligning ring**

PE..-XL



BE..-XL





## Radial insert ball bearings with rubber interliner or steel aligning ring

**Features** Radial insert ball bearings are particularly easy to fit and are preferentially suitable for drawn shafts of tolerance classes h6  $\oplus$  to h9  $\oplus$ . For non-locating bearings, shafts of tolerance class h7  $\oplus$  are recommended. They are located on the shaft by means of an eccentric locking collar.

**X-life** Numerous sizes are supplied in the X-life design. These products are indicated in the dimension tables.

Radial insert ball bearings of X-life quality have, for example, lower roughness Ra and higher geometrical accuracy of the raceways than comparable designs that are not X-life. As a result, these bearings have higher load carrying capacity and longer rating life although their dimensions are identical. In certain applications, this means that a smaller bearing arrangement can be designed.

Radial insert ball bearings of X-life quality have an eccentric locking collar of an improved design and the quantity and distribution of the lubricant has been optimised. Housings ASE have additional crosspieces on the underside. For extreme requirements, the cage and seal material in the high and low temperature designs (suffix FA101) has been significantly improved in comparison with earlier versions.



# Radial insert ball bearings with rubber interliner or steel aligning ring

## Radial insert ball bearings with rubber interliner

Radial insert ball bearings with a rubber interliner are located on the shaft using an eccentric locking collar. The outer ring is encased in a thick-walled NBR interliner, *Figure 1*.

The interliner absorbs vibrations and shocks and thus gives damping of running noises.

The interliners have a spherical or cylindrical outside surface.

For roll bearing arrangements, one series has a locating shoulder on the rubber ring.

**CRB..-XL**

① Locating shoulder

*Figure 1*  
Radial insert ball bearing  
with rubber interliner

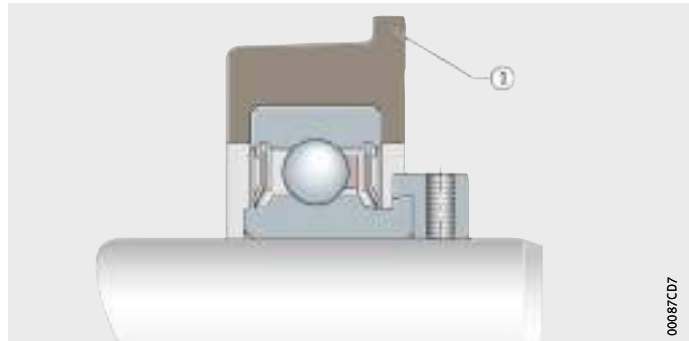

### Anti-corrosion protection

The inner ring and locking collar have a Corrotect coating and are thus protected against fretting corrosion. This is not valid for series with the radial insert ball bearing RALE..-XL-NPP(-B).

### Seals

The bearings are sealed on both sides using P type seals, see page 119.

### Lubrication



Bearings with rubber interliners cannot be lubricated.  
Note the tube and housing diameters for radial insert ball bearings with rubber interliner:

- CRB: tube inside diameter D –0,6 to –1,6
- RABR, RCR, RCSM: housing diameter D –0,25 to –0,35.

## Radial insert ball bearings with steel aligning ring

These bearings are based on radial insert ball bearings with an eccentric locking collar or on self-aligning deep groove ball bearings, but additionally have an axially split outer ring as an aligning ring, *Figure 2*. They are mounted in cylindrical bores and can compensate for static misalignment of the shaft up to  $\pm 5^\circ$ .

Due to the annular slots in the outer ring to DIN 616, they are highly suitable for sheet metal constructions. In this case, they are axially located using snap rings to DIN 5417.

The inner ring is located on the shaft by means of a locking collar in the case of series PE and by a location fit in the case of series BE.



PE...XL

*Figure 2*

Radial insert ball bearing with steel aligning ring

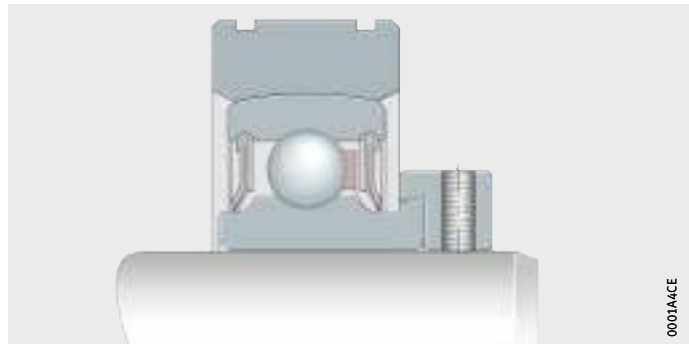

### Anti-corrosion protection

The aligning ring has a Corrotect coating and is thus protected against fretting corrosion. In the case of series PE...XL, the inner ring and locking collar also have a coating.

### Seals

The bearings are sealed on both sides using P type seals, see page 119.

### Lubrication

Radial insert ball bearings with an aligning ring cannot be relubricated.



The fit tolerances of the aligning rings are those of the deep groove ball bearings. Select the fit for the shaft and housing such that the outer ring of the radial insert ball bearing can undergo self-alignment.

### Suffix

Suffixes for available designs, see table.

### Available designs

Suffix	Description	Design
FA106	Bearing subjected to special noise testing	Standard

# Radial insert ball bearings with rubber interliner

Spherical or cylindrical outside surface of the interliner

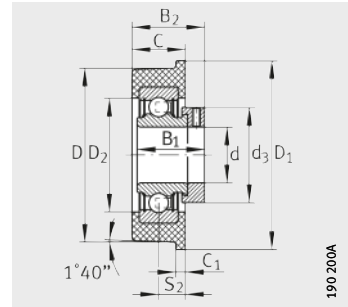

CRB..-XL



Dimension table - Dimensions in mm

Designation		Mass	Dimensions						
Unit <sup>1)</sup>	Radial insert ball bearing <sup>2)</sup>		d	D	D <sub>1</sub>	C	C <sub>2</sub>	C <sub>1</sub>	S <sub>1</sub>
		m							
		≈ kg							
<b>RABRB12/47-XL-FA106</b>	RAE12-XL-NPP-B-FA106	0,15	<b>12</b>	47,3	–	17,6	–	–	22,1
<b>RABRB15/47-XL-FA106</b>	RAE15-XL-NPP-B-FA106	0,15	<b>15</b>	47,3	–	18	–	–	22,1
<b>RCSMB15/65-XL-FA106</b>	RAE15-XL-NPP-FA106	0,18	<b>15</b>	65,1	–	25,4	–	–	22,1
<b>RCSMB17/65-XL-FA106</b>	RAE17-XL-NPP-FA106	0,18	<b>17</b>	65,1	–	25,4	–	–	22,1
<b>RCRA20/46-XL-FA106</b>	RAE20-XL-NPP-FA106	0,14	<b>20</b>	46	–	18,3	16	–	18,6
<b>RABRB20/52-XL-FA106</b>	RAE20-XL-NPP-B-FA106	0,2	<b>20</b>	52,3	–	17,6	–	–	23,5
<b>RCSMB20/65-XL-FA106</b>	RAE20-XL-NPP-FA106	0,22	<b>20</b>	65,1	–	25,4	–	–	23,5
<b>CRB20/76-XL</b>	RAE20-XL-NPP	0,3	<b>20</b>	77,5	80	25,4	–	5	–
<b>CRB20/83-XL</b>	RAE20-XL-NPP	0,3	<b>20</b>	83,6	87,4	25,4	–	4,8	–
<b>RCRB25/57-XL-FA106</b>	RAE25-XL-NPP-FA106	0,21	<b>25</b>	57,3	–	19,8	17,5	–	23,5
<b>RABRB25/62-XL-FA106</b>	RAE25-XL-NPP-B-FA106	0,24	<b>25</b>	62,2	–	20,8	–	–	23,5
<b>RCSMB25/65-XL-FA106</b>	RAE25-XL-NPP-FA106	0,24	<b>25</b>	65,1	–	25,4	–	–	23,5
<b>CRB25/70-XL</b>	RAE25-XL-NPP	0,32	<b>25</b>	71,5	76	25	–	5	–
<b>CRB25/72-XL</b>	RAE25-XL-NPP	0,32	<b>25</b>	73	80	25	–	5	–
<b>CRB25/83-XL</b>	RAE25-XL-NPP	0,32	<b>25</b>	83,6	87,4	25,4	–	4,8	–
<b>RABRA30/62-XL-FA106</b>	RAE30-XL-NPP-B-FA106	0,3	<b>30</b>	62,2	–	20,8	–	–	20
<b>RCSMA30/65-XL-FA106</b>	RAE30-XL-NPP-FA106	0,32	<b>30</b>	65,1	–	25,4	–	–	20
<b>RABRB30/72-XL-FA106</b>	RAE30-XL-NPP-B-FA106	0,38	<b>30</b>	72,2	–	23	–	–	26,7
<b>CRB30/83-XL</b>	RAE30-XL-NPP	0,41	<b>30</b>	83,6	87,4	28	–	4,8	–
<b>CRB30/92-XL</b>	RAE30-XL-NPP	0,41	<b>30</b>	93	98	28	–	5	–
<b>RABRB35/80-XL-FA106</b>	RAE35-XL-NPP-B-FA106	0,62	<b>35</b>	80,2	–	24	–	–	29,4
<b>CRB35/110-XL</b>	RAE35-XL-NPP	0,61	<b>35</b>	112,3	120	30	–	5	–
<b>RABRB40/85-XL-FA106</b>	RAE40-XL-NPP-B-FA106	0,73	<b>40</b>	85	–	27	–	–	32,7
<b>RABRB50/100-XL-FA106</b>	RAE50-XL-NPP-B-FA106	0,92	<b>50</b>	100,2	–	30	–	–	32,7

- 1) Operating temperature from –20 °C to +85 °C.
- 2) Permissible speeds of radial insert ball bearings: see page 148.
- 3) Factor  $f_0$  for determining equivalent bearing load, see table, page 40.
- 4) Also available by agreement in NBR80.

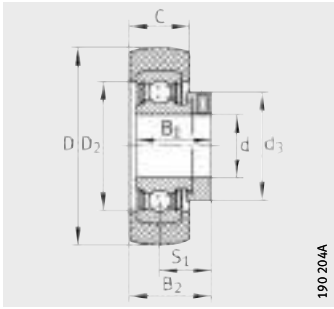

RABRA...XL-FA106,  
RABRB...XL-FA106

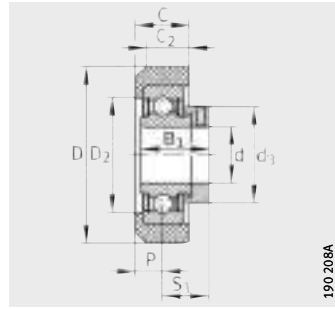

RARA...XL-FA106,  
RARB...XL-FA106

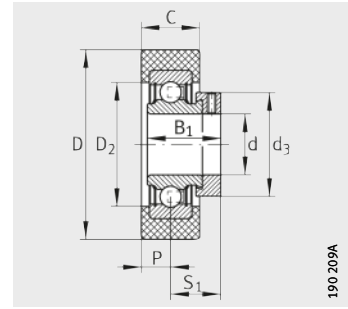

RCSMA...XL-FA106,  
RCSMB...XL-FA106



						Rubber ring		Basic load ratings		Fatigue limit load	Factor <sup>3)</sup>
D <sub>2</sub>	B <sub>1</sub>	P	d <sub>3</sub> max.	S <sub>2</sub>	B <sub>2</sub>	Hard- ness	Load carrying capacity	dyn. C <sub>r</sub> N	stat. C <sub>0r</sub> N	C <sub>ur</sub> N	f <sub>0</sub>
						Shore A °	C <sub>G</sub> N				
33,5	28,6	–	28,4	–	30,9	70	840	10 100	4 750	241	13,1
33,5	28,6	–	28,4	–	31,1	70	840	10 100	4 750	241	13,1
35	28,6	12,7	28,4	–	–	70	900	10 100	4 750	241	13,1
35	28,6	12,7	28,4	–	–	70	900	10 100	4 750	241	13,1
35	24,5	10	30	–	–	70	900	10 000	5 000	255	13,9
39	31	–	33	–	32,3	70	1 160	13 600	6 600	335	13,1
40	31	12,7	33	–	–	70	1 200	13 600	6 600	335	13,1
40	31	–	33	12,5	36	80	750	13 600	6 600	335	13,1
40	31	–	33	12,7	36,2	80	750	13 600	6 600	335	13,1
44,5	31	9,8	37,5	–	–	70	1 400	14 900	7 800	395	13,8
44,5	31	–	37,5	–	33,9	70 <sup>4)</sup>	1 390	14 900	7 800	395	13,8
46	31	12,7	37,5	–	–	70	1 400	14 900	7 800	395	13,8
46	31	–	37,5	12,5	36	80	1 000	14 900	7 800	395	13,8
46	31	–	37,5	12,5	36	80	1 000	14 900	7 800	395	13,8
46	31	–	37,5	12,7	36,2	80	1 000	14 900	7 800	395	13,8
47	26,5	–	42,5	–	30,4	70	1 390	14 100	8 300	420	14,8
47,6	26,5	15	42,5	–	–	70	1 400	14 100	8 300	420	14,8
54	35,8	–	44	–	38,2	70 <sup>4)</sup>	1 980	20 700	11 300	570	13,8
56	35,8	–	44	14	40,7	80	1 400	20 700	11 300	570	13,8
56	35,8	–	44	14	40,7	80	1 400	20 700	11 300	570	13,8
62	39	–	55	–	41,4	70	2 700	27 500	15 300	770	13,8
64	39	–	55	15	44,4	80	1 500	27 500	15 300	770	13,8
70	43,8	–	58	–	46,3	70 <sup>4)</sup>	3 500	34 500	19 800	1 010	14
80	43,8	–	69	–	47,7	70 <sup>4)</sup>	4 100	37 500	23 200	1 180	14,3

# Radial insert ball bearings with steel aligning ring

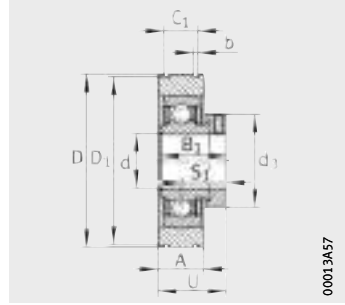

PE..-XL



**Dimension table** - Dimensions in mm

Designation		Mass m ≈ kg	Dimensions				
Unit <sup>2)</sup>	Radial insert ball bearing		d	D <sup>3)</sup>	A	C <sub>1</sub> <sup>4)</sup> +0,2	b <sup>4)</sup> +0,3
<b>PE20-XL</b>	<b>RAE20-XL-NPP-B</b>	0,24	<b>20</b>	55	16	11,2	1,35
<b>PE25-XL</b>	<b>RAE25-XL-NPP-B</b>	0,31	<b>25</b>	62	17	11,2	1,9
<b>PE30-XL</b>	<b>RAE30-XL-NPP-B</b>	0,48	<b>30</b>	72	21	14,4	1,9
<b>PE35-XL</b>	<b>RAE35-XL-NPP-B</b>	0,69	<b>35</b>	80	21	14,4	1,9
<b>PE40-XL</b>	<b>RAE40-XL-NPP-B</b>	0,88	<b>40</b>	90	25	15,4	2,7

**Dimension table** - Dimensions in mm

Designation		Mass m ≈ kg	Dimensions				
Unit <sup>5)</sup>	Radial insert ball bearing		d	D <sup>3)</sup>	A	C <sub>1</sub> <sup>4)</sup> +0,2	b <sup>4)</sup> +0,3
<b>BE20-XL</b>	<b>204-XL-NPP-B</b>	0,19	<b>20</b>	55	16	11,2	1,35
<b>BE25-XL</b>	<b>205-XL-NPP-B</b>	0,25	<b>25</b>	62	17	11,2	1,9
<b>BE30-XL</b>	<b>206-XL-NPP-B</b>	0,37	<b>30</b>	72	21	14,4	1,9
<b>BE35-XL</b>	<b>207-XL-NPP-B</b>	0,45	<b>35</b>	80	21	14,4	1,9
<b>BE40-XL</b>	<b>208-XL-NPP-B</b>	0,63	<b>40</b>	90	25	15,4	2,7

1) Factor  $f_0$  for determining equivalent bearing load, see table, page 40.

2) Permissible speeds of radial insert ball bearings RAE..NPP-B: see page 148.

3) Before splitting, dimension D corresponds to tolerance class Normal in accordance with ISO 492.

4) Annular slot tolerances to DIN 616 (for snap rings to DIN 5417).

5) Permissible speeds of self-aligning deep groove ball bearings 2..NPP-B: see page 182.

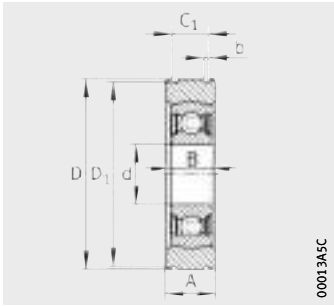

BE..-XL



					Basic load ratings		Fatigue limit load $C_{ur}$ N	Factor <sup>1)</sup> $f_0$
$D_1^{4)}$ -0,5	$B_1$	$S_1$	$d_3$ max.	U	dyn. $C_r$ N	stat. $C_{0r}$ N		
52,6	31	23,5	33	31,5	13 600	6 600	335	13,1
59,6	31	23,5	37,5	32	14 900	7 800	395	13,8
68,8	35,8	26,8	44	37,2	20 700	11 300	570	13,8
76,8	39	29,5	55	40	27 500	15 300	770	13,8
86,8	43,8	32,8	58	45,2	34 500	19 800	1 010	14

			Basic load ratings		Fatigue limit load $C_{ur}$ N	Factor <sup>1)</sup> $f_0$
$D_1^{4)}$ -0,5	B	U	dyn. $C_r$ N	stat. $C_{0r}$ N		
52,6	14	-	13 600	6 600	335	13,1
59,6	15	-	14 900	7 800	395	13,8
68,8	16	-	20 700	11 300	570	13,8
76,8	17	-	27 500	15 300	770	13,8
86,8	18	-	34 500	19 800	1 010	14







## Housing units

Flake graphite cast iron housings  
Sheet steel housings

# Units with flake graphite cast iron or sheet steel housing

## Plummer block housing units ..... 226

The single-piece flake graphite cast iron housings have a long or short base and a high load carrying capacity. They can compensate for static misalignment of the shaft.

---

## ..... 306

The two-piece sheet steel housings are made from steel strip of deep drawn quality. They are suitable for moderate loads and can compensate for static misalignment of the shaft.

## Two-bolt flanged housing units ..... 226

The single-piece, oval flake graphite cast iron housings are available in a narrow or wide version with or without a centring spigot.

---

## ..... 306

The predominantly two-piece, oval sheet steel housings are suitable for lightweight constructions with moderate loads. The units cannot be relubricated.

## Three-bolt flanged housing units ..... 226

The single-piece, triangular flake graphite cast iron housings have a high load carrying capacity. The units have three through holes.

---

## ..... 306

The two-piece sheet steel housings are suitable for lightweight constructions with moderate loads. The flanged housing units GRA and GRRY can be relubricated.

## Four-bolt flanged housing units ..... 226

The single-piece flake graphite cast iron housings are available in a square or round version with or without a centring spigot. The units have four through holes.

---

## ..... 306

The two-piece, round sheet steel housings are suitable for lightweight constructions with moderate loads. The flanged housing units GRA can be relubricated.

## Take-up housing units ..... 226

The single-piece flake graphite cast iron housings have guide slots on both sides, guide surfaces on both sides or additionally a sheet steel guide tube. They are used where shafts must undergo substantial displacement travel.

---

## ..... 306

The two-piece sheet steel housings are suitable for lightweight constructions with moderate loads. The units cannot be relubricated.

0008E47B

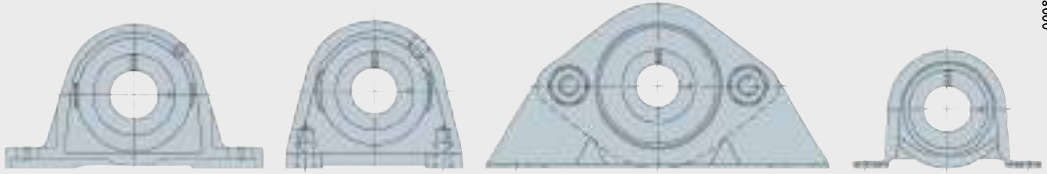

ASE  
SAO

SHE

GEH...PBS

GEH...BT

0008E483

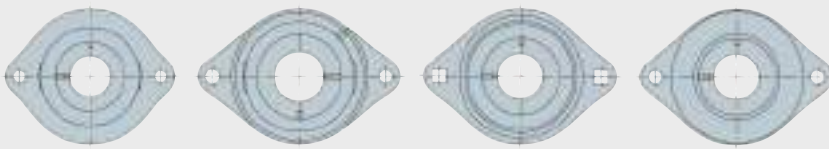

LCTE  
GLCTE

CJT  
CFT  
CJTZ

FLAN...MST  
FLAN...LST  
FLAN...CS(LT)

FLAN...RCSMF  
GRG...RCSM

0008E488

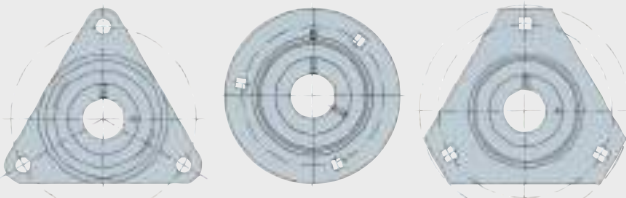

CFTR

FLAN...MSA  
FLAN...MSB

FLAN...LSTR  
FLAN...MSTR

0008E48C

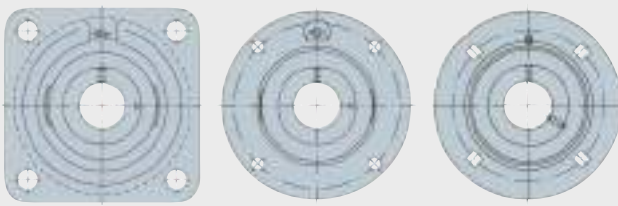

CJ  
CJO  
CF

ME  
MEO  
FE

FLAN...MSA  
FLAN...MSB

0008E490

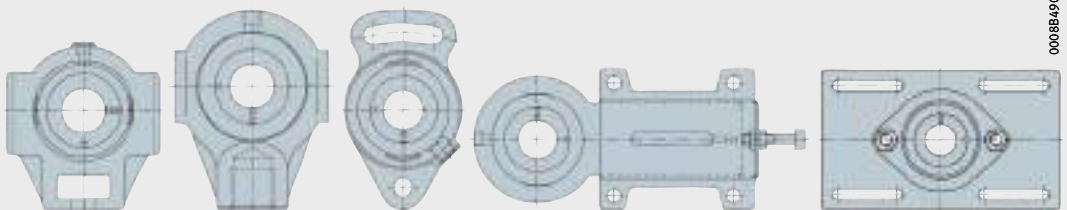

TUE  
TUEO

HE

SFT

HUE  
GEH...HUSE

GEH...MSTU



## Housing units with flake graphite cast iron housing

Plummer block housing units

Flanged housing units

Take-up housing units

# Housing units with flake graphite cast iron housing

	Page
<b>Product overview</b>	Housing units with flake graphite cast iron housing..... 229
<b>Matrix</b>	Possible combinations of radial insert ball bearings with cast iron housings..... 234
<b>Features</b>	X-life ..... 236 Plummer block housing units..... 236 Flanged housing units ..... 237 Take-up housing units ..... 237 Housing materials ..... 237 Bearing end caps..... 237 Operating temperature ..... 238 Lubrication ..... 238 Corrosion-resistant units ..... 239 Units for high and low temperatures..... 239 Market sectors..... 239 Suffixes..... 239
<b>Design and safety guidelines</b>	Compensation of static misalignments..... 240 Speed limits for radial insert ball bearings ..... 240 Load carrying capacity of housings ..... 241 Design of adjacent construction..... 241 Bearing end caps..... 242
<b>Accuracy</b>	Dimensional tolerances ..... 243
<b>Dimension tables</b>	Plummer block housing units, with long base, eccentric locking collar..... 244 Plummer block housing units, with long base, grub screws in inner ring..... 250 Plummer block housing units, with long base, adapter sleeve or drive slot..... 252 Plummer block housing units, with short base ..... 254



## Housing units with flake graphite cast iron housing

	Page
Two-bolt flanged housing units, oval wide version .....	258
Two-bolt flanged housing units, oval narrow version, eccentric locking collar .....	262
Two-bolt flanged housing units, oval narrow version, grub screws in inner ring or adapter sleeve .....	266
Two-bolt flanged housing units, oval narrow version, with centring spigot .....	270
Three-bolt flanged housing units .....	272
Four-bolt flanged housing units, square version, eccentric locking collar .....	274
Four-bolt flanged housing units, square version, grub screws in inner ring or drive slot .....	280
Four-bolt flanged housing units, round version, with wide centring spigot .....	284
Four-bolt flanged housing units, round version, with narrow centring spigot .....	290
Four-bolt flanged housing units, with double row angular contact ball bearing .....	292
Take-up housing units, guide slots on both sides, hole for threaded rod .....	294
Take-up housing units, guide surfaces on both sides, with threaded hole .....	300
Take-up housing units, guide tube, with adjusting screw .....	302
Take-up housing units, self-aligning .....	304

# Product overview **Housing units with flake graphite cast iron housing**

## **Plummer block housing units** With long base

PASE..-XL, PASEY..-XL, RASE..-XL, RASEL..-XL, RASEA..-XL,  
RASEY..-XL, TASE..-XL, LASE..-XL, RSAO..-XL

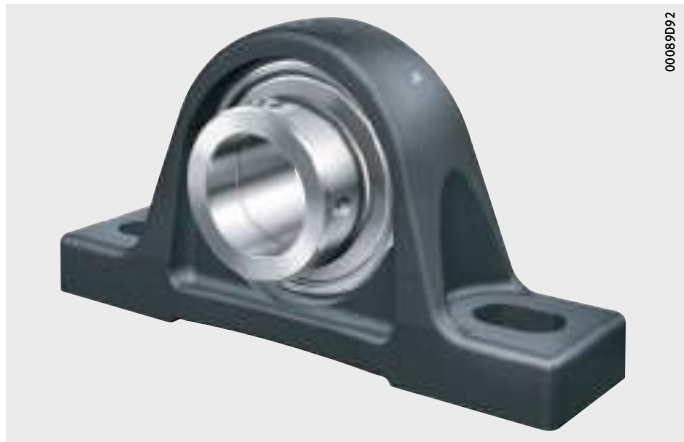

## With short base

PSHE..-XL, PSHEY..-XL, RSHE..-XL, RSHEY..-XL, TSHE..-XL

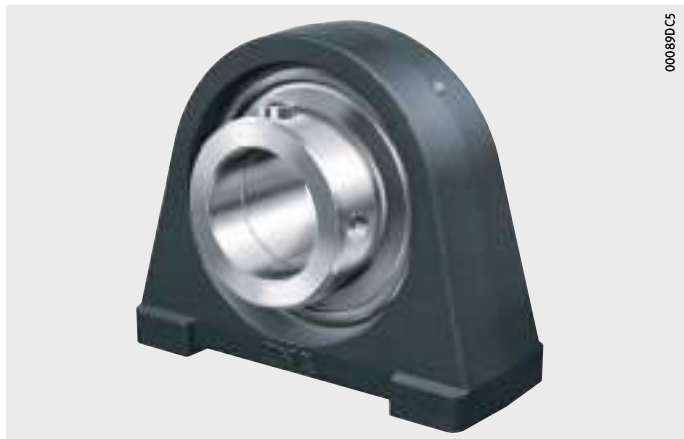

## Product overview

## Housing units with flake graphite cast iron housing

### Two-bolt flanged housing units

PCJT..-XL, PCJTY..-XL, RCJTZ..-XL, RCJT..-XL, RCJTA..-XL, RCJTY..-XL,  
PCFT..-XL, TCJT..-XL, LCJT..-XL



FLCTE..-XL, FLCTEY..-XL, GLCTE..-XL



### Three-bolt flanged housing units

PCFTR..-XL





**Four-bolt  
flanged housing units**

PCJ..-XL, PCJY..-XL, RCJ..-XL, RCJY..-XL,  
RCJL..-XL, RCJO..-XL, TCJ..-XL, PCF..-XL



PME(Y)..-XL, RME(Y)..-XL,  
RMEO..-XL, TME..-XL



RFE..-XL, TFE..-XL



PCCJ



## Product overview

## Housing units with flake graphite cast iron housing

### Take-up housing units

For linear motion or swivel motion

PTUE(Y)..-XL, RTUE(Y)..-XL,  
RTUEO..-XL, TTUE..-XL



PHE..-XL, PHEY..-XL, RHE..-XL,  
THE..-XL



PSFT..-XL



Guide tube, with adjusting screw

PHUSE..-XL



**Accessories**  
End caps

KASK



0008C1F8







Possible combinations Radial insert ball bearings with cast iron housings		Housing				
		Plummer block housing		Two-bolt flanged housing		Three-bolt flanged housing
						
Designation		<b>ASE</b>	<b>SHE</b>	<b>LCTE<sup>1)</sup></b>	<b>CJT</b>	<b>CFTR</b>
Shaft diameter d		<b>SAO<sup>2)</sup></b>		<b>GLCTE</b>	<b>CFT</b>	
					<b>CJTZ</b>	
<b>RAE...-XL-NPP-B</b> 12 mm – 50 mm				<b>FLCTE...-XL<sup>1)</sup></b> page 258		
<b>GRAE...-XL-NPP-B</b> 12 mm – 60 mm		<b>PASE...-XL</b> page 244	<b>PSHE...-XL</b> page 254	<b>GLCTE...-XL</b> page 258	<b>PC(J, F)T...-XL</b> page 262	<b>PCFTR...-XL</b> page 272
<b>GRA...-NPP-B-AS2/V</b> <i>5/8" – 1 15/16"</i>		Available by agreement	Available by agreement	Available by agreement	Available by agreement	Available by agreement
<b>GE...-XL-KRR-B</b> 17 mm – 120 mm		<b>RASE...-XL</b> page 244	<b>RSHE...-XL</b> page 254		<b>RCJT(Z)...-XL</b> page 262, 270	Available by agreement
<b>G...-KRR-B-AS2/V</b> <i>5/8" – 2 15/16"</i>		Available by agreement	Available by agreement		Available by agreement	
<b>GE...-XL-KTT-B</b> 20 mm – 80 mm		<b>TASE...-XL</b> page 244	<b>TSHE...-XL</b> page 254		<b>TCJT...-XL</b> page 262	Available by agreement
<b>GE...-XL-KLL-B</b> 20 mm – 50 mm		<b>LASE...-XL</b> page 244	Available by agreement		<b>LCJT...-XL</b> page 262	Available by agreement
<b>GNE...-XL-KRR-B<sup>2)</sup></b> 30 mm – 100 mm		<b>RSAO...-XL</b> page 246				
<b>GLE...-XL-KRR-B</b> 20 mm – 70 mm		<b>RASEL...-XL</b> page 244	Available by agreement		Available by agreement	Available by agreement
<b>GSH...-XL-2RSR-B</b> 20 mm – 50 mm		<b>RASEA...-XL</b> page 244	Available by agreement		<b>RCJTA...-XL</b> page 262	Available by agreement
<b>AY...-XL-NPP-B</b> 12 mm – 30 mm				<b>FLCTEY...-XL<sup>1)</sup></b> page 258		
<b>GAY...-XL-NPP-B</b> 12 mm – 60 mm		<b>PASEY...-XL</b> page 244	<b>PSHEY...-XL</b> page 254	<b>FLCTEY...-XL<sup>1)</sup></b> page 258	<b>PCJTY...-XL</b> page 262	Available by agreement
<b>GAY...-NPP-B(-AS2/V)</b> <i>1 1/2" – 1 7/16"</i>		Available by agreement	Available by agreement	Available by agreement	Available by agreement	
<b>GYE...-XL-KRR-B</b> 12 mm – 90 mm		<b>RASEY...-XL</b> page 244	<b>RSHEY...-XL</b> page 254		<b>RCJTY...-XL</b> page 262	Available by agreement
<b>GY...-KRR-B-AS2/V</b> <i>1 1/2" – 2 15/16"</i>		Available by agreement	Available by agreement		Available by agreement	

Catalogue range, dimension table, see pages indicated.  
Other dimensions and combinations available by agreement.

 Combinations not possible or not advisable.

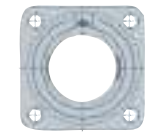
1) Without lubrication hole.

2) Heavy series.

Four-bolt flanged housing		Take-up housing			
					
<b>ME</b>	<b>CJ</b>	<b>TUE</b>	<b>HUE GEH..-HUSE</b>	<b>HE</b>	<b>SFT</b>
<b>MEO<sup>2)</sup></b>	<b>CJO<sup>2)</sup></b>	<b>TUEO<sup>2)</sup></b>			
<b>FE</b>	<b>CF</b>				
<b>PME..-XL</b> page 284	<b>PCJ..-XL, PCF..-XL</b> page 274	<b>PTUE..-XL</b> page 294	<b>PHUSE..-XL</b> page 302	<b>PHE..-XL</b> page 300	<b>PSFT...-XL</b> page 304
Available by agreement	Available by agreement	Available by agreement	Available by agreement	Available by agreement	Available by agreement
<b>RME..-XL, RFE..-XL</b> page 284, 290	<b>RCJ..-XL</b> page 274	<b>RTUE..-XL</b> page 294	Available by agreement	<b>RHE..-XL</b> page 300	Available by agreement
Available by agreement	Available by agreement	Available by agreement		Available by agreement	
<b>TME..-XL</b> page 284	<b>TCJ..-XL</b> page 274	<b>TTUE..-XL</b> page 294	Available by agreement	<b>THE..-XL</b> page 300	Available by agreement
<b>TFE..-XL</b> page 290					
Available by agreement	Available by agreement	Available by agreement	Available by agreement	Available by agreement	Available by agreement
<b>RMEO..-XL</b> page 284	<b>RCJO..-XL</b> page 278	<b>RTUEO..-XL</b> page 296			
Available by agreement	<b>RCJL..-XL</b> page 278	Available by agreement	Available by agreement	Available by agreement	Available by agreement
Available by agreement	Available by agreement	Available by agreement	Available by agreement	Available by agreement	Available by agreement
<b>PMEY..-XL</b> page 284	<b>PCJY..-XL</b> page 274	<b>PTUEY..-XL</b> page 294	Available by agreement	<b>PHEY..-XL</b> page 300	Available by agreement
Available by agreement	Available by agreement	Available by agreement		Available by agreement	
<b>RMEY..-XL</b> page 284	<b>RCJY..-XL</b> page 274	<b>RTUEY..-XL</b> page 294	Available by agreement	Available by agreement	Available by agreement
Available by agreement	Available by agreement	Available by agreement			



# Housing units with flake graphite cast iron housing

## Features

INA housing units are available as plummer block, flanged and take-up housing units in numerous different designs. The units are ready-to-fit and comprise INA flake graphite cast iron housings in which INA radial insert ball bearings are fitted.

Due to the spherical bearing outer ring and the concave housing bore, housing units can compensate for static angular misalignment of the shaft, see page 240.

The housings are screw mounted on the adjacent construction. Less stringent tolerances are sufficient for the screw mounting surfaces, see page 241.

Cast iron housings are single-piece units with high load carrying capacity, see page 241.



In order to ensure function and reliability under all operating conditions, the bearings and housings are matched to each other with a defined swivel moment after mounting.

All catalogue cast iron units have a mean swivel moment (as standard); further designs with a smaller or greater swivel moment, depending on their application, are available by agreement.

## X-life

Numerous sizes are supplied in the X-life design. These products are indicated in the dimension tables.

Radial insert ball bearings of X-life quality have, for example, lower roughness Ra and higher geometrical accuracy of the raceways than comparable designs that are not X-life. As a result, these bearings have higher load carrying capacity and longer rating life although their dimensions are identical. In certain applications, this means that a smaller bearing arrangement can be designed.

Radial insert ball bearings of X-life quality have an eccentric locking collar of an improved design and the quantity and distribution of the lubricant has been optimised. Housings ASE have additional crosspieces on the underside. For extreme requirements, the cage and seal material in the high and low temperature designs (suffix FA101) has been significantly improved in comparison with earlier versions.

## Plummer block housing units

Plummer block housing units have a long or a short base, *Figure 1*. Housings with a long base are screw mounted to the adjacent construction by means of slots, housings with a short base by blind threaded holes.

PASE..-XL

*Figure 1*  
Plummer block housing unit,  
flake graphite cast iron housing,  
with long base

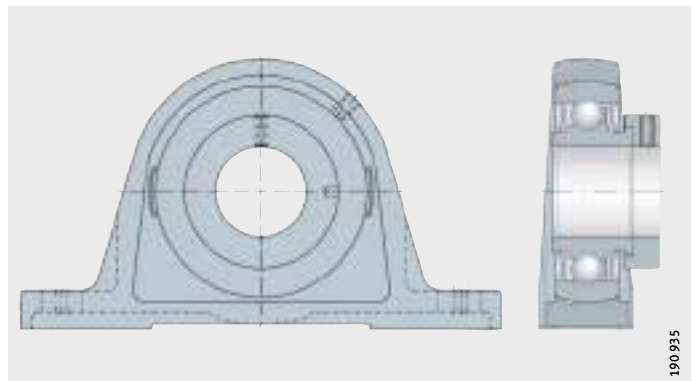

## Flanged housing units

Flanged housing units are available as two-bolt, three-bolt and four-bolt units, *Figure 2*. The housings are oval, triangular, square or round in shape. The housings have through holes for location purposes. Some series also have a centring spigot. The centring spigot is mounted in a turned recess in the machine structure. This gives concentric alignment of the housings and relieves the fixing screws of any radial forces.

PCJT...XL

*Figure 2*  
Flanged housing unit,  
flake graphite cast iron housing

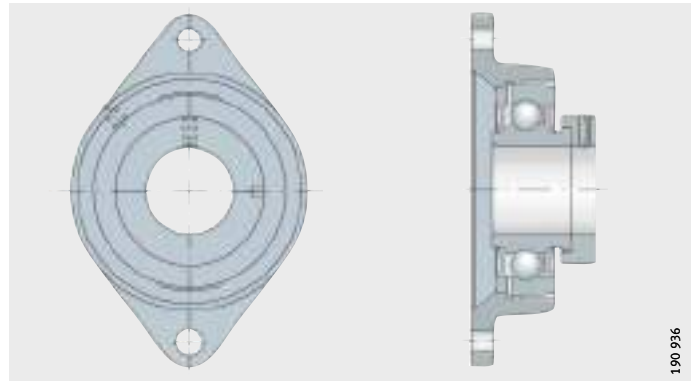

## Take-up housing units

Take-up housing units have facilities for sliding or swivel motion, *Figure 3*. They are used where shafts must undergo substantial displacement travel.

PTUE...XL

*Figure 3*  
Take-up housing unit,  
flake graphite cast iron housing

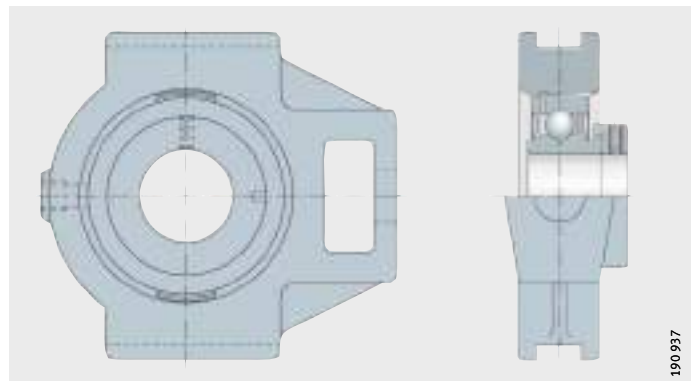

## Housing materials

The material used for the flake graphite cast iron housings is cast iron in accordance with DIN EN 1561. Housings are also available by agreement in spheroidal graphite cast iron in accordance with DIN EN 1563.

## Bearing end caps

In order to cover the exposed ends of rotating shafts, cast iron housings with the suffix N can also be fitted with bearing end caps, see page 242.

# Housing units with flake graphite cast iron housing

## Operating temperature

Housing units with bearing end caps are suitable for operating temperatures from  $-20\text{ }^{\circ}\text{C}$  to  $+80\text{ }^{\circ}\text{C}$ .

Housing units without bearing end caps are suitable for operating temperatures from  $-20\text{ }^{\circ}\text{C}$  to  $+100\text{ }^{\circ}\text{C}$ . Temporary temperature peaks are possible up to  $+120\text{ }^{\circ}\text{C}$ .

## Lubrication

For the relubrication of radial insert ball bearings, the housing bore has a radial groove and a lubrication hole suitable for conventional taper type lubrication nipples in accordance with DIN 71412.

The housing units are supplied with a kit or a lubrication nipple with a thread  $\text{Rp}^{1/8}$ .

The kit contains a lubrication nipple with a thread M6, a plastic end cap for the lubrication nipple and a plastic plug for the lubrication hole in the housing, *Figure 4*. Other kits are available by agreement.



For a lubrication nipple with thread M6, the maximum tightening torque  $M_A = 6\text{ Nm}$  must be observed.

In the case of housing units with the suffix FA125, FA101 and FA164, the lubrication nipple with the thread M6 is already fitted.

An additional kit is not included. This is also the case for radial insert ball bearings that have a labyrinth seal KLL and for radial insert ball bearings GLE that are used as non-locating bearings.

- ① Lubrication nipple
- ② Plastic end cap
- ③ Plastic plug

*Figure 4*  
Lubrication kit





## Corrosion-resistant units

Corrosion-resistant units are available as plummer block and flanged housing units. The housings and radial insert ball bearings have a Corrotect coating and the suffix FA125, see section Radial insert ball bearings and housing units, corrosion-resistant, page 349.

The units are used if moisture, contaminated water, salt spray mist, weakly alkaline or weakly acidic cleaning agents are present.

## Units for high and low temperatures

These units are available as plummer block and flanged housing units. The housings correspond to the cast iron housings described above. In addition, the high temperature design FA164 has a taper type lubrication nipple to DIN 71412 screwed into the housing.

Units for high temperatures have the suffix FA164 and units for the extended temperature range have the suffix FA101, see table, page 239, and table, page 146.

## Market sectors

In addition to the comprehensive catalogue range, we also supply housing units for special applications.

Examples include:

- corrosion-resistant flanged housing units with a two-piece housing
  - polypropylene flange, combined with corrosion-resistant high grade steel flange, see page 578
- units with plastic housings combined with radial insert ball bearings in a corrosion-resistant (VA) design or with bearings with a Corrotect coating, see page 426
- other designs with special greases or seals. Please contact us as necessary.

## Suffixes

Suffixes for available designs: see table.

## Available designs

Suffix	Description	Design
2C	Radial insert ball bearing with flinger shields on both sides	Standard
FA101	High and low temperature design –40 °C to +180 °C	
FA106	Bearing subjected to special noise testing	
FA107	Bearing with lubrication holes on the locating side	
FA125	With Corrotect coating	
FA164	High temperature design up to +250 °C	
N	Cast iron housing with undercut slot for end caps	
OSE	Bearing without clamping element	



## Housing units with flake graphite cast iron housing

### Design and safety guidelines

The chapter Technical principles brings together the essential guidelines on the design of bearing arrangements, lubrication, mounting and dismounting and the operation of bearings, see page 32.

INA radial insert ball bearings and INA housings are matched to each other and, as a unit, give particularly robust and economical bearing arrangements.

### Compensation of static misalignments

Bearings with a spherical outer ring, fitted in housings with a concave bore, can compensate for static misalignment of the shaft, *Figure 5*.

For units with a lubrication groove in the housing and lubrication hole in the radial insert ball bearing, the following applies:

- Up to  $\pm 2,5^\circ$ , the units can be relubricated.
- Between  $\pm 2,5^\circ$  and  $\pm 5^\circ$ , the possibility of relubrication is dependent on the specific unit. Please contact us in this case.
- Over  $\pm 5^\circ$ , relubrication is no longer possible.



The units must not be used to support swivelling or tumbling motion.



*Figure 5*  
Compensation  
of static shaft misalignment

### Speed limits for radial insert ball bearings

The speed limits are dependent on the load, the clearance between the bearing bore and shaft and the friction of the seals in bearings with contact seals, see page 148.

<b>Load carrying capacity of housings</b>	Due to their versatile characteristics, INA housing units can be easily used in almost all industrial sectors.
!	If bearing arrangements are planned for equipment in which a malfunction could be hazardous to persons or an unplanned stoppage of the machine could cause major disruption, it is essential that you consult us before proceeding with the design.
<b>Radial load carrying capacity</b>	Flake graphite cast iron housings can support the same radial loads as the radial insert ball bearings fitted. The static load carrying capacity $C_{0r}$ of the radial insert ball bearings is stated in the dimension tables.
!	Where shock loads are present, appropriate safety factors must be applied. In this case, please contact us. In the case of TUE...XL and TUEO...XL, the maximum radial tensile loading is only $0,25 \times C_{0r}$ (higher loads by agreement only).
<b>Axial load carrying capacity</b>	The axial load carrying capacity of flake graphite cast iron housings is restricted to $0,5 \times C_{0r}$ .
<b>Design of adjacent construction</b>	The permissible shaft tolerance is dependent on the speed, load and the radial insert ball bearing fitted. Shafts of the tolerance classes h6 $\text{\textcircled{E}}$ to h9 $\text{\textcircled{E}}$ can be used. Conventional drawn shafts will suffice for most applications.
<b>Screw mounting surfaces</b>	<p>Recommendations for the screw mounting surfaces are as follows:</p> <ul style="list-style-type: none"> <li>■ roughness of the screw mounting surface max. Ra 12,5 (Rzmax 63)</li> <li>■ geometrical and positional tolerance 0,04/100 concave, spherical not permissible.</li> <li>■ In the event of high loads occurring parallel to the mounting surface of plummer block housing units (in the case of cast iron housings with long base), the use of additional dowel pins to DIN EN ISO 8752 is recommended. In this case, through holes (see centre punch mark for housing ASE) must be applied, see <i>Figure 1</i>, page 129.</li> </ul>
<b>Fixing screws</b>	<p>The screw connection should be designed in accordance with VDI 2230; friction coefficient <math>\mu = 0,12</math> (90%).</p> <p>Screws of grade 8.8 or better can be used for fixing. The maximum tightening torques applicable to this screw grade must not be exceeded even if screws of a higher grade are used.</p> <p>In principle, we recommend that the screw connection should only be tightened to 70% of the values stated in the standard.</p> <p>For fixing, hexagonal socket head screws in accordance with DIN EN ISO 4762 or hexagonal socket head screws with a coarse pitch full thread in accordance with DIN EN ISO 4017 should be used. The screws should be combined as a minimum with a washer in accordance with DIN EN ISO 7089 or DIN EN ISO 7090.</p> <p>Screws and accessories for location are not included in the delivery.</p>



# Housing units with flake graphite cast iron housing

## Bearing end caps

The ends of shafts can be covered using bearing end caps made from acrylonitrile styrene acrylate copolymer (ASA), see table and *Figure 6*. The caps are suitable for temperatures from  $-20\text{ }^{\circ}\text{C}$  to  $+80\text{ }^{\circ}\text{C}$ . They protect against injury due to rotating shafts and also protect the bearings against contamination.

For location of the caps, housings with the suffix N have an annular slot on the entry side, see page 134.

The series for which end caps are supplied are indicated in the dimension tables. Bearing end caps are accessories and must always be ordered separately.



Housing units with the suffixes FA101 and FA164 are not suitable for combination with bearing end caps.

## End caps

Designation	Dimensions mm				
	d	D	H	L	E max.
<b>KASK04</b>	20	48	31	36	30
<b>KASK05</b>	25	54	33	38	30
<b>KASK06</b>	30	63	37	44	35
<b>KASK07</b>	35	73	39	47	39
<b>KASK08</b>	40	82	42	51	42
<b>KASK10</b>	50	92	47	56	46
<b>KASK12</b>	60	112	55	65	55

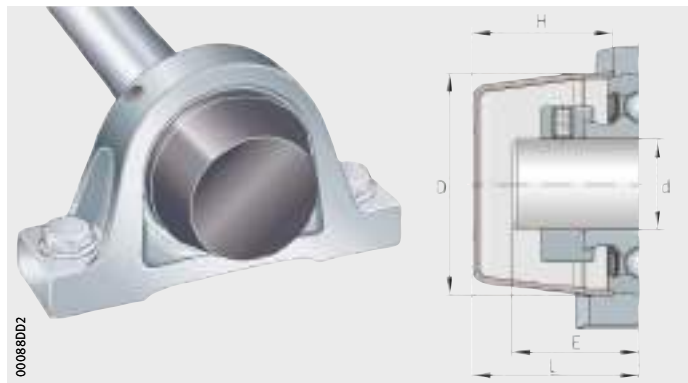

*Figure 6*  
Housing unit with bearing end cap

**Accuracy** The cast housings correspond predominantly to DIN 626-2 and ISO 3228, insofar as they are described therein.

The accuracy of the radial insert ball bearings fitted must be observed, see page 150.

**Dimensional tolerances** The dimensional tolerances for the machined surfaces of the flake graphite cast iron housings are  $\pm 0,25$  mm.

The dimensional tolerances for unmachined as well as machined to unmachined surfaces correspond to ISO 8062-3 (dimensional tolerance grade DCTG 9).



# Plummer block housing units

Flake graphite cast iron housing  
With long base  
Eccentric locking collar

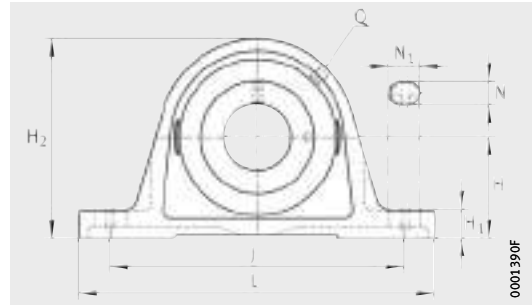

PASE...XL(-N), RASE...XL(-N,-FA164), TASE...XL-N,  
LASE...XL-N, RSAO...XL



**Dimension table** - Dimensions in mm

Designation			Mass m ≈ kg	Dimensions							
Unit	Housing	Radial insert ball bearing		d	H	J	L	A	A <sub>1</sub>	H <sub>1</sub>	H <sub>2</sub>
<b>PASE12-XL</b>	ASE03	GRAE12-XL-NPP-B	0,46	<b>12</b>	30,2	95	125	30	18	10	57
<b>PASE15-XL</b>	ASE03	GRAE15-XL-NPP-B	0,46	<b>15</b>	30,2	95	125	30	18	10	57
<b>PASE17-XL</b>	ASE03	GRAE17-XL-NPP-B	0,46	<b>17</b>	30,2	95	125	30	18	10	57
<b>RASE17-XL</b>	ASE03	GE17-XL-KRR-B	0,5	<b>17</b>	30,2	95	125	30	18	10	57
<b>PASE20-XL-N</b>	ASE04	GRAE20-XL-NPP-B	0,6	<b>20</b>	33,3	97	130	32	19	14,5	64
<b>LASE20-XL-N<sup>2)</sup></b>	ASE04	GE20-XL-KLL-B	0,63	<b>20</b>	33,3	97	130	32	19	14,5	64
<b>RASE20-XL-FA164<sup>2)</sup></b>	ASE04	GE20-XL-KRR-B-FA164	0,64	<b>20</b>	33,3	97	130	32	19	14,5	64
<b>RASE20-XL-N</b>	ASE04	GE20-XL-KRR-B	0,63	<b>20</b>	33,3	97	130	32	19	14,5	64
<b>TASE20-XL-N</b>	ASE04	GE20-XL-KTT-B	0,63	<b>20</b>	33,3	97	130	32	19	14,5	64
<b>PASE25-XL-N</b>	ASE05	GRAE25-XL-NPP-B	0,7	<b>25</b>	36,5	103	130	36	21	14,5	70
<b>LASE25-XL-N<sup>2)</sup></b>	ASE05	GE25-XL-KLL-B	0,76	<b>25</b>	36,5	103	130	36	21	14,5	70
<b>RASE25-XL-FA164<sup>2)</sup></b>	ASE05	GE25-XL-KRR-B-FA164	0,75	<b>25</b>	36,5	103	130	36	21	14,5	70
<b>RASE25-XL-N</b>	ASE05	GE25-XL-KRR-B	0,75	<b>25</b>	36,5	103	130	36	21	14,5	70
<b>TASE25-XL-N</b>	ASE05	GE25-XL-KTT-B	0,75	<b>25</b>	36,5	103	130	36	21	14,5	70
<b>PASE30-XL-N</b>	ASE06	GRAE30-XL-NPP-B	1,13	<b>30</b>	42,9	118	158	40	25	17	82
<b>LASE30-XL-N<sup>2)</sup></b>	ASE06	GE30-XL-KLL-B	1,2	<b>30</b>	42,9	118	158	40	25	17	82
<b>RASE30-XL-FA164<sup>2)</sup></b>	ASE06	GE30-XL-KRR-B-FA164	1,21	<b>30</b>	42,9	118	158	40	25	17	82
<b>RASE30-XL-N</b>	ASE06	GE30-XL-KRR-B	1,11	<b>30</b>	42,9	118	158	40	25	17	82
<b>TASE30-XL-N</b>	ASE06	GE30-XL-KTT-B	1,2	<b>30</b>	42,9	118	158	40	25	17	82
<b>RSAO30-XL</b>	SAO06	GNE30-XL-KRR-B	1,8	<b>30</b>	50	140	180	50	28	18	95
<b>PASE35-XL-N</b>	ASE07	GRAE35-XL-NPP-B	1,61	<b>35</b>	47,6	126	163	45	27	19	93
<b>LASE35-XL-N<sup>2)</sup></b>	ASE07	GE35-XL-KLL-B	1,64	<b>35</b>	47,6	126	163	45	27	19	93
<b>RASE35-XL-FA164<sup>2)</sup></b>	ASE07	GE35-XL-KRR-B-FA164	1,66	<b>35</b>	47,6	126	163	45	27	19	93
<b>RASE35-XL-N</b>	ASE07	GE35-XL-KRR-B	1,69	<b>35</b>	47,6	126	163	45	27	19	93
<b>TASE35-XL-N</b>	ASE07	GE35-XL-KTT-B	1,69	<b>35</b>	47,6	126	163	45	27	19	93
<b>RSAO35-XL</b>	SAO07	GNE35-XL-KRR-B	2,79	<b>35</b>	56	160	210	56	30	20	106

1) To be ordered separately.  
The caps are suitable for temperatures from -20 °C to +80 °C.

2) With fitted lubrication nipple.

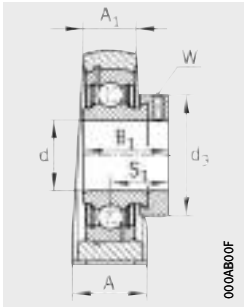

PASE...XL(-N)

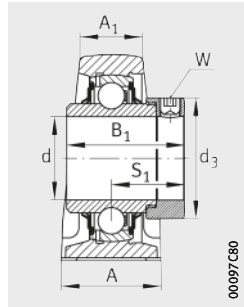

RASE..XL(-N,-FA164),  
RSAO...XL

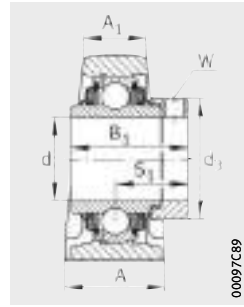

TASE...XL-N

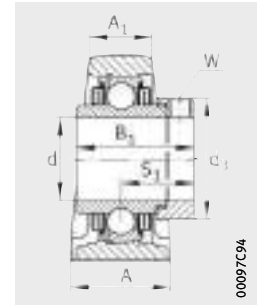

LASE...XL-N

N	N <sub>1</sub>	B <sub>1</sub>	S <sub>1</sub>	Q	d <sub>3</sub> max.	W	Load carrying capacity Bearing			End cap <sup>1)</sup>
							Basic load ratings		Fatigue limit load C <sub>ur</sub> N	
							dyn. C <sub>r</sub> N	stat. C <sub>0r</sub> N		
11	19	28,6	22,1	M6	28,4	3	10 100	4 750	241	–
11	19	28,6	22,1	M6	28,4	3	10 100	4 750	241	–
11	19	28,6	22,1	M6	28,4	3	10 100	4 750	241	–
11	19	37,4	23,5	M6	28,4	3	10 100	4 750	241	–
11	19	31	23,5	Rp <sup>1</sup> / <sub>8</sub>	33	3	13 600	6 600	335	KASK04
11	19	43,7	26,6	Rp <sup>1</sup> / <sub>8</sub>	33	3	13 600	6 600	335	KASK04
11	19	43,7	26,6	Rp <sup>1</sup> / <sub>8</sub>	33	3	13 600	6 600	335	–
11	19	43,7	26,6	Rp <sup>1</sup> / <sub>8</sub>	33	3	13 600	6 600	335	KASK04
11	19	43,7	26,6	Rp <sup>1</sup> / <sub>8</sub>	33	3	13 600	6 600	335	KASK04
11	19	31	23,5	Rp <sup>1</sup> / <sub>8</sub>	37,5	3	14 900	7 800	395	KASK05
11	19	44,5	27	Rp <sup>1</sup> / <sub>8</sub>	37,5	3	14 900	7 800	395	KASK05
11	19	44,5	27	Rp <sup>1</sup> / <sub>8</sub>	37,5	3	14 900	7 800	395	–
11	19	44,5	27	Rp <sup>1</sup> / <sub>8</sub>	37,5	3	14 900	7 800	395	KASK05
11	19	44,5	27	Rp <sup>1</sup> / <sub>8</sub>	37,5	3	14 900	7 800	395	KASK05
14	22	35,8	26,8	Rp <sup>1</sup> / <sub>8</sub>	44	4	20 700	11 300	570	KASK06
14	22	48,5	30,2	Rp <sup>1</sup> / <sub>8</sub>	44	4	20 700	11 300	570	KASK06
14	22	48,5	30,2	Rp <sup>1</sup> / <sub>8</sub>	44	4	20 700	11 300	570	–
14	22	48,5	30,2	Rp <sup>1</sup> / <sub>8</sub>	44	4	20 700	11 300	570	KASK06
14	22	48,5	30,2	Rp <sup>1</sup> / <sub>8</sub>	44	4	20 700	11 300	570	KASK06
17,5	20,5	50,2	32,7	M6	51	5	31 500	16 700	840	–
14	21	39	29,5	Rp <sup>1</sup> / <sub>8</sub>	55	5	27 500	15 300	770	KASK07
14	21	51,3	32,5	Rp <sup>1</sup> / <sub>8</sub>	55	5	27 500	15 300	770	KASK07
14	21	51,3	32,5	Rp <sup>1</sup> / <sub>8</sub>	55	5	27 500	15 300	770	–
14	21	51,3	32,5	Rp <sup>1</sup> / <sub>8</sub>	55	5	27 500	15 300	770	KASK07
14	21	51,3	32,5	Rp <sup>1</sup> / <sub>8</sub>	55	5	27 500	15 300	770	KASK07
17,5	25,5	51,6	33,3	M6	55	5	39 000	20 900	1 060	–



# Plummer block housing units

Flake graphite cast iron housing  
 With long base  
 Eccentric locking collar

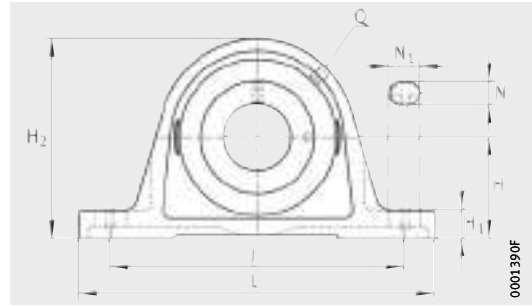

PASE...XL(-N), RASE...XL(-N,-FA164), TASE...XL(-N),  
 LASE...XL(-N), RSAO...XL



**Dimension table** (continued) · Dimensions in mm

Designation			Mass	Dimensions							
Unit	Housing	Radial insert ball bearing		d	H	J	L	A	A <sub>1</sub>	H <sub>1</sub>	H <sub>2</sub>
			m								
			≈ kg								
<b>PASE40-XL-N</b>	ASE08	GRAE40-XL-NPP-B	1,84	<b>40</b>	49,2	138	179	48	30	19	99
<b>RSAO40-XL</b>	SAO08	GNE40-XL-KRR-B	3,18	<b>40</b>	60	170	220	60	31	22	116
<b>LASE40-XL-N<sup>2)</sup></b>	ASE08	GE40-XL-KLL-B	1,97	<b>40</b>	49,2	138	179	48	30	19	99
<b>RASE40-XL-FA164<sup>2)</sup></b>	ASE08	GE40-XL-KRR-B-FA164	1,97	<b>40</b>	49,2	138	179	48	30	19	99
<b>RASE40-XL-N</b>	ASE08	GE40-XL-KRR-B	1,95	<b>40</b>	49,2	138	179	48	30	19	99
<b>TASE40-XL-N</b>	ASE08	GE40-XL-KTT-B	1,96	<b>40</b>	49,2	138	179	48	30	19	99
<b>PASE45-XL</b>	ASE09	GRAE45-XL-NPP-B	2,15	<b>45</b>	54	150	192	48	32	21,5	107
<b>LASE45-XL<sup>2)</sup></b>	ASE09	GE45-XL-KLL-B	2,3	<b>45</b>	54	150	192	48	32	21,5	107
<b>RASE45-XL</b>	ASE09	GE45-XL-KRR-B	2,28	<b>45</b>	54	150	192	48	32	21,5	107
<b>TASE45-XL</b>	ASE09	GE45-XL-KTT-B	2,28	<b>45</b>	54	150	192	48	32	21,5	107
<b>PASE50-XL-N</b>	ASE10	GRAE50-XL-NPP-B	2,59	<b>50</b>	57,2	158	200	54	34	21,5	115
<b>LASE50-XL-N<sup>2)</sup></b>	ASE10	GE50-XL-KLL-B	2,82	<b>50</b>	57,2	158	200	54	34	21,5	115
<b>RASE50-XL-FA164<sup>2)</sup></b>	ASE10	GE50-XL-KRR-B-FA164	2,82	<b>50</b>	57,2	158	200	54	34	21,5	115
<b>RASE50-XL-N</b>	ASE10	GE50-XL-KRR-B	2,8	<b>50</b>	57,2	158	200	54	34	21,5	115
<b>TASE50-XL-N</b>	ASE10	GE50-XL-KTT-B	2,8	<b>50</b>	57,2	158	200	54	34	21,5	115
<b>RSAO50-XL</b>	SAO10	GNE50-XL-KRR-B	6,1	<b>50</b>	75	212	275	75	39	27	143
<b>PASE55-XL</b>	ASE11	GRAE55-XL-NPP-B	2,79	<b>55</b>	63,5	176	222	60	35	22,5	124,5
<b>RASE55-XL</b>	ASE11	GE55-XL-KRR-B	3,4	<b>55</b>	63,5	176	222	60	35	22,5	124,5
<b>TASE55-XL</b>	ASE11	GE55-XL-KTT-B	3,51	<b>55</b>	63,5	176	222	60	35	22,5	124,5
<b>PASE60-XL-N</b>	ASE12	GRAE60-XL-NPP-B	4,35	<b>60</b>	69,9	190	240	60	42	25	140
<b>RSAO60-XL</b>	SAO12	GNE60-XL-KRR-B	9	<b>60</b>	85	250	330	85	46	32	165
<b>RASE60-XL-FA164<sup>2)</sup></b>	ASE12	GE60-XL-KRR-B-FA164	4,79	<b>60</b>	69,9	190	240	60	42	25	140
<b>RASE60-XL-N</b>	ASE12	GE60-XL-KRR-B	4,79	<b>60</b>	69,9	190	240	60	42	25	140
<b>TASE60-XL-N</b>	ASE12	GE60-XL-KTT-B	4,77	<b>60</b>	69,9	190	240	60	42	25	140
<b>RASE65-214-XL<sup>3)</sup></b>	ASE14	GE65-214-XL-KRR-B	6,41	<b>65</b>	79,4	203	260	65	44	27,5	156
<b>TASE65-214-XL<sup>3)</sup></b>	ASE14	GE65-214-XL-KTT-B	6,41	<b>65</b>	79,4	203	260	65	44	27,5	156

1) To be ordered separately.  
 The caps are suitable for temperatures from -20 °C to +80 °C.  
 2) With fitted lubrication nipple.  
 3) Alternative ball set 6214.



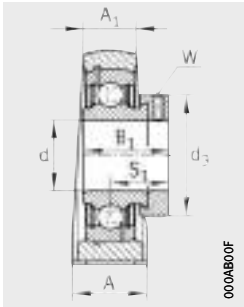

PASE...XL(-N)

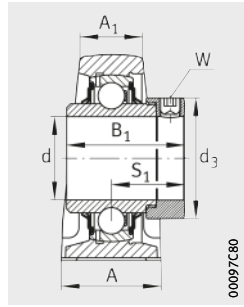

RASE..-XL(-N,-FA164),  
RSAO...-XL

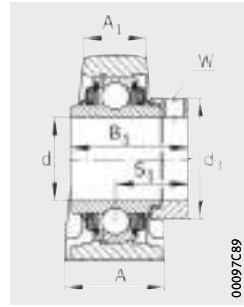

TASE...XL(-N)

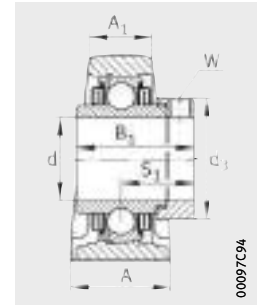

LASE...XL(-N)

N	N <sub>1</sub>	B <sub>1</sub>	S <sub>1</sub>	Q	d <sub>3</sub> max.	W	Load carrying capacity Bearing			End cap <sup>1)</sup>
							Basic load ratings		Fatigue limit load C <sub>ur</sub> N	
							dyn. C <sub>r</sub> N	stat. C <sub>0r</sub> N		
14	26	43,8	32,8	Rp <sup>1/8</sup>	58	5	34 500	19 800	1 010	KASK08
17,5	27,5	54,6	36,6	M6	63	5	47 000	26 000	1 320	-
14	26	56,5	35,1	Rp <sup>1/8</sup>	58	5	34 500	19 800	1 010	KASK08
14	26	56,5	35,1	Rp <sup>1/8</sup>	58	5	34 500	19 800	1 010	-
14	26	56,5	35,1	Rp <sup>1/8</sup>	58	5	34 500	19 800	1 010	KASK08
14	26	56,5	35,1	Rp <sup>1/8</sup>	58	5	34 500	19 800	1 010	KASK08
14	29	43,8	32,8	M6	63	5	34 500	20 400	1 030	-
14	29	56,5	35,1	M6	63	5	34 500	20 400	1 030	-
14	29	56,5	35,1	M6	63	5	34 500	20 400	1 030	-
14	29	56,5	35,1	M6	63	5	34 500	20 400	1 030	-
18	23	43,8	32,8	Rp <sup>1/8</sup>	69	5	37 500	23 200	1 180	KASK10
18	23	62,8	38,2	Rp <sup>1/8</sup>	69	5	37 500	23 200	1 180	KASK10
18	23	62,8	38,2	Rp <sup>1/8</sup>	69	5	37 500	23 200	1 180	-
18	23	62,8	38,2	Rp <sup>1/8</sup>	69	5	37 500	23 200	1 180	KASK10
18	23	62,8	38,2	Rp <sup>1/8</sup>	69	5	37 500	23 200	1 180	KASK10
20	35	66,75	42,15	M6	75,8	5	66 000	38 000	1 920	-
18	30	48,4	36,4	M6	76	5	46 000	29 000	1 480	-
18	30	71,4	43,6	M6	76	5	46 000	29 000	1 480	-
18	30	71,4	43,6	M6	76	5	46 000	29 000	1 480	-
18	28	53,1	39,6	Rp <sup>1/8</sup>	84	5	56 000	36 000	1 820	KASK12
25	38	68	45	Rp <sup>1/8</sup>	89	5	87 000	52 000	2 650	-
18	28	77,9	46,9	Rp <sup>1/8</sup>	84	5	56 000	36 000	1 820	-
18	28	77,9	46,9	Rp <sup>1/8</sup>	84	5	56 000	36 000	1 820	KASK12
18	28	77,9	46,9	Rp <sup>1/8</sup>	84	5	56 000	36 000	1 820	KASK12
22	28	66	44,5	Rp <sup>1/8</sup>	96	6	66 000	44 000	2 230	-
22	28	66	44,5	Rp <sup>1/8</sup>	96	6	66 000	44 000	2 230	-



# Plummer block housing units

Flake graphite cast iron housing  
 With long base  
 Eccentric locking collar

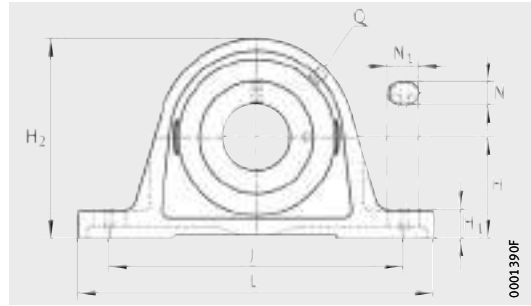

RASE...XL(-FA164), TASE...XL, RSAO...XL



**Dimension table** (continued) · Dimensions in mm

Designation			Mass m ≈ kg	Dimensions					
Unit	Housing	Radial insert ball bearing		d	H	J	L	A	A <sub>1</sub>
<b>RASE70-XL</b>	ASE14	GE70-XL-KRR-B	6,15	<b>70</b>	79,4	203	260	65	44
<b>RASE70-XL-FA164<sup>1)</sup></b>	ASE14	GE70-XL-KRR-B-FA164	6,15	<b>70</b>	79,4	203	260	65	44
<b>TASE70-XL</b>	ASE14	GE70-XL-KTT-B	6,09	<b>70</b>	79,4	203	260	65	44
<b>RSAO70-XL</b>	SAO14	GNE70-XL-KRR-B	11	<b>70</b>	95	282	360	90	54
<b>RASE75-XL</b>	ASE15	GE75-XL-KRR-B	6,58	<b>75</b>	82,5	210	265	66	48
<b>RASE75-XL-FA164<sup>1)</sup></b>	ASE15	GE75-XL-KRR-B-FA164	7,65	<b>75</b>	82,5	210	265	66	48
<b>TASE75-XL</b>	ASE15	GE75-XL-KTT-B	7,65	<b>75</b>	82,5	210	265	66	48
<b>RASE80-XL</b>	ASE16	GE80-XL-KRR-B	8,65	<b>80</b>	89	232	290	78	55
<b>RASE80-XL-AH01-FA164<sup>1)</sup></b>	ASE16	GE80-XL-KRR-B-AH01-FA164	8,65	<b>80</b>	89	232	290	78	55
<b>TASE80-XL</b>	ASE16	GE80-XL-KTT-B	8,49	<b>80</b>	89	232	290	78	55
<b>RSAO80-XL</b>	SAO16	GNE80-XL-KRR-B	22,5	<b>80</b>	116	315	390	110	76
<b>RASE90-XL</b>	ASE18	GE90-XL-KRR-B	12,12	<b>90</b>	101,6	268	330	85	55
<b>RASE90-XL-FA164<sup>1)</sup></b>	ASE18	GE90-XL-KRR-B-FA164	12,12	<b>90</b>	101,6	268	330	85	55
<b>RSAO90-XL</b>	SAO18	GNE90-XL-KRR-B	29,5	<b>90</b>	130	340	410	120	84
<b>RASE100-XL</b>	ASE20	GE100-XL-KRR-B	15,85	<b>100</b>	115	308	380	95	62
<b>RSAO100-XL</b>	SAO20	GNE100-XL-KRR-B	41	<b>100</b>	145	375	440	130	94
<b>RASE120-XL</b>	ASE24	GE120-XL-KRR-B	26,52	<b>120</b>	135	358	440	105	70

<sup>1)</sup> With fitted lubrication nipple.

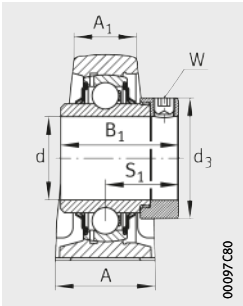

RASE...XL(-FA164),  
RSAO...XL

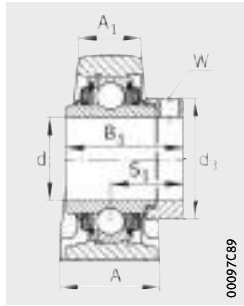

TASE...XL

								Width across flats W	Load carrying capacity Bearing		
									Basic load ratings		Fatigue limit load $C_{ur}$ N
									dyn. $C_r$ N	stat. $C_{Or}$ N	
$H_1$	$H_2$	N	$N_1$	$B_1$	$S_1$	Q	$d_3$ max.				
27,5	156	22	28	66	44,5	Rp1/8	96	6	66 000	44 000	2 230
27,5	156	22	28	66	44,5	Rp1/8	96	6	66 000	44 000	2 230
27,5	156	22	28	66	44,5	Rp1/8	96	6	66 000	44 000	2 230
35	187	27	42	75,5	49,5	M6	102	6	111 000	68 000	3 300
27,5	164	22	30	67	45,5	M6	100	6	66 000	44 500	2 240
27,5	164	22	30	67	45,5	M6	100	6	66 000	44 500	2 240
27,5	164	22	30	67	45,5	M6	100	6	66 000	44 500	2 240
30	175	26	34	70,7	47,3	Rp1/8	108	6	76 000	54 000	2 600
30	175	26	34	70,7	47,3	Rp1/8	108	6	76 000	54 000	2 600
30	175	26	34	70,7	47,3	Rp1/8	108	6	76 000	54 000	2 600
50	226	25,5	44,5	93,6	59,6	M6	118	6	131 000	87 000	3 950
35	200	27	35	69,5	46,5	M6	118	6	109 000	79 000	3 550
35	200	27	35	69,5	46,5	M6	118	6	109 000	79 000	3 550
57	250	28	54	101	65,5	M6	132	6	151 000	107 000	4 600
40	225	30	38	75	49,5	M6	132	6	130 000	93 000	4 000
65	280	32	47	109,4	69,9	Rp1/8	145	6	184 000	141 000	5 700
45	265	33	41	81	52,5	M6	152	6	165 000	131 000	5 100



# Plummer block housing units

Flake graphite cast iron housing  
 With long base  
 Grub screws in inner ring

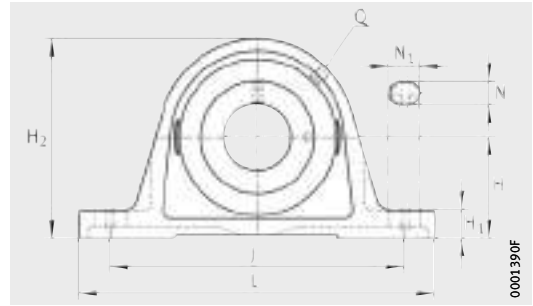

PASEY..-XL(-N), RASEY..-XL(-N)



**Dimension table** - Dimensions in mm

Designation			Mass  m  ≈ kg	Dimensions						
Unit	Housing	Radial insert ball bearing		d	H	J	L	A	A <sub>1</sub>	H <sub>1</sub>
<b>PASEY12-XL</b>	ASE03	GAY12-XL-NPP-B	0,44	<b>12</b>	30,2	95	125	30	18	10
<b>RASEY12-XL</b>	ASE03	GYE12-XL-KRR-B	0,45	<b>12</b>	30,2	95	125	30	18	10
<b>PASEY15-XL</b>	ASE03	GAY15-XL-NPP-B	0,43	<b>15</b>	30,2	95	125	30	18	10
<b>RASEY15-XL</b>	ASE03	GYE15-XL-KRR-B	0,45	<b>15</b>	30,2	95	125	30	18	10
<b>RASEY16-XL</b>	ASE03	GYE16-XL-KRR-B	0,45	<b>16</b>	30,2	95	125	30	18	10
<b>PASEY17-XL</b>	ASE03	GAY17-XL-NPP-B	0,42	<b>17</b>	30,2	95	125	30	18	10
<b>RASEY17-XL</b>	ASE03	GYE17-XL-KRR-B	0,45	<b>17</b>	30,2	95	125	30	18	10
<b>PASEY20-XL-N</b>	ASE04	GAY20-XL-NPP-B	0,56	<b>20</b>	33,3	97	130	32	19	14,5
<b>RASEY20-XL-N</b>	ASE04	GYE20-XL-KRR-B	0,58	<b>20</b>	33,3	97	130	32	19	14,5
<b>PASEY25-XL-N</b>	ASE05	GAY25-XL-NPP-B	0,61	<b>25</b>	36,5	103	130	36	21	14,5
<b>RASEY25-XL-N</b>	ASE05	GYE25-XL-KRR-B	0,7	<b>25</b>	36,5	103	130	36	21	14,5
<b>PASEY30-XL-N</b>	ASE06	GAY30-XL-NPP-B	1,07	<b>30</b>	42,9	118	158	40	25	17
<b>RASEY30-XL-N</b>	ASE06	GYE30-XL-KRR-B	1,13	<b>30</b>	42,9	118	158	40	25	17
<b>PASEY35-XL-N</b>	ASE07	GAY35-XL-NPP-B	1,45	<b>35</b>	47,6	126	163	45	27	19
<b>RASEY35-XL-N</b>	ASE07	GYE35-XL-KRR-B	1,55	<b>35</b>	47,6	126	163	45	27	19
<b>PASEY40-XL-N</b>	ASE08	GAY40-XL-NPP-B	1,75	<b>40</b>	49,2	138	179	48	30	19
<b>RASEY40-XL-N</b>	ASE08	GYE40-XL-KRR-B	1,84	<b>40</b>	49,2	138	179	48	30	19
<b>PASEY45-XL</b>	ASE09	GAY45-XL-NPP-B	2,06	<b>45</b>	54	150	192	48	32	21,5
<b>RASEY45-XL</b>	ASE09	GYE45-XL-KRR-B	2,16	<b>45</b>	54	150	192	48	32	21,5
<b>PASEY50-XL-N</b>	ASE10	GAY50-XL-NPP-B	2,49	<b>50</b>	57,2	158	200	54	34	21,5
<b>RASEY50-XL-N</b>	ASE10	GYE50-XL-KRR-B	2,6	<b>50</b>	57,2	158	200	54	34	21,5
<b>RASEY55-XL</b>	ASE11	GYE55-XL-KRR-B	3,22	<b>55</b>	63,5	176	222	60	35	22,5
<b>PASEY60-XL-N</b>	ASE12	GAY60-XL-NPP-B	4,15	<b>60</b>	69,9	190	240	60	42	25
<b>RASEY60-XL-N</b>	ASE12	GYE60-XL-KRR-B	4,27	<b>60</b>	69,9	190	240	60	42	25
<b>RASEY65-214-XL<sup>2)</sup></b>	ASE14	GYE65-214-XL-KRR-B	5,95	<b>65</b>	79,4	203	260	65	44	27,5
<b>RASEY70-XL</b>	ASE14	GYE70-XL-KRR-B	5,93	<b>70</b>	79,4	203	260	65	44	27,5
<b>RASEY75-XL</b>	ASE15	GYE75-XL-KRR-B	6,51	<b>75</b>	82,5	210	265	66	48	27,5
<b>RASEY80-XL</b>	ASE16	GYE80-XL-KRR-B	8,41	<b>80</b>	89	232	290	78	55	30
<b>RASEY90-XL</b>	ASE18	GYE90-XL-KRR-B	12,6	<b>90</b>	101,6	268	330	85	55	35

1) To be ordered separately.  
 The caps are suitable for temperatures from -20 °C to +80 °C.

2) Alternative ball set 6214.

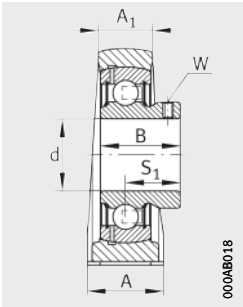

PASEY..XL(-N)

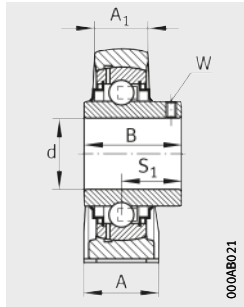

RASEY..XL(-N)

H <sub>2</sub>	N	N <sub>1</sub>	B	S <sub>1</sub>	Q	W	Load carrying capacity Bearing			End cap <sup>1)</sup>
							Basic load ratings		Fatigue limit load C <sub>ur</sub> N	
							dyn. C <sub>r</sub> N	stat. C <sub>0r</sub> N		
57	11	19	22	16	M6	2,5	10 100	4 750	241	–
57	11	19	27,4	15,9	M6	2,5	10 100	4 750	241	–
57	11	19	22	16	M6	2,5	10 100	4 750	241	–
57	11	19	27,4	15,9	M6	2,5	10 100	4 750	241	–
57	11	19	27,4	15,9	M6	2,5	10 100	4 750	241	–
57	11	19	22	16	M6	2,5	10 100	4 750	241	–
57	11	19	27,4	15,9	M6	2,5	10 100	4 750	241	–
64	11	19	25	18	Rp <sup>1/8</sup>	2,5	13 600	6 600	335	KASK04
64	11	19	31	18,3	Rp <sup>1/8</sup>	2,5	13 600	6 600	335	KASK04
70	11	19	27	19,5	Rp <sup>1/8</sup>	2,5	14 900	7 800	395	KASK05
70	11	19	34,1	19,8	Rp <sup>1/8</sup>	2,5	14 900	7 800	395	KASK05
82	14	22	30	21	Rp <sup>1/8</sup>	3	20 700	11 300	570	KASK06
82	14	22	38,1	22,2	Rp <sup>1/8</sup>	3	20 700	11 300	570	KASK06
93	14	21	35	25,5	Rp <sup>1/8</sup>	3	27 500	15 300	770	KASK07
93	14	21	42,9	25,4	Rp <sup>1/8</sup>	3	27 500	15 300	770	KASK07
99	14	26	39,5	29	Rp <sup>1/8</sup>	4	34 500	19 800	1 010	KASK08
99	14	26	49,2	30,2	Rp <sup>1/8</sup>	4	34 500	19 800	1 010	KASK08
107	14	29	41,5	30,5	M6	4	34 500	20 400	1 030	–
107	14	29	49,2	30,2	M6	4	34 500	20 400	1 030	–
115	18	23	43	32	Rp <sup>1/8</sup>	4	37 500	23 200	1 180	KASK10
115	18	23	51,6	32,6	Rp <sup>1/8</sup>	4	37 500	23 200	1 180	KASK10
124,5	18	30	55,6	33,4	M6	4	46 000	29 000	1 480	–
140	18	28	47	34	Rp <sup>1/8</sup>	5	56 000	36 000	1 820	KASK12
140	18	28	65,1	39,7	Rp <sup>1/8</sup>	5	56 000	36 000	1 820	KASK12
156	22	28	74,6	44,4	Rp <sup>1/8</sup>	5	66 000	44 000	2 230	–
156	22	28	74,6	44,4	Rp <sup>1/8</sup>	5	66 000	44 000	2 230	–
164	22	30	77,8	44,5	M6	5	66 000	44 500	2 240	–
175	26	35	82,6	49,3	Rp <sup>1/8</sup>	5	76 000	54 000	2 600	–
200	27	35	96	56,3	M6	6	109 000	79 000	3 550	–



# Plummer block housing units

Flake graphite cast iron housing  
 With long base  
 Adapter sleeve or drive slot

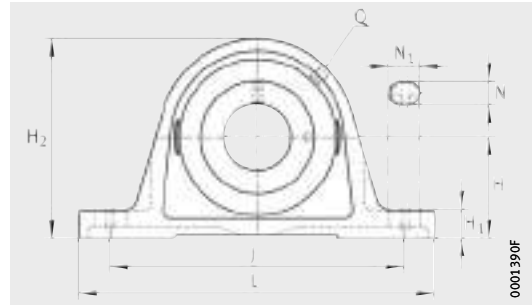

RASEA...-XL-N, RASEL...-XL(-N)



**Dimension table** - Dimensions in mm

Designation			Mass m ≈ kg	Dimensions					
Unit	Housing	Radial insert ball bearing		d	H	J	L	A	A <sub>1</sub>
<b>RASEA20-XL-N</b>	ASE04	GSH20-XL-2RSR-B	0,51	<b>20</b>	33,3	97	130	32	19
<b>RASEA25-XL-N</b>	ASE05	GSH25-XL-2RSR-B	0,6	<b>25</b>	36,5	103	130	36	21
<b>RASEA30-XL-N</b>	ASE06	GSH30-XL-2RSR-B	1	<b>30</b>	42,9	118	158	40	25
<b>RASEA35-XL-N</b>	ASE07	GSH35-XL-2RSR-B	1,48	<b>35</b>	47,6	126	163	45	27
<b>RASEA40-XL-N</b>	ASE08	GSH40-XL-2RSR-B	1,71	<b>40</b>	49,2	138	179	48	30
<b>RASEA50-XL-N</b>	ASE10	GSH50-XL-2RSR-B	2,09	<b>50</b>	57,2	158	200	54	34

**Dimension table** - Dimensions in mm

Designation			Mass m ≈ kg	Dimensions					
Unit <sup>2)</sup>	Housing	Radial insert ball bearing		d	H	J	L	A	A <sub>1</sub>
<b>RASEL20-XL-N</b>	ASE04	GLE20-XL-KRR-B	0,58	<b>20</b>	33,3	97	130	32	19
<b>RASEL25-XL-N</b>	ASE05	GLE25-XL-KRR-B	0,7	<b>25</b>	36,5	103	130	36	21
<b>RASEL30-XL-N</b>	ASE06	GLE30-XL-KRR-B	1,1	<b>30</b>	42,9	118	158	40	25
<b>RASEL40-XL-N</b>	ASE08	GLE40-XL-KRR-B	1,79	<b>40</b>	49,2	138	179	48	30
<b>RASEL45-XL</b>	ASE09	GLE45-XL-KRR-B	2,1	<b>45</b>	54	150	192	48	32
<b>RASEL50-XL-N</b>	ASE10	GLE50-XL-KRR-B	2,6	<b>50</b>	57,2	158	200	54	34
<b>RASEL60-XL-N</b>	ASE12	GLE60-XL-KRR-B	4,43	<b>60</b>	69,9	190	240	60	42
<b>RASEL70-XL</b>	ASE14	GLE70-XL-KRR-B	5,87	<b>70</b>	79,4	203	260	65	44

1) To be ordered separately.  
 The caps are suitable for temperatures from -20 °C to +80 °C.

2) With fitted lubrication nipple.

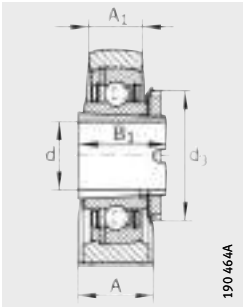

RASEA...XL-N

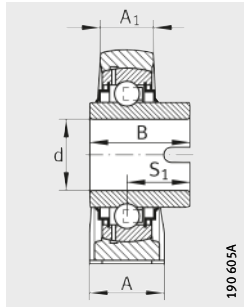

RASEL...XL(-N)

								Load carrying capacity Bearing			End cap <sup>1)</sup>
								Basic load ratings		Fatigue limit load C <sub>ur</sub> N	
H <sub>1</sub>	H <sub>2</sub>	N	N <sub>1</sub>	B <sub>1</sub>	S <sub>1</sub>	Q	d <sub>3</sub> max.	dyn. C <sub>r</sub> N	stat. C <sub>0r</sub> N		
14,5	64	11	19	28	20,5	Rp <sup>1/8</sup>	32	13 400	7 000	355	KASK04
14,5	70	11	19	28	20,5	Rp <sup>1/8</sup>	38	14 400	8 100	410	KASK05
17	82	14	22	32	23	Rp <sup>1/8</sup>	45	20 100	11 600	590	KASK06
19	93	14	21	34	24,5	Rp <sup>1/8</sup>	52	26 500	15 700	800	KASK07
19	99	14	26	38	27	Rp <sup>1/8</sup>	58	31 000	19 700	1 000	KASK08
21,5	115	18	23	40	29	Rp <sup>1/8</sup>	70	35 000	23 100	1 170	KASK10

								Load carrying capacity Bearing			End cap <sup>1)</sup>
								Basic load ratings		Fatigue limit load C <sub>ur</sub> N	
H <sub>1</sub>	H <sub>2</sub>	N	N <sub>1</sub>	B	S <sub>1</sub>	Q	dyn. C <sub>r</sub> N	stat. C <sub>0r</sub> N			
14,5	64	11	19	34,1	18,5	Rp <sup>1/8</sup>	13 600	6 600	335	KASK04	
14,5	70	11	19	34,9	20,2	Rp <sup>1/8</sup>	14 900	7 800	395	KASK05	
17	82	14	22	36,5	22	Rp <sup>1/8</sup>	20 700	11 300	570	KASK06	
19	99	14	26	42,9	27	Rp <sup>1/8</sup>	34 500	19 800	1 010	KASK08	
21,5	107	14	29	42,9	25,5	M6	34 500	20 400	1 030	–	
21,5	115	18	23	49,2	30,2	Rp <sup>1/8</sup>	37 500	23 200	1 180	KASK10	
25	140	18	28	61,9	37,3	Rp <sup>1/8</sup>	56 000	36 000	1 820	KASK12	
27,5	156	22	28	68,2	41,2	Rp <sup>1/8</sup>	66 000	44 000	2 230	–	



# Plummer block housing units

Flake graphite cast iron housing  
 With short base  
 With eccentric locking collar

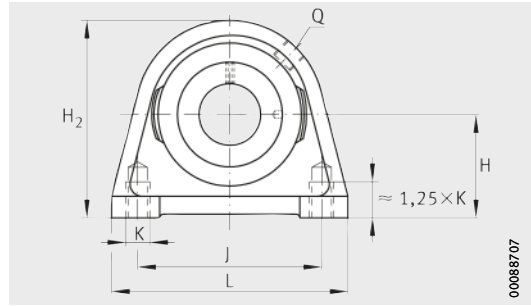

PSHE...XL, RSHE...XL, TSHE...XL



**Dimension table** - Dimensions in mm

Designation			Mass m ≈ kg	Dimensions						
Unit	Housing	Radial insert ball bearing		d	H	J	L	A	A <sub>1</sub>	H <sub>2</sub>
<b>PSHE12-XL</b>	SHE03	GRAE12-XL-NPP-B	0,44	<b>12</b>	30,2	47	63	30	18	57
<b>PSHE15-XL</b>	SHE03	GRAE15-XL-NPP-B	0,44	<b>15</b>	30,2	47	63	30	18	57
<b>PSHE17-XL</b>	SHE03	GRAE17-XL-NPP-B	0,44	<b>17</b>	30,2	47	63	30	18	57
<b>RSHE17-XL</b>	SHE03	GE17-XL-KRR-B	0,48	<b>17</b>	30,2	47	63	30	18	57
<b>PSHE20-XL-N</b>	SHE04	GRAE20-XL-NPP-B	0,46	<b>20</b>	33,3	50,8	65	32	19	64
<b>RSHE20-XL-N</b>	SHE04	GE20-XL-KRR-B	0,49	<b>20</b>	33,3	50,8	65	32	19	64
<b>TSHE20-XL-N</b>	SHE04	GE20-XL-KTT-B	0,49	<b>20</b>	33,3	50,8	65	32	19	64
<b>PSHE25-XL-N</b>	SHE05	GRAE25-XL-NPP-B	0,54	<b>25</b>	36,5	50,8	70	36	21	70
<b>RSHE25-XL-N</b>	SHE05	GE25-XL-KRR-B	0,6	<b>25</b>	36,5	50,8	70	36	21	70
<b>TSHE25-XL-N</b>	SHE05	GE25-XL-KTT-B	0,66	<b>25</b>	36,5	50,8	70	36	21	70
<b>PSHE30-XL-N</b>	SHE06	GRAE30-XL-NPP-B	0,94	<b>30</b>	42,9	76,2	98	40	25	82
<b>RSHE30-XL-N</b>	SHE06	GE30-XL-KRR-B	1,01	<b>30</b>	42,9	76,2	98	40	25	82
<b>TSHE30-XL-N</b>	SHE06	GE30-XL-KTT-B	1,01	<b>30</b>	42,9	76,2	98	40	25	82
<b>PSHE35-XL-N</b>	SHE07	GRAE35-XL-NPP-B	1,3	<b>35</b>	47,6	82,6	103	45	27	93
<b>RSHE35-XL-N</b>	SHE07	GE35-XL-KRR-B	1,38	<b>35</b>	47,6	82,6	103	45	27	93
<b>TSHE35-XL-N</b>	SHE07	GE35-XL-KTT-B	1,38	<b>35</b>	47,6	82,6	103	45	27	93
<b>PSHE40-XL-N</b>	SHE08	GRAE40-XL-NPP-B	1,84	<b>40</b>	49,2	88,9	116	48	30	99
<b>RSHE40-XL-N</b>	SHE08	GE40-XL-KRR-B	1,96	<b>40</b>	49,2	88,9	116	48	30	99
<b>TSHE40-XL-N</b>	SHE08	GE40-XL-KTT-B	1,66	<b>40</b>	49,2	88,9	116	48	30	99
<b>PSHE45-XL</b>	SHE09	GRAE45-XL-NPP-B	2,14	<b>45</b>	54	95,3	120	48	32	107
<b>RSHE45-XL</b>	SHE09	GE45-XL-KRR-B	2,26	<b>45</b>	54	95,3	120	48	32	107
<b>TSHE45-XL</b>	SHE09	GE45-XL-KTT-B	2,31	<b>45</b>	54	95,3	120	48	32	107
<b>PSHE50-XL-N</b>	SHE10	GRAE50-XL-NPP-B	2,79	<b>50</b>	57,2	101,6	135	54	34	115
<b>RSHE50-XL-N</b>	SHE10	GE50-XL-KRR-B	3,02	<b>50</b>	57,2	101,6	135	54	34	115
<b>TSHE50-XL-N</b>	SHE10	GE50-XL-KTT-B	2,47	<b>50</b>	57,2	101,6	135	54	34	115
<b>PSHE55-XL</b>	SHE11	GRAE55-XL-NPP-B	2,91	<b>55</b>	64	118	150	60	35	125
<b>RSHE55-XL</b>	SHE11	GE55-XL-KRR-B	3,52	<b>55</b>	64	118	150	60	35	125
<b>TSHE55-XL</b>	SHE11	GE55-XL-KTT-B	3,59	<b>55</b>	64	118	150	60	35	125
<b>PSHE60-XL-N</b>	SHE12	GRAE60-XL-NPP-B	4,1	<b>60</b>	69,9	118	150	60	42	140
<b>RSHE60-XL-N</b>	SHE12	GE60-XL-KRR-B	4,54	<b>60</b>	69,9	118	150	60	42	140
<b>TSHE60-XL-N</b>	SHE12	GE60-XL-KTT-B	4,22	<b>60</b>	69,9	118	150	60	42	140

1) To be ordered separately.  
 The caps are suitable for temperatures from -20 °C to +80 °C.



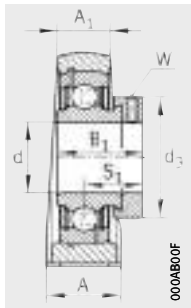

PSHE..XL

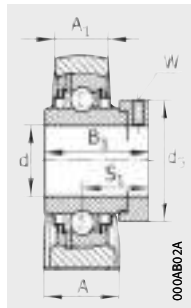

RSHE..XL

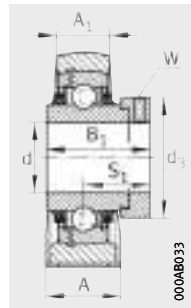

TSHE..XL

K	B <sub>1</sub>	S <sub>1</sub>	Q	d <sub>3</sub> max.	Width across flats W	Load carrying capacity Bearing			End cap <sup>1)</sup>
						Basic load ratings		Fatigue limit load C <sub>ur</sub> N	
						dyn. C <sub>r</sub> N	stat. C <sub>0r</sub> N		
M8	28,6	22,1	M6	28,41	3	10 100	4 750	241	–
M8	28,6	22,1	M6	28,4	3	10 100	4 750	241	–
M8	28,6	22,1	M6	28,4	3	10 100	4 750	241	–
M8	37,4	23,5	M6	28,4	3	10 100	4 750	241	–
M8	31	23,5	Rp <sup>1/8</sup>	33	3	13 600	6 600	335	KASK04
M8	43,7	26,6	Rp <sup>1/8</sup>	33	3	13 600	6 600	335	KASK04
M8	43,7	26,6	Rp <sup>1/8</sup>	33	3	13 600	6 600	335	KASK04
M10	31	23,5	M6	37,5	3	14 900	7 800	395	KASK05
M10	44,5	27	M6	37,5	3	14 900	7 800	395	KASK05
M10	44,5	27	M6	37,5	3	14 900	7 800	395	KASK05
M10	35,8	26,8	Rp <sup>1/8</sup>	44	4	20 700	11 300	570	KASK06
M10	48,5	30,2	Rp <sup>1/8</sup>	44	4	20 700	11 300	570	KASK06
M10	48,5	30,2	Rp <sup>1/8</sup>	44	4	20 700	11 300	570	KASK06
M10	39	29,5	Rp <sup>1/8</sup>	55	5	27 500	15 300	770	KASK07
M10	51,3	32,5	Rp <sup>1/8</sup>	55	5	27 500	15 300	770	KASK07
M10	51,3	32,5	Rp <sup>1/8</sup>	55	5	27 500	15 300	770	KASK07
M12	43,8	32,8	Rp <sup>1/8</sup>	58	5	34 500	19 800	1 010	KASK08
M12	56,5	35,1	Rp <sup>1/8</sup>	58	5	34 500	19 800	1 010	KASK08
M12	56,5	35,1	Rp <sup>1/8</sup>	58	5	34 500	19 800	1 010	KASK08
M12	43,8	32,8	M6	63	5	34 500	20 400	1 030	–
M12	56,5	35,1	M6	63	5	34 500	20 400	1 030	–
M12	56,5	35,1	M6	63	5	34 500	20 400	1 030	–
M16	43,8	32,8	M6	69	5	37 500	23 200	1 180	KASK10
M16	62,8	38,2	M6	69	5	37 500	23 200	1 180	KASK10
M16	62,8	38,2	M6	69	5	37 500	23 200	1 180	KASK10
M16	48,4	36,4	M6	76	5	46 000	29 000	1 480	–
M16	71,4	43,6	M6	76	5	46 000	29 000	1 480	–
M16	71,4	43,6	M6	76	5	46 000	29 000	1 480	–
M16	53,1	39,6	Rp <sup>1/8</sup>	84	5	56 000	36 000	1 820	KASK12
M16	77,9	46,9	Rp <sup>1/8</sup>	84	5	56 000	36 000	1 820	KASK12
M16	77,9	46,9	Rp <sup>1/8</sup>	84	5	56 000	36 000	1 820	KASK12



# Plummer block housing units

Flake graphite cast iron housing  
 With short base  
 With grub screws

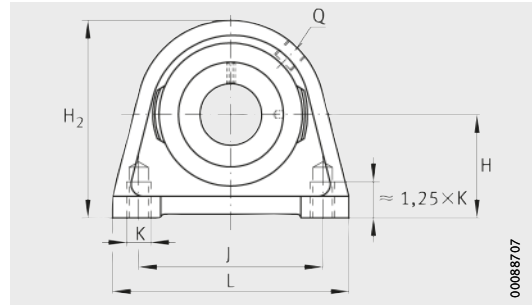

PSHEY..-XL, RSHEY..-XL



**Dimension table** - Dimensions in mm

Designation			Mass m ≈ kg	Dimensions					
Unit	Housing	Radial insert ball bearing		d	H	J	L	A	A <sub>1</sub>
<b>PSHEY12-XL</b>	SHE03	GAY12-XL-NPP-B	0,42	<b>12</b>	30,2	47	63	30	18
<b>PSHEY15-XL</b>	SHE03	GAY15-XL-NPP-B	0,41	<b>15</b>	30,2	47	63	30	18
<b>RSHEY15-XL</b>	SHE03	GYE15-XL-KRR-B	0,42	<b>15</b>	30,2	47	63	30	18
<b>PSHEY17-XL</b>	SHE03	GAY17-XL-NPP-B	0,4	<b>17</b>	30,2	47	63	30	18
<b>RSHEY17-XL</b>	SHE03	GAY17-XL-KRR-B	0,41	<b>17</b>	30,2	47	63	30	18
<b>PSHEY20-XL-N</b>	SHE04	GAY20-XL-NPP-B	0,42	<b>20</b>	33,3	50,8	65	32	19
<b>RSHEY20-XL-N</b>	SHE04	GYE20-XL-KRR-B	0,43	<b>20</b>	33,3	50,8	65	32	19
<b>PSHEY25-XL-N</b>	SHE05	GAY25-XL-NPP-B	0,57	<b>25</b>	36,5	50,8	70	36	21
<b>RSHEY25-XL-N</b>	SHE05	GYE25-XL-KRR-B	0,54	<b>25</b>	36,5	50,8	70	36	21
<b>PSHEY30-XL-N</b>	SHE06	GAY30-XL-NPP-B	0,88	<b>30</b>	42,9	76,2	98	40	25
<b>RSHEY30-XL-N</b>	SHE06	GYE30-XL-KRR-B	0,94	<b>30</b>	42,9	76,2	98	40	25
<b>PSHEY35-XL-N</b>	SHE07	GAY35-XL-NPP-B	1,19	<b>35</b>	47,6	82,6	103	45	27
<b>RSHEY35-XL-N</b>	SHE07	GYE35-XL-KRR-B	1,25	<b>35</b>	47,6	82,6	103	45	27
<b>PSHEY40-XL-N</b>	SHE08	GAY40-XL-NPP-B	1,73	<b>40</b>	49,2	88,9	116	48	30
<b>RSHEY40-XL-N</b>	SHE08	GYE40-XL-KRR-B	1,53	<b>40</b>	49,2	88,9	116	48	30
<b>PSHEY45-XL</b>	SHE09	GAY45-XL-NPP-B	1,91	<b>45</b>	54	95,3	120	48	32
<b>RSHEY45-XL</b>	SHE09	GYE45-XL-KRR-B	2,15	<b>45</b>	54	95,3	120	48	32
<b>PSHEY50-XL-N</b>	SHE10	GAY50-XL-NPP-B	2,64	<b>50</b>	57,2	101,6	135	54	34
<b>RSHEY50-XL-N</b>	SHE10	GYE50-XL-KRR-B	2,82	<b>50</b>	57,2	101,6	135	54	34
<b>RSHEY55-XL</b>	SHE11	GYE55-XL-KRR-B	3,29	<b>55</b>	64	118	150	60	35
<b>PSHEY60-XL-N</b>	SHE12	GAY60-XL-NPP-B	3,6	<b>60</b>	69,9	118	150	60	42
<b>RSHEY60-XL-N</b>	SHE12	GYE60-XL-KRR-B	3,9	<b>60</b>	69,9	118	150	60	42

<sup>1)</sup> To be ordered separately.  
 The caps are suitable for temperatures from -20 °C to +80 °C.

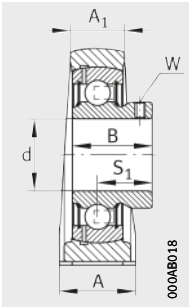

PSHEY..-XL

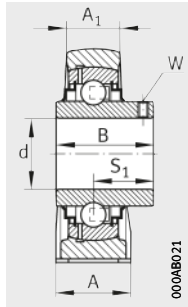

RSHEY..-XL

					Width across flats W	Load carrying capacity Bearing			End cap <sup>1)</sup>
						Basic load ratings		Fatigue limit load C <sub>ur</sub> N	
H <sub>2</sub>	K	B	S <sub>1</sub>	Q		dyn. C <sub>r</sub> N	stat. C <sub>0r</sub> N		
57	M8	22	16	M6	2,5	10 100	4 750	241	–
57	M8	22	16	M6	2,5	10 100	4 750	241	–
57	M8	27,4	15,9	M6	2,5	10 100	4 750	241	–
57	M8	22	16	M6	2,5	10 100	4 750	241	–
57	M8	27,4	15,9	M6	2,5	10 100	4 750	241	–
64	M8	25	18	Rp <sup>1/8</sup>	2,5	13 600	6 600	335	KASK04
64	M8	31	18,3	Rp <sup>1/8</sup>	2,5	13 600	6 600	335	KASK04
70	M10	27	19,5	M6	2,5	14 900	7 800	395	KASK05
70	M10	34,1	19,8	M6	2,5	14 900	7 800	395	KASK05
82	M10	30	21	Rp <sup>1/8</sup>	3	20 700	11 300	570	KASK06
82	M10	38,1	22,2	Rp <sup>1/8</sup>	3	20 700	11 300	570	KASK06
93	M10	35	25,5	Rp <sup>1/8</sup>	3	27 500	15 300	770	KASK07
93	M10	42,9	25,4	Rp <sup>1/8</sup>	3	27 500	15 300	770	KASK07
99	M12	39,5	29	Rp <sup>1/8</sup>	4	34 500	19 800	1 010	KASK08
99	M12	49,2	30,2	Rp <sup>1/8</sup>	4	34 500	19 800	1 010	KASK08
107	M12	41,5	30,5	M6	4	34 500	20 400	1 030	–
107	M12	49,2	30,2	M6	4	34 500	20 400	1 030	–
115	M16	43	32	M6	4	37 500	23 200	1 180	KASK10
115	M16	51,6	32,6	M6	4	37 500	23 200	1 180	KASK10
125	M16	55,6	33,4	M6	4	46 000	29 000	1 480	–
140	M16	47	34	Rp <sup>1/8</sup>	5	56 000	36 000	1 820	KASK12
140	M16	65,1	39,7	Rp <sup>1/8</sup>	5	56 000	36 000	1 820	KASK12



## Two-bolt flanged housing units

Flake graphite cast iron  
housing  
Oval, wide version  
With eccentric locking collar

**X-life**

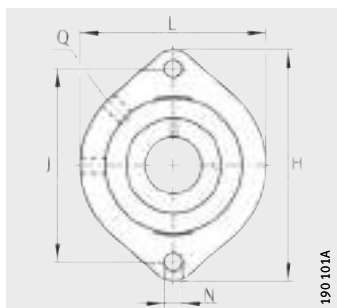

GLCTE..-XL

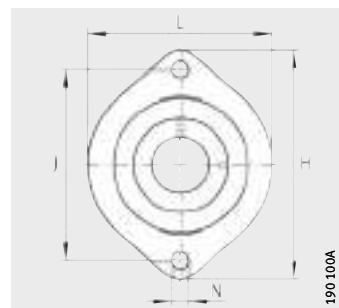

FLCTE..-XL

**Dimension table** - Dimensions in mm

Designation			Mass m ≈ kg	Dimensions				
Unit	Housing	Radial insert ball bearing		d	H	J	L	A <sub>1</sub>
<b>FLCTE12-XL</b>	LCTE03	RAE12-XL-NPP-B	0,3	<b>12</b>	81	63,5	58,7	15
<b>GLCTE12-XL</b> <sup>1)</sup>	GLCTE03	GRAE12-XL-NPP-B	0,3	<b>12</b>	81	63,5	58,7	15
<b>FLCTE15-XL</b>	LCTE03	RAE15-XL-NPP-B	0,3	<b>15</b>	81	63,5	58,7	15
<b>GLCTE15-XL</b> <sup>1)</sup>	GLCTE03	GRAE15-XL-NPP-B	0,3	<b>15</b>	81	63,5	58,7	15
<b>FLCTE17-XL</b>	LCTE03	RAE17-XL-NPP-B	0,3	<b>17</b>	81	63,5	58,7	15
<b>GLCTE17-XL</b> <sup>1)</sup>	GLCTE03	GRAE17-XL-NPP-B	0,3	<b>17</b>	81	63,5	58,7	15
<b>FLCTE20-XL</b>	LCTE04	RAE20-XL-NPP-B	0,39	<b>20</b>	90,5	71,4	66,5	17
<b>GLCTE20-XL</b> <sup>2)</sup>	GLCTE04	GRAE20-XL-NPP-B	0,39	<b>20</b>	90,5	71,4	66,5	17
<b>FLCTE25-XL</b>	LCTE05	RAE25-XL-NPP-B	0,47	<b>25</b>	97	76,2	71	17,5
<b>GLCTE25-XL</b> <sup>2)</sup>	GLCTE05	GRAE25-XL-NPP-B	0,47	<b>25</b>	97	76,2	71	17,5
<b>FLCTE30-XL</b>	LCTE06	RAE30-XL-NPP-B	0,76	<b>30</b>	112,5	90,5	84	20,5
<b>GLCTE30-XL</b> <sup>2)</sup>	GLCTE06	GRAE30-XL-NPP-B	0,76	<b>30</b>	112,5	90,5	84	20,5
<b>FLCTE35-XL</b>	LCTE07	RAE35-XL-NPP-B	1,02	<b>35</b>	126	100	94	22
<b>GLCTE35-XL</b> <sup>1)</sup>	GLCTE07	GRAE35-XL-NPP-B	1,01	<b>35</b>	126	100	94	22
<b>FLCTE40-XL</b>	LCTE08	RAE40-XL-NPP-B	1,32	<b>40</b>	150	119	100	24
<b>GLCTE40-XL</b> <sup>1)</sup>	GLCTE08	GRAE40-XL-NPP-B	1,3	<b>40</b>	150	119	100	24

<sup>1)</sup> Lubrication hole 90°.

<sup>2)</sup> Lubrication hole 45°.

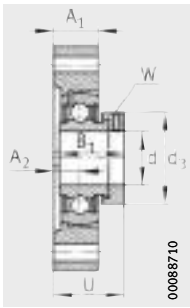

GLCTE..-XL

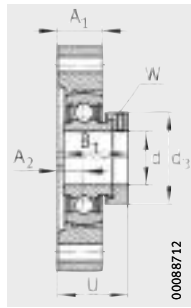

FLCTE..-XL

						Width across flats W	Load carrying capacity Bearing		
							Basic load ratings		Fatigue limit load C <sub>ur</sub> N
A <sub>2</sub>	N	B <sub>1</sub>	U	Q	d <sub>3</sub> max.		dyn. C <sub>r</sub> N	stat. C <sub>0r</sub> N	
8,4	6,6	28,6	30,5	–	28,4	3	10 100	4 750	241
8,4	6,6	28,6	30,5	M6 <sup>1)</sup>	28,4	3	10 100	4 750	241
8,4	6,6	28,6	30,5	–	28,4	3	10 100	4 750	241
8,4	6,6	28,6	30,5	M6 <sup>1)</sup>	28,4	3	10 100	4 750	241
8,4	6,6	28,6	30,5	–	28,4	3	10 100	4 750	241
8,4	6,6	28,6	30,5	M6 <sup>1)</sup>	28,4	3	10 100	4 750	241
9,5	9	31	33	–	33	3	13 600	6 600	335
9,5	9	31	33	M6 <sup>2)</sup>	33	3	13 600	6 600	335
9,9	9	31	33,4	–	37,5	3	14 900	7 800	395
9,9	9	31	33,4	M6 <sup>2)</sup>	37,5	3	14 900	7 800	395
11,4	11,5	35,8	38,1	–	44	4	20 700	11 300	570
11,4	11,5	35,8	38,1	M6 <sup>2)</sup>	44	4	20 700	11 300	570
12,4	11,5	39	42	–	55	5	27 500	15 300	770
12,4	11,5	39	42	M6 <sup>1)</sup>	55	5	27 500	15 300	770
13,5	14	43,8	46,3	–	58	5	34 500	19 800	1 010
13,5	14	43,8	46,3	M6 <sup>1)</sup>	58	5	34 500	19 800	1 010



# Two-bolt flanged housing units

Flake graphite cast iron housing  
 Oval, wide version  
 With grub screws

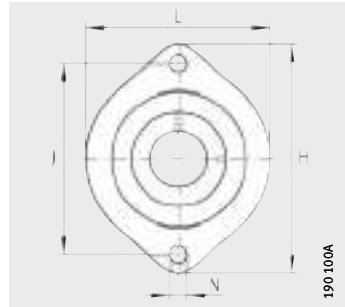

FLCTEY..-XL



**Dimension table** - Dimensions in mm

Designation			Mass m ≈ kg	Dimensions			
Unit	Housing	Radial insert ball bearing		d	H	J	L
<b>FLCTEY12-XL</b>	LCTE03	AY12-XL-NPP-B	0,28	<b>12</b>	81	63,5	58,7
<b>FLCTEY15-XL</b>	LCTE03	AY15-XL-NPP-B	0,27	<b>15</b>	81	63,5	58,7
<b>FLCTEY17-XL</b>	LCTE03	AY17-XL-NPP-B	0,26	<b>17</b>	81	63,5	58,7
<b>FLCTEY20-XL</b>	LCTE04	AY20-XL-NPP-B	0,36	<b>20</b>	90,5	71,4	66,5
<b>FLCTEY25-XL</b>	LCTE05	AY25-XL-NPP-B	0,44	<b>25</b>	97	76,2	71
<b>FLCTEY30-XL</b>	LCTE06	AY30-XL-NPP-B	0,7	<b>30</b>	112,5	90,5	84
<b>FLCTEY35-XL</b>	LCTE07	GAY35-XL-NPP-B	0,93	<b>35</b>	126	100	94
<b>FLCTEY40-XL</b>	LCTE08	GAY40-XL-NPP-B	1,18	<b>40</b>	150	119	100

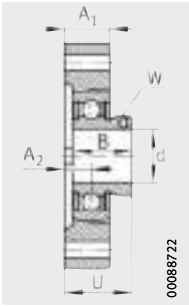

FLCTEY..-XL

					Width across flats W	Load carrying capacity Bearing		
						Basic load ratings		Fatigue limit load C <sub>ur</sub> N
A <sub>1</sub>	A <sub>2</sub>	N	B	U		dyn. C <sub>r</sub> N	stat. C <sub>0r</sub> N	
15	8,4	6,6	22	24,4	2,5	10 100	4 750	241
15	8,4	6,6	22	24,4	2,5	10 100	4 750	241
15	8,4	6,6	22	24,4	2,5	10 100	4 750	241
17	9,5	9	25	27	2,5	13 600	6 600	335
17,5	9,9	9	27	29,4	2,5	14 900	7 800	395
20,5	11,4	11,5	30	32,4	3	20 700	11 300	570
22	12,4	11,5	35	37,9	3	27 500	15 300	770
24	13,5	14	39,5	42,5	4	34 500	19 800	1 010



# Two-bolt flanged housing units

Flake graphite cast iron housing  
Oval, narrow version  
Eccentric locking collar

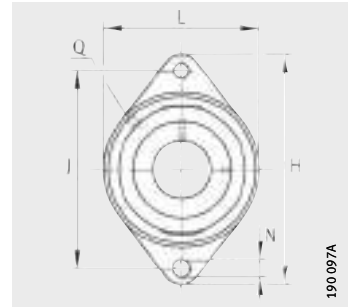

PCFT..-XL, PCJT..-XL(-N),  
RCJT..-XL(-N,-FA164), TCJT..-XL-N,  
LCJT..-XL-N



**Dimension table** - Dimensions in mm

Designation			Mass m ≈ kg	Dimensions					
Unit	Housing	Radial insert ball bearing		d	H	J	L	A	A <sub>1</sub>
PCFT12-XL	CFT03	GRAE12-XL-NPP-B	0,39	12	99	76,5	57	18	9,5
PCJT12-XL	CJT03	GRAE12-XL-NPP-B	0,37	12	99	76,5	57	25	9,5
PCFT15-XL	CFT03	GRAE15-XL-NPP-B	0,39	15	99	76,5	57	18	9,5
PCJT15-XL	CJT03	GRAE15-XL-NPP-B	0,37	15	99	76,5	57	25	9,5
PCFT17-XL	CFT03	GRAE17-XL-NPP-B	0,39	17	99	76,5	57	18	9,5
PCJT17-XL	CJT03	GRAE17-XL-NPP-B	0,37	17	99	76,5	57	25	9,5
RCJT17-XL	CJT03	GE17-XL-KRR-B	0,41	17	99	76,5	57	25	9,5
PCFT20-XL	CFT04	GRAE20-XL-NPP-B	0,4	20	112	90	61	17,5	10
PCJT20-XL-N	CJT04	GRAE20-XL-NPP-B	0,48	20	112	90	61	28	10
LCJT20-XL-N <sup>2)</sup>	CJT04	GE20-XL-KLL-B	0,52	20	112	90	61	28	10
RCJT20-XL-N	CJT04	GE20-XL-KRR-B	0,52	20	112	90	61	28	10
TCJT20-XL-N	CJT04	GE20-XL-KTT-B	0,48	20	112	90	61	28	10
PCFT25-XL	CFT05	GRAE25-XL-NPP-B	0,52	25	124	99	70	20	11
PCJT25-XL-N	CJT05	GRAE25-XL-NPP-B	0,58	25	124	99	70	26,5	11
LCJT25-XL-N <sup>2)</sup>	CJT05	GE25-XL-KLL-B	0,62	25	124	99	70	26,5	11
RCJT25-XL-N	CJT05	GE25-XL-KRR-B	0,62	25	124	99	70	26,5	11
TCJT25-XL-N	CJT05	GE25-XL-KTT-B	0,64	25	124	99	70	26,5	11
PCFT30-XL	CFT06	GRAE30-XL-NPP-B	0,77	30	142	116,5	80	22,3	12
PCJT30-XL-N	CJT06	GRAE30-XL-NPP-B	0,81	30	142	116,5	80	29	12
LCJT30-XL-N <sup>2)</sup>	CJT06	GE30-XL-KLL-B	0,9	30	142	116,5	80	29	12
RCJT30-XL-FA164 <sup>2)</sup>	CJT06	GE30-XL-KRR-B-FA164	0,88	30	142	116,5	80	29	12
RCJT30-XL-N	CJT06	GE30-XL-KRR-B	0,88	30	142	116,5	80	29	12
TCJT30-XL-N	CJT06	GE30-XL-KTT-B	0,9	30	142	116,5	80	29	12
PCFT35-XL	CFT07	GRAE35-XL-NPP-B	1,04	35	155	130	92	25	12,5
PCJT35-XL-N	CJT07	GRAE35-XL-NPP-B	1,11	35	155	130	92	30,5	12,5
LCJT35-XL-N <sup>2)</sup>	CJT07	GE35-XL-KLL-B	1,19	35	155	130	92	30,5	12,5
RCJT35-XL-FA164 <sup>2)</sup>	CJT07	GE35-XL-KRR-B-FA164	1,2	35	155	130	92	30,5	12,5
RCJT35-XL-N	CJT07	GE35-XL-KRR-B	1,19	35	155	130	92	30,5	12,5
TCJT35-XL-N	CJT07	GE35-XL-KTT-B	1,17	35	155	130	92	30,5	12,5

1) To be ordered separately.  
The caps are suitable for temperatures from -20 °C to +80 °C.  
2) With fitted lubrication nipple.



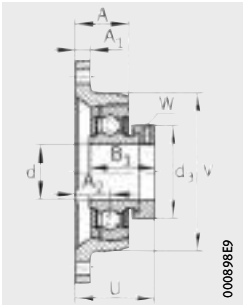

PCFT..XL, PCJT..XL(-N)

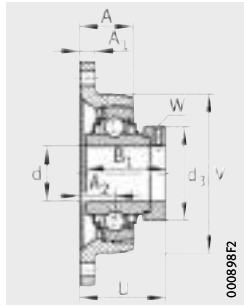

RCJT..XL(-N, -FA164)

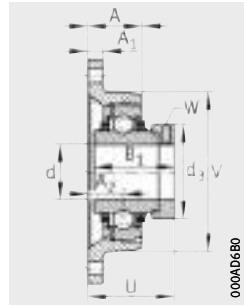

TCJT..XL-N

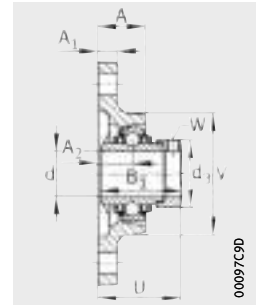

LCJT..XL-N

A <sub>2</sub>	N	B <sub>1</sub>	U	V	Q	d <sub>3</sub> max.	W	Load carrying capacity Bearing			End cap <sup>1)</sup>
								Basic load ratings		Fatigue limit load C <sub>ur</sub> N	
								dyn. C <sub>r</sub> N	stat. C <sub>0r</sub> N		
10	11,5	28,6	32,1	57	M6	28,4	3	10 100	4 750	241	-
17	11,5	28,6	39,1	57	M6	28,4	3	10 100	4 750	241	-
10	11,5	28,6	32,1	57	M6	28,4	3	10 100	4 750	241	-
17	11,5	28,6	39,1	57	M6	28,4	3	10 100	4 750	241	-
10	11,5	28,6	32,1	57	M6	28,4	3	10 100	4 750	241	-
17	11,5	28,6	39,1	57	M6	28,4	3	10 100	4 750	241	-
17	11,5	37,4	40,4	57	M6	28,4	3	10 100	4 750	241	-
10,5	11,5	31	34	61	M6	33	3	13 600	6 600	335	-
19	11,5	31	42,5	61	M6	33	3	13 600	6 600	335	KASK04
19	11,5	43,7	45,6	61	M6	33	3	13 600	6 600	335	KASK04
19	11,5	43,7	45,6	61	M6	33	3	13 600	6 600	335	KASK04
19	11,5	43,7	45,6	61	M6	33	3	13 600	6 600	335	KASK04
12,5	11,5	31	36	70	M6	37,5	3	14 900	7 800	395	-
19	11,5	31	42,5	70	M6	37,5	3	14 900	7 800	395	KASK05
19	11,5	44,5	46	70	M6	37,5	3	14 900	7 800	395	KASK05
19	11,5	44,5	46	70	M6	37,5	3	14 900	7 800	395	KASK05
19	11,5	44,5	46	70	M6	37,5	3	14 900	7 800	395	KASK05
13,3	11,5	35,8	40	80	M6	44	4	20 700	11 300	570	-
20	11,5	35,8	46,8	80	M6	44	4	20 700	11 300	570	KASK06
20	11,5	48,5	50,2	80	M6	44	4	20 700	11 300	570	KASK06
20	11,5	48,5	50,2	80	M6	44	4	20 700	11 300	570	-
20	11,5	48,5	50,2	80	M6	44	4	20 700	11 300	570	KASK06
20	11,5	48,5	50,2	80	M6	44	4	20 700	11 300	570	KASK06
15,5	14	39	44,9	92	M6	55	5	27 500	15 300	770	-
21	14	39	50,5	92	M6	55	5	27 500	15 300	770	KASK07
21	14	51,3	53,5	92	M6	55	5	27 500	15 300	770	KASK07
21	14	51,3	53,5	92	M6	55	5	27 500	15 300	770	-
21	14	51,3	53,5	92	M6	55	5	27 500	15 300	770	KASK07
21	14	51,3	53,5	92	M6	55	5	27 500	15 300	770	KASK07



# Two-bolt flanged housing units

Flake graphite cast iron housing  
 Oval, narrow version  
 Eccentric locking collar

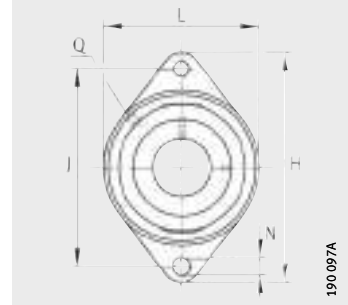

PCFT..-XL, PCJT..-XL(-N),  
 RCJT..-XL(-N,-FA164),  
 TCJT..-XL(-N), LCJT..-XL(-N)



**Dimension table** (continued) · Dimensions in mm

Designation			Mass	Dimensions						
Unit	Housing	Radial insert ball bearing		m	d	H	J	L	A	A <sub>1</sub>
			≈ kg							
<b>PCFT40-XL</b>	CFT08	GRAE40-XL-NPP-B	1,42	<b>40</b>	172	143,5	105	28,8	13	
<b>PCJT40-XL-N</b>	CJT08	GRAE40-XL-NPP-B	1,54	<b>40</b>	172	143,5	105	34,5	13	
<b>LCJT40-XL-N<sup>2)</sup></b>	CJT08	GE40-XL-KLL-B	1,66	<b>40</b>	172	143,5	105	34,5	13	
<b>RCJT40-XL-FA164<sup>2)</sup></b>	CJT08	GE40-XL-KRR-B-FA164	1,66	<b>40</b>	172	143,5	105	34,5	13	
<b>TCJT40-XL-N</b>	CJT08	GE40-XL-KTT-B	1,7	<b>40</b>	172	143,5	105	34,5	13	
<b>PCFT45-XL</b>	CFT09	GRAE45-XL-NPP-B	1,59	<b>45</b>	180	148,5	111	30,2	13	
<b>PCJT45-XL</b>	CJT09	GRAE45-XL-NPP-B	1,69	<b>45</b>	180	148,5	111	35	13	
<b>LCJT45-XL<sup>2)</sup></b>	CJT09	GE45-XL-KLL-B	1,81	<b>45</b>	180	148,5	111	35	13	
<b>RCJT45-XL</b>	CJT09	GE45-XL-KRR-B	1,81	<b>45</b>	180	148,5	111	35	13	
<b>TCJT45-XL</b>	CJT09	GE45-XL-KTT-B	1,92	<b>45</b>	180	148,5	111	35	13	
<b>PCFT50-XL</b>	CFT10	GRAE50-XL-NPP-B	1,82	<b>50</b>	190	157	116	30,2	13	
<b>PCJT50-XL-N</b>	CJT10	GRAE50-XL-NPP-B	1,97	<b>50</b>	190	157	116	39	13	
<b>LCJT50-XL-N<sup>2)</sup></b>	CJT10	GE50-XL-KLL-B	2,21	<b>50</b>	190	157	116	39	13	
<b>RCJT50-XL-FA164<sup>2)</sup></b>	CJT10	GE50-XL-KRR-B-FA164	2,2	<b>50</b>	190	157	116	39	13	
<b>TCJT50-XL-N</b>	CJT10	GE50-XL-KTT-B	2,19	<b>50</b>	190	157	116	39	13	
<b>PCJT55-XL</b>	CJT11	GRAE55-XL-NPP-B	2,31	<b>55</b>	222	184	134	43,5	15	
<b>RCJT55-XL</b>	CJT11	GE55-XL-KRR-B	2,92	<b>55</b>	222	184	134	43,5	15	
<b>TCJT55-XL</b>	CJT11	GE55-XL-KTT-B	3,15	<b>55</b>	222	184	134	43,5	15	
<b>PCJT60-XL-N</b>	CJT12	GRAE60-XL-NPP-B	3,25	<b>60</b>	238	202	138	46	16	
<b>RCJT60-XL-N</b>	CJT12	GE60-XL-KRR-B	3,69	<b>60</b>	238	202	138	46	16	
<b>RCJT65-214-XL<sup>2)</sup></b>	CJT13/14	GE65-214-XL-KRR-B	6,41	<b>65</b>	258	216	160	57	18	
<b>TCJT65-214-XL<sup>2)</sup></b>	CJT13/14	GE65-214-XL-KTT-B	6,41	<b>65</b>	258	216	160	57	18	
<b>RCJT70-XL</b>	CJT13/14	GE70-XL-KRR-B	6,15	<b>70</b>	258	216	160	57	18	
<b>RCJT75-XL</b>	CJT15	GE75-XL-KRR-B	6	<b>75</b>	258	216	160	57	18	

<sup>1)</sup> To be ordered separately.  
 The caps are suitable for temperatures from -20 °C to +80 °C.

<sup>2)</sup> With fitted lubrication nipple.

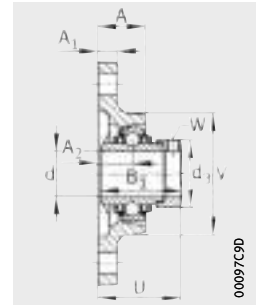
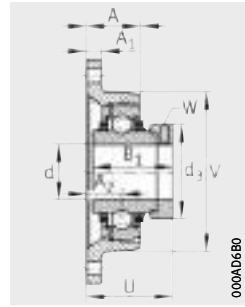
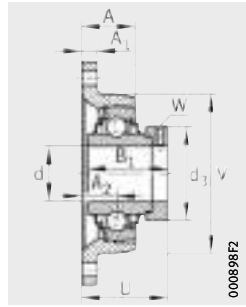
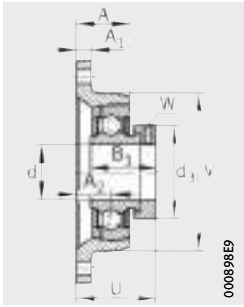

PCFT..XL, PCJT..XL(-N)

RCJT..XL(-N, -FA164)

TCJT..XL(-N)

LCJT..XL(-N)

A <sub>2</sub>	N	B <sub>1</sub>	U	V	Q	d <sub>3</sub> max.	W	Load carrying capacity Bearing			End cap <sup>1)</sup>
								Basic load ratings		Fatigue limit load C <sub>ur</sub> N	
								dyn. C <sub>r</sub> N	stat. C <sub>0r</sub> N		
18,3	14	43,8	51	105	M6	58	5	34 500	19 800	1 010	–
24	14	43,8	56,7	105	Rp <sup>1/8</sup>	58	5	34 500	19 800	1 010	KASK08
24	14	56,5	59,1	105	Rp <sup>1/8</sup>	58	5	34 500	19 800	1 010	KASK08
24	14	56,5	59,1	105	Rp <sup>1/8</sup>	58	5	34 500	19 800	1 010	–
24	14	56,5	59,1	105	Rp <sup>1/8</sup>	58	5	34 500	19 800	1 010	KASK08
24	14	56,5	59,1	105	Rp <sup>1/8</sup>	58	5	34 500	19 800	1 010	KASK08
19,2	14	43,8	51,9	111	M6	63	5	34 500	20 400	1 030	–
24	14	43,8	56,7	111	Rp <sup>1/8</sup>	63	5	34 500	20 400	1 030	–
24	14	56,5	59,1	111	Rp <sup>1/8</sup>	63	5	34 500	20 400	1 030	–
24	14	56,5	59,1	111	Rp <sup>1/8</sup>	63	5	34 500	20 400	1 030	–
24	14	56,5	59,1	111	Rp <sup>1/8</sup>	63	5	34 500	20 400	1 030	–
19,2	14	43,8	51,9	116	Rp <sup>1/8</sup>	69	5	37 500	23 200	1 180	–
28	18	43,8	60,7	116	Rp <sup>1/8</sup>	69	5	37 500	23 200	1 180	KASK10
28	18	62,8	66,2	116	Rp <sup>1/8</sup>	69	5	37 500	23 200	1 180	KASK10
28	18	62,8	66,2	116	Rp <sup>1/8</sup>	69	5	37 500	23 200	1 180	–
28	18	62,8	66,2	116	Rp <sup>1/8</sup>	69	5	37 500	23 200	1 180	KASK10
28	18	62,8	66,2	116	Rp <sup>1/8</sup>	69	5	37 500	23 200	1 180	KASK10
31	18	48,4	67,4	134	M6	76	5	46 000	29 000	1 480	–
31	18	71,4	74,6	134	M6	76	5	46 000	29 000	1 480	–
31	18	71,4	74,6	134	M6	76	5	46 000	29 000	1 480	–
34	18	53,1	73,6	138	Rp <sup>1/8</sup>	84	5	56 000	36 000	1 820	KASK12
34	18	77,9	80,8	138	Rp <sup>1/8</sup>	84	5	56 000	36 000	1 820	KASK12
38	21	66	82,6	160	M6	96	6	66 000	44 000	2 230	–
38	21	66	82,6	160	M6	96	6	66 000	44 000	2 230	–
38	21	66	82,6	160	M6	96	6	66 000	44 000	2 230	–
38	21	67	83,6	160	M6	100	6	66 000	44 500	2 240	–



# Two-bolt flanged housing units

Flake graphite cast iron housing  
 Oval, narrow version  
 Grub screws in inner ring

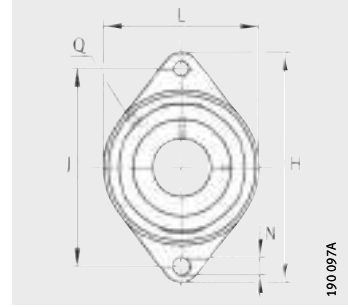

PCJTY...-XL(-N), RCJTY...-XL(-N)



**Dimension table** - Dimensions in mm

Designation			Mass m ≈ kg	Dimensions					
Unit	Housing	Radial insert ball bearing		d	H	J	L	A	A <sub>1</sub>
<b>PCJTY12-XL</b>	CJT03	GAY12-XL-NPP-B	0,35	<b>12</b>	99	76,5	57	25	9,5
<b>RCJTY12-XL</b>	CJT03	GYE12-XL-KRR-B	0,36	<b>12</b>	99	76,5	57	25	9,5
<b>PCJTY15-XL</b>	CJT03	GAY15-XL-NPP-B	0,34	<b>15</b>	99	76,5	57	25	9,5
<b>RCJTY15-XL</b>	CJT03	GYE15-XL-KRR-B	0,35	<b>15</b>	99	76,5	57	25	9,5
<b>RCJTY16-XL</b>	CJT03	GYE16-XL-KRR-B	0,34	<b>16</b>	99	76,5	57	25	9,5
<b>PCJTY17-XL</b>	CJT03	GAY17-XL-NPP-B	0,33	<b>17</b>	99	76,5	57	25	9,5
<b>RCJTY17-XL</b>	CJT03	GYE17-XL-KRR-B	0,34	<b>17</b>	99	76,5	57	25	9,5
<b>PCJTY20-XL-N</b>	CJT04	GAY20-XL-NPP-B	0,41	<b>20</b>	112	90	61	28	10
<b>RCJTY20-XL-N</b>	CJT04	GYE20-XL-KRR-B	0,42	<b>20</b>	112	90	61	28	10
<b>PCJTY25-XL-N</b>	CJT05	GAY25-XL-NPP-B	0,48	<b>25</b>	124	99	70	26,5	11
<b>RCJTY25-XL-N</b>	CJT05	GYE25-XL-KRR-B	0,57	<b>25</b>	124	99	70	26,5	11
<b>PCJTY30-XL-N</b>	CJT06	GAY30-XL-NPP-B	0,77	<b>30</b>	142	116,5	80	29	12
<b>RCJTY30-XL-N</b>	CJT06	GYE30-XL-KRR-B	0,88	<b>30</b>	142	116,5	80	29	12
<b>PCJTY35-XL-N</b>	CJT07	GAY35-XL-NPP-B	1,05	<b>35</b>	155	130	92	30,5	12,5
<b>RCJTY35-XL-N</b>	CJT07	GYE35-XL-KRR-B	1,13	<b>35</b>	155	130	92	30,5	12,5
<b>PCJTY40-XL-N</b>	CJT08	GAY40-XL-NPP-B	1,48	<b>40</b>	172	143,5	105	34,5	13
<b>RCJTY40-XL-N</b>	CJT08	GYE40-XL-KRR-B	1,57	<b>40</b>	172	143,5	105	34,5	13
<b>PCJTY45-XL</b>	CJT09	GAY45-XL-NPP-B	1,69	<b>45</b>	180	148,5	111	35	13
<b>RCJTY45-XL</b>	CJT09	GYE45-XL-KRR-B	1,7	<b>45</b>	180	148,5	111	35	13
<b>PCJTY50-XL-N</b>	CJT10	GAY50-XL-NPP-B	1,82	<b>50</b>	190	157	116	39	13
<b>RCJTY50-XL-N</b>	CJT10	GYE50-XL-KRR-B	2	<b>50</b>	190	157	116	39	13
<b>RCJTY55-XL</b>	CJT11	GYE55-XL-KRR-B	2,86	<b>55</b>	222	184	134	43,5	15
<b>PCJTY60-XL-N</b>	CJT12	GAY60-XL-NPP-B	2,92	<b>60</b>	238	202	138	46	16
<b>RCJTY60-XL-N</b>	CJT12	GYE60-XL-KRR-B	3,46	<b>60</b>	238	202	138	46	16
<b>RCJTY65-214-XL<sup>2)</sup></b>	CJT13/14	GYE65-214-XL-KRR-B	5,95	<b>65</b>	258	216	160	57	18
<b>RCJTY70-XL</b>	CJT13/14	GYE70-XL-KRR-B	5,65	<b>70</b>	258	216	160	57	18
<b>RCJTY75-XL</b>	CJT15	GYE75-XL-KRR-B	5,53	<b>75</b>	258	216	160	57	18

1) To be ordered separately.  
 The caps are suitable for temperatures from -20 °C to +80 °C.  
 2) Alternative ball set 6214.

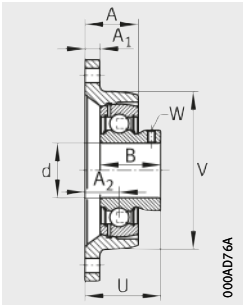

PCJTY..-XL(-N)

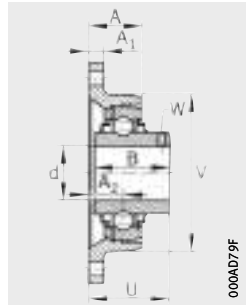

RCJTY..-XL(-N)

						Width across flats W	Load carrying capacity Bearing			End cap <sup>1)</sup>
							Basic load ratings		Fatigue limit load C <sub>ur</sub> N	
A <sub>2</sub>	N	B	U	V	Q		dyn. C <sub>r</sub> N	stat. C <sub>0r</sub> N		
17	11,5	22	33	57	M6	2,5	10 100	4 750	241	–
17	11,5	27,4	32,9	57	M6	2,5	10 100	4 750	241	–
17	11,5	22	33	57	M6	2,5	10 100	4 750	241	–
17	11,5	27,4	32,9	57	M6	2,5	10 100	4 750	241	–
17	11,5	27,4	32,9	57	M6	2,5	10 100	4 750	241	–
17	11,5	22	33	57	M6	2,5	10 100	4 750	241	–
17	11,5	27,4	32,9	57	M6	2,5	10 100	4 750	241	–
19	11,5	25	37	61	M6	2,5	13 600	6 600	335	KASK04
19	11,5	31	37,3	61	M6	2,5	13 600	6 600	335	KASK04
19	11,5	27	38,5	70	M6	2,5	14 900	7 800	395	KASK05
19	11,5	34,1	38,8	70	M6	2,5	14 900	7 800	395	KASK05
20	11,5	30	41	80	M6	3	20 700	11 300	570	KASK06
20	11,5	38,1	42,2	80	M6	3	20 700	11 300	570	KASK06
21	14	35	46,45	92	M6	3	27 500	15 300	770	KASK07
21	14	42,9	46,4	92	M6	3	27 500	15 300	770	KASK07
24	14	39,5	52,95	105	Rp <sup>1/8</sup>	4	34 500	19 800	1 010	KASK08
24	14	49,2	54,2	105	Rp <sup>1/8</sup>	4	34 500	19 800	1 010	KASK08
24	14	41,5	54,5	111	Rp <sup>1/8</sup>	4	34 500	20 400	1 030	–
24	14	49,2	54,2	111	Rp <sup>1/8</sup>	4	34 500	20 400	1 030	–
28	18	43	60	116	Rp <sup>1/8</sup>	4	37 500	23 200	1 180	KASK10
28	18	51,6	60,6	116	Rp <sup>1/8</sup>	4	37 500	23 200	1 180	KASK10
31	18	55,6	64,4	134	M6	4	46 000	29 000	1 480	–
34	18	47	68	138	Rp <sup>1/8</sup>	5	56 000	36 000	1 820	KASK12
34	18	65,1	73,7	138	Rp <sup>1/8</sup>	5	56 000	36 000	1 820	KASK12
38	21	74,6	82,4	160	M6	5	66 000	44 000	2 230	–
38	21	74,6	82,4	160	M6	5	66 000	44 000	2 230	–
38	21	77,8	82,5	160	M6	5	66 000	44 500	2 240	–



# Two-bolt flanged housing units

Flake graphite cast iron housing  
 Oval, narrow version  
 Adapter sleeve

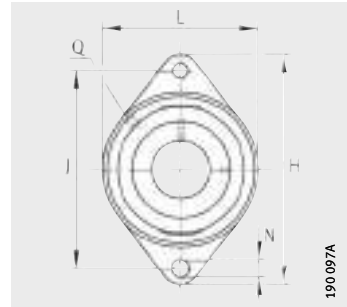

RCJTA...-XL-N



**Dimension table** - Dimensions in mm

Designation			Mass m ≈ kg	Dimensions					
Unit	Housing	Radial insert ball bearing		d	H	J	L	A	A <sub>1</sub>
<b>RCJTA20-XL-N</b>	CJT04	GSH20-XL-2RSR-B	0,52	<b>20</b>	112	90	61	28	10
<b>RCJTA25-XL-N</b>	CJT05	GSH25-XL-2RSR-B	0,54	<b>25</b>	124	99	70	26,5	11
<b>RCJTA30-XL-N</b>	CJT06	GSH30-XL-2RSR-B	0,77	<b>30</b>	142	116,5	80	29	12
<b>RCJTA35-XL-N</b>	CJT07	GSH35-XL-2RSR-B	1,06	<b>35</b>	155	130	92	30,5	12,5
<b>RCJTA40-XL-N</b>	CJT08	GSH40-XL-2RSR-B	1,46	<b>40</b>	172	143,5	105	34,5	13

<sup>1)</sup> To be ordered separately.  
 The caps are suitable for temperatures from -20 °C to +80 °C.



RCJTA...-XL-N

							Load carrying capacity Bearing			End cap <sup>1)</sup>
							Basic load ratings		Fatigue limit load C <sub>ur</sub> N	
A <sub>2</sub>	N	B <sub>1</sub>	U	V	Q	d <sub>3</sub> max.	dyn. C <sub>r</sub> N	stat. C <sub>0r</sub> N		
19	11,5	28	42,5	61	M6	32	13 400	7 000	355	KASK04
19	11,5	28	42,5	70	M6	38	14 400	8 100	410	KASK05
20	11,5	32	44	80	M6	45	20 100	11 600	590	KASK06
21	14	34	46	92	M6	52	26 500	15 700	800	KASK07
24	14	38	51	105	Rp <sup>1/8</sup>	58	31 000	19 700	1 000	KASK08



# Two-bolt flanged housing units

Flake graphite cast iron housing  
Oval, narrow version  
With centring spigot

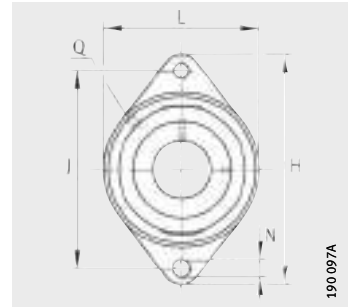

RCJTZ...-XL



**Dimension table** - Dimensions in mm

Designation			Mass m ≈ kg	Dimensions						
Unit	Housing	Radial insert ball bearing		d	H	J	L	A	A <sub>1</sub>	A <sub>2</sub>
<b>RCJTZ20-XL</b>	CJTZ04	GE20-XL-KRR-B	0,61	<b>20</b>	112,5	90	60,5	31,7	11	19
<b>RCJTZ25-XL</b>	CJTZ05	GE25-XL-KRR-B	0,76	<b>25</b>	124	99	70	26,5	12	19
<b>RCJTZ30-XL</b>	CJTZ06	GE30-XL-KRR-B	0,98	<b>30</b>	142	116,5	83	26	12	17
<b>RCJTZ35-XL</b>	CJTZ07	GE35-XL-KRR-B	1,32	<b>35</b>	155	130	94	26,5	12,5	17
<b>RCJTZ40-XL</b>	CJTZ08	GE40-XL-KRR-B	1,72	<b>40</b>	172	143,5	105	30,5	13	20
<b>RCJTZ45-XL</b>	CJTZ09	GE45-XL-KRR-B	1,94	<b>45</b>	180	148,5	111	31	13	20
<b>RCJTZ50-XL</b>	CJTZ10	GE50-XL-KRR-B	2,32	<b>50</b>	190	157	116	35	13	24
<b>RCJTZ60-XL</b>	CJTZ12	GE60-XL-KRR-B	3,9	<b>60</b>	238	202	138	42	16	30



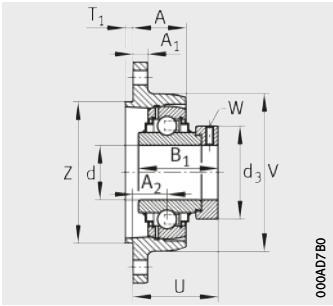

RCJTZ..XL

									Width across flats W	Load carrying capacity Bearing		
										Basic load ratings		Fatigue limit load C <sub>ur</sub> N
N	B <sub>1</sub>	T <sub>1</sub>	U	V	Z h8	Q	d <sub>3</sub> max.	dyn. C <sub>r</sub> N		stat. C <sub>0r</sub> N		
11,5	43,7	3,5	45,6	60,5	55	Rp1/8	33	3	13 600	6 600	335	
11,5	44,5	3,5	46	70	60	Rp1/8	37,5	3	14 900	7 800	395	
11,5	48,5	3	47,2	83	80	M6	44	4	20 700	11 300	570	
14	51,3	4	49,5	94	90	Rp1/8	55	5	27 500	15 300	770	
14	56,5	4	55,1	105	100	Rp1/8	58	5	34 500	19 800	1 010	
14	56,5	4	55,1	111	105	Rp1/8	63	5	34 500	20 400	1 030	
14	62,8	4	62,2	116	105	M6	69	5	37 500	23 200	1 180	
18	77,9	4	76,9	138	130	Rp1/8	84	5	56 000	36 000	1 820	



# Three-bolt flanged housing units

Flake graphite cast iron housing

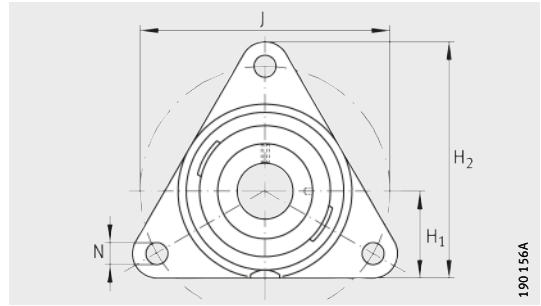

PCFTR...-XL

**Dimension table** - Dimensions in mm

Designation			Mass m ≈ kg	Dimensions					
Unit	Housing	Radial insert ball bearing		d	J	A	A <sub>1</sub>	A <sub>2</sub>	H <sub>1</sub>
<b>PCFTR15-XL</b>	CFTR03	GRAE15-XL-NPP-B	0,4	<b>15</b>	76,1	20	11	10	31
<b>PCFTR17-XL</b>	CFTR03	GRAE17-XL-NPP-B	0,4	<b>17</b>	76,1	20	11	10	31
<b>PCFTR20-XL</b>	CFTR04	GRAE20-XL-NPP-B	0,56	<b>20</b>	89,5	20	11	10,5	35
<b>PCFTR25-XL</b>	CFTR05	GRAE25-XL-NPP-B	0,71	<b>25</b>	96	22	12	12,5	36
<b>PCFTR30-XL</b>	CFTR06	GRAE30-XL-NPP-B	0,99	<b>30</b>	116	24	12	13,3	44
<b>PCFTR35-XL</b>	CFTR07	GRAE35-XL-NPP-B	1,39	<b>35</b>	129,7	27	14	15,6	48
<b>PCFTR40-XL</b>	CFTR08	GRAE40-XL-NPP-B	1,83	<b>40</b>	140	30	16	18,3	51
<b>PCFTR45-XL</b>	CFTR09	GRAE45-XL-NPP-B	2	<b>45</b>	160	33	16	19,2	55
<b>PCFTR50-XL</b>	CFTR10	GRAE50-XL-NPP-B	2,15	<b>50</b>	160	33	16	19,2	55

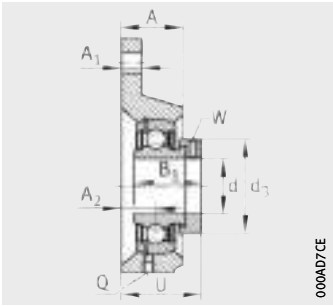

PCFTR..-XL

000A07CE

						Width across flats  W	Load carrying capacity Bearing		
							Basic load ratings		Fatigue limit load  C <sub>ur</sub>  N
H <sub>2</sub>	N	B <sub>1</sub>	U	Q	d <sub>3</sub> max.		dyn. C <sub>r</sub> N	stat. C <sub>0r</sub> N	
81	11,5	28,6	32,1	M6	28,4	3	10 100	4 750	241
81	11,5	28,6	32,1	M6	28,4	3	10 100	4 750	241
92	11,5	31	34	M6	33	3	13 600	6 600	335
97	11,5	31	36	M6	37,5	3	14 900	7 800	395
117	11,5	35,8	40	M6	44	4	20 700	11 300	570
128	14	39	45,1	M6	55	5	27 500	15 300	770
137	14	43,8	51	M6	58	5	34 500	19 800	1 010
150	14	43,8	51,9	M6	63	5	34 500	20 400	1 030
150	14	43,8	51,9	M6	69	5	37 500	23 200	1 180



# Four-bolt flanged housing units

Flake graphite cast iron housing  
 Square version  
 Eccentric locking collar

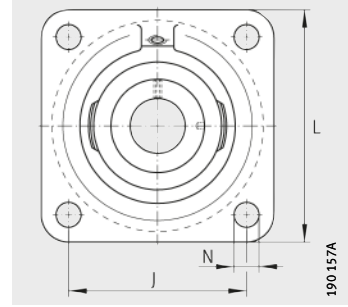

PCF..-XL, PCJ..-XL(-N),  
 RCJ..-XL(-N,-FA164),  
 TCJ..-XL-N, RCJO..-XL



**Dimension table** - Dimensions in mm

Designation			Mass m ≈ kg	Dimensions					
Unit	Housing	Radial insert ball bearing		d	J	L	A	A <sub>1</sub>	A <sub>2</sub>
PCJ12-XL	CJ03	GRAE12-XL-NPP-B	0,52	12	54	76	27	9,5	17
PCJ15-XL	CJ03	GRAE15-XL-NPP-B	0,52	15	54	76	27	9,5	17
PCJ17-XL	CJ03	GRAE17-XL-NPP-B	0,52	17	54	76	27	9,5	17
RCJ17-XL	CJ03	GE17-XL-KRR-B	0,56	17	54	76	27	9,5	17
PCF20-XL	CF04	GRAE20-XL-NPP-B	0,55	20	63,5	86	20	10	10,5
PCJ20-XL-N	CJ04	GRAE20-XL-NPP-B	0,6	20	63,5	86	29	10	19
RCJ20-XL-N	CJ04	GE20-XL-KRR-B	0,65	20	63,5	86	29	10	19
TCJ20-XL-N	CJ04	GE20-XL-KTT-B	0,65	20	63,5	86	29	10	19
PCF25-XL	CF05	GRAE25-XL-NPP-B	0,71	25	70	95	22	11	12,5
PCJ25-XL-N	CJ05	GRAE25-XL-NPP-B	0,76	25	70	95	29	11	19
RCJ25-XL-FA164 <sup>2)</sup>	CJ05	GE25-XL-KRR-B-FA164	0,82	25	70	95	29	11	19
RCJ25-XL-N	CJ05	GE25-XL-KRR-B	0,82	25	70	95	29	11	19
TCJ25-XL-N	CJ05	GE25-XL-KTT-B	0,81	25	70	95	29	11	19
PCF30-XL	CF06	GRAE30-XL-NPP-B	1,01	30	82,5	108	22,3	12	13,3
PCJ30-XL-N	CJ06	GRAE30-XL-NPP-B	1,11	30	82,5	108	29	12	20
RCJ30-XL-N	CJ06	GE30-XL-KRR-B	1,16	30	82,5	108	29	12	20
RCJO30-XL	CJO06	GNE30-XL-KRR-B	1,75	30	95	125	30,6	15	20,6
TCJ30-XL-N	CJ06	GE30-XL-KTT-B	1,17	30	82,5	108	29	12	20
PCF35-XL	CF07	GRAE35-XL-NPP-B	1,34	35	92	118	25	12,5	15,5
PCJ35-XL-N	CJ07	GRAE35-XL-NPP-B	1,47	35	92	118	30,5	12,5	21
RCJ35-XL-FA164 <sup>2)</sup>	CJ07	GE35-XL-KRR-B-FA164	1,57	35	92	118	30,5	12,5	21
RCJ35-XL-N	CJ07	GE35-XL-KRR-B	1,55	35	92	118	30,5	12,5	21
RCJO35-XL	CJO07	GNE35-XL-KRR-B	2,55	35	100	135	31	16	20
TCJ35-XL-N	CJ07	GE35-XL-KTT-B	1,53	35	92	118	30,5	12,5	21

1) To be ordered separately.  
 The caps are suitable for temperatures from -20 °C to +80 °C.  
 2) With fitted lubrication nipple.

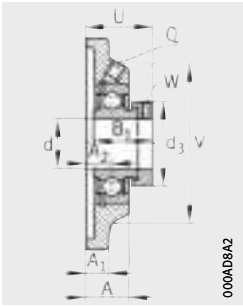

00040842

PCF..-XL

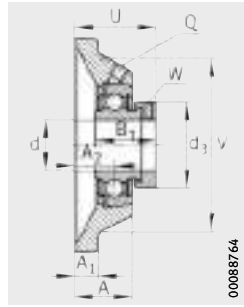

00088764

PCJ..-XL(-N)

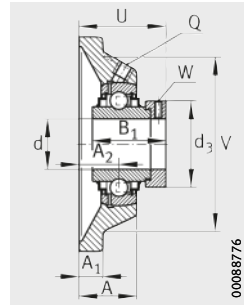

00088776

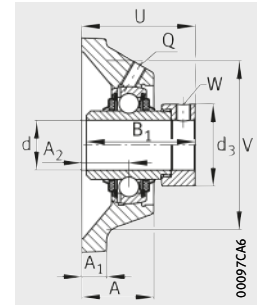
RCJ..-XL(-N,-FA164),  
RCJO..-XL

00097C46

TCJ..-XL-N

N	B <sub>1</sub>	U	V	Q	d <sub>3</sub> max.	W	Load carrying capacity Bearing			End cap <sup>1)</sup>
							Basic load ratings		Fatigue limit load C <sub>ur</sub> N	
							dyn. C <sub>r</sub> N	stat. C <sub>0r</sub> N		
11,5	28,6	39,1	58	M6	28,4	3	10 100	4 750	241	–
11,5	28,6	39,1	58	M6	28,4	3	10 100	4 750	241	–
11,5	28,6	39,1	58	M6	28,4	3	10 100	4 750	241	–
11,5	37,4	40,4	58	M6	28,4	3	10 100	4 750	241	–
11,5	31	34	68	M6	33	3	13 600	6 600	335	–
11,5	31	42,5	68	M6	33	3	13 600	6 600	335	KASK04
11,5	43,7	45,6	68	M6	33	3	13 600	6 600	335	KASK04
11,5	43,7	45,6	68	M6	33	3	13 600	6 600	335	KASK04
11,5	31	36	74	M6	37,5	3	14 900	7 800	395	–
11,5	31	42,5	74	M6	37,5	3	14 900	7 800	395	KASK05
11,5	44,5	46	74	M6	37,5	3	14 900	7 800	395	–
11,5	44,5	46	74	M6	37,5	3	14 900	7 800	395	KASK05
11,5	44,5	46	74	M6	37,5	3	14 900	7 800	395	KASK05
11,5	35,8	40	85	M6	44	4	20 700	11 300	570	–
11,5	35,8	46,8	85	M6	44	4	20 700	11 300	570	KASK06
11,5	48,5	50,2	85	M6	44	4	20 700	11 300	570	KASK06
14,5	50,2	53,1	98	M6	51	5	31 500	16 700	840	–
11,5	48,5	50,2	85	M6	44	4	20 700	11 300	570	KASK06
14	39	45	100	M6	55	5	27 500	15 300	770	–
14	39	50,5	100	M6	55	5	27 500	15 300	770	KASK07
14	51,3	53,5	100	M6	55	5	27 500	15 300	770	–
14	51,3	53,5	100	M6	55	5	27 500	15 300	770	KASK07
19	51,6	53,4	104	M6	55	5	39 000	20 900	1 060	–
14	51,3	53,5	100	M6	55	5	27 500	15 300	770	KASK07



# Four-bolt flanged housing units

Flake graphite cast iron housing  
 Square version  
 Eccentric locking collar

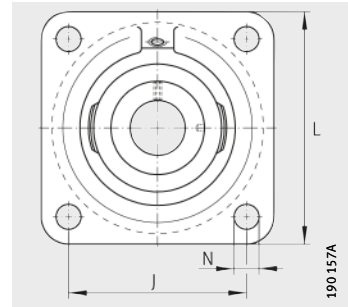

PCF...-XL, PCJ...-XL(-N),  
 RCJ...-XL(-N,-FA164),  
 TCJ...-XL-N, RCJO...-XL



**Dimension table** (continued) · Dimensions in mm

Designation			Mass	Dimensions						
Unit	Housing	Radial insert ball bearing		m	d	J	L	A	A <sub>1</sub>	A <sub>2</sub>
			≈ kg							
<b>PCF40-XL</b>	CF08	GRAE40-XL-NPP-B	1,72	<b>40</b>	101,5	130	28,8	13	18,3	
<b>PCJ40-XL-N</b>	CJ08	GRAE40-XL-NPP-B	1,89	<b>40</b>	101,5	130	34,5	13	24	
<b>RCJ40-XL-FA164<sup>2)</sup></b>	CJ08	GE40-XL-KRR-B-FA164	2,02	<b>40</b>	101,5	130	34,5	13	24	
<b>RCJ40-XL-N</b>	CJ08	GE40-XL-KRR-B	2,02	<b>40</b>	101,5	130	34,5	13	24	
<b>RCJO40-XL</b>	CJO08	GE40-XL-KRR-B	3,1	<b>40</b>	112	150	34,5	17	23	
<b>TCJ40-XL-N</b>	CJ08	GE40-XL-KTT-B	2,02	<b>40</b>	101,5	130	34,5	13	24	
<b>PCF45-XL</b>	CF09	GRAE45-XL-NPP-B	1,99	<b>45</b>	105	137	30,2	13	19,2	
<b>PCJ45-XL</b>	CJ09	GRAE45-XL-NPP-B	2,22	<b>45</b>	105	137	35	13	24	
<b>RCJ45-XL</b>	CJ09	GE45-XL-KRR-B	2,26	<b>45</b>	105	137	35	13	24	
<b>TCJ45-XL</b>	CJ09	GE45-XL-KTT-B	2,37	<b>45</b>	105	137	35	13	24	
<b>PCF50-XL</b>	CF10	GRAE50-XL-NPP-B	2,2	<b>50</b>	111	143	30,2	13	19,2	
<b>PCJ50-XL-N</b>	CJ10	GRAE50-XL-NPP-B	2,3	<b>50</b>	111	143	41	13	28	
<b>RCJ50-XL-FA164<sup>2)</sup></b>	CJ10	GE50-XL-KRR-B-FA164	2,53	<b>50</b>	111	143	41	13	28	
<b>RCJ50-XL-N</b>	CJ10	GE50-XL-KRR-B	2,53	<b>50</b>	111	143	41	13	28	
<b>RCJO50-XL</b>	CJO10	GNE50-XL-KRR-B	4,9	<b>50</b>	132	175	42,5	19	28	
<b>TCJ50-XL-N</b>	CJ10	GE50-XL-KTT-B	2,53	<b>50</b>	111	143	41	13	28	
<b>PCJ55-XL</b>	CJ11	GRAE55-XL-NPP-B	2,91	<b>55</b>	130	162	43,5	15	31	
<b>RCJ55-XL</b>	CJ11	GE55-XL-KRR-B	3,52	<b>55</b>	130	162	43,5	15	31	
<b>TCJ55-XL</b>	CJ11	GE55-XL-KTT-B	3,57	<b>55</b>	130	162	43,5	15	31	
<b>PCJ60-XL-N</b>	CJ12	GRAE60-XL-NPP-B	4,1	<b>60</b>	143	175	47,5	16	34	
<b>RCJ60-XL-FA164<sup>2)</sup></b>	CJ12	GE60-XL-KRR-B-FA164	4,26	<b>60</b>	143	175	47,5	16	34	
<b>RCJ60-XL-N</b>	CJ12	GE60-XL-KRR-B	4,21	<b>60</b>	143	175	47,5	16	34	
<b>RCJO60-XL</b>	CJO12	GNE60-XL-KRR-B	6,8	<b>60</b>	150	195	49,5	22	33	
<b>TCJ60-XL-N</b>	CJ12	GE60-XL-KTT-B	4,21	<b>60</b>	143	175	47,5	16	34	

1) To be ordered separately.  
 The caps are suitable for temperatures from -20 °C to +80 °C.  
 2) With fitted lubrication nipple.

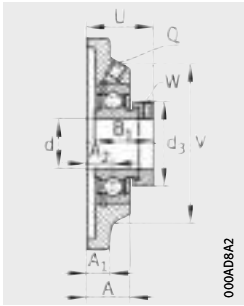

00040842

PCF..-XL

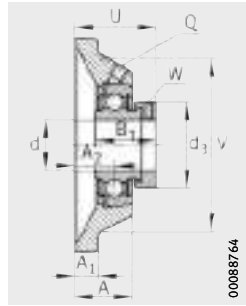

00088764

PCJ..-XL(-N)

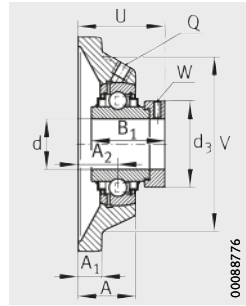

00088776

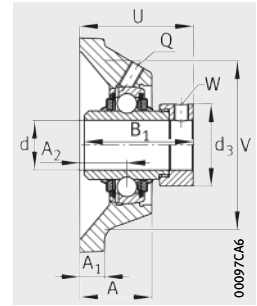
RCJ..-XL(-N,-FA164),  
RCJO..-XL

00097C46

TCJ..-XL-N

N	B <sub>1</sub>	U	V	Q	d <sub>3</sub> max.	W	Load carrying capacity Bearing			End cap <sup>1)</sup>
							Basic load ratings		Fatigue limit load C <sub>ur</sub> N	
							dyn. C <sub>r</sub> N	stat. C <sub>0r</sub> N		
14	43,8	51	110	M6	58	5	34 500	19 800	1 010	–
14	43,8	56,8	110	M6	58	5	34 500	19 800	1 010	KASK08
14	56,5	59,1	110	M6	58	5	34 500	19 800	1 010	–
14	56,5	59,1	110	M6	58	5	34 500	19 800	1 010	KASK08
19	54,6	59,6	121	M6	63	5	47 000	26 000	1 320	–
14	56,5	59,1	110	M6	58	5	34 500	19 800	1 010	KASK08
14	43,8	51,9	116	M6	63	5	34 500	20 400	1 030	–
14	43,8	56,7	116	Rp <sup>1/8</sup>	63	5	34 500	20 400	1 030	–
14	56,5	59,1	116	Rp <sup>1/8</sup>	63	5	34 500	20 400	1 030	–
14	56,5	59,1	116	Rp <sup>1/8</sup>	63	5	34 500	20 400	1 030	–
14	43,8	51,4	125	Rp <sup>1/8</sup>	69	5	37 500	23 200	1 180	–
18	43,8	60,8	119	M6	69	5	37 500	23 200	1 180	KASK10
18	62,8	66,2	119	M6	69	5	37 500	23 200	1 180	–
18	62,8	66,2	119	M6	69	5	37 500	23 200	1 180	KASK10
23	66,75	70,1	144	M6	75,8	5	66 000	38 000	1 920	–
18	62,8	66,2	119	M6	69	5	37 500	23 200	1 180	KASK10
18	48,4	67,4	140	Rp <sup>1/8</sup>	76	5	46 000	29 000	1 480	–
18	71,4	74,6	140	Rp <sup>1/8</sup>	76	5	46 000	29 000	1 480	–
18	71,4	74,6	140	Rp <sup>1/8</sup>	76	5	46 000	29 000	1 480	–
18	53,1	73,6	150	Rp <sup>1/8</sup>	84	5	56 000	36 000	1 820	KASK12
18	77,9	80,9	150	Rp <sup>1/8</sup>	84	5	56 000	36 000	1 820	–
18	77,9	80,9	150	Rp <sup>1/8</sup>	84	5	56 000	36 000	1 820	KASK12
23	68	78,4	170	M6	89	5	87 000	52 000	2 650	–
18	77,9	80,9	150	Rp <sup>1/8</sup>	84	5	56 000	36 000	1 820	KASK12



# Four-bolt flanged housing units

Flake graphite cast iron housing  
 Square version  
 Eccentric locking collar

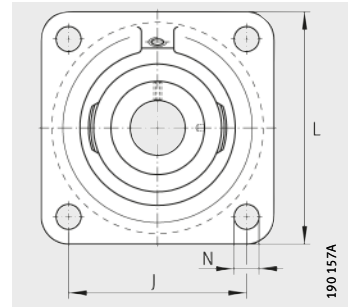

PCF..-XL, PCJ..-XL(-N),  
 RCJ..-XL(-N,-FA164), TCJ..-XL-N,  
 RCJO..-XL



**Dimension table** (continued) · Dimensions in mm

Designation			Mass m ≈ kg	Dimensions				
Unit	Housing	Radial insert ball bearing		d	J	L	A	A <sub>1</sub>
<b>RCJ65-214-XL</b> <sup>3)</sup>	CJ14	GE65-214-XL-KRR-B	6,11	<b>65</b>	150	188	52	18
<b>RCJ65-214-XL-FA164</b> <sup>2)3)</sup>	CJ14	GE65-214-XL-KRR-B-FA164	6,11	<b>65</b>	150	188	52	18
<b>TCJ65-214-XL</b> <sup>3)</sup>	CJ14	GE65-214-XL-KTT-B	6,11	<b>65</b>	150	188	52	18
<b>RCJ70-XL</b>	CJ14	GE70-XL-KRR-B	5,85	<b>70</b>	150	188	52	18
<b>RCJO70-XL</b>	CJO14	GENE70-XL-KRR-B	10	<b>70</b>	178	226	54,5	25
<b>TCJ70-XL</b>	CJ14	GE70-XL-KTT-B	5,85	<b>70</b>	150	188	52	18
<b>RCJ75-XL</b>	CJ15	GE75-XL-KRR-B	6,5	<b>75</b>	153	197	55,8	20
<b>TCJ75-XL</b>	CJ15	GE75-XL-KTT-B	6,5	<b>75</b>	153	197	55,8	20
<b>RCJ80-XL</b>	CJ16	GE80-XL-KRR-B	6,85	<b>80</b>	153	197	55,8	20
<b>RCJO80-XL</b>	CJO16	GENE80-XL-KRR-B	17,15	<b>80</b>	196	250	80	25
<b>TCJ80-XL</b>	CJ16	GE80-XL-KTT-B	6,85	<b>80</b>	153	197	55,8	20
<b>RCJ90-XL</b>	CJ18	GE90-XL-KRR-B	9	<b>90</b>	187	235	39,8	22
<b>RCJO90-XL</b>	CJO18	GENE90-XL-KRR-B	21,6	<b>90</b>	216	280	85	28,5
<b>RCJ100-XL</b>	CJ20	GE100-XL-KRR-B	12,25	<b>100</b>	210	265	46	25
<b>RCJO100-XL</b>	CJO20	GENE100-XL-KRR-B	33,6	<b>100</b>	242	310	97	32
<b>RCJ120-XL</b>	CJ24	GE120-XL-KRR-B	18	<b>120</b>	240	305	51	28

- 1) To be ordered separately.  
The caps are suitable for temperatures from -20 °C to +80 °C.
- 2) With fitted lubrication nipple.
- 3) Alternative ball set 6214.



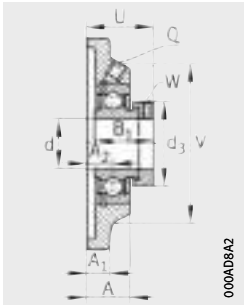

000408A2

PCF..-XL

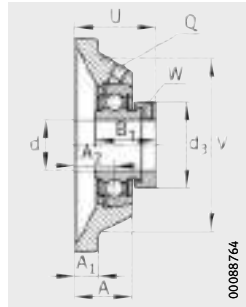

00088764

PCJ..-XL(-N)

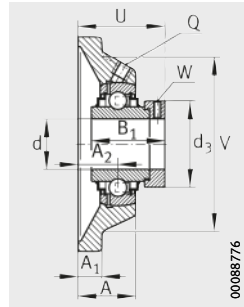

00088776

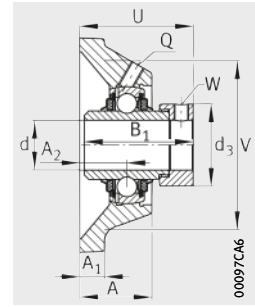
RCJ..-XL(-N,-FA164),  
RCJO..-XL

00097CA6

TCJ..-XL-N

A <sub>2</sub>	N	B <sub>1</sub>	U	V	Q	d <sub>3</sub> max.	W	Load carrying capacity Bearing			End cap <sup>1)</sup>
								Basic load ratings		Fatigue limit load C <sub>ur</sub> N	
								dyn. C <sub>r</sub> N	stat. C <sub>0r</sub> N		
38	18	66	82,6	165	Rp <sup>1/8</sup>	96	6	66 000	44 000	2 230	–
38	18	66	82,6	165	Rp <sup>1/8</sup>	96	6	66 000	44 000	2 230	–
38	18	66	82,6	165	Rp <sup>1/8</sup>	96	6	66 000	44 000	2 230	–
38	18	66	82,5	165	Rp <sup>1/8</sup>	96	6	66 000	44 000	2 230	–
36	25	75,5	85,4	196	M6	102	6	111 000	68 000	3 300	–
38	18	66	82,6	165	Rp <sup>1/8</sup>	96	6	66 000	44 000	2 230	–
41,3	23	67	86,9	170	M6	100	6	66 000	44 500	2 240	–
41,3	23	67	86,9	170	M6	100	6	66 000	44 500	2 240	–
41,3	23	70,7	88,9	180	Rp <sup>1/8</sup>	108	6	76 000	54 000	2 600	–
50	28	93,6	109,7	210	M6	118	6	131 000	87 000	3 950	–
41,3	23	70,7	88,9	180	Rp <sup>1/8</sup>	108	6	76 000	54 000	2 600	–
23,8	23	69,5	70,3	200	Rp <sup>1/8</sup>	118	6	109 000	79 000	3 550	–
48,5	28	101	114	230	M6	132	6	151 000	107 000	4 600	–
28	27	75	77,5	230	M6	132	6	130 000	93 000	4 000	–
55	32	109,4	125	268	Rp <sup>1/8</sup>	145	6	184 000	141 000	5 700	–
31	30	81	83	270	Rp <sup>1/8</sup>	152	6	165 000	131 000	5 100	–



# Four-bolt flanged housing units

Flake graphite cast iron housing  
 Square version  
 Grub screws in inner ring or drive slot

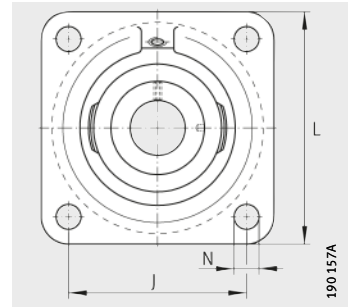

PCJY...-XL(-N), RCJY...-XL(-N),  
 RCJL...-XL-N



**Dimension table** - Dimensions in mm

Designation			Mass m ≈ kg	Dimensions					
Unit	Housing	Radial insert ball bearing		d	J	L	A	A <sub>1</sub>	A <sub>2</sub>
PCJY12-XL	CJ03	GAY12-XL-NPP-B	0,5	12	54	76	27	9,5	17
RCJY12-XL	CJ03	GYE12-XL-KRR-B	0,51	12	54	76	27	9,5	17
PCJY15-XL	CJ03	GAY15-XL-NPP-B	0,49	15	54	76	27	9,5	17
RCJY15-XL	CJ03	GYE15-XL-KRR-B	0,51	15	54	76	27	9,5	17
RCJY16-XL	CJ03	GYE16-XL-KRR-B	0,51	16	54	76	27	9,5	17
PCJY17-XL	CJ03	GAY17-XL-NPP-B	0,48	17	54	76	27	9,5	17
RCJY17-XL	CJ03	GYE17-XL-KRR-B	0,51	17	54	76	27	9,5	17
PCJY20-XL-N	CJ04	GAY20-XL-NPP-B	0,56	20	63,5	86	29	10	19
RCJY20-XL-N	CJ04	GYE20-XL-KRR-B	0,62	20	63,5	86	29	10	19
PCJY25-XL-N	CJ05	GAY25-XL-NPP-B	0,72	25	70	95	29	11	19
RCJY25-XL-N	CJ05	GYE25-XL-KRR-B	0,77	25	70	95	29	11	19
PCJY30-XL-N	CJ06	GAY30-XL-NPP-B	1,03	30	82,5	108	29	12	20
RCJL30-XL-N <sup>2)</sup>	CJ06	GLE30-XL-KRR-B	1,08	30	82,5	108	29	12	20
RCJY30-XL-N	CJ06	GYE30-XL-KRR-B	1,1	30	82,5	108	29	12	20
PCJY35-XL-N	CJ07	GAY35-XL-NPP-B	1,38	35	92	118	30,5	12,5	21
RCJL35-XL-N <sup>2)</sup>	CJ07	GLE35-XL-KRR-B	1,4	35	92	118	30,5	12,5	21
RCJY35-XL-N	CJ07	GYE35-XL-KRR-B	1,44	35	92	118	30,5	12,5	21
PCJY40-XL-N	CJ08	GAY40-XL-NPP-B	1,81	40	101,5	130	34,5	13	24
RCJL40-XL-N <sup>2)</sup>	CJ08	GLE40-XL-KRR-B	1,84	40	101,5	130	34,5	13	24
RCJY40-XL-N	CJ08	GYE40-XL-KRR-B	1,93	40	101,5	130	34,5	13	24
PCJY45-XL	CJ09	GAY45-XL-NPP-B	2	45	105	137	35	13	24
RCJY45-XL	CJ09	GYE45-XL-KRR-B	2,15	45	105	137	35	13	24

1) To be ordered separately.  
 The caps are suitable for temperatures from -20 °C to +80 °C.

2) With fitted lubrication nipple.

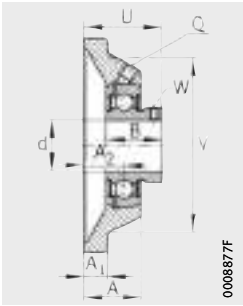

PCJY..-XL(-N)

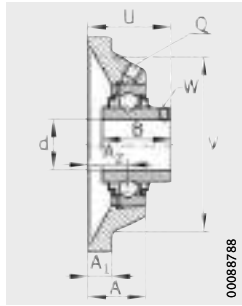

RCJY..-XL(-N)

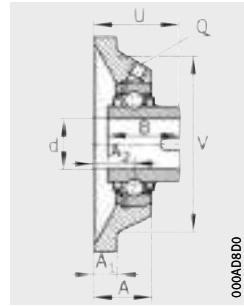

RCJL..-XL-N

					Width across flats W	Load carrying capacity Bearing			End cap <sup>1)</sup>
						Basic load ratings		Fatigue limit load C <sub>ur</sub> N	
N	B	U	V	Q		dyn. C <sub>r</sub> N	stat. C <sub>0r</sub> N		
11,5	22	33	58	M6	2,5	10 100	4 750	241	–
11,5	27,4	32,9	58	M6	2,5	10 100	4 750	241	–
11,5	22	33	58	M6	2,5	10 100	4 750	241	–
11,5	27,4	32,9	58	M6	2,5	10 100	4 750	241	–
11,5	27,4	32,9	58	M6	2,5	10 100	4 750	241	–
11,5	22	33	58	M6	2,5	10 100	4 750	241	–
11,5	27,4	32,9	58	M6	2,5	10 100	4 750	241	–
11,5	25	37	68	M6	2,5	13 600	6 600	335	KASK04
11,5	31	37,3	68	M6	2,5	13 600	6 600	335	KASK04
11,5	27	38,5	74	M6	2,5	14 900	7 800	395	KASK05
11,5	34,1	38,8	74	M6	2,5	14 900	7 800	395	KASK05
11,5	30	41	85	M6	3	20 700	11 300	570	KASK06
11,5	36,5	42	85	M6	–	20 700	11 300	570	KASK06
11,5	38,1	42,2	85	M6	3	20 700	11 300	570	KASK06
14	35	46,45	100	M6	3	27 500	15 300	770	KASK07
14	37,7	43	100	M6	–	27 500	15 300	770	KASK07
14	42,9	46,4	100	M6	3	27 500	15 300	770	KASK07
14	39,5	52,95	110	M6	4	34 500	19 800	1 010	KASK08
14	42,9	51	110	M6	–	34 500	19 800	1 010	KASK08
14	49,2	54,2	110	M6	4	34 500	19 800	1 010	KASK08
14	41,5	54,5	116	Rp <sup>1/8</sup>	4	34 500	20 400	1 030	–
14	49,2	54,2	116	Rp <sup>1/8</sup>	4	34 500	20 400	1 030	–



# Four-bolt flanged housing units

Flake graphite cast iron housing  
 Square version  
 Grub screws in inner ring or drive slot

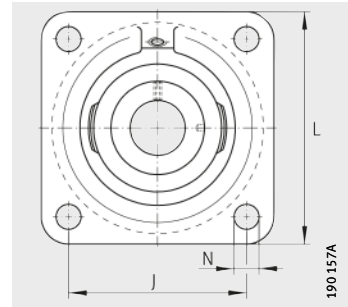

PCJY..-XL-N, RCJY..-XL(-N),  
 RCJL..-XL(-N)



**Dimension table** (continued) · Dimensions in mm

Designation			Mass m ≈ kg	Dimensions				
Unit	Housing	Radial insert ball bearing		d	J	L	A	A <sub>1</sub>
<b>PCJY50-XL-N</b>	CJ10	GAY50-XL-NPP-B	2,2	<b>50</b>	111	143	41	13
<b>RCJL50-XL-N<sup>2)</sup></b>	CJ10	GLE50-XL-KRR-B	2,29	<b>50</b>	111	143	41	13
<b>RCJY50-XL-N</b>	CJ10	GYE50-XL-KRR-B	2,33	<b>50</b>	111	143	41	13
<b>RCJY55-XL</b>	CJ11	GYE55-XL-KRR-B	3,41	<b>55</b>	130	162	43,5	15
<b>PCJY60-XL-N</b>	CJ12	GAY60-XL-NPP-B	3,59	<b>60</b>	143	175	47,5	16
<b>RCJL60-XL-N<sup>2)</sup></b>	CJ12	GLE60-XL-KRR-B	4,22	<b>60</b>	143	175	47,5	16
<b>RCJY60-XL-N</b>	CJ12	GYE60-XL-KRR-B	4,22	<b>60</b>	143	175	47,5	16
<b>RCJY65-214-XL<sup>3)</sup></b>	CJ14	GYE65-214-XL-KRR-B	5,65	<b>65</b>	150	188	52	18
<b>RCJL70-XL<sup>2)</sup></b>	CJ14	GLE70-XL-KRR-B	5,65	<b>70</b>	150	188	52	18
<b>RCJY70-XL</b>	CJ14	GYE70-XL-KRR-B	5,35	<b>70</b>	150	188	52	18
<b>RCJY75-XL</b>	CJ15	GYE75-XL-KRR-B	6,04	<b>75</b>	153	197	55,8	20
<b>RCJY80-XL</b>	CJ16	GYE80-XL-KRR-B	6,82	<b>80</b>	153	197	55,8	20
<b>RCJY90-XL</b>	CJ18	GYE90-XL-KRR-B	9,48	<b>90</b>	187	235	39,8	22

- 1) To be ordered separately.  
The caps are suitable for temperatures from -20 °C to +80 °C.
- 2) With fitted lubrication nipple.
- 3) Alternative ball set 6214.

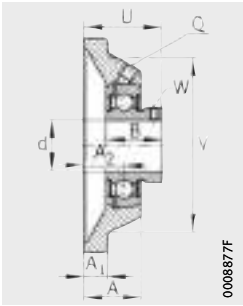

PCJY..-XL-N

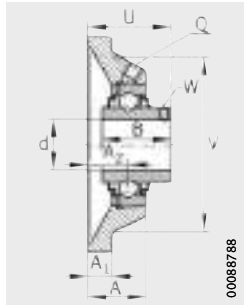

RCJY..-XL(-N)

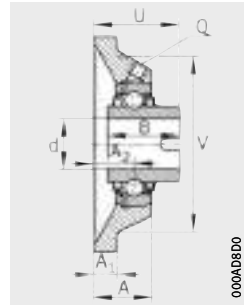

RCJL..-XL(-N)

						Width across flats W	Load carrying capacity Bearing			End cap <sup>1)</sup>
							Basic load ratings		Fatigue limit load C <sub>ur</sub> N	
A <sub>2</sub>	N	B	U	V	Q		dyn. C <sub>r</sub> N	stat. C <sub>0r</sub> N		
28	18	43	60	119	M6	4	37 500	23 200	1 180	KASK10
28	18	49,2	58,2	119	M6	–	37 500	23 200	1 180	KASK10
28	18	51,6	60,6	119	M6	4	37 500	23 200	1 180	KASK10
31	18	55,6	64,4	140	Rp <sup>1/8</sup>	4	46 000	29 000	1 480	–
34	18	47	68	150	Rp <sup>1/8</sup>	5	56 000	36 000	1 820	KASK12
34	18	61,9	71,3	150	Rp <sup>1/8</sup>	–	56 000	36 000	1 820	KASK12
34	18	65,1	73,7	150	Rp <sup>1/8</sup>	5	56 000	36 000	1 820	KASK12
38	18	74,6	82,4	165	Rp <sup>1/8</sup>	5	66 000	44 000	2 230	–
38	18	68,2	79,2	165	Rp <sup>1/8</sup>	–	66 000	44 000	2 230	–
38	18	74,6	82,4	165	Rp <sup>1/8</sup>	5	66 000	44 000	2 230	–
41,3	23	77,8	85,8	170	M6	5	66 000	44 500	2 240	–
41,3	23	82,6	90,6	180	Rp <sup>1/8</sup>	5	76 000	54 000	2 600	–
23,8	23	96	80,1	200	Rp <sup>1/8</sup>	6	109 000	79 000	3 550	–



# Four-bolt flanged housing units

Flake graphite cast iron housing  
Round version  
With wide centring spigot  
Eccentric locking collar

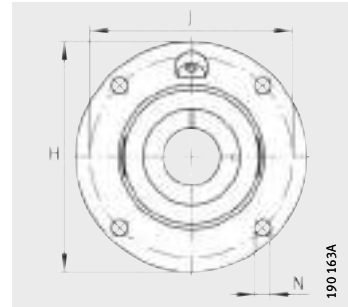

PME..-XL, RME..-XL, RMEO..-XL,  
TME..-XL

**X-life**

**Dimension table** - Dimensions in mm

Designation			Mass	Dimensions						
Unit	Housing	Radial insert ball bearing		m ≈ kg	d	H	J	A	A <sub>1</sub>	A <sub>2</sub>
<b>PME20-XL-N</b>	ME04	GRAE20-XL-NPP-B	0,53	<b>20</b>	100	78	17	8	2	9
<b>RME20-XL-N</b>	ME04	GE20-XL-KRR-B	0,57	<b>20</b>	100	78	17	8	2	9
<b>TME20-XL-N</b>	ME04	GE20-XL-KTT-B	0,56	<b>20</b>	100	78	17	8	2	9
<b>PME25-XL-N</b>	ME05	GRAE25-XL-NPP-B	0,73	<b>25</b>	115	90	19	9	2,5	9
<b>RME25-XL-N</b>	ME05	GE25-XL-KRR-B	0,8	<b>25</b>	115	90	19	9	2,5	9
<b>TME25-XL-N</b>	ME05	GE25-XL-KTT-B	0,8	<b>25</b>	115	90	19	9	2,5	9
<b>PME30-XL-N</b>	ME06	GRAE30-XL-NPP-B	0,97	<b>30</b>	125	100	20,5	9,5	2	11,5
<b>RME30-XL-N</b>	ME06	GE30-XL-KRR-B	1,04	<b>30</b>	125	100	20,5	9,5	2	11,5
<b>TME30-XL-N</b>	ME06	GE30-XL-KTT-B	1,05	<b>30</b>	125	100	20,5	9,5	2	11,5
<b>PME35-XL-N</b>	ME07	GRAE35-XL-NPP-B	1,26	<b>35</b>	135	110	20,5	10	1	11,5
<b>RME35-XL-N</b>	ME07	GE35-XL-KRR-B	1,34	<b>35</b>	135	110	20,5	10	1	11,5
<b>RMEO35-XL</b>	ME007	GNE35-XL-KRR-B	2,4	<b>35</b>	174	141	25	16	-2	19
<b>TME35-XL-N</b>	ME07	GE35-XL-KTT-B	1,34	<b>35</b>	135	110	20,5	10	1	11,5
<b>PME40-XL-N</b>	ME08	GRAE40-XL-NPP-B	1,62	<b>40</b>	145	120	23	11,5	1	11,5
<b>RME40-XL-N</b>	ME08	GE40-XL-KRR-B	1,74	<b>40</b>	145	120	23	11,5	1	11,5
<b>RMEO40-XL</b>	ME008	GNE40-XL-KRR-B	3,4	<b>40</b>	194	158	27	17	-2,5	19
<b>TME40-XL-N</b>	ME08	GE40-XL-KTT-B	1,77	<b>40</b>	145	120	23	11,5	1	11,5
<b>PME45-XL</b>	ME09	GRAE45-XL-NPP-B	1,93	<b>45</b>	155	130	25	12	2	14
<b>RME45-XL</b>	ME09	GE45-XL-KRR-B	2,05	<b>45</b>	155	130	25	12	2	14
<b>TME45-XL</b>	ME09	GE45-XL-KTT-B	2,1	<b>45</b>	155	130	25	12	2	14
<b>PME50-XL-N</b>	ME10	GRAE50-XL-NPP-B	2,13	<b>50</b>	165	135	25	13	1	14
<b>RME50-XL-N</b>	ME10	GE50-XL-KRR-B	2,53	<b>50</b>	165	135	25	13	1	14
<b>RMEO50-XL</b>	ME010	GNE50-XL-KRR-B	4,6	<b>50</b>	230	187	31	19	-2,5	23
<b>TME50-XL-N</b>	ME10	GE50-XL-KTT-B	2,59	<b>50</b>	165	135	25	13	1	14
<b>PME55-XL</b>	ME11	GRAE55-XL-NPP-B	2,76	<b>55</b>	185	150	27,5	15	-	18
<b>RME55-XL</b>	ME11	GE55-XL-KRR-B	3,37	<b>55</b>	185	150	27,5	15	-	18
<b>TME55-XL</b>	ME11	GE55-XL-KTT-B	3,38	<b>55</b>	185	150	27,5	15	-	18

<sup>1)</sup> To be ordered separately.  
The caps are suitable for temperatures from -20 °C to +80 °C.

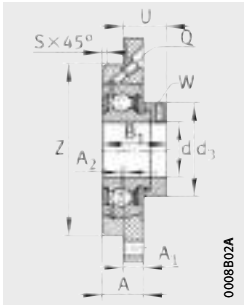

PME..-XL

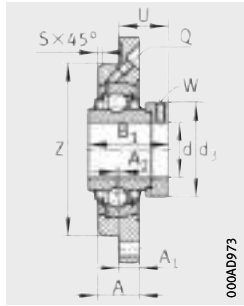

RME..-XL, RMEO..-XL

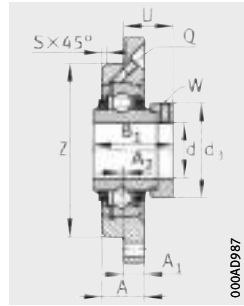

TME..-XL

B <sub>1</sub>	S	U	Z	Q	d <sub>3</sub> max.	W	Load carrying capacity Bearing			End cap <sup>1)</sup>
							Basic load ratings		Fatigue limit load C <sub>ur</sub> N	
							dyn. C <sub>r</sub> N	stat. C <sub>0r</sub> N		
31	2	21,5	62	M6	33	3	13 600	6 600	335	KASK04
43,7	2	24,6	62	M6	33	3	13 600	6 600	335	KASK04
43,7	2	24,6	62	M6	33	3	13 600	6 600	335	KASK04
31	2	21	70	M6	37,5	3	14 900	7 800	395	KASK05
44,5	2	24,4	70	M6	37,5	3	14 900	7 800	395	KASK05
44,5	2	24,4	70	M6	37,5	3	14 900	7 800	395	KASK05
35,8	2	24,7	80	M6	44	4	20 700	11 300	570	KASK06
48,5	2	28,1	80	M6	44	4	20 700	11 300	570	KASK06
48,5	2	28,1	80	M6	44	4	20 700	11 300	570	KASK06
39	2	28,5	90	M6	55	5	27 500	15 300	770	KASK07
51,3	2	31,3	90	M6	55	5	27 500	15 300	770	KASK07
51,6	2	35,35	100	M6	55	5	39 000	20 900	1 060	–
51,3	2	31,3	90	M6	55	5	27 500	15 300	770	KASK07
43,8	2	31,7	100	M6	58	5	34 500	19 800	1 010	KASK08
56,5	2	33,9	100	M6	58	5	34 500	19 800	1 010	KASK08
54,6	2	39,1	115	M6	63	5	47 000	26 000	1 320	–
56,5	2	33,9	100	M6	58	5	34 500	19 800	1 010	KASK08
43,8	2	30,7	105	M6	63	5	34 500	20 400	1 030	–
56,5	2	32,9	105	M6	63	5	34 500	20 400	1 030	–
56,5	2	32,9	105	M6	63	5	34 500	20 400	1 030	–
43,8	3	31,8	110	M8×1	69	5	37 500	23 200	1 180	KASK10
62,8	3	37,1	110	M8×1	69	5	37 500	23 200	1 180	KASK10
66,75	2	44,6	140	M6	75,8	5	66 000	38 000	1 920	–
62,8	3	37,1	110	M8×1	69	5	37 500	23 200	1 180	KASK10
48,4	3	36,4	125	M6	76	5	46 000	29 000	1 480	–
71,4	3	43,6	125	M6	76	5	46 000	29 000	1 480	–
71,4	3	43,6	125	M6	76	5	46 000	29 000	1 480	–



# Four-bolt flanged housing units

Flake graphite cast iron housing  
 Round version  
 With wide centring spigot  
 Eccentric locking collar

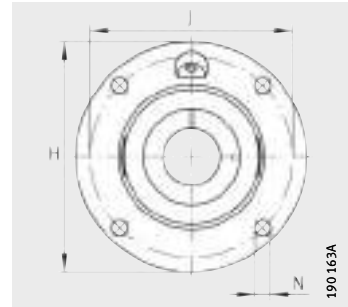

PME..-XL, RME..-XL, RMEO..-XL,  
 TME..-XL



**Dimension table** (continued) · Dimensions in mm

Designation			Mass m ≈ kg	Dimensions					
Unit	Housing	Radial insert ball bearing		d	H	J	A	A <sub>1</sub>	A <sub>2</sub>
<b>PME60-XL-N</b>	ME12	GRAE60-XL-NPP-B	3,65	<b>60</b>	195	160	29	16	1
<b>RME60-XL-N</b>	ME12	GE60-XL-KRR-B	4,04	<b>60</b>	195	160	29	16	1
<b>RMEO60-XL</b>	MEO12	GNE60-XL-KRR-B	6	<b>60</b>	256	212	36	22	-2,5
<b>TME60-XL-N</b>	ME12	GE60-XL-KTT-B	4,04	<b>60</b>	195	160	29	16	1
<b>RME65-214-XL<sup>2)</sup></b>	ME14	GE65-214-XL-KRR-B	5,81	<b>65</b>	215	177	32	18	-
<b>TME65-214-XL<sup>2)</sup></b>	ME14	GE65-214-XL-KTT-B	5,81	<b>65</b>	215	177	32	18	-
<b>RME70-XL</b>	ME14	GE70-XL-KRR-B	5,55	<b>70</b>	215	177	32	18	-
<b>RMEO70-XL</b>	MEO14	GNE70-XL-KRR-B	9	<b>70</b>	300	252	43	25	-0,5
<b>TME70-XL</b>	ME14	GE70-XL-KTT-B	5,03	<b>70</b>	215	177	32	18	-
<b>RME75-XL</b>	ME15	GE75-XL-KRR-B	5,65	<b>75</b>	220	184	32	18	-
<b>TME75-XL</b>	ME15	GE75-XL-KTT-B	5,76	<b>75</b>	220	184	32	18	-
<b>RME80-XL</b>	ME16	GE80-XL-KRR-B	5,75	<b>80</b>	220	184	31	18	-2
<b>RMEO80-XL</b>	MEO16	GNE80-XL-KRR-B-FA107	12,7	<b>80</b>	275	235	51	12	3
<b>TME80-XL</b>	ME16	GE80-XL-KTT-B	5,51	<b>80</b>	220	184	31	18	-2
<b>RME90-XL</b>	ME18	GE90-XL-KRR-B	8,5	<b>90</b>	265	220	32	20	-4
<b>RMEO90-XL</b>	MEO18	GNE90-XL-KRR-B-FA107	12,7	<b>90</b>	300	260	50	22	3
<b>RME100-XL</b>	ME20	GE100-XL-KRR-B	11,45	<b>100</b>	295	245	36	22	-4
<b>RMEO100-XL</b>	MEO20	GNE100-XL-KRR-B-FA107	22,3	<b>100</b>	340	295	57	27	1,5
<b>RME120-XL</b>	ME24	GE120-XL-KRR-B	17,43	<b>120</b>	350	295	40	24	-4

<sup>1)</sup> To be ordered separately.  
 The caps are suitable for temperatures from -20 °C to +80 °C.

<sup>2)</sup> Alternative ball set 6214.



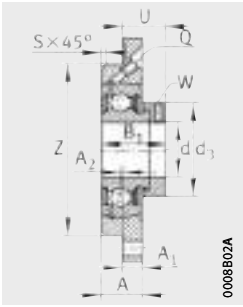

PME..-XL

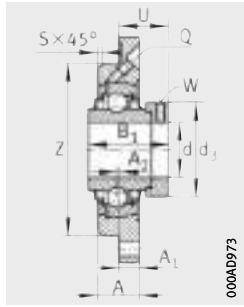

RME..-XL, RMEO..-XL  
(up to d = 70 mm)

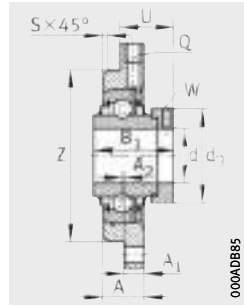

RMEO..-XL  
(from d = 80 mm)

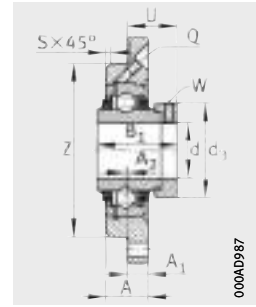

TME..-XL

N	B <sub>1</sub>	S	U	Z	Q	d <sub>3</sub>	W	Load carrying capacity Bearing			End cap <sup>1)</sup>
								Basic load ratings		Fatigue limit load C <sub>ur</sub>	
								dyn. C <sub>r</sub>	stat. C <sub>0r</sub>		
18	53,1	3	38,6	135	M6	84	5	56 000	36 000	1 820	KASK12
18	77,9	3	45,9	135	M6	84	5	56 000	36 000	1 820	KASK12
23	68	3	47,5	160	Rp <sup>1/8</sup>	89	5	87 000	52 000	2 650	–
18	77,9	3	45,9	135	M6	84	5	56 000	36 000	1 820	KASK12
18	66	6	44,5	150	Rp <sup>1/8</sup>	96	6	66 000	44 000	2 230	–
18	66	6	44,5	150	Rp <sup>1/8</sup>	96	6	66 000	44 000	2 230	–
18	66	6	44,5	150	Rp <sup>1/8</sup>	96	6	66 000	44 000	2 230	–
25	75,5	4	49,9	185	M6	102	6	111 000	68 000	3 300	–
18	66	6	44,5	150	Rp <sup>1/8</sup>	96	6	66 000	44 000	2 230	–
18	67	6	45,6	160	M6	100	6	66 000	44 500	2 240	–
18	67	6	45,6	160	M6	100	6	66 000	44 500	2 240	–
18	70,7	6	49,3	160	M6	108	6	76 000	54 000	2 600	–
22	93,6	6	56,6	200	Rp <sup>1/8</sup>	118	6	131 000	87 000	3 950	–
18	70,7	6	49,3	160	M6	108	6	76 000	54 000	2 600	–
23	69,5	3	50,5	190	Rp <sup>1/8</sup>	118	6	109 000	79 000	3 550	–
22	101	6	62,5	220	Rp <sup>1/8</sup>	132	6	151 000	107 000	4 600	–
23	75	3	53,4	210	M6	132	6	130 000	93 000	4 000	–
26	109,4	8	68,5	250	Rp <sup>1/8</sup>	145	6	184 000	141 000	5 700	–
27	81	3	56,5	250	M6	152	6	165 000	131 000	5 100	–



# Four-bolt flanged housing units

Flake graphite cast iron housing  
Round version  
With wide centring spigot  
Grub screws in inner ring

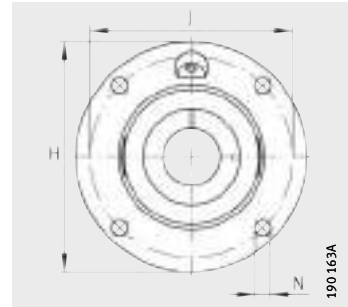

PMEY...XL, RMEY...XL



**Dimension table** - Dimensions in mm

Designation			Mass m ≈ kg	Dimensions					
Unit	Housing	Radial insert ball bearing		d	H	J	A	A <sub>1</sub>	A <sub>2</sub>
<b>PMEY20-XL-N</b>	ME04	GAY20-XL-NPP-B	0,5	<b>20</b>	100	78	17	8	2
<b>RMEY20-XL-N</b>	ME04	GYE20-XL-KRR-B	0,54	<b>20</b>	100	78	17	8	2
<b>PMEY25-XL-N</b>	ME05	GAY25-XL-NPP-B	0,7	<b>25</b>	115	90	19	9	2,5
<b>RMEY25-XL-N</b>	ME05	GYE25-XL-KRR-B	0,75	<b>25</b>	115	90	19	9	2,5
<b>PMEY30-XL-N</b>	ME06	GAY30-XL-NPP-B	0,9	<b>30</b>	125	100	20,5	9,5	2
<b>RMEY30-XL-N</b>	ME06	GYE30-XL-KRR-B	0,99	<b>30</b>	125	100	20,5	9,5	2
<b>PMEY35-XL-N</b>	ME07	GAY35-XL-NPP-B	1,15	<b>35</b>	135	110	20,5	10	1
<b>RMEY35-XL-N</b>	ME07	GYE35-XL-KRR-B	1,28	<b>35</b>	135	110	20,5	10	1
<b>PMEY40-XL-N</b>	ME08	GAY40-XL-NPP-B	1,51	<b>40</b>	145	120	23	11,5	1
<b>RMEY40-XL-N</b>	ME08	GYE40-XL-KRR-B	1,65	<b>40</b>	145	120	23	11,5	1
<b>PMEY45-XL</b>	ME09	GAY45-XL-NPP-B	1,77	<b>45</b>	155	130	25	12	2
<b>RMEY45-XL</b>	ME09	GYE45-XL-KRR-B	1,94	<b>45</b>	155	130	25	12	2
<b>PMEY50-XL-N</b>	ME10	GAY50-XL-NPP-B	2,03	<b>50</b>	165	135	25	13	1
<b>RMEY50-XL-N</b>	ME10	GYE50-XL-KRR-B	2,16	<b>50</b>	165	135	25	13	1
<b>RMEY55-XL</b>	ME11	GYE55-XL-KRR-B	3,05	<b>55</b>	185	150	27,5	15	-
<b>PMEY60-XL-N</b>	ME12	GAY60-XL-NPP-B	3,41	<b>60</b>	195	160	29	16	1
<b>RMEY60-XL-N</b>	ME12	GYE60-XL-KRR-B	3,71	<b>60</b>	195	160	29	16	1
<b>RMEY65-214-XL<sup>2)</sup></b>	ME14	GYE65-214-XL-KRR-B	5,35	<b>65</b>	215	177	32	18	-
<b>RMEY70-XL</b>	ME14	GYE70-XL-KRR-B	5,29	<b>70</b>	215	177	32	18	-
<b>RMEY75-XL</b>	ME15	GYE75-XL-KRR-B	5,19	<b>75</b>	220	184	32	18	-
<b>RMEY80-XL</b>	ME16	GYE80-XL-KRR-B	5,43	<b>80</b>	220	184	31	18	-2
<b>RMEY90-XL</b>	ME18	GYE90-XL-KRR-B	8,86	<b>90</b>	265	220	32	20	-4

1) To be ordered separately.  
The caps are suitable for temperatures from -20 °C to +80 °C.

2) Alternative ball set 6214.

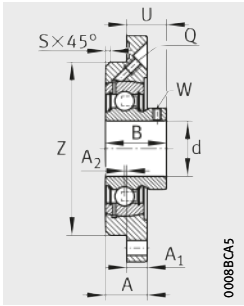

PMEY..-XL

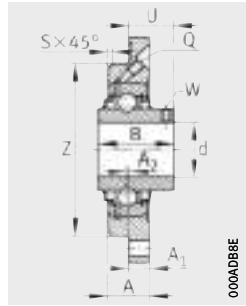

RMEY..-XL

N	B	S	U	Z	Q	W	Load carrying capacity Bearing			End cap <sup>1)</sup>
							Basic load ratings		Fatigue limit load C <sub>ur</sub> N	
							dyn. C <sub>r</sub> N	stat. C <sub>0r</sub> N		
9	25	2	16	62	M6	2,5	13 600	6 600	335	KASK04
9	31	2	16,3	62	M6	2,5	13 600	6 600	335	KASK04
9	27	2	17	70	M6	2,5	14 900	7 800	395	KASK05
9	34,1	2	17,3	70	M6	2,5	14 900	7 800	395	KASK05
11,5	30	2	19	80	M6	3	20 700	11 300	570	KASK06
11,5	38,1	2	20,2	80	M6	3	20 700	11 300	570	KASK06
11,5	35	2	24,45	90	M6	3	27 500	15 300	770	KASK07
11,5	42,9	2	24,4	90	M6	3	27 500	15 300	770	KASK07
11,5	39,5	2	28	100	M6	4	34 500	19 800	1 010	KASK08
11,5	49,2	2	29,2	100	M6	4	34 500	19 800	1 010	KASK08
14	41,5	2	28,5	105	M6	4	34 500	20 400	1 030	–
14	49,2	2	28,2	105	M6	4	34 500	20 400	1 030	–
14	43	3	31	110	M8×1	4	37 500	23 200	1 180	KASK10
14	51,6	3	31,6	110	M8×1	4	37 500	23 200	1 180	KASK10
18	55,6	3	33,4	125	M6	4	46 000	29 000	1 480	–
18	47	3	33	135	M6	5	56 000	36 000	1 820	KASK12
18	65,1	3	38,7	135	M6	5	56 000	36 000	1 820	KASK12
18	74,6	6	44,4	150	Rp <sup>1/8</sup>	5	66 000	44 000	2 230	–
18	74,6	6	44,4	150	Rp <sup>1/8</sup>	5	66 000	44 000	2 230	–
18	77,8	6	44,5	160	M6	5	66 000	44 500	2 240	–
18	82,6	6	51,3	160	M6	5	76 000	54 000	2 600	–
23	96	3	60,3	190	Rp <sup>1/8</sup>	6	109 000	79 000	3 550	–



# Four-bolt flanged housing units

Flake graphite cast iron housing  
 Round version  
 With narrow centring spigot

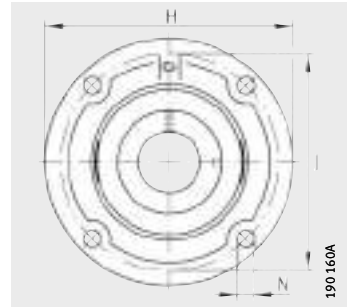

RFE...-XL, TFE...-XL



**Dimension table** - Dimensions in mm

Designation			Mass m ≈ kg	Dimensions						
Unit	Housing	Radial insert ball bearing		d	H	J	A	A <sub>1</sub>	A <sub>2</sub>	N
<b>RFE25-XL</b>	FE05	GE25-XL-KRR-B	0,8	<b>25</b>	115	92	22	9	9,5	9
<b>TFE25-XL</b>	FE05	GE25-XL-KTT-B	0,8	<b>25</b>	115	92	22	9	9,5	9
<b>RFE30-XL</b>	FE06	GE30-XL-KRR-B	1,08	<b>30</b>	127	105	22,5	9,5	10,5	9
<b>TFE30-XL</b>	FE06	GE30-XL-KTT-B	1,08	<b>30</b>	127	105	22,5	9,5	10,5	9
<b>RFE35-XL</b>	FE07	GE35-XL-KRR-B	1,33	<b>35</b>	135	110	22,5	10	9	11,5
<b>TFE35-XL</b>	FE07	GE35-XL-KTT-B	1,31	<b>35</b>	135	110	22,5	10	9	11,5
<b>RFE40-XL</b>	FE08	GE40-XL-KRR-B	1,72	<b>40</b>	145	120	26	11,5	11,5	11,5
<b>TFE40-XL</b>	FE08	GE40-XL-KTT-B	1,72	<b>40</b>	145	120	26	11,5	11,5	11,5
<b>RFE45-XL</b>	FE09	GE45-XL-KRR-B	2,06	<b>45</b>	155	130	26,5	12	11,5	14
<b>RFE50-XL-N<sup>1)</sup></b>	FE10	GE50-XL-KRR-B	2,48	<b>50</b>	165	136	27,5	13	12,5	14
<b>TFE50-XL-N<sup>1)</sup></b>	FE10	GE50-XL-KTT-B	2,48	<b>50</b>	165	136	27,5	13	12,5	14
<b>RFE60-XL</b>	FE12	GE60-XL-KRR-B	3,99	<b>60</b>	195	165	33	16	17	14
<b>TFE60-XL</b>	FE12	GE60-XL-KTT-B	3,99	<b>60</b>	195	165	33	16	17	14

<sup>1)</sup> End cap KASK10 must be ordered separately.  
 The cap is suitable for temperatures from -20 °C to +80 °C.

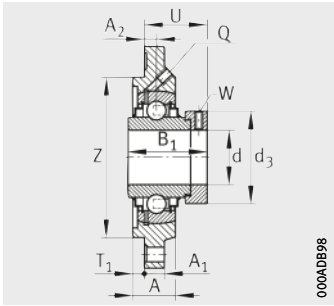

RFE..-XL

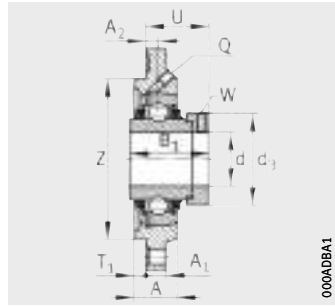

TFE..-XL

B <sub>1</sub>						Width across flats W	Load carrying capacity Bearing			End cap <sup>1)</sup>
							Basic load ratings		Fatigue limit load C <sub>ur</sub> N	
							dyn. C <sub>r</sub> N	stat. C <sub>0r</sub> N		
			h8		max.					
44,5	3	36,4	75	M6	37,5	3	14 900	7 800	395	–
44,5	3	36,4	75	M6	37,5	3	14 900	7 800	395	–
48,5	3	40,6	85	M6	44	4	20 700	11 300	570	–
48,5	3	40,6	85	M6	44	4	20 700	11 300	570	–
51,3	4	41,3	90	M6	55	5	27 500	15 300	770	–
51,3	4	41,3	90	M6	55	5	27 500	15 300	770	–
56,5	4	46,4	100	Rp <sup>1/8</sup>	58	5	34 500	19 800	1 010	–
56,5	4	46,4	100	Rp <sup>1/8</sup>	58	5	34 500	19 800	1 010	–
56,5	4	46,4	105	M6	63	5	34 500	20 400	1 030	–
62,8	4	50,6	115	Rp <sup>1/8</sup>	69	5	37 500	23 200	1 180	KASK10
62,8	4	50,6	115	Rp <sup>1/8</sup>	69	5	37 500	23 200	1 180	KASK10
77,9	4	63,8	140	Rp <sup>1/8</sup>	84	5	56 000	36 000	1 820	–
77,9	4	63,8	140	Rp <sup>1/8</sup>	84	5	56 000	36 000	1 820	–



# Four-bolt flanged housing units

Flake graphite cast iron housing  
With double row angular contact ball bearing

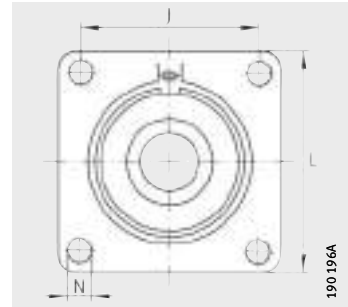

PCCJ

**Dimension table** - Dimensions in mm

Designation			Mass m ≈ kg	Dimensions					
Unit	Housing	Bearing <sup>1)</sup>		d	J	L	A	A <sub>1</sub>	A <sub>2</sub>
<b>PCCJ25</b>	CCJ05	G5205-2RS-N	0,79	<b>25</b>	70	95	22,1	12	11,7
<b>PCCJ30</b>	CCJ06	G5206-2RS-N	1,12	<b>30</b>	82,5	108	24	12	13
<b>PCCJ35</b>	CCJ07	G5207-2RS-N	1,48	<b>35</b>	92	118	26	14	14
<b>PCCJ40</b>	CCJ08	G5208-2RS-N	1,8	<b>40</b>	101,5	130	28	14	15

<sup>1)</sup> For general guidelines on double row angular contact ball bearings, see Catalogue HR 1, Rolling Bearings.

<sup>2)</sup> Tolerance class Normal of bearing outside diameter to ISO 492.

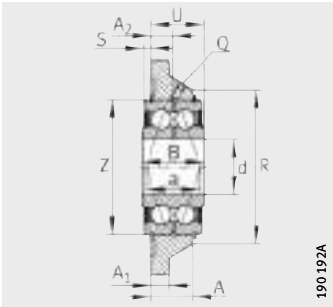

PCCJ

								Load carrying capacity Bearing		
								Basic load ratings		Fatigue limit load
a	N	B	R	S	U	Z <sup>2)</sup>	Q	dyn. C <sub>r</sub> N	stat. C <sub>0r</sub> N	C <sub>ur</sub> N
			max.			h5				
24	11,5	30	64	2,4	26,7	52	M6	21 600	14 900	750
28,9	11,5	34	76	3,2	29,7	62	M6	30 000	21 400	1 080
33,8	14	36	88	3	31,7	72	M6	39 500	29 000	1 470
38,8	14	38	98	3,2	33,7	80	M6	50 000	38 000	1 910



# Take-up housing units

- Flake graphite cast iron housing
- Guide slots on both sides
- Hole for threaded rod
- Eccentric locking collar

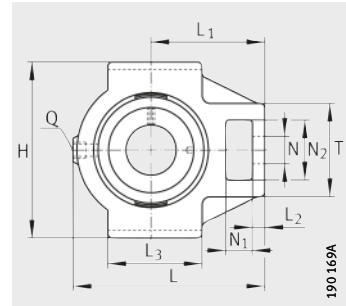

PTUE...XL, RTUE...XL, TTUE...XL



**Dimension table** - Dimensions in mm

Designation			Mass m ≈ kg	Dimensions								
Unit	Housing	Radial insert ball bearing		d	H	L	L <sub>1</sub>	L <sub>2</sub>	L <sub>3</sub>	A	A <sub>1</sub> H13	A <sub>2</sub>
<b>PTUE20-XL</b>	TUE04	GRAE20-XL-NPP-B	0,83	<b>20</b>	90	94,5	60	9	50	37	12	25
<b>RTUE20-XL</b>	TUE04	GE20-XL-KRR-B	0,9	<b>20</b>	90	94,5	60	9	50	37	12	25
<b>PTUE25-XL</b>	TUE05	GRAE25-XL-NPP-B	0,85	<b>25</b>	90	98,5	62	10	50	37	12	25
<b>RTUE25-XL</b>	TUE05	GE25-XL-KRR-B	0,91	<b>25</b>	90	98,5	62	10	50	37	12	25
<b>TTUE25-XL</b>	TUE05	GE25-XL-KTT-B	0,91	<b>25</b>	90	98,5	62	10	50	37	12	25
<b>PTUE30-XL</b>	TUE06	GRAE30-XL-NPP-B	1,19	<b>30</b>	102	114,5	70	10	57	37	12	25
<b>RTUE30-XL</b>	TUE06	GE30-XL-KRR-B	1,24	<b>30</b>	102	114,5	70	10	57	37	12	25
<b>TTUE30-XL</b>	TUE06	GE30-XL-KTT-B	1,25	<b>30</b>	102	114,5	70	10	57	37	12	25
<b>PTUE35-XL</b>	TUE07	GRAE35-XL-NPP-B	1,69	<b>35</b>	102	131,5	80	13	63	40	12	30
<b>RTUE35-XL</b>	TUE07	GE35-XL-KRR-B	1,77	<b>35</b>	102	131,5	80	13	63	40	12	30
<b>TTUE35-XL</b>	TUE07	GE35-XL-KTT-B	1,75	<b>35</b>	102	131,5	80	13	63	40	12	30
<b>PTUE40-XL</b>	TUE08	GRAE40-XL-NPP-B	2,43	<b>40</b>	115	141	88	16	82	50	16	35
<b>RTUE40-XL</b>	TUE08	GE40-XL-KRR-B	2,52	<b>40</b>	115	141	88	16	82	50	16	35
<b>TTUE40-XL</b>	TUE08	GE40-XL-KTT-B	2,55	<b>40</b>	115	141	88	16	82	50	16	35
<b>PTUE45-XL</b>	TUE09	GRAE45-XL-NPP-B	2,32	<b>45</b>	115	141	88	16	82	50	16	35
<b>RTUE45-XL</b>	TUE09	GE45-XL-KRR-B	2,61	<b>45</b>	115	141	88	16	82	50	16	35
<b>TTUE45-XL</b>	TUE09	GE45-XL-KTT-B	2,45	<b>45</b>	115	141	88	16	82	50	16	35
<b>PTUE50-XL</b>	TUE10	GRAE50-XL-NPP-B	2,42	<b>50</b>	115	148	90	16	85	50	16	35
<b>RTUE50-XL</b>	TUE10	GE50-XL-KRR-B	2,57	<b>50</b>	115	148	90	16	85	50	16	35
<b>TTUE50-XL</b>	TUE10	GE50-XL-KTT-B	2,56	<b>50</b>	115	148	90	16	85	50	16	35
<b>PTUE55-XL</b>	TUE11	GRAE55-XL-NPP-B	3,99	<b>55</b>	145	169	104	17	95	60	22	42
<b>RTUE55-XL</b>	TUE11	GE55-XL-KRR-B	4,6	<b>55</b>	145	169	104	17	95	60	22	42
<b>TTUE55-XL</b>	TUE11	GE55-XL-KTT-B	4,72	<b>55</b>	145	169	104	17	95	60	22	42



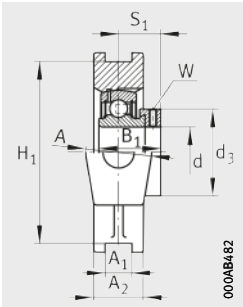

PTUE...XL

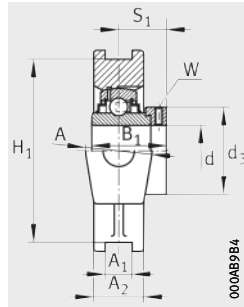

RTUE...XL

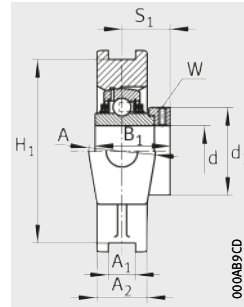

TTUE...XL

										Width across flats W	Load carrying capacity Bearing		
											Basic load ratings		Fatigue limit load C <sub>ur</sub> N
H <sub>1</sub> ±0,15	N	N <sub>1</sub>	N <sub>2</sub>	B <sub>1</sub>	S <sub>1</sub>	T	Q	d <sub>3</sub> max.	dyn. C <sub>r</sub> N		stat. C <sub>0r</sub> N		
76	19	18	32	31	23,5	51	Rp <sup>1/8</sup>	33	3	13 600	6 600	335	
76	19	18	32	43,7	26,6	51	Rp <sup>1/8</sup>	33	3	13 600	6 600	335	
76	19	18	32	31	23,5	51	M6	37,5	3	14 900	7 800	395	
76	19	18	32	44,5	27	51	M6	37,5	3	14 900	7 800	395	
76	19	18	32	44,5	27	51	M6	37,5	3	14 900	7 800	395	
89	22	18	36,5	35,8	26,8	56	Rp <sup>1/8</sup>	44	4	20 700	11 300	570	
89	22	18	36,5	48,5	30,2	56	Rp <sup>1/8</sup>	44	4	20 700	11 300	570	
89	22	18	36,5	48,5	30,2	56	Rp <sup>1/8</sup>	44	4	20 700	11 300	570	
89	22	18	36,5	39	29,5	64	M6	55	5	27 500	15 300	770	
89	22	18	36,5	51,3	32,5	64	M6	55	5	27 500	15 300	770	
89	22	18	36,5	51,3	32,5	64	M6	55	5	27 500	15 300	770	
102	29	20	49	43,8	32,8	82	Rp <sup>1/8</sup>	58	5	34 500	19 800	1 010	
102	29	20	49	56,5	35,1	82	Rp <sup>1/8</sup>	58	5	34 500	19 800	1 010	
102	29	20	49	56,5	35,1	82	Rp <sup>1/8</sup>	58	5	34 500	19 800	1 010	
102	29	20	49	43,8	32,8	82	M6	63	5	34 500	20 400	1 030	
102	29	20	49	56,5	35,1	82	M6	63	5	34 500	20 400	1 030	
102	29	20	49	56,5	35,1	82	M6	63	5	34 500	20 400	1 030	
102	29	20	49	43,8	32,8	83	Rp <sup>1/8</sup>	69	5	37 500	23 200	1 180	
102	29	20	49	62,8	38,2	83	Rp <sup>1/8</sup>	69	5	37 500	23 200	1 180	
102	29	20	49	62,8	38,2	83	Rp <sup>1/8</sup>	69	5	37 500	23 200	1 180	
130	35	26	63,5	48,4	36,4	102	M6	76	5	46 000	29 000	1 480	
130	35	26	63,5	71,4	43,6	102	M6	76	5	46 000	29 000	1 480	
130	35	26	63,5	71,4	43,6	102	M6	76	5	46 000	29 000	1 480	



# Take-up housing units

- Flake graphite cast iron housing
- Guide slots on both sides
- Hole for threaded rod
- Eccentric locking collar

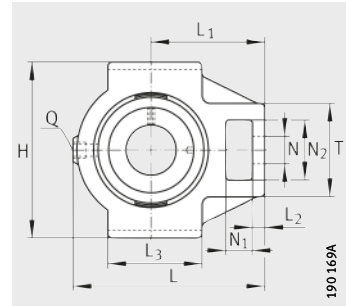

PTUE...XL, RTUE...XL, TTUE...XL,  
RTUEO...XL



**Dimension table** (continued) · Dimensions in mm

Designation			Mass	Dimensions								
Unit	Housing	Radial insert ball bearing		m ≈ kg	d	H	L	L <sub>1</sub>	L <sub>2</sub>	L <sub>3</sub>	A	A <sub>1</sub> H13
<b>PTUE60-XL</b>	TUE12	GRAE60-XL-NPP-B	4,21	<b>60</b>	146	186	118	19	100	60	22	44
<b>RTUE60-XL</b>	TUE12	GE60-XL-KRR-B	4,77	<b>60</b>	146	186	118	19	100	60	22	44
<b>TTUE60-XL</b>	TUE12	GE60-XL-KTT-B	4,76	<b>60</b>	146	186	118	19	100	60	22	44
<b>RTUE65-214-XL<sup>1)</sup></b>	TUE13/14	GE65-214-XL-KRR-B	7,46	<b>65</b>	166	214	135	20	120	70	25	50
<b>RTUE70-XL</b>	TUE13/14	GE70-XL-KRR-B	6,82	<b>70</b>	166	214	135	20	120	70	25	50
<b>TTUE70-XL</b>	TUE13/14	GE70-XL-KTT-B	6,85	<b>70</b>	166	214	135	20	120	70	25	50
<b>RTUE75-XL</b>	TUE15	GE75-XL-KRR-B	6,44	<b>75</b>	166	214	135	20	120	70	25	50
<b>TTUE75-XL</b>	TUE15	GE75-XL-KTT-B	7,13	<b>75</b>	166	214	135	20	120	70	25	50
<b>RTUE80-XL</b>	TUE16	GE80-XL-KRR-B	8,4	<b>80</b>	184	230	140	20	120	70	28	50
<b>RTUEO80-XL</b>	TUEO16	GNE80-XL-KRR-B	17,25	<b>80</b>	230	282	174	28	150	102	30	60
<b>TTUE80-XL</b>	TUE16	GE80-XL-KTT-B	7,7	<b>80</b>	184	230	140	20	120	70	28	50
<b>RTUE90-XL</b>	TUE18	GE90-XL-KRR-B	11,87	<b>90</b>	215	275	170	30	140	80	28	55
<b>RTUEO90-XL</b>	TUEO18	GNE90-XL-KRR-B	22,9	<b>90</b>	255	312	192	30	165	110	32	66
<b>RTUE100-XL</b>	TUE20	GE100-XL-KRR-B	14,55	<b>100</b>	240	295	180	30	160	90	28	60
<b>RTUE120-XL</b>	TUE24	GE120-XL-KRR-B	23,89	<b>120</b>	285	345	210	35	190	100	32	70

<sup>1)</sup> Alternative ball set 6214.

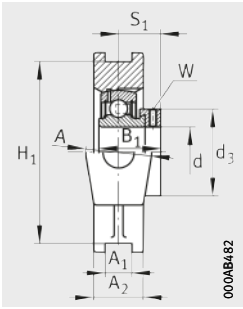

PTUE...XL

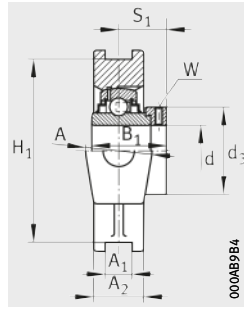

RTUE...XL, RTUEO...XL

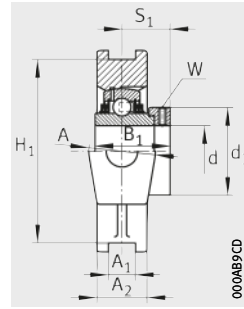

TTUE...XL

										Width across flats W	Load carrying capacity Bearing		
											Basic load ratings		Fatigue limit load $C_{ur}$ N
$H_1$	N	$N_1$	$N_2$	$B_1$	$S_1$	T	Q	$d_3$ max.	dyn. $C_r$ N		stat. $C_{Or}$ N		
130 <sup>+0,15</sup> <sub>-0,15</sub>	35	32	63,5	53,1	39,6	102	M6	84	5	56 000	36 000	1 820	
130 <sup>+0,15</sup> <sub>-0,15</sub>	35	32	63,5	77,9	46,9	102	M6	84	5	56 000	36 000	1 820	
130 <sup>+0,15</sup> <sub>-0,15</sub>	35	32	63,5	77,9	46,9	102	M6	84	5	56 000	36 000	1 820	
151 <sup>+0,25</sup> <sub>-0,25</sub>	41	35	70	66	44,5	110	M6	96	6	66 000	44 000	2 230	
151 <sup>+0,25</sup> <sub>-0,25</sub>	41	35	70	66	44,5	110	M6	96	6	66 000	44 000	2 230	
151 <sup>+0,25</sup> <sub>-0,25</sub>	41	35	70	66	44,5	110	M6	96	6	66 000	44 000	2 230	
151 <sup>+0,25</sup> <sub>-0,25</sub>	41	35	70	67	45,5	110	M6	100	6	66 000	44 500	2 240	
151 <sup>+0,25</sup> <sub>-0,25</sub>	41	35	70	67	45,5	110	M6	100	6	66 000	44 500	2 240	
165 <sup>+0,25</sup> <sub>-0,25</sub>	41	35	70	70,7	47,3	110	M6	108	6	76 000	54 000	2 600	
204 <sup>0</sup> <sub>-0,6</sub>	53	42	98	93,6	59,6	150	M6	118	6	131 000	87 000	3 950	
165 <sup>+0,25</sup> <sub>-0,25</sub>	41	35	70	70,7	47,3	110	M6	108	6	76 000	54 000	2 600	
190 <sup>+0,25</sup> <sub>-0,25</sub>	47	40	80	69,5	46,5	130	Rp <sup>1/8</sup>	118	6	109 000	79 000	3 550	
228 <sup>0</sup> <sub>-0,6</sub>	57	46	106	101	65,5	160	M6	132	6	151 000	107 000	4 600	
215 <sup>+0,25</sup> <sub>-0,25</sub>	47	40	80	75	49,5	130	M6	132	6	130 000	93 000	4 000	
255 <sup>+0,25</sup> <sub>-0,25</sub>	55	45	95	81	52,5	150	Rp <sup>1/8</sup>	152	6	165 000	131 000	5 100	



# Take-up housing units

- Flake graphite cast iron housing
- Guide slots on both sides
- Hole for threaded rod
- Grub screws in inner ring

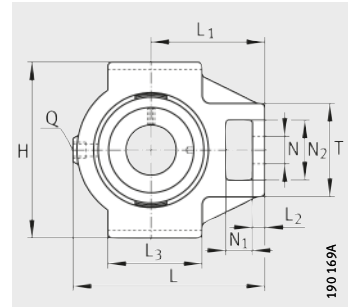

PTUEY..-XL, RTUEY..-XL

**Dimension table** - Dimensions in mm

Designation			Mass m ≈ kg	Dimensions							
Unit	Housing	Radial insert ball bearing		d	H	L	L <sub>1</sub>	L <sub>2</sub>	L <sub>3</sub>	A	A <sub>1</sub> H13
<b>PTUEY20-XL</b>	TUE04	GAY20-XL-NPP-B	0,8	<b>20</b>	90	94,5	60	9	50	37	12
<b>RTUEY20-XL</b>	TUE04	GYE20-XL-KRR-B	0,84	<b>20</b>	90	94,5	60	9	50	37	12
<b>PTUEY25-XL</b>	TUE05	GAY25-XL-NPP-B	0,82	<b>25</b>	90	98,5	62	10	50	37	12
<b>RTUEY25-XL</b>	TUE05	GYE25-XL-KRR-B	0,86	<b>25</b>	90	98,5	62	10	50	37	12
<b>PTUEY30-XL</b>	TUE06	GAY30-XL-NPP-B	1,11	<b>30</b>	102	114,5	70	10	57	37	12
<b>RTUEY30-XL</b>	TUE06	GYE30-XL-KRR-B	1,19	<b>30</b>	102	114,5	70	10	57	37	12
<b>PTUEY35-XL</b>	TUE07	GAY35-XL-NPP-B	1,64	<b>35</b>	102	131,5	80	13	63	40	12
<b>RTUEY35-XL</b>	TUE07	GYE35-XL-KRR-B	1,74	<b>35</b>	102	131,5	80	13	63	40	12
<b>RTUEY40-XL</b>	TUE08	GYE40-XL-KRR-B	2,43	<b>40</b>	115	141	88	16	82	50	16
<b>PTUEY50-XL</b>	TUE10	GAY50-XL-NPP-B	2,25	<b>50</b>	115	148	90	16	85	50	16
<b>RTUEY50-XL</b>	TUE10	GYE50-XL-KRR-B	2,38	<b>50</b>	115	148	90	16	85	50	16
<b>PTUEY60-XL</b>	TUE12	GAY60-XL-NPP-B	4,14	<b>60</b>	146	186	118	19	100	60	22
<b>RTUEY60-XL</b>	TUE12	GYE60-XL-KRR-B	4,44	<b>60</b>	146	186	118	19	100	60	22
<b>RTUEY65-214-XL<sup>1)</sup></b>	TUE13/14	GYE65-214-XL-KRR-B	7	<b>65</b>	166	214	135	20	120	70	25
<b>RTUEY70-XL</b>	TUE13/14	GYE70-XL-KRR-B	6,69	<b>70</b>	166	214	135	20	120	70	25
<b>RTUEY75-XL</b>	TUE15	GYE75-XL-KRR-B	6,38	<b>75</b>	166	214	135	20	120	70	25
<b>RTUEY80-XL</b>	TUE16	GYE80-XL-KRR-B	7,63	<b>80</b>	184	230	140	20	120	70	28

<sup>1)</sup> Alternative ball set 6214.

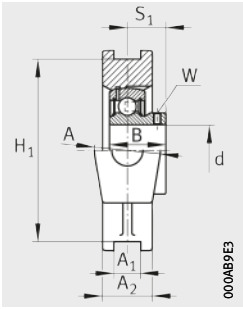

PTUEY..-XL

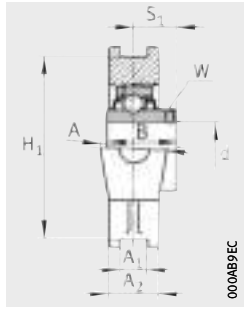

RTUEY..-XL

										Width across flats W	Load carrying capacity Bearing		
											Basic load ratings		Fatigue limit load C <sub>ur</sub> N
A <sub>2</sub>	H <sub>1</sub>	N	N <sub>1</sub>	N <sub>2</sub>	B	S <sub>1</sub>	T	Q	dyn. C <sub>r</sub> N		stat. C <sub>0r</sub> N		
25	76 <sup>+0,15</sup> <sub>-0,15</sub>	19	18	32	25	18	51	Rp <sup>1/8</sup>	2,5	13 600	6 600	335	
25	76 <sup>+0,15</sup> <sub>-0,15</sub>	19	18	32	31	18,3	51	Rp <sup>1/8</sup>	2,5	13 600	6 600	335	
25	76 <sup>+0,15</sup> <sub>-0,15</sub>	19	18	32	27	19,5	51	M6	2,5	14 900	7 800	395	
25	76 <sup>+0,15</sup> <sub>-0,15</sub>	19	18	32	34,1	19,8	51	M6	2,5	14 900	7 800	395	
25	89 <sup>+0,15</sup> <sub>-0,15</sub>	22	18	36,5	30	21	56	Rp <sup>1/8</sup>	3	20 700	11 300	570	
25	89 <sup>+0,15</sup> <sub>-0,15</sub>	22	18	36,5	38,1	22,2	56	Rp <sup>1/8</sup>	3	20 700	11 300	570	
30	89 <sup>+0,15</sup> <sub>-0,15</sub>	22	18	36,5	35	25,5	64	M6	3	27 500	15 300	770	
30	89 <sup>+0,15</sup> <sub>-0,15</sub>	22	18	36,5	42,9	25,4	64	M6	3	27 500	15 300	770	
35	102 <sup>+0,15</sup> <sub>-0,15</sub>	29	20	49	49,2	30,2	82	Rp <sup>1/8</sup>	4	34 500	19 800	1 010	
35	102 <sup>+0,15</sup> <sub>-0,15</sub>	29	20	49	43	32	83	Rp <sup>1/8</sup>	4	37 500	23 200	1 180	
35	102 <sup>+0,15</sup> <sub>-0,15</sub>	29	20	49	51,6	32,6	83	Rp <sup>1/8</sup>	4	37 500	23 200	1 180	
44	130 <sup>+0,15</sup> <sub>-0,15</sub>	35	32	63,5	47	34	102	M6	5	56 000	36 000	1 820	
44	130 <sup>+0,15</sup> <sub>-0,15</sub>	35	32	63,5	65,1	39,7	102	M6	5	56 000	36 000	1 820	
50	151 <sup>+0,25</sup> <sub>-0,25</sub>	41	35	70	74,6	44,4	110	M6	5	66 000	44 000	2 230	
50	151 <sup>+0,25</sup> <sub>-0,25</sub>	41	35	70	74,6	44,4	110	M6	5	66 000	44 000	2 230	
50	151 <sup>+0,25</sup> <sub>-0,25</sub>	41	35	70	77,8	44,5	110	M6	5	66 000	44 500	2 240	
50	165 <sup>+0,25</sup> <sub>-0,25</sub>	41	35	70	82,6	49,3	110	M6	5	76 000	54 000	2 600	



# Take-up housing units

Flake graphite cast iron housing  
Guide surfaces on both sides  
With threaded hole

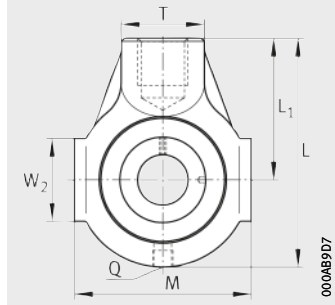

PHE...XL, RHE...XL, THE...XL, PHEY...XL

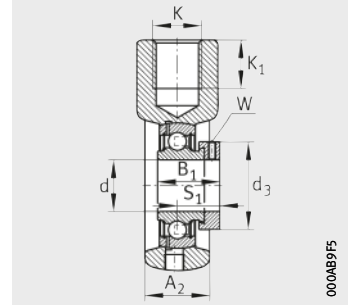

PHE...XL

**Dimension table** - Dimensions in mm

Designation			Mass m ≈ kg	Dimensions					
Unit	Housing	Radial insert ball bearing		d	L	L <sub>1</sub>	A <sub>2</sub>	K	K <sub>1</sub>
<b>PHE20-XL</b>	HE04	GRAE20-XL-NPP-B	0,54	<b>20</b>	91	58	25	M16	21
<b>RHE20-XL</b>	HE04	GE20-XL-KRR-B	0,58	<b>20</b>	91	58	25	M16	21
<b>PHE25-XL</b>	HE05	GRAE25-XL-NPP-B	0,71	<b>25</b>	99	64	28	M20	22
<b>RHE25-XL</b>	HE05	GE25-XL-KRR-B	0,77	<b>25</b>	99	64	28	M20	22
<b>THE25-XL</b>	HE05	GE25-XL-KTT-B	0,75	<b>25</b>	99	64	28	M20	22
<b>PHE30-XL</b>	HE06	GRAE30-XL-NPP-B	1,09	<b>30</b>	114	72	32	M24	24
<b>RHE30-XL</b>	HE06	GE30-XL-KRR-B	1,16	<b>30</b>	114	72	32	M24	24
<b>THE30-XL</b>	HE06	GE30-XL-KTT-B	1,17	<b>30</b>	114	72	32	M24	24
<b>PHE35-XL</b>	HE07	GRAE35-XL-NPP-B	1,32	<b>35</b>	122	76	32	M24	24
<b>RHE35-XL</b>	HE07	GE35-XL-KRR-B	1,39	<b>35</b>	122	76	32	M24	24
<b>THE35-XL</b>	HE07	GE35-XL-KTT-B	1,36	<b>35</b>	122	76	32	M24	24
<b>PHE40-XL</b>	HE08	GRAE40-XL-NPP-B	1,65	<b>40</b>	135	85	36	M24	24
<b>RHE40-XL</b>	HE08	GE40-XL-KRR-B	1,77	<b>40</b>	135	85	36	M24	24
<b>THE40-XL</b>	HE08	GE40-XL-KTT-B	1,8	<b>40</b>	135	85	36	M24	24
<b>PHE45-XL</b>	HE09	GRAE45-XL-NPP-B	1,89	<b>45</b>	145	90	40	M24	24
<b>RHE45-XL</b>	HE09	GE45-XL-KRR-B	2,01	<b>45</b>	145	90	40	M24	24
<b>THE45-XL</b>	HE09	GE45-XL-KTT-B	2,13	<b>45</b>	145	90	40	M24	24
<b>PHE50-XL</b>	HE10	GRAE50-XL-NPP-B	1,92	<b>50</b>	145	90	40	M24	24
<b>RHE50-XL</b>	HE10	GE50-XL-KRR-B	2,15	<b>50</b>	145	90	40	M24	24
<b>THE50-XL</b>	HE10	GE50-XL-KTT-B	2,08	<b>50</b>	145	90	40	M24	24

**Dimension table** - Dimensions in mm

Designation			Mass m ≈ kg	Dimensions					
Unit	Housing	Radial insert ball bearing		d	L	L <sub>1</sub>	A <sub>2</sub>	K	K <sub>1</sub>
<b>PHEY20-XL</b>	HE04	GAY20-XL-NPP-B	0,51	<b>20</b>	91	58	25	M16	21
<b>PHEY25-XL</b>	HE05	GAY25-XL-NPP-B	0,68	<b>25</b>	99	64	28	M20	22
<b>PHEY30-XL</b>	HE06	GAY30-XL-NPP-B	1,03	<b>30</b>	114	72	32	M24	24
<b>PHEY35-XL</b>	HE07	GAY35-XL-NPP-B	1,23	<b>35</b>	122	76	32	M24	24
<b>PHEY40-XL</b>	HE08	GAY40-XL-NPP-B	1,5	<b>40</b>	135	85	36	M24	24
<b>PHEY45-XL</b>	HE09	GAY45-XL-NPP-B	1,91	<b>45</b>	145	90	40	M24	24

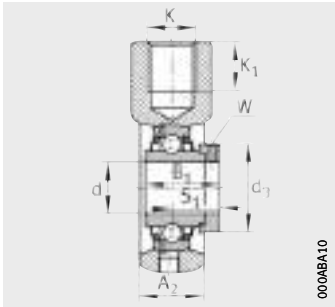

RHE..-XL

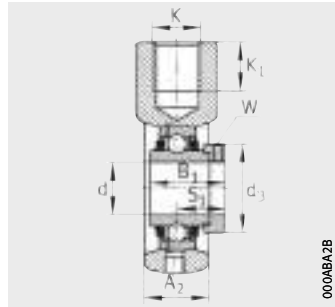

THE..-XL

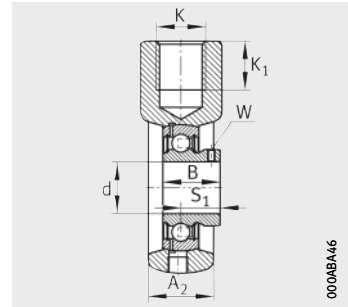

PHEY..-XL

B <sub>1</sub>	M	S <sub>1</sub>	T	W <sub>2</sub>	Q	d <sub>3</sub> max.	Width across flats W	Load carrying capacity Bearing		
								Basic load ratings		Fatigue limit load C <sub>ur</sub> N
								dyn. C <sub>r</sub> N	stat. C <sub>0r</sub> N	
31	65	23,5	30	38	M6	33	3	13 600	6 600	335
43,7	65	26,6	30	38	M6	33	3	13 600	6 600	335
31	70	23,5	35	38	M6	37,5	3	14 900	7 800	395
44,5	70	27	35	38	M6	37,5	3	14 900	7 800	395
44,5	70	27	35	38	M6	37,5	3	14 900	7 800	395
35,8	85	26,8	40	40	Rp <sup>1/8</sup>	44	4	20 700	11 300	570
48,5	85	30,2	40	40	Rp <sup>1/8</sup>	44	4	20 700	11 300	570
48,5	85	30,2	40	40	Rp <sup>1/8</sup>	44	4	20 700	11 300	570
39	90	29,5	40	49	M6	55	5	27 500	15 300	770
51,3	90	32,5	40	49	M6	55	5	27 500	15 300	770
51,3	90	32,5	40	49	M6	55	5	27 500	15 300	770
43,8	100	32,8	40	45	M6	58	5	34 500	19 800	1 010
56,5	100	35,1	40	45	M6	58	5	34 500	19 800	1 010
56,5	100	35,1	40	45	M6	58	5	34 500	19 800	1 010
43,8	110	32,8	40	45	M6	63	5	34 500	20 400	1 030
56,5	110	35,1	40	45	M6	63	5	34 500	20 400	1 030
56,5	110	35,1	40	45	M6	63	5	34 500	20 400	1 030
43,8	110	32,8	40	46	M6	69	5	37 500	23 200	1 180
62,8	110	38,2	40	46	M6	69	5	37 500	23 200	1 180
62,8	110	38,2	40	46	M6	69	5	37 500	23 200	1 180

B	M	S <sub>1</sub>	T	W <sub>2</sub>	Q	Width across flats W	Load carrying capacity Bearing		
							Basic load ratings		Fatigue limit load C <sub>ur</sub> N
							dyn. C <sub>r</sub> N	stat. C <sub>0r</sub> N	
25	65	18	30	38	M6	2,5	13 600	6 600	335
27	70	19,5	35	38	M6	2,5	14 900	7 800	395
30	85	21	40	40	Rp <sup>1/8</sup>	3	20 700	11 300	570
35	90	25,5	40	49	M6	3	27 500	15 300	770
39,5	100	29	40	45	M6	4	34 500	19 800	1 010
41,5	110	30,5	40	45	M6	4	34 500	20 400	1 030



# Take-up housing units

Flake graphite  
cast iron housing  
Guide tube  
With adjusting screw

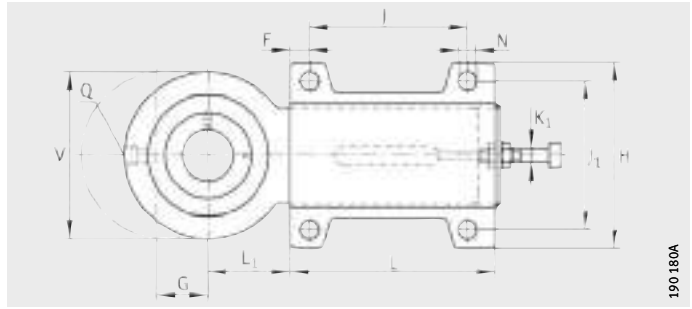

PHUSE...XL(-N)

**Dimension table** - Dimensions in mm

Designation				Mass m ≈ kg	Dimensions									
Unit	Housing	Guide tube	Radial insert ball bearing		d	H	J	J <sub>1</sub>	L	L <sub>1</sub>	A	A <sub>2</sub>	H <sub>1</sub>	N
<b>PHUSE25-XL</b>	HUE05	HUSE07	GRAE25-XL-NPP-B	2,07	<b>25</b>	103	140	80	187	50	28	22	52	11,5
<b>PHUSE30-XL</b>	HUE06	HUSE07	GRAE30-XL-NPP-B	2,22	<b>30</b>	103	140	80	187	50	28	22	52	11,5
<b>PHUSE35-XL</b>	HUE07	HUSE07	GRAE35-XL-NPP-B	2,46	<b>35</b>	103	140	80	187	50	28	22	52	11,5
<b>PHUSE40-XL</b>	HUE08	HUSE10	GRAE40-XL-NPP-B	4,89	<b>40</b>	130	180	100	256	60	36	30	60	14
<b>PHUSE50-XL-N</b>	HUE10	HUSE10	GRAE50-XL-NPP-B	5,25	<b>50</b>	130	180	100	256	60	36	30	60	14

1) End cap KASK10 must be ordered separately.  
The cap is suitable for temperatures from -20 °C to +80 °C.



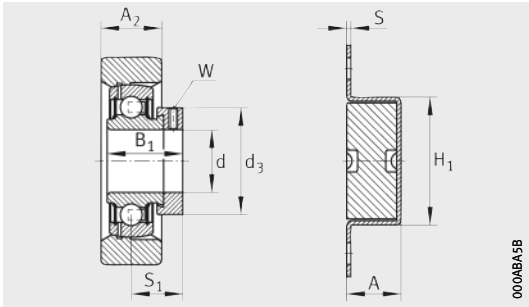

PHUSE..XL(-N)

										Load carrying capacity				End cap <sup>1)</sup>		
										Width across flats			Bearing		Housing	
													Basic load ratings			Fatigue limit load
B <sub>1</sub>	K <sub>1</sub>	S	F	G	S <sub>1</sub>	V	Q	d <sub>3</sub>	W	dyn. C <sub>r</sub> N	stat. C <sub>0r</sub> N	C <sub>ur</sub> N	C <sub>0rG</sub> N			
31	M12	4	20	65	23,5	78	M6	37,5	3	14 900	7 800	395	7 800	–		
35,8	M12	4	20	65	26,8	88	M6	44	4	20 700	11 300	570	11 300	–		
39	M12	4	20	65	29,5	98	Rp <sup>1/8</sup>	55	5	27 500	15 300	770	15 300	–		
43,8	M16	4	20	80	32,8	108	M6	58	5	34 500	19 800	1 010	19 800	–		
43,8	M16	4	20	80	32,8	120	M6	69	5	37 500	23 200	1 180	23 200	KASK10		



# Take-up housing units

Flake graphite cast iron housing  
Self-aligning

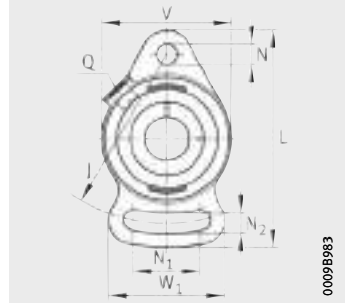

PSFT..-XL



**Dimension table** - Dimensions in mm

Designation			Mass m ≈ kg	Dimensions						
Unit	Housing	Radial insert ball bearing		d	J	L	A	A <sub>1</sub>	A <sub>2</sub>	N
<b>PSFT20-XL</b>	SFT04	GRAE20-XL-NPP-B	0,41	<b>20</b>	90	112	18	10	10,5	11,5
<b>PSFT25-XL</b>	SFT05	GRAE25-XL-NPP-B	0,52	<b>25</b>	99	124	20	11	12,5	11,5
<b>PSFT30-XL</b>	SFT06	GRAE30-XL-NPP-B	0,77	<b>30</b>	117	142	22	12	13	11,5
<b>PSFT35-XL</b>	SFT07	GRAE35-XL-NPP-B	1,1	<b>35</b>	128	155	25	12,5	15	14

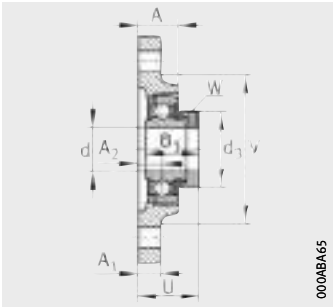

PSFT..XL

								Width across flats W	Load carrying capacity Housing		
									Basic load ratings		Fatigue limit load
N <sub>1</sub>	N <sub>2</sub>	B <sub>1</sub>	U	V	W <sub>1</sub>	Q	d <sub>3</sub> max.	dyn. C <sub>r</sub> N	stat. C <sub>0r</sub> N	C <sub>ur</sub> N	
30	11,5	31	34	61	52	M6	33	13 600	6 600	335	
37,5	11,5	31	36	70	63	M6	37,5	14 900	7 800	395	
40	11,5	35,8	39,7	80	65	M6	44	20 700	11 300	570	
45	14	39	44,5	90	75	M6	55	27 500	15 300	770	





## Housing units with sheet steel housing

Plummer block housing units

Flanged housing units

Take-up housing units

# Housing units with sheet steel housing

	Page
<b>Product overview</b>	Housing units with sheet steel housing..... 308
<b>Matrix</b>	Possible combinations Radial insert ball bearings with sheet steel housings..... 310
<b>Features</b>	X-life ..... 312 Plummer block and flanged housing units..... 313 Plummer block and flanged housing units with rubber interliner..... 313 Take-up housing units ..... 314 Operating temperature ..... 314 Lubrication ..... 314 Corrosion-resistant units ..... 314 Market sectors..... 314 Suffixes..... 314
<b>Design and safety guidelines</b>	Compensation of static misalignments..... 315 Speed limits for radial insert ball bearings ..... 316 Load carrying capacity of housings ..... 316 Design of adjacent construction..... 317
<b>Accuracy</b>	Dimensional tolerances ..... 317
<b>Dimension tables</b>	Plummer block housing units, with or without rubber interliner..... 318 Two-bolt flanged housing units ..... 322 Two-bolt flanged housing units, with rubber interliner ..... 324 Three-bolt flanged housing units..... 326 Three-bolt and four-bolt flanged housing units ..... 328 Take-up housing units ..... 332



# Product overview Housing units with sheet steel housing

## Plummer block housing units

PBS..-XL

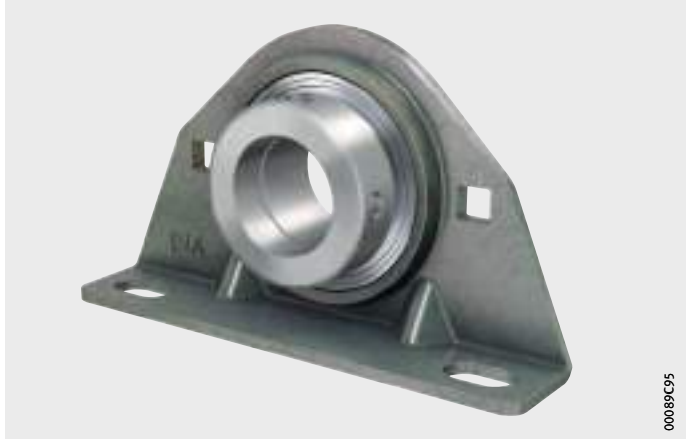

00089C95

PB..-XL, PBY..-XL, RPB..-XL



00089C77

**Two-bolt and three-bolt flanged housing units**

RAT..-XL, RATY..-XL, RALT..-XL, PCSLT..-XL



00089C7F

RCSMF..-XL



00089C89

RATR..-XL, RALTR..-XL,  
RRTR..-XL, RATRY..-XL



00089C83

RA..-XL, RAY..-XL, GRA..-XL



00089C7B







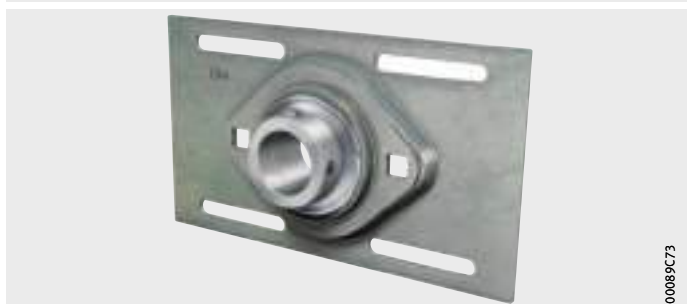



**Take-up housing units**

MSTU..-XL



00089C73

Possible combinations Radial insert ball bearings with sheet steel housings	Housing <sup>1)</sup>				
	Plummer block housing			Two-bolt flanged housing	
					
Designation	<b>GEH...PBS</b>	<b>GEH...BT</b>	<b>GEH...BT GRG...RABR</b>	<b>FLAN...LST</b> (2 pieces)	<b>FLAN...MST</b> (2 pieces)
Shaft diameter d					
<b>RAE...-XL-NPP(-B)</b> 20 mm – 30 mm			<b>RPB...-XL</b> page 318 d = 30 mm	<b>RALT...-XL</b> page 322	
<b>RAE...-XL-NPP(-B)</b> 12 mm – 40 mm		<b>PBS...-XL</b> page 318	<b>PB...-XL</b> page 318		<b>RAT...-XL</b> page 322
<b>GRAE...-XL-NPP-B</b> 20 mm – 60 mm					
<b>(G)E...-XL-KRR-B</b> 17 mm – 60 mm		To be ordered separately	To be ordered separately	To be ordered separately	To be ordered separately
<b>GE...-XL-KTT-B</b> 20 mm – 60 mm		To be ordered separately	To be ordered separately		To be ordered separately
<b>GE...-XL-KLL-B</b> 20 mm – 50 mm		To be ordered separately	To be ordered separately		To be ordered separately
<b>GLE...-XL-KRR-B</b> 20 mm – 60 mm		To be ordered separately	To be ordered separately		To be ordered separately
<b>GSH...-XL-2RSR-B</b> 20 mm – 50 mm		To be ordered separately	To be ordered separately		To be ordered separately
<b>(G)AY...-XL-NPP-B</b> 12 mm – 60 mm		To be ordered separately	<b>PBY...-XL</b> page 318		<b>RATY...-XL</b> page 322
<b>GYE...-XL-KRR-B</b> 12 mm – 60 mm		To be ordered separately	To be ordered separately		To be ordered separately

Catalogue range, for dimension table see page number specified.  
Please contact us for details about other sizes and combinations.

 Combinations not possible or not advisable.

<sup>1)</sup> Housings have a Corrotect coating, suffix FA125.



Three-bolt flanged housing						Take-up housing
						
<b>FLAN...CSLT</b> <b>FLAN...CST</b>	<b>FLAN...RCSMF</b> <b>GRG...RCSM</b>	<b>FLAN...MSB</b> (2 pieces)	<b>FLAN...MSA</b> <b>FLAN...MSB</b>	<b>FLAN...LSTR</b> (2 pieces)	<b>FLAN...MSTR</b> (2 pieces)	<b>GEH...MSTU</b>
<b>PCSLT...-XL</b> page 322	<b>RCSMF...-XL</b> page 324 d = 30 mm			<b>RALTR...-XL</b> page 326		
	<b>RCSMF...-XL</b> page 324	<b>RA...-XL</b> page 328			<b>RATR...-XL</b> page 326	<b>MSTU...-XL</b> page 332
		<b>RA...-XL</b> page 328	<b>GRA...-XL</b> page 328			
		To be ordered separately	To be ordered separately		<b>RRTR...-XL</b> page 326	To be ordered separately
		To be ordered separately	To be ordered separately		To be ordered separately	To be ordered separately
		To be ordered separately	To be ordered separately		To be ordered separately	To be ordered separately
		To be ordered separately	To be ordered separately		To be ordered separately	To be ordered separately
		To be ordered separately	To be ordered separately		To be ordered separately	To be ordered separately
		<b>RAY...-XL</b> page 328			<b>RATRY...-XL</b> page 326	To be ordered separately
					To be ordered separately	To be ordered separately



# Housing units with sheet steel housing

## Features

INA housing units are available as plummer block, flanged and take-up housing units in numerous different designs. The units are ready-to-fit and comprise INA sheet steel housings in which INA radial insert ball bearings are fitted.

Due to the spherical outside surface of the bearing outer ring and the concave housing bore, housing units can compensate for static angular misalignment of the shaft, see page 315.

The housings are screw mounted on the adjacent construction. Less stringent tolerances are sufficient for the screw mounting surfaces, see page 317.



In order to ensure function and reliability under all operating conditions, the bearings and housings are matched to each other with a defined swivel moment after mounting.

The swivel moment can be requested from Schaeffler.

## X-life

Numerous sizes are supplied in the X-life design. These products are indicated in the dimension tables.

Radial insert ball bearings of X-life quality have, for example, lower roughness Ra and higher geometrical accuracy of the raceways than comparable designs that are not X-life. As a result, these bearings have higher load carrying capacity and longer rating life although their dimensions are identical. In certain applications, this means that a smaller bearing arrangement can be designed.

Radial insert ball bearings of X-life quality have an eccentric locking collar of an improved design and the quantity and distribution of the lubricant has been optimised. Housings ASE have additional crosspieces on the underside. For extreme requirements, the cage and seal material in the high and low temperature designs (suffix FA101) has been significantly improved in comparison with earlier versions.

## Plummer block and flanged housing units

Sheet steel housings are two-piece units made from steel strip of deep drawn quality and as standard have a Corrotect coating, *Figure 1* and *Figure 2*. Corrosion-resistant sheet steel housing units RRY.-VA and GRRY.-VA are made from corrosion-resistant steel, see page 380.

Units with sheet steel housings are suitable for moderate loads and lightweight constructions.

PB...XL

*Figure 1*  
Plummer block housing unit,  
sheet steel housing

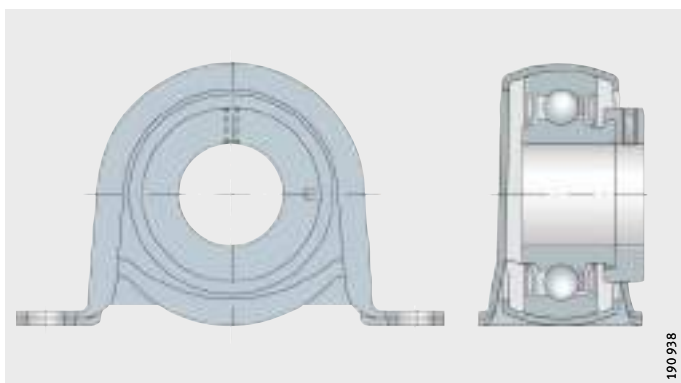

GRA...XL

*Figure 2*  
Flanged housing unit,  
sheet steel housing

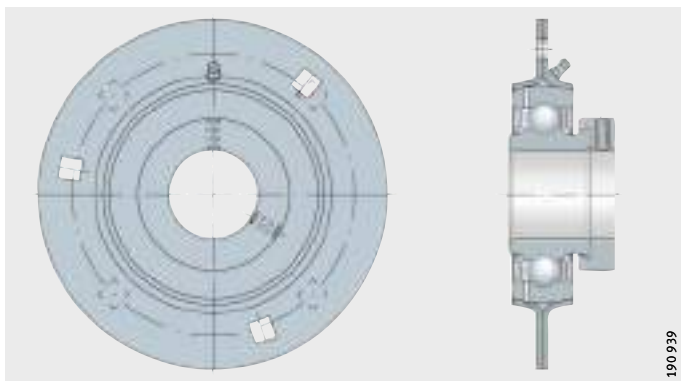

## Plummer block and flanged housing units with rubber interliner

In addition to the normal plummer block and flanged housing units, there is also a design with a rubber interliner on the bearing outer ring, *Figure 3*. This interliner absorbs shocks and vibrations and thus gives damping of running noises.

RCSMF...XL

*Figure 3*  
Flanged housing unit  
with rubber interliner

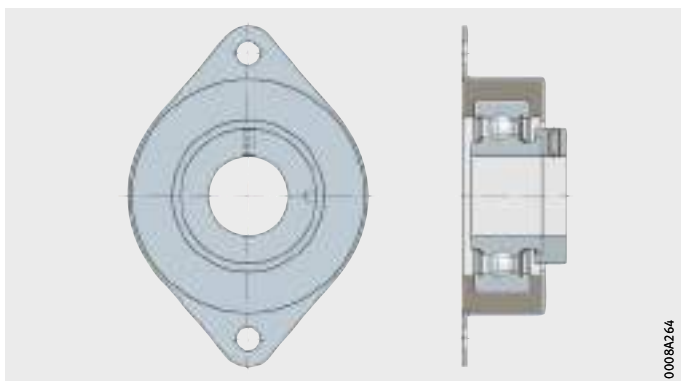

# Housing units with sheet steel housing

## Take-up housing units

The units are two-piece sheet steel housings and have a displacement facility, *Figure 4*. They are used where shafts must carry out long displacement motions.

MSTU..-XL

*Figure 4*  
Take-up housing unit,  
sheet steel housing

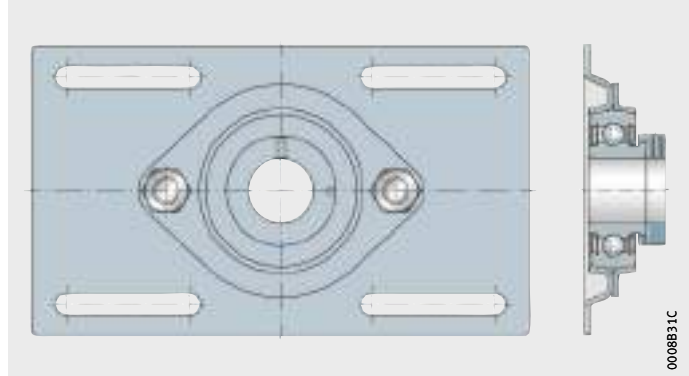

## Operating temperature

Housing units with a rubber interliner are suitable for operating temperatures from  $-20\text{ }^{\circ}\text{C}$  to  $+85\text{ }^{\circ}\text{C}$ .

Housing units without a rubber interliner are suitable for operating temperatures from  $-20\text{ }^{\circ}\text{C}$  to  $+100\text{ }^{\circ}\text{C}$ . Temporary temperature peaks are possible up to  $+120\text{ }^{\circ}\text{C}$ .

## Lubrication

The flanged housing unit GRA..-XL can be relubricated by means of a lubrication nipple.

## Corrosion-resistant units

The housing units are also available in a corrosion-resistant design. The two-piece sheet steel housings have the suffix VA and are also available in a design with a relubrication facility, see section Radial insert ball bearings and housing units, corrosion-resistant, page 349.

They are used where moisture, contaminated water, salt spray mist, weakly alkaline or weakly acidic cleaning agents are present.

## Market sectors

In addition to the comprehensive catalogue range, we also supply housing units for special applications.

Examples include:

- specially sealed flanged housing units for plough discs
- other designs with special greases or seals are available. Please contact us if necessary.

## Suffixes

Suffixes for available designs: see table.

## Available designs

Suffix	Description	Design
FA106	Bearing subjected to special noise testing	Standard
FA125	With Corrotect coating	

## Design and safety guidelines

The chapter Technical principles brings together the essential guidelines on the design of bearing arrangements, lubrication, mounting and dismantling and the operation of bearings, see page 32.

INA radial insert ball bearings and INA housings are matched to each other and, as a unit, give particularly robust and economical bearing arrangements.

## Compensation of static misalignments

Bearings with a spherical outer ring, fitted in housings with a concave bore, can compensate for static misalignment of the shaft or housing, *Figure 5* and *Figure 6*. In the case of flanged housing units GRA with a relubrication facility, the functional capability of lubrication must be taken into consideration. Please contact us in this case.



The units must not be used to support swivelling or tumbling motion.

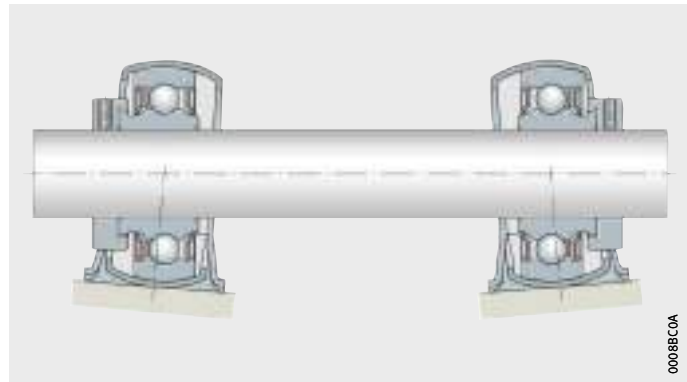

*Figure 5*  
Compensation  
of static housing misalignment

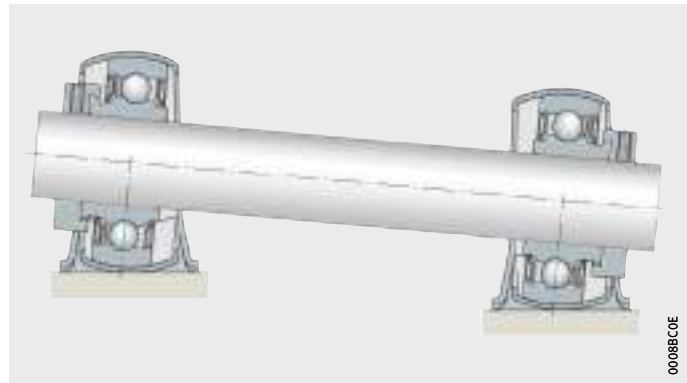

*Figure 6*  
Compensation  
of static shaft misalignment



## Housing units with sheet steel housing

### Speed limits for radial insert ball bearings

The speed limits are dependent on the load, the clearance between the bearing bore and shaft and the friction of the seals in bearings with contact seals, see page 148.

### Load carrying capacity of housings



Due to their versatile characteristics, INA housing units can be easily used in almost all industrial sectors.

If bearing arrangements are planned for equipment in which a malfunction could be hazardous to persons or an unplanned stoppage of the machine could cause major disruption, it is essential that you consult us before proceeding with the design.

### Radial load carrying capacity

Sheet steel housings are suitable for moderate loads.

The permissible radial load carrying capacity  $C_{0rG}$  of sheet steel housings is given in the dimension tables.

### Axial load carrying capacity

The permissible axial load carrying capacity of sheet steel housings is dependent on the value for the radial load carrying capacity, see table.

### Permissible axial load carrying capacity

Units with sheet steel housings	Axial load carrying capacity <sup>1)</sup>
MSTU	$0,20 \times C_{0rG}$
PHUSE	$0,25 \times C_{0rG}$
PB, PBY, RPB	$0,33 \times C_{0rG}$
PBS	$0,20 \times C_{0rG}$
RALTR, RATR, RATRY, RRTR	$0,50 \times C_{0rG}$
PCSLT, RAT, RATY, RALT	$0,50 \times C_{0rG}$
RCSMF	$0,33 \times C_{0rG}$
RA, RAY, GRA, RRY, GRRY	$0,50 \times C_{0rG}$

<sup>1)</sup>  $C_{0rG}$  is the permissible radial load carrying capacity of the sheet steel housing according to the dimension table.

## Design of adjacent construction

The permissible shaft tolerance is dependent on the speed, load and the radial insert ball bearing fitted. Shafts of the tolerance classes h6  $\oplus$  to h9  $\oplus$  can be used. Conventional drawn shafts will suffice for most applications.

## Screw mounting surfaces

Recommendations for the screw mounting surfaces are as follows:

- roughness of the screw mounting surface max. Ra 12,5 (Rzmax 63)
- geometrical and positional tolerance 0,04/100 concave, spherical not permissible.

## Fixing screws

The screw connection should be designed in accordance with VDI 2230; friction coefficient  $\mu = 0,12$  (90%).

Screws of grade 8.8 or better can be used for fixing.

The maximum tightening torques applicable to this screw grade must not be exceeded even if screws of a higher grade are used.

In principle, we recommend that the screw connection should only be tightened to 70% of the values stated in the standard.

For fixing, hexagonal socket head screws in accordance with DIN EN ISO 4762 or hexagonal socket head screws with a coarse pitch full thread in accordance with DIN EN ISO 4017 should be used. The screws should be combined as a minimum with a washer in accordance with DIN EN ISO 7089 or DIN EN ISO 7090.

Screws and accessories for location are not included in the delivery.

## Accuracy

The sheet steel housings correspond predominantly to DIN 626-2 and ISO 3228, insofar as they are described therein.

The accuracy of the radial insert ball bearings mounted must be observed, see page 150.

## Dimensional tolerances

The dimensional tolerances for the sheet steel housings correspond to DIN 6930. For location of sheet steel housings with a square bore, the use of mushroom head bolts with a square neck (DIN 603) or a short square neck (DIN 11015) is recommended.



# Plummer block housing units

Sheet steel housing  
With or without rubber interliner

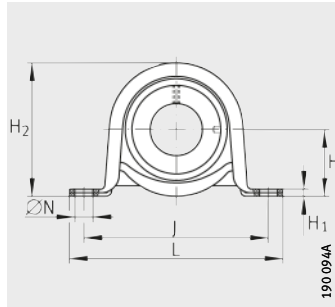

PB..-XL, RPB..-XL

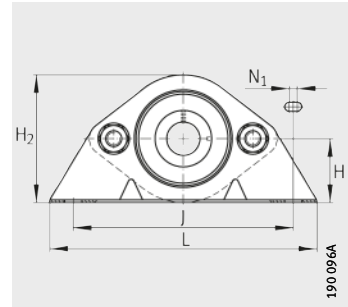

PBS..-XL

**Dimension table** - Dimensions in mm

Designation				Mass m ≈ kg	Dimensions					
Unit	Housing <sup>1)</sup>	Rubber interliner	Radial insert ball bearing		d	H	J	L	A	A <sub>1</sub>
<b>PB12-XL</b>	GEH40-BT	–	RAE12-XL-NPP-B	0,17	<b>12</b>	22,2	68	85,7	25,4	18,4
<b>RPB12-XL</b>	GEH47-BT	GRG.RABR40/47	RAE12-XL-NPP-B	0,23	<b>12</b>	25,4	76	98,7	31,8	22,3
<b>PBS12-XL</b>	GEH40-PBS	–	RAE12-XL-NPP-B	0,32	<b>12</b>	30,2	92	123,8	32,5	14,2
<b>PB15-XL</b>	GEH40-BT	–	RAE15-XL-NPP-B	0,17	<b>15</b>	22,2	68	85,7	25,4	18,4
<b>RPB15-XL</b>	GEH47-BT	GRG.RABR40/47	RAE15-XL-NPP-B	0,23	<b>15</b>	25,4	76	98,4	31,8	22,3
<b>PBS15-XL</b>	GEH40-PBS	–	RAE15-XL-NPP-B	0,32	<b>15</b>	30,2	92	123,8	32,5	14,2
<b>PB17-XL</b>	GEH40-BT	–	RAE17-XL-NPP-B	0,17	<b>17</b>	22,2	68	85,7	25,4	18,4
<b>RPB17-XL</b>	GEH47-BT	GRG.RABR40/47	RAE17-XL-NPP-B	0,23	<b>17</b>	25,4	76	98,4	31,8	22,3
<b>PBS17-XL</b>	GEH40-PBS	–	RAE17-XL-NPP-B	0,32	<b>17</b>	30,2	92	123,8	32,5	14,2
<b>PB20-XL</b>	GEH47-BT	–	RAE20-XL-NPP-B	0,27	<b>20</b>	25,4	76	98,4	31,8	22,3
<b>RPB20-XL</b>	GEH52-BT	GRG.RABR47/52-AH01	RAE20-XL-NPP-B	0,28	<b>20</b>	28,6	86	108	31,8	23,5
<b>PBS20-XL</b>	GEH47-PBS	–	RAE20-XL-NPP-B	0,45	<b>20</b>	33,6	97	127	33	15,8
<b>PB25-XL</b>	GEH52-BT	–	RAE25-XL-NPP-B	0,3	<b>25</b>	28,6	86	108	31,8	23,5
<b>RPB25-XL</b>	GEH62-BT	GRG.RABR52/62-AH01	RAE25-XL-NPP-B	0,38	<b>25</b>	33,3	95	117,5	38	26,5
<b>PBS25-XL</b>	GEH52-PBS	–	RAE25-XL-NPP-B	0,49	<b>25</b>	36,5	95,5	133,5	34,1	17,4
<b>PB30-XL</b>	GEH62-BT	–	RAE30-XL-NPP-B	0,5	<b>30</b>	33,3	95	117,5	38	26,5
<b>RPB30-XL</b>	GEH62-BT	GRG.RABR55/62	RAE30-XL-NPP-B	0,45	<b>30</b>	33,3	95	117,5	38	26,5
<b>PBS30-XL</b>	GEH62-PBS	–	RAE30-XL-NPP-B	0,79	<b>30</b>	42,9	119	159	38,9	17,4
<b>PBS35-XL</b>	GEH72-PBS	–	RAE35-XL-NPP-B	1,05	<b>35</b>	47,6	127	165	46,1	22,2
<b>PBS40-XL</b>	GEH80-PBS	–	RAE40-XL-NPP-B	1,33	<b>40</b>	55	136,5	180	53,5	23

<sup>1)</sup> Housing with Corrotect coating, suffix FA125.



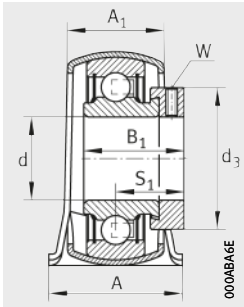

PB..-XL

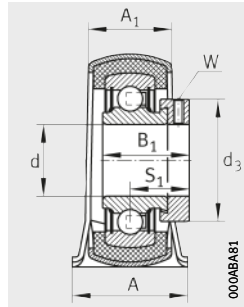

RPB..-XL

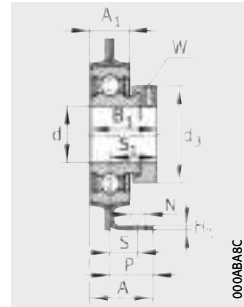

PBS..-XL

										Width across flats W	Load carrying capacity			
											Bearing			Housing $C_{OrG}$ N
											Basic load ratings		Fatigue limit load $C_{Ur}$ N	
$H_1$	$H_2$	N		$N_1$	$B_1$	$S_1$	S	P	$d_3$ max.		dyn. $C_r$ N	stat. $C_{Or}$ N		
2,6	43,2	9,5	-	-	28,6	22,1	-	-	28,4	3	10 100	4 750	241	1 350
3,3	50,1	9,5	-	-	28,6	22,1	-	-	28,4	3	10 100	4 750	241	900
2,6	59,6	-	10,5	5,6	28,6	22,1	15	25,4	28,4	3	10 100	4 750	241	2 700
2,6	43,2	9,5	-	-	28,6	22,1	-	-	28,4	3	10 100	4 750	241	1 350
3,3	50,1	9,5	-	-	28,6	22,1	-	-	28,4	3	10 100	4 750	241	900
2,6	59,6	-	10,5	5,6	28,6	22,1	15	25,4	28,4	3	10 100	4 750	241	2 700
2,6	43,2	9,5	-	-	28,6	22,1	-	-	28,4	3	10 100	4 750	241	1 350
3,3	50,1	9,5	-	-	28,6	22,1	-	-	28,4	3	10 100	4 750	241	900
2,6	59,6	-	10,5	5,6	28,6	22,1	15	25,4	28,4	3	10 100	4 750	241	2 700
3,3	50,1	9,5	-	-	31	23,5	-	-	33	3	13 600	6 600	335	1 600
4	56,5	11,5	-	-	31	23,5	-	-	33	3	13 600	6 600	335	1 100
3	66,8	-	10,5	5,6	31	23,5	15	25,4	33	3	13 600	6 600	335	3 200
4	56,5	11,5	-	-	31	23,5	-	-	37,5	3	14 900	7 800	395	1 800
4	66,1	11,5	-	-	31	23,5	-	-	37,5	3	14 900	7 800	395	1 400
3,4	72	-	10,5	9,5	31	23,5	14,3	25,4	37,5	3	14 900	7 800	395	3 600
4	66,1	11,5	-	-	35,8	26,8	-	-	44	4	20 700	11 300	570	2 700
4	66,1	11,5	-	-	26,5	20	-	-	42,5	2,5	14 100	8 300	420	1 400
3,4	85	-	13,5	8	35,8	26,8	16	30,2	44	4	20 700	11 300	570	3 600
4	94,4	-	13,5	8	39	29,5	20,7	35	55	5	27 500	15 300	770	4 100
4	106	-	13,5	8	43,8	32,8	25	40	58	5	34 500	19 800	1 010	4 500



# Plummer block housing units

Sheet steel housing  
Without rubber interliner

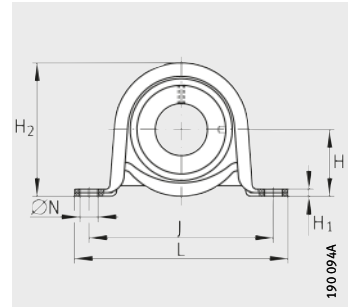

PBY..-XL



**Dimension table** - Dimensions in mm

Designation			Mass m ≈ kg	Dimensions					
Unit	Housing <sup>1)</sup>	Radial insert ball bearing		d	H	J	L	A	A <sub>1</sub>
<b>PBY12-XL</b>	GEH40-BT	AY12-XL-NPP-B	0,15	<b>12</b>	22,2	68	85,7	25,4	18,4
<b>PBY15-XL</b>	GEH40-BT	AY15-XL-NPP-B	0,15	<b>15</b>	22,2	68	85,7	25,4	18,4
<b>PBY17-XL</b>	GEH40-BT	AY17-XL-NPP-B	0,15	<b>17</b>	22,2	68	85,7	25,4	18,4
<b>PBY20-XL</b>	GEH47-BT	AY20-XL-NPP-B	0,22	<b>20</b>	25,4	76	98,4	31,8	22,3
<b>PBY25-XL</b>	GEH52-BT	AY25-XL-NPP-B	0,26	<b>25</b>	28,6	86	108	31,8	23,5
<b>PBY30-XL</b>	GEH62-BT	AY30-XL-NPP-B	0,4	<b>30</b>	33,3	95	117,5	38	26,5

<sup>1)</sup> Housing with Corrotect coating, suffix FA125.

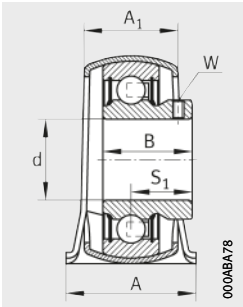

PBY..-XL

					Width across flats  W	Load carrying capacity			
						Bearing			Housing  C <sub>0rG</sub>  N
						Basic load ratings		Fatigue limit load	
H <sub>1</sub>	H <sub>2</sub>	N	B	S <sub>1</sub>		dyn. C <sub>r</sub> N	stat. C <sub>0r</sub> N	C <sub>ur</sub>  N	
2,6	43,2	9,5	22	16	2,5	10 100	4 750	241	1 350
2,6	43,2	9,5	22	16	2,5	10 100	4 750	241	1 350
2,6	43,2	9,5	22	16	2,5	10 100	4 750	241	1 350
3,3	50,1	9,5	25	18	2,5	13 600	6 600	335	1 600
4	56,5	11,5	27	19,5	2,5	14 900	7 800	395	1 800
4	66,1	11,5	30	21	3	20 700	11 300	570	2 700



# Two-bolt flanged housing units

Sheet steel housing

X-life

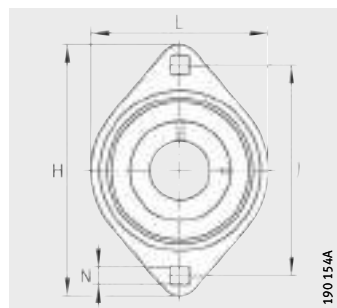

RAT...-XL, RALT...-XL, PCSLT...-XL,  
RATY...-XL

**Dimension table** - Dimensions in mm

Designation			Mass	Dimensions				
Unit	Housing <sup>1)</sup>	Radial insert ball bearing		d	H	J	L	A
			m ≈ kg					
<b>RAT12-XL</b>	2× FLAN40-MST	RAE12-XL-NPP-B	0,19	<b>12</b>	81	63,5	58,7	7
<b>RAT15-XL</b>	2× FLAN40-MST	RAE15-XL-NPP-B	0,19	<b>15</b>	81	63,5	58,7	7
<b>RAT17-XL</b>	2× FLAN40-MST	RAE17-XL-NPP-B	0,19	<b>17</b>	81	63,5	58,7	7
<b>RALT20-XL-FA125.8</b>	2× FLAN42-LST	RALE20-XL-NPP-B	0,17	<b>20</b>	81	63,5	58,7	7
<b>PCSLT20-XL</b>	1× FLAN42-CSLT, 1× FLAN42-CST	RALE20-XL-NPP-B	0,22	<b>20</b>	90,5	71,4	66	14
<b>RAT20-XL</b>	2× FLAN47-MST	RAE20-XL-NPP-B	0,27	<b>20</b>	90,5	71,5	66	8
<b>PCSLT25-XL</b>	1× FLAN47-CSLT, 1× FLAN47-CST	RALE25-XL-NPP-B	0,25	<b>25</b>	95,2	76,2	71	16
<b>RALT25-XL</b>	2× FLAN47-LST	RALE25-XL-NPP-B	0,22	<b>25</b>	95,2	76	71	7,1
<b>RAT25-XL</b>	2× FLAN52-MST	RAE25-XL-NPP-B	0,34	<b>25</b>	95,2	76,2	71	8,7
<b>PCSLT30-XL</b>	1× FLAN55-CSLT, 1× FLAN55-CST	RALE30-XL-NPP-B	0,3	<b>30</b>	112,5	90,5	84	16
<b>RAT30-XL</b>	2× FLAN62-MST	RAE30-XL-NPP-B	0,49	<b>30</b>	112,7	90,5	84	8,7
<b>RAT35-XL</b>	2× FLAN72-MST	RAE35-XL-NPP-B	0,72	<b>35</b>	123	100	93,7	10,5
<b>RAT40-XL</b>	2× FLAN80-MST	RAE40-XL-NPP-B	0,98	<b>40</b>	151	119	100	11,5

**Dimension table** - Dimensions in mm

Designation			Mass	Dimensions				
Unit	Housing <sup>1)</sup>	Radial insert ball bearing		d	H	J	L	A
			m ≈ kg					
<b>RATY12-XL</b>	2× FLAN40-MST	AY12-XL-NPP-B	0,14	<b>12</b>	81	63,5	58,7	7
<b>RATY15-XL</b>	2× FLAN40-MST	AY15-XL-NPP-B	0,13	<b>15</b>	81	63,5	58,7	7
<b>RATY17-XL</b>	2× FLAN40-MST	AY17-XL-NPP-B	0,12	<b>17</b>	81	63,5	58,7	7
<b>RATY20-XL</b>	2× FLAN47-MST	AY20-XL-NPP-B	0,22	<b>20</b>	90,5	71,5	66	8
<b>RATY25-XL</b>	2× FLAN52-MST	AY25-XL-NPP-B	0,26	<b>25</b>	95,2	76,2	71	8,7
<b>RATY30-XL</b>	2× FLAN62-MST	AY30-XL-NPP-B	0,41	<b>30</b>	112,7	90,5	84	8,7
<b>RATY35-XL</b>	2× FLAN72-MST	GAY35-XL-NPP-B	0,56	<b>35</b>	123	100	93,7	10,5
<b>RATY40-XL</b>	2× FLAN80-MST	GAY40-XL-NPP-B	0,85	<b>40</b>	151	119	100	11,5

<sup>1)</sup> Housing with Corrotect coating, suffix FA125.

<sup>2)</sup> Includes radial insert ball bearing with relubrication facility.

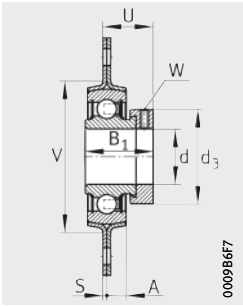

RAT..-XL, RALT..-XL

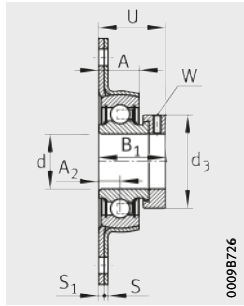

PCSLT..-XL

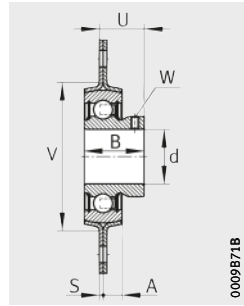

RATY..-XL

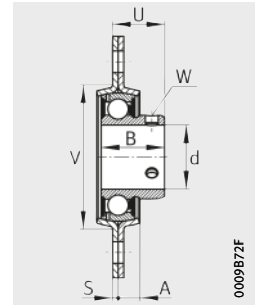

RATY35-XL<sup>2)</sup>,  
RATY40-XL<sup>2)</sup>

								Width across flats  W	Load carrying capacity			
									Bearing			Housing  C <sub>Or G</sub>  N
									Basic load ratings		Fatigue limit load  C <sub>ur</sub>  N	
A <sub>2</sub>	N	B <sub>1</sub>	S <sub>1</sub>	S	U	V	d <sub>3</sub> max.	dyn. C <sub>r</sub> N	stat. C <sub>Or</sub> N			
-	7,1	28,6	-	2	24	48	28,4	3	10 100	4 750	241	2 700
-	7,1	28,6	-	2	24	48	28,4	3	10 100	4 750	241	2 700
-	7,1	28,6	-	2	24	48	28,4	3	10 100	4 750	241	2 700
-	7	24,5	-	2	20,46	48	30	2,5	10 000	5 000	255	2 700
7,5	-	24,5	3	2	26,1	-	30	2,5	10 000	5 000	255	4 200
-	8,7	31	-	2	25,5	55	33	3	13 600	6 600	335	3 200
8,5	-	25,5	3	2	28	-	36	2,5	10 700	5 900	295	4 500
-	8,7	25,5	-	2	21,4	55	36	2,5	10 700	5 900	295	3 000
-	8,7	31	-	2	25,5	60	37,5	3	14 900	7 800	395	3 650
9	-	26,5	3,5	2,5	29	-	42,5	2,5	14 100	8 300	420	6 000
-	10,5	35,8	-	2,5	29,2	71	44	4	20 700	11 300	570	5 000
-	10,5	39	-	2,5	31,5	81	55	5	27 500	15 300	770	6 300
-	13,5	43,8	-	3,5	36,2	90	58	5	34 500	19 800	1 010	7 000

					Width across flats  W	Load carrying capacity			
						Bearing			Housing  C <sub>Or G</sub>  N
						Basic load ratings		Fatigue limit load  C <sub>ur</sub>  N	
N	B	S	U	V	dyn. C <sub>r</sub> N	stat. C <sub>Or</sub> N			
7,1	22	2	18	48	2,5	10 100	4 750	241	2 700
7,1	22	2	18	48	2,5	10 100	4 750	241	2 700
7,1	22	2	18	48	2,5	10 100	4 750	241	2 700
8,7	25	2	20	55	2,5	13 600	6 600	335	3 200
8,7	27	2	21,5	60	2,5	14 900	7 800	395	3 650
10,5	30	2,5	23,5	71	3	20 700	11 300	570	5 000
10,5	35	2,5	28	81	3	27 500	15 300	770	6 300
13,5	39,5	3,5	32,5	90	4	34 500	19 800	1 010	7 000



# Two-bolt flanged housing units

Sheet steel housing  
With rubber interliner

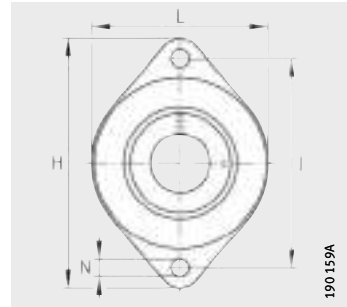

RCSMF..-XL

**Dimension table** - Dimensions in mm

Designation				Mass m ≈ kg	Dimensions				
Unit	Housing <sup>1)</sup>	Rubber interliner	Radial insert ball bearing		d	H	J	L	A
<b>RCSMF12-XL</b>	FLAN65-RCSMF	GRG.RCSM40/65	RAE12-XL-NPP-FA106	0,27	<b>12</b>	114	92	70	27
<b>RCSMF15-XL</b>	FLAN65-RCSMF	GRG.RCSM40/65	RAE15-XL-NPP-FA106	0,27	<b>15</b>	114	92	70	27
<b>RCSMF17-XL</b>	FLAN65-RCSMF	GRG.RCSM40/65	RAE17-XL-NPP-FA106	0,27	<b>17</b>	114	92	70	27
<b>RCSMF20-XL</b>	FLAN65-RCSMF	GRG.RCSM47/65	RAE20-XL-NPP-FA106	0,32	<b>20</b>	114	92	70	27
<b>RCSMF25-XL</b>	FLAN65-RCSMF	GRG.RCSM52/65	RAE25-XL-NPP-FA106	0,33	<b>25</b>	114	92	70	27
<b>RCSMF30-XL</b>	FLAN65-RCSMF	GRG.RCSM55/65	RAE30-XL-NPP-FA106	0,32	<b>30</b>	114	92	70	27

<sup>1)</sup> Housing with Corrotect coating, suffix FA125.

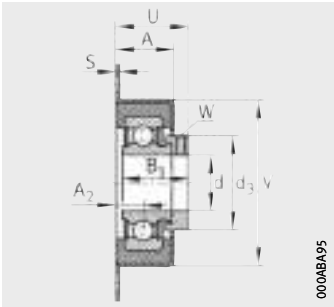

00048A95

RCSMF..-XL

							Width across flats  W	Load carrying capacity			
								Bearing			Housing  C <sub>0r G</sub>  N
								Basic load ratings		Fatigue limit load	
A <sub>2</sub>	N	B <sub>1</sub>	S	U	V	d <sub>3</sub> max.		dyn. C <sub>r</sub> N	stat. C <sub>0r</sub> N	C <sub>ur</sub> N	
12,7	10,5	28,6	1,5	34,8	68	28,4	3	10 100	4 750	241	900
12,7	10,5	28,6	1,5	34,8	68	28,4	3	10 100	4 750	241	900
12,7	10,5	28,6	1,5	34,8	68	28,4	3	10 100	4 750	241	900
12,7	10,5	31	1,5	36,2	68	33	3	13 600	6 600	335	1 100
12,7	10,5	31	1,5	36,2	68	37,5	3	14 900	7 800	395	1 400
15	10,5	26,5	1,5	35	68	42,5	2,5	14 100	8 300	420	1 400



# Three-bolt flanged housing units

Sheet steel housing

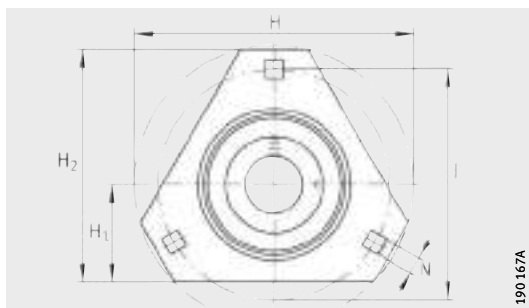

RATR...XL, RALTR...XL, RRTR...XL, RATRY...XL

X-life

**Dimension table** - Dimensions in mm

Designation			Mass m ≈ kg	Dimensions				
Unit	Housing <sup>1)</sup>	Radial insert ball bearing		d	H	J	A	H <sub>1</sub>
<b>RALTR20-XL</b>	2× FLAN42-LSTR <sup>2)</sup>	RALE20-XL-NPP-B	0,21	<b>20</b>	90,5	71,5	7,2	33,3
<b>RATR20-XL</b>	2× FLAN47-MSTR	RAE20-XL-NPP-B	0,28	<b>20</b>	90,5	71,5	8	33,3
RALTR25-XL <sup>3)</sup>	2× FLAN47-LSTR <sup>2)</sup>	RALE25-XL-NPP-B	0,23	<b>25</b>	95,3	76	7,2	34,9
<b>RATR25-XL</b>	2× FLAN52-MSTR	RAE25-XL-NPP-B	0,32	<b>25</b>	95,3	76	8,7	34,9
RRTR25-XL <sup>3)</sup>	2× FLAN52-MSTR	E25-XL-KRR-B	0,37	<b>25</b>	95,3	76	8,7	34,9
<b>RATR30-XL</b>	2× FLAN62-MSTR	RAE30-XL-NPP-B	0,43	<b>30</b>	112,7	90,5	8,7	38,1
RRTR30-XL <sup>3)</sup>	2× FLAN62-MSTR	E30-XL-KRR-B	0,5	<b>30</b>	112,7	90,5	8,7	38,1
<b>RATR35-XL</b>	2× FLAN72-MSTR	RAE35-XL-NPP-B	0,75	<b>35</b>	122	100	9,5	44,5
<b>RRTR35-XL</b>	2× FLAN72-MSTR	E35-XL-KRR-B	0,83	<b>35</b>	122	100	9,5	44,5

**Dimension table** - Dimensions in mm

Designation			Mass m ≈ kg	Dimensions				
Unit	Housing <sup>1)</sup>	Radial insert ball bearing		d	H	J	A	H <sub>1</sub>
<b>RATRY30-XL</b>	2× FLAN62-MSTR	AY30-XL-NPP-B	0,41	<b>30</b>	112,7	90,5	8,7	38,1
<b>RATRY35-XL</b>	2× FLAN72-MSTR	GAY35-XL-NPP-B	0,47	<b>35</b>	122	100	9,5	44,5

<sup>1)</sup> Housing with Corrotect coating, suffix FA125.

<sup>2)</sup> Light series.

<sup>3)</sup> Housing and radial insert ball bearing must be ordered separately.



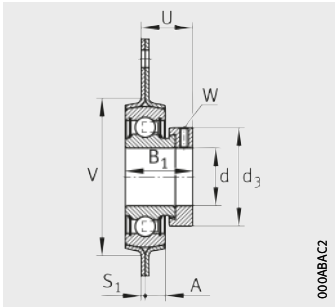

RATR...-XL, RALTR...-XL

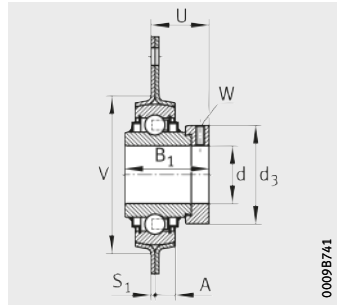

RRTR...-XL

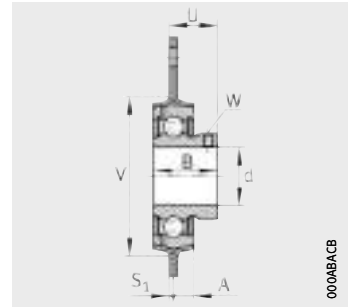

RATRY...-XL

							Width across flats W	Load carrying capacity			
								Bearing			Housing C <sub>0rG</sub> N
							Basic load ratings		Fatigue limit load		
H <sub>2</sub>	N	B <sub>1</sub>	S <sub>1</sub>	U	V	d <sub>3</sub> max.	dyn. C <sub>r</sub> N	stat. C <sub>0r</sub> N	C <sub>ur</sub> N		
76,2	8,7	24,5	2	20,6	49	30	2,5	10 000	5 000	255	2 600
76,2	8,7	31	2	25,5	55	33	3	13 600	6 600	335	3 200
80,5	8,7	25,5	2	21,4	54	36	2,5	10 700	5 900	295	3 000
80,5	8,7	31	2	25,5	60	37,5	3	14 900	7 800	395	3 650
80,5	8,7	44,5	2	28,9	60	37,5	3	14 900	7 800	395	3 650
93	10,5	35,8	2,5	29,2	71	44	4	20 700	11 300	570	5 000
93	10,5	48,5	2,5	32,6	71	44	4	20 700	11 300	570	5 000
105,6	10,5	39	2,5	31,9	81	55	5	27 500	15 300	770	6 400
105,6	10,5	51,3	2,5	34,8	81	55	5	27 500	15 300	770	6 400

						Width across flats W	Load carrying capacity			Housing C <sub>0rG</sub> N
							Bearing		Fatigue limit load C <sub>ur</sub> N	
						Basic load ratings				
H <sub>2</sub>	N	B	S <sub>1</sub>	U	V	dyn. C <sub>r</sub> N	stat. C <sub>0r</sub> N			
93	10,5	30	2,5	23,5	71	20 700	11 300	570	5 000	
105,6	10,5	35	2,5	28	81	27 500	15 300	770	6 400	



# Three-bolt and four-bolt flanged housing units

Sheet steel housing  
Eccentric locking collar

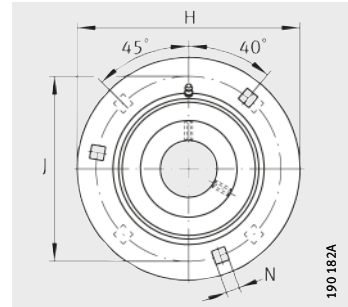

GRA...XL

**Dimension table** - Dimensions in mm

Designation			Mass m ≈ kg	Dimensions			
Unit	Housing <sup>1)</sup>	Radial insert ball bearing		d	H	J	A
<b>RA12-XL<sup>2)</sup></b>	2×FLAN40-MSB	RAE12-XL-NPP-B	0,23	<b>12</b>	81	63,5	7
<b>RA15-XL</b>	2×FLAN40-MSB	RAE15-XL-NPP-B	0,23	<b>15</b>	81	63,5	7
<b>RA17-XL</b>	2×FLAN40-MSB	RAE17-XL-NPP-B	0,23	<b>17</b>	81	63,5	7
<b>GRA20-XL<sup>3)</sup></b>	1×FLAN47-MSB, 1×FLAN47-MSA	GRAE20-XL-NPP-B	0,32	<b>20</b>	90,5	71,5	8
<b>RA20-XL</b>	2×FLAN47-MSB	RAE20-XL-NPP-B	0,32	<b>20</b>	90,5	71,5	8
<b>GRA25-XL<sup>3)</sup></b>	1×FLAN52-MSB, 1×FLAN52-MSA	GRAE25-XL-NPP-B	0,37	<b>25</b>	95	76	8,7
<b>RA25-XL</b>	2×FLAN52-MSB	RAE25-XL-NPP-B	0,37	<b>25</b>	95	76	8,7
<b>GRA30-XL<sup>3)</sup></b>	1×FLAN62-MSB, 1×FLAN62-MSA	GRAE30-XL-NPP-B	0,61	<b>30</b>	112,7	90,5	8,7
<b>RA30-XL</b>	2×FLAN62-MSB	RAE30-XL-NPP-B	0,61	<b>30</b>	112,7	90,5	8,7
<b>GRA35-XL<sup>3)</sup></b>	1×FLAN72-MSB, 1×FLAN72-MSA	GRAE35-XL-NPP-B	0,85	<b>35</b>	122	100	9,5
<b>RA35-XL</b>	2×FLAN72-MSB	RAE35-XL-NPP-B	0,85	<b>35</b>	122	100	9,5
<b>GRA40-XL<sup>3)</sup></b>	1×FLAN80-MSB, 1×FLAN80-MSA	GRAE40-XL-NPP-B	1,36	<b>40</b>	147,5	119	10,3
<b>RA40-XL</b>	2×FLAN80-MSB	RAE40-XL-NPP-B	1,36	<b>40</b>	147,5	119	10,3
<b>GRA45-XL<sup>3)</sup></b>	1×FLAN85-MSB, 1×FLAN85-MSA	GRAE45-XL-NPP-B	1,41	<b>45</b>	149,2	120,5	11,1
<b>RA45-XL</b>	2×FLAN85-MSB	RAE45-XL-NPP-B	1,41	<b>45</b>	149,2	120,5	11,1
<b>GRA50-XL<sup>3)</sup></b>	1×FLAN90-MSB, 1×FLAN90-MSA	GRAE50-XL-NPP-B	1,68	<b>50</b>	155,5	127	11,1
<b>RA50-XL</b>	2×FLAN90-MSB	GRAE50-XL-NPP-B	1,68	<b>50</b>	155,5	127	11,1
<b>RA55-XL<sup>2)</sup></b>	2×FLAN100-MSB	GRAE55-XL-NPP-B	1,39	<b>55</b>	167	138	12,5
<b>RA60-XL<sup>2)</sup></b>	2×FLAN110-MSB	GRAE60-XL-NPP-B	2,54	<b>60</b>	176	148	12

<sup>1)</sup> Housing with Corrotect coating, suffix FA125.

<sup>2)</sup> Housing and radial insert ball bearing must be ordered separately.

<sup>3)</sup> Units with relubrication facility.

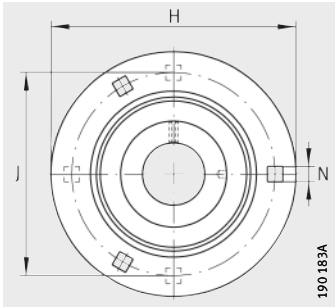

RA..-XL

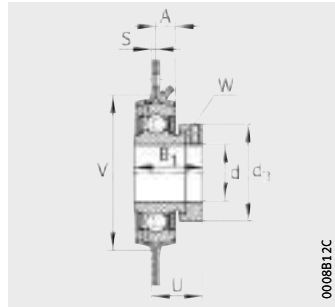

GRA..-XL

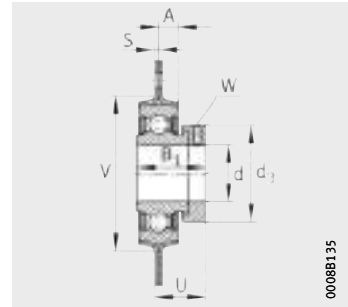

RA..-XL

						Number of screw mounting holes n	Width across flats W	Load carrying capacity			
								Bearing			Housing $C_{0rG}$ N
								Basic load ratings		Fatigue limit load	
N	$B_1$	S	U	V	$d_3$ max.			dyn. $C_r$ N	stat. $C_{0r}$ N	$C_{ur}$ N	
7,1	28,6	2	24	48	28,4	3	3	10 100	4 750	241	2 700
7,1	28,6	2	24	48	28,4	3	3	10 100	4 750	241	2 700
7,1	28,6	2	24	48	28,4	3	3	10 100	4 750	241	2 700
8,7	31	2	25,5	55	33	3	3	13 600	6 600	335	3 200
8,7	31	2	25,5	55	33	3	3	13 600	6 600	335	3 200
8,7	31	2	25,5	60	37,5	3	3	14 900	7 800	395	3 650
8,7	31	2	25,5	60	37,5	3	3	14 900	7 800	395	3 650
10,5	35,8	2,5	29,2	71	44	3	4	20 700	11 300	570	5 000
10,5	35,8	2,5	29,2	71	44	3	4	20 700	11 300	570	5 000
10,5	39	2,5	32	81	55	3	5	27 500	15 300	770	6 400
10,5	39	2,5	31,9	81	55	3	5	27 500	15 300	770	6 400
13,5	43,8	3,5	36,2	90	58	4	5	34 500	19 800	1 010	7 700
13,5	43,8	3,5	36,2	90	58	4	5	34 500	19 800	1 010	7 700
13,5	43,8	3,5	36,2	95	63	4	5	34 500	20 400	1 030	7 700
13,5	43,8	3,5	36,2	95	63	4	5	34 500	20 400	1 030	7 700
13,5	43,8	4	36,7	100	69	4	5	37 500	23 200	1 180	8 600
13,5	43,8	4	36,7	100	69	4	5	37 500	23 200	1 180	8 600
13,5	48,4	4	40,4	110	76	4	5	46 000	29 000	1 480	9 500
13,5	53,1	4	43,6	120	84	4	5	56 000	36 000	1 820	11 200



# Three-bolt and four-bolt flanged housing units

Sheet steel housing  
Grub screws in inner ring

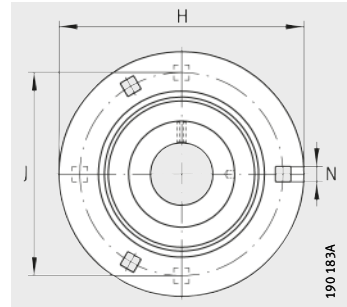

RAY..-XL

**Dimension table** - Dimensions in mm

Designation			Mass m ≈ kg	Dimensions			
Unit	Housing <sup>1)</sup>	Radial insert ball bearing		d	H	J	A
<b>RAY12-XL<sup>2)</sup></b>	2× FLAN40-MSB	AY12-XL-NPP-B	0,17	<b>12</b>	81	63,5	7
<b>RAY15-XL</b>	2× FLAN40-MSB	AY15-XL-NPP-B	0,16	<b>15</b>	81	63,5	7
<b>RAY17-XL<sup>2)</sup></b>	2× FLAN40-MSB	AY17-XL-NPP-B	0,15	<b>17</b>	81	63,5	7
<b>RAY20-XL</b>	2× FLAN47-MSB	AY20-XL-NPP-B	0,3	<b>20</b>	90,5	71,5	8
<b>RAY25-XL</b>	2× FLAN52-MSB	AY25-XL-NPP-B	0,34	<b>25</b>	95	76	8,7
<b>RAY30-XL</b>	2× FLAN62-MSB	AY30-XL-NPP-B	0,45	<b>30</b>	112,7	90,5	8,7
<b>RAY35-XL</b>	2× FLAN72-MSB	GAY35-XL-NPP-B	0,78	<b>35</b>	122	100	9,5
<b>RAY40-XL<sup>2)</sup></b>	2× FLAN80-MSB	GAY40-XL-NPP-B	1,25	<b>40</b>	147,5	119	10,3
<b>RAY50-XL<sup>2)</sup></b>	2× FLAN90-MSB	GAY50-XL-NPP-B	1,68	<b>50</b>	155,5	127	11,1
<b>RAY60-XL<sup>2)</sup></b>	2× FLAN110-MSB	GAY60-XL-NPP-B	2,13	<b>60</b>	176	148	12

<sup>1)</sup> Housing with Corrotect coating, suffix FA125.

<sup>2)</sup> Housing and radial insert ball bearing must be ordered separately.

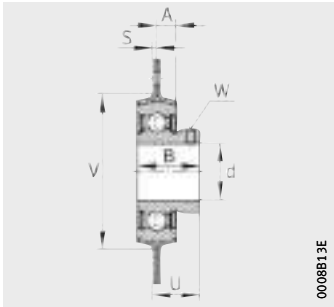

RAY..-XL

N					Number of screw mounting holes n	Width across flats W	Load carrying capacity			
							Bearing			Housing C <sub>0rG</sub> N
							Basic load ratings		Fatigue limit load	
						dyn. C <sub>r</sub> N	stat. C <sub>0r</sub> N	C <sub>ur</sub> N		
7,1	22	2	18	48	3	2,5	10 100	4 750	241	2 700
7,1	22	2	18	48	3	2,5	10 100	4 750	241	2 700
7,1	22	2	18	48	3	2,5	10 100	4 750	241	2 700
8,7	25	2	20	55	3	2,5	13 600	6 600	335	3 200
8,7	27	2	21,5	60	3	2,5	14 900	7 800	395	3 650
10,5	30	2,5	23,5	71	3	3	20 700	11 300	570	5 000
10,5	35	2,5	28	81	3	3	27 500	15 300	770	6 400
13,5	39,5	3,5	32,5	90	4	4	34 500	19 800	1 010	7 700
13,5	43	4	36	100	4	4	37 500	23 200	1 180	8 600
13,5	47	4	38	120	4	5	56 000	36 000	1 820	11 200



# Take-up housing units

Sheet steel housing

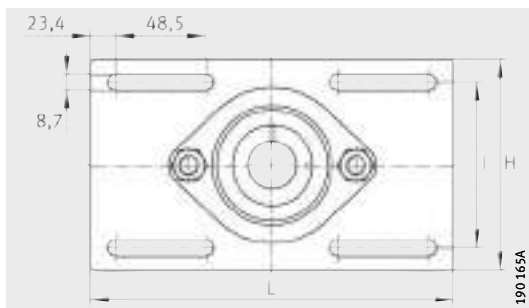

MSTU..-XL

**Dimension table** - Dimensions in mm

Designation			Mass m ≈ kg	Dimensions			
Unit	Housing <sup>1)</sup>	Radial insert ball bearing		d	H	J	L
<b>MSTU25-XL</b>	GEH52-MSTU	RAE25-XL-NPP-B	0,58	<b>25</b>	104,8	80,2	203,2
<b>MSTU30-XL</b>	GEH62-MSTU	RAE30-XL-NPP-B	0,84	<b>30</b>	114,3	89,2	203,2

<sup>1)</sup> Housing with Corrotect coating, suffix FA125.

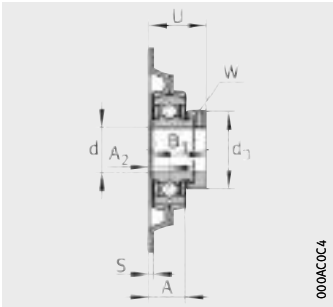

MSTU..-XL

						Width across flats W	Load carrying capacity			
							Bearing			Fatigue limit load $C_{ur}$ N
A	$A_2$	$B_1$	S	U	$d_3$ max.	dyn. $C_r$ N	stat. $C_{0r}$ N			
19	10,3	31	2	33,8	37,5	14 900	7 800	395	3 900	
21,1	12,1	35,8	2,5	37,8	44	20 700	11 300	570	3 900	





## Roller chain idler sprocket units Idler pulley units



# Roller chain idler sprocket units, idler pulley units

		Page
<b>Product overview</b>	Roller chain idler sprocket units, idler pulley units .....	336
<b>Features</b>	Roller chain idler sprocket units .....	337
	Idler pulley units.....	337
	Operating temperature .....	338
	Designation structure .....	338
	Material codes.....	338
<b>Design and safety guidelines</b>	Roller chain idler sprocket units .....	339
	Idler pulley units.....	340
<b>Accuracy</b>	Tolerances of radial insert ball bearing bore .....	341
	Radial internal clearance .....	341
<b>Dimension tables</b>	Roller chain idler sprocket units.....	342
	Idler pulley units.....	346



# Product overview **Roller chain idler sprocket units, idler pulley units**

## Roller chain idler sprocket units

Sprocket made from steel or sintered iron

KSR...-L0



KSR...-B0



Sprocket made from plastic

KSR...-L0...-22



## Idler pulley units

RSRA...-L0, RSRA...-K0



RSRB...-L0



RSRD...-L0



# Roller chain idler sprocket units, idler pulley units

**Features** Roller chain idler sprocket units and idler pulley units are robust, economical tensioning elements. These proven machine elements are available in various series and are suitable for a wide range of diverse applications.

**Roller chain idler sprocket units** Roller chain idler sprocket units are guidance and return units for roller bush chains and roller chains. They can compensate for chain stretch resulting from operation and give smoother system running under high loads and speeds.

The ready-to-fit units comprise sprockets and deep groove ball bearings or radial insert ball bearings. The sprockets are made from high strength steel, sintered iron or plastic (polyamide). Sprockets made from plastic give particularly smooth running and generate very little noise. Since the inner ring of the deep groove ball bearing is extended on both sides, no additional spacer rings are required.

In series KSR...-B0, the inner ring is located on the shaft by means of a locking collar. The bearing bore of this series has a plus tolerance. As a result, unmachined shafts up to tolerance class h9  $\text{Ⓢ}$  can be used under moderate loads and speeds.

**Sealing** The deep groove ball bearings are sealed on both sides.

**Lubrication** They are greased using a lithium soap grease to GA13 and are maintenance-free.

**Idler pulley units** Idler pulley units are tensioning systems for belt drives and idler units:

- They increase the wrap angle in belt drives and can therefore support higher power levels or allow smaller units to be used.
- They compensate for belt stretch resulting from operation.
- They allow shorter centre distances.
- They reduce the wear on the belt drive.

The ready-to-fit units comprise deep drawn, profiled sheet steel pulley halves riveted together and deep groove ball bearings. Pulleys of larger diameters are additionally welded together. A lead chamfer on the pulley profile prevents damage to the belt. Due to the sheet steel construction, the additional rotating masses and the unbalance masses generated are low.

Type A is suitable for vee belts, type B for flat, vee and round belts, type D for round belts, steel cables and hemp ropes.

**Sealing** The deep groove ball bearings are sealed on both sides.

**Lubrication** They are greased using a lithium soap grease to GA13 and are maintenance-free.



# Roller chain idler sprocket units, idler pulley units

## Operating temperature

Roller chain idler sprocket units with steel or sintered iron sprockets are suitable for operating temperatures from  $-20\text{ }^{\circ}\text{C}$  to  $+100\text{ }^{\circ}\text{C}$ . Temporary temperature peaks are possible up to  $+120\text{ }^{\circ}\text{C}$ .

Roller chain idler sprocket units with plastic sprockets are suitable for operating temperatures from  $-20\text{ }^{\circ}\text{C}$  to  $+80\text{ }^{\circ}\text{C}$ .

Idler pulley units are suitable for operating temperatures from  $-20\text{ }^{\circ}\text{C}$  to  $+100\text{ }^{\circ}\text{C}$ , limited by the grease and seal material. Temporary temperature peaks are possible up to  $+120\text{ }^{\circ}\text{C}$ .

## Designation structure

Units with the suffix L0 contain deep groove ball bearings with inner rings extended on both sides. Units with the suffix B0 contain radial insert ball bearings RAE...NPP with eccentric locking collars, *Figure 1*.

- ① Design (KSR or RSR)
- ② Bore diameter of bearing
- ③ Radial insert ball bearing with eccentric locking collar
- ④ Pitch  $p$  of sprocket in  $1/16''$ , code
- ⑤ Chain number in accordance with DIN ISO 606
- ⑥ Number of teeth  $z$
- ⑦ Material code, see table
- ⑧ Outside diameter of pulley
- ⑨ Inner ring extended on both sides

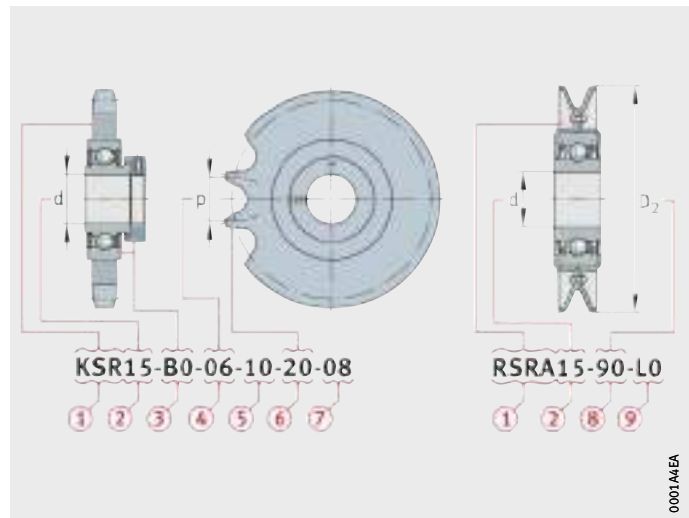

*Figure 1*  
Structure of the designation

## Material codes

The materials used for the sprockets are classified by means of material codes, see table.

## Classification of materials

Code	Material	Hardness to DIN EN ISO 6506-1	
		from	to
08	Sintered iron C 10	40 HBW	60 HBW
09	Sintered iron D 39	90 HBW	120 HBW
15	Steel St 52	–	–
16	Steel C 45	45 HRC	55 HRC
		Tooth flanks hardened	
22	Plastic PA	–	–

## Design and safety guidelines

### Roller chain idler sprocket units

The chapter Technical principles brings together the essential guidelines on the design of bearing arrangements, lubrication, mounting and dismantling and the operation of bearings, see page 32.

Roller chain idler sprocket units should always be mounted on the slack side of the chain, *Figure 2*.

The wrap angle on the idler sprocket unit should be selected such that at least three teeth are engaged simultaneously.

For grease lubrication, a grease with good adhesion characteristics should be used.

Roller chain idler sprocket units of bore  $d = 16$  mm are toleranced so that they can be fitted using fixing screws M16.



The contact pressure at the end face of the inner ring should not exceed  $10 \text{ N/mm}^2$ .

The minimum press-out force of the deep groove ball bearings is 700 N. This value must not be exceeded during operation.

The preload on the slack side should not be less than 1% of the tractive force on the taut side.

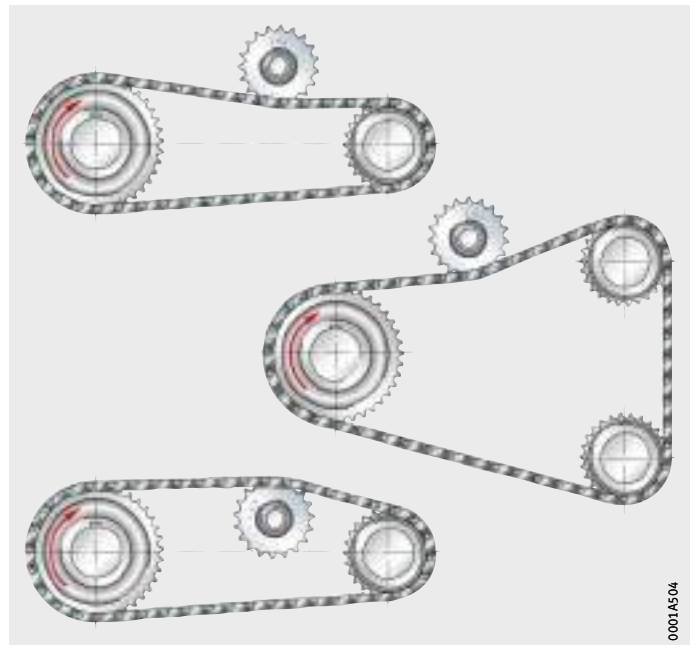

*Figure 2*  
Arrangement  
on slack side of chain drive

# Roller chain idler sprocket units, idler pulley units

## Idler pulley units

Idler pulley units should only be positioned on the slack side of the drive, *Figure 3*.

For normal loads, a light fit for the inner ring combined with axial clamping is sufficient.

If idler pulley units with a flat profile are to be used for tensioning via the back of a vee belt, check the suitability of the vee belt for this arrangement.



The permissible belt speed of 40 m/s must not be exceeded.

Check the permissible belt tension and operating life of the ball bearing for each individual application.

## Preload force

The following is an approximate guide value for the preload force  $S_v$  between the shafts:

- for flat belts  $S_v = 2$  to  $3 \times F_u$  (circumferential force)
- for vee belts  $S_v = 1,7$  to  $2,5 \times F_u$  (circumferential force).

## Checking of belt tension

Measure the speed ratio without load at low speed. Then measure the speed ratio at operating speed and under operating load. If the difference in speed due to slippage is  $> 2\%$ , retension the belt.

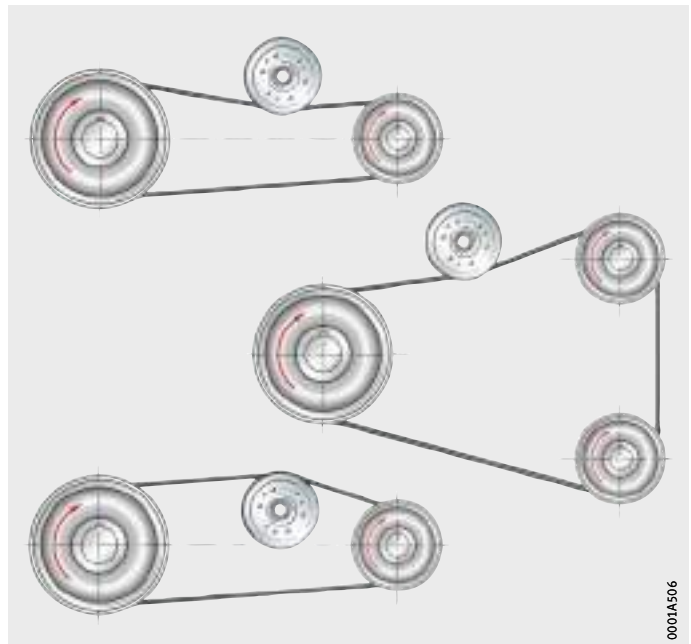

*Figure 3*  
Arrangement on slack side of belt  
drive

### Accuracy

In the case of idler pulley units for vee belts, the groove angles are slightly larger due to the small wrap than recommended according to DIN 2211 and DIN 2217.

### Tolerances of radial insert ball bearing bore

The tolerances of the inner ring bore of roller chain idler sprocket units KSR...-L0 are dependent on the diameter, see table.

The inner ring bore of roller chain idler sprocket units KSR...-B0 has a plus tolerance to allow easier mounting of the bearing, see dimension table.

### Bore tolerances

Series	Bore d mm	Deviation mm
KSR...-L0	16,2	+0,1 0
	20	0 -0,01
	25	0 -0,01
RSR...-L0	13	+0,08 -0,05
	15	+0,08 -0,05
	16	+0,26 +0,13
	17	0 -0,008
	20	0 -0,01
	25	0 -0,01

### Radial internal clearance

The radial internal clearance of mounted roller chain idler sprocket units corresponds to Group 5 in accordance with ISO 5753-1.



# Roller chain idler sprocket units

With extended inner ring

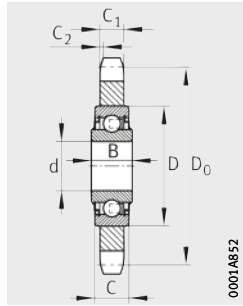

KSR..-L0

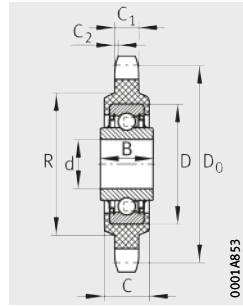

KSR..-L0..-22

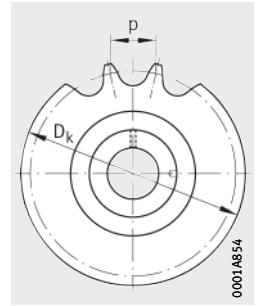

**Dimension table** - Dimensions in mm

Tooth set		Designation <sup>1)</sup>	Mass m ≈ kg	Dimensions										Chain to DIN ISO 606	
p <sup>2)</sup> "	z <sup>3)</sup>			d <sup>4)</sup>	C <sub>1</sub>	D <sub>0</sub>	D <sub>k</sub>	C <sub>2</sub> min.	D	B	C	R	ISO chain	ANSI chain	
3/8	20	<b>KSR16-L0-06-10-20-08</b>	0,14	16,2	5,2	60,9	65	0,8	40	18,3	12	-	x	-	
1/2	16	<b>KSR16-L0-08-10-16-08</b>	0,16	16,2	7	65,1	70,5	1,1	40	18,3	12	-	x	-	
		<b>KSR16-L0-08-10-16-15</b>	0,14	16,2	7	65,1	70,5	1,1	40	18,3	12	-	x	x	
		<b>KSR16-L0-08-10-16-22</b>	0,1	16,2	7	65,1	70,5	1,1	40	18,3	18,1	48	x	x	
	18	<b>KSR16-L0-08-10-18-08</b>	0,21	16,2	7	73,1	78,6	1,1	40	18,3	12	-	x	-	
		<b>KSR16-L0-08-10-18-09</b>	0,21	16,2	7	73,1	78,6	1,1	40	18,3	12	-	x	x	
		<b>KSR16-L0-08-10-18-16</b>	0,21	16,2	7	73,1	78,6	1,1	40	18,3	12	-	x	x	
		<b>KSR16-L0-08-10-18-22</b>	0,23	16,2	7	65,1	70,5	1,1	40	18,3	18	48	x	x	
5/8	14	<b>KSR16-L0-10-10-14-08</b>	0,21	16,2	8,7	71,3	78	1,3	40	18,3	12	-	x	x	
		<b>KSR16-L0-10-10-14-08-FA101</b>	0,21	16,2	8,7	71,3	78	1,3	40	18,3	12	-	x	x	
		<b>KSR16-L0-10-10-14-08-L091</b>	0,24	16,2	8,7	71,3	78	1,3	40	18,3	12	-	x	x	
	17	<b>KSR16-L0-10-10-17-08</b>	0,32	16,2	8,7	86,4	93,1	1,3	40	18,3	12	-	x	x	
		<b>KSR16-L0-10-10-17-09</b>	0,32	16,2	8,7	86,4	93,1	1,3	40	18,3	12	-	x	x	
		<b>KSR16-L0-10-10-17-22</b>	0,26	16,2	8,7	86,4	93,1	1,3	40	18,3	18	48	x	x	
19	<b>KSR16-L0-10-10-19-15-FA101</b>	0,45	16,2	9,15	96,4	103,5	1,5	40	18,3	12	-	x	-		
3/4	13	<b>KSR16-L0-12-10-13-08</b>	0,33	16,2	10,5	79,6	87	1,5	40	18,3	12	-	x	x	
		<b>KSR16-L0-12-10-13-16</b>	0,33	16,2	10,5	79,6	87	1,5	40	18,3	12	-	x	x	
	15	<b>KSR16-L0-12-10-15-08</b>	0,42	16,2	10,5	91,6	99,2	1,5	40	18,3	12	-	x	x	
		<b>KSR16-L0-12-10-15-09</b>	0,42	16,2	10,5	91,6	99,2	1,5	40	18,3	12	-	x	-	
		<b>KSR16-L0-12-10-15-22</b>	0,36	16,2	10,5	91,6	99,2	1,5	40	18,3	18	48	x	x	
	17	<b>KSR16-L0-12-10-17-15</b>	0,58	16,2	10,5	103,7	111,4	1,5	40	18,3	12	-	x	x	
		<b>KSR16-L0-12-10-17-16</b>	0,58	16,2	10,5	103,7	111,4	1,5	40	18,3	12	-	x	x	
	20	<b>KSR16-L0-12-10-20-15</b>	0,86	16,2	10,5	121,78	130	1,5	40	18,3	12	-	x	-	
	1	12	<b>KSR20-L0-16-10-12-15</b>	0,7	20	15,3	98,1	107,6	2	47	17,7	14	-	x	x
			<b>KSR20-L0-16-10-12-16</b>	0,7	20	15,3	98,1	107,6	2	47	17,7	14	-	x	-
1 1/4	9	<b>KSR25-L0-20-10-09-16</b>	0,8	25	17,6	92,8	103	2,5	52	21	15	-	x	x	
		<b>KSR25-L0-20-10-13-15</b>	1,6	25	17,6	132,7	144	2,5	52	21	15	-	x	x	

x suitable

1) Composition of designation, see page 338.

2) p = pitch.

3) z = number of teeth.

4) Tolerance of bore d, see page 341.

Inner rings of d = Ø16,2 are designed for fixing holes M16.





# Roller chain idler sprocket units

With eccentric locking collar

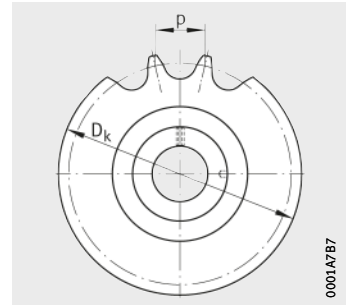
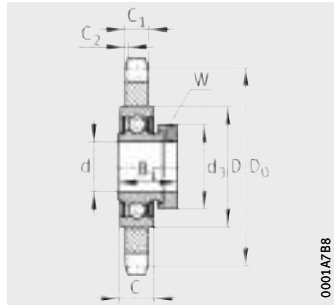

KSR...B0

**Dimension table** - Dimensions in mm

Tooth set		Designation <sup>1)</sup>	Mass m ≈ kg	Dimensions				
p <sup>2)</sup> "	z <sup>3)</sup>			d <sup>+0,018</sup> <sub>0</sub>	C <sub>1</sub>	D <sub>0</sub>	D <sub>k</sub>	C <sub>2</sub> min.
3/8	20	<b>KSR15-B0-06-10-20-08</b>	0,18	<b>15</b>	5,2	60,9	65	0,8
	1/2	16	<b>KSR15-B0-08-10-16-08</b>	0,21	<b>15</b>	7	65,1	70,5
		<b>KSR15-B0-08-10-16-08-AH01</b>	0,22	<b>15</b>	7	65,1	70,5	1,1
18		<b>KSR20-B0-08-10-18-08</b>	0,32	<b>20</b>	7	73,1	78,6	1,1
		<b>KSR20-B0-08-10-18-15</b>	0,32	<b>20</b>	7	73,1	78,6	1,1
19		<b>KSR25-B0-08-10-19-08</b>	0,29	<b>25</b>	7	77,1	82,5	1,1
5/8	14	<b>KSR15-B0-10-10-14-08</b>	0,26	<b>15</b>	8,7	71,3	78	1,3
	17	<b>KSR20-B0-10-10-17-15</b>	0,41	<b>20</b>	8,7	86,3	93,1	1,3
3/4	13	<b>KSR15-B0-12-10-13-08</b>	0,4	<b>15</b>	10,5	79,6	87	1,5
	15	<b>KSR20-B0-12-10-15-16</b>	0,47	<b>20</b>	10,5	91,6	99,2	1,5
1	10	<b>KSR20-B0-16-10-10-15</b>	0,5	<b>20</b>	15,3	82,3	89,4	2
	15	<b>KSR30-B0-16-10-15-15</b>	1,34	<b>30</b>	15,3	122,2	131	2

x suitable

<sup>1)</sup> Composition of designation, see page 338.

<sup>2)</sup> p = pitch.

<sup>3)</sup> z = number of teeth.

D	B <sub>1</sub>	C	d <sub>3</sub> max.	Width across flats	Chain to DIN ISO 606	
				W	ISO chain	ANSI chain
40	28,6	12	28,4	3	x	–
40	28,6	12	28,4	3	x	–
40	28,6	12	28,4	3	x	–
47	31	14	33	3	x	x
47	31	14	33	3	x	x
52	31	15	37,3	3	x	x
40	28,3	12	28,4	3	x	x
47	31	14	33	3	x	x
40	28,6	12	28,4	3	x	x
47	31	14	33	3	x	x
47	31	14	33	3	x	–
62	35,7	18	44	4	x	–



# Idler pulley units

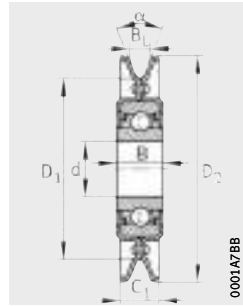

RSRA...-L0, RSRA...-K0  
Type A

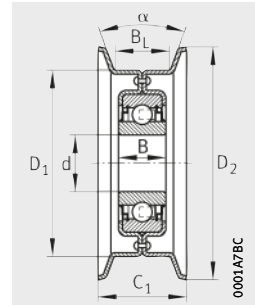

RSRB...-L0  
Type B

**Dimension table** - Dimensions in mm

Type	Designation	Mass m ≈ kg	Dimensions			
			d <sup>1)</sup>	D <sub>1</sub>	D <sub>2</sub>	B
<b>A</b>	<b>RSRA15-90-L0</b>	0,24	<b>15</b>	61,6	90	14,4
	<b>RSRA17-102-K0-AH01</b>	0,42	<b>17</b>	70,8	102	12
	<b>RSRA13-129-L0-L114<sup>4)</sup></b>	0,56	<b>13</b>	73,7	129	18,3
	<b>RSRA13-186-L0</b>	1,13	<b>13</b>	130,8	186	18,3
	<b>RSRA16-129-L0</b>	0,54	<b>16</b>	73,7	129	18,3
	<b>RSRA16-186-L0</b>	1,11	<b>16</b>	130,8	186	18,3
<b>B</b>	<b>RSRB13-117-L0</b>	0,5	<b>13</b>	101	117	18,3
	<b>RSRB13-159-L0</b>	0,8	<b>13</b>	139,7	159	18,3
	<b>RSRB15-92-L0</b>	0,31	<b>15</b>	76,2	92	14,4
	<b>RSRB16-117-L0</b>	0,48	<b>16</b>	101	117	18,3
	<b>RSRB16-159-L0</b>	0,78	<b>16</b>	139,7	159	18,3
	<b>RSRB16-222-L0</b>	1,45	<b>16</b>	203	222	18,3
<b>D</b>	<b>RSRD20-160-L0</b>	0,75	<b>20</b>	136,5	155,8	17,7
	<b>RSRD25-150-L0</b>	0,83	<b>25</b>	133	154	21

<sup>1)</sup> Tolerance of bore d, see table, page 341.

<sup>2)</sup> Vee belt size according to DIN 2215 (ISO 1081, ISO 4183, ISO 4184) and DIN 7753-1 (ISO 4184).

<sup>3)</sup> Basic load rating of bearing.

<sup>4)</sup> The bearing is greased with L114 (GA47).

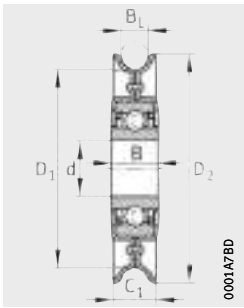

RSRD...-L0  
Type D

C <sub>1</sub>	B <sub>L</sub>	Angle	Vee belt size <sup>2)</sup>	Basic load ratings <sup>3)</sup>		Fatigue limit load
		α °		dyn. C <sub>r</sub> N	stat. C <sub>0r</sub> N	C <sub>ur</sub> N
20	12,4	32	8, 10, (12,5)	8 100	3 700	187
22,2	12,7	34	8, 10, (12,5)	9 600	4 750	239
32	22,1	32	13, 17, 20, 22	10 100	4 750	241
32	22,1	32	13, 17, 20, 22	10 100	4 750	241
32	22,1	32	13, 17, 20, 22	10 100	4 750	241
32	22,1	32	13, 17, 20, 22	10 100	4 750	241
36	25,4	10	–	10 100	4 750	241
36,5	25,4	10	–	10 100	4 750	241
31	22,2	10	–	8 100	3 700	187
36	25,4	10	–	10 100	4 750	241
36,5	25,4	10	–	10 100	4 750	241
50	38	10	–	10 100	4 750	241
17,5	13,5	–	–	13 600	6 600	335
24	17	–	–	14 900	7 800	395







## Radial insert ball bearings and housing units, corrosion-resistant

Radial insert ball bearings with Corrotect coating or  
in corrosion-resistant VA design  
Flake graphite cast iron and sheet steel housings  
High grade steel housings  
Plastic housings



# Radial insert ball bearings and housing units, corrosion-resistant

## **Radial insert ball bearings** ..... 352

**Corrosion-resistant VA design  
With Corrotect coating**

Corrosion-resistant radial insert ball bearings are designed for particularly humid environments. The bearings are available either with the anti-corrosion coating Corrotect or in the corrosion-resistant VA design.

Typical areas of application include the agricultural and mining sector, conveying equipment, textile, paper and woodworking machinery as well as machinery for the food and drinks industry.

---

## **Flake graphite cast iron housings** ..... 376

**With Corrotect coating**

Due to the anti-corrosion coating Corrotect, corrosion-resistant flake graphite cast iron housings are specially designed for humid environments.

The housings are single-piece components, have high load carrying capacity and are screw mounted to the adjacent construction by means of fixing holes.

The housings correspond in their design to standard housings and can be combined with end caps KASK.

---

## **Sheet steel housings** ..... 376

**Corrosion-resistant VA design**

The sheet steel housings are made from corrosion-resistant, austenitic chromium-nickel steel and are designed for moderate loads and lightweight constructions.

---

## **High grade steel housings** ..... 396

High grade steel housings are suitable for extremely high humidity, heavily contaminated water, salt spray and weakly alkaline and weakly acidic cleaning agents.

The housings do not have annular slots and cannot therefore be combined with end caps.

---

## **Plastic housings** ..... 426

Plastic housings made from the glass fibre reinforced material PBT are resistant not only to humidity but also to numerous chemical agents.

The housings are used in preference in foods and drinks industry. They have annular slots and are supplied with a closed end cap CC.



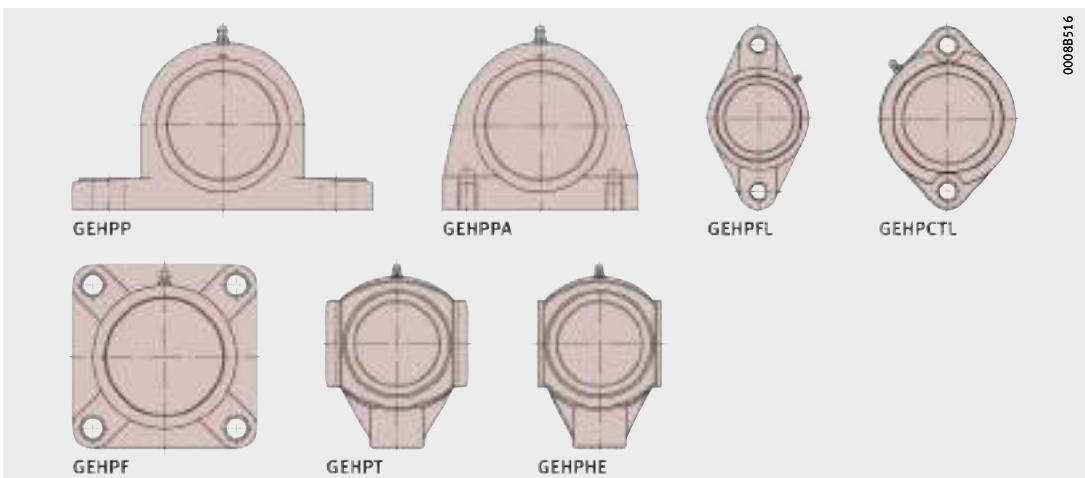
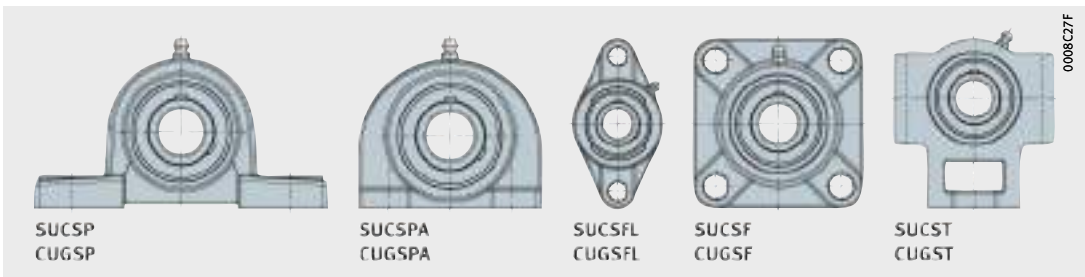
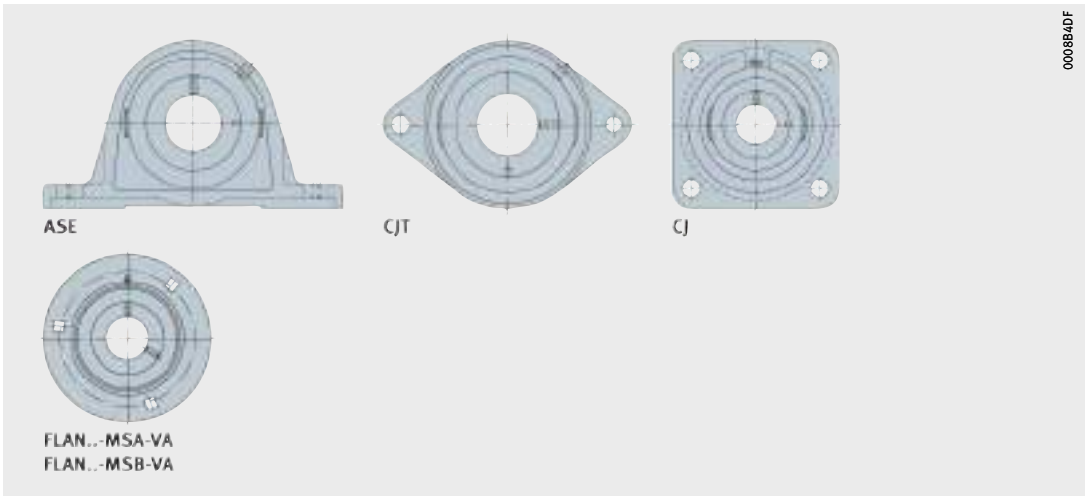
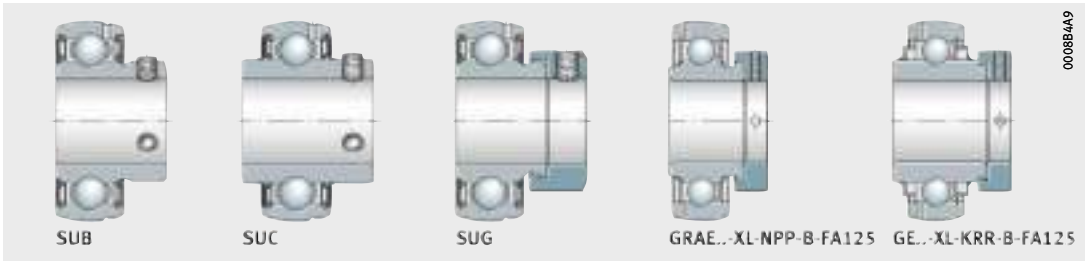



**Radial insert ball bearings,  
corrosion-resistant**

# Radial insert ball bearings, corrosion-resistant

	Page
<b>Matrix</b>	Features of radial insert ball bearings, comparison of series.... 354
<b>Product overview</b>	Radial insert ball bearings, corrosion-resistant..... 356
<b>Features</b>	X-life ..... 357
	Corrosion-resistant VA design or with Corrotect coating..... 357
	Radial insert ball bearings in corrosion-resistant VA design ..... 357
	Radial insert ball bearings with Corrotect coating ..... 360
	Sealing..... 362
	Suffixes..... 362
<b>Design and safety guidelines</b>	Compensation of static misalignments..... 363
	Minimum radial load ..... 363
	Speed limits for radial insert ball bearings ..... 363
	Shaft tolerances for radial insert ball bearings ..... 364
<b>Accuracy</b>	Standard tolerances of radial insert ball bearings..... 365
	Radial internal clearance of radial insert ball bearings..... 366
<b>Dimension tables</b>	Radial insert ball bearings, corrosion-resistant VA design, grub screws in inner ring..... 368
	Radial insert ball bearings, with Corrotect coating, with eccentric locking collar..... 374



**Features  
of radial insert ball bearings,  
comparison of series**

Series	Shaft diameter		Location
	mm		
	from	to	
<b>GRAE..-XL-NPP-B-FA125</b>	20	60	Eccentric locking collar
<b>GE..-XL-KRR-B-FA125</b>	20	50	Eccentric locking collar
<b>SUB</b>	20	50	Grub screws
<b>SUC</b>	12	50	Grub screws
<b>SUG</b>	20	50	Eccentric locking collar

- 1) Further guidelines must be observed, see section Lubrication, page 62.
- 2) Attention!  
Recommended operating temperature of bearing series.  
In the case of temperatures over +100 °C, relubrication must be carried out regularly.
- 3) Temporary temperature peaks are possible up to 120 °C.

Sealing	Compensation of misalignment	Internal clearance Group	Cage	Grease <sup>1)</sup>	Relubrication facility	Temperature <sup>2)</sup> °C		Comments	Dimension table Page
						from	to		
P	yes	3	PA66	GA47	yes	-20	+100 <sup>3)</sup>	Corrosion-resistant	374
R	yes	3	PA66	GA47	yes	-20	+100 <sup>3)</sup>	Corrosion-resistant	374
RSR	yes	3	Corrosion-resistant VA steel	FM222	yes	-35	+100	Corrosion-resistant	368
RSR	yes	3	Corrosion-resistant VA steel	FM222	yes	-35	+100	Corrosion-resistant, flinger shield	370
RSR	yes	3	Corrosion-resistant VA steel	FM222	yes	-35	+100	Corrosion-resistant	372



# Product overview Radial insert ball bearings, corrosion-resistant

**With grub screws in inner ring**  
Corrosion-resistant VA design



**With eccentric locking collar**  
Corrosion-resistant VA design



**With Corrotect coating**



# Radial insert ball bearings, corrosion-resistant

**Features** The radial insert ball bearings SUB, SUC and SUG as well as the radial insert ball bearings with the suffix FA125 are designed for corrosion-resistant bearing arrangements. They are therefore equally suitable for applications involving humidity, contaminated water, salt spray mist and for cleaning agents. Their classic areas of application include the agricultural, construction and mining sector, conveying equipment, textile, paper and woodworking machinery as well as machinery for the food and drink industry.

**X-life** Numerous sizes are supplied in the X-life design. These products are indicated in the dimension tables.

Radial insert ball bearings of X-life quality have, for example, lower roughness Ra and higher geometrical accuracy of the raceways than comparable designs that are not X-life. As a result, these bearings have higher load carrying capacity and longer rating life although their dimensions are identical. In certain applications, this means that a smaller bearing arrangement can be designed.

Radial insert ball bearings of X-life quality have an eccentric locking collar of an improved design and the quantity and distribution of the lubricant has been optimised. Housings ASE have additional crosspieces on the underside. For extreme requirements, the cage and seal material in the high and low temperature designs (suffix FA101) has been significantly improved in comparison with earlier versions.

## Corrosion-resistant VA design or with Corrotect coating

The bearings are available in the corrosion-resistant VA design or with the Corrotect thin film coating. They correspond in their design to single row deep groove ball bearings 62, are ready to fit, particularly easy to fit and allow robust, economical bearing arrangements with a long operating life. They are located on the shaft by means of grub screws in the extended inner ring or by means of an eccentric locking collar.

Operation even under difficult conditions is ensured by seals and greases that are matched to the application.

## Radial insert ball bearings in corrosion-resistant VA design

In the case of radial insert ball bearings SUB, SUC and SUG, the bearing rings, eccentric locking collar and rolling elements are made from high alloy, corrosion-resistant rolling bearing steel with an increased chromium and molybdenum content, material number 1.4125.

Sheet steel cages made from corrosion-resistant steel, material number 1.4301, retain and guide the rolling elements.



# Radial insert ball bearings, corrosion-resistant

## Media resistance

In the food industry in particular, the resistance of the material in relation to various cleaning agents is of increasing importance.

## Resistance to media

Medium	Concentration %	X5CrNi18-10 (1.4301)		440C (1.4125)	
		+20 °C	+80 °C	+20 °C	+80 °C
Hydrochloric acid HCl	0,1	+	+	–	–
	1	(+)	–	–	–
	18	–	–	–	–
Hydrofluoric acid HF	1	–	–	–	–
	5	– <sup>1)</sup>	–	– <sup>1)</sup>	–
Sulphuric acid H <sub>2</sub> SO <sub>4</sub>	1	+	–	–	–
	10	(+)	–	–	–
	96	+	(+)	–	–
Sulphurous acid H <sub>2</sub> SO <sub>3</sub>	1	+	+	–	–
Nitric acid HNO <sub>3</sub>	5	+	+	–	–
	25	+	+	+	(+)
	65	+	+	+	(+)
Phosphoric acid H <sub>3</sub> PO <sub>4</sub>	1	+	+	+	+
	10	+	+	(+)	+
	85	+	+	+	–
Formic acid HCOOH	5	+	+	–	–
	25	+	+	–	–
Acetic acid CH <sub>3</sub> COOH	5	+	+	+	–
	25	+	+	+	–
Citric acid	5	+	+	+	+
	25	+	+	–	–
Chloroacetic acid	5	+	+	(+)	–
Sodium chloride NaCl	10	+	+	(–)	(–)
Sea water	4	+	+	(–)	(–)
Distilled water	–	+	+	+	+
Ammonium hydroxide NH <sub>4</sub> OH	1	+	+	+	+
	10	+	+	+	+
Potassium hydroxide solution KOH	0,1	+	+	+	+
	1	+	+	+	+
	10	+	+	+	+
Sodium hypochlorite solution	1	+ <sup>1)</sup>	+	<sup>2)</sup>	(–)
Hydrogen peroxide H <sub>2</sub> O <sub>2</sub>	5	+	+	+	+

+ Resistant  
 (+) Moderately resistant  
 (–) Barely resistant  
 – Not resistant

<sup>1)</sup> Not tested.  
 Estimate generated from remaining test series.

<sup>2)</sup> Not tested.  
 No estimate possible.



**Location by means of corrosion-resistant VA grub screws**

The inner ring is located axially on the shaft by means of two corrosion-resistant VA grub screws, material number 1.4301, offset by 120°. This location method is suitable for bearing arrangements with a constant direction of rotation or, under low speed and load, for an alternating direction of rotation.

The grub screws are self-retaining and have a fine pitch thread with cup point for secure location of the bearings when taking account of the stated tightening torques, see table.

**Tightening torques for metric grub screws, corrosion-resistant VA design**

Width across flats W mm	Thread	Tightening torque <sup>1)</sup> M <sub>A</sub> Nm
2,5	M5	2,4
3	M6×0,75	3,9
4	M8×1	8,3
5	M10×1,25	16

<sup>1)</sup> The tightening torques are only valid for grub screws from Schaeffler.

**Location by means of corrosion-resistant VA eccentric locking collar**

The bearings are located on the shaft by a corrosion-resistant VA locking collar. They are thus particularly suitable for bearing arrangements with a constant direction of rotation or, under low speed and load, for an alternating direction of rotation.

The locking collar is preferably tightened in the direction of rotation and must be secured by means of a grub screw. This location method prevents damage to the shaft and can be easily loosened again.

**Sealing**

Single-piece seals RSR seal the radial insert ball bearings on both sides. Additional outer flinger shields made from corrosion-resistant steel, material number 1.4301, protect the seals against mechanical damage.

**Lubrication**

Initial greasing is carried out with an aluminium complex soap grease with food applications approval to NSF-H1 that is sufficient in many case for the entire operating life of the bearings. For relubrication, the outer rings have lubrication holes on their circumference.

**Operating temperature**

Radial insert ball bearings in the corrosion-resistant VA design are suitable for operating temperatures from -35 °C to +100 °C.



# Radial insert ball bearings, corrosion-resistant

## Radial insert ball bearings with Corrotect coating

The radial insert ball bearings GRAE..-XL-NPP-B-FA125 and GE..-XL-KRR-B-FA125 have a Corrotect thin film coating on all surfaces.

Plastic cages made from polyamide PA66 retain and guide the rolling elements.

### Anti-corrosion coating system Corrotect

The Corrotect thin film coating technology is an economical alternative to radial insert ball bearings with conventional anti-corrosion protection, see page 88. The thickness of the coating film is between 2 µm and 5 µm.

### Advantages of the anti-corrosion coating

The advantages of the Corrotect thin film coating are:

- All surfaces are protected against corrosion, including the machined surfaces of chamfers and radii.
- Rust beneath seals is prevented in the long term.
- Smaller spots that are damaged by the application and are bright as a result remain protected against corrosion by the cathodic protection effect.
- Operating life is significantly longer compared to uncoated parts due to the anti-corrosion protection.
- Uncoated bearings and housings are fully interchangeable with the coated versions of the same design.
- Bearings and housings made of corrosion-resistant rolling bearing steel are often no longer required.

### Media resistance

The resistance of the Corrotect thin film coating to various media must be noted, see table.



The use of the Corrotect thin film coating is not permitted for direct contact with foodstuffs.

### Resistance to media

Chemicals	Corrotect coating <sup>1)</sup>
Neutral, organic fluids (oil, brake fluid, petrol)	Resistant
Aqueous salt solutions in the neutral range $6 \leq \text{pH} \leq 8$ (table salt NaCl, seawater applications)	Conditionally resistant
Acidic liquids ( $\text{pH} \leq 6$ )	Not resistant
Alkaline liquids ( $\text{pH} \geq 8$ )	Not resistant
Oxidising substances (ozone, chlorine, peroxides, hypochlorides)	Not resistant

<sup>1)</sup> Valid for Corrotect coatings based on zinc and zinc alloy.



<b>Location by means of locking collar</b>	<p>The bearings are located on the shaft by a locking collar. They are thus particularly suitable for bearing arrangements with a constant direction of rotation or, under low speed and load, for an alternating direction of rotation.</p> <p>The locking collar is preferably tightened in the direction of rotation and must be secured by means of a grub screw. This location method prevents damage to the shaft and can be easily loosened again.</p>
<b>Sealing</b>	<p>Three-piece seals P or R seal the bearings on both sides. The NBR part is protected against mechanical damage by zinc plated sheet steel shields. In seals P, the seal lip is axially preloaded, in seals R it is radially preloaded.</p>
<b>Lubrication</b>	<p>Initial greasing is carried out using the grease GA47, which is sufficient in many cases for the entire operating life of the bearings. GA47 is a barium complex soap grease with a mineral oil base, see page 68.</p> <p>In order to increase the grease quantity, radial insert ball bearings with seals R have sheet steel shields that are angled and extended outwards. This provides more space for the grease. This extends the bearing operating life and the relubrication intervals. For relubrication, the outer rings have lubrication holes on their circumference.</p>
<b>Operating temperature</b>	<p>Corrosion-resistant radial insert ball bearings with a Corrotect coating are suitable for operating temperatures from <math>-20\text{ }^{\circ}\text{C}</math> to <math>+100\text{ }^{\circ}\text{C}</math>.</p> <p>Temporary temperature peaks are possible up to <math>+120\text{ }^{\circ}\text{C}</math>.</p>



# Radial insert ball bearings, corrosion-resistant

**Sealing** Seals for radial insert ball bearings are of a three-piece design. This concept offers, due to the rigidly rolled-in sheet steel washer, optimum seating in the bearing as well as concentric alignment of the seal lip to the inner ring.

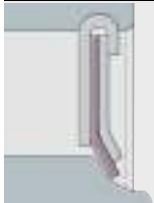
**Seal types**

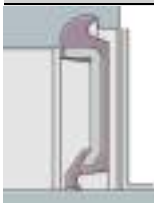
<b>P type seal (NPP), only for bearings with Corrotect coating</b>	
	<p>0008C5D4</p> <p>Two zinc-coated sheet steel washers (or in a corrosion-resistant VA design) with intermediate NBR part, seal lip axially preloaded.</p> <p>In order to protect the seal lip from mechanical damage, the outer sheet steel washer extends a considerable distance down towards the bearing inner ring.</p> <p>For use in narrow radial insert ball bearings with inner ring extended on one side.</p>
<b>R type seal (KRR), only for bearings with Corrotect coating</b>	
	<p>0008B8C1D</p> <p>Two zinc-coated sheet steel washers extended outwards and angled downwards with intermediate NBR part and radially preloaded seal lip. Improved protection against mechanical damage.</p> <p>Substantial grease reservoir due to the space between the extended and angled sheet steel washers.</p> <p>Used in radial insert ball bearings with inner ring extended on both sides.</p>
<b>RSR type seal with flinger shield in corrosion-resistant VA design</b>	
	<p>0008C5CB</p> <p>Single piece, sheet steel washer in corrosion-resistant VA design with vulcanised and radially preloaded seal lip made from NBR and additional flinger shield.</p>

**Suffixes** Suffixes for available designs, see table.

**Available designs**

Suffix	Description	Design
B	Bearing with spherical outside surface of outer ring	Standard
FA125	With Corrotect coating, corrosion-resistant	
KRR	Lip seals on both sides (seal R, three-piece)	
NPP	Lip seals on both sides (seal P, three-piece)	
FA107	Bearing with lubrication holes on the locating side	

## Design and safety guidelines

The chapter Technical principles brings together the essential guidelines on the design of bearing arrangements, lubrication, mounting and dismounting and the operation of bearings, see page 32.

## Compensation of static misalignments

Bearings with a spherical outer ring, fitted in housings with a concave bore, can compensate for static misalignment of the shaft, *Figure 1*.

For units with a lubrication groove in the housing and lubrication hole in the radial insert ball bearing, the following applies:

- Up to  $\pm 2,5^\circ$ , the units can be relubricated.
- Between  $\pm 2,5^\circ$  and  $\pm 5^\circ$ , the possibility of relubrication is dependent on the specific unit. Please contact us in this case.
- Over  $\pm 5^\circ$ , relubrication is no longer possible.



The units must not be used to support swivelling or tumbling motion.



*Figure 1*  
Compensation of static shaft misalignment

## Minimum radial load

In order to ensure slippage-free operation, the bearings must be subjected to a minimum radial load. This applies particularly in the case of high speeds and high accelerations. In continuous operation, a minimum radial load of the order of  $P \geq 0,01 \cdot C_r$  is necessary for ball bearings with cage.

## Speed limits for radial insert ball bearings

The speed limits are dependent on the load, the clearance between the bearing bore and shaft and the friction of the seals in the case of bearings with contact seals.

Guide values for the permissible speeds can be derived from the diagram, *Figure 2*, page 364.

In the case of load ratios  $C_r/P > 13$ , the speeds can be increased. For  $C_r/P < 5$ , location by means of a fit with a shaft roughness of Ra 0,3 is recommended, see page 100. For both types of applications, please contact us. In order to ensure slippage-free operation, the minimum radial load must be observed.



# Radial insert ball bearings, corrosion-resistant

Example of permissible speed calculation

Given:

- Shaft tolerance h6 ©
- Radial insert ball bearing GRAE30-XL-NPP-B-FA125
- Ball set 206
- Basic dynamic load rating  $C_r$  20 700 N
- Load P 1 300 N
- Sealing Seals P.

Required:

- Load ratio  $C_r/P = 20\,700\text{ N}/1\,300\text{ N}$   $C_r/P > 13$
- Permissible speed  $n \approx 4\,300\text{ min}^{-1}$ , Figure 2.

n = permissible speed  
 h5, h6, h9 = shaft tolerance  
 (this is subject to the envelope requirement ©)  
 $C_r/P$  = load ratio

- ① Ball set
- ② For d = 12 mm, 15 mm and 17 mm, identical ball set 203

Figure 2  
 Permissible speed for radial insert ball bearings with seal RSR

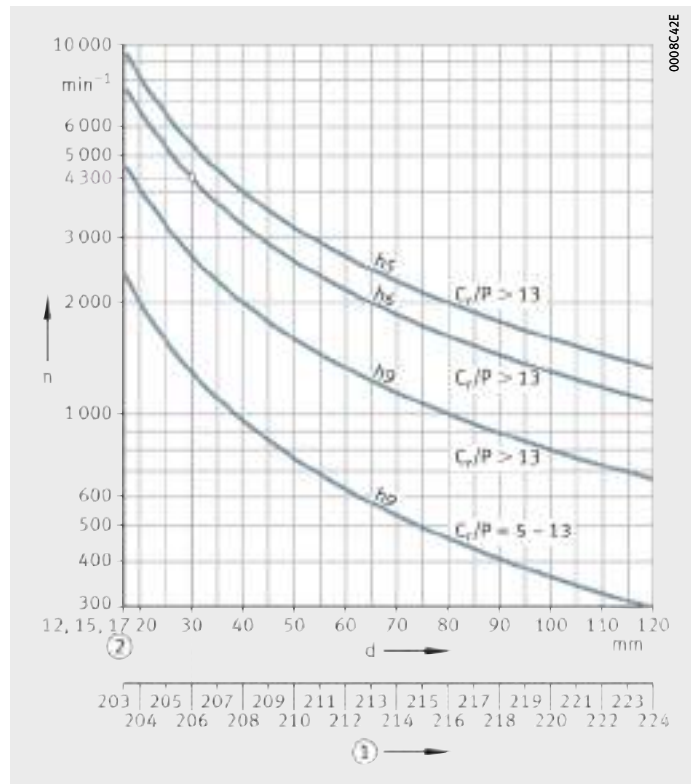

## Shaft tolerances for radial insert ball bearings

The permissible shaft tolerance is dependent on the speed and load. Shafts of the tolerance classes h6 © to h9 © can be used. Conventional drawn shafts will suffice for most applications.

## Accuracy Standard tolerances of radial insert ball bearings

### Tolerances of radial insert ball bearings, with Corrotect coating

The outside diameter of the bearings corresponds to tolerance class Normal in accordance with ISO 492, see tables. The inner ring bore has a plus tolerance to facilitate mounting of the bearing.

Inner ring				Outer ring			
Nominal dimension Bore d mm		Variation <sup>1)</sup> $t_{\Delta dmp}$ $\mu m$		Nominal dimension Outside diameter D mm		Variation <sup>2)</sup> $t_{\Delta Dmp}$ $\mu m$	
over	incl.	min.	max.	over	incl.	max.	min.
12	18	0	+18	30	50	0	-11
18	24	0	+18	50	80	0	-13
24	30	0	+18	80	120	0	-15
30	40	0	+18	120	150	0	-18
40	50	0	+18	150	180	0	-25
50	60	0	+18	180	250	0	-30
60	90	0	+25	-	-	-	-
90	120	0	+30	-	-	-	-

<sup>1)</sup> This corresponds to the arithmetic mean value derived from the largest and smallest diameters (measured using a two-point measuring device).

<sup>2)</sup> In the case of sealed bearings, the largest and smallest values of the outside diameter can deviate from the mean value by approx. 0,03 mm.

### Tolerances of radial insert ball bearings, corrosion-resistant VA design

Inner ring				Outer ring			
Nominal dimension Bore d mm		Variation <sup>1)</sup> $t_{\Delta dmp}$ $\mu m$		Nominal dimension Outside diameter D mm		Variation <sup>2)</sup> $t_{\Delta Dmp}$ $\mu m$	
over	incl.	min.	max.	over	incl.	max.	min.
18	24	0	+25	50	80	0	-13
24	30	0	+25	80	120	0	-13
30	40	0	+25	120	150	0	-13
40	50	0	+25	150	180	0	-13
50	60	0	+25	180	250	0	-13

<sup>1)</sup> This corresponds to the arithmetic mean value derived from the largest and smallest diameters (measured using a two-point measuring device).

<sup>2)</sup> In the case of sealed bearings, the largest and smallest values of the outside diameter can deviate from the mean value by approx. 0,03 mm.



## Radial insert ball bearings, corrosion-resistant

### Radial internal clearance of radial insert ball bearings

The radial internal clearance of most series is Group 3 to ISO 5753-1 and is thus larger than for normal deep groove ball bearings, see table and page 146.

The larger internal clearance allows better support of angular misalignment and shaft deflection.

### Radial internal clearance

Bore d mm		Radial internal clearance							
		Group N μm		Group 3 μm		Group 4 μm		Group 5 μm	
over	incl.	min.	max.	min.	max.	min.	max.	min.	max.
2,5	6	2	13	8	23	–	–	–	–
6	10	2	13	8	23	14	29	20	37
10	18	3	18	11	25	18	33	25	45
18	24	5	20	13	28	20	36	28	48
24	30	5	20	13	28	23	41	30	53
30	40	6	20	15	33	28	46	40	64
40	50	6	23	18	36	30	51	45	73
50	65	8	28	23	43	38	61	55	90
65	80	10	30	25	51	46	71	65	105
80	100	12	36	30	58	53	84	75	120
100	120	15	41	36	66	61	97	90	140
120	140	18	48	41	81	71	114	105	160
140	160	18	53	46	91	81	130	120	180





# Radial insert ball bearings with grub screws in inner ring

Spherical outer ring  
Corrosion-resistant VA design

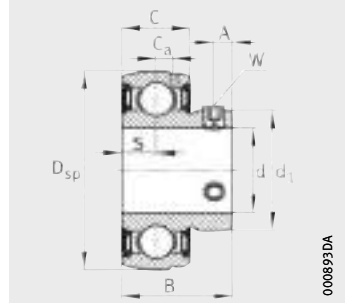

SUB

**Dimension table** - Dimensions in mm

Designation <sup>1)2)</sup>	Mass m ≈ kg	Dimensions					
		d	D <sub>sp</sub>	C	B	S	d <sub>1</sub>
<b>SUB204</b>	0,14	<b>20</b>	47	16	26	8	29,05
<b>SUB205</b>	0,17	<b>25</b>	52	17	28	8,5	34,03
<b>SUB206</b>	0,26	<b>30</b>	62	19	30,5	9,5	40,31
<b>SUB207</b>	0,41	<b>35</b>	72	20	35,45	10	47,4
<b>SUB208</b>	0,52	<b>40</b>	80	21	39,45	10,5	52,83
<b>SUB209</b>	0,6	<b>45</b>	85	22	41,5	11	57,3
<b>SUB210</b>	0,67	<b>50</b>	90	23	43,5	11,5	62,92

<sup>1)</sup> Speed limits for radial insert ball bearings, see page 363.

<sup>2)</sup> Lubrication groove and two lubrication holes in the outer ring.

<sup>3)</sup> Factor  $f_0$  for determining equivalent bearing load, see table, page 40.

		Width across flats W	Basic load ratings		Fatigue limit load C <sub>ur</sub> N	Factor <sup>3)</sup> f <sub>0</sub>
C <sub>a</sub>	A		dyn. C <sub>r</sub> N	stat. C <sub>0r</sub> N		
4	4,5	2,5	12 300	6 300	300	13,1
4,15	5	2,5	13 400	7 500	360	13,8
5	5,8	3	18 700	10 700	510	13,8
5,7	6,1	3	24 600	14 600	700	13,8
5,9	8	4	31 500	18 900	910	14
6,5	8	4	31 500	19 400	930	14,3
6,5	9	5	33 500	22 100	1 060	14,3



# Radial insert ball bearings with grub screws in inner ring

Spherical outer ring  
Corrosion-resistant VA design  
With extended inner ring

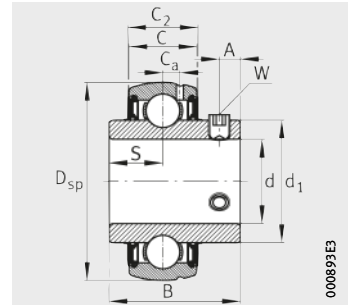

SUC

**Dimension table** - Dimensions in mm

Designation <sup>1)</sup>	Mass m ≈ kg	Dimensions					
		d	D <sub>sp</sub>	C	C <sub>2</sub> max.	B	S
<b>SUC201</b> <sup>3)</sup>	0,11	<b>12</b>	40	12	12,6	25	9,6
<b>SUC202</b> <sup>3)</sup>	0,1	<b>15</b>	40	12	12,6	25	9,6
<b>SUC203</b> <sup>3)</sup>	0,08	<b>17</b>	40	12	12,6	25	9,6
<b>SUC204</b> <sup>4)</sup>	0,16	<b>20</b>	47	16	16,6	31	12,7
<b>SUC205</b> <sup>4)</sup>	0,2	<b>25</b>	52	17	17,6	34,1	14,3
<b>SUC206</b> <sup>4)</sup>	0,31	<b>30</b>	62	19	19,6	38,1	15,9
<b>SUC207</b> <sup>4)</sup>	0,47	<b>35</b>	72	20	20,6	42,9	17,5
<b>SUC208</b> <sup>4)</sup>	0,62	<b>40</b>	80	21	21,6	49,2	19
<b>SUC209</b> <sup>4)</sup>	0,67	<b>45</b>	85	22	22,6	49,2	19
<b>SUC210</b> <sup>4)</sup>	0,78	<b>50</b>	90	23	23,6	51,6	19

<sup>1)</sup> Speed limits for radial insert ball bearings, see page 363.

<sup>2)</sup> Factor  $f_0$  for determining equivalent bearing load, see table, page 40.

<sup>3)</sup> Two lubrication holes in the outer ring.

<sup>4)</sup> Lubrication groove and two lubrication holes in the outer ring.

			Width across flats W	Basic load ratings		Fatigue limit load C <sub>ur</sub> N	Factor <sup>2)</sup> f <sub>0</sub>
d <sub>1</sub>	C <sub>a</sub>	A		dyn. C <sub>r</sub> N	stat. C <sub>0r</sub> N		
23,9	3,4	4	2,5	9 200	4 550	218	13,1
23,9	3,4	4	2,5	9 200	4 550	218	13,1
23,9	3,4	4	2,5	9 200	4 550	218	13,1
29,05	4	5	2,5	12 300	6 300	300	13,1
34,03	4,15	5	2,5	13 400	7 500	360	13,8
40,31	5	6	3	18 700	10 700	510	13,8
47,4	5,7	6,5	3	24 600	14 600	700	13,8
52,83	5,9	8	4	31 500	18 900	910	14
57,3	6,5	8	4	31 500	19 400	930	14,3
62,92	6,5	9	5	33 500	22 100	1 060	14,3



# Radial insert ball bearings with eccentric locking collar

Spherical outer ring  
Corrosion-resistant VA design

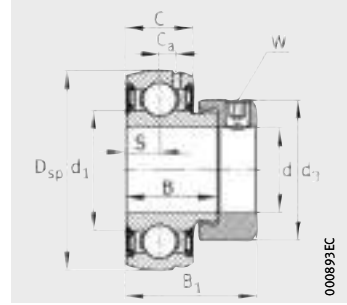

SUG

**Dimension table** - Dimensions in mm

Designation <sup>1)2)</sup>	Mass m ≈ kg	Dimensions					
		d	D <sub>sp</sub>	C	B	S	d <sub>1</sub>
<b>SUG204</b>	0,17	<b>20</b>	47	16	21,9	8	29,05
<b>SUG205</b>	0,2	<b>25</b>	52	17	22,4	8,5	34,03
<b>SUG206</b>	0,31	<b>30</b>	62	19	24,3	9,5	40,31
<b>SUG207</b>	0,51	<b>35</b>	72	20	25,9	10	47,4
<b>SUG208</b>	0,6	<b>40</b>	80	21	30,2	11	52,83
<b>SUG209</b>	0,7	<b>45</b>	85	22	30,2	11	57,3
<b>SUG210</b>	0,77	<b>50</b>	90	23	30,7	11	62,92

- 1) Speed limits for radial insert ball bearings, see page 363.
- 2) Lubrication groove and two lubrication holes in the outer ring.
- 3) Factor  $f_0$  for determining equivalent bearing load, see table, page 40.

			Width across flats W	Basic load ratings		Fatigue limit load C <sub>ur</sub> N	Factor <sup>3)</sup> f <sub>0</sub>
C <sub>a</sub>	B <sub>1</sub>	d <sub>3</sub> max.		dyn. C <sub>r</sub> N	stat. C <sub>0r</sub> N		
4	31,5	33	3	12 300	6 300	300	13,1
4,15	32	37,5	3	13 400	7 500	360	13,8
5	36,3	44	4	18 700	10 700	510	13,8
5,7	39,5	55	5	24 600	14 600	700	13,8
5,9	43,8	58	5	31 500	18 900	910	14
6,5	43,8	63	5	31 500	19 400	930	14,3
6,5	44,3	69	5	33 500	22 100	1 060	14,3



# Radial insert ball bearings with eccentric locking collar

Spherical outer ring  
With Corrotect coating

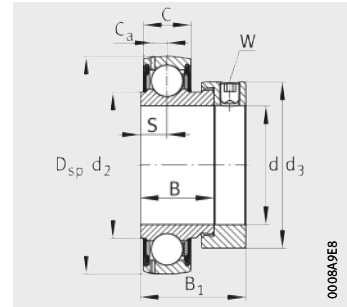

GRAE...XL-NPP-B-FA125



**Dimension table** - Dimensions in mm

Designation <sup>1)</sup>	Mass m ≈ kg	Dimensions						
		d	D <sub>sp</sub>	C	C <sub>2</sub>	B	S	d <sub>1</sub>
GRAE20-XL-NPP-B-FA125	0,16	20	47	14	–	21,4	7,5	–
GE20-XL-KRR-B-FA125	0,19	20	47	14	16,6	34,1	17,1	27,6
GRAE25-XL-NPP-B-FA125	0,19	25	52	15	–	21,4	7,5	–
GE25-XL-KRR-B-FA125	0,25	25	52	15	16,7	34,9	17,5	33,8
GRAE30-XL-NPP-B-FA125	0,32	30	62	18	–	23,8	9	–
GE30-XL-KRR-B-FA125	0,39	30	62	18	20,7	36,5	18,3	40,2
GRAE35-XL-NPP-B-FA125	0,48	35	72	19	–	25,4	9,5	–
GE35-XL-KRR-B-FA125	0,55	35	72	19	22,5	37,7	18,8	46,8
GRAE40-XL-NPP-B-FA125	0,62	40	80	21	–	30,2	11	–
GE40-XL-KRR-B-FA125	0,73	40	80	21	23,5	42,9	21,4	52,3
GRAE45-XL-NPP-B-FA125	0,69	45	85	22	–	30,2	11	–
GE45-XL-KRR-B-FA125	0,83	45	85	22	26,4	42,9	21,4	57,9
GRAE50-XL-NPP-B-FA125	0,77	50	90	22	–	30,2	11	–
GE50-XL-KRR-B-FA125	0,99	50	90	22	26,4	49,2	24,6	62,8
GRAE60-XL-NPP-B-FA125	1,4	60	110	24	–	37,1	13,5	–

<sup>1)</sup> Speed limits for radial insert ball bearings, see page 363.

<sup>2)</sup> Factor  $f_0$  for determining equivalent bearing load, see table, page 40.



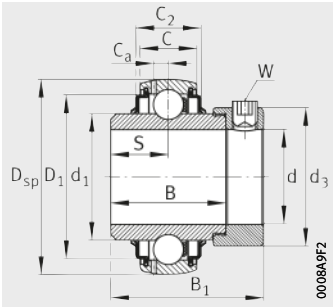

GE..-XL-KRR-B-FA125

					Width across flats W	Basic load ratings		Fatigue limit load C <sub>ur</sub> N	Factor <sup>2)</sup> f <sub>0</sub>
d <sub>2</sub>	D <sub>1</sub>	C <sub>a</sub>	B <sub>1</sub>	d <sub>3</sub> max.		dyn. C <sub>r</sub> N	stat. C <sub>0r</sub> N		
26,9	–	4	31	33	3	13 600	6 600	335	13,1
–	37,4	4	43,7	33	3	13 600	6 600	335	13,1
30,5	–	3,9	31	37,5	3	14 900	7 800	395	13,8
–	42,5	4,1	44,5	37,5	3	14 900	7 800	395	13,8
37,4	–	4,7	35,8	44	4	20 700	11 300	570	13,8
–	52	4,7	48,5	44	4	20 700	11 300	570	13,8
44,6	–	5,6	39	55	5	27 500	15 300	770	13,8
–	60,3	5,6	51,3	55	5	27 500	15 300	770	13,8
49,4	–	6,4	43,8	58	5	34 500	19 800	1 010	14
–	68,3	6,4	56,5	58	5	34 500	19 800	1 010	14
54,3	–	6,4	43,8	63	5	34 500	20 400	1 030	14,3
–	72,3	6,4	56,5	63	5	34 500	20 400	1 030	14,3
59,4	–	6,9	43,8	69	5	37 500	23 200	1 180	14,3
–	77,3	6,9	62,8	69	5	37 500	23 200	1 180	14,3
72	–	7,2	53,1	84	5	56 000	36 000	1 820	14,3





## Flake graphite cast iron or sheet steel housing units, corrosion-resistant





With Corrotect coating  
Corrosion-resistant VA design

# Flake graphite cast iron or sheet steel housing units, corrosion-resistant





	Page
<b>Matrix</b>	Possible combinations of radial insert ball bearings with flake graphite cast iron or sheet steel housings, corrosion-resistant ..... 378
<b>Product overview</b>	Flake graphite cast iron or sheet steel housing units, corrosion-resistant ..... 380
<b>Features</b>	X-life ..... 381 Housings with integral radial insert ball bearing ..... 381 Units with flake graphite cast iron housing ..... 382 Units with sheet steel housing ..... 382 Operating temperature ..... 383 Suffixes ..... 384
<b>Design and safety guidelines</b>	Compensation of static misalignments ..... 384 Speed limits for radial insert ball bearings ..... 385 Radial load carrying capacity ..... 385 Axial load carrying capacity ..... 385 Design of adjacent construction ..... 385 Bearing end caps ..... 386
<b>Accuracy</b>	Dimensional tolerances ..... 387
<b>Dimension tables</b>	Plummer block housing units, flake graphite cast iron housing, with Corrotect coating ..... 388 Two-bolt flanged housing units, flake graphite cast iron housing, oval version, with Corrotect coating ..... 390 Three-bolt flanged housing units, sheet steel housing, round version, corrosion-resistant VA design ..... 392 Four-bolt flanged housing units, flake graphite cast iron housing, square version, with Corrotect coating ..... 394



Possible combinations  
Radial insert ball bearings  
with flake graphite cast iron or  
sheet steel housings,  
corrosion-resistant

<b>Radial insert ball bearing</b>		Housing
		Plummer block housing
		
Designation		<b>ASE</b>
Shaft diameter d		
<b>GRAE..-XL-NPP-B-FA125</b> 20 mm – 60 mm		<b>PASE..-XL-N-FA125</b> page 388
<b>GE..-XL-KRR-B-FA125</b> 20 mm – 50 mm		<b>RASE..-XL-N-FA125</b> page 388
<b>SUC</b> 12 mm – 30 mm		Available by agreement

Catalogue range, dimension table, see pages indicated.  
Other dimensions and combinations available by agreement.

Two-bolt flanged housing	Three-bolt flanged housing		Four-bolt flanged housing
			
<b>CJT</b>	<b>FLAN..-MSB-VA</b> (2 pieces)	<b>FLAN..-MSA-VA</b> <b>FLAN..-MSB-VA</b>	<b>CJ</b>
<b>PCJT..-XL-N-FA125</b> page 390	Available by agreement	Available by agreement	<b>PCJ..-XL-N-FA125</b> page 394
<b>RCJT..-XL-N-FA125</b> page 390	Available by agreement	Available by agreement	<b>RCJ..-XL-N-FA125</b> page 394
Available by agreement	<b>RRY..-VA</b> page 392	<b>GRRY..-VA</b> page 392	Available by agreement



# Product overview **Flake graphite cast iron or sheet steel housing units, corrosion-resistant**

## **Flake graphite cast iron housing units**

With Corrotect coating

PASE..-XL-N-FA125,  
RASE..-XL-N-FA125



PCJT..-XL-N-FA125,  
RCJT..-XL-N-FA125



PCJ..-XL-N-FA125,  
RCJ..-XL-N-FA125



## **Sheet steel housing units**

Corrosion-resistant VA design

GRRY..-VA,  
RRY..-VA



# Flake graphite cast iron or sheet steel housing units, corrosion-resistant

**Features** Corrosion-resistant flake graphite cast iron and sheet steel housings are available as plummer block and flanged housing units. The areas of application of the housings correspond to that of the radial insert ball bearings. They are suitable where humidity, contaminated water, salt spray mist, weakly alkaline or weakly acidic cleaning agents are present.

**Further information** Further information on Corrotect

- TPI 64, Corrosion-resistant Products
- TPI 67, Special Coating Corrotect, Anti-corrosion Protection for Rolling Bearings and Precision Components
- TPI 186, Higher Performance Capacity Through the Use of Coatings, Coated Rolling Bearings and Precision Components, functional coatings for Automotive and Industrial applications
- Download and ordering: <http://medien.schaeffler.de>.

**X-life** Numerous sizes are supplied in the X-life design. These products are indicated in the dimension tables.

Radial insert ball bearings of X-life quality have, for example, lower roughness Ra and higher geometrical accuracy of the raceways than comparable designs that are not X-life. As a result, these bearings have higher load carrying capacity and longer rating life although their dimensions are identical. In certain applications, this means that a smaller bearing arrangement can be designed.

Radial insert ball bearings of X-life quality have an eccentric locking collar of an improved design and the quantity and distribution of the lubricant has been optimised. Housings ASE have additional crosspieces on the underside. For extreme requirements, the cage and seal material in the high and low temperature designs (suffix FA101) has been significantly improved in comparison with earlier versions.

## Housings with integral radial insert ball bearing

The units are ready-to-fit and comprise INA sheet steel or INA flake graphite cast iron housings in which INA radial insert ball bearings are integrated, see page 357.

Due to the spherical outside surface of the bearing outer ring and the concave housing bore, housing units can compensate for static angular misalignment of the shaft.

The units are used predominantly as locating bearings, but are also suitable as non-locating bearings under low loads and speeds.

The housings are screw mounted on the adjacent construction. Less stringent tolerances are sufficient for the screw mounting surfaces.



# Flake graphite cast iron or sheet steel housing units, corrosion-resistant

## Units with flake graphite cast iron housing

Cast iron units are available as plummer block housing units PASE...XL-N-FA125 and RASE...XL-N-FA125, as well as flanged housing units PCJT...XL-N-FA125, RCJT...XL-N-FA125, PCJ...XL-N-FA125 and RCJ...XL-N-FA125.

The housings and radial insert ball bearings have a Corrotect coating and the suffix FA125. The housings are single-piece components, have high load carrying capacity and are screw mounted to the adjacent construction by means of fixing holes. For location, screws in accordance with DIN EN ISO 4762 are suitable.



In order to ensure function and reliability under all operating conditions, the bearings and housings are matched to each other with a defined swivel moment after mounting.

All catalogue cast iron units have a mean swivel moment (as standard); further designs with a smaller or greater swivel moment, depending on their application, are available by agreement.

### Lubrication

For the relubrication of radial insert ball bearings, the housing bore has a lubrication groove and a lubrication hole suitable for conventional taper type lubrication nipples to DIN 71412. When the housing units are supplied, a taper type lubrication nipple with a thread M6 is already fitted.

## Units with sheet steel housing

These units are available in their preferred versions as series GRRY...VA and RRY...VA.

The units comprise radial insert ball bearings in a corrosion-resistant VA design, see page 357, and two-piece sheet steel housings made from corrosion-resistant steel, material number 1.4301. The units have the suffix VA.

The units are designed for moderate loads and lightweight constructions.



In order to ensure function and reliability under all operating conditions, the bearings and housings are matched to each other with a defined swivel moment after mounting.

The swivel moment can be requested from Schaeffler.

### Lubrication







GRRY can be relubricated via a lubrication nipple.

### Further possible combinations

In addition to the sheet steel housings in corrosion-resistant VA design, sheet steel housings with Corrotect coating are also possible in combination with the radial insert ball bearing GRAE...XL-NPP-B-FA125. Housings and bearings in the following possible combinations must be ordered separately, see table.

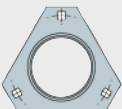

## Possible combinations for available diameters

Combination Radial insert ball bearing with sheet steel housing <sup>1)</sup>		<b>GRAE...XL-NPP-B-FA125</b>  00081619	
		mm	
		min.	max.
Plummer block housing			
<b>GEH...PBS-FA125</b>	 190 941A	20	40
<b>GEH...BT-FA125</b>	 190 942A	20	30
Two-bolt flanged housing			
<b>FLAN...MST-FA125</b> (2 pieces)	 0008C5DD	20	40
Three-bolt flanged housing			
<b>FLAN...MSB-FA125</b> (2 pieces)	 0008C5E6	20	55
<b>FLAN...MSA-FA125<sup>2)</sup></b> <b>FLAN...MSB-FA125<sup>2)</sup></b>	 0008C5E6	25	45
<b>FLAN...MSTR-FA125</b>	 0008C5EF	20	35

<sup>1)</sup> For housing code and bearing bore, see table.

<sup>2)</sup> Relubrication facility.

## Housing code and bearing bore

Housing code	47	52	62	72	80	85	90	100
Bearing bore $\varnothing d$ mm	20	25	30	35	40	45	50	55

## Operating temperature

Housing units with bearing end caps are suitable for operating temperatures from  $-20\text{ }^{\circ}\text{C}$  to  $+80\text{ }^{\circ}\text{C}$ .

Housing units without bearing end caps are suitable for operating temperatures from  $-20\text{ }^{\circ}\text{C}$  to  $+100\text{ }^{\circ}\text{C}$ . Temporary temperature peaks are possible up to  $+120\text{ }^{\circ}\text{C}$ .

Sheet steel housing units in the corrosion-resistant VA design without bearing end caps are suitable for operating temperatures from  $-35\text{ }^{\circ}\text{C}$  to  $+100\text{ }^{\circ}\text{C}$ .



# Flake graphite cast iron or sheet steel housing units, corrosion-resistant

## Suffixes

Suffixes for available designs, see table.

### Available designs

Suffix	Design	Design
FA125	With Corrotect coating, corrosion-resistant	Standard
VA	Made from corrosion-resistant steel	

## Design and safety guidelines

The chapter Technical principles brings together the essential guidelines on the design of bearing arrangements, lubrication, mounting and dismounting and the operation of bearings, see page 32.

Due to their versatile characteristics, INA housing units can be easily used in almost all industrial sectors.



It is always and fundamentally the responsibility of the designer of a machine to ensure that a malfunction of housing units cannot be hazardous to persons. An unplanned stoppage of the machine should not cause major disruptions in operation. In both cases, it is therefore essential that you contact us before design work is carried out.

## Compensation of static misalignments

Bearings with a spherical outer ring, fitted in housings with a concave bore, can compensate for static misalignment of the shaft, *Figure 1*.

For units with a lubrication groove in the housing and lubrication hole in the radial insert ball bearing, the following applies:

- Up to  $\pm 2,5^\circ$ , the units can be relubricated.
- Between  $\pm 2,5^\circ$  and  $\pm 5^\circ$ , the possibility of relubrication is dependent on the specific unit. Please contact us in this case.
- Over  $\pm 5^\circ$ , relubrication is no longer possible.



The units must not be used to support swivelling or tumbling motion.



*Figure 1*  
Compensation of static shaft misalignment

## Speed limits for radial insert ball bearings

The speed limits are dependent on the load, the clearance between the bearing bore and shaft and the friction of the seals, see page 363.

## Radial load carrying capacity

Flake graphite cast iron housings can support the same radial loads as the radial insert ball bearings fitted.

Sheet steel housings are suitable for moderate loads. The permissible radial load carrying capacity  $C_{0rG}$  of sheet steel housings is given in the dimension tables.

The static load carrying capacity  $C_{0r}$  of the radial insert ball bearings is stated in the dimension tables.



Where shock loads are present, appropriate safety factors must be applied. In this case, please contact us.

## Axial load carrying capacity

The axial operating load of the unit must not exceed the axial load carrying capacity of the housing.

The axial load carrying capacity of flake graphite cast iron housings is  $C_{0aG} = 0,5 \cdot C_{0r}$

The permissible axial load carrying capacity of sheet steel housings for three-bolt flanged housing units RRY..-VA and GRRY..-VA is  $C_{0aG} = 0,5 \cdot C_{0rG}$ .

## Design of adjacent construction

The permissible shaft tolerance is dependent on the speed, load and the radial insert ball bearing fitted. Shafts of the tolerance classes h6  $\oplus$  to h9  $\oplus$  can be used. Conventional drawn shafts will suffice for most applications.

## Screw mounting surfaces

Recommendations for the screw mounting surfaces are as follows:

- roughness of the screw mounting surface max. Ra 12,5 (Rzmax 63)
- geometrical and positional tolerance 0,04/100 concave, spherical not permissible.
- In the event of high loads occurring parallel to the mounting surface of plummer block housing units (in the case of cast iron housings with long base), the use of additional dowel pins to DIN EN ISO 8752 is recommended. In this case, through holes (see centre punch mark for housing ASE) must be applied, see *Figure 1*, page 129.

## Fixing screws

The screw connection should be designed in accordance with VDI 2230; friction coefficient  $\mu = 0,12$  (90%).

Screws of grade 8.8 or better can be used for fixing.

The maximum tightening torques applicable to this screw grade must not be exceeded even if screws of a higher grade are used.

In principle, we recommend that the screw connection should only be tightened to 70% of the values stated in the standard.

For fixing, hexagonal socket head screws in accordance with DIN EN ISO 4762 or hexagonal socket head screws with a coarse pitch full thread in accordance with DIN EN ISO 4017 should be used. The screws should be combined as a minimum with a washer in accordance with DIN EN ISO 7089 or DIN EN ISO 7090.

Screws and accessories for location are not included in the delivery.

All screws and other accessories used for location of the units GRRY..-VA and RRY..-VA should be in the corrosion-resistant VA design.



# Flake graphite cast iron or sheet steel housing units, corrosion-resistant

## Bearing end caps

The ends of shafts can be covered using bearing end caps made from acrylonitrile styrene acrylate copolymer (ASA), see table and *Figure 2*. The caps are suitable for temperatures from  $-20\text{ }^{\circ}\text{C}$  to  $+80\text{ }^{\circ}\text{C}$ . They protect against injury due to rotating shafts and also protect the bearings against contamination.

For location of the caps, housings with the suffix N have an annular slot on the entry side, see page 134.

The series for which end caps are supplied are indicated in the dimension tables. Bearing end caps are accessories and must always be ordered separately.

## End caps

Designation	Dimensions mm				
	d	D	H	L	E max.
<b>KASK04</b>	20	48	31	36	30
<b>KASK05</b>	25	54	33	38	30
<b>KASK06</b>	30	63	37	44	35
<b>KASK07</b>	35	73	39	47	39
<b>KASK08</b>	40	82	42	51	42
<b>KASK10</b>	50	92	47	56	46
<b>KASK12</b>	60	112	55	65	55

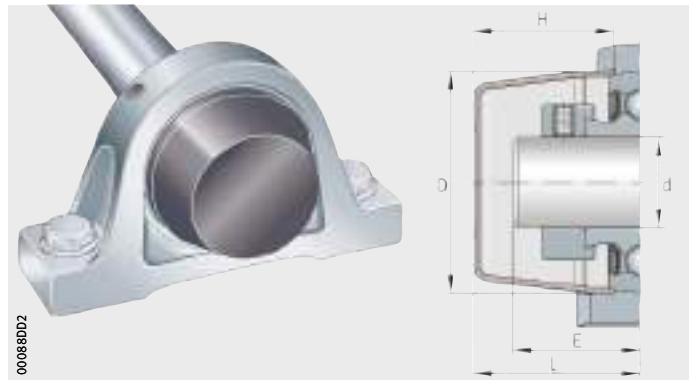

*Figure 2*  
Housing unit with bearing end cap

**Accuracy** The housings correspond predominantly to DIN 626-2 and ISO 3228, insofar as they are described therein.

**Dimensional tolerances** The dimensional tolerances for the machined surfaces of the flake graphite cast iron housings are  $\pm 0,25$  mm.  
The dimensional tolerances for the unmachined surfaces of flake graphite cast iron housings as well as machined to unmachined cast surfaces correspond to ISO 8062-3 (dimensional tolerance grade DCTG 9).  
The bearing seat of sheet steel housings is designed such that the bearing is seated in the housing with a defined swivel moment once the housing parts are bolted together.



# Plummer block housing units

Flake graphite cast iron housing  
With Corrotect coating

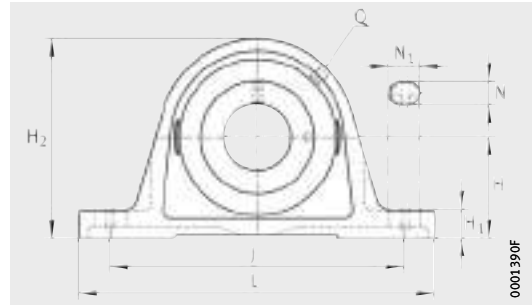

PASE...XL(-N)-FA125, RASE...XL(-N)-FA125



**Dimension table** - Dimensions in mm

Designation			Mass m ≈ kg	Dimensions					
Unit	Housing <sup>2)</sup>	Radial insert ball bearing		d	H	J	L	A	A <sub>1</sub>
<b>PASE20-XL-N-FA125</b>	ASE04	GRAE20-XL-NPP-B-FA125	0,58	<b>20</b>	33,3	97	130	32	19
<b>RASE20-XL-N-FA125</b>	ASE04	GE20-XL-KRR-B-FA125	0,61	<b>20</b>	33,3	97	130	32	19
<b>PASE25-XL-N-FA125</b>	ASE05	GRAE25-XL-NPP-B-FA125	0,72	<b>25</b>	36,5	103	130	36	21
<b>RASE25-XL-N-FA125</b>	ASE05	GE25-XL-KRR-B-FA125	0,75	<b>25</b>	36,5	103	130	36	21
<b>PASE30-XL-N-FA125</b>	ASE06	GRAE30-XL-NPP-B-FA125	1,11	<b>30</b>	42,9	118	158	40	25
<b>RASE30-XL-N-FA125</b>	ASE06	GE30-XL-KRR-B-FA125	1,18	<b>30</b>	42,9	118	158	40	25
<b>PASE35-XL-N-FA125</b>	ASE07	GRAE35-XL-NPP-B-FA125	1,6	<b>35</b>	47,6	126	163	45	27
<b>RASE35-XL-N-FA125</b>	ASE07	GE35-XL-KRR-B-FA125	1,69	<b>35</b>	47,6	126	163	45	27
<b>PASE40-XL-N-FA125</b>	ASE08	GRAE40-XL-NPP-B-FA125	1,84	<b>40</b>	49,2	138	179	48	30
<b>RASE40-XL-N-FA125</b>	ASE08	GE40-XL-KRR-B-FA125	1,95	<b>40</b>	49,2	138	179	48	30
<b>PASE45-XL-FA125</b>	ASE09	GRAE45-XL-NPP-B-FA125	2,12	<b>45</b>	54	150	192	48	32
<b>RASE45-XL-FA125</b>	ASE09	GE45-XL-KRR-B-FA125	2,21	<b>45</b>	54	150	192	48	32
<b>PASE50-XL-N-FA125</b>	ASE10	GRAE50-XL-NPP-B-FA125	2,55	<b>50</b>	57,2	158	200	54	34
<b>RASE50-XL-N-FA125</b>	ASE10	GE50-XL-KRR-B-FA125	2,7	<b>50</b>	57,2	158	200	54	34
<b>PASE60-XL-N-FA125</b>	ASE12	GRAE60-XL-NPP-B-FA125	4,35	<b>60</b>	69,9	190	240	60	42

<sup>1)</sup> To be ordered separately.  
For a description of the end caps, see page 386.

<sup>2)</sup> The housings have the Corrotect coating.

<sup>3)</sup> Lubrication nipple M6 fitted.

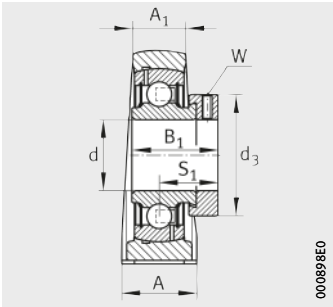

PASE...XL(N)-FA125

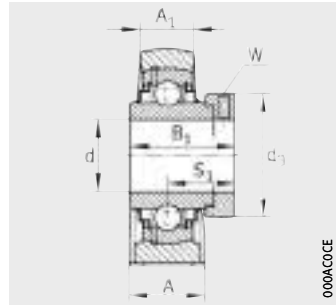

RASE...XL(N)-FA125

									Width across flats  W	Load carrying capacity Bearing			End cap <sup>1)</sup>
										Basic load ratings		Fatigue limit load  C <sub>ur</sub>  N	
H <sub>1</sub>	H <sub>2</sub>	N	N <sub>1</sub>	B <sub>1</sub>	S <sub>1</sub>	Q <sup>3)</sup>	d <sub>3</sub> max.	dyn. C <sub>r</sub> N		stat. C <sub>0r</sub> N			
14,5	64	11	19	31	23,5	Rp <sup>1/8</sup>	33	3	13 600	6 600	335	KASK04	
14,5	64	11	19	43,7	26,6	Rp <sup>1/8</sup>	33	3	13 600	6 600	335	KASK04	
14,5	70	11	19	31	23,5	Rp <sup>1/8</sup>	37,5	3	14 900	7 800	395	KASK05	
14,5	70	11	19	44,5	27	Rp <sup>1/8</sup>	37,5	3	14 900	7 800	395	KASK05	
17	82	14	22	35,8	26,8	Rp <sup>1/8</sup>	44	4	20 700	11 300	570	KASK06	
17	82	14	22	48,5	30,2	Rp <sup>1/8</sup>	44	4	20 700	11 300	570	KASK06	
19	93	14	21	39	29,5	Rp <sup>1/8</sup>	55	5	27 500	15 300	770	KASK07	
19	93	14	21	51,3	32,5	Rp <sup>1/8</sup>	55	5	27 500	15 300	770	KASK07	
19	99	14	26	43,8	32,8	M6	58	5	34 500	19 800	1 010	KASK08	
19	99	14	26	56,5	35,1	M6	58	5	34 500	19 800	1 010	KASK08	
21,5	107	14	29	43,8	32,8	M6	63	5	34 500	20 400	1 030	–	
21,5	107	14	29	56,5	35,1	M6	63	5	34 500	20 400	1 030	–	
21,5	115	18	23	43,8	32,8	Rp <sup>1/8</sup>	69	5	37 500	23 200	1 180	KASK10	
21,5	115	18	23	62,8	38,2	Rp <sup>1/8</sup>	69	5	37 500	23 200	1 180	KASK10	
25	140	18	28	53,1	39,6	Rp <sup>1/8</sup>	84	5	56 000	36 000	1 820	KASK12	



# Two-bolt flanged housing units

Flake graphite cast iron housing  
 Oval version  
 With Corrotect coating

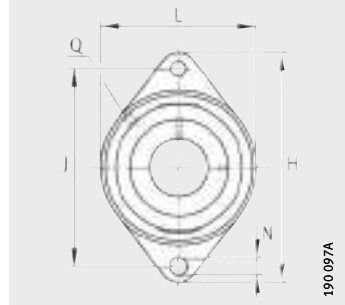

PCJT...-XL-N-FA125,  
 RCJT...-XL-N-FA125



**Dimension table** - Dimensions in mm

Designation			Mass	Dimensions				
Unit	Housing <sup>2)</sup>	Radial insert ball bearing		d	H	J	L	A
			m					
			≈ kg					
<b>PCJT20-XL-N-FA125</b>	CJT04	GRAE20-XL-NPP-B-FA125	0,45	<b>20</b>	112	90	61	28
<b>RCJT20-XL-N-FA125</b>	CJT04	GE20-XL-KRR-B-FA125	0,48	<b>20</b>	112	90	61	28
<b>PCJT25-XL-N-FA125</b>	CJT05	GRAE25-XL-NPP-B-FA125	0,58	<b>25</b>	124	99	70	26,5
<b>RCJT25-XL-N-FA125</b>	CJT05	GE25-XL-KRR-B-FA125	0,64	<b>25</b>	124	99	70	26,5
<b>PCJT30-XL-N-FA125</b>	CJT06	GRAE30-XL-NPP-B-FA125	0,84	<b>30</b>	142	116,5	80	29
<b>RCJT30-XL-N-FA125</b>	CJT06	GE30-XL-KRR-B-FA125	0,9	<b>30</b>	142	116,5	80	29
<b>PCJT35-XL-N-FA125</b>	CJT07	GRAE35-XL-NPP-B-FA125	1,18	<b>35</b>	155	130	92	30,5
<b>RCJT35-XL-N-FA125</b>	CJT07	GE35-XL-KRR-B-FA125	1,25	<b>35</b>	155	130	92	30,5
<b>PCJT40-XL-N-FA125</b>	CJT08	GRAE40-XL-NPP-B-FA125	1,57	<b>40</b>	172	143,5	105	34,5
<b>RCJT40-XL-N-FA125</b>	CJT08	GE40-XL-KRR-B-FA125	1,68	<b>40</b>	172	143,5	105	34,5
<b>PCJT50-XL-N-FA125</b>	CJT10	GRAE50-XL-NPP-B-FA125	1,98	<b>50</b>	190	157	116	39
<b>RCJT50-XL-N-FA125</b>	CJT10	GE50-XL-KRR-B-FA125	2,2	<b>50</b>	190	157	116	39
<b>PCJT60-XL-N-FA125</b>	CJT12	GRAE60-XL-NPP-B-FA125	3,37	<b>60</b>	238	202	138	46

- 1) To be ordered separately.  
 For a description of the end caps, see page 386.
- 2) The housings have the Corrotect coating.
- 3) Lubrication nipple M6 fitted.



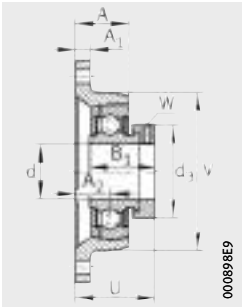

PCJT...XL-N-FA125

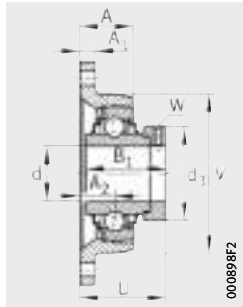

RCJT...XL-N-FA125

									Width across flats W	Load carrying capacity Bearing			End cap <sup>1)</sup>
										Basic load ratings		Fatigue limit load C <sub>ur</sub> N	
										dyn. C <sub>r</sub> N	stat. C <sub>0r</sub> N		
A <sub>1</sub>	A <sub>2</sub>	N	B <sub>1</sub>	U	V	Q <sup>3)</sup>	d <sub>3</sub> max.						
10	19	11,5	31	42,5	61	M6	33	3	13 600	6 600	335	KASK04	
10	19	11,5	43,7	45,6	61	M6	33	3	13 600	6 600	335	KASK04	
11	19	11,5	31	42,5	70	Rp <sup>1/8</sup>	37,5	3	14 900	7 800	395	KASK05	
11	19	11,5	44,5	46	70	Rp <sup>1/8</sup>	37,5	3	14 900	7 800	395	KASK05	
12	20	11,5	35,8	46,8	80	Rp <sup>1/8</sup>	44	4	20 700	11 300	570	KASK06	
12	20	11,5	48,5	50,2	80	Rp <sup>1/8</sup>	44	4	20 700	11 300	570	KASK06	
12,5	21	14	39	50,5	92	M6	55	5	27 500	15 300	770	KASK07	
12,5	21	14	51,3	53,5	92	M6	55	5	27 500	15 300	770	KASK07	
13	24	14	43,8	56,8	105	M6	58	5	34 500	19 800	1 010	KASK08	
13	24	14	56,5	59,1	105	M6	58	5	34 500	19 800	1 010	KASK08	
13	28	18	43,8	60,8	116	Rp <sup>1/8</sup>	69	5	37 500	23 200	1 180	KASK10	
13	28	18	62,8	66,2	116	Rp <sup>1/8</sup>	69	5	37 500	23 200	1 180	KASK10	
16	34	18	53,1	73,6	138	Rp <sup>1/8</sup>	84	5	56 000	36 000	1 820	KASK12	



# Three-bolt flanged housing units

Sheet steel housing  
 Round version  
 Corrosion-resistant VA design

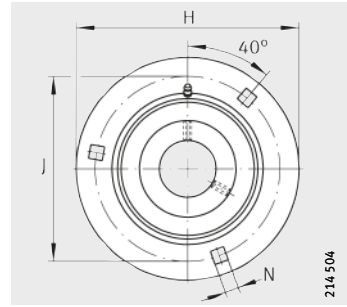

GRRY..-VA

**Dimension table** - Dimensions in mm

Designation			Mass m ≈ kg	Dimensions		
Unit	Housing	Radial insert ball bearing		d	H	J
<b>RRY12-VA</b> <sup>1)</sup>	2× FLAN40-MSB-VA	SUC201	0,21	<b>12</b>	81	63,5
<b>RRY15-VA</b> <sup>1)</sup>	2× FLAN40-MSB-VA	SUC202	0,2	<b>15</b>	81	63,5
<b>RRY17-VA</b> <sup>1)</sup>	2× FLAN40-MSB-VA	SUC203	0,19	<b>17</b>	81	63,5
<b>GRRY20-VA</b> <sup>2)</sup>	1× FLAN47-MSB-VA, 1× FLAN47-MSA-VA	SUC204	0,34	<b>20</b>	90,5	71,5
<b>RRY20-VA</b>	2× FLAN47-MSB-VA	SUC204	0,34	<b>20</b>	90,5	71,5
<b>GRRY25-VA</b> <sup>2)</sup>	1× FLAN52-MSB-VA, 1× FLAN52-MSA-VA	SUC205	0,38	<b>25</b>	95	76
<b>RRY25-VA</b>	2× FLAN52-MSB-VA	SUC205	0,38	<b>25</b>	95	76
<b>GRRY30-VA</b> <sup>2)</sup>	1× FLAN62-MSB-VA, 1× FLAN62-MSA-VA	SUC206	0,63	<b>30</b>	112,7	90,5
<b>RRY30-VA</b>	2× FLAN62-MSB-VA	SUC206	0,63	<b>30</b>	112,7	90,5

<sup>1)</sup> Housing and radial insert ball bearing must be ordered separately.

<sup>2)</sup> Bearing can be relubricated.

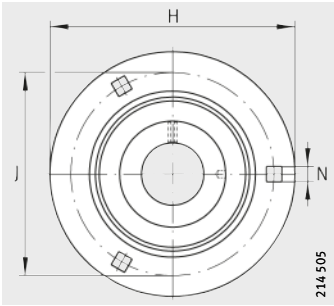

RRY..-VA

214 505

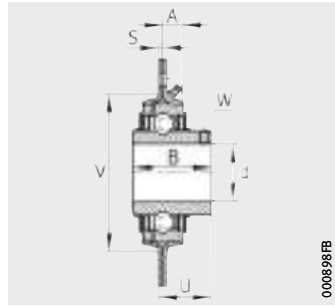

GRRY..-VA, RRY..-VA

000896B

						Number of screw mounting holes n	Width across flats W	Load carrying capacity			
								Bearing			Housing C <sub>0rG</sub> N
A	N	B	S	U	V	n	W	Basic load ratings		Fatigue limit load C <sub>ur</sub> N	
								dyn. C <sub>r</sub> N	stat. C <sub>0r</sub> N		
7	7,1	25	2	17,4	48	3	2,5	9 200	4 550	218	2 700
7	7,1	25	2	17,4	48	3	2,5	9 200	4 550	218	2 700
7	7,1	25	2	17,4	48	3	2,5	9 200	4 550	218	2 700
8	8,7	31	2	20,3	55	3	2,5	12 300	6 300	300	3 200
8	8,7	31	2	20,3	55	3	2,5	12 300	6 300	300	3 200
8,7	8,7	34,1	2	21,7	60	3	2,5	13 400	7 500	360	3 650
8,7	8,7	34,1	2	21,7	60	3	2,5	13 400	7 500	360	3 650
9	10,5	38,1	2,5	24,7	71	3	3	18 700	10 700	510	5 000
9	10,5	38,1	2,5	24,7	71	3	3	18 700	10 700	510	5 000



# Four-bolt flanged housing units

Flake graphite cast iron housing  
Square version  
With Corrotect coating

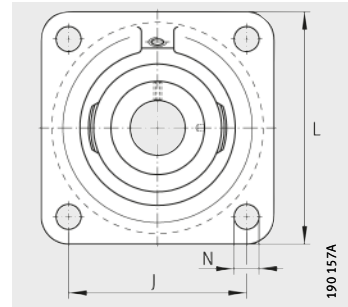

PCJ...XL(-N)-FA125,  
RCJ...XL(-N)-FA125

**Dimension table** - Dimensions in mm

Designation			Mass	Dimensions				
Unit	Housing <sup>2)</sup>	Radial insert ball bearing		m ≈ kg	d	J	L	A
<b>PCJ20-XL-N-FA125</b>	CJ04	GRAE20-XL-NPP-B-FA125	0,6	<b>20</b>	63,5	86	29	10
<b>RCJ20-XL-N-FA125</b>	CJ04	GE20-XL-KRR-B-FA125	0,65	<b>20</b>	63,5	86	29	10
<b>PCJ25-XL-N-FA125</b>	CJ05	GRAE25-XL-NPP-B-FA125	0,76	<b>25</b>	70	95	29	11
<b>RCJ25-XL-N-FA125</b>	CJ05	GE25-XL-KRR-B-FA125	0,82	<b>25</b>	70	95	29	11
<b>PCJ30-XL-N-FA125</b>	CJ06	GRAE30-XL-NPP-B-FA125	1,11	<b>30</b>	82,5	108	29	12
<b>RCJ30-XL-N-FA125</b>	CJ06	GE30-XL-KRR-B-FA125	1,17	<b>30</b>	82,5	108	29	12
<b>PCJ35-XL-N-FA125</b>	CJ07	GRAE35-XL-NPP-B-FA125	1,5	<b>35</b>	92	118	30,5	12,5
<b>RCJ35-XL-N-FA125</b>	CJ07	GE35-XL-KRR-B-FA125	1,58	<b>35</b>	92	118	30,5	12,5
<b>PCJ40-XL-N-FA125</b>	CJ08	GRAE40-XL-NPP-B-FA125	1,9	<b>40</b>	101,5	130	34,5	13
<b>RCJ40-XL-N-FA125</b>	CJ08	GE40-XL-KRR-B-FA125	2,02	<b>40</b>	101,5	130	34,5	13
<b>PCJ45-XL-FA125</b>	CJ09	GRAE45-XL-NPP-B-FA125	2,22	<b>45</b>	105	137	35	13
<b>RCJ45-XL-FA125</b>	CJ09	GE45-XL-KRR-B-FA125	2,26	<b>45</b>	105	137	35	13
<b>PCJ50-XL-N-FA125</b>	CJ10	GRAE50-XL-NPP-B-FA125	2,3	<b>50</b>	111	143	41	13
<b>RCJ50-XL-N-FA125</b>	CJ10	GE50-XL-KRR-B-FA125	2,53	<b>50</b>	111	143	41	13

<sup>1)</sup> To be ordered separately.  
For a description of the end caps, see page 386.

<sup>2)</sup> The housings have the Corrotect coating.

<sup>3)</sup> Lubrication nipple fitted.

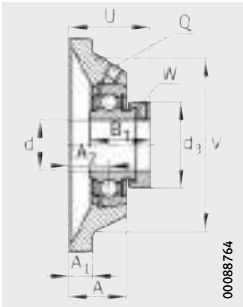

PCJ...XL(-N)-FA125

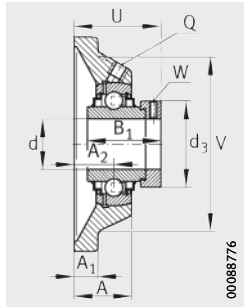

RCJ...XL(-N)-FA125

A <sub>2</sub>	N	B <sub>1</sub>	U	V	Q <sup>3)</sup>	d <sub>3</sub> max.	W	Load carrying capacity Bearing			End cap <sup>1)</sup>
								Basic load ratings		Fatigue limit load C <sub>ur</sub> N	
								dyn. C <sub>r</sub> N	stat. C <sub>0r</sub> N		
19	11,5	31	42,5	68	M6	33	3	13 600	6 600	335	KASK04
19	11,5	43,7	45,6	68	M6	33	3	13 600	6 600	335	KASK04
19	11,5	31	42,5	74	M6	37,5	3	14 900	7 800	395	KASK05
19	11,5	44,5	46	74	M6	37,5	3	14 900	7 800	395	KASK05
20	11,5	35,8	46,8	85	Rp <sup>1/8</sup>	44	4	20 700	11 300	570	KASK06
20	11,5	48,5	50,2	85	Rp <sup>1/8</sup>	44	4	20 700	11 300	570	KASK06
21	14	39	50,5	100	M6	55	5	27 500	15 300	770	KASK07
21	14	51,3	53,5	100	M6	55	5	27 500	15 300	770	KASK07
24	14	43,8	56,8	110	M6	58	5	34 500	19 800	1 010	KASK08
24	14	56,5	59,1	110	M6	58	5	34 500	19 800	1 010	KASK08
24	14	43,8	56,7	116	Rp <sup>1/8</sup>	63	5	34 500	20 400	1 030	–
24	14	56,5	59,1	116	Rp <sup>1/8</sup>	63	5	34 500	20 400	1 030	–
28	18	43,8	60,8	119	Rp <sup>1/8</sup>	69	5	37 500	23 200	1 180	KASK10
28	18	62,8	66,2	119	Rp <sup>1/8</sup>	69	5	37 500	23 200	1 180	KASK10





## High grade steel housing units, corrosion-resistant





Radial insert ball bearings  
in corrosion-resistant VA design or  
with Corrotect coating

# High grade steel housing units, corrosion-resistant

	Page
<b>Matrix</b>	Possible combinations of radial insert ball bearings and high grade steel housings..... 398
<b>Product overview</b>	High grade steel housing units, corrosion-resistant ..... 400
<b>Features</b>	Housings with integral radial insert ball bearing ..... 402 Lubrication ..... 402 Operating temperature ..... 402 Suffixes ..... 402
<b>Design and safety guidelines</b>	Compensation of static misalignments..... 403 Speed limits for radial insert ball bearings ..... 403 Load carrying capacity of housings ..... 404 Design of adjacent construction ..... 404
<b>Accuracy</b>	Dimensional tolerances ..... 405
<b>Dimension tables</b>	Plummer block housing units, high grade steel housings With long base, radial insert ball bearing in corrosion-resistant VA design, with grub screws in inner ring..... 406 With long base, radial insert ball bearing with Corrotect coating, with eccentric locking collar ..... 408 With short base, radial insert ball bearing in corrosion-resistant VA design, with grub screws in inner ring ..... 410 With short base, radial insert ball bearing with Corrotect coating, with eccentric locking collar ..... 412 Two-bolt flanged housing units, high grade steel housings Radial insert ball bearing in corrosion-resistant VA design, with grub screws in inner ring ..... 414 Radial insert ball bearing with Corrotect coating, with eccentric locking collar ..... 416 Four-bolt flanged housing units, high grade steel housings Radial insert ball bearing in corrosion-resistant VA design, with grub screws in inner ring ..... 418 Radial insert ball bearing with Corrotect coating, with eccentric locking collar ..... 420 Take-up housing units, sheet steel housings Radial insert ball bearing in corrosion-resistant VA design, with grub screws in inner ring ..... 422 Radial insert ball bearing with Corrotect coating, with eccentric locking collar ..... 424

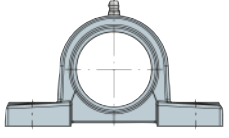



**Possible combinations  
Radial insert ball bearings and  
high grade steel housings**

<b>Radial insert ball bearing</b>	Housing	
	Plummer block housing	
		
Designation Shaft diameter d	<b>GEHSP</b>	
<b>SUC</b> 20 mm – 50 mm		<b>SUCSP</b> page 406
<b>GRAE..-XL-NPP-B-FA107/125</b> 20 mm – 50 mm		<b>CUGSP</b> page 408
<b>SUB</b> 20 mm – 50 mm		<b>SUBSP</b> Available by agreement
<b>SUG</b> 20 mm – 50 mm		<b>SUGSP</b> Available by agreement

Catalogue range, dimension table, see pages indicated.  
Other dimensions and combinations available by agreement.

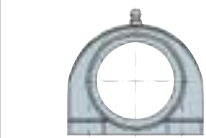

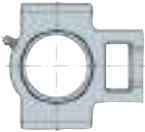
	Two-bolt flanged housing	Four-bolt flanged housing	Take-up housing
			
<b>GEHSPA</b>	<b>GEHSFL</b>	<b>GEHSF</b>	<b>GEHST</b>
<b>SUCSPA</b> page 410	<b>SUCSFL</b> page 414	<b>SUCSF</b> page 418	<b>SUCST</b> page 422
<b>CUGSPA</b> page 412	<b>CUGSFL</b> page 416	<b>CUGSF</b> page 420	<b>CUGST</b> page 424
<b>SUBSPA</b> Available by agreement	<b>SUBSFL</b> Available by agreement	<b>SUBSF</b> Available by agreement	<b>SUBST</b> Available by agreement
<b>SUGSPA</b> Available by agreement	<b>SUGSFL</b> Available by agreement	<b>SUGSF</b> Available by agreement	<b>SUGST</b> Available by agreement



## Product overview

## High grade steel housing units, corrosion-resistant

### Plummer block housing units

Radial insert ball bearing  
in corrosion-resistant VA design  
With grub screws and  
extended inner ring

SUCSP



SUCSPA



Radial insert ball bearing  
with Corrotect coating  
With eccentric locking collar

CUGSP



CUGSPA



### Flanged housing units

Radial insert ball bearing  
in corrosion-resistant VA design  
With grub screws and  
extended inner ring

SUCSFL



SUCSF



Radial insert ball bearing  
with Corrotect coating  
With eccentric locking collar

CUGSFL



CUGSF



## Take-up housing units

Radial insert ball bearings  
in corrosion-resistant VA design or  
with Corrotect coating

SUCST



CUGST



# High grade steel housing units, corrosion-resistant

## Features

Housing units with high grade steel housings are available as plummer block and flanged housing units as well as take-up housing units.

Plummer block housing units SUCSP and CUGSP have a long base. Plummer block housing units SUCSPA and CUGSPA have a short base.

Flanged housing units are available as two-bolt and four-bolt flanged housing units.

Take-up housing units have facilities for sliding motion. They are used where shafts must undergo substantial radial displacement travel.

The area of application of the housings correspond to that of the radial insert ball bearings fitted. They are suitable where humidity, contaminated water, salt spray mist, weakly alkaline or weakly acidic cleaning agents are present.

High grade steel housings do not have annular slots and cannot therefore be combined with end caps.

## Housings with integral radial insert ball bearing

The units are ready-to-fit and comprise high grade steel housings in which INA radial insert ball bearings are fitted.

The housings are single-piece components, have high load carrying capacity and are screw mounted to the adjacent construction by means of slots or threaded holes. For location, screws in accordance with DIN EN ISO 4762 are suitable. Less stringent tolerances are sufficient for the screw mounting surfaces.



In order to ensure function and reliability under all operating conditions, the bearings and housings are matched to each other with a defined swivel moment after mounting.

The swivel moment can be requested from Schaeffler.

## Radial insert ball bearings in corrosion-resistant VA design or with Corrotect coating

The units comprise high grade steel housings and radial insert ball bearings with a spherical outer ring in a corrosion-resistant VA design or with Corrotect coating.

Location on the shaft in the case of housing units SUCS and SUBS is by means of grub screws and in the case of housing units SUGS by means of an eccentric locking collar. Housing units CUGS with the radial insert ball bearing GRAE...-FA125 have an eccentric locking collar.

## Lubrication

For relubrication of radial insert ball bearings, the housing bore has a lubrication groove and the housing has a lubrication hole suitable for conventional lubrication nipples with a precision thread  $1/4'' - 28$  UNF in accordance with ANSI B1.1. The lubrication nipple is already fitted at the time of delivery.

## Operating temperature

Units with a high grade steel housing are suitable for operating temperatures from  $-35$  °C to  $+100$  °C.

## Suffixes

Suffixes for available designs, see table.

## Available designs

Suffix	Design	Design
FA125	Bearing with Corrotect coating, corrosion-resistant	Standard

## Design and safety guidelines

The chapter Technical principles brings together the essential guidelines on the design of bearing arrangements, lubrication, mounting and dismantling and the operation of bearings, see page 32.

## Compensation of static misalignments

Bearings with a spherical outer ring, fitted in housings with a concave bore, can compensate for static misalignment of the shaft, *Figure 1*.

For units with a lubrication groove in the housing and lubrication hole in the radial insert ball bearing, the following applies:

- Up to  $\pm 2,5^\circ$ , the units can be relubricated.
- Between  $\pm 2,5^\circ$  and  $\pm 5^\circ$ , the possibility of relubrication is dependent on the specific unit. Please contact us in this case.
- Over  $\pm 5^\circ$ , relubrication is no longer possible.



The units must not be used to support swivelling or tumbling motion.



*Figure 1*  
Compensation  
of static shaft misalignment

## Speed limits for radial insert ball bearings

The speed limits are dependent on the load, the clearance between the bearing bore and shaft and the friction of the seals, see page 363.



# High grade steel housing units, corrosion-resistant

## Load carrying capacity of housings

Due to their versatile characteristics, INA housing units can be easily used in almost all industrial sectors.



If bearing arrangements are planned for equipment in which a malfunction could be hazardous to persons or an unplanned stoppage of the machine could cause major disruption, it is essential that you consult us before proceeding with the design.

## Radial load carrying capacity

High grade steel housings can support the same radial loads as the radial insert ball bearings fitted.

The static load carrying capacity  $C_{0r}$  of the radial insert ball bearings is stated in the dimension tables.



Where shock loads are present, appropriate safety factors must be applied. In this case, please contact us.

## Axial load carrying capacity

The axial load carrying capacity of radial insert ball bearings must not exceed the axial load carrying capacity of the housing.

The axial load carrying capacity of high grade steel housings is  $0,5 \cdot C_{0r}$ .

## Design of adjacent construction

The permissible shaft tolerance is dependent on the speed, load and the radial insert ball bearing fitted. Shafts of the tolerance classes h6 @ to h9 @ can be used. Conventional drawn shafts will suffice for most applications.

## Screw mounting surfaces

Recommendations for the screw mounting surfaces are as follows:

- roughness of the screw mounting surface max. Ra 12,5 (Rzmax 63)
- geometrical and positional tolerance 0,04/100 concave, spherical not permissible.
- In the event of high loads occurring parallel to the mounting surface of plummer block housing units (in the case of high grade steel housings with long base), the use of additional dowel pins to DIN EN ISO 8752 is recommended. In this case, through holes (see centre punch mark for housing ASE) must be applied, see *Figure 1*, page 129.

## Fixing screws

The screw connection should be designed in accordance with VDI 2230; friction coefficient  $\mu = 0,12$  (90%).

Screws of grade 8.8 or better can be used for fixing.

The maximum tightening torques applicable to this screw grade must not be exceeded even if screws of a higher grade are used.

In principle, we recommend that the screw connection should only be tightened to 70% of the values stated in the standard.

For fixing, hexagonal socket head screws in accordance with DIN EN ISO 4762 or hexagonal socket head screws with a coarse pitch full thread in accordance with DIN EN ISO 4017 should be used. The screws should be combined as a minimum with a washer in accordance with DIN EN ISO 7089 or DIN EN ISO 7090.

Screws and accessories for location are not included in the delivery.

All screws and other accessories used for location should be in the corrosion-resistant VA design.

**Accuracy** The dimensions of high grade steel housings conform to JIS B 1559.

**Dimensional tolerances** The dimensional tolerances for the machined surfaces of the high grade steel housings are  $\pm 0,25$  mm.  
The dimensional tolerances for unmachined as well as machined to unmachined surfaces correspond to JIS B 0403 (dimensional tolerance grade CT 10).



# Plummer block housing units

- High grade steel housing
- With long base
- Radial insert ball bearing in corrosion-resistant VA design
- With grub screws in inner ring

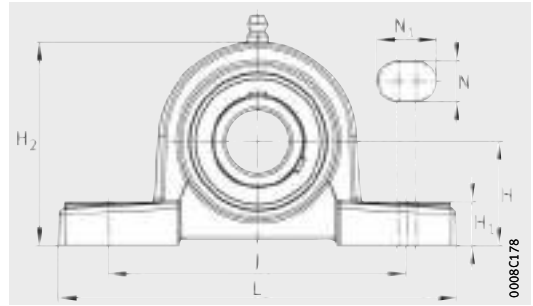

SUCSP

**Dimension table** - Dimensions in mm

Designation			Mass m ≈ kg	Dimensions					
Unit	Housing	Radial insert ball bearing		d	H	J	L	A	H <sub>1</sub>
<b>SUCSP204</b>	GEHSP204	SUC204	0,9	<b>20</b>	33,3	95	127	38	14
<b>SUCSP205</b>	GEHSP205	SUC205	0,95	<b>25</b>	36,5	105	140	38	15
<b>SUCSP206</b>	GEHSP206	SUC206	1,6	<b>30</b>	42,9	121	165	48	17
<b>SUCSP207</b>	GEHSP207	SUC207	1,9	<b>35</b>	47,6	127	167	48	18
<b>SUCSP208</b>	GEHSP208	SUC208	2,4	<b>40</b>	49,2	137	184	54	18
<b>SUCSP209</b>	GEHSP209	SUC209	2,7	<b>45</b>	54	146	190	54	20
<b>SUCSP210</b>	GEHSP210	SUC210	3,1	<b>50</b>	57,2	159	206	60	21



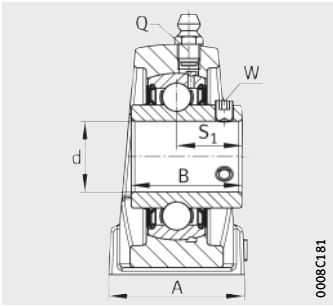

SUCSP

H <sub>2</sub>	N	N <sub>1</sub>	B	S <sub>1</sub>	Q	Width across flats W	Load carrying capacity Bearing		
							Basic load ratings		Fatigue limit load C <sub>ur</sub> N
							dyn. C <sub>r</sub> N	stat. C <sub>0r</sub> N	
65	13	19	31	18,3	1/4" - 28 UNF	2,5	12 300	6 300	300
71	13	19	34,1	19,8	1/4" - 28 UNF	2,5	13 400	7 500	360
83	17	21	38,1	22,2	1/4" - 28 UNF	3	18 700	10 700	510
93	17	21	42,9	25,4	1/4" - 28 UNF	3	24 600	14 600	700
98	17	21	49,2	30,2	1/4" - 28 UNF	4	31 500	18 900	910
106	17	21	49,2	30,2	1/4" - 28 UNF	4	31 500	19 400	930
114	20	25	51,6	32,6	1/4" - 28 UNF	5	33 500	22 100	1 060



# Plummer block housing units

- High grade steel housing
- With long base
- Radial insert ball bearing with Corrotect coating
- With eccentric locking collar

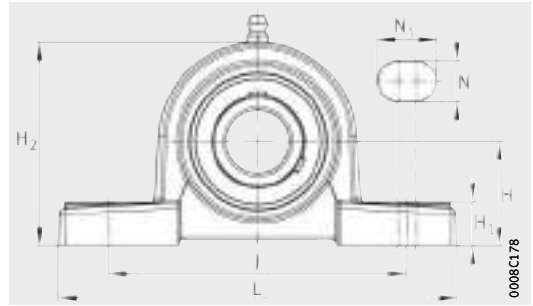

CUGSP

**Dimension table** - Dimensions in mm

Designation			Mass m ≈ kg	Dimensions					
Unit	Housing	Radial insert ball bearing		d	H	J	L	A	H <sub>1</sub>
<b>CUGSP204</b>	GEHSP204	GRAE20-XL-NPP-B-FA107/125	0,9	<b>20</b>	33,3	95	127	38	14
<b>CUGSP205</b>	GEHSP205	GRAE25-XL-NPP-B-FA107/125	0,94	<b>25</b>	36,5	105	140	38	15
<b>CUGSP206</b>	GEHSP206	GRAE30-XL-NPP-B-FA107/125	1,61	<b>30</b>	42,9	121	165	48	17
<b>CUGSP207</b>	GEHSP207	GRAE35-XL-NPP-B-FA107/125	1,95	<b>35</b>	47,6	127	167	48	18
<b>CUGSP208</b>	GEHSP208	GRAE40-XL-NPP-B-FA107/125	2,4	<b>40</b>	49,2	137	184	54	18
<b>CUGSP209</b>	GEHSP209	GRAE45-XL-NPP-B-FA107/125	2,72	<b>45</b>	54	146	190	54	20
<b>CUGSP210</b>	GEHSP210	GRAE50-XL-NPP-B-FA107/125	3,05	<b>50</b>	57,2	159	206	60	21

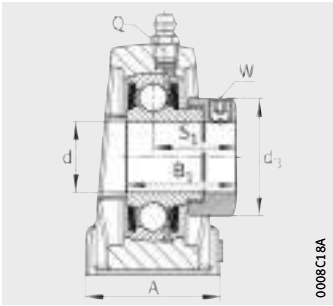

0008C18A

CUGSP

							Width across flats  W	Load carrying capacity Bearing		
								Basic load ratings		Fatigue limit load  C <sub>ur</sub>  N
H <sub>2</sub>	N	N <sub>1</sub>	B <sub>1</sub>	S <sub>1</sub>	Q	d <sub>3</sub>  max.		dyn. C <sub>r</sub>  N	stat. C <sub>0r</sub>  N	
65	13	19	31	23,5	1/4" - 28 UNF	33	3	13 600	6 600	335
71	13	19	31	23,5	1/4" - 28 UNF	37,5	3	14 900	7 800	395
83	17	21	35,8	26,8	1/4" - 28 UNF	44	4	20 700	11 300	570
93	17	21	39	29,5	1/4" - 28 UNF	55	5	27 500	15 300	770
98	17	21	43,8	32,8	1/4" - 28 UNF	58	5	34 500	19 800	1 010
106	17	21	43,8	32,8	1/4" - 28 UNF	63	5	34 500	20 400	1 030
114	20	25	43,8	32,8	1/4" - 28 UNF	69	5	37 500	23 200	1 180



# Plummer block housing units

- High grade steel housing
- With short base
- Radial insert ball bearing in corrosion-resistant VA design
- With grub screws in inner ring

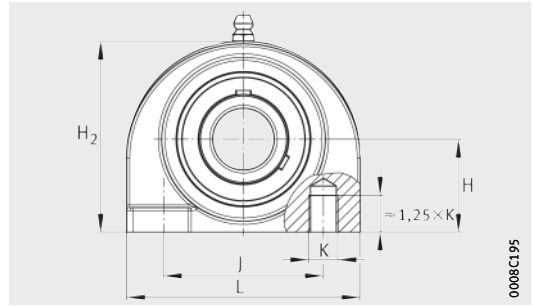

SUCSPA

**Dimension table** - Dimensions in mm

Designation			Mass m ≈ kg	Dimensions				
Unit	Housing	Radial insert ball bearing		d	H	J	L	A
<b>SUCSPA204</b>	GEHSPA204	SUC204	0,68	<b>20</b>	30,2	52	76	38
<b>SUCSPA205</b>	GEHSPA205	SUC205	0,85	<b>25</b>	36,5	56	84	38
<b>SUCSPA206</b>	GEHSPA206	SUC206	1,1	<b>30</b>	42,9	66	94	48
<b>SUCSPA207</b>	GEHSPA207	SUC207	1,4	<b>35</b>	47,6	80	110	48
<b>SUCSPA208</b>	GEHSPA208	SUC208	1,8	<b>40</b>	49,2	84	116	54
<b>SUCSPA209</b>	GEHSPA209	SUC209	2,5	<b>45</b>	54,2	90	120	54
<b>SUCSPA210</b>	GEHSPA210	SUC210	3,1	<b>50</b>	57,2	94	130	60

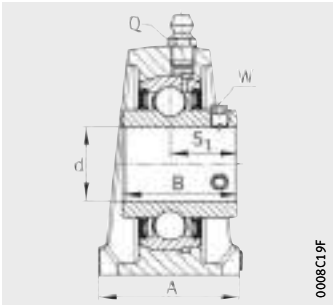

0008C19F

SUCSPA

					Width across flats W	Load carrying capacity Bearing		
						Basic load ratings		Fatigue limit load C <sub>ur</sub> N
H <sub>2</sub>	B	S <sub>1</sub>	K	Q		dyn. C <sub>r</sub> N	stat. C <sub>0r</sub> N	
62	31	18,3	M10	1/4" – 28 UNF	2,5	12 300	6 300	300
72	34,1	19,8	M10	1/4" – 28 UNF	2,5	13 400	7 500	360
84	38,1	22,2	M14	1/4" – 28 UNF	3	18 700	10 700	510
95	42,9	25,4	M14	1/4" – 28 UNF	3	24 600	14 600	700
100	49,2	30,2	M14	1/4" – 28 UNF	4	31 500	18 900	910
108	49,2	30,2	M14	1/4" – 28 UNF	4	31 500	19 400	930
116	51,6	32,6	M16	1/4" – 28 UNF	5	33 500	22 100	1 060



# Plummer block housing units

- High grade steel housing
- With short base
- Radial insert ball bearing with Corrotect coating
- With eccentric locking collar

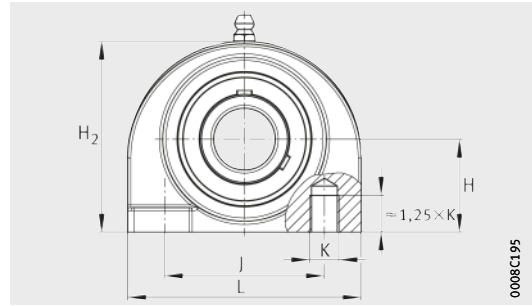

CUGSPA

**Dimension table** - Dimensions in mm

Designation			Mass m ≈ kg	Dimensions				
Unit	Housing	Radial insert ball bearing		d	H	J	L	A
<b>CUGSPA204</b>	GEHSPA204	GRAE20-XL-NPP-B-FA107/125	0,68	<b>20</b>	30,2	52	76	38
<b>CUGSPA205</b>	GEHSPA205	GRAE25-XL-NPP-B-FA107/125	0,84	<b>25</b>	36,5	56	84	38
<b>CUGSPA206</b>	GEHSPA206	GRAE30-XL-NPP-B-FA107/125	1,11	<b>30</b>	42,9	66	94	48
<b>CUGSPA207</b>	GEHSPA207	GRAE35-XL-NPP-B-FA107/125	1,45	<b>35</b>	47,6	80	110	48
<b>CUGSPA208</b>	GEHSPA208	GRAE40-XL-NPP-B-FA107/125	1,8	<b>40</b>	49,2	84	116	54
<b>CUGSPA209</b>	GEHSPA209	GRAE45-XL-NPP-B-FA107/125	2,52	<b>45</b>	54,2	90	120	54
<b>CUGSPA210</b>	GEHSPA210	GRAE50-XL-NPP-B-FA107/125	3,05	<b>50</b>	57,2	94	130	60

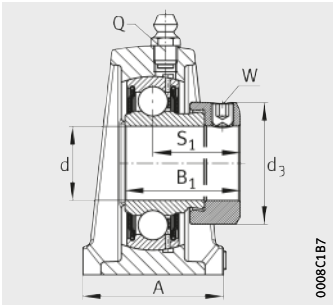

0008C1B7

CUGSPA

						Width across flats W	Load carrying capacity Bearing		
							Basic load ratings		Fatigue limit load
H <sub>2</sub>	B <sub>1</sub>	S <sub>1</sub>	K	Q	d <sub>3</sub> max.		dyn. C <sub>r</sub> N	stat. C <sub>0r</sub> N	C <sub>ur</sub> N
62	31	23,5	M10	1/4" - 28 UNF	33	3	13 600	6 600	335
72	31	23,5	M10	1/4" - 28 UNF	37,5	3	14 900	7 800	395
84	35,8	26,8	M14	1/4" - 28 UNF	44	4	20 700	11 300	570
95	39	29,5	M14	1/4" - 28 UNF	55	5	27 500	15 300	770
100	43,8	32,8	M14	1/4" - 28 UNF	58	5	34 500	19 800	1 010
108	43,8	32,8	M14	1/4" - 28 UNF	63	5	34 500	20 400	1 030
116	43,8	32,8	M16	1/4" - 28 UNF	69	5	37 500	23 200	1 180



## Two-bolt flanged housing units

High grade steel housing

Radial insert ball bearing in corrosion-resistant VA design

With grub screws in inner ring

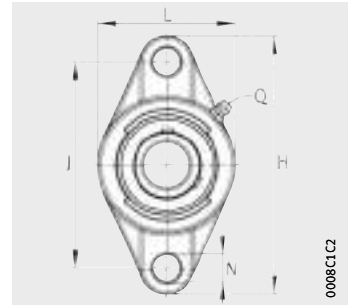

SUCSFL

**Dimension table** - Dimensions in mm

Designation			Mass m ≈ kg	Dimensions					
Unit	Housing	Radial insert ball bearing		d	H	J	L	A	A <sub>1</sub>
<b>SUCSFL204</b>	GEHSFL204	SUC204	0,5	<b>20</b>	113	90	60	25,5	12
<b>SUCSFL205</b>	GEHSFL205	SUC205	0,65	<b>25</b>	130	99	68	27	15
<b>SUCSFL206</b>	GEHSFL206	SUC206	0,9	<b>30</b>	148	117	80	31	14
<b>SUCSFL207</b>	GEHSFL207	SUC207	1,2	<b>35</b>	161	130	90	34	16
<b>SUCSFL208</b>	GEHSFL208	SUC208	1,6	<b>40</b>	175	144	100	36	16
<b>SUCSFL209</b>	GEHSFL209	SUC209	1,8	<b>45</b>	188	148	108	38	18
<b>SUCSFL210</b>	GEHSFL210	SUC210	2,1	<b>50</b>	197	157	115	40	18



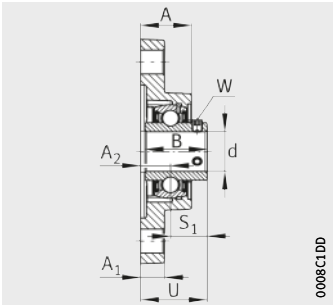

SUCSFL

0008C1DD

						Width across flats W	Load carrying capacity Bearing		
							Basic load ratings		Fatigue limit load
A <sub>2</sub>	N	B	S <sub>1</sub>	U	Q		dyn. C <sub>r</sub> N	stat. C <sub>0r</sub> N	C <sub>ur</sub> N
15	12	31	18,3	33,3	1/4" - 28 UNF	2,5	12 300	6 300	300
16	16	34,1	19,8	35,8	1/4" - 28 UNF	2,5	13 400	7 500	360
18	16	38,1	22,2	40,2	1/4" - 28 UNF	3	18 700	10 700	510
19	16	42,9	25,4	44,4	1/4" - 28 UNF	3	24 600	14 600	700
21	16	49,2	30,2	51,2	1/4" - 28 UNF	4	31 500	18 900	910
22	19	49,2	30,2	52,2	1/4" - 28 UNF	4	31 500	19 400	930
22	19	51,6	32,6	54,6	1/4" - 28 UNF	5	33 500	22 100	1 060



# Two-bolt flanged housing units

High grade steel housing  
 Radial insert ball bearing with Corrotect coating  
 With eccentric locking collar

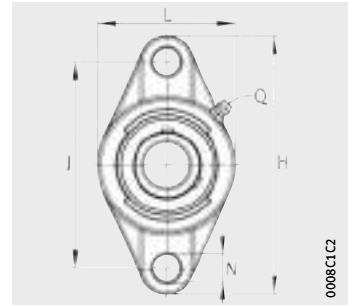

CUGSFL

**Dimension table** - Dimensions in mm

Designation			Mass m ≈ kg	Dimensions					
Unit	Housing	Radial insert ball bearing		d	H	J	L	A	A <sub>1</sub>
<b>CUGSFL204</b>	GEHSFL204	GRAE20-XL-NPP-B-FA107/125	0,5	<b>20</b>	113	90	60	25,5	12
<b>CUGSFL205</b>	GEHSFL205	GRAE25-XL-NPP-B-FA107/125	0,64	<b>25</b>	130	99	68	27	15
<b>CUGSFL206</b>	GEHSFL206	GRAE30-XL-NPP-B-FA107/125	0,91	<b>30</b>	148	117	80	31	14
<b>CUGSFL207</b>	GEHSFL207	GRAE35-XL-NPP-B-FA107/125	1,25	<b>35</b>	161	130	90	34	16
<b>CUGSFL208</b>	GEHSFL208	GRAE40-XL-NPP-B-FA107/125	1,6	<b>40</b>	175	144	100	36	16
<b>CUGSFL209</b>	GEHSFL209	GRAE45-XL-NPP-B-FA107/125	1,82	<b>45</b>	188	148	108	38	18
<b>CUGSFL210</b>	GEHSFL210	GRAE50-XL-NPP-B-FA107/125	2,05	<b>50</b>	197	157	115	40	18

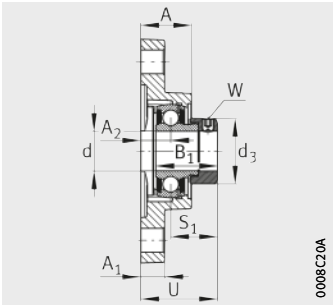

CUGSFL

							Width across flats W	Load carrying capacity Bearing		
								Basic load ratings		Fatigue limit load
A <sub>2</sub>	N	B <sub>1</sub>	S <sub>1</sub>	U	Q	d <sub>3</sub> max.	dyn. C <sub>r</sub> N	stat. C <sub>0r</sub> N	C <sub>ur</sub> N	
15	12	31	23,5	38,5	1/4" – 28 UNF	33	3	13 600	6 600	335
16	16	31	23,5	39,5	1/4" – 28 UNF	37,5	3	14 900	7 800	395
18	16	35,8	26,8	44,8	1/4" – 28 UNF	44	4	20 700	11 300	570
19	16	39	29,5	48,5	1/4" – 28 UNF	55	5	27 500	15 300	770
21	16	43,8	32,8	53,8	1/4" – 28 UNF	58	5	34 500	19 800	1 010
22	19	43,8	32,8	54,8	1/4" – 28 UNF	63	5	34 500	20 400	1 030
22	19	43,8	32,8	54,8	1/4" – 28 UNF	69	5	37 500	23 200	1 180



# Four-bolt flanged housing units

High grade steel housing

Radial insert ball bearing in corrosion-resistant VA design

With grub screws in inner ring

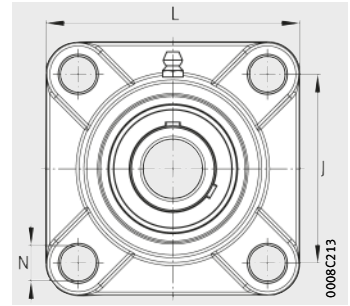

SUCSF

**Dimension table** - Dimensions in mm

Designation			Mass m ≈ kg	Dimensions					
Unit	Housing	Radial insert ball bearing		d	J	L	A	A <sub>1</sub>	A <sub>2</sub>
<b>SUCSF204</b>	GEHSF204	SUC204	0,63	<b>20</b>	64	86	25,5	12	15
<b>SUCSF205</b>	GEHSF205	SUC205	0,85	<b>25</b>	70	95	27	14	16
<b>SUCSF206</b>	GEHSF206	SUC206	1,17	<b>30</b>	83	108	31	14	18
<b>SUCSF207</b>	GEHSF207	SUC207	1,51	<b>35</b>	92	117	34	16	19
<b>SUCSF208</b>	GEHSF208	SUC208	2	<b>40</b>	102	130	36	16	21
<b>SUCSF209</b>	GEHSF209	SUC209	2,2	<b>45</b>	105	137	38	18	22
<b>SUCSF210</b>	GEHSF210	SUC210	2,4	<b>50</b>	111	143	40	18	22

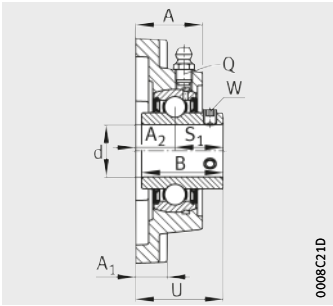

SUCSF

					Width across flats W	Load carrying capacity Bearing		
						Basic load ratings		Fatigue limit load C <sub>ur</sub> N
N	B	S <sub>1</sub>	U	Q		dyn. C <sub>r</sub> N	stat. C <sub>0r</sub> N	
12	31	18,3	33,3	1/4" - 28 UNF	2,5	12 300	6 300	300
12	34,1	19,8	35,8	1/4" - 28 UNF	2,5	13 400	7 500	360
12	38,1	22,2	40,2	1/4" - 28 UNF	3	18 700	10 700	510
14	42,9	25,4	44,4	1/4" - 28 UNF	3	24 600	14 600	700
16	49,2	30,2	51,2	1/4" - 28 UNF	4	31 500	18 900	910
16	49,2	30,2	52,2	1/4" - 28 UNF	4	31 500	19 400	930
16	51,6	32,6	54,6	1/4" - 28 UNF	5	33 500	22 100	1 060



# Four-bolt flanged housing units

High grade steel housing  
 Radial insert ball bearing with Corrotect coating  
 With eccentric locking collar

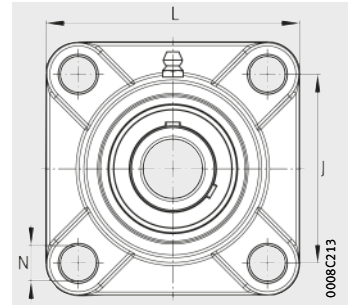

CUGSF

**Dimension table** - Dimensions in mm

Designation			Mass m ≈ kg	Dimensions				
Unit	Housing	Radial insert ball bearing		d	J	L	A	A <sub>1</sub>
<b>CUGSF204</b>	GEHSF204	GRAE20-XL-NPP-B-FA107/125	0,63	<b>20</b>	64	86	25,5	12
<b>CUGSF205</b>	GEHSF205	GRAE25-XL-NPP-B-FA107/125	0,84	<b>25</b>	70	95	27	14
<b>CUGSF206</b>	GEHSF206	GRAE30-XL-NPP-B-FA107/125	1,18	<b>30</b>	83	108	31	14
<b>CUGSF207</b>	GEHSF207	GRAE35-XL-NPP-B-FA107/125	1,56	<b>35</b>	92	117	34	16
<b>CUGSF208</b>	GEHSF208	GRAE40-XL-NPP-B-FA107/125	2	<b>40</b>	102	130	36	16
<b>CUGSF209</b>	GEHSF209	GRAE45-XL-NPP-B-FA107/125	2,22	<b>45</b>	105	137	38	18
<b>CUGSF210</b>	GEHSF210	GRAE50-XL-NPP-B-FA107/125	2,35	<b>50</b>	111	143	40	18

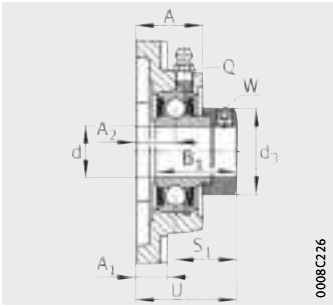

0008C236

CUGSF

A <sub>2</sub>	N	B <sub>1</sub>	S <sub>1</sub>	U	Q	d <sub>3</sub> max.	Width across flats W	Load carrying capacity Bearing		
								Basic load ratings		Fatigue limit load C <sub>ur</sub> N
								dyn. C <sub>r</sub> N	stat. C <sub>0r</sub> N	
15	12	31	23,5	38,5	1/4" - 28 UNF	33	3	13 600	6 600	335
16	12	31	23,5	39,5	1/4" - 28 UNF	37,5	3	14 900	7 800	395
18	12	35,8	26,8	44,8	1/4" - 28 UNF	44	4	20 700	11 300	570
19	14	39	29,5	48,5	1/4" - 28 UNF	55	5	27 500	15 300	770
21	16	43,8	32,8	53,8	1/4" - 28 UNF	58	5	34 500	19 800	1 010
22	16	43,8	32,8	54,8	1/4" - 28 UNF	63	5	34 500	20 400	1 030
22	16	43,8	32,8	54,8	1/4" - 28 UNF	69	5	37 500	23 200	1 180



# Take-up housing units

High grade steel housing  
 Radial insert ball bearing in corrosion-resistant VA design  
 With grub screws in inner ring

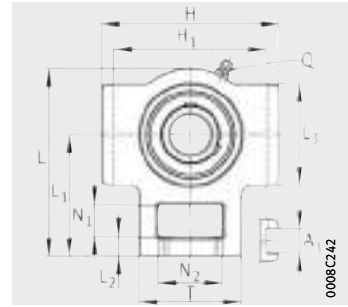

SUCST

**Dimension table** - Dimensions in mm

Designation			Mass m ≈ kg	Dimensions							
Unit	Housing	Radial insert ball bearing		d	H	H <sub>1</sub>	L	L <sub>1</sub>	L <sub>2</sub>	L <sub>3</sub>	N
<b>SUCST204</b>	GEHST204	SUC204	0,9	<b>20</b>	89	76	94	61	10	51	19
<b>SUCST205</b>	GEHST205	SUC205	1	<b>25</b>	89	76	97	62	10	51	19
<b>SUCST206</b>	GEHST206	SUC206	1,4	<b>30</b>	102	89	113	70	10	57	22
<b>SUCST207</b>	GEHST207	SUC207	1,8	<b>35</b>	102	89	129	78	13	64	22
<b>SUCST208</b>	GEHST208	SUC208	2,7	<b>40</b>	114	102	144	88	16	83	29
<b>SUCST209</b>	GEHST209	SUC209	2,9	<b>45</b>	117	102	144	87	16	83	29
<b>SUCST210</b>	GEHST210	SUC210	3	<b>50</b>	117	102	149	90	16	86	29



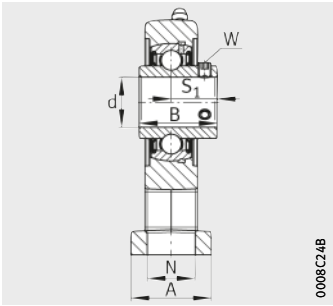

SUCST

N <sub>1</sub>	N <sub>2</sub>	A	A <sub>1</sub>	B	S <sub>1</sub>	T	Q	Width across flats W	Load carrying capacity Bearing		
									Basic load ratings		Fatigue limit load C <sub>ur</sub> N
									dyn. C <sub>r</sub> N	stat. C <sub>0r</sub> N	
16	32	32	12	31	18,3	51	1/4" - 28 UNF	2,5	12 300	6 300	300
16	32	32	12	34,1	19,8	51	1/4" - 28 UNF	2,5	13 400	7 500	360
16	37	37	12	38,1	22,2	56	1/4" - 28 UNF	3	18 700	10 700	510
16	37	37	12	42,9	25,4	64	1/4" - 28 UNF	3	24 600	14 600	700
19	49	49	16	49,2	30,2	83	1/4" - 28 UNF	4	31 500	18 900	910
19	49	49	16	49,2	30,2	83	1/4" - 28 UNF	4	31 500	19 400	930
19	49	49	16	51,6	32,6	83	1/4" - 28 UNF	5	33 500	22 100	1 060



# Take-up housing units

High grade steel housing  
 Radial insert ball bearing with Corrotect coating  
 With eccentric locking collar

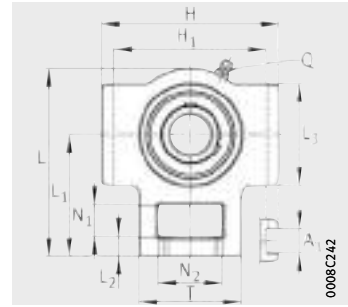

CUGST

**Dimension table** - Dimensions in mm

Designation			Mass m ≈ kg	Dimensions							
Unit	Housing	Radial insert ball bearing		d	H	H <sub>1</sub>	L	L <sub>1</sub>	L <sub>2</sub>	L <sub>3</sub>	N
<b>CUGST204</b>	GEHST204	GRAE20-XL-NPP-B-FA107/125	0,9	<b>20</b>	89	76	94	61	10	51	19
<b>CUGST205</b>	GEHST205	GRAE25-XL-NPP-B-FA107/125	0,99	<b>25</b>	89	76	97	62	10	51	19
<b>CUGST206</b>	GEHST206	GRAE30-XL-NPP-B-FA107/125	1,41	<b>30</b>	102	89	113	70	10	57	22
<b>CUGST207</b>	GEHST207	GRAE35-XL-NPP-B-FA107/125	1,85	<b>35</b>	102	89	129	78	13	64	22
<b>CUGST208</b>	GEHST208	GRAE40-XL-NPP-B-FA107/125	2,7	<b>40</b>	114	102	144	88	16	83	29
<b>CUGST209</b>	GEHST209	GRAE45-XL-NPP-B-FA107/125	2,92	<b>45</b>	117	102	144	87	16	83	29
<b>CUGST210</b>	GEHST210	GRAE50-XL-NPP-B-FA107/125	2,95	<b>50</b>	117	102	149	90	16	86	29

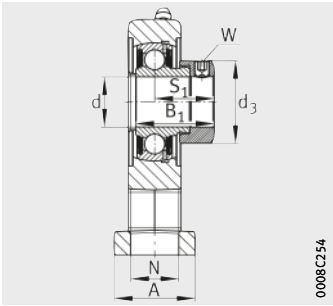

CUGST

									Width across flats W	Load carrying capacity Bearing		
										Basic load ratings		Fatigue limit load
N <sub>1</sub>	N <sub>2</sub>	A	A <sub>1</sub>	B <sub>1</sub>	S <sub>1</sub>	T	Q	d <sub>3</sub> max.	d <sub>3</sub>	dyn. C <sub>r</sub> N	stat. C <sub>0r</sub> N	C <sub>ur</sub> N
16	32	32	12	31	23,5	51	1/4" – 28 UNF	33	3	13 600	6 600	335
16	32	32	12	31	23,5	51	1/4" – 28 UNF	37,5	3	14 900	7 800	395
16	37	37	12	35,8	26,8	56	1/4" – 28 UNF	44	4	20 700	11 300	570
16	37	37	12	39	29,5	64	1/4" – 28 UNF	55	5	27 500	15 300	770
19	49	49	16	43,8	32,8	83	1/4" – 28 UNF	58	5	34 500	19 800	1 010
19	49	49	16	43,8	32,8	83	1/4" – 28 UNF	63	5	34 500	20 400	1 030
19	49	49	16	43,8	32,8	83	1/4" – 28 UNF	69	5	37 500	23 200	1 180





## Plastic housing units, corrosion-resistant





Radial insert ball bearings  
in corrosion-resistant VA design or  
with Corrotect coating

# Plastic housing units, corrosion-resistant

	Page
<b>Matrix</b>	Possible combinations of radial insert ball bearings and plastic housings..... 428
<b>Product overview</b>	Plastic housing units, corrosion-resistant..... 430
<b>Features</b>	Housings with integral radial insert ball bearing..... 432 Radial insert ball bearings in corrosion-resistant VA design or with Corrotect coating ..... 433 Operating temperature ..... 433 Suffixes ..... 433
<b>Design and safety guidelines</b>	Compensation of static misalignments..... 433 Speed limits for radial insert ball bearings ..... 433 Radial load carrying capacity ..... 434 Axial load carrying capacity..... 434 Design of adjacent construction..... 434 Bearing end caps..... 435 Back Seal component ..... 436
<b>Accuracy</b>	Tolerances of plastic housings ..... 437 Shaft tolerances for radial insert ball bearings ..... 437
<b>Dimension tables</b>	Plummer block housing units, with long or short base Radial insert ball bearings in corrosion-resistant VA design, with grub screws or eccentric locking collar ..... 438 Radial insert ball bearings with Corrotect coating, with eccentric locking collar ..... 440 Two-bolt flanged housing units, narrow or wide version Radial insert ball bearings in corrosion-resistant VA design, with grub screws or eccentric locking collar ..... 446 Radial insert ball bearings with Corrotect coating, with eccentric locking collar ..... 448 Four-bolt flanged housing units Radial insert ball bearings in corrosion-resistant VA design, with grub screws or eccentric locking collar ..... 454 Radial insert ball bearings with Corrotect coating, with eccentric locking collar ..... 456 Take-up housing units, guide slots or guide surfaces on both sides, hole for threaded rod Radial insert ball bearings in corrosion-resistant VA design, with grub screws or eccentric locking collar ..... 458 Radial insert ball bearings with Corrotect coating, with eccentric locking collar ..... 460

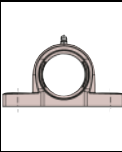

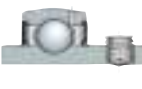

**Possible combinations  
Radial insert ball bearings and  
plastic housings**

Radial insert ball bearing		Housing	
		Plummer block housing	
			
Designation Shaft diameter d		GEHPP	GEHPPA
<b>SUB</b> 20 mm – 50 mm		<b>SUBPP</b> page 438	<b>SUBPPA</b> page 442
<b>SUC</b> 20 mm – 50 mm		<b>SUCPP</b> page 438	<b>SUCPPA</b> page 442
<b>SUG</b> 20 mm – 50 mm		<b>SUGPP</b> page 438	<b>SUGPPA</b> page 442
<b>GRAE..-XL-NPP-B-FA107/125</b> 20 mm – 50 mm		<b>CUGPP</b> page 440	<b>CUGPPA</b> page 444

Catalogue range, dimension table, see pages indicated.  
Other dimensions and combinations available by agreement.

 Combinations not possible or not advisable.

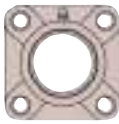
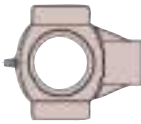
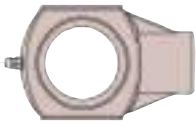
Two-bolt flanged housing		Four-bolt flanged housing	Take-up housing	
				
<b>GEHPFL</b>	<b>GEHPCTL</b>	<b>GEHPF</b>	<b>GEHPT</b>	<b>GEHPHE</b>
<b>SUBPFL</b> page 446	<b>SUBPCTL</b> page 450	<b>SUBPF</b> page 454	<b>SUBPT</b> page 458	<b>SUBPHE</b> page 462
<b>SUCPFL</b> page 446		<b>SUCPF</b> page 454	<b>SUCPT</b> page 458	<b>SUCPHE</b> page 462
<b>SUGPFL</b> page 446	<b>SUGPCTL</b> page 450	<b>SUGPF</b> page 454	<b>SUGPT</b> page 458	<b>SUGPHE</b> page 462
<b>CUGPFL</b> page 448	<b>CUGPCTL</b> page 452	<b>CUGPF</b> page 456	<b>CUGPT</b> page 460	<b>CUGPHE</b> page 464



# Product overview Plastic housing units, corrosion-resistant

## Plummer block housing units

SUBPP, SUCPP,  
SUGPP, CUGPP



SUBPPA, SUCPPA,  
SUGPPA, CUGPPA



## Flanged housing units

SUBPFL, SUCPFL,  
SUGPFL, CUGPFL



SUBPCTL, SUGPCTL,  
CUGPCTL



SUBPF, SUCPF  
SUGPF, CUGPF



## Take-up housing units

SUBPT, SUCPT,  
SUGPT, CUGPT



SUBPHE, SUCPHE,  
SUGPHE, CUGPHE





**Accessories**

Back Seal component



End caps  
Open or closed design



# Plastic housing units, corrosion-resistant

## Features

Housing units with plastic housings made from PBT are available as plummer block and flanged housing units as well as take-up housing units.

The glass fibre reinforced material PBT is highly resistant to humidity, UV radiation, bacterial and fungal attacks as well as many chemical agents.

## Housings with integral radial insert ball bearing

The units are ready-to-fit and comprise plastic housings in which INA radial insert ball bearings are fitted.

Location on the shaft in the case of housing units SUC and SUB is by means of grub screws and in the case of housing units SUG by means of an eccentric locking collar. Housing units with radial insert ball bearing GRAE and the suffix FA125 have an eccentric locking collar.

The units are used predominantly as locating bearings, but are also suitable as non-locating bearings under low loads and speeds.

The housings are screw mounted on the adjacent construction. Less stringent tolerances are sufficient for the screw mounting surfaces.



In order to ensure function and reliability under all operating conditions, the bearings and housings are matched to each other with a defined swivel moment after mounting.

The swivel moment can be requested from Schaeffler.

## Plummer block housing units

Plummer block housing units are available with a long base or short base. The housings are made from glass fibre reinforced plastic PBT, are not split and are screw mounted to the adjacent construction by means of slots or threaded holes. Fixing screws to DIN EN ISO 4762 are suitable.

For relubrication of radial insert ball bearings, the housing bore has a lubrication groove and the housing has a lubrication hole suitable for conventional lubrication nipples with a precision thread  $1/4'' - 28$  UNF in accordance with ANSI B1.1. The lubrication nipple is supplied already fitted, a bearing end cap is supplied loose at the time of delivery.

## Flanged housing units

Flanged housing units are available as two-bolt and four-bolt flanged housing units. For location, the housings have through holes for screws to DIN EN ISO 4762.

The housing material, the design of lubrication arrangements and the delivered condition correspond to those of plummer block housing units.

## Take-up housing units

Take-up housing units have facilities for sliding motion. They are used where shafts must undergo substantial radial displacement travel.

The housing material, the design of lubrication arrangements and the delivered condition correspond to those of plummer block housing units.

**Radial insert ball bearings in corrosion-resistant VA design or with Corrotect coating**

The housing units are available with radial insert ball bearings in the corrosion-resistant VA design or with Corrotect coating, suffix FA125.

**Operating temperature**

Housing units with or without a Back Seal component are suitable for operating temperatures from -20 °C to +100 °C. If bearing end caps are used, the maximum temperature is reduced to +80 °C.

**Suffixes**

Suffixes for available designs, see table.

**Available designs**

Suffix	Design	Design
FA107	Units CUG have radial insert ball bearings with lubrication holes on the locating side	Standard
FA125	Units CUG have radial insert ball bearings with Corrotect coating, corrosion-resistant	

**Design and safety guidelines**

The chapter Technical principles brings together the essential guidelines on the design of bearing arrangements, lubrication, mounting and dismantling and the operation of bearings, see page 32.

Due to their versatile characteristics, INA housing units can be easily used in almost all industrial sectors.



It is always and fundamentally the responsibility of the designer of a machine to ensure that a malfunction of housing units cannot be hazardous to persons. An unplanned stoppage of the machine should not cause major disruptions in operation. In both cases, it is therefore essential that you contact us before design work is carried out.

**Compensation of static misalignments**

Due to the spherical outer ring of the bearing and the concave housing bore, housing units can compensate for static misalignments of the shaft, see page 363.

**Speed limits for radial insert ball bearings**

The speed limits are dependent on the load, the clearance between the bearing bore and shaft and the friction of the seals, see page 363.



# Plastic housing units, corrosion-resistant

## Radial load carrying capacity

Plastic housings are suitable for moderate loads. The radial static load carrying capacity  $C_{0rG}$  of plastic housings and the static load carrying capacity  $C_{0r}$  of the radial insert ball bearings is stated in the relevant dimension tables.

## Axial load carrying capacity

The axial operating load of the unit must not exceed the axial load carrying capacity of the housing.

The axial load carrying capacity of plastic housings is  $C_{0aG} = 0,25 \cdot C_{0rG}$ .

## Design of adjacent construction

The permissible shaft tolerance is dependent on the speed, load and the radial insert ball bearing fitted. Shafts of the tolerance classes h6 © to h9 © can be used. Conventional drawn shafts will suffice for most applications.

## Screw mounting surfaces

Recommendations for the screw mounting surfaces are as follows:

- roughness of the screw mounting surface max. Ra 12,5 (Rzmax 63)
- geometrical and positional tolerance 0,04/100 concave, spherical not permissible.
- For high loads occurring parallel to the mounting surface of plummer block housing units (in the case of plastic housings with long base), please contact Schaeffler.

## Fixing screws

The screw connection should be designed in accordance with VDI 2230; friction coefficient  $\mu = 0,12$  (90%).

Screws of grade 8.8 or better can be used for fixing.

The maximum tightening torques applicable to this screw grade must not be exceeded even if screws of a higher grade are used.

In principle, we recommend that the screw connection should only be tightened to 70% of the values stated in the standard.

For fixing, hexagonal socket head screws in accordance with DIN EN ISO 4762 or hexagonal socket head screws with a coarse pitch full thread in accordance with DIN EN ISO 4017 should be used. The screws should be combined as a minimum with a washer in accordance with DIN EN ISO 7089 or DIN EN ISO 7090.

Screws and accessories for location are not included in the delivery.

All screws and other accessories used for location should be in the corrosion-resistant VA design.

## Bearing end caps

Each housing unit is supplied with a closed end cap CC. For all units, open end caps CO with an integral rotary shaft seal are available by agreement, *Figure 1* and table.

- ① Open end cap with integral rotary shaft seal
- ② Closed end cap

*Figure 1*  
Open or closed end caps

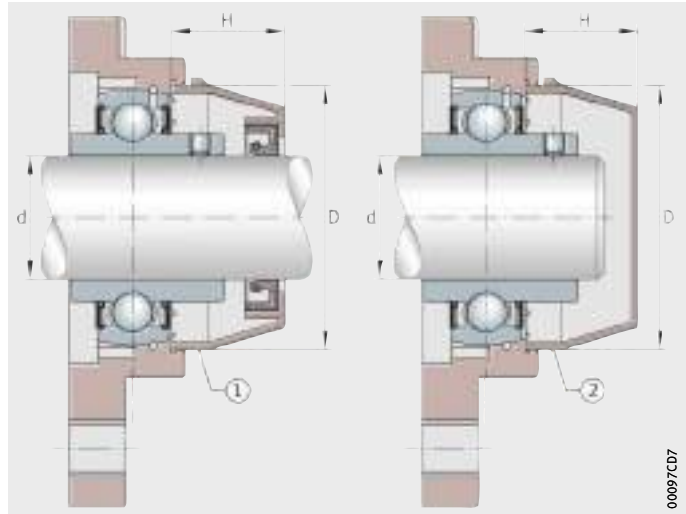

### Bearing end caps for plastic housing units

Designation		Dimensions mm		
Closed end cap	Open end cap	d	D	H
CC204	CO204	20	50,1	23
CC205	CO205	25	55	25
CC206	CO206	30	64	30
CC207	CO207	35	74,6	32
CC208	CO208	40	84	37
CC209	CO209	45	89,2	41
CC210	CO210	50	94,2	47



# Plastic housing units, corrosion-resistant

## Back Seal component

For flanged housing units SUBPFL, SUGPFL, CUGPFL, SUBPF, SUGPF and CUGPF, a Back Seal component BS from NBR is available with a spring washer made from corrosion-resistant steel, material number 1.4301, that closes off the rear face of the housing, *Figure 2*, *Figure 3* and table.

CUGPF  
CUGPFL

① Back Seal component

*Figure 2*  
Flanged housing units  
with Back Seal component



*Figure 3*  
Dimensions  
of Back Seal component

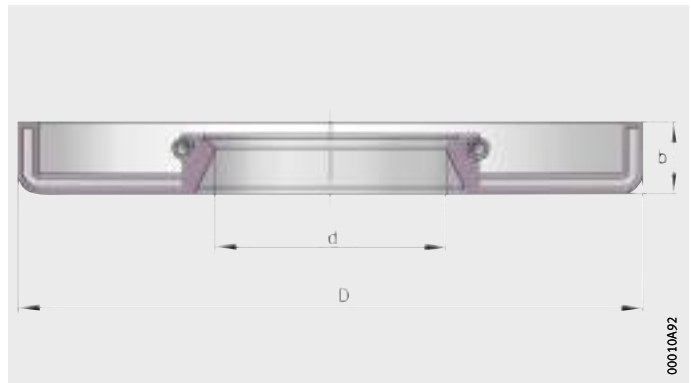

## Designations and dimensions of Back Seal components

Designation	Dimensions mm		
	d	b	D
BS204	20	6	52
BS205	25	6	62
BS206	30	6	72
BS207	35	6	82
BS208	40	6	88
BS209	45	6	93
BS210	50	6	98

**Accuracy  
Tolerances  
of plastic housings**

The dimensional, geometrical and positional tolerances of plastic housings correspond to DIN 16742.

**Shaft tolerances  
for insert bearings**

Shafts of the tolerance classes h6  $\oplus$  to h9  $\oplus$  can be used.  
Conventional drawn shafts will suffice for most applications.



# Plummer block housing units

Plastic housing  
 With long base  
 Radial insert ball bearing  
 in corrosion-resistant VA design  
 With grub screw or eccentric locking collar

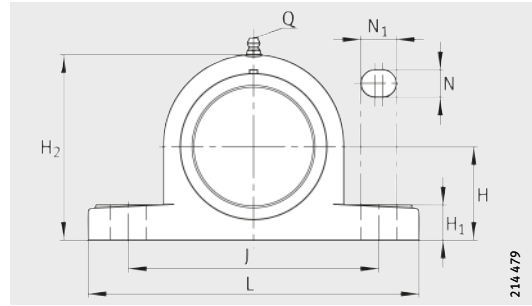

SUBPP, SUCPP, SUGPP

**Dimension table** - Dimensions in mm

Designation			Mass m ≈ kg	Dimensions								
Unit <sup>1)</sup>	Housing	Radial insert ball bearing		d	H	J	L	A	H <sub>1</sub>	H <sub>2</sub>	N	N <sub>1</sub>
<b>SUBPP204</b>	GEHPP204	SUB204	0,28	<b>20</b>	33,3	95	127	38	14,2	65,5	11	14
<b>SUCPP204</b>	GEHPP204	SUC204	0,3	<b>20</b>	33,3	95	127	38	14,2	65,5	11	14
<b>SUBPP205</b>	GEHPP205	SUB205	0,33	<b>25</b>	36,5	105	140	38	14,5	71	11	14
<b>SUCPP205</b>	GEHPP205	SUC205	0,36	<b>25</b>	36,5	105	140	38	14,5	71	11	14
<b>SUBPP206</b>	GEHPP206	SUB206	0,5	<b>30</b>	42,9	119	162	46	17,8	83	14	18
<b>SUCPP206</b>	GEHPP206	SUC206	0,55	<b>30</b>	42,9	119	162	46	17,8	83	14	18
<b>SUBPP207</b>	GEHPP207	SUB207	0,7	<b>35</b>	47,6	127	167	48	18	94	14	18
<b>SUCPP207</b>	GEHPP207	SUC207	0,77	<b>35</b>	47,6	127	167	48	18	94	14	18
<b>SUBPP208</b>	GEHPP208	SUB208	0,89	<b>40</b>	49,2	137	184	54	19,5	98	14	18
<b>SUCPP208</b>	GEHPP208	SUC208	0,98	<b>40</b>	49,2	137	184	54	19,5	98	14	18
<b>SUBPP209</b>	GEHPP209	SUB209	1,02	<b>45</b>	54	146	192	54	23	106	17	20
<b>SUCPP209<sup>2)</sup></b>	GEHPP209	SUC209	1,08	<b>45</b>	54	146	192	54	23	106	17	20
<b>SUBPP210</b>	GEHPP210	SUB210	1,21	<b>50</b>	57,2	159	206	60	23	114	17	20
<b>SUCPP210<sup>2)</sup></b>	GEHPP210	SUC210	1,32	<b>50</b>	57,2	159	206	60	23	114	17	20

**Dimension table** - Dimensions in mm

Designation			Mass m ≈ kg	Dimensions								
Unit <sup>1)</sup>	Housing	Radial insert ball bearing		d	H	J	L	A	H <sub>1</sub>	H <sub>2</sub>	N	N <sub>1</sub>
<b>SUGPP204</b>	GEHPP204	SUG204	0,31	<b>20</b>	33,3	95	127	38	14,2	65,5	11	14
<b>SUGPP205</b>	GEHPP205	SUG205	0,37	<b>25</b>	36,5	105	140	38	14,5	71	11	14
<b>SUGPP206</b>	GEHPP206	SUG206	0,56	<b>30</b>	42,9	119	162	46	17,8	83	14	18
<b>SUGPP207</b>	GEHPP207	SUG207	0,81	<b>35</b>	47,6	127	167	48	18	94	14	18
<b>SUGPP208</b>	GEHPP208	SUG208	0,97	<b>40</b>	49,2	137	184	54	19,5	98	14	18
<b>SUGPP209</b>	GEHPP209	SUG209	1,12	<b>45</b>	54	146	192	54	23	106	17	20
<b>SUGPP210<sup>2)</sup></b>	GEHPP210	SUG210	1,31	<b>50</b>	57,2	159	206	60	23	114	17	20

<sup>1)</sup> Available end caps, see page 435.

<sup>2)</sup> Available by agreement.



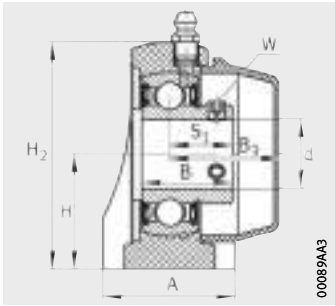

SUBPP

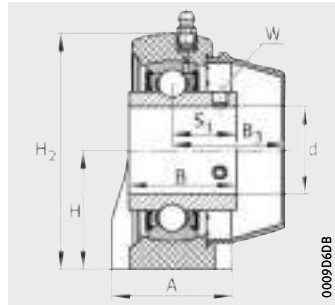

SUCPP

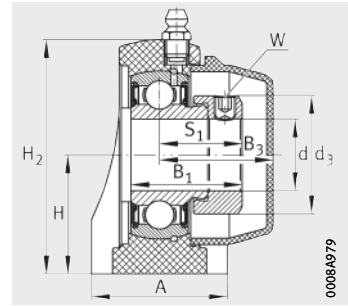

SUGPP

				Width across flats  W	Load carrying capacity			
					Bearing			Housing  C <sub>0rG</sub>  N
					Basic load ratings		Fatigue limit load  C <sub>ur</sub>  N	
B	B <sub>3</sub>	S <sub>1</sub>	Q	dyn. C <sub>r</sub> N	stat. C <sub>0r</sub> N			
26	31,65	18	1/4" - 28 UNF	2,5	12 300	6 300	300	7 700
31	31,65	18,3	1/4" - 28 UNF	2,5	12 300	6 300	300	7 700
28	34,05	19,5	1/4" - 28 UNF	2,5	13 400	7 500	360	10 000
34,1	34,05	19,8	1/4" - 28 UNF	2,5	13 400	7 500	360	10 000
30,5	39,95	21	1/4" - 28 UNF	3	18 700	10 700	510	10 600
38,1	39,95	22,2	1/4" - 28 UNF	3	18 700	10 700	510	10 600
35,45	44,85	25,45	1/4" - 28 UNF	3	24 600	14 600	700	10 800
42,9	44,85	25,4	1/4" - 28 UNF	3	24 600	14 600	700	10 800
39,45	51,5	28,95	1/4" - 28 UNF	4	31 500	18 900	910	11 100
49,2	51,5	30,2	1/4" - 28 UNF	4	31 500	18 900	910	11 100
41,5	53,7	30,5	1/4" - 28 UNF	4	31 500	19 400	930	11 400
49,2	53,7	30,2	1/4" - 28 UNF	4	31 500	19 400	930	11 400
43,5	60,9	32	1/4" - 28 UNF	5	33 500	22 100	1 060	11 700
51,6	60,9	32,6	1/4" - 28 UNF	5	33 500	22 100	1 060	11 700

					Width across flats  W	Load carrying capacity			
						Bearing			Housing  C <sub>0rG</sub>  N
						Basic load ratings		Fatigue limit load  C <sub>ur</sub>  N	
B <sub>1</sub>	B <sub>3</sub>	S <sub>1</sub>	Q	d <sub>3</sub> max.	dyn. C <sub>r</sub> N	stat. C <sub>0r</sub> N			
31,5	31,65	23,5	1/4" - 28 UNF	33	3	12 300	6 300	300	7 700
32	34,05	23,5	1/4" - 28 UNF	37,5	3	13 400	7 500	360	10 000
36,3	39,95	26,8	1/4" - 28 UNF	44	4	18 700	10 700	510	10 600
39,5	44,85	29,5	1/4" - 28 UNF	55	5	24 600	14 600	700	10 800
43,8	51,5	32,8	1/4" - 28 UNF	58	5	31 500	18 900	910	11 100
43,8	53,7	32,8	1/4" - 28 UNF	63	5	31 500	19 400	930	11 400
44,3	60,9	32,8	1/4" - 28 UNF	69	5	33 500	22 100	1 060	11 700



# Plummer block housing units

- Plastic housing
- With long base
- Radial insert ball bearing with Corrotect coating
- With eccentric locking collar

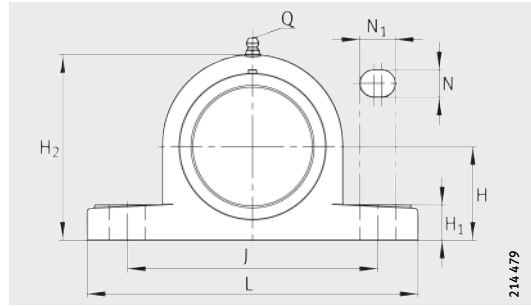

CUGPP

**Dimension table** - Dimensions in mm

Designation			Mass m ≈ kg	Dimensions						
Unit <sup>1)</sup>	Housing	Radial insert ball bearing		d	H	J	L	A	H <sub>1</sub>	H <sub>2</sub>
<b>CUGPP204</b>	GEHPP204	GRAE20-XL-NPP-B-FA107/125	0,32	<b>20</b>	33,3	95	127	38	14,2	65,5
<b>CUGPP205</b>	GEHPP205	GRAE25-XL-NPP-B-FA107/125	0,37	<b>25</b>	36,5	105	140	38	14,5	71
<b>CUGPP206</b>	GEHPP206	GRAE30-XL-NPP-B-FA107/125	0,61	<b>30</b>	42,9	119	162	46	17,8	83
<b>CUGPP207</b>	GEHPP207	GRAE35-XL-NPP-B-FA107/125	0,87	<b>35</b>	47,6	127	167	48	18	94
<b>CUGPP208</b>	GEHPP208	GRAE40-XL-NPP-B-FA107/125	1,06	<b>40</b>	49,2	137	184	54	19,5	98
<b>CUGPP209<sup>2)</sup></b>	GEHPP209	GRAE45-XL-NPP-B-FA107/125	1,19	<b>45</b>	54	146	192	54	23	106
<b>CUGPP210<sup>2)</sup></b>	GEHPP210	GRAE50-XL-NPP-B-FA107/125	1,37	<b>50</b>	57,2	159	206	60	23	114

<sup>1)</sup> Available end caps, see page 435.

<sup>2)</sup> Available by agreement.

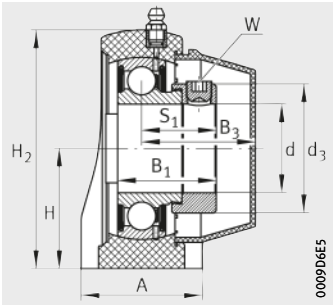

CUGPP

							Width across flats  W	Load carrying capacity			
								Bearing			Housing  $C_{0rG}$ N
								Basic load ratings		Fatigue limit load	
N	$N_1$	$B_1$	$B_3$	$S_1$	Q	$d_3$ max.		dyn. $C_r$ N	stat. $C_{0r}$ N	$C_{ur}$ N	
11	14	31	31,65	23,5	$1/4'' - 28 \text{ UNF}$	33	3	13 600	6 600	335	7 700
11	14	31	34,05	23,5	$1/4'' - 28 \text{ UNF}$	37,5	3	14 900	7 800	395	10 000
14	18	35,8	39,95	26,8	$1/4'' - 28 \text{ UNF}$	44	4	20 700	11 300	570	10 600
14	18	39	44,85	29,5	$1/4'' - 28 \text{ UNF}$	55	5	27 500	15 300	770	10 800
14	18	43,8	51,5	32,8	$1/4'' - 28 \text{ UNF}$	58	5	34 500	19 800	1 010	11 100
17	20	43,8	53,7	32,8	$1/4'' - 28 \text{ UNF}$	63	5	34 500	20 400	1 030	11 400
17	20	43,8	60,9	32,8	$1/4'' - 28 \text{ UNF}$	69	5	37 500	23 200	1 180	11 700



# Plummer block housing units

Plastic housing  
 With short base  
 Radial insert ball bearing  
 in corrosion-resistant VA design  
 With grub screw or eccentric locking collar

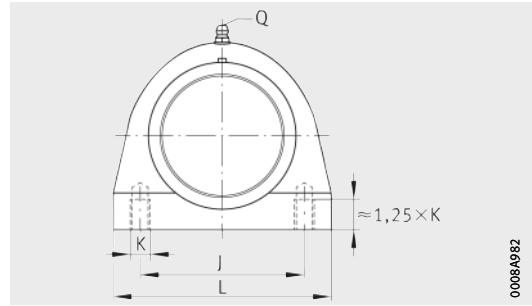

SUBPPA, SUCPPA, SUGPPA

**Dimension table** - Dimensions in mm

Designation			Mass m ≈ kg	Dimensions					
Unit <sup>1)</sup>	Housing	Radial insert ball bearing		d	H	J	L	A	H <sub>2</sub>
<b>SUBPPA204</b>	GEHPPA204	SUB204	0,26	<b>20</b>	33,3	50,8	72,8	34,5	66
<b>SUCPPA204</b>	GEHPPA204	SUC204	0,28	<b>20</b>	33,3	50,8	72,8	34,5	66
<b>SUBPPA205</b>	GEHPPA205	SUB205	0,31	<b>25</b>	36,5	50,8	76,2	39,5	73,5
<b>SUCPPA205</b>	GEHPPA205	SUC205	0,34	<b>25</b>	36,5	50,8	76,2	39,5	73,5
<b>SUBPPA206</b>	GEHPPA206	SUB206	0,47	<b>30</b>	42,9	76,2	101	42,5	84
<b>SUCPPA206</b>	GEHPPA206	SUC206	0,52	<b>30</b>	42,9	76,2	101	42,5	84
<b>SUBPPA207</b>	GEHPPA207	SUB207	0,7	<b>35</b>	47,6	82,6	110	47,5	95
<b>SUCPPA207</b>	GEHPPA207	SUC207	0,76	<b>35</b>	47,6	82,6	110	47,5	95
<b>SUBPPA208</b>	GEHPPA208	SUB208	0,83	<b>40</b>	49,2	88,9	120	48	100,5
<b>SUCPPA208</b>	GEHPPA208	SUC208	0,92	<b>40</b>	49,2	88,9	120	48	100,5
<b>SUBPPA209<sup>2)</sup></b>	GEHPPA209	SUB209	0,97	<b>45</b>	54	95,3	124	50	108,5
<b>SUCPPA209<sup>2)</sup></b>	GEHPPA209	SUC209	1,03	<b>45</b>	54	95,3	124	50	108,5
<b>SUBPPA210<sup>2)</sup></b>	GEHPPA210	SUB210	1,15	<b>50</b>	57,2	101,6	135	54	115
<b>SUCPPA210<sup>2)</sup></b>	GEHPPA210	SUC210	1,26	<b>50</b>	57,2	101,6	135	54	115

**Dimension table** - Dimensions in mm

Designation			Mass m ≈ kg	Dimensions					
Unit <sup>1)</sup>	Housing	Radial insert ball bearing		d	H	J	L	A	H <sub>2</sub>
<b>SUGPPA204</b>	GEHPPA204	SUG204	0,29	<b>20</b>	33,3	50,8	72,8	34,5	66
<b>SUGPPA205</b>	GEHPPA205	SUG205	0,35	<b>25</b>	36,5	50,8	76,2	39,5	73,5
<b>SUGPPA206</b>	GEHPPA206	SUG206	0,52	<b>30</b>	42,9	76,2	101	42,5	84
<b>SUGPPA207</b>	GEHPPA207	SUG207	0,8	<b>35</b>	47,6	82,6	110	47,5	95
<b>SUGPPA208</b>	GEHPPA208	SUG208	0,91	<b>40</b>	49,2	88,9	120	48	100,5
<b>SUGPPA209<sup>2)</sup></b>	GEHPPA209	SUG209	1,07	<b>45</b>	54	95,3	124	50	108,5
<b>SUGPPA210<sup>2)</sup></b>	GEHPPA210	SUG210	1,25	<b>50</b>	57,2	101,6	135	54	115

<sup>1)</sup> Available end caps, see page 435.

<sup>2)</sup> Available by agreement.

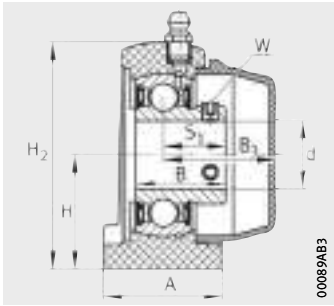

SUBPPA

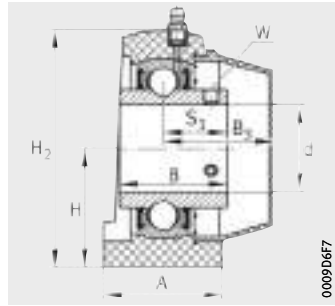

SUCPPA

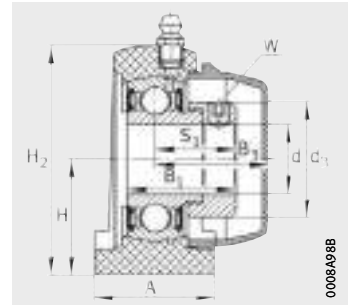

SUGPPA

					Width across flats W	Load carrying capacity			
						Bearing			Housing C <sub>0rG</sub> N
B	B <sub>3</sub>	K	S <sub>1</sub>	Q		Basic load ratings		Fatigue limit load	
					dyn. C <sub>r</sub> N	stat. C <sub>0r</sub> N	C <sub>ur</sub> N		
26	31,65	M8	18	1/4" - 28 UNF	2,5	12 300	6 300	300	6 900
31	31,65	M8	18,3	1/4" - 28 UNF	2,5	12 300	6 300	300	6 900
28	34,05	M10	19,5	1/4" - 28 UNF	2,5	13 400	7 500	360	7 000
34,1	34,05	M10	19,8	1/4" - 28 UNF	2,5	13 400	7 500	360	7 000
30,5	39,95	M10	21	1/4" - 28 UNF	3	18 700	10 700	510	6 500
38,1	39,95	M10	22,2	1/4" - 28 UNF	3	18 700	10 700	510	6 500
35,45	44,85	M10	25,45	1/4" - 28 UNF	3	24 600	14 600	700	8 000
42,9	44,85	M10	25,4	1/4" - 28 UNF	3	24 600	14 600	700	8 000
39,45	51,5	M12	28,95	1/4" - 28 UNF	4	31 500	18 900	910	9 100
49,2	51,5	M12	30,2	1/4" - 28 UNF	4	31 500	18 900	910	9 100
41,5	53,7	M12	30,5	1/4" - 28 UNF	4	31 500	19 400	930	10 400
49,2	53,7	M12	30,2	1/4" - 28 UNF	4	31 500	19 400	930	10 400
43,5	60,9	M16	32	1/4" - 28 UNF	5	33 500	22 100	1 060	11 000
51,6	60,9	M16	32,6	1/4" - 28 UNF	5	33 500	22 100	1 060	11 000

						Width across flats W	Load carrying capacity			
							Bearing			Housing C <sub>0rG</sub> N
B <sub>1</sub>	B <sub>3</sub>	K	S <sub>1</sub>	Q	d <sub>3</sub> max.		Basic load ratings		Fatigue limit load	
						dyn. C <sub>r</sub> N	stat. C <sub>0r</sub> N	C <sub>ur</sub> N		
31,5	31,65	M8	23,5	1/4" - 28 UNF	33	3	12 300	6 300	300	6 900
32	34,05	M10	23,5	1/4" - 28 UNF	37,5	3	13 400	7 500	360	7 000
36,3	39,95	M10	26,8	1/4" - 28 UNF	44	4	18 700	10 700	510	6 500
39,5	44,85	M10	29,5	1/4" - 28 UNF	55	5	24 600	14 600	700	8 000
43,8	51,5	M12	32,8	1/4" - 28 UNF	58	5	31 500	18 900	910	9 100
43,8	53,7	M12	32,8	1/4" - 28 UNF	63	5	31 500	19 400	930	10 400
44,3	60,9	M16	32,8	1/4" - 28 UNF	69	5	33 500	22 100	1 060	11 000



# Plummer block housing units

- Plastic housing
- With short base
- Radial insert ball bearing with Corrotect coating
- With eccentric locking collar

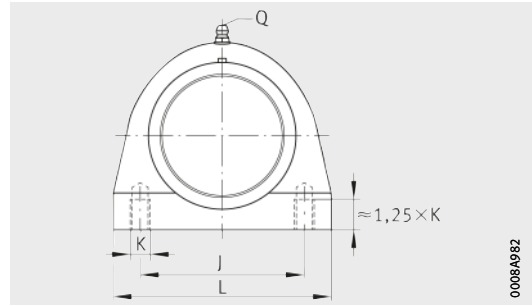

CUGPPA

00084982

**Dimension table** - Dimensions in mm

Designation			Mass m ≈ kg	Dimensions				
Unit <sup>1)</sup>	Housing	Radial insert ball bearing		d	H	J	L	A
<b>CUGPPA204</b>	GEHPPA204	GRAE20-XL-NPP-B-FA107/125	0,3	<b>20</b>	33,3	50,8	72,8	34,5
<b>CUGPPA205</b>	GEHPPA205	GRAE25-XL-NPP-B-FA107/125	0,35	<b>25</b>	36,5	50,8	76,2	39,5
<b>CUGPPA206</b>	GEHPPA206	GRAE30-XL-NPP-B-FA107/125	0,57	<b>30</b>	42,9	76,2	101	42,5
<b>CUGPPA207</b>	GEHPPA207	GRAE35-XL-NPP-B-FA107/125	0,85	<b>35</b>	47,6	82,6	110	47,5
<b>CUGPPA208</b>	GEHPPA208	GRAE40-XL-NPP-B-FA107/125	0,99	<b>40</b>	49,2	88,9	120	48
<b>CUGPPA209<sup>2)</sup></b>	GEHPPA209	GRAE45-XL-NPP-B-FA107/125	1,12	<b>45</b>	54	95,3	124	50
<b>CUGPPA210<sup>2)</sup></b>	GEHPPA210	GRAE50-XL-NPP-B-FA107/125	1,22	<b>50</b>	57,2	101,6	135	54

<sup>1)</sup> Available end caps, see page 435.

<sup>2)</sup> Available by agreement.

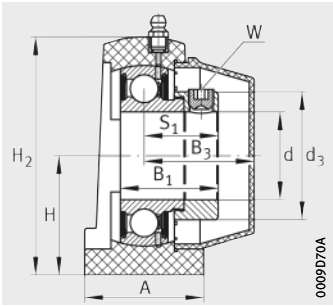

CUGPPA

							Width across flats W	Load carrying capacity			
								Bearing			Housing $C_{0rG}$ N
							Basic load ratings		Fatigue limit load $C_{ur}$ N		
$H_2$	$B_1$	$B_3$	K	$S_1$	Q	$d_3$ max.	dyn. $C_r$ N	stat. $C_{0r}$ N			
66	31	31,65	M8	23,5	$1/4'' - 28 \text{ UNF}$	33	3	13 600	6 600	335	6 900
73,5	31	34,05	M10	23,5	$1/4'' - 28 \text{ UNF}$	37,5	3	14 900	7 800	395	7 000
84	35,8	39,95	M10	26,8	$1/4'' - 28 \text{ UNF}$	44	4	20 700	11 300	570	6 500
95	39	44,85	M10	29,5	$1/4'' - 28 \text{ UNF}$	55	5	27 500	15 300	770	8 000
100,5	43,8	51,5	M12	32,8	$1/4'' - 28 \text{ UNF}$	58	5	34 500	19 800	1 010	9 100
108,5	43,8	53,7	M12	32,8	$1/4'' - 28 \text{ UNF}$	63	5	34 500	20 400	1 030	10 400
115	43,8	60,9	M16	32,8	$1/4'' - 28 \text{ UNF}$	69	5	37 500	23 200	1 180	11 000



# Two-bolt flanged housing units

Plastic housing

Narrow version

Radial insert ball bearing in corrosion-resistant VA design

With grub screw or eccentric locking collar

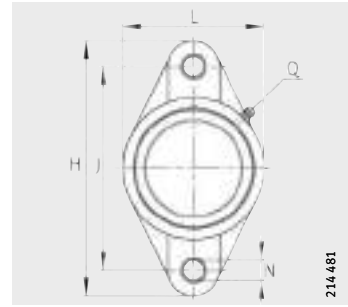

SUBPFL, SUCPFL, SUGPFL

**Dimension table** - Dimensions in mm

Designation			Mass m ≈ kg	Dimensions							
Unit <sup>1)</sup>	Housing	Radial insert ball bearing		d	H	J	L	A	A <sub>1</sub>	A <sub>2</sub>	N
<b>SUBPFL204</b>	GEHPFL204	SUB204	0,23	<b>20</b>	114	90	64,8	26,5	11,4	15,4	11
<b>SUCPFL204</b>	GEHPFL204	SUC204	0,26	<b>20</b>	114	90	64,8	26,5	11,4	15,4	11
<b>SUBPFL205</b>	GEHPFL205	SUB205	0,29	<b>25</b>	130	99	70	29,1	13,5	17	11
<b>SUCPFL205</b>	GEHPFL205	SUC205	0,32	<b>25</b>	130	99	70	29,1	13,5	17	11
<b>SUBPFL206</b>	GEHPFL206	SUB206	0,41	<b>30</b>	148	117	80	30,5	13,3	18	11
<b>SUCPFL206</b>	GEHPFL206	SUC206	0,45	<b>30</b>	148	117	80	30,5	13,3	18	11
<b>SUBPFL207</b>	GEHPFL207	SUB207	0,6	<b>35</b>	163	130	90	32,8	16,1	18	13
<b>SUCPFL207</b>	GEHPFL207	SUC207	0,66	<b>35</b>	163	130	90	32,8	16,1	18	13
<b>SUBPFL208</b>	GEHPFL208	SUB208	0,78	<b>40</b>	175	144	100	37,5	20	21,5	14
<b>SUCPFL208</b>	GEHPFL208	SUC208	0,88	<b>40</b>	175	144	100	37,5	20	21,5	14
<b>SUBPFL209</b>	GEHPFL209	SUB209	0,91	<b>45</b>	188,5	148,5	108	41	21	24	17
<b>SUCPFL209<sup>2)</sup></b>	GEHPFL209	SUC209	1	<b>45</b>	188,5	148,5	108	41	21	24	17
<b>SUBPFL210</b>	GEHPFL210	SUB210	1,02	<b>50</b>	197	157	115	43	21	25	17
<b>SUCPFL210<sup>2)</sup></b>	GEHPFL210	SUC210	1,16	<b>50</b>	197	157	115	43	21	25	17

**Dimension table** - Dimensions in mm

Designation			Mass m ≈ kg	Dimensions							
Unit <sup>1)3)</sup>	Housing	Radial insert ball bearing		d	H	J	L	A	A <sub>1</sub>	A <sub>2</sub>	N
<b>SUGPFL204</b>	GEHPFL204	SUG204	0,27	<b>20</b>	114	90	64,8	26,5	11,4	15,4	11
<b>SUGPFL205</b>	GEHPFL205	SUG205	0,31	<b>25</b>	130	99	70	29,1	13,5	17	11
<b>SUGPFL206</b>	GEHPFL206	SUG206	0,45	<b>30</b>	148	117	80	30,5	13,3	18	11
<b>SUGPFL207</b>	GEHPFL207	SUG207	0,68	<b>35</b>	163	130	90	32,8	16,1	18	13
<b>SUGPFL208</b>	GEHPFL208	SUG208	0,84	<b>40</b>	175	144	100	37,5	20	21,5	14
<b>SUGPFL209<sup>2)</sup></b>	GEHPFL209	SUG209	1,01	<b>45</b>	188,5	148,5	108	41	21	24	17
<b>SUGPFL210<sup>2)</sup></b>	GEHPFL210	SUG210	1,12	<b>50</b>	197	157	115	43	21	25	17

<sup>1)</sup> Available end caps, see page 435.

<sup>2)</sup> Available by agreement.

<sup>3)</sup> For these series, Back Seal components are also available, see page 436.



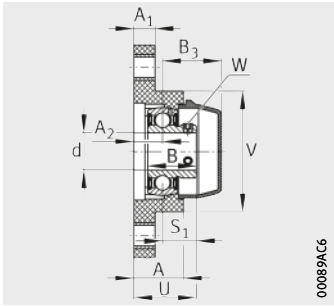

SUBPFL

00089AC6

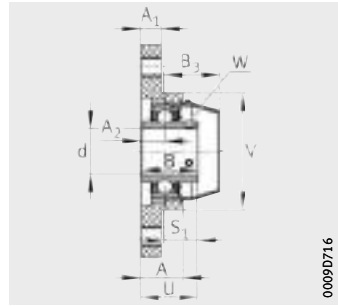

SUCPFL

0009D716

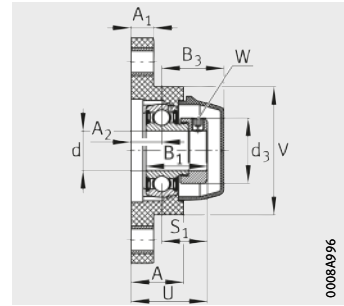

SUGPFL

0008A996

						Width across flats  W	Load carrying capacity			
							Bearing			Housing  C <sub>OrG</sub>  N
							Basic load ratings		Fatigue limit load	
B	B <sub>3</sub>	S <sub>1</sub>	U	V	Q		dyn. C <sub>r</sub> N	stat. C <sub>Or</sub> N	C <sub>ur</sub> N	C <sub>OrG</sub> N
26	31,4	18	33,4	64,8	1/4" - 28 UNF	2,5	12 300	6 300	300	8 500
31	31,4	18,3	33,7	64,8	1/4" - 28 UNF	2,5	12 300	6 300	300	8 500
28	34,1	19,5	36,5	70	1/4" - 28 UNF	2,5	13 400	7 500	360	11 100
34,1	34,1	19,8	36,8	70	1/4" - 28 UNF	2,5	13 400	7 500	360	11 100
30,5	38,5	21	39	80	1/4" - 28 UNF	3	18 700	10 700	510	14 200
38,1	38,5	22,2	40,2	80	1/4" - 28 UNF	3	18 700	10 700	510	14 200
35,45	43,6	25,45	43,45	90	1/4" - 28 UNF	3	24 600	14 600	700	14 900
42,9	43,6	25,4	43,4	90	1/4" - 28 UNF	3	24 600	14 600	700	14 900
39,45	49,5	28,95	50,45	100	1/4" - 28 UNF	4	31 500	18 900	910	14 900
49,2	49,5	30,2	51,7	100	1/4" - 28 UNF	4	31 500	18 900	910	14 900
41,5	53,7	30,5	54,5	108	1/4" - 28 UNF	4	31 500	19 400	930	15 100
49,2	53,7	30,2	54,2	108	1/4" - 28 UNF	4	31 500	19 400	930	15 100
43,5	60,3	32	57	115	1/4" - 28 UNF	5	33 500	22 100	1 060	15 600
51,6	60,3	32,6	57,6	115	1/4" - 28 UNF	5	33 500	22 100	1 060	15 600

							Width across flats  W	Load carrying capacity			
								Bearing			Housing  C <sub>OrG</sub>  N
								Basic load ratings		Fatigue limit load	
B <sub>1</sub>	B <sub>3</sub>	S <sub>1</sub>	U	V	Q	d <sub>3</sub> max.		dyn. C <sub>r</sub> N	stat. C <sub>Or</sub> N	C <sub>ur</sub> N	C <sub>OrG</sub> N
31,5	31,4	23,5	38,9	64,8	1/4" - 28 UNF	33	3	12 300	6 300	300	8 500
32	34,1	23,5	40,5	70	1/4" - 28 UNF	37,5	3	13 400	7 500	360	11 100
36,3	38,5	26,8	44,8	80	1/4" - 28 UNF	44	4	18 700	10 700	510	14 200
39,5	43,6	29,5	47,5	90	1/4" - 28 UNF	55	5	24 600	14 600	700	14 900
43,8	49,5	32,8	54,3	100	1/4" - 28 UNF	58	5	31 500	18 900	910	14 900
43,8	53,7	32,8	56,8	108	1/4" - 28 UNF	63	5	31 500	19 400	930	15 100
44,3	60,3	32,8	57,8	115	1/4" - 28 UNF	69	5	33 500	22 100	1 060	15 600



# Two-bolt flanged housing units

Plastic housing  
 Narrow version  
 Radial insert ball bearing with Corrotect coating  
 With eccentric locking collar

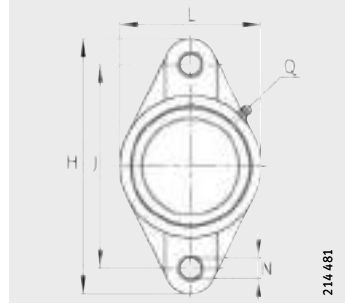

CUGPFL

**Dimension table** - Dimensions in mm

Designation			Mass m ≈ kg	Dimensions						
Unit <sup>1)2)</sup>	Housing	Radial insert ball bearing		d	H	J	L	A	A <sub>1</sub>	A <sub>2</sub>
<b>CUGPFL204</b>	GEHPFL204	GRAE20-XL-NPP-B-FA107/125	0,27	<b>20</b>	114	90	64,8	26,5	11,4	15,4
<b>CUGPFL205</b>	GEHPFL205	GRAE25-XL-NPP-B-FA107/125	0,33	<b>25</b>	130	99	70	29,1	13,5	17
<b>CUGPFL206</b>	GEHPFL206	GRAE30-XL-NPP-B-FA107/125	0,49	<b>30</b>	148	117	80	30,5	13,3	18
<b>CUGPFL207</b>	GEHPFL207	GRAE35-XL-NPP-B-FA107/125	0,74	<b>35</b>	163	130	90	32,8	16,1	18
<b>CUGPFL208</b>	GEHPFL208	GRAE40-XL-NPP-B-FA107/125	0,93	<b>40</b>	175	144	100	37,5	20	21,5
<b>CUGPFL209<sup>3)</sup></b>	GEHPFL209	GRAE45-XL-NPP-B-FA107/125	1,09	<b>45</b>	188,5	148,5	108	41	21	24
<b>CUGPFL210<sup>3)</sup></b>	GEHPFL210	GRAE50-XL-NPP-B-FA107/125	1,18	<b>50</b>	197	157	115	43	21	25

1) Available end caps, see page 435.

2) For these series, Back Seal components are also available, see page 436.

3) Available by agreement.

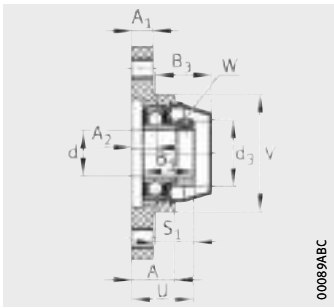

00089ABC

CUGPFL

								Width across flats  W	Load carrying capacity			
									Bearing			Housing  C <sub>OrG</sub>  N
									Basic load ratings		Fatigue limit load	
N	B <sub>1</sub>	B <sub>3</sub>	S <sub>1</sub>	U	V	Q	d <sub>3</sub> max.		dyn. C <sub>r</sub> N	stat. C <sub>Or</sub> N	C <sub>ur</sub> N	
11	31	31,4	23,5	38,9	64,8	1/4" – 28 UNF	33	3	13 600	6 600	335	8 500
11	31	34,1	23,5	40,5	70	1/4" – 28 UNF	37,5	3	14 900	7 800	395	11 100
11	35,8	38,5	26,8	44,8	80	1/4" – 28 UNF	44	4	20 700	11 300	570	14 200
13	39	43,6	29,5	47,5	90	1/4" – 28 UNF	55	5	27 500	15 300	770	14 900
14	43,8	49,5	32,8	54,3	100	1/4" – 28 UNF	58	5	34 500	19 800	1 010	14 900
17	43,8	53,7	32,8	56,8	108	1/4" – 28 UNF	63	5	34 500	20 400	1 030	15 100
17	43,8	60,3	32,8	57,8	115	1/4" – 28 UNF	69	5	37 500	23 200	1 180	15 600



# Two-bolt flanged housing units

Plastic housing

Wide version

Radial insert ball bearing in corrosion-resistant VA design

With grub screw or eccentric locking collar

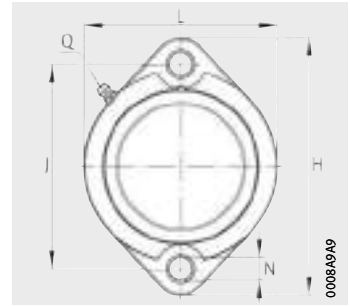

SUBPCTL, SUGPCTL

**Dimension table** - Dimensions in mm

Designation			Mass m ≈ kg	Dimensions						
Unit <sup>1)</sup>	Housing	Radial insert ball bearing		d	H	J	L	A <sub>1</sub>	A <sub>2</sub>	N
<b>SUBPCTL204</b>	GEHPCTL204	SUB204	0,22	<b>20</b>	90,5	71,4	66,5	18,4	9,5	9,2
<b>SUBPCTL205</b>	GEHPCTL205	SUB205	0,25	<b>25</b>	97	76,2	71	18,4	9,9	9,2
<b>SUBPCTL206</b>	GEHPCTL206	SUB206	0,37	<b>30</b>	112	90,5	84	20,5	11,4	11
<b>SUBPCTL207</b>	GEHPCTL207	SUB207	0,55	<b>35</b>	126	100	94	22,5	12,4	11
<b>SUBPCTL208</b>	GEHPCTL208	SUB208	0,7	<b>40</b>	150	119	100	24	13,5	14

**Dimension table** - Dimensions in mm

Designation			Mass m ≈ kg	Dimensions						
Unit <sup>1)</sup>	Housing	Radial insert ball bearing		d	H	J	L	A <sub>1</sub>	A <sub>2</sub>	N
<b>SUGPCTL204</b>	GEHPCTL204	SUG204	0,25	<b>20</b>	90,5	71,4	66,5	18,4	9,5	9,2
<b>SUGPCTL205</b>	GEHPCTL205	SUG205	0,28	<b>25</b>	97	76,2	71	18,4	9,9	9,2
<b>SUGPCTL206</b>	GEHPCTL206	SUG206	0,42	<b>30</b>	112	90,5	84	20,5	11,4	11
<b>SUGPCTL207</b>	GEHPCTL207	SUG207	0,66	<b>35</b>	126	100	94	22,5	12,4	11
<b>SUGPCTL208</b>	GEHPCTL208	SUG208	0,79	<b>40</b>	150	119	100	24	13,5	14

<sup>1)</sup> Available end caps, see page 435.

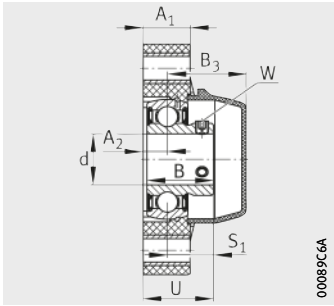

SUBPCTL

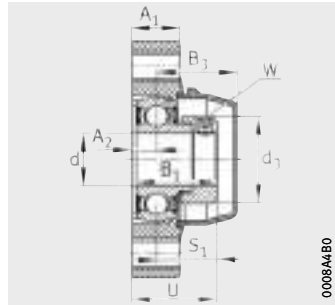

SUGPCTL

					Width across flats	Load carrying capacity			
						W	Bearing		
					Basic load ratings		Fatigue limit load	$C_{0rG}$	
B	$B_3$	$S_1$	U	Q	dyn. $C_r$				stat. $C_{0r}$
26	30,8	18	27,5	1/4" - 28 UNF	2,5	12 300	6 300	300	7 200
28	33,5	19,5	29,4	1/4" - 28 UNF	2,5	13 400	7 500	360	9 400
30,5	38,6	21	32,4	1/4" - 28 UNF	3	18 700	10 700	510	12 000
35,45	41,1	25,45	37,85	1/4" - 28 UNF	3	24 600	14 600	700	12 600
39,45	47,5	28,95	42,45	1/4" - 28 UNF	4	31 500	18 900	910	12 800

						Width across flats	Load carrying capacity			
							W	Bearing		
						Basic load ratings		Fatigue limit load	$C_{0rG}$	
$B_1$	$B_3$	$S_1$	U	Q	$d_3$	dyn. $C_r$				stat. $C_{0r}$
31,5	30,8	23,5	33	1/4" - 28 UNF	33	3	12 300	6 300	300	7 200
32	33,5	23,5	33,4	1/4" - 28 UNF	37,5	3	13 400	7 500	360	9 400
36,3	38,6	26,8	38,2	1/4" - 28 UNF	44	4	18 700	10 700	510	12 000
39,5	41,1	29,5	41,9	1/4" - 28 UNF	55	5	24 600	14 600	700	12 600
43,8	47,5	32,8	46,3	1/4" - 28 UNF	58	5	31 500	18 900	910	12 800



## Two-bolt flanged housing units

Plastic housing

Wide version

Radial insert ball bearing with Corrotect coating

With eccentric locking collar

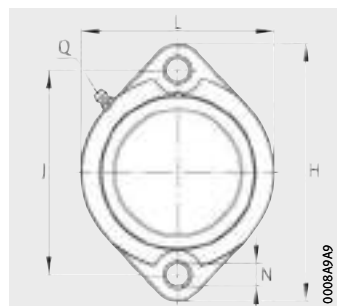

CUGPCTL

**Dimension table** - Dimensions in mm

Designation			Mass	Dimensions					
Unit <sup>1)</sup>	Housing	Radial insert ball bearing		d	H	J	L	A <sub>1</sub>	A <sub>2</sub>
			m ≈ kg						
<b>CUGPCTL204</b>	GEHPCTL204	GRAE20-XL-NPP-B-FA107/125	0,26	<b>20</b>	90,5	71,4	66,5	18,4	9,5
<b>CUGPCTL205</b>	GEHPCTL205	GRAE25-XL-NPP-B-FA107/125	0,29	<b>25</b>	97	76,2	71	18,4	9,9
<b>CUGPCTL206</b>	GEHPCTL206	GRAE30-XL-NPP-B-FA107/125	0,47	<b>30</b>	112	90,5	84	20,5	11,4
<b>CUGPCTL207</b>	GEHPCTL207	GRAE35-XL-NPP-B-FA107/125	0,71	<b>35</b>	126	100	94	22,5	12,4
<b>CUGPCTL208</b>	GEHPCTL208	GRAE40-XL-NPP-B-FA107/125	0,86	<b>40</b>	150	119	100	24	13,5

<sup>1)</sup> Available end caps, see page 435.

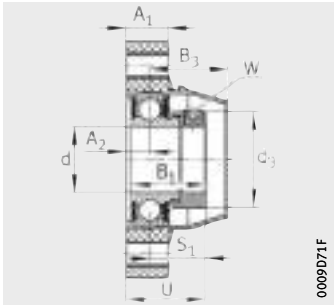

0009071F

CUGPCTL

							Width across flats W	Load carrying capacity			
								Bearing			Housing C <sub>0rG</sub> N
							Basic load ratings		Fatigue limit load C <sub>ur</sub> N		
N	B <sub>1</sub>	B <sub>3</sub>	S <sub>1</sub>	U	Q	d <sub>3</sub> max.	dyn. C <sub>r</sub> N	stat. C <sub>0r</sub> N			
9,2	31	30,8	23,5	33	1/4" – 28 UNF	33	3	13 600	6 600	335	7 200
9,2	31	33,5	23,5	33,4	1/4" – 28 UNF	37,5	3	14 900	7 800	395	9 400
11	35,8	38,6	26,8	38,2	1/4" – 28 UNF	44	4	20 700	11 300	570	12 000
11	39	41,1	29,5	41,9	1/4" – 28 UNF	55	5	27 500	15 300	770	12 600
14	43,8	47,5	32,8	46,3	1/4" – 28 UNF	58	5	34 500	19 800	1 010	12 800



# Four-bolt flanged housing units

Plastic housing

Radial insert ball bearing in corrosion-resistant VA design

With grub screw or eccentric locking collar

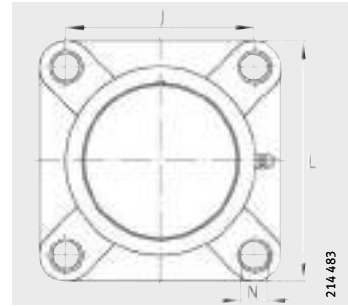

SUBPF, SUCPF, SUGPF

**Dimension table** - Dimensions in mm

Designation			Mass m ≈ kg	Dimensions							
Unit <sup>1)</sup>	Housing	Radial insert ball bearing		d	J	L	A	A <sub>1</sub>	A <sub>2</sub>	N	B
<b>SUBPF204</b>	GEHPF204	SUB204	0,29	<b>20</b>	63,5	87	27,8	13,4	18	11	26
<b>SUCPF204</b>	GEHPF204	SUC204	0,31	<b>20</b>	63,5	87	27,8	13,4	18	11	31
<b>SUBPF205</b>	GEHPF205	SUB205	0,34	<b>25</b>	70	94,5	27,9	14,3	17	11	28
<b>SUCPF205</b>	GEHPF205	SUC205	0,38	<b>25</b>	70	94,5	27,9	14,3	17	11	34,1
<b>SUBPF206</b>	GEHPF206	SUB206	0,48	<b>30</b>	83	107	31,5	14,3	19,2	11	30,5
<b>SUCPF206</b>	GEHPF206	SUC206	0,52	<b>30</b>	83	107	31,5	14,3	19,2	11	38,1
<b>SUBPF207</b>	GEHPF207	SUB207	0,68	<b>35</b>	92	117	34,8	15,5	21,5	13	35,45
<b>SUCPF207</b>	GEHPF207	SUC207	0,74	<b>35</b>	92	117	34,8	15,5	21,5	13	42,9
<b>SUBPF208</b>	GEHPF208	SUB208	0,89	<b>40</b>	102	130	37,5	17	23	14	39,45
<b>SUCPF208</b>	GEHPF208	SUC208	0,98	<b>40</b>	102	130	37,5	17	23	14	49,2
<b>SUBPF209<sup>2)</sup></b>	GEHPF209	SUB209	1	<b>45</b>	105	137	41	19	24	17	41,5
<b>SUCPF209<sup>2)</sup></b>	GEHPF209	SUC209	1,1	<b>45</b>	105	137	41	19	24	17	49,2
<b>SUBPF210<sup>2)</sup></b>	GEHPF210	SUB210	1,16	<b>50</b>	111	143	43	21	25	17	43,5
<b>SUCPF210<sup>2)</sup></b>	GEHPF210	SUC210	1,31	<b>50</b>	111	143	43	21	25	17	51,6

**Dimension table** - Dimensions in mm

Designation			Mass m ≈ kg	Dimensions							
Unit <sup>1)3)</sup>	Housing	Radial insert ball bearing		d	J	L	A	A <sub>1</sub>	A <sub>2</sub>	N	B <sub>1</sub>
<b>SUGPF204</b>	GEHPF204	SUG204	0,32	<b>20</b>	63,5	87	27,8	13,4	18	11	31,5
<b>SUGPF205</b>	GEHPF205	SUG205	0,36	<b>25</b>	70	94,5	27,9	14,3	17	11	32
<b>SUGPF206</b>	GEHPF206	SUG206	0,51	<b>30</b>	83	107	31,5	14,3	19,2	11	36,3
<b>SUGPF207</b>	GEHPF207	SUG207	0,76	<b>35</b>	92	117	34,8	15,5	21,5	13	39,5
<b>SUGPF208</b>	GEHPF208	SUG208	0,94	<b>40</b>	102	130	37,5	17	23	14	43,8
<b>SUGPF209<sup>2)</sup></b>	GEHPF209	SUG209	1,1	<b>45</b>	105	137	41	19	24	17	43,8
<b>SUGPF210<sup>2)</sup></b>	GEHPF210	SUG210	1,26	<b>50</b>	111	143	43	21	25	17	44,3

<sup>1)</sup> Available end caps, see page 435.

<sup>2)</sup> Available by agreement.

<sup>3)</sup> For these series, Back Seal components are also available, see page 436.



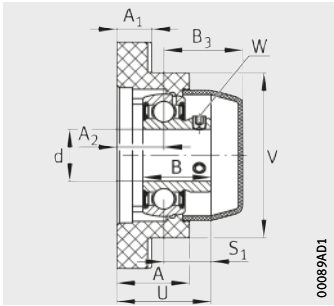

SUBPF

00089AD1

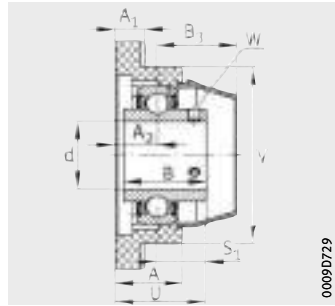

SUCPF

0009D729

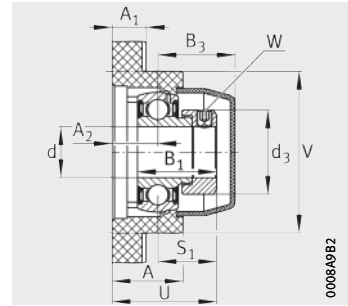

SUGPF

0008A9B2

					Width across flats W	Load carrying capacity			
						Bearing			Housing C <sub>0rG</sub> N
					Basic load ratings		Fatigue limit load C <sub>ur</sub> N		
B <sub>3</sub>	S <sub>1</sub>	U	V	Q	dyn. C <sub>r</sub> N	stat. C <sub>0r</sub> N			
30,2	18	36	63,5	1/4" - 28 UNF	2,5	12 300	6 300	300	10 200
30,2	18,3	36,3	63,5	1/4" - 28 UNF	2,5	12 300	6 300	300	10 200
33,1	19,5	36,5	70	1/4" - 28 UNF	2,5	13 400	7 500	360	12 100
33,1	19,8	36,8	70	1/4" - 28 UNF	2,5	13 400	7 500	360	12 100
39,5	21	40,2	80	1/4" - 28 UNF	3	18 700	10 700	510	17 700
39,5	22,2	41,4	80	1/4" - 28 UNF	3	18 700	10 700	510	17 700
42,1	25,45	46,95	90	1/4" - 28 UNF	3	24 600	14 600	700	18 500
42,1	25,4	46,9	90	1/4" - 28 UNF	3	24 600	14 600	700	18 500
48	28,95	51,95	99	1/4" - 28 UNF	4	31 500	18 900	910	19 200
48	30,2	53,2	99	1/4" - 28 UNF	4	31 500	18 900	910	19 200
53,7	30,5	54,5	105	1/4" - 28 UNF	4	31 500	19 400	930	19 300
53,7	30,2	54,2	105	1/4" - 28 UNF	4	31 500	19 400	930	19 300
60,7	32	57	115	1/4" - 28 UNF	5	33 500	22 100	1 060	19 600
60,7	32,6	57,6	115	1/4" - 28 UNF	5	33 500	22 100	1 060	19 600

						Width across flats W	Load carrying capacity			
							Bearing			Housing C <sub>0rG</sub> N
						Basic load ratings		Fatigue limit load C <sub>ur</sub> N		
B <sub>3</sub>	S <sub>1</sub>	U	V	Q	d <sub>3</sub> max.	dyn. C <sub>r</sub> N	stat. C <sub>0r</sub> N			
30,2	23,5	41,5	63,5	1/4" - 28 UNF	33	3	12 300	6 300	300	10 200
33,1	23,5	40,5	70	1/4" - 28 UNF	37,5	3	13 400	7 500	360	12 100
39,5	26,8	46	80	1/4" - 28 UNF	44	4	18 700	10 700	510	17 700
42,1	29,5	51	90	1/4" - 28 UNF	55	5	24 600	14 600	700	18 500
48	32,8	55,8	99	1/4" - 28 UNF	58	5	31 500	18 900	910	19 200
53,7	32,8	56,8	105	1/4" - 28 UNF	63	5	31 500	19 400	930	19 300
60,7	32,8	57,8	115	1/4" - 28 UNF	69	5	33 500	22 100	1 060	19 600



# Four-bolt flanged housing units

Plastic housing  
 Radial insert ball bearing with Corrotect coating  
 With eccentric locking collar

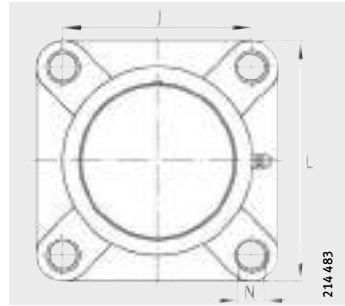

CUGPF

**Dimension table** - Dimensions in mm

Designation			Mass	Dimensions						
Unit <sup>1)2)</sup>	Housing	Radial insert ball bearing		d	J	L	A	A <sub>1</sub>	A <sub>2</sub>	N
			m ≈ kg							
<b>CUGPF204</b>	GEHPF204	GRAE20-XL-NPP-B-FA107/125	0,33	<b>20</b>	63,5	87	27,8	13,4	18	11
<b>CUGPF205</b>	GEHPF205	GRAE25-XL-NPP-B-FA107/125	0,39	<b>25</b>	70	94,5	27,9	14,3	17	11
<b>CUGPF206</b>	GEHPF206	GRAE30-XL-NPP-B-FA107/125	0,57	<b>30</b>	83	107	31,5	14,3	19,2	11
<b>CUGPF207</b>	GEHPF207	GRAE35-XL-NPP-B-FA107/125	0,85	<b>35</b>	92	117	34,8	15,5	21,5	13
<b>CUGPF208</b>	GEHPF208	GRAE40-XL-NPP-B-FA107/125	1,07	<b>40</b>	102	130	37,5	17	23	14
<b>CUGPF209<sup>3)</sup></b>	GEHPF209	GRAE45-XL-NPP-B-FA107/125	1,2	<b>45</b>	105	137	41	19	24	17
<b>CUGPF210<sup>3)</sup></b>	GEHPF210	GRAE50-XL-NPP-B-FA107/125	1,32	<b>50</b>	111	143	43	21	25	17

1) Available end caps, see page 435.

2) For these series, Back Seal components are also available, see page 436.

3) Available by agreement.

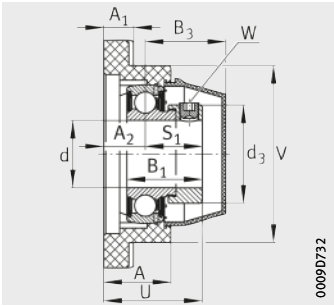

00090732

CUGPF

							Width across flats  W	Load carrying capacity			
								Bearing			Housing  C <sub>0rG</sub>  N
								Basic load ratings		Fatigue limit load	
B <sub>1</sub>	B <sub>3</sub>	S <sub>1</sub>	U	V	Q	d <sub>3</sub> max.	dyn. C <sub>r</sub> N	stat. C <sub>0r</sub> N	C <sub>ur</sub> N	C <sub>0rG</sub> N	
31	30,2	23,5	41,5	63,5	1/4" - 28 UNF	33	3	13 600	6 600	335	10 200
31	33,1	23,5	40,5	70	1/4" - 28 UNF	37,5	3	14 900	7 800	395	12 100
35,8	39,5	26,8	46	80	1/4" - 28 UNF	44	4	20 700	11 300	570	17 700
39	42,1	29,5	51	90	1/4" - 28 UNF	55	5	27 500	15 300	770	18 500
43,8	48	32,8	55,8	99	1/4" - 28 UNF	58	5	34 500	19 800	1 010	19 200
43,8	53,7	32,8	56,8	105	1/4" - 28 UNF	63	5	34 500	20 400	1 030	19 300
43,8	60,7	32,8	57,8	115	1/4" - 28 UNF	69	5	37 500	23 200	1 180	19 600



# Take-up housing units

- Plastic housing
- Guide slots on both sides
- Hole for threaded rod
- Radial insert ball bearing in corrosion-resistant VA design
- With grub screw or eccentric locking collar

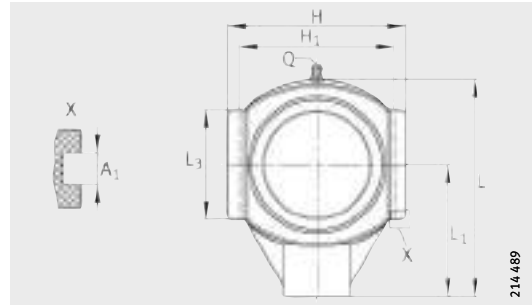

SUBPT, SUCPT, SUGPT

**Dimension table** - Dimensions in mm

Designation			Mass	Dimensions							
Unit <sup>1)</sup>	Housing	Radial insert ball bearing		m ≈ kg	d	H	L	L <sub>1</sub>	L <sub>3</sub>	A <sub>1</sub>	A <sub>2</sub>
<b>SUBPT204</b>	GEHPT204	SUB204	0,35	<b>20</b>	89	99	64	46	12	27,5	76
<b>SUCPT204</b>	GEHPT204	SUC204	0,37	<b>20</b>	89	99	64	46	12	27,5	76
<b>SUBPT205</b>	GEHPT205	SUB205	0,37	<b>25</b>	89	99	64	46	12	27,5	76
<b>SUCPT205</b>	GEHPT205	SUC205	0,4	<b>25</b>	89	99	64	46	12	27,5	76
<b>SUBPT206</b>	GEHPT206	SUB206	0,62	<b>30</b>	102,5	125	76	63,5	12	34	89
<b>SUCPT206</b>	GEHPT206	SUC206	0,65	<b>30</b>	102,5	125	76	63,5	12	34	89
<b>SUBPT207</b>	GEHPT207	SUB207	0,71	<b>35</b>	102,5	125	76	63,5	12	34	89
<b>SUCPT207</b>	GEHPT207	SUC207	0,77	<b>35</b>	102,5	125	76	63,5	12	34	89
<b>SUBPT208</b>	GEHPT208	SUB208	0,9	<b>40</b>	114	140	85	80	16	34	102
<b>SUCPT208</b>	GEHPT208	SUC208	1	<b>40</b>	114	140	85	80	16	34	102
<b>SUBPT209<sup>2)</sup></b>	GEHPT209	SUB209	1,09	<b>45</b>	117	149	90	85	16	40	102
<b>SUCPT209<sup>2)</sup></b>	GEHPT209	SUC209	1,16	<b>45</b>	117	149	90	85	16	40	102
<b>SUBPT210<sup>2)</sup></b>	GEHPT210	SUB210	1,21	<b>50</b>	117	149	90	85	16	40	102
<b>SUCPT210<sup>2)</sup></b>	GEHPT210	SUC210	1,32	<b>50</b>	117	149	90	85	16	40	102

**Dimension table** - Dimensions in mm

Designation			Mass	Dimensions							
Unit <sup>1)</sup>	Housing	Radial insert ball bearing		m ≈ kg	d	H	L	L <sub>1</sub>	L <sub>3</sub>	A <sub>1</sub>	A <sub>2</sub>
<b>SUGPT204</b>	GEHPT204	SUG204	0,38	<b>20</b>	89	99	64	46	12	27,5	76
<b>SUGPT205</b>	GEHPT205	SUG205	0,4	<b>25</b>	89	99	64	46	12	27,5	76
<b>SUGPT206</b>	GEHPT206	SUG206	0,67	<b>30</b>	102,5	125	76	63,5	12	34	89
<b>SUGPT207</b>	GEHPT207	SUG207	0,81	<b>35</b>	102,5	125	76	63,5	12	34	89
<b>SUGPT208</b>	GEHPT208	SUG208	0,98	<b>40</b>	114	140	85	80	16	34	102
<b>SUGPT209<sup>2)</sup></b>	GEHPT209	SUG209	1,19	<b>45</b>	117	149	90	85	16	40	102
<b>SUGPT210<sup>2)</sup></b>	GEHPT210	SUG210	1,31	<b>50</b>	117	149	90	85	16	40	102

<sup>1)</sup> Available end caps, see page 435.

<sup>2)</sup> Available by agreement.

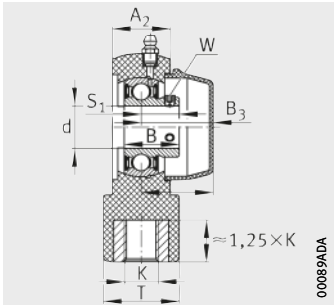

SUBPT

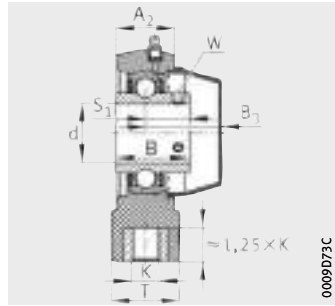

SUCPT

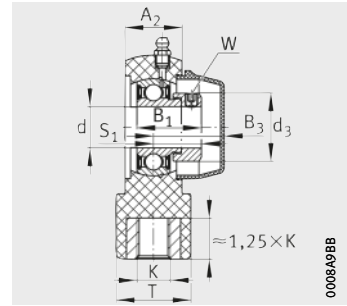

SUGPT

						Width across flats	Load carrying capacity			
							W	Bearing		
						Basic load ratings		Fatigue limit load	C <sub>OrG</sub> N	
B	B <sub>3</sub>	K	T	S <sub>1</sub>	Q	dyn. C <sub>r</sub> N				stat. C <sub>Or</sub> N
26	34,05	M16	36	18	1/4" - 28 UNF	2,5	12 300	6 300	300	9 600
31	34,05	M16	36	18,3	1/4" - 28 UNF	2,5	12 300	6 300	300	9 600
28	35,95	M16	36	19,5	1/4" - 28 UNF	2,5	13 400	7 500	360	10 000
34,1	35,95	M16	36	19,8	1/4" - 28 UNF	2,5	13 400	7 500	360	10 000
30,5	43,5	M16	40	21	1/4" - 28 UNF	3	18 700	10 700	510	10 200
38,1	43,5	M16	40	22,2	1/4" - 28 UNF	3	18 700	10 700	510	10 200
35,45	45,2	M16	40	25,45	1/4" - 28 UNF	3	24 600	14 600	700	10 700
42,9	45,2	M16	40	25,4	1/4" - 28 UNF	3	24 600	14 600	700	10 700
39,45	50,6	M16	40	28,95	1/4" - 28 UNF	4	31 500	18 900	910	11 200
49,2	50,6	M16	40	30,2	1/4" - 28 UNF	4	31 500	18 900	910	11 200
41,5	57,6	M20	50	30,5	1/4" - 28 UNF	4	31 500	19 400	930	11 800
49,2	57,6	M20	50	30,2	1/4" - 28 UNF	4	31 500	19 400	930	11 800
43,5	63,6	M20	50	32	1/4" - 28 UNF	5	33 500	22 100	1 060	12 200
51,6	63,6	M20	50	32,6	1/4" - 28 UNF	5	33 500	22 100	1 060	12 200

							Width across flats	Load carrying capacity			
								W	Bearing		
							Basic load ratings		Fatigue limit load	C <sub>OrG</sub> N	
B <sub>1</sub>	B <sub>3</sub>	K	T	S <sub>1</sub>	Q	d <sub>3</sub> max.	dyn. C <sub>r</sub> N				stat. C <sub>Or</sub> N
31,5	34,05	M16	36	23,5	1/4" - 28 UNF	33	3	12 300	6 300	300	9 600
32	35,95	M16	36	23,5	1/4" - 28 UNF	37,5	3	13 400	7 500	360	10 000
36,3	43,5	M16	40	26,8	1/4" - 28 UNF	44	4	18 700	10 700	510	10 200
39,5	45,2	M16	40	29,5	1/4" - 28 UNF	55	5	24 600	14 600	700	10 700
43,8	50,6	M16	40	32,8	1/4" - 28 UNF	58	5	31 500	18 900	910	11 200
43,8	57,6	M20	50	32,8	1/4" - 28 UNF	63	5	31 500	19 400	930	11 800
44,3	63,6	M20	50	32,8	1/4" - 28 UNF	69	5	33 500	22 100	1 060	12 200



# Take-up housing units

- Plastic housing
- Guide slots on both sides
- Hole for threaded rod
- Radial insert ball bearing with Corrotect coating
- With eccentric locking collar

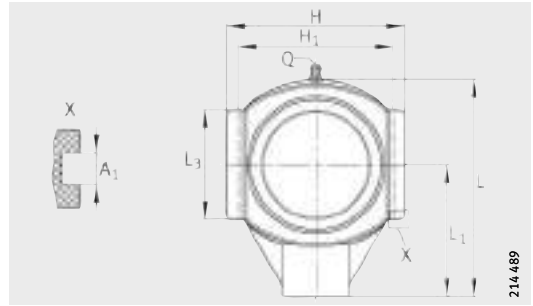

CUGPT

**Dimension table** - Dimensions in mm

Designation			Mass m ≈ kg	Dimensions						
Unit <sup>1)</sup>	Housing	Radial insert ball bearing		d	H	L	L <sub>1</sub>	L <sub>3</sub>	A <sub>1</sub>	A <sub>2</sub>
<b>CUGPT204</b>	GEHPT204	GRAE20-XL-NPP-B-FA107/125	0,4	<b>20</b>	89	99	64	46	12	27,5
<b>CUGPT205</b>	GEHPT205	GRAE25-XL-NPP-B-FA107/125	0,41	<b>25</b>	89	99	64	46	12	27,5
<b>CUGPT206</b>	GEHPT206	GRAE30-XL-NPP-B-FA107/125	0,72	<b>30</b>	102,5	125	76	63,5	12	34
<b>CUGPT207</b>	GEHPT207	GRAE35-XL-NPP-B-FA107/125	0,87	<b>35</b>	102,5	125	76	63,5	12	34
<b>CUGPT208</b>	GEHPT208	GRAE40-XL-NPP-B-FA107/125	1,05	<b>40</b>	114	140	85	80	16	34
<b>CUGPT209<sup>2)</sup></b>	GEHPT209	GRAE45-XL-NPP-B-FA107/125	1,19	<b>45</b>	117	149	90	85	16	40
<b>CUGPT210</b>	GEHPT210	GRAE50-XL-NPP-B-FA107/125	1,28	<b>50</b>	117	149	90	85	16	40

<sup>1)</sup> Available end caps, see page 435.

<sup>2)</sup> Available by agreement.

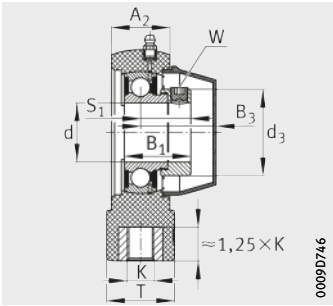

CUGPT

								Width across flats  W	Load carrying capacity			
									Bearing			Housing  C <sub>OrG</sub>  N
									Basic load ratings		Fatigue limit load	
H <sub>1</sub>	B <sub>1</sub>	B <sub>3</sub>	K	T	S <sub>1</sub>	Q	d <sub>3</sub> max.	dyn. C <sub>r</sub> N	stat. C <sub>Or</sub> N	C <sub>ur</sub> N	C <sub>OrG</sub> N	
76	31	34,05	M16	36	23,5	1/4" - 28 UNF	33	3	13 600	6 600	335	9 600
76	31	35,95	M16	36	23,5	1/4" - 28 UNF	37,5	3	14 900	7 800	395	10 000
89	35,8	43,5	M16	40	26,8	1/4" - 28 UNF	44	4	20 700	11 300	570	10 200
89	39	45,2	M16	40	29,5	1/4" - 28 UNF	55	5	27 500	15 300	770	10 700
102	43,8	50,6	M16	40	32,8	1/4" - 28 UNF	58	5	34 500	19 800	1 010	11 200
102	43,8	57,6	M20	50	32,8	1/4" - 28 UNF	63	5	34 500	20 400	1 030	11 800
102	43,8	63,6	M20	50	32,8	1/4" - 28 UNF	69	5	37 500	23 200	1 180	12 200



# Take-up housing units

- Plastic housing
- Guide surfaces on both sides
- Hole for threaded rod
- Radial insert ball bearing in corrosion-resistant VA design
- With grub screw or eccentric locking collar

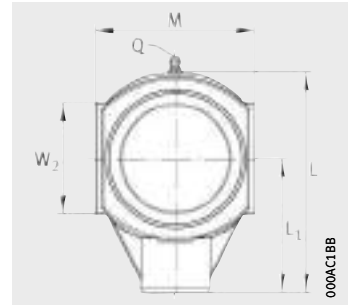

SUBPHE, SUCPHE, SUGPHE

**Dimension table** - Dimensions in mm

Designation			Mass	Dimensions						
Unit <sup>1)</sup>	Housing	Radial insert ball bearing		m ≈ kg	d	M	L	L <sub>1</sub>	W <sub>2</sub>	A <sub>2</sub>
<b>SUBPHE204</b>	GEHPHE204	SUB204	0,32	<b>20</b>	65	99	64	46	27,5	26
<b>SUCPHE204</b>	GEHPHE204	SUC204	0,35	<b>20</b>	65	99	64	46	27,5	31
<b>SUBPHE205</b>	GEHPHE205	SUB205	0,35	<b>25</b>	74	99	64	46	27,5	28
<b>SUCPHE205</b>	GEHPHE205	SUC205	0,39	<b>25</b>	74	99	64	46	27,5	34,1
<b>SUBPHE206</b>	GEHPHE206	SUB206	0,6	<b>30</b>	90	125	76	63,5	34	30,5
<b>SUCPHE206</b>	GEHPHE206	SUC206	0,63	<b>30</b>	90	125	76	63,5	34	38,1
<b>SUBPHE207</b>	GEHPHE207	SUB207	0,69	<b>35</b>	90	125	76	63,5	34	35,45
<b>SUCPHE207</b>	GEHPHE207	SUC207	0,75	<b>35</b>	90	125	76	63,5	34	42,9
<b>SUBPHE208</b>	GEHPHE208	SUB208	0,87	<b>40</b>	100	140	85	80	34	39,45
<b>SUCPHE208</b>	GEHPHE208	SUC208	0,97	<b>40</b>	100	140	85	80	34	49,2
<b>SUBPHE209<sup>2)</sup></b>	GEHPHE209	SUB209	1,07	<b>45</b>	110	149	90	85	40	41,5
<b>SUCPHE209<sup>2)</sup></b>	GEHPHE209	SUC209	1,13	<b>45</b>	110	149	90	85	40	49,2
<b>SUBPHE210<sup>2)</sup></b>	GEHPHE210	SUB210	1,17	<b>50</b>	110	149	90	85	40	43,5
<b>SUCPHE210<sup>2)</sup></b>	GEHPHE210	SUC210	1,28	<b>50</b>	110	149	90	85	40	51,6

**Dimension table** - Dimensions in mm

Designation			Mass	Dimensions						
Unit <sup>1)</sup>	Housing	Radial insert ball bearing		m ≈ kg	d	M	L	L <sub>1</sub>	W <sub>2</sub>	A <sub>2</sub>
<b>SUGPHE204</b>	GEHPHE204	SUG204	0,35	<b>20</b>	65	99	64	46	27,5	31,5
<b>SUGPHE205</b>	GEHPHE205	SUG205	0,38	<b>25</b>	74	99	64	46	27,5	32
<b>SUGPHE206</b>	GEHPHE206	SUG206	0,65	<b>30</b>	90	125	76	63,5	34	36,3
<b>SUGPHE207</b>	GEHPHE207	SUG207	0,79	<b>35</b>	90	125	76	63,5	34	39,5
<b>SUGPHE208</b>	GEHPHE208	SUG208	0,95	<b>40</b>	100	140	85	80	34	43,8
<b>SUGPHE209<sup>2)</sup></b>	GEHPHE209	SUG209	1,16	<b>45</b>	110	149	90	85	40	43,8
<b>SUGPHE210<sup>2)</sup></b>	GEHPHE210	SUG210	1,27	<b>50</b>	110	149	90	85	40	44,3

<sup>1)</sup> Available end caps, see page 435.

<sup>2)</sup> Available by agreement.



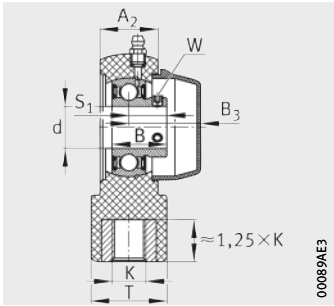

SUBPHE

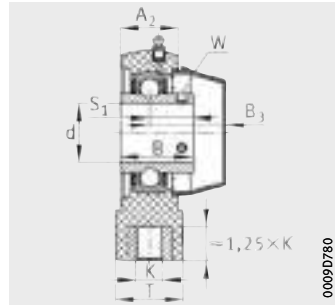

SUCPHE

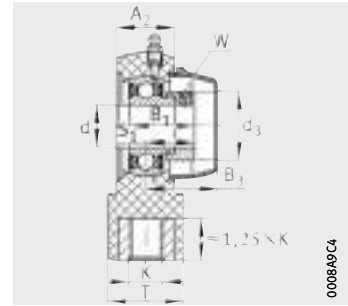

SUGPHE

					Width across flats	Load carrying capacity				
						W	Bearing			Housing
							Basic load ratings		Fatigue limit load	
$B_3$	K	T	$S_1$	Q		dyn. $C_r$ N	stat. $C_{Or}$ N	$C_{ur}$ N		
34,05	M16	36	18	1/4" - 28 UNF	2,5	12 300	6 300	300	9 600	
34,05	M16	36	18,3	1/4" - 28 UNF	2,5	12 300	6 300	300	9 600	
35,95	M16	36	19,5	1/4" - 28 UNF	2,5	13 400	7 500	360	10 000	
35,95	M16	36	19,8	1/4" - 28 UNF	2,5	13 400	7 500	360	10 000	
43,5	M16	40	21	1/4" - 28 UNF	3	18 700	10 700	510	10 200	
43,5	M16	40	22,2	1/4" - 28 UNF	3	18 700	10 700	510	10 200	
45,2	M16	40	25,45	1/4" - 28 UNF	3	24 600	14 600	700	10 700	
45,2	M16	40	25,4	1/4" - 28 UNF	3	24 600	14 600	700	10 700	
50,6	M16	40	28,95	1/4" - 28 UNF	4	31 500	18 900	910	11 200	
50,6	M16	40	30,2	1/4" - 28 UNF	4	31 500	18 900	910	11 200	
57,6	M20	50	30,5	1/4" - 28 UNF	4	31 500	19 400	930	11 800	
57,6	M20	50	30,2	1/4" - 28 UNF	4	31 500	19 400	930	11 800	
63,6	M20	50	32	1/4" - 28 UNF	5	33 500	22 100	1 060	12 200	
63,6	M20	50	32,6	1/4" - 28 UNF	5	33 500	22 100	1 060	12 200	

						Width across flats	Load carrying capacity				
							W	Bearing			Housing
								Basic load ratings		Fatigue limit load	
$B_3$	K	T	$S_1$	Q	$d_3$ max.		dyn. $C_r$ N	stat. $C_{Or}$ N	$C_{ur}$ N		
34,05	M16	36	23,5	1/4" - 28 UNF	33	3	12 300	6 300	300	9 600	
35,95	M16	36	23,5	1/4" - 28 UNF	37,5	3	13 400	7 500	360	10 000	
43,5	M16	40	26,8	1/4" - 28 UNF	44	4	18 700	10 700	510	10 200	
45,2	M16	40	29,5	1/4" - 28 UNF	55	5	24 600	14 600	700	10 700	
50,6	M16	40	32,8	1/4" - 28 UNF	58	5	31 500	18 900	910	11 200	
57,6	M20	50	32,8	1/4" - 28 UNF	63	5	31 500	19 400	930	11 800	
63,6	M20	50	32,8	1/4" - 28 UNF	69	5	33 500	22 100	1 060	12 200	



# Take-up housing units

- Plastic housing
- Guide surfaces on both sides
- Hole for threaded rod
- Radial insert ball bearing with Corrotect coating
- With eccentric locking collar

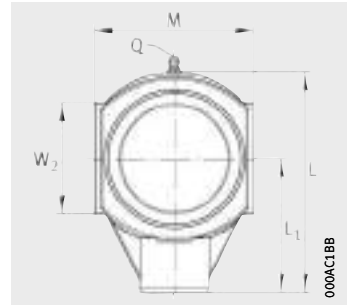

CUGPHE

**Dimension table** - Dimensions in mm

Designation			Mass  m ≈ kg	Dimensions					
Unit <sup>1)</sup>	Housing	Radial insert ball bearing		d	M	L	L <sub>1</sub>	W <sub>2</sub>	A <sub>2</sub>
<b>CUGPHE204</b>	GEHPHE204	GRAE20-XL-NPP-B-FA107/125	0,37	<b>20</b>	65	99	64	46	27,5
<b>CUGPHE205</b>	GEHPHE205	GRAE25-XL-NPP-B-FA107/125	0,39	<b>25</b>	74	99	64	46	27,5
<b>CUGPHE206</b>	GEHPHE206	GRAE30-XL-NPP-B-FA107/125	0,69	<b>30</b>	90	125	76	63,5	34
<b>CUGPHE207</b>	GEHPHE207	GRAE35-XL-NPP-B-FA107/125	0,84	<b>35</b>	90	125	76	63,5	34
<b>CUGPHE208</b>	GEHPHE208	GRAE40-XL-NPP-B-FA107/125	1,02	<b>40</b>	100	140	85	80	34
<b>CUGPHE209<sup>2)</sup></b>	GEHPHE209	GRAE45-XL-NPP-B-FA107/125	1,16	<b>45</b>	110	149	90	85	40
<b>CUGPHE210<sup>2)</sup></b>	GEHPHE210	GRAE50-XL-NPP-B-FA107/125	1,24	<b>50</b>	110	149	90	85	40

<sup>1)</sup> Available end caps, see page 435.

<sup>2)</sup> Available by agreement.

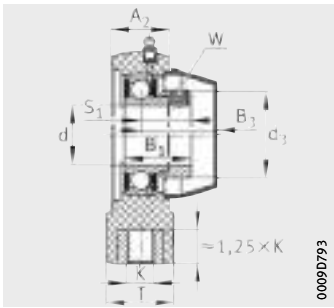

CUGPHE

							Width across flats  W	Load carrying capacity			
								Bearing			Housing  C <sub>0rG</sub>  N
								Basic load ratings		Fatigue limit load	
B <sub>1</sub>	B <sub>3</sub>	K	T	S <sub>1</sub>	Q	d <sub>3</sub> max.	dyn. C <sub>r</sub> N	stat. C <sub>0r</sub> N	C <sub>ur</sub> N	C <sub>0rG</sub> N	
31	34,05	M16	36	23,5	1/4" - 28 UNF	33	3	13 600	6 600	335	9 600
31	35,95	M16	36	23,5	1/4" - 28 UNF	37,5	3	14 900	7 800	395	10 000
35,8	43,5	M16	40	26,8	1/4" - 28 UNF	44	4	20 700	11 300	570	10 200
39	45,2	M16	40	29,5	1/4" - 28 UNF	55	5	27 500	15 300	770	10 700
43,8	50,6	M16	40	32,8	1/4" - 28 UNF	58	5	34 500	19 800	1 010	11 200
43,8	57,6	M20	50	32,8	1/4" - 28 UNF	63	5	34 500	20 400	1 030	11 800
43,8	63,6	M20	50	32,8	1/4" - 28 UNF	69	5	37 500	23 200	1 180	12 200







## **Black Series**

Radial insert ball bearings and housing units



# FAG Black Series, radial insert ball bearings and housing units

## Radial insert ball bearings ..... 470

### Black Series

The new radial insert ball bearing and housing units FAG Black Series from Schaeffler give easy mounting, smooth running and high reliability and thus allow particularly economical bearing arrangements.

FAG radial insert ball bearings with a spherical outer ring are based on single row deep groove ball bearings 62 and are designed in accordance with JIS B 1558. The outer and inner rings as well as the flinger shields of the radial insert ball bearings are provided with the Durotect BS coating in order to offer basic protection against corrosion. The Black Series radial insert ball bearings are available with two location methods and one type of seal. They can be relubricated and are particularly easy to install.

---

## Housing units ..... 488

### Black Series

The dimensions of the FAG housings, made from flake graphite cast iron and with a primer paint coating, conform to JIS B 1559. These single piece cast housings can support moderate to high radial and axial loads. The radial insert ball bearings have basic protection against corrosion due to the Durotect BS coating.

The bearing units are particularly suitable for applications with moderate to high loads.

Typical areas of application for these bearings include the agricultural, construction and mining sector, power transmission and conveying equipment as well as in pumps, textile, paper and woodworking machinery, in machinery for the timber, filling and packaging industries and in the steel industry.

Housing units in accordance with JIS B 1557 comprise FAG flake graphite cast iron housings with a concave bore in which FAG radial insert ball bearings are fitted. These units are matched to each other and are available as plummer block housing units, flanged housing units and take-up housing units.

Radial insert ball bearings with a spherical outer ring, when fitted in housings with a concave bore, can compensate for static misalignment of the shaft.

Housing units are supplied with a loose packed lubrication nipple and integrated end cap for the lubrication nipple as well as an Allen key.



UC



UK

0008528

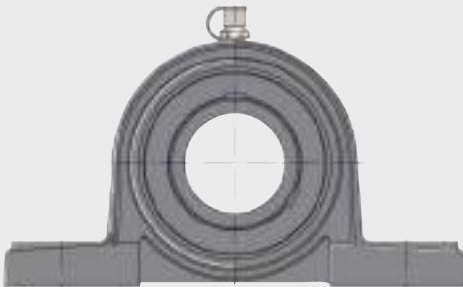

P

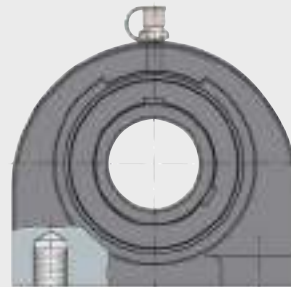

PA



FL

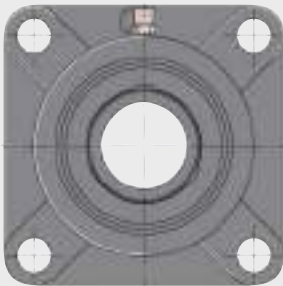

F

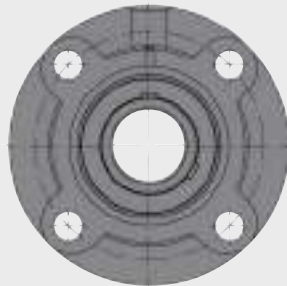

FC

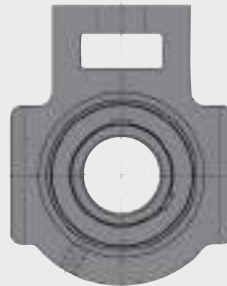

T



FA



0008531

**FAG**



**Radial insert ball bearings**



# Radial insert ball bearings

	Page
<b>Matrix</b>	
Features of radial insert ball bearings, comparison of series .....	472
<b>Product overview</b>	
Radial insert ball bearings .....	474
<b>Features</b>	
Anti-corrosion protection .....	475
Location on shaft.....	475
Sealing.....	476
Operating temperature .....	476
<b>Design and safety guidelines</b>	
Compensation of static misalignments.....	477
Minimum radial load .....	477
Speed limits for radial insert ball bearings .....	478
Shaft tolerances for radial insert ball bearings .....	479
<b>Accuracy</b>	
Standard tolerances of radial insert ball bearings.....	479
Radial internal clearance of radial insert ball bearings.....	480
<b>Dimension tables</b>	
Radial insert ball bearings with grub screws in inner ring, spherical outer ring .....	482
Radial insert ball bearings with adapter sleeve, spherical outer ring .....	486



**Features of  
radial insert ball bearings,  
comparison of series**

Series	Shaft diameter				Location
	mm		inch		
	from	to	from	to	
<b>UC</b>	12	90	1/2	3 1/2	Grub screw
<b>UK</b>	20	80	–	–	Adapter sleeve to JIS B 1552

- 1) Attention!  
Recommended operating temperature of bearing series.  
If temperatures exceed +100 °C, relubrication must be carried out regularly.
- 2) Temperature peaks of up to +120 °C possible for short periods.

Seal	Compensation of misalignment	Internal clearance	Cage	Grease	Relubrication facility	Temperature <sup>1)</sup> °C		Comments	Dimension table
						from	up to		Page
RSR	yes	C3	PA66	GA13	yes	-20	+100 <sup>2)</sup>	Corrosion-resistant	482
RSR	yes	C4	PA66	GA13	yes	-20	+100 <sup>2)</sup>	Corrosion-resistant	486



# Product overview Radial insert ball bearings

**With grub screws  
in inner ring**  
Spherical outer ring



**With adapter sleeve**  
Spherical outer ring



# Radial insert ball bearings

**Features** These radial insert ball bearings are based on single row deep groove ball bearings 62 and comprise a solid section outer ring and an inner ring extended on both sides.

The bearings have plastic cages and are sealed on both sides by single piece seals RSR with a vulcanised seal lip and an outer flinger shield.

The honed raceways of the bearing rings, in conjunction with the high ball grade, ensure quiet running and a reduced frictional torque.

The outer ring has a spherical outside surface. In combination with a housing matched to the design, bearings with a spherical outer ring can compensate static misalignments of the shaft, see page 477.

The radial insert ball bearings are pregreased and can be relubricated by means of two lubrication holes in the outer ring.

**Inch size designs** The radial insert ball bearings are also available with inch size bore dimensions, see dimension table.

**Anti-corrosion protection** The inner and outer rings as well as the flinger shields of the radial insert ball bearings are provided with the black Durotect BS coating in order to offer basic protection against corrosion.

Adapter sleeves have a Durotect BS or phosphate coating.

**Location on shaft** Radial insert ball bearings are particularly easy to fit and are preferentially suitable for drawn shafts with the tolerances h6  $\oplus$  to h9  $\oplus$ .

In the radial insert ball bearings UC, the inner ring is located on the shaft by means of two grub screws offset by 120°, *Figure 1*, page 476. They are suitable for bearing arrangements with a constant direction of rotation or, under low speed and load, for an alternating direction of rotation.

The grub screws are self-retaining and have a fine pitch thread with cup point for secure location of the bearings. In order to allow better differentiation, the metric grub screws have a Durotect BS coating while the inch size grub screws are zinc plated.

In the case of radial insert ball bearings UK, the inner ring is located on the shaft by means of a concentric adapter sleeve in accordance with JIS B 1552, *Figure 2*, page 476. The roughness of the adapter sleeve on the inside and outside is Ra 2,5. They are suitable for bearing arrangements with an alternating direction of rotation, even under high speed and load.



# Radial insert ball bearings

UC

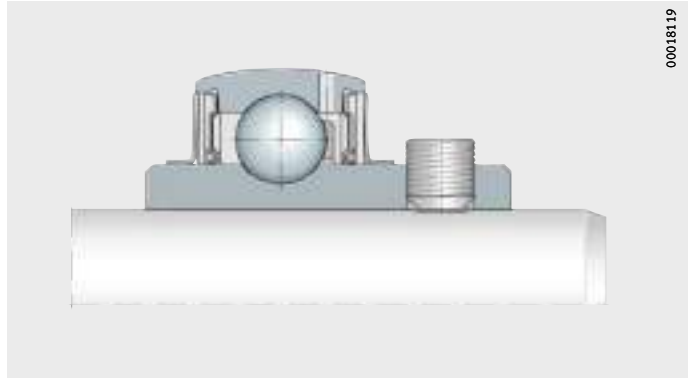

00018119

*Figure 1*  
Location by grub screws  
in the inner ring

UK

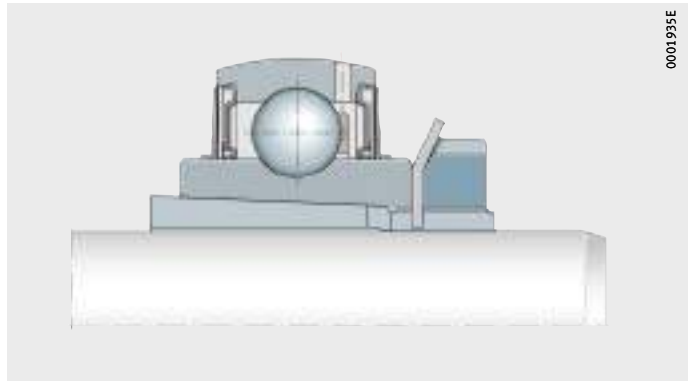

0001935E

*Figure 2*  
Location by adapter sleeve

## Tightening torques

Tightening torques for metric and inch size grub screws, see table, page 500.  
Tightening torques for locknuts, see table, page 501.

## Sealing

FAG Black Series radial insert ball bearings are supplied with seals RSR, see table.

## Seal types

Seal RSR	
	<p>0001811A</p> <p>Single piece, zinc plated sheet steel washer with vulcanised and radially preloaded seal lip made from NBR and additional flinger shield</p>

## Operating temperature

The insert bearings are suitable for operating temperatures of  $-20\text{ }^{\circ}\text{C}$  to  $+100\text{ }^{\circ}\text{C}$ . Temperature peaks of up to  $+120\text{ }^{\circ}\text{C}$  are possible for short periods.



In the case of temperatures over  $\vartheta = +100\text{ }^{\circ}\text{C}$ , relubrication must be carried out regularly.

## Design and safety guidelines

### Compensation of static misalignments

Bearings with a spherical outer ring, fitted in housings with a concave bore, can compensate for static misalignment of the shaft, *Figure 3*:

For units with a lubrication groove in the housing and a lubrication hole in the radial insert ball bearing, the following applies:

- Up to  $\pm 2,5^\circ$ , the units can be relubricated.
- Between  $\pm 2,5^\circ$  and  $\pm 5^\circ$ , the facility for relubrication is dependent on the specific unit. Please contact us in this case.
- Above  $\pm 5^\circ$ , relubrication is no longer possible.



The units must not be used to support swivelling or tumbling motion.



*Figure 3*  
Compensation of static shaft misalignment

### Minimum radial load

In order to ensure slippage-free operation, the bearings must be subjected to a minimum radial load. This applies particularly in the case of high speeds and high accelerations. In continuous operation, a minimum radial load of the order of  $P \cong 0,01 \cdot C_r$  is necessary for ball bearings with cage.



# Radial insert ball bearings

## Speed limits for radial insert ball bearings

The speed limits are dependent on the load, the clearance between the bearing bore and shaft and the friction of the seals in the case of bearings with contact seals.

Guide values for the permissible speeds can be derived from the diagram, *Figure 4*.

In the case of load ratios  $C_r/P > 13$ , the speeds can be increased. At  $C_r/P < 5$ , location by means of a fit is recommended, see section Conditions of rotation, chapter Technical principles, Catalogue HR 1, Rolling Bearings. For both types of applications, please contact us.

Example of permissible speed calculation

Given:

- Shaft tolerance h6 ©
- Radial insert ball bearing UC206
- Basic dynamic load rating  $C_r$  20 700 N
- Load P 1 300 N
- Sealing Seals RSR.

Required:

- Load ratio  $C_r/P = 20\,700\text{ N}/1\,300\text{ N}$   $C_r/P > 13$
- Permissible speed  $n \approx 4\,300\text{ min}^{-1}$ , *Figure 4*.

n = permissible speed  
 h5, h6, h9 = shaft tolerance  
 (this is subject to the envelope requirement ©)  
 $C_r/P$  = load ratio

① Ball set  
 (bearings of sizes 201, 202, 203 and 204 all have the ball set 204)

*Figure 4*  
 Permissible speeds for radial insert ball bearings with seals RSR

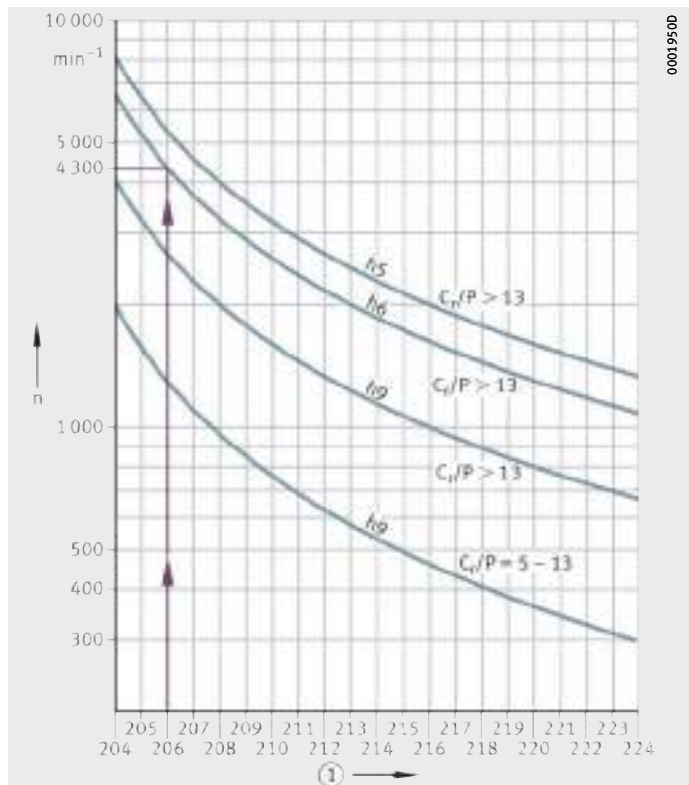



### Shaft tolerances for radial insert ball bearings

The permissible shaft tolerance is dependent on the speed and load. Tolerances h6  $\oplus$  to h9  $\oplus$  are recommended.

Conventional drawn shafts will suffice for most applications.

### Accuracy Standard tolerances of radial insert ball bearings

The outside diameter tolerances of the bearings conform to the tolerances in accordance with JIS B 1558. The inner ring bore has a plus tolerance to allow easier mounting of the bearing, see tables.

#### Inner ring tolerances

Nominal bearing bore diameter d mm		Variation <sup>1)</sup> $\Delta_{dmp}$ $\mu\text{m}$		Width deviation $\Delta_{Bs}$ $\mu\text{m}$	
over	incl.	min.	max.	min.	max.
10	18	0	+15	-120	0
18	31,75	0	+18	-120	0
31,75	50,8	0	+21	-120	0
50,8	80,962	0	+24	-150	0
80,962	120	0	+28	-200	0

<sup>1)</sup> This corresponds to the arithmetic mean value derived from the largest and smallest diameters (measured using a two-point measuring device).

#### Outer ring tolerances

Nominal outside diameter $D_{sp}$ mm		Variation <sup>1)</sup> $\Delta_{Dm}$ $\mu\text{m}$	
over	incl.	min.	max.
30	50	-11	0
50	80	-13	0
80	120	-15	0
120	150	-18	0
150	180	-25	0
180	250	-30	0

<sup>1)</sup> In the case of sealed bearings, the largest and smallest values of the outside diameter can deviate from the mean value by approx. 0,03 mm.



# Radial insert ball bearings

## Radial internal clearance of radial insert ball bearings

The radial internal clearance in accordance with JIS B 1520 is C3 for radial insert ball bearings UC and C4 for radial insert ball bearings UK. It is thus larger than in the case of normal deep groove ball bearings, see table.

The larger internal clearance allows better support of misalignments and shaft deflection.

### Radial internal clearance

Bore		Ball set	Outside diameter D mm	Radial internal clearance			
d mm	inch			C3 μm		C4 μm	
				min.	max.	min.	max.
12	–	204	47	13	28	20	36
12,7	1/2						
14,288	9/16						
15	–						
15,875	5/8						
17	–						
17,462	11/16						
19,05	3/4						
20	–						
20,638	13/16	205	52	13	28	23	41
22,225	7/8						
23,812	15/16						
25	–						
25,4	1						
26,988	1 1/16						
28,575	1 1/8	206	62	13	28	23	41
30	–						
30,162	1 3/16						
31,75	1 1/4						
31,75	1 1/4						
33,338	1 5/16						
34,925	1 3/8	207	72	15	33	28	46
35	–						
36,512	1 7/16						
38,1	1 1/2						
39,688	1 9/16						
40	–						
41,275	1 5/8	209	85	18	36	30	51
42,862	1 11/16						
44,45	1 3/4						
45	–						
46,038	1 13/16	210	90	18	36	30	51
47,625	1 7/8						
49,212	1 15/16						
50	–						
50,8	2						

Radial internal clearance  
(continued)

Bore		Ball set	Outside diameter D mm	Radial internal clearance			
d mm	inch			C3 μm		C4 μm	
				min.	max.	min.	max.
50,8	2	211	100	23	43	38	61
52,388	2 <sup>1</sup> / <sub>16</sub>						
53,975	2 <sup>1</sup> / <sub>8</sub>						
55	–						
55,562	2 <sup>3</sup> / <sub>16</sub>						
57,15	2 <sup>1</sup> / <sub>4</sub>	212	110	23	43	38	61
58,738	2 <sup>5</sup> / <sub>16</sub>						
60	–						
60,325	2 <sup>3</sup> / <sub>8</sub>						
61,912	2 <sup>7</sup> / <sub>16</sub>						
63,5	2 <sup>1</sup> / <sub>2</sub>	213	120	23	43	38	61
65	–						
65,09	2 <sup>9</sup> / <sub>16</sub>						
66,675	2 <sup>5</sup> / <sub>8</sub>	214	125	23	43	38	61
68,262	2 <sup>11</sup> / <sub>16</sub>						
69,85	2 <sup>3</sup> / <sub>4</sub>						
70	–						
71,438	2 <sup>13</sup> / <sub>16</sub>						
73,025	2 <sup>7</sup> / <sub>8</sub>	215	130	25	51	46	71
74,612	2 <sup>15</sup> / <sub>16</sub>						
75	–						
76,2	3						
77,787	3 <sup>1</sup> / <sub>16</sub>						
79,375	3 <sup>1</sup> / <sub>8</sub>	216	140	25	51	46	71
80	–						
80,962	3 <sup>3</sup> / <sub>16</sub>						
82,55	3 <sup>1</sup> / <sub>4</sub>						
84,137	3 <sup>5</sup> / <sub>16</sub>						
85	–	217	150	25	51	46	71
87,312	3 <sup>7</sup> / <sub>16</sub>						
88,9	3 <sup>1</sup> / <sub>2</sub>						
90	–	218	160	30	58	53	84
93,662	3 <sup>11</sup> / <sub>16</sub>						
95	–	219	170	30	58	53	84
100	–						
100,012	3 <sup>15</sup> / <sub>16</sub>	220	180	30	58	53	84
101,6	4						



# Radial insert ball bearings with grub screws in inner ring

Spherical outer ring

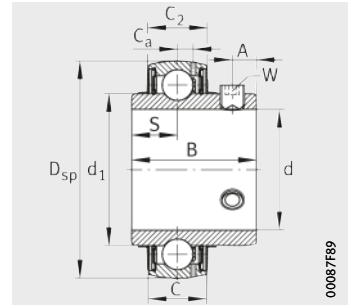

UC

**Dimension table** - Dimensions in mm and inch

Designation	Mass m ≈ kg	Dimensions						
		d		D <sub>sp</sub>	C	C <sub>2</sub>	B	S
		mm	inch					
UC201	0,2	12	–	47	17	16,8	31	12,7
UC201-08	0,2	12,7	1/2	47	17	16,8	31	12,7
UC202-09	0,19	14,288	9/16	47	17	16,8	31	12,7
UC202	0,18	15	–	47	17	16,8	31	12,7
UC202-10	0,18	15,875	5/8	47	17	16,8	31	12,7
UC203	0,17	17	–	47	17	16,8	31	12,7
UC203-11	0,17	17,463	11/16	47	17	16,8	31	12,7
UC204-12	0,16	19,05	3/4	47	17	16,8	31	12,7
UC204	0,15	20	–	47	17	16,8	31	12,7
UC205-13	0,24	20,638	13/16	52	17	17,6	34,1	14,3
UC205-14	0,22	22,225	7/8	52	17	17,6	34,1	14,3
UC205-15	0,21	23,813	15/16	52	17	17,6	34,1	14,3
UC205	0,2	25	–	52	17	17,6	34,1	14,3
UC205-16	0,19	25,4	1	52	17	17,6	34,1	14,3
UC206-17	0,35	26,988	11/16	62	19	19,6	38,1	15,9
UC206-18	0,33	28,575	11/8	62	19	19,6	38,1	15,9
UC206	0,31	30	–	62	19	19,6	38,1	15,9
UC206-19	0,31	30,163	13/16	62	19	19,6	38,1	15,9
UC206-20	0,29	31,75	11/4	62	19	19,6	38,1	15,9
UC207-20	0,52	31,75	11/4	72	20	20,6	42,9	17,5
UC207-21	0,5	33,338	15/16	72	20	20,6	42,9	17,5
UC207-22	0,47	34,925	13/8	72	20	20,6	42,9	17,5
UC207	0,47	35	–	72	20	20,6	42,9	17,5
UC207-23	0,44	36,513	17/16	72	20	20,6	42,9	17,5
UC208-24	0,66	38,1	11/2	80	21	21,6	49,2	19
UC208-25	0,63	39,688	19/16	80	21	21,6	49,2	19
UC208	0,62	40	–	80	21	21,6	49,2	19
UC209-26	0,79	41,275	15/8	85	22	22,6	49,2	19
UC209-27	0,75	42,863	111/16	85	22	22,6	49,2	19
UC209-28	0,71	44,45	13/4	85	22	22,6	49,2	19
UC209	0,69	45	–	85	22	22,6	49,2	19
UC210-29	0,92	46,038	113/16	90	24	24,6	51,6	19
UC210-30	0,87	47,625	17/8	90	24	24,6	51,6	19
UC210-31	0,82	49,213	115/16	90	24	24,6	51,6	19
UC210	0,8	50	–	90	24	24,6	51,6	19
UC210-32	0,77	50,8	2	90	24	24,6	51,6	19

			Width across flats		Basic load ratings		Fatigue limit load	Factor
d <sub>1</sub>	C <sub>a</sub>	A	W		dyn. C <sub>r</sub>	stat. C <sub>0r</sub>	C <sub>ur</sub>	f <sub>0</sub>
			mm	inch	N	N		
27,56	4,2	5	3	–	13 600	6 600	335	13,1
27,56	4,2	5	–	1/8	13 600	6 600	335	13,1
27,56	4,2	5	–	1/8	13 600	6 600	335	13,1
27,56	4,2	5	3	–	13 600	6 600	335	13,1
27,56	4,2	5	–	1/8	13 600	6 600	335	13,1
27,56	4,2	5	3	–	13 600	6 600	335	13,1
27,56	4,2	5	–	1/8	13 600	6 600	335	13,1
27,56	4,2	5	–	1/8	13 600	6 600	335	13,1
27,56	4,2	5	3	–	13 600	6 600	335	13,1
33,83	4,2	5	–	1/8	14 900	7 800	395	13,8
33,83	4,2	5	–	1/8	14 900	7 800	395	13,8
33,83	4,2	5	–	1/8	14 900	7 800	395	13,8
33,83	4,2	5	3	–	14 900	7 800	395	13,8
33,83	4,2	5	–	1/8	14 900	7 800	395	13,8
40,2	5	5	–	1/8	20 700	11 300	570	13,8
40,2	5	5	–	1/8	20 700	11 300	570	13,8
40,2	5	5	3	–	20 700	11 300	570	13,8
40,2	5	5	–	1/8	20 700	11 300	570	13,8
40,2	5	5	–	1/8	20 700	11 300	570	13,8
46,84	5,7	7	–	5/32	27 500	15 300	770	13,8
46,84	5,7	7	–	5/32	27 500	15 300	770	13,8
46,84	5,7	7	–	5/32	27 500	15 300	770	13,8
46,84	5,7	7	4	–	27 500	15 300	770	13,8
46,84	5,7	7	–	5/32	27 500	15 300	770	13,8
52,27	6,2	8	–	5/32	34 500	19 800	1 010	14
52,27	6,2	8	–	5/32	34 500	19 800	1 010	14
52,27	6,2	8	4	–	34 500	19 800	1 010	14
57,91	6,3	8	–	5/32	34 500	20 400	1 030	14,3
57,91	6,3	8	–	5/32	34 500	20 400	1 030	14,3
57,91	6,3	8	–	5/32	34 500	20 400	1 030	14,3
57,91	6,3	8	4	–	34 500	20 400	1 030	14,3
62,84	6,5	10	–	3/16	37 500	23 200	1 180	14,3
62,84	6,5	10	–	3/16	37 500	23 200	1 180	14,3
62,84	6,5	10	–	3/16	37 500	23 200	1 180	14,3
62,84	6,5	10	5	–	37 500	23 200	1 180	14,3
62,84	6,5	10	–	3/16	37 500	23 200	1 180	14,3



# Radial insert ball bearings with grub screws in inner ring

Spherical outer ring

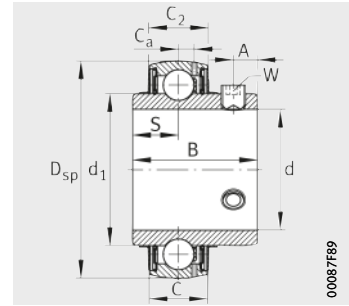

UC

**Dimension table** (continued) · Dimensions in mm and inch

Designation	Mass m ≈ kg	Dimensions						
		d		D <sub>sp</sub>	C	C <sub>2</sub>	B	S
		mm	inch					
UC211-32	1,22	50,8	2	100	25	25,6	55,6	22,2
UC211-33	1,17	52,388	2 <sup>1</sup> / <sub>16</sub>	100	25	25,6	55,6	22,2
UC211-34	1,11	53,975	2 <sup>1</sup> / <sub>8</sub>	100	25	25,6	55,6	22,2
UC211	1,07	55	–	100	25	25,6	55,6	22,2
UC211-35	1,05	55,563	2 <sup>3</sup> / <sub>16</sub>	100	25	25,6	55,6	22,2
UC212-36	1,62	57,15	2 <sup>1</sup> / <sub>4</sub>	110	27	27,6	65,1	25,4
UC212-37	1,55	58,738	2 <sup>5</sup> / <sub>16</sub>	110	27	27,6	65,1	25,4
UC212	1,49	60	–	110	27	27,6	65,1	25,4
UC212-38	1,48	60,325	2 <sup>3</sup> / <sub>8</sub>	110	27	27,6	65,1	25,4
UC212-39	1,4	61,913	2 <sup>7</sup> / <sub>16</sub>	110	27	27,6	65,1	25,4
UC213-40	1,79	63,5	2 <sup>1</sup> / <sub>2</sub>	120	28	29,4	65,1	25,4
UC213	1,72	65	–	120	28	29,4	65,1	25,4
UC213-41	1,71	65,088	2 <sup>9</sup> / <sub>16</sub>	120	28	29,4	65,1	25,4
UC214-42	2,17	66,675	2 <sup>5</sup> / <sub>8</sub>	125	30	31,4	74,6	30,2
UC214-43	2,07	68,263	2 <sup>11</sup> / <sub>16</sub>	125	30	31,4	74,6	30,2
UC214-44	1,97	69,85	2 <sup>3</sup> / <sub>4</sub>	125	30	31,4	74,6	30,2
UC214	1,96	70	–	125	30	31,4	74,6	30,2
UC215-45	2,39	71,438	2 <sup>13</sup> / <sub>16</sub>	130	32	33,4	77,8	33,3
UC215-46	2,28	73,025	2 <sup>7</sup> / <sub>8</sub>	130	32	33,4	77,8	33,3
UC215-47	2,17	74,613	2 <sup>15</sup> / <sub>16</sub>	130	32	33,4	77,8	33,3
UC215	2,14	75	–	130	32	33,4	77,8	33,3
UC215-48	2,06	76,2	3	130	32	33,4	77,8	33,3
UC216-49	2,88	77,788	3 <sup>1</sup> / <sub>16</sub>	140	33	34,4	82,6	33,3
UC216-50	2,76	79,375	3 <sup>1</sup> / <sub>8</sub>	140	33	34,4	82,6	33,3
UC216	2,71	80	–	140	33	34,4	82,6	33,3
UC216-51	2,63	80,963	3 <sup>3</sup> / <sub>16</sub>	140	33	34,4	82,6	33,3
UC217-52	3,62	82,55	3 <sup>1</sup> / <sub>4</sub>	150	35	36,4	85,7	34,1
UC217-53	3,48	84,138	3 <sup>5</sup> / <sub>16</sub>	150	35	36,4	85,7	34,1
UC217	3,41	85	–	150	35	36,4	85,7	34,1
UC217-55	3,2	87,313	3 <sup>7</sup> / <sub>16</sub>	150	35	36,4	85,7	34,1
UC218-56	4,2	88,9	3 <sup>1</sup> / <sub>2</sub>	160	38	39,4	96	39,7
UC218	4,08	90	–	160	38	39,4	96	39,7

			Width across flats		Basic load ratings		Fatigue limit load	Factor
d <sub>1</sub>	C <sub>a</sub>	A	W		dyn. C <sub>r</sub>	stat. C <sub>0r</sub>	C <sub>ur</sub>	f <sub>0</sub>
			mm	inch	N	N		
69,77	7	10	–	3/16	46 000	29 000	1 480	14,3
69,77	7	10	–	3/16	46 000	29 000	1 480	14,3
69,77	7	10	–	3/16	46 000	29 000	1 480	14,3
69,77	7	10	5	–	46 000	29 000	1 480	14,3
69,77	7	10	–	3/16	46 000	29 000	1 480	14,3
76,48	7,4	10	–	3/16	56 000	36 000	1 820	14,3
76,48	7,4	10	–	3/16	56 000	36 000	1 820	14,3
76,48	7,4	10	5	–	56 000	36 000	1 820	14,3
76,48	7,4	10	–	3/16	56 000	36 000	1 820	14,3
76,48	7,4	10	–	3/16	56 000	36 000	1 820	14,3
80,85	8,2	12	–	1/4	61 000	40 000	2 030	14,3
80,85	8,2	12	6	–	61 000	40 000	2 030	14,3
80,85	8,2	12	–	1/4	61 000	40 000	2 030	14,3
85,2	8,5	12	–	1/4	66 000	44 000	2 230	14,4
85,2	8,5	12	–	1/4	66 000	44 000	2 230	14,4
85,2	8,5	12	–	1/4	66 000	44 000	2 230	14,4
85,2	8,5	12	6	–	66 000	44 000	2 230	14,4
90	8,5	12	–	1/4	66 000	44 500	2 240	14,7
90	8,5	12	–	1/4	66 000	44 500	2 240	14,7
90	8,5	12	–	1/4	66 000	44 500	2 240	14,7
90	8,5	12	6	–	66 000	44 500	2 240	14,7
90	8,5	12	–	1/4	66 000	44 500	2 240	14,7
97	9,3	14	–	1/4	76 000	54 000	2 600	14,6
97	9,3	14	–	1/4	76 000	54 000	2 600	14,6
97	9,3	14	6	–	76 000	54 000	2 600	14,6
97	9,3	14	–	1/4	76 000	54 000	2 600	14,6
104,09	10	14	–	1/4	88 000	64 000	2 950	14,7
104,09	10	14	–	1/4	88 000	64 000	2 950	14,7
104,09	10	14	6	–	88 000	64 000	2 950	14,7
104,09	10	14	–	1/4	88 000	64 000	2 950	14,7
109,4	11	15	–	1/4	102 000	72 000	3 250	14,5
109,4	11	15	6	–	102 000	72 000	3 250	14,5



# Radial insert ball bearings with adapter sleeve

Spherical outer ring

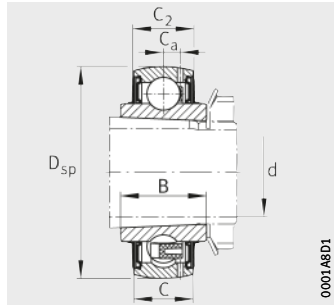

UK

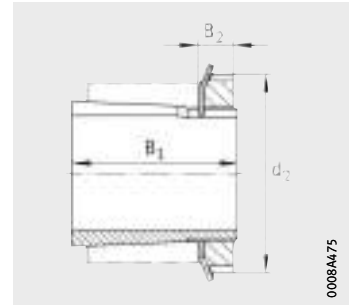

Complete adapter sleeve<sup>1)</sup>

**Dimension table** - Dimensions in mm

Designation	Mass m ≈ kg	Dimensions						Basic load ratings		Fatigue limit load C <sub>ur</sub> N	Factor f <sub>0</sub>
		d	D <sub>sp</sub>	C	C <sub>2</sub>	B	C <sub>a</sub>	dyn. C <sub>r</sub> N	stat. C <sub>0r</sub> N		
UK205	0,25	20	52	17	17,6	23	4,2	14 900	7 800	395	13,8
UK206	0,37	25	62	19	19,6	26	5	20 700	11 300	570	13,8
UK207	0,54	30	72	20	20,6	29	5,7	27 500	15 300	770	13,8
UK208	0,7	35	80	21	21,6	31	6,2	34 500	19 800	1 010	14
UK209	0,83	40	85	22	22,6	32	6,3	34 500	20 400	1 030	14,3
UK210	0,98	45	90	24	24,6	34	6,5	37 500	23 200	1 180	14,3
UK211	1,24	50	100	25	25,6	36	7	46 000	29 000	1 480	14,3
UK212	1,58	55	110	27	27,6	40	7,4	56 000	36 000	1 820	14,3
UK213	1,88	60	120	28	29,4	41	8,2	61 000	40 000	2 030	14,3
UK215	2,62	65	130	32	33,4	44,5	8,5	66 000	44 500	2 240	14,7
UK216	3,23	70	140	33	34,4	46	9,3	76 000	54 000	2 600	14,6
UK217	3,9	75	150	35	36,4	48	10	88 000	64 000	2 950	14,7
UK218	4,62	80	160	38	39,4	51	11	102 000	72 000	3 250	14,5

<sup>1)</sup> Radial insert ball bearings UK are supplied with an adapter sleeve H..X.

Designation					Mass m ≈ kg	Dimensions		
Complete adapter sleeve	Sleeve	Locknut	Tab washer	Matching bearing		B <sub>1</sub>	B <sub>2</sub>	d <sub>2</sub> max.
H2305X	A2305X	AN05	AW05X	UK205	0,1	35	8	38
H2306X	A2306X	AN06	AW06X	UK206	0,13	38	8	45
H2307X	A2307X	AN07	AW07X	UK207	0,18	43	9	52
H2308X	A2308X	AN08	AW08X	UK208	0,23	46	10	58
H2309X	A2309X	AN09	AW09X	UK209	0,31	50	11	65
H2310X	A2310X	AN10	AW10X	UK210	0,38	55	12	70
H2311X	A2311X	AN11	AW11X	UK211	0,45	59	12	75
H2312X	A2312X	AN12	AW12X	UK212	0,5	62	13	80
H2313X	A2313X	AN13	AW13X	UK213	0,58	65	14	85
H2315X	A2315X	AN15	AW15X	UK215	1,1	73	15	98
H2316X	A2316X	AN16	AW16X	UK216	1,33	78	17	105
H2317X	A2317X	AN17	AW17X	UK217	1,51	82	18	110
H2318X	A2318X	AN18	AW18X	UK218	1,77	86	18	120





**FAG**





**Housing units**

# Housing units

	Page
<b>Matrix</b>	Possible combinations of radial insert ball bearings and housings..... 490
<b>Product overview</b>	Housing units..... 492
<b>Features</b>	Housing units with flake graphite cast iron housing..... 494
	Operating temperature ..... 496
<b>Design and safety guidelines</b>	Compensation of static misalignments..... 497
	Load carrying capacity of housings ..... 497
	Load carrying capacity and speed limits of radial insert ball bearings ..... 497
	Design of adjacent construction..... 497
	Mounting and dismounting..... 498
<b>Accuracy</b>	Dimensional tolerances ..... 501
<b>Dimension tables</b>	Plummer block housing units, flake graphite cast iron housing with long base
	with grub screws in inner ring..... 502
	with adapter sleeve..... 508
	Plummer block housing units, flake graphite cast iron housing with short base
	with grub screws in inner ring..... 510
	Two-bolt flanged housing units, oval version
	with grub screws in inner ring..... 514
	with adapter sleeve..... 520
	Four-bolt flanged housing units, square version
	with grub screws in inner ring..... 522
	with adapter sleeve..... 528
	Four-bolt flanged housing units, round version
	with grub screws in inner ring..... 530
	with adapter sleeve..... 536
	Take-up housing units, for linear motion
	with grub screws in inner ring..... 538
	with adapter sleeve..... 544
	Take-up housing units, for swivel motion
	with grub screws in inner ring..... 546

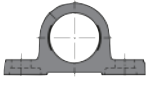
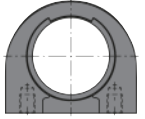

**Possible combinations of radial insert ball bearings and housings**

<b>Radial insert ball bearing</b>		Housing	
		Plummer block housing	
			
Designation		<b>P</b>	<b>PA</b>
Shaft diameter d			
<b>UC</b> 12 mm – 90 mm <i>1/2" – 3 1/2"</i>		<b>UCP</b> page 502	<b>UCPA</b> page 510
<b>UK</b> 20 mm – 80 mm		<b>UKP</b> page 508	Available by agreement

Catalogue range, for dimension tables see pages indicated.  
Other dimensions and combinations available by agreement.

Two-bolt flanged housing	Four-bolt flanged housing		Take-up housing	
<b>FL</b>	<b>F</b>	<b>FC</b>	<b>T</b>	<b>FA</b>
<b>UCFL</b> page 514	<b>UCF</b> page 522	<b>UCFC</b> page 530	<b>UCT</b> page 538	<b>UCFA</b> page 546
<b>UKFL</b> page 520	<b>UKF</b> page 528	<b>UKFC</b> page 536	<b>UKT</b> page 544	Available by agreement



# Product overview Housing units

## Plummer block housing units

Flake graphite cast iron housing with long base



Flake graphite cast iron housing with short base



## Two-bolt flanged housing units

Flake graphite cast iron housing



### Four-bolt flanged housing units

Flake graphite cast iron housing

UCF



UKF



UCFC



UKFC



### Take-up housing units

Flake graphite cast iron housing

UCT



UKT



UCFA



# Housing units

## Features

These housing units are available as plummer block housing units, flanged housing units and take-up housing units. The units are ready-to-fit and comprise FAG flake graphite cast iron housings in which FAG Black Series radial insert ball bearings are fitted.

Due to the spherical outer ring of the bearing and the concave housing bore, housing units can compensate for static misalignments of the shaft, see page 497.

The housings are screw mounted on the adjacent construction. Less stringent tolerances are sufficient for the screw mounting surfaces, see page 497.

## Housing units with flake graphite cast iron housing

The flake graphite cast iron housings are single piece components in accordance with JIS B 1559 and have high radial and axial load carrying capacity, see page 497.

The housing has a lubrication groove for relubrication of the radial insert ball bearing. The housing has a lubrication hole with an M6 thread for a lubrication nipple.

The housings have a primer paint coating as anti-corrosion protection of colour RAL 9005 (black).



In order to ensure function and reliability under all operating conditions, the bearings and housings are matched to each other with a defined swivel moment after mounting.

All catalogue cast iron units have a mean swivel moment (as standard); further designs with a smaller or greater swivel moment, depending on their application, are available by agreement.

## Housing material

The material used for the flake graphite cast iron housings is cast iron in accordance with JIS G 5501.

## Plummer block housing units

Plummer block housing units have a housing with a short or long base and are screw mounted to the adjacent construction through slot holes or fixing holes, *Figure 1* and *Figure 2*, page 495.

Plummer block housing units with a long base are available either with radial insert ball bearings UC with grub screws or with radial insert ball bearings UK with adapter sleeves, see dimension table.

UCP

*Figure 1*  
Plummer block housing unit,  
flake graphite cast iron housing  
with long base

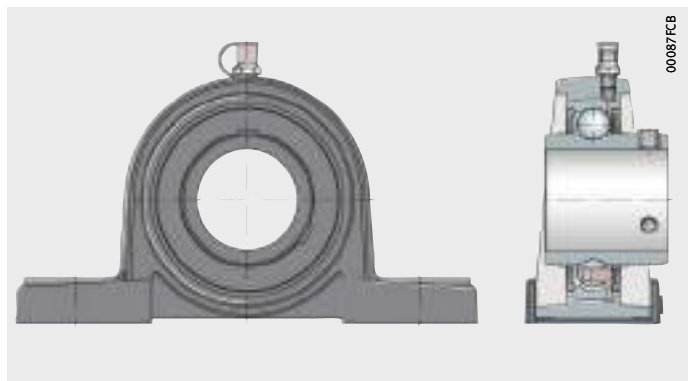



**UCPA**

*Figure 2*  
Plummer block housing unit  
with short base

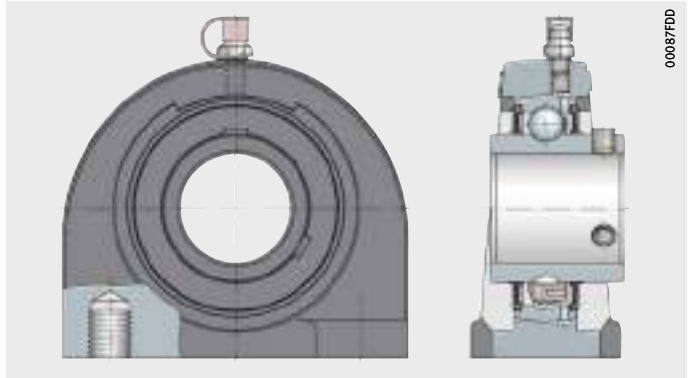

**Flanged housing units**

Flanged housing units are available as two-bolt and four-bolt units, *Figure 3 to Figure 5*, page 496. The housings are oval, square or round in shape. The housings have through holes for location purposes.

Flanged housing units are available either with radial insert ball bearings UC with grub screws or with radial insert ball bearings UK with adapter sleeves, see dimension table.

**UCFL**

*Figure 3*  
Two-bolt flanged housing unit,  
oval version

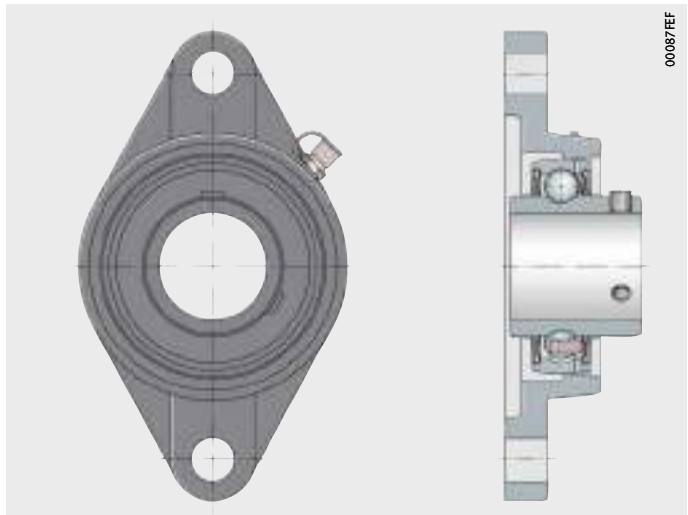

**UCF**

*Figure 4*  
Four-bolt flanged housing unit,  
square version

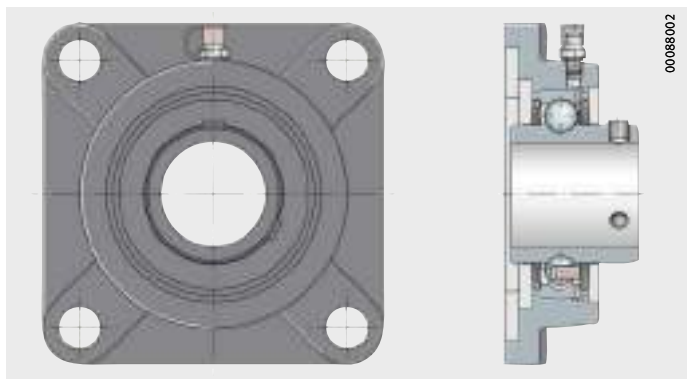

# Housing units

**UCFC**

*Figure 5*  
Four-bolt flanged housing unit,  
round version

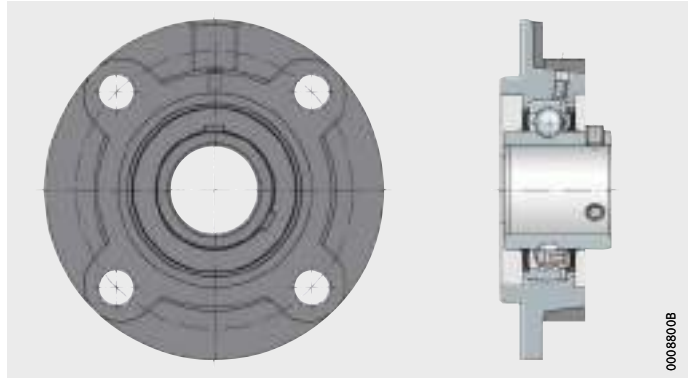

**Take-up housing units**

Take-up housing units can be moved or swivelled, *Figure 6* and *Figure 7*. They are used where shafts must carry out long displacement motions.

**UCT**

*Figure 6*  
Take-up housing unit  
for linear motion

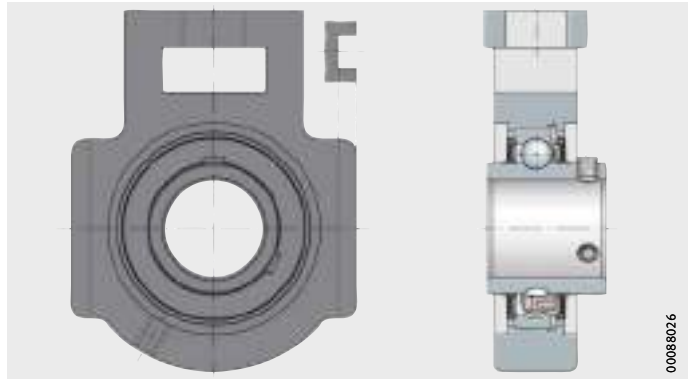

**UCFA**

*Figure 7*  
Take-up housing unit  
for swivel motion

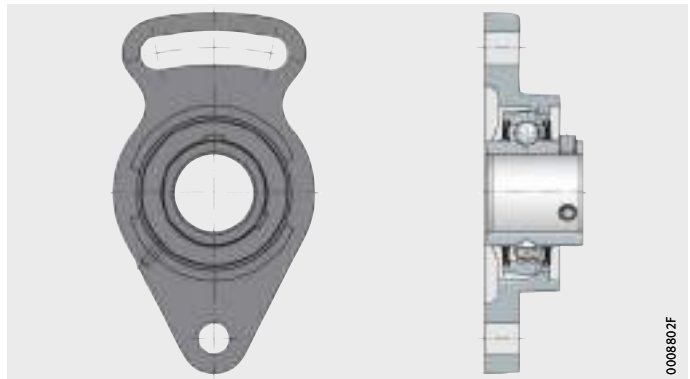

**Operating temperature**

Housing units are suitable for operating temperatures of  $-20\text{ }^{\circ}\text{C}$  to  $+100\text{ }^{\circ}\text{C}$ . Temperature peaks of up to  $+120\text{ }^{\circ}\text{C}$  are possible for short periods.

## **Design and safety guidelines**

### **Compensation of static misalignments**

Units with a spherical outer ring and concave housing bore can compensate static misalignments of the shaft, see page 477.

### **Load carrying capacity of housings**

Due to their versatile characteristics, FAG housing units can be easily used in almost all industrial sectors.

### **Radial load carrying capacity**

Flake graphite cast iron housings can support the same radial loads as the radial insert ball bearings fitted. The static load carrying capacity  $C_{0r}$  of the radial insert ball bearings is stated in the dimension tables.



Where shock loads are present, appropriate safety factors must be applied. In this case, please contact us.

### **Axial load carrying capacity**

The axial load carrying capacity of flake graphite cast iron housings is restricted to  $0,5 \times C_{0r}$ .

## **Load carrying capacity and speed limits of radial insert ball bearings**



In the design of housing units, attention must be paid to the load carrying capacity and speed limits of the radial insert ball bearings fitted:

- speed limits, see page 478
- dimension table, see page 482.

## **Design of adjacent construction**

The permissible shaft tolerance is dependent on the speed and load. Shafts of the tolerance classes h6 © to h9 © can be used.

### **Screw mounting surfaces**

Recommendations for the screw mounting surfaces are as follows:

- roughness of the screw mounting surface max. Ra 12,5 (Rzmax 63)
- geometrical and positional tolerance 0,04/100 concave, spherical not permissible.
- In the event of high loads occurring parallel to the mounting surface of plummer block housing units (in the case of cast iron housing with long base), the use of additional dowel pins to DIN EN ISO 8752 is recommended. In this case, through holes (see centre punch mark for housing ASE) must be applied, see *Figure 8*, page 499.



# Housing units

<b>Fixing screws</b>	<p>The screw connection should be designed in accordance with the state of the art; friction coefficient <math>\mu = 0,12</math> (90%).</p> <p>Screws of grade 8.8 or better can be used for fixing. The maximum tightening torques applicable to this screw grade must not be exceeded even if screws of a higher grade are used.</p> <p>In principle, we recommend that the screw connection should only be tightened to 70% of the values stated in the standard.</p> <p>For fixing, hexagonal socket head screws in accordance with DIN EN ISO 4762 or hexagonal socket head screws with a coarse pitch full thread in accordance with DIN EN ISO 4017 should be used. The screws should be combined as a minimum with a washer in accordance with DIN EN ISO 7089 or DIN EN ISO 7090.</p> <p>Screws and accessories for location are not included in the delivery.</p>
<b>Mounting and dismounting</b>	<p>Radial insert ball bearings must be handled with care before and during mounting. Their trouble-free operation is also dependent on the care taken during mounting.</p>
<b>Delivered condition</b>	<p>The housings have a coating of black primer paint (RAL 9005).</p> <p>The radial insert ball bearings are greased using a grease in grease group GA13, see Catalogue HR 1, Rolling Bearings.</p> <p>The housing units are supplied with a loose packed lubrication nipple and integrated end cap for the lubrication nipple as well as an Allen key.</p>
<b>Storage and shelf life</b>	<p>The units should be stored in dry, clean rooms with a temperature as constant as possible and at a relative humidity of max. 65%.</p> <p>The storage life of radial insert ball bearings is limited by the shelf life of the grease, see chapter Technical principles in Catalogue HR 1, Rolling Bearings.</p>
<b>Removal from packaging</b>	<p>Perspiration causes corrosion. Hands must therefore be kept clean and dry. Bearings should not be removed from their original packaging until immediately before mounting.</p>
<b>Preparation for mounting</b>	<p>The following preparatory measures for mounting should be taken:</p> <ul style="list-style-type: none"><li>■ Ensure that the mounting tools and fixing screws are present.</li><li>■ Clean the shaft and remove any burrs.</li><li>■ Inspect the bearing seating surfaces on the shaft.</li><li>■ Keep bearing seating surfaces clean, dry and free of grease.</li></ul>

## Mounting of plummer block and flanged housing units



The assembly area should be as dry and clean as possible:

- The specified shaft tolerances must be observed, see page 497.
- Mounting forces must never be directed through the rolling elements.
- Blows should never be applied directly to the bearing rings and flinger shields or seals.
- Observe the tightening torques  $M_A$  for grub screws and adapter sleeve, see tables, page 500.

If the following sequence is observed, the bearing will align itself on the shaft in such a way that no undesirable stresses occur:

- ▶ Slide the housing unit onto the shaft and align it with the fixing holes in the adjacent construction, *Figure 8*.
- ▶ Fit dowel pins if necessary.
- ▶ Tighten the fixing screws for all housings finger tight in the adjacent construction as far as possible and align the shaft, *Figure 9*, page 500.
- ▶ Tighten both grub screws in the inner ring (for radial insert ball bearing UC) or the locknut of the adapter sleeve (for radial insert ball bearing UK) using a tightening torque (with an additional adapter if necessary) to the specified tightening torque, *Figure 10*, page 500.
- ▶ Locate the housings on the adjacent construction using the recommended tightening torque, see page 497.

① Position of additional through hole for location of dowel pins in accordance with DIN EN ISO 8752 (in the event of high loads occurring parallel to the mounting surface; for housing P)

*Figure 8*  
Sliding the unit onto the shaft

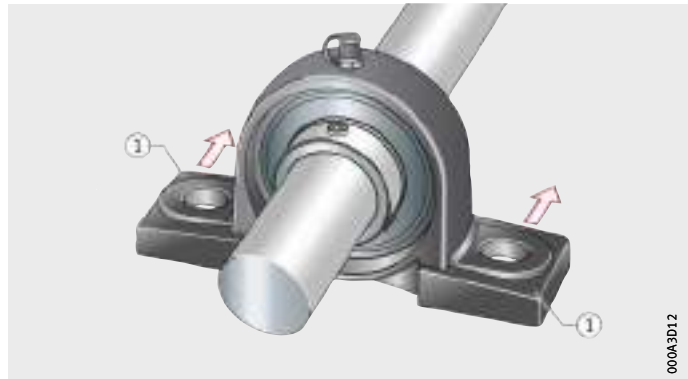

# Housing units

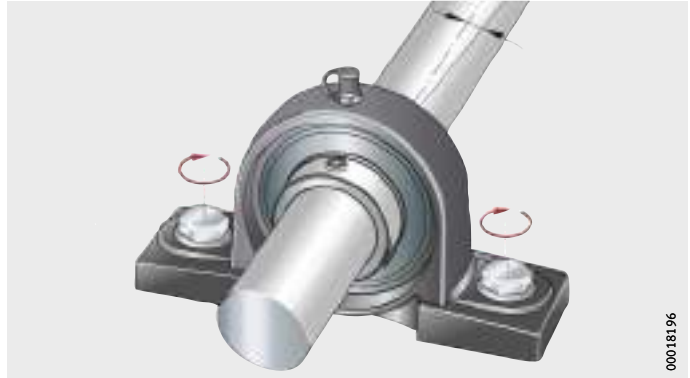

*Figure 9*  
Screw mounting  
the housing finger tight

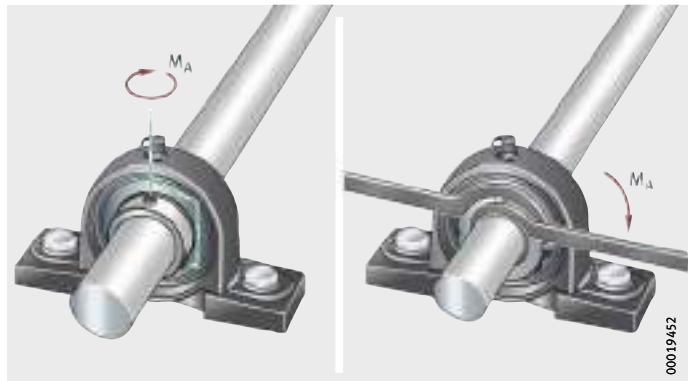

*Figure 10*  
Fully tightening the grub screws or  
locknut in the inner ring

## Tightening torques for grub screws

Width across flats W		Thread		Tightening torque <sup>1)</sup> M <sub>A</sub> Nm
mm	inch	ISO	UNF	
3	1/8	M6×0,75	1/4"-28	6
4	5/32	M8×1	5/16"-24	14
5	3/16	M10×1,25	3/8"-24	26
6	1/4	M12×1,5	1/2"-20	42

<sup>1)</sup> The tightening torques are valid for original FAG grub screws only.

## Tightening torques for locknut

Locknut	Tightening torque $M_A$ Nm
AN05	25
AN06	30
AN07	40
AN08	50
AN09	60
AN10	75
AN11	100
AN12	130
AN13	150
AN15	170
AN16	200
AN17	230
AN18	270

- Dismounting** The units are dismounted in the reverse sequence.
- ▶ Loosen the grub screws in the inner ring or the locknut of the adapter sleeve.
  - ▶ Unscrew the housing.

- Accuracy** The flake graphite cast iron housings conform to JIS B 1559.  
Accuracy of fitted radial insert ball bearings: see page 479.

- Dimensional tolerances** The dimensional tolerances for the machined surfaces of the flake graphite cast iron housings are  $\pm 0,25$  mm.  
Dimensions without tolerance conform to JIS B 0403:
- unfinished dimensions to Table 1, class CT 10
  - finished dimensions to Table 5.



# Plummer block housing units

Flake graphite cast iron housing  
with long base  
With grub screws in inner ring

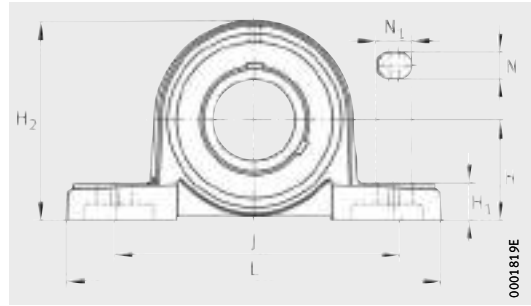

UCP

**Dimension table** - Dimensions in mm and inch

Designation			Mass m ≈ kg	Dimensions					
Unit	Housing	Radial insert ball bearing		d		H	J	L	A
				mm	inch				
UCP201	P203	UC201	0,7	12	–	30,2	95	127	38
UCP201-08	P203	UC201-08	0,69	12,7	1/2	30,2	95	127	38
UCP202-09	P203	UC202-09	0,69	14,288	9/16	30,2	95	127	38
UCP202	P203	UC202	0,68	15	–	30,2	95	127	38
UCP202-10	P203	UC202-10	0,68	15,875	5/8	30,2	95	127	38
UCP203	P203	UC203	0,67	17	–	30,2	95	127	38
UCP203-11	P203	UC203-11	0,67	17,463	11/16	30,2	95	127	38
UCP204-12	P204	UC204-12	0,66	19,05	3/4	33,3	95	127	38
UCP204	P204	UC204	0,65	20	–	33,3	95	127	38
UCP205-13	P205	UC205-13	0,83	20,638	13/16	36,5	105	140	38
UCP205-14	P205	UC205-14	0,82	22,225	7/8	36,5	105	140	38
UCP205-15	P205	UC205-15	0,81	23,813	15/16	36,5	105	140	38
UCP205	P205	UC205	0,79	25	–	36,5	105	140	38
UCP205-16	P205	UC205-16	0,79	25,4	1	36,5	105	140	38
UCP206-17	P206	UC206-17	1,33	26,988	11/16	42,9	121	165	48
UCP206-18	P206	UC206-18	1,31	28,575	11/8	42,9	121	165	48
UCP206	P206	UC206	1,29	30	–	42,9	121	165	48
UCP206-19	P206	UC206-19	1,29	30,163	13/16	42,9	121	165	48
UCP206-20	P206	UC206-20	1,27	31,75	11/4	42,9	121	165	48
UCP207-20	P207	UC207-20	1,6	31,75	11/4	47,6	127	167	48
UCP207-21	P207	UC207-21	1,58	33,338	15/16	47,6	127	167	48
UCP207-22	P207	UC207-22	1,55	34,925	13/8	47,6	127	167	48
UCP207	P207	UC207	1,55	35	–	47,6	127	167	48
UCP207-23	P207	UC207-23	1,52	36,513	17/16	47,6	127	167	48
UCP208-24	P208	UC208-24	1,89	38,1	11/2	49,2	137	184	54
UCP208-25	P208	UC208-25	1,85	39,688	19/16	49,2	137	184	54
UCP208	P208	UC208	1,84	40	–	49,2	137	184	54



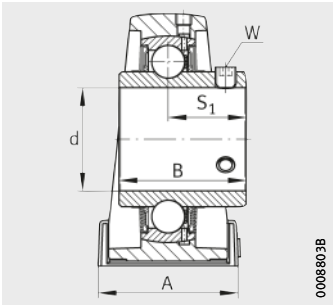

UCP

0008803B

H <sub>1</sub>	H <sub>2</sub>	N	N <sub>1</sub>	B	S <sub>1</sub>	Width across flats		Load carrying capacity Bearing		
						W		Basic load ratings		Fatigue limit load
						mm	inch	dyn. C <sub>r</sub> N	stat. C <sub>0r</sub> N	C <sub>ur</sub> N
14	62	13	19	31	18,3	3	–	13 600	6 600	335
14	62	13	19	31	18,3	–	1/8	13 600	6 600	335
14	62	13	19	31	18,3	–	1/8	13 600	6 600	335
14	62	13	19	31	18,3	3	–	13 600	6 600	335
14	62	13	19	31	18,3	–	1/8	13 600	6 600	335
14	62	13	19	31	18,3	3	–	13 600	6 600	335
14	62	13	19	31	18,3	–	1/8	13 600	6 600	335
14	65	13	19	31	18,3	–	1/8	13 600	6 600	335
14	65	13	19	31	18,3	3	–	13 600	6 600	335
15	71	13	19	34,1	19,8	–	1/8	14 900	7 800	395
15	71	13	19	34,1	19,8	–	1/8	14 900	7 800	395
15	71	13	19	34,1	19,8	–	1/8	14 900	7 800	395
15	71	13	19	34,1	19,8	3	–	14 900	7 800	395
15	71	13	19	34,1	19,8	–	1/8	14 900	7 800	395
17	83	17	21	38,1	22,2	–	1/8	20 700	11 300	570
17	83	17	21	38,1	22,2	–	1/8	20 700	11 300	570
17	83	17	21	38,1	22,2	3	–	20 700	11 300	570
17	83	17	21	38,1	22,2	–	1/8	20 700	11 300	570
17	83	17	21	38,1	22,2	–	1/8	20 700	11 300	570
18	93	17	21	42,9	25,4	–	5/32	27 500	15 300	770
18	93	17	21	42,9	25,4	–	5/32	27 500	15 300	770
18	93	17	21	42,9	25,4	–	5/32	27 500	15 300	770
18	93	17	21	42,9	25,4	4	–	27 500	15 300	770
18	93	17	21	42,9	25,4	–	5/32	27 500	15 300	770
18	98	17	21	49,2	30,2	–	5/32	34 500	19 800	1010
18	98	17	21	49,2	30,2	–	5/32	34 500	19 800	1010
18	98	17	21	49,2	30,2	4	–	34 500	19 800	1010



# Plummer block housing units

Flake graphite cast iron housing  
with long base  
With grub screws in inner ring

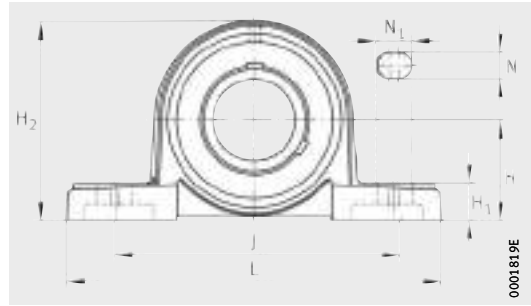

UCP

Dimension table (continued) · Dimensions in mm and inch

Designation			Mass m ≈ kg	Dimensions					
Unit	Housing	Radial insert ball bearing		d		H	J	L	A
				mm	inch				
UCP209-26	P209	UC209-26	2,29	41,275	15/8	54	146	190	54
UCP209-27	P209	UC209-27	2,25	42,863	111/16	54	146	190	54
UCP209-28	P209	UC209-28	2,21	44,45	13/4	54	146	190	54
UCP209	P209	UC209	2,2	45	–	54	146	190	54
UCP210-29	P210	UC210-29	2,89	46,038	113/16	57,2	159	206	60
UCP210-30	P210	UC210-30	2,85	47,625	17/8	57,2	159	206	60
UCP210-31	P210	UC210-31	2,8	49,213	115/16	57,2	159	206	60
UCP210	P210	UC210	2,77	50	–	57,2	159	206	60
UCP210-32	P210	UC210-32	2,75	50,8	2	57,2	159	206	60
UCP211-32	P211	UC211-32	3,56	50,8	2	63,5	171	219	60
UCP211-33	P211	UC211-33	3,5	52,388	21/16	63,5	171	219	60
UCP211-34	P211	UC211-34	3,44	53,975	21/8	63,5	171	219	60
UCP211	P211	UC211	3,41	55	–	63,5	171	219	60
UCP211-35	P211	UC211-35	3,39	55,563	23/16	63,5	171	219	60
UCP212-36	P212	UC212-36	4,75	57,15	21/4	69,8	184	241	70
UCP212-37	P212	UC212-37	4,68	58,738	25/16	69,8	184	241	70
UCP212	P212	UC212	4,62	60	–	69,8	184	241	70
UCP212-38	P212	UC212-38	4,6	60,325	23/8	69,8	184	241	70
UCP212-39	P212	UC212-39	4,53	61,913	27/16	69,8	184	241	70
UCP213-40	P213	UC213-40	5,63	63,5	21/2	76,2	203	265	70
UCP213	P213	UC213	5,55	65	–	76,2	203	265	70
UCP213-41	P213	UC213-41	5,55	65,088	29/16	76,2	203	265	70
UCP214-42	P214	UC214-42	6,29	66,675	25/8	79,4	210	266	72
UCP214-43	P214	UC214-43	6,2	68,263	211/16	79,4	210	266	72
UCP214-44	P214	UC214-44	6,1	69,85	23/4	79,4	210	266	72
UCP214	P214	UC214	6,1	70	–	79,4	210	266	72

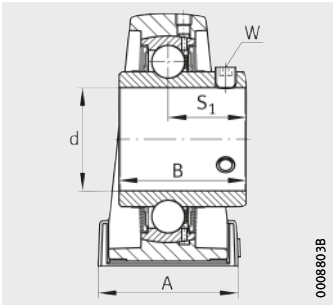

UCP

H <sub>1</sub>						Width across flats		Load carrying capacity Bearing		
								Basic load ratings		Fatigue limit load C <sub>ur</sub> N
						H <sub>2</sub>	N	N <sub>1</sub>	B	
20	106	17	21	49,2	30,2	–	5/32	34 500	20 400	1 030
20	106	17	21	49,2	30,2	–	5/32	34 500	20 400	1 030
20	106	17	21	49,2	30,2	–	5/32	34 500	20 400	1 030
20	106	17	21	49,2	30,2	4	–	34 500	20 400	1 030
21	114	20	25	51,6	32,6	–	3/16	37 500	23 200	1 180
21	114	20	25	51,6	32,6	–	3/16	37 500	23 200	1 180
21	114	20	25	51,6	32,6	–	3/16	37 500	23 200	1 180
21	114	20	25	51,6	32,6	5	–	37 500	23 200	1 180
21	114	20	25	51,6	32,6	–	3/16	37 500	23 200	1 180
23	126	20	25	55,6	33,4	–	3/16	46 000	29 000	1 480
23	126	20	25	55,6	33,4	–	3/16	46 000	29 000	1 480
23	126	20	25	55,6	33,4	–	3/16	46 000	29 000	1 480
23	126	20	25	55,6	33,4	5	–	46 000	29 000	1 480
23	126	20	25	55,6	33,4	–	3/16	46 000	29 000	1 480
25	138	20	25	65,1	39,7	–	3/16	56 000	36 000	1 820
25	138	20	25	65,1	39,7	–	3/16	56 000	36 000	1 820
25	138	20	25	65,1	39,7	5	–	56 000	36 000	1 820
25	138	20	25	65,1	39,7	–	3/16	56 000	36 000	1 820
25	138	20	25	65,1	39,7	–	3/16	56 000	36 000	1 820
27	151	25	29	65,1	39,7	–	1/4	61 000	40 000	2 030
27	151	25	29	65,1	39,7	6	–	61 000	40 000	2 030
27	151	25	29	65,1	39,7	–	1/4	61 000	40 000	2 030
27	157	25	31	74,6	44,4	–	1/4	66 000	44 000	2 230
27	157	25	31	74,6	44,4	–	1/4	66 000	44 000	2 230
27	157	25	31	74,6	44,4	–	1/4	66 000	44 000	2 230
27	157	25	31	74,6	44,4	6	–	66 000	44 000	2 230



# Plummer block housing units

Flake graphite cast iron housing  
with long base  
With grub screws in inner ring

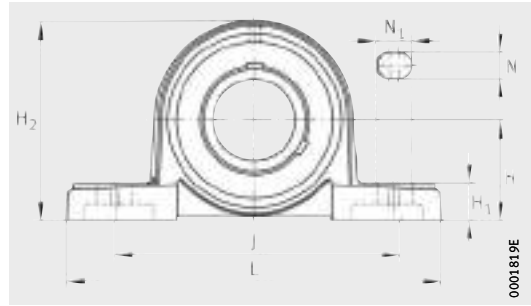

UCP

**Dimension table** (continued) · Dimensions in mm and inch

Designation			Mass m ≈ kg	Dimensions					
Unit	Housing	Radial insert ball bearing		d		H	J	L	A
				mm	inch				
<b>UCP215-45</b>	P215	UC215-45	6,9	<b>71,438</b>	<b>2<sup>13</sup>/<sub>16</sub></b>	82,6	217	275	74
<b>UCP215-46</b>	P215	UC215-46	6,81	<b>73,025</b>	<b>2<sup>7</sup>/<sub>8</sub></b>	82,6	217	275	74
<b>UCP215-47</b>	P215	UC215-47	6,7	<b>74,613</b>	<b>2<sup>15</sup>/<sub>16</sub></b>	82,6	217	275	74
<b>UCP215</b>	P215	UC215	6,67	<b>75</b>	–	82,6	217	275	74
<b>UCP215-48</b>	P215	UC215-48	6,58	<b>76,2</b>	<b>3</b>	82,6	217	275	74
<b>UCP216-49</b>	P216	UC216-49	8,53	<b>77,788</b>	<b>3<sup>1</sup>/<sub>16</sub></b>	88,9	232	292	78
<b>UCP216-50</b>	P216	UC216-50	8,4	<b>79,375</b>	<b>3<sup>1</sup>/<sub>8</sub></b>	88,9	232	292	78
<b>UCP216</b>	P216	UC216	8,4	<b>80</b>	–	88,9	232	292	78
<b>UCP216-51</b>	P216	UC216-51	8,28	<b>80,963</b>	<b>3<sup>3</sup>/<sub>16</sub></b>	88,9	232	292	78
<b>UCP217-52</b>	P217	UC217-52	10,3	<b>82,55</b>	<b>3<sup>1</sup>/<sub>4</sub></b>	95,2	247	310	83
<b>UCP217-53</b>	P217	UC217-53	10,17	<b>84,138</b>	<b>3<sup>5</sup>/<sub>16</sub></b>	95,2	247	310	83
<b>UCP217</b>	P217	UC217	10,1	<b>85</b>	–	95,2	247	310	83
<b>UCP217-55</b>	P217	UC217-55	9,9	<b>87,313</b>	<b>3<sup>7</sup>/<sub>16</sub></b>	95,2	247	310	83
<b>UCP218-56</b>	P218	UC218-56	12,3	<b>88,9</b>	<b>3<sup>1</sup>/<sub>2</sub></b>	101,6	262	327	88
<b>UCP218</b>	P218	UC218	12,2	<b>90</b>	–	101,6	262	327	88

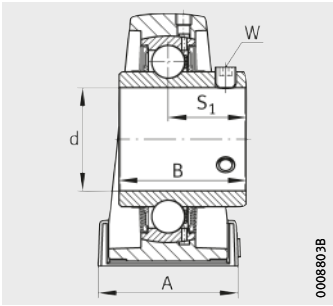

UCP

0008803B

UCP						Width across flats		Load carrying capacity Bearing		
								Basic load ratings		Fatigue limit load $C_{ur}$ N
						$H_1$	$H_2$	N	$N_1$	
28	163	25	31	77,8	44,5	–	1/4	66 000	44 500	2 240
28	163	25	31	77,8	44,5	–	1/4	66 000	44 500	2 240
28	163	25	31	77,8	44,5	–	1/4	66 000	44 500	2 240
28	163	25	31	77,8	44,5	6	–	66 000	44 500	2 240
28	163	25	31	77,8	44,5	–	1/4	66 000	44 500	2 240
30	175	25	31	82,6	49,3	–	1/4	76 000	54 000	2 600
30	175	25	31	82,6	49,3	–	1/4	76 000	54 000	2 600
30	175	25	31	82,6	49,3	6	–	76 000	54 000	2 600
30	175	25	31	82,6	49,3	–	1/4	76 000	54 000	2 600
32	187	25	31	85,7	51,6	–	1/4	88 000	64 000	2 950
32	187	25	31	85,7	51,6	–	1/4	88 000	64 000	2 950
32	187	25	31	85,7	51,6	6	–	88 000	64 000	2 950
32	187	25	31	85,7	51,6	–	1/4	88 000	64 000	2 950
33	200	27	33	96	56,3	–	1/4	102 000	72 000	3 250
33	200	27	33	96	56,3	6	–	102 000	72 000	3 250



# Plummer block housing units

Flake graphite cast iron housing  
with long base  
With adapter sleeve

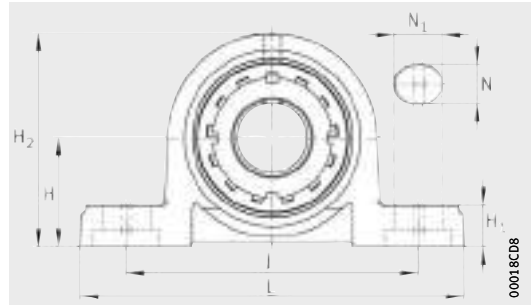

UKP

**Dimension table** - Dimensions in mm

Designation			Mass	Dimensions				
Unit	Housing	Radial insert ball bearing		d	H	J	L	A
			m					
			≈ kg					
<b>UKP205</b>	P205	UK205	0,84	<b>20</b>	36,5	105	140	38
<b>UKP206</b>	P206	UK206	1,36	<b>25</b>	42,9	121	165	48
<b>UKP207</b>	P207	UK207	1,63	<b>30</b>	47,6	127	167	48
<b>UKP208</b>	P208	UK208	1,92	<b>35</b>	49,2	137	184	54
<b>UKP209</b>	P209	UK209	2,33	<b>40</b>	54	146	190	54
<b>UKP210</b>	P210	UK210	2,95	<b>45</b>	57,2	159	206	60
<b>UKP211</b>	P211	UK211	3,58	<b>50</b>	63,5	171	219	60
<b>UKP212</b>	P212	UK212	4,71	<b>55</b>	69,8	184	241	70
<b>UKP213</b>	P213	UK213	5,71	<b>60</b>	76,2	203	265	70
<b>UKP215</b>	P215	UK215	7,11	<b>65</b>	82,6	217	275	74
<b>UKP216</b>	P216	UK216	8,86	<b>70</b>	88,9	232	292	78
<b>UKP217</b>	P217	UK217	10,58	<b>75</b>	95,2	247	310	83
<b>UKP218</b>	P218	UK218	12,71	<b>80</b>	101,6	262	327	88

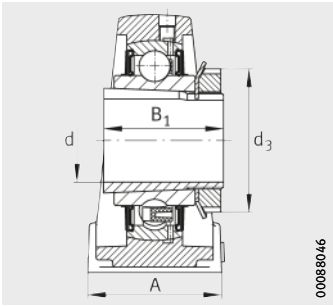

UKP

00088046

						Load carrying capacity Bearing		
						Basic load ratings		Fatigue limit load
$H_1$	$H_2$	N	$N_1$	$B_1$	$d_3$ max.	dyn. $C_r$ N	stat. $C_{0r}$ N	$C_{ur}$ N
15	71	13	19	35	38	14 900	7 800	395
17	83	17	21	38	45	20 700	11 300	570
18	93	17	21	43	52	27 500	15 300	770
18	98	17	21	46	58	34 500	19 800	1 010
20	106	17	21	50	65	34 500	20 400	1 030
21	114	20	25	55	70	37 500	23 200	1 180
23	126	20	25	59	75	46 000	29 000	1 480
25	138	20	25	62	80	56 000	36 000	1 820
27	151	25	29	65	85	61 000	40 000	2 030
28	163	25	31	73	98	66 000	44 500	2 240
30	175	25	31	78	105	76 000	54 000	2 600
32	187	25	31	82	110	88 000	64 000	2 950
33	200	27	33	86	120	102 000	72 000	3 250



# Plummer block housing units

Flake graphite cast iron housing  
with short base  
With grub screws in inner ring

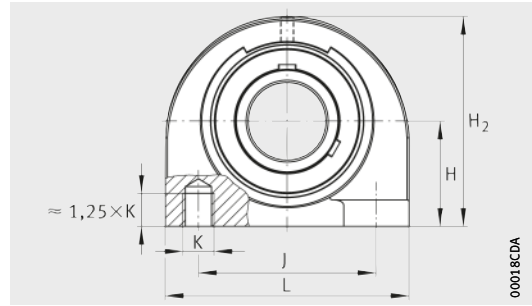

UCPA

**Dimension table** - Dimensions in mm and inch

Designation			Mass m ≈ kg	Dimensions				
Unit	Housing	Radial insert ball bearing		d		H	J	L
				mm	inch			
<b>UCPA201</b>	PA204	UC201	0,65	<b>12</b>	–	30,2	52	76
<b>UCPA201-08</b>	PA204	UC201-08	0,65	<b>12,7</b>	<b>1/2</b>	30,2	52	76
<b>UCPA202-09</b>	PA204	UC202-09	0,64	<b>14,288</b>	<b>9/16</b>	30,2	52	76
<b>UCPA202</b>	PA204	UC202	0,64	<b>15</b>	–	30,2	52	76
<b>UCPA202-10</b>	PA204	UC202-10	0,63	<b>15,875</b>	<b>5/8</b>	30,2	52	76
<b>UCPA203</b>	PA204	UC203	0,63	<b>17</b>	–	30,2	52	76
<b>UCPA203-11</b>	PA204	UC203-11	0,63	<b>17,463</b>	<b>11/16</b>	30,2	52	76
<b>UCPA204-12</b>	PA204	UC204-12	0,62	<b>19,05</b>	<b>3/4</b>	30,2	52	76
<b>UCPA204</b>	PA204	UC204	0,61	<b>20</b>	–	30,2	52	76
<b>UCPA205-13</b>	PA205	UC205-13	0,87	<b>20,638</b>	<b>13/16</b>	36,5	56	84
<b>UCPA205-14</b>	PA205	UC205-14	0,86	<b>22,225</b>	<b>7/8</b>	36,5	56	84
<b>UCPA205-15</b>	PA205	UC205-15	0,84	<b>23,813</b>	<b>15/16</b>	36,5	56	84
<b>UCPA205</b>	PA205	UC205	0,83	<b>25</b>	–	36,5	56	84
<b>UCPA205-16</b>	PA205	UC205-16	0,83	<b>25,4</b>	<b>1</b>	36,5	56	84
<b>UCPA206-17</b>	PA206	UC206-17	1,26	<b>26,988</b>	<b>11/16</b>	42,9	66	94
<b>UCPA206-18</b>	PA206	UC206-18	1,24	<b>28,575</b>	<b>11/8</b>	42,9	66	94
<b>UCPA206</b>	PA206	UC206	1,22	<b>30</b>	–	42,9	66	94
<b>UCPA206-19</b>	PA206	UC206-19	1,22	<b>30,163</b>	<b>13/16</b>	42,9	66	94
<b>UCPA206-20</b>	PA206	UC206-20	1,2	<b>31,75</b>	<b>11/4</b>	42,9	66	94



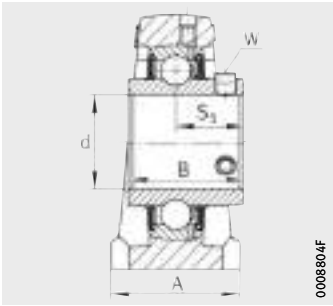

UCPA

					Width across flats		Load carrying capacity Bearing		
					W		Basic load ratings		Fatigue limit load
A	H <sub>2</sub>	K	B	S <sub>1</sub>			dyn. C <sub>r</sub>	stat. C <sub>0r</sub>	C <sub>ur</sub>
					mm	inch	N	N	N
38	62	M10	31	18,3	3	–	13 600	6 600	335
38	62	M10	31	18,3	–	1/8	13 600	6 600	335
38	62	M10	31	18,3	–	1/8	13 600	6 600	335
38	62	M10	31	18,3	3	–	13 600	6 600	335
38	62	M10	31	18,3	–	1/8	13 600	6 600	335
38	62	M10	31	18,3	3	–	13 600	6 600	335
38	62	M10	31	18,3	–	1/8	13 600	6 600	335
38	62	M10	31	18,3	–	1/8	13 600	6 600	335
38	62	M10	31	18,3	3	–	13 600	6 600	335
38	72	M10	34,1	19,8	–	1/8	14 900	7 800	395
38	72	M10	34,1	19,8	–	1/8	14 900	7 800	395
38	72	M10	34,1	19,8	–	1/8	14 900	7 800	395
38	72	M10	34,1	19,8	3	–	14 900	7 800	395
38	72	M10	34,1	19,8	–	1/8	14 900	7 800	395
48	84	M14	38,1	22,2	–	1/8	20 700	11 300	570
48	84	M14	38,1	22,2	–	1/8	20 700	11 300	570
48	84	M14	38,1	22,2	3	–	20 700	11 300	570
48	84	M14	38,1	22,2	–	1/8	20 700	11 300	570
48	84	M14	38,1	22,2	–	1/8	20 700	11 300	570



# Plummer block housing units

Flake graphite cast iron housing  
with short base  
With grub screws in inner ring

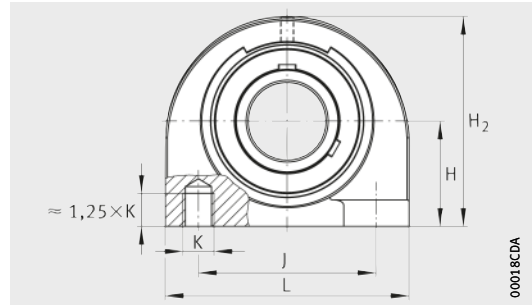

UCPA

**Dimension table** (continued) · Dimensions in mm and inch

Designation			Mass m ≈ kg	Dimensions				
Unit	Housing	Radial insert ball bearing		d		H	J	L
				mm	inch			
<b>UCPA207-20</b>	PA207	UC207-20	1,75	<b>31,75</b>	<b>1 1/4</b>	47,6	80	110
<b>UCPA207-21</b>	PA207	UC207-21	1,73	<b>33,338</b>	<b>1 5/16</b>	47,6	80	110
<b>UCPA207-22</b>	PA207	UC207-22	1,7	<b>34,925</b>	<b>1 3/8</b>	47,6	80	110
<b>UCPA207</b>	PA207	UC207	1,7	<b>35</b>	–	47,6	80	110
<b>UCPA207-23</b>	PA207	UC207-23	1,67	<b>36,513</b>	<b>1 7/16</b>	47,6	80	110
<b>UCPA208-24</b>	PA208	UC208-24	1,96	<b>38,1</b>	<b>1 1/2</b>	49,2	84	116
<b>UCPA208-25</b>	PA208	UC208-25	1,92	<b>39,688</b>	<b>1 9/16</b>	49,2	84	116
<b>UCPA208</b>	PA208	UC208	1,91	<b>40</b>	–	49,2	84	116
<b>UCPA209-26</b>	PA209	UC209-26	2,28	<b>41,275</b>	<b>1 5/8</b>	54,2	90	120
<b>UCPA209-27</b>	PA209	UC209-27	2,24	<b>42,863</b>	<b>1 11/16</b>	54,2	90	120
<b>UCPA209-28</b>	PA209	UC209-28	2,2	<b>44,45</b>	<b>1 3/4</b>	54,2	90	120
<b>UCPA209</b>	PA209	UC209	2,19	<b>45</b>	–	54,2	90	120
<b>UCPA210-29</b>	PA210	UC210-29	2,9	<b>46,038</b>	<b>1 13/16</b>	57,2	94	130
<b>UCPA210-30</b>	PA210	UC210-30	2,85	<b>47,625</b>	<b>1 7/8</b>	57,2	94	130
<b>UCPA210-31</b>	PA210	UC210-31	2,8	<b>49,213</b>	<b>1 15/16</b>	57,2	94	130
<b>UCPA210</b>	PA210	UC210	2,78	<b>50</b>	–	57,2	94	130
<b>UCPA210-32</b>	PA210	UC210-32	2,76	<b>50,8</b>	<b>2</b>	57,2	94	130

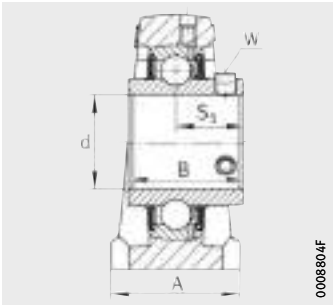

0008804F

UCPA

					Width across flats		Load carrying capacity		
							Basic load ratings		Fatigue limit load
A	H <sub>2</sub>	K	B	S <sub>1</sub>	W		dyn. C <sub>r</sub> N	stat. C <sub>0r</sub> N	
					mm	inch			
48	95	M14	42,9	25,4	–	5/32	27 500	15 300	770
48	95	M14	42,9	25,4	–	5/32	27 500	15 300	770
48	95	M14	42,9	25,4	–	5/32	27 500	15 300	770
48	95	M14	42,9	25,4	4	–	27 500	15 300	770
48	95	M14	42,9	25,4	–	5/32	27 500	15 300	770
54	100	M14	49,2	30,2	–	5/32	34 500	19 800	1010
54	100	M14	49,2	30,2	–	5/32	34 500	19 800	1010
54	100	M14	49,2	30,2	4	–	34 500	19 800	1010
54	108	M14	49,2	30,2	–	5/32	34 500	20 400	1030
54	108	M14	49,2	30,2	–	5/32	34 500	20 400	1030
54	108	M14	49,2	30,2	–	5/32	34 500	20 400	1030
54	108	M14	49,2	30,2	4	–	34 500	20 400	1030
60	116	M16	51,6	32,6	–	3/16	37 500	23 200	1180
60	116	M16	51,6	32,6	–	3/16	37 500	23 200	1180
60	116	M16	51,6	32,6	–	3/16	37 500	23 200	1180
60	116	M16	51,6	32,6	5	–	37 500	23 200	1180
60	116	M16	51,6	32,6	–	3/16	37 500	23 200	1180



# Two-bolt flanged housing units

Oval version

With grub screws in inner ring

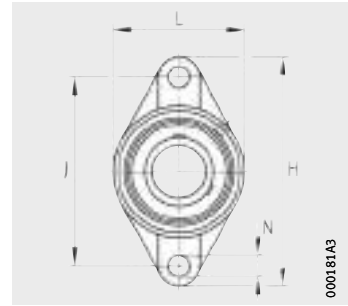

UCFL

**Dimension table** - Dimensions in mm and inch

Designation			Mass m ≈ kg	Dimensions				
Unit	Housing	Radial insert ball bearing		d		H	J	L
				mm	inch			
<b>UCFL201</b>	FL204	UC201	0,47	<b>12</b>	–	113	90	60
<b>UCFL201-08</b>	FL204	UC201-08	0,47	<b>12,7</b>	$1/2$	113	90	60
<b>UCFL202-09</b>	FL204	UC202-09	0,46	<b>14,288</b>	$9/16$	113	90	60
<b>UCFL202</b>	FL204	UC202	0,46	<b>15</b>	–	113	90	60
<b>UCFL202-10</b>	FL204	UC202-10	0,45	<b>15,875</b>	$5/8$	113	90	60
<b>UCFL203</b>	FL204	UC203	0,44	<b>17</b>	–	113	90	60
<b>UCFL203-11</b>	FL204	UC203-11	0,44	<b>17,463</b>	$11/16$	113	90	60
<b>UCFL204-12</b>	FL204	UC204-12	0,43	<b>19,05</b>	$3/4$	113	90	60
<b>UCFL204</b>	FL204	UC204	0,42	<b>20</b>	–	113	90	60
<b>UCFL205-13</b>	FL205	UC205-13	0,68	<b>20,638</b>	$13/16$	130	99	68
<b>UCFL205-14</b>	FL205	UC205-14	0,67	<b>22,225</b>	$7/8$	130	99	68
<b>UCFL205-15</b>	FL205	UC205-15	0,65	<b>23,813</b>	$15/16$	130	99	68
<b>UCFL205</b>	FL205	UC205	0,64	<b>25</b>	–	130	99	68
<b>UCFL205-16</b>	FL205	UC205-16	0,64	<b>25,4</b>	<b>1</b>	130	99	68
<b>UCFL206-17</b>	FL206	UC206-17	0,92	<b>26,988</b>	$11/16$	148	117	80
<b>UCFL206-18</b>	FL206	UC206-18	0,9	<b>28,575</b>	$11/8$	148	117	80
<b>UCFL206</b>	FL206	UC206	0,88	<b>30</b>	–	148	117	80
<b>UCFL206-19</b>	FL206	UC206-19	0,88	<b>30,163</b>	$13/16$	148	117	80
<b>UCFL206-20</b>	FL206	UC206-20	0,85	<b>31,75</b>	$11/4$	148	117	80
<b>UCFL207-20</b>	FL207	UC207-20	1,27	<b>31,75</b>	$11/4$	161	130	90
<b>UCFL207-21</b>	FL207	UC207-21	1,24	<b>33,338</b>	$15/16$	161	130	90
<b>UCFL207-22</b>	FL207	UC207-22	1,21	<b>34,925</b>	$13/8$	161	130	90
<b>UCFL207</b>	FL207	UC207	1,21	<b>35</b>	–	161	130	90
<b>UCFL207-23</b>	FL207	UC207-23	1,18	<b>36,513</b>	$17/16$	161	130	90
<b>UCFL208-24</b>	FL208	UC208-24	1,53	<b>38,1</b>	$11/2$	175	144	100
<b>UCFL208-25</b>	FL208	UC208-25	1,49	<b>39,688</b>	$19/16$	175	144	100
<b>UCFL208</b>	FL208	UC208	1,48	<b>40</b>	–	175	144	100

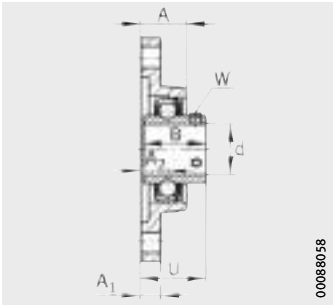

UCFL

						Width across flats		Load carrying capacity Bearing		
								Basic load ratings		Fatigue limit load $C_{ur}$ N
						A	$A_1$	$A_2$	N	
25,5	12	15	12	31	33,3	3	–	13 600	6 600	335
25,5	12	15	12	31	33,3	–	1/8	13 600	6 600	335
25,5	12	15	12	31	33,3	–	1/8	13 600	6 600	335
25,5	12	15	12	31	33,3	3	–	13 600	6 600	335
25,5	12	15	12	31	33,3	–	1/8	13 600	6 600	335
25,5	12	15	12	31	33,3	3	–	13 600	6 600	335
25,5	12	15	12	31	33,3	–	1/8	13 600	6 600	335
25,5	12	15	12	31	33,3	–	1/8	13 600	6 600	335
25,5	12	15	12	31	33,3	3	–	13 600	6 600	335
27	15	16	16	34,1	35,8	–	1/8	14 900	7 800	395
27	15	16	16	34,1	35,8	–	1/8	14 900	7 800	395
27	15	16	16	34,1	35,8	–	1/8	14 900	7 800	395
27	15	16	16	34,1	35,8	3	–	14 900	7 800	395
27	15	16	16	34,1	35,8	–	1/8	14 900	7 800	395
31	14	18	16	38,1	40,2	–	1/8	20 700	11 300	570
31	14	18	16	38,1	40,2	–	1/8	20 700	11 300	570
31	14	18	16	38,1	40,2	3	–	20 700	11 300	570
31	14	18	16	38,1	40,2	–	1/8	20 700	11 300	570
31	14	18	16	38,1	40,2	–	1/8	20 700	11 300	570
34	16	19	16	42,9	44,4	–	5/32	27 500	15 300	770
34	16	19	16	42,9	44,4	–	5/32	27 500	15 300	770
34	16	19	16	42,9	44,4	–	5/32	27 500	15 300	770
34	16	19	16	42,9	44,4	4	–	27 500	15 300	770
34	16	19	16	42,9	44,4	–	5/32	27 500	15 300	770
36	16	21	16	49,2	51,2	–	5/32	34 500	19 800	1010
36	16	21	16	49,2	51,2	–	5/32	34 500	19 800	1010
36	16	21	16	49,2	51,2	4	–	34 500	19 800	1010



# Two-bolt flanged housing units

Oval version

With grub screws in inner ring

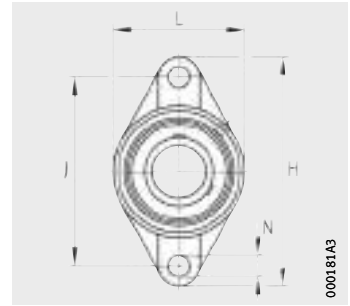

UCFL

**Dimension table** (continued) · Dimensions in mm and inch

Designation			Mass m ≈ kg	Dimensions				
Unit	Housing	Radial insert ball bearing		d		H	J	L
				mm	inch			
UCFL209-26	FL209	UC209-26	2,05	<b>41,275</b>	<b>1<sup>5</sup>/<sub>8</sub></b>	188	148	108
UCFL209-27	FL209	UC209-27	2,01	<b>42,863</b>	<b>1<sup>11</sup>/<sub>16</sub></b>	188	148	108
UCFL209-28	FL209	UC209-28	1,97	<b>44,45</b>	<b>1<sup>3</sup>/<sub>4</sub></b>	188	148	108
UCFL209	FL209	UC209	1,95	<b>45</b>	–	188	148	108
UCFL210-29	FL210	UC210-29	2,34	<b>46,038</b>	<b>1<sup>13</sup>/<sub>16</sub></b>	197	157	115
UCFL210-30	FL210	UC210-30	2,3	<b>47,625</b>	<b>1<sup>7</sup>/<sub>8</sub></b>	197	157	115
UCFL210-31	FL210	UC210-31	2,25	<b>49,213</b>	<b>1<sup>15</sup>/<sub>16</sub></b>	197	157	115
UCFL210	FL210	UC210	2,23	<b>50</b>	–	197	157	115
UCFL210-32	FL210	UC210-32	2,2	<b>50,8</b>	<b>2</b>	197	157	115
UCFL211-32	FL211	UC211-32	3,02	<b>50,8</b>	<b>2</b>	224	184	130
UCFL211-33	FL211	UC211-33	2,96	<b>52,388</b>	<b>2<sup>1</sup>/<sub>16</sub></b>	224	184	130
UCFL211-34	FL211	UC211-34	2,91	<b>53,975</b>	<b>2<sup>1</sup>/<sub>8</sub></b>	224	184	130
UCFL211	FL211	UC211	2,87	<b>55</b>	–	224	184	130
UCFL211-35	FL211	UC211-35	2,85	<b>55,563</b>	<b>2<sup>3</sup>/<sub>16</sub></b>	224	184	130
UCFL212-36	FL212	UC212-36	4,1	<b>57,15</b>	<b>2<sup>1</sup>/<sub>4</sub></b>	250	202	140
UCFL212-37	FL212	UC212-37	4,02	<b>58,738</b>	<b>2<sup>5</sup>/<sub>16</sub></b>	250	202	140
UCFL212	FL212	UC212	3,96	<b>60</b>	–	250	202	140
UCFL212-38	FL212	UC212-38	3,95	<b>60,325</b>	<b>2<sup>3</sup>/<sub>8</sub></b>	250	202	140
UCFL212-39	FL212	UC212-39	3,87	<b>61,913</b>	<b>2<sup>7</sup>/<sub>16</sub></b>	250	202	140
UCFL213-40	FL213	UC213-40	4,78	<b>63,5</b>	<b>2<sup>1</sup>/<sub>2</sub></b>	258	210	155
UCFL213	FL213	UC213	4,69	<b>65</b>	–	258	210	155
UCFL213-41	FL213	UC213-41	4,68	<b>65,088</b>	<b>2<sup>9</sup>/<sub>16</sub></b>	258	210	155

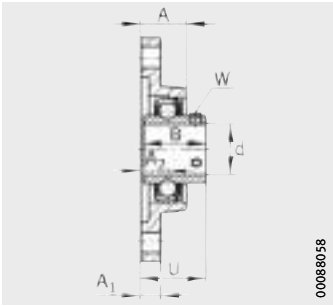

UCFL

						Width across flats		Load carrying capacity Bearing		
						W		Basic load ratings		Fatigue limit load
A	A <sub>1</sub>	A <sub>2</sub>	N	B	U			dyn. C <sub>r</sub>	stat. C <sub>0r</sub>	C <sub>ur</sub>
						mm	inch	N	N	N
38	18	22	19	49,2	52,2	–	5/32	34 500	20 400	1 030
38	18	22	19	49,2	52,2	–	5/32	34 500	20 400	1 030
38	18	22	19	49,2	52,2	–	5/32	34 500	20 400	1 030
38	18	22	19	49,2	52,2	4	–	34 500	20 400	1 030
40	18	22	19	51,6	54,6	–	3/16	37 500	23 200	1 180
40	18	22	19	51,6	54,6	–	3/16	37 500	23 200	1 180
40	18	22	19	51,6	54,6	–	3/16	37 500	23 200	1 180
40	18	22	19	51,6	54,6	5	–	37 500	23 200	1 180
40	18	22	19	51,6	54,6	–	3/16	37 500	23 200	1 180
43	20	25	19	55,6	58,4	–	3/16	46 000	29 000	1 480
43	20	25	19	55,6	58,4	–	3/16	46 000	29 000	1 480
43	20	25	19	55,6	58,4	–	3/16	46 000	29 000	1 480
43	20	25	19	55,6	58,4	5	–	46 000	29 000	1 480
43	20	25	19	55,6	58,4	–	3/16	46 000	29 000	1 480
48	20	29	23	65,1	68,7	–	3/16	56 000	36 000	1 820
48	20	29	23	65,1	68,7	–	3/16	56 000	36 000	1 820
48	20	29	23	65,1	68,7	5	–	56 000	36 000	1 820
48	20	29	23	65,1	68,7	–	3/16	56 000	36 000	1 820
48	20	29	23	65,1	68,7	–	3/16	56 000	36 000	1 820
50	24	30	23	65,1	69,7	–	1/4	61 000	40 000	2 030
50	24	30	23	65,1	69,7	6	–	61 000	40 000	2 030
50	24	30	23	65,1	69,7	–	1/4	61 000	40 000	2 030



# Two-bolt flanged housing units

Oval version

With grub screws in inner ring

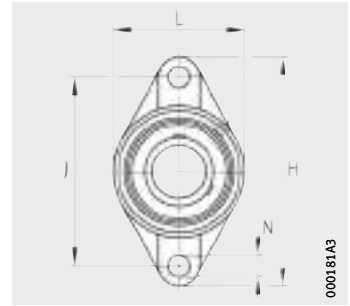

UCFL

**Dimension table** (continued) · Dimensions in mm and inch

Designation			Mass m ≈ kg	Dimensions				
Unit	Housing	Radial insert ball bearing		d		H	J	L
				mm	inch			
<b>UCFL214-42</b>	FL214	UC214-42	5,45	<b>66,675</b>	<b>2<sup>5</sup>/<sub>8</sub></b>	265	216	160
<b>UCFL214-43</b>	FL214	UC214-43	5,35	<b>68,263</b>	<b>2<sup>11</sup>/<sub>16</sub></b>	265	216	160
<b>UCFL214-44</b>	FL214	UC214-44	5,25	<b>69,85</b>	<b>2<sup>3</sup>/<sub>4</sub></b>	265	216	160
<b>UCFL214</b>	FL214	UC214	5,25	<b>70</b>	–	265	216	160
<b>UCFL215-45</b>	FL215	UC215-45	5,94	<b>71,438</b>	<b>2<sup>13</sup>/<sub>16</sub></b>	275	225	165
<b>UCFL215-46</b>	FL215	UC215-46	5,82	<b>73,025</b>	<b>2<sup>7</sup>/<sub>8</sub></b>	275	225	165
<b>UCFL215-47</b>	FL215	UC215-47	5,72	<b>74,613</b>	<b>2<sup>15</sup>/<sub>16</sub></b>	275	225	165
<b>UCFL215</b>	FL215	UC215	5,69	<b>75</b>	–	275	225	165
<b>UCFL215-48</b>	FL215	UC215-48	5,61	<b>76,2</b>	<b>3</b>	275	225	165
<b>UCFL216-49</b>	FL216	UC216-49	7,41	<b>77,788</b>	<b>3<sup>1</sup>/<sub>16</sub></b>	290	233	180
<b>UCFL216-50</b>	FL216	UC216-50	7,29	<b>79,375</b>	<b>3<sup>1</sup>/<sub>8</sub></b>	290	233	180
<b>UCFL216</b>	FL216	UC216	7,24	<b>80</b>	–	290	233	180
<b>UCFL216-51</b>	FL216	UC216-51	7,16	<b>80,963</b>	<b>3<sup>3</sup>/<sub>16</sub></b>	290	233	180
<b>UCFL217-52</b>	FL217	UC217-52	9,01	<b>82,55</b>	<b>3<sup>1</sup>/<sub>4</sub></b>	305	248	190
<b>UCFL217-53</b>	FL217	UC217-53	8,85	<b>84,138</b>	<b>3<sup>5</sup>/<sub>16</sub></b>	305	248	190
<b>UCFL217</b>	FL217	UC217	8,77	<b>85</b>	–	305	248	190
<b>UCFL217-55</b>	FL217	UC217-55	8,54	<b>87,313</b>	<b>3<sup>7</sup>/<sub>16</sub></b>	305	248	190
<b>UCFL218-56</b>	FL218	UC218-56	10,51	<b>88,9</b>	<b>3<sup>1</sup>/<sub>2</sub></b>	320	265	205
<b>UCFL218</b>	FL218	UC218	10,4	<b>90</b>	–	320	265	205



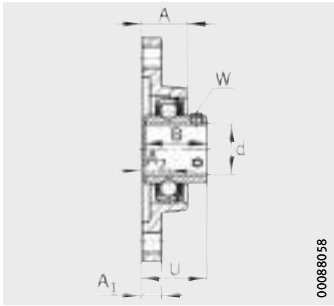

UCFL

						Width across flats		Load carrying capacity Bearing		
								Basic load ratings		Fatigue limit load
A	A <sub>1</sub>	A <sub>2</sub>	N	B	U	W		dyn. C <sub>r</sub> N	stat. C <sub>0r</sub> N	C <sub>ur</sub> N
						mm	inch			
54	24	31	23	74,6	75,4	–	1/4	66 000	44 000	2 230
54	24	31	23	74,6	75,4	–	1/4	66 000	44 000	2 230
54	24	31	23	74,6	75,4	–	1/4	66 000	44 000	2 230
54	24	31	23	74,6	75,4	6	–	66 000	44 000	2 230
56	24	34	23	77,8	78,5	–	1/4	66 000	44 500	2 240
56	24	34	23	77,8	78,5	–	1/4	66 000	44 500	2 240
56	24	34	23	77,8	78,5	–	1/4	66 000	44 500	2 240
56	24	34	23	77,8	78,5	6	–	66 000	44 500	2 240
56	24	34	23	77,8	78,5	–	1/4	66 000	44 500	2 240
58	24	34	25	82,6	83,3	–	1/4	76 000	54 000	2 600
58	24	34	25	82,6	83,3	–	1/4	76 000	54 000	2 600
58	24	34	25	82,6	83,3	6	–	76 000	54 000	2 600
58	24	34	25	82,6	83,3	–	1/4	76 000	54 000	2 600
63	26	36	25	85,7	87,6	–	1/4	88 000	64 000	2 950
63	26	36	25	85,7	87,6	–	1/4	88 000	64 000	2 950
63	26	36	25	85,7	87,6	6	–	88 000	64 000	2 950
63	26	36	25	85,7	87,6	–	1/4	88 000	64 000	2 950
68	26	40	25	96	96,3	–	1/4	102 000	72 000	3 250
68	26	40	25	96	96,3	6	–	102 000	72 000	3 250



# Two-bolt flanged housing units

Oval version  
With adapter sleeve

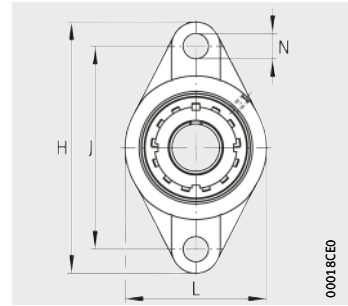

UKFL

**Dimension table** - Dimensions in mm

Designation			Mass	Dimensions			
Unit	Housing	Radial insert ball bearing		d	H	J	L
			m				
			≈ kg				
<b>UKFL205</b>	FL205	UK205	0,69	<b>20</b>	130	99	68
<b>UKFL206</b>	FL206	UK206	0,94	<b>25</b>	148	117	80
<b>UKFL207</b>	FL207	UK207	1,29	<b>30</b>	161	130	90
<b>UKFL208</b>	FL208	UK208	1,56	<b>35</b>	175	144	100
<b>UKFL209</b>	FL209	UK209	2,08	<b>40</b>	188	148	108
<b>UKFL210</b>	FL210	UK210	2,4	<b>45</b>	197	157	115
<b>UKFL211</b>	FL211	UK211	3,04	<b>50</b>	224	184	130
<b>UKFL212</b>	FL212	UK212	4,05	<b>55</b>	250	202	140
<b>UKFL213</b>	FL213	UK213	4,84	<b>60</b>	258	210	155
<b>UKFL215</b>	FL215	UK215	6,14	<b>65</b>	275	225	165
<b>UKFL216</b>	FL216	UK216	7,74	<b>70</b>	290	233	180
<b>UKFL217</b>	FL217	UK217	9,02	<b>75</b>	305	248	190
<b>UKFL218</b>	FL218	UK218	10,91	<b>80</b>	320	265	205

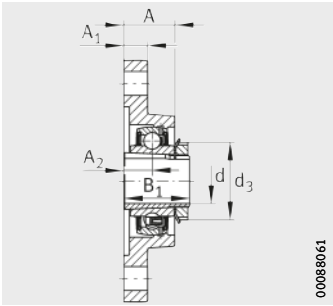

UKFL

						Load carrying capacity		
						Bearing		Fatigue limit load
						Basic load ratings		
A	A <sub>1</sub>	A <sub>2</sub>	N	B <sub>1</sub>	d <sub>3</sub> max.	dyn. C <sub>r</sub> N	stat. C <sub>0r</sub> N	C <sub>ur</sub> N
27	15	16	16	35	38	14 900	7 800	395
31	14	18	16	38	45	20 700	11 300	570
34	16	19	16	43	52	27 500	15 300	770
36	16	21	16	46	58	34 500	19 800	1 010
38	18	22	19	50	65	34 500	20 400	1 030
40	18	22	19	55	70	37 500	23 200	1 180
43	20	25	19	59	75	46 000	29 000	1 480
48	20	29	23	62	80	56 000	36 000	1 820
50	24	30	23	65	85	61 000	40 000	2 030
56	24	34	23	73	98	66 000	44 500	2 240
58	24	34	25	78	105	76 000	54 000	2 600
63	26	36	25	82	110	88 000	64 000	2 950
68	26	40	25	86	120	102 000	72 000	3 250



# Four-bolt flanged housing units

Square version

With grub screws in inner ring

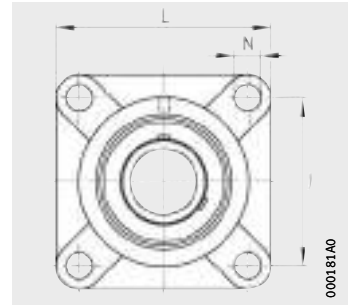

UCF

**Dimension table** - Dimensions in mm and inch

Designation			Mass  m  ≈ kg	Dimensions				
Unit	Housing	Radial insert ball bearing		d		J	L	A
				mm	inch			
UCF201	F204	UC201	0,62	12	–	64	86	25,5
UCF201-08	F204	UC201-08	0,62	12,7	1/2	64	86	25,5
UCF202-09	F204	UC202-09	0,61	14,288	9/16	64	86	25,5
UCF202	F204	UC202	0,6	15	–	64	86	25,5
UCF202-10	F204	UC202-10	0,6	15,875	5/8	64	86	25,5
UCF203	F204	UC203	0,59	17	–	64	86	25,5
UCF203-11	F204	UC203-11	0,59	17,463	11/16	64	86	25,5
UCF204-12	F204	UC204-12	0,58	19,05	3/4	64	86	25,5
UCF204	F204	UC204	0,57	20	–	64	86	25,5
UCF205-13	F205	UC205-13	0,89	20,638	13/16	70	95	27
UCF205-14	F205	UC205-14	0,87	22,225	7/8	70	95	27
UCF205-15	F205	UC205-15	0,86	23,813	15/16	70	95	27
UCF205	F205	UC205	0,85	25	–	70	95	27
UCF205-16	F205	UC205-16	0,84	25,4	1	70	95	27
UCF206-17	F206	UC206-17	1,15	26,988	11/16	83	108	31
UCF206-18	F206	UC206-18	1,13	28,575	11/8	83	108	31
UCF206	F206	UC206	1,11	30	–	83	108	31
UCF206-19	F206	UC206-19	1,11	30,163	13/16	83	108	31
UCF206-20	F206	UC206-20	1,09	31,75	11/4	83	108	31
UCF207-20	F207	UC207-20	1,55	31,75	11/4	92	117	34
UCF207-21	F207	UC207-21	1,53	33,338	15/16	92	117	34
UCF207-22	F207	UC207-22	1,5	34,925	13/8	92	117	34
UCF207	F207	UC207	1,5	35	–	92	117	34
UCF207-23	F207	UC207-23	1,47	36,513	17/16	92	117	34
UCF208-24	F208	UC208-24	1,95	38,1	11/2	102	130	36
UCF208-25	F208	UC208-25	1,92	39,688	19/16	102	130	36
UCF208	F208	UC208	1,91	40	–	102	130	36

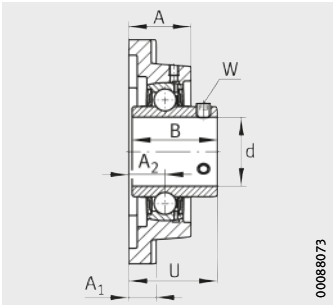

UCF

UCF					Width across flats		Load carrying capacity Bearing		
							Basic load ratings		Fatigue limit load $C_{ur}$ N
					$A_1$	$A_2$	N	B	
									mm
12	15	12	31	33,3	3	–	13 600	6 600	335
12	15	12	31	33,3	–	1/8	13 600	6 600	335
12	15	12	31	33,3	–	1/8	13 600	6 600	335
12	15	12	31	33,3	3	–	13 600	6 600	335
12	15	12	31	33,3	–	1/8	13 600	6 600	335
12	15	12	31	33,3	3	–	13 600	6 600	335
12	15	12	31	33,3	–	1/8	13 600	6 600	335
12	15	12	31	33,3	–	1/8	13 600	6 600	335
12	15	12	31	33,3	3	–	13 600	6 600	335
14	16	12	34,1	35,8	–	1/8	14 900	7 800	395
14	16	12	34,1	35,8	–	1/8	14 900	7 800	395
14	16	12	34,1	35,8	–	1/8	14 900	7 800	395
14	16	12	34,1	35,8	3	–	14 900	7 800	395
14	16	12	34,1	35,8	–	1/8	14 900	7 800	395
14	18	12	38,1	40,2	–	1/8	20 700	11 300	570
14	18	12	38,1	40,2	–	1/8	20 700	11 300	570
14	18	12	38,1	40,2	3	–	20 700	11 300	570
14	18	12	38,1	40,2	–	1/8	20 700	11 300	570
14	18	12	38,1	40,2	–	1/8	20 700	11 300	570
16	19	14	42,9	44,4	–	5/32	27 500	15 300	770
16	19	14	42,9	44,4	–	5/32	27 500	15 300	770
16	19	14	42,9	44,4	–	5/32	27 500	15 300	770
16	19	14	42,9	44,4	4	–	27 500	15 300	770
16	19	14	42,9	44,4	–	5/32	27 500	15 300	770
16	21	16	49,2	51,2	–	5/32	34 500	19 800	1 010
16	21	16	49,2	51,2	–	5/32	34 500	19 800	1 010
16	21	16	49,2	51,2	4	–	34 500	19 800	1 010



# Four-bolt flanged housing units

Square version  
With grub screws in inner ring

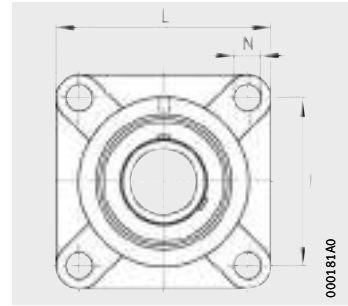

UCF

**Dimension table** (continued) · Dimensions in mm and inch

Designation			Mass m ≈ kg	Dimensions				
Unit	Housing	Radial insert ball bearing		d		J	L	A
				mm	inch			
UCF209-26	F209	UC209-26	2,4	41,275	1 <sup>5</sup> / <sub>8</sub>	105	137	38
UCF209-27	F209	UC209-27	2,36	42,863	1 <sup>11</sup> / <sub>16</sub>	105	137	38
UCF209-28	F209	UC209-28	2,32	44,45	1 <sup>3</sup> / <sub>4</sub>	105	137	38
UCF209	F209	UC209	2,3	45	–	105	137	38
UCF210-29	F210	UC210-29	2,67	46,038	1 <sup>13</sup> / <sub>16</sub>	111	143	40
UCF210-30	F210	UC210-30	2,63	47,625	1 <sup>7</sup> / <sub>8</sub>	111	143	40
UCF210-31	F210	UC210-31	2,58	49,213	1 <sup>15</sup> / <sub>16</sub>	111	143	40
UCF210	F210	UC210	2,56	50	–	111	143	40
UCF210-32	F210	UC210-32	2,53	50,8	2	111	143	40
UCF211-32	F211	UC211-32	3,46	50,8	2	130	163	43
UCF211-33	F211	UC211-33	3,4	52,388	2 <sup>1</sup> / <sub>16</sub>	130	163	43
UCF211-34	F211	UC211-34	3,35	53,975	2 <sup>1</sup> / <sub>8</sub>	130	163	43
UCF211	F211	UC211	3,31	55	–	130	163	43
UCF211-35	F211	UC211-35	3,29	55,563	2 <sup>3</sup> / <sub>16</sub>	130	163	43
UCF212-36	F212	UC212-36	4,38	57,15	2 <sup>1</sup> / <sub>4</sub>	143	175	48
UCF212-37	F212	UC212-37	4,31	58,738	2 <sup>5</sup> / <sub>16</sub>	143	175	48
UCF212	F212	UC212	4,25	60	–	143	175	48
UCF212-38	F212	UC212-38	4,23	60,325	2 <sup>3</sup> / <sub>8</sub>	143	175	48
UCF212-39	F212	UC212-39	4,15	61,913	2 <sup>7</sup> / <sub>16</sub>	143	175	48
UCF213-40	F213	UC213-40	4,98	63,5	2 <sup>1</sup> / <sub>2</sub>	149	187	50
UCF213	F213	UC213	4,9	65	–	149	187	50
UCF213-41	F213	UC213-41	4,9	65,088	2 <sup>9</sup> / <sub>16</sub>	149	187	50
UCF214-42	F214	UC214-42	6,19	66,675	2 <sup>5</sup> / <sub>8</sub>	152	193	54
UCF214-43	F214	UC214-43	6,09	68,263	2 <sup>11</sup> / <sub>16</sub>	152	193	54
UCF214-44	F214	UC214-44	5,99	69,85	2 <sup>3</sup> / <sub>4</sub>	152	193	54
UCF214	F214	UC214	5,99	70	–	152	193	54

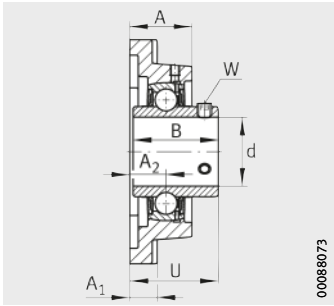

UCF

					Width across flats		Load carrying capacity Bearing		
					W		Basic load ratings		Fatigue limit load
A <sub>1</sub>	A <sub>2</sub>	N	B	U			dyn. C <sub>r</sub>	stat. C <sub>0r</sub>	C <sub>ur</sub>
					mm	inch	N	N	N
18	22	16	49,2	52,2	–	5/32	34 500	20 400	1 030
18	22	16	49,2	52,2	–	5/32	34 500	20 400	1 030
18	22	16	49,2	52,2	–	5/32	34 500	20 400	1 030
18	22	16	49,2	52,2	4	–	34 500	20 400	1 030
18	22	16	51,6	54,6	–	3/16	37 500	23 200	1 180
18	22	16	51,6	54,6	–	3/16	37 500	23 200	1 180
18	22	16	51,6	54,6	–	3/16	37 500	23 200	1 180
18	22	16	51,6	54,6	5	–	37 500	23 200	1 180
18	22	16	51,6	54,6	–	3/16	37 500	23 200	1 180
20	25	19	55,6	58,4	–	3/16	46 000	29 000	1 480
20	25	19	55,6	58,4	–	3/16	46 000	29 000	1 480
20	25	19	55,6	58,4	–	3/16	46 000	29 000	1 480
20	25	19	55,6	58,4	5	–	46 000	29 000	1 480
20	25	19	55,6	58,4	–	3/16	46 000	29 000	1 480
20	29	19	65,1	68,7	–	3/16	56 000	36 000	1 820
20	29	19	65,1	68,7	–	3/16	56 000	36 000	1 820
20	29	19	65,1	68,7	5	–	56 000	36 000	1 820
20	29	19	65,1	68,7	–	3/16	56 000	36 000	1 820
20	29	19	65,1	68,7	–	3/16	56 000	36 000	1 820
20	30	19	65,1	69,7	–	1/4	61 000	40 000	2 030
20	30	19	65,1	69,7	6	–	61 000	40 000	2 030
20	30	19	65,1	69,7	–	1/4	61 000	40 000	2 030
24	31	19	74,6	75,4	–	1/4	66 000	44 000	2 230
24	31	19	74,6	75,4	–	1/4	66 000	44 000	2 230
24	31	19	74,6	75,4	–	1/4	66 000	44 000	2 230
24	31	19	74,6	75,4	6	–	66 000	44 000	2 230



# Four-bolt flanged housing units

Square version

With grub screws in inner ring

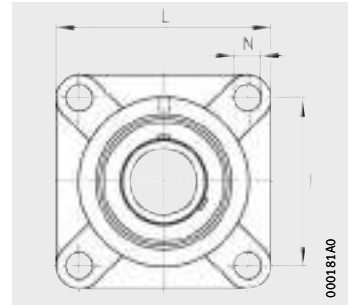

UCF

**Dimension table** (continued) · Dimensions in mm and inch

Designation			Mass m ≈ kg	Dimensions				
Unit	Housing	Radial insert ball bearing		d		J	L	A
				mm	inch			
<b>UCF215-45</b>	F215	UC215-45	6,9	<b>71,438</b>	<b>2<sup>13</sup>/<sub>16</sub></b>	159	200	56
<b>UCF215-46</b>	F215	UC215-46	6,8	<b>73,025</b>	<b>2<sup>7</sup>/<sub>8</sub></b>	159	200	56
<b>UCF215-47</b>	F215	UC215-47	6,7	<b>74,613</b>	<b>2<sup>15</sup>/<sub>16</sub></b>	159	200	56
<b>UCF215</b>	F215	UC215	6,7	<b>75</b>	–	159	200	56
<b>UCF215-48</b>	F215	UC215-48	6,6	<b>76,2</b>	<b>3</b>	159	200	56
<b>UCF216-49</b>	F216	UC216-49	7,6	<b>77,788</b>	<b>3<sup>1</sup>/<sub>16</sub></b>	165	208	58
<b>UCF216-50</b>	F216	UC216-50	7,5	<b>79,375</b>	<b>3<sup>1</sup>/<sub>8</sub></b>	165	208	58
<b>UCF216</b>	F216	UC216	7,4	<b>80</b>	–	165	208	58
<b>UCF216-51</b>	F216	UC216-51	7,3	<b>80,963</b>	<b>3<sup>3</sup>/<sub>16</sub></b>	165	208	58
<b>UCF217-52</b>	F217	UC217-52	9,3	<b>82,55</b>	<b>3<sup>1</sup>/<sub>4</sub></b>	175	220	63
<b>UCF217-53</b>	F217	UC217-53	9,1	<b>84,138</b>	<b>3<sup>5</sup>/<sub>16</sub></b>	175	220	63
<b>UCF217</b>	F217	UC217	9,1	<b>85</b>	–	175	220	63
<b>UCF217-55</b>	F217	UC217-55	8,8	<b>87,313</b>	<b>3<sup>7</sup>/<sub>16</sub></b>	175	220	63
<b>UCF218-56</b>	F218	UC218-56	10,8	<b>88,9</b>	<b>3<sup>1</sup>/<sub>2</sub></b>	187	235	68
<b>UCF218</b>	F218	UC218	10,7	<b>90</b>	–	187	235	68



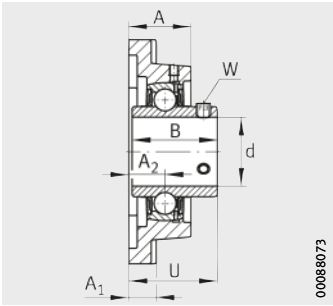

UCF

UCF					Width across flats		Load carrying capacity Bearing		
							Basic load ratings		Fatigue limit load $C_{ur}$ N
					$A_1$	$A_2$	N	B	
24	34	19	77,8	78,5	–	1/4	66 000	44 500	2 240
24	34	19	77,8	78,5	–	1/4	66 000	44 500	2 240
24	34	19	77,8	78,5	–	1/4	66 000	44 500	2 240
24	34	19	77,8	78,5	6	–	66 000	44 500	2 240
24	34	19	77,8	78,5	–	1/4	66 000	44 500	2 240
24	34	23	82,6	83,3	–	1/4	76 000	54 000	2 600
24	34	23	82,6	83,3	–	1/4	76 000	54 000	2 600
24	34	23	82,6	83,3	6	–	76 000	54 000	2 600
24	34	23	82,6	83,3	–	1/4	76 000	54 000	2 600
26	36	23	85,7	87,6	–	1/4	88 000	64 000	2 950
26	36	23	85,7	87,6	–	1/4	88 000	64 000	2 950
26	36	23	85,7	87,6	6	–	88 000	64 000	2 950
26	36	23	85,7	87,6	–	1/4	88 000	64 000	2 950
26	40	23	96	96,3	–	1/4	102 000	72 000	3 250
26	40	23	96	96,3	6	–	102 000	72 000	3 250



# Four-bolt flanged housing units

Square version  
With adapter sleeve

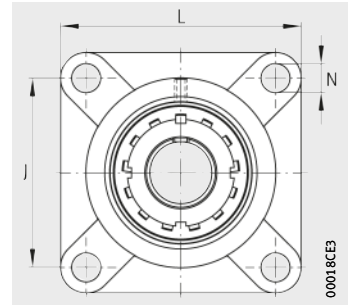

UKF

**Dimension table** - Dimensions in mm

Designation			Mass	Dimensions			
Unit	Housing	Radial insert ball bearing		d	J	L	A
			m				
			≈ kg				
<b>UKF205</b>	F205	UK205	0,9	<b>20</b>	70	95	27
<b>UKF206</b>	F206	UK206	1,18	<b>25</b>	83	108	31
<b>UKF207</b>	F207	UK207	1,58	<b>30</b>	92	117	34
<b>UKF208</b>	F208	UK208	1,99	<b>35</b>	102	130	36
<b>UKF209</b>	F209	UK209	2,44	<b>40</b>	105	137	38
<b>UKF210</b>	F210	UK210	2,73	<b>45</b>	111	143	40
<b>UKF211</b>	F211	UK211	3,48	<b>50</b>	130	163	43
<b>UKF212</b>	F212	UK212	4,34	<b>55</b>	143	175	48
<b>UKF213</b>	F213	UK213	5,06	<b>60</b>	149	187	50
<b>UKF215</b>	F215	UK215	7,13	<b>65</b>	159	200	56
<b>UKF216</b>	F216	UK216	7,9	<b>70</b>	165	208	58
<b>UKF217</b>	F217	UK217	9,55	<b>75</b>	175	220	63
<b>UKF218</b>	F218	UK218	11,16	<b>80</b>	187	235	68

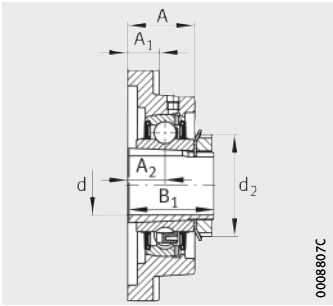

0008807C

UKF

					Load carrying capacity Bearing		
					Basic load ratings		Fatigue limit load $C_{ur}$ N
$A_1$	$A_2$	N	$B_1$	$d_2$ max.	dyn. $C_r$ N	stat. $C_{0r}$ N	
14	16	12	35	38	14 900	7 800	395
14	18	12	38	45	20 700	11 300	570
16	19	14	43	52	27 500	15 300	770
16	21	16	46	58	34 500	19 800	1 010
18	22	16	50	65	34 500	20 400	1 030
18	22	16	55	70	37 500	23 200	1 180
20	25	19	59	75	46 000	29 000	1 480
20	29	19	62	80	56 000	36 000	1 820
20	30	19	65	85	61 000	40 000	2 030
24	34	19	73	98	66 000	44 500	2 240
24	34	23	78	105	76 000	54 000	2 600
26	36	23	82	110	88 000	64 000	2 950
26	40	23	86	120	102 000	72 000	3 250



# Four-bolt flanged housing units

Round version  
With grub screws in inner ring

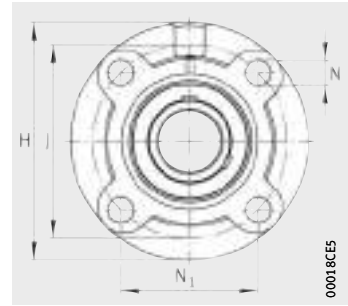

UCFC

**Dimension table** - Dimensions in mm and inch

Designation			Mass m ≈ kg	Dimensions						
Unit	Housing	Radial insert ball bearing		d		H	J	A	A <sub>1</sub>	A <sub>2</sub>
				mm	inch					
UCFC201	FC204	UC201	0,77	12	–	100	78	20,5	8	10
UCFC201-08	FC204	UC201-08	0,77	12,7	1/2	100	78	20,5	8	10
UCFC202-09	FC204	UC202-09	0,76	14,288	9/16	100	78	20,5	8	10
UCFC202	FC204	UC202	0,76	15	–	100	78	20,5	8	10
UCFC202-10	FC204	UC202-10	0,75	15,875	5/8	100	78	20,5	8	10
UCFC203	FC204	UC203	0,74	17	–	100	78	20,5	8	10
UCFC203-11	FC204	UC203-11	0,74	17,463	11/16	100	78	20,5	8	10
UCFC204-12	FC204	UC204-12	0,73	19,05	3/4	100	78	20,5	8	10
UCFC204	FC204	UC204	0,72	20	–	100	78	20,5	8	10
UCFC205-13	FC205	UC205-13	0,98	20,638	13/16	115	90	21	7	10
UCFC205-14	FC205	UC205-14	0,97	22,225	7/8	115	90	21	7	10
UCFC205-15	FC205	UC205-15	0,95	23,813	15/16	115	90	21	7	10
UCFC205	FC205	UC205	0,94	25	–	115	90	21	7	10
UCFC205-16	FC205	UC205-16	0,94	25,4	1	115	90	21	7	10
UCFC206-17	FC206	UC206-17	1,29	26,988	11/16	125	100	23	8	10
UCFC206-18	FC206	UC206-18	1,27	28,575	11/8	125	100	23	8	10
UCFC206	FC206	UC206	1,25	30	–	125	100	23	8	10
UCFC206-19	FC206	UC206-19	1,25	30,163	13/16	125	100	23	8	10
UCFC206-20	FC206	UC206-20	1,23	31,75	11/4	125	100	23	8	10
UCFC207-20	FC207	UC207-20	1,76	31,75	11/4	135	110	26	9	11
UCFC207-21	FC207	UC207-21	1,73	33,338	15/16	135	110	26	9	11
UCFC207-22	FC207	UC207-22	1,7	34,925	13/8	135	110	26	9	11
UCFC207	FC207	UC207	1,7	35	–	135	110	26	9	11
UCFC207-23	FC207	UC207-23	1,67	36,513	17/16	135	110	26	9	11

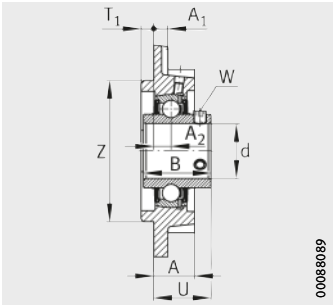

00088089

UCFC

N	N <sub>1</sub>	B	T <sub>1</sub>	U	Z	Width across flats		Load carrying capacity Bearing		
						W		Basic load ratings		Fatigue limit load C <sub>ur</sub> N
						mm	inch	dyn. C <sub>r</sub> N	stat. C <sub>0r</sub> N	
12	55,1	31	5	28,3	62	3	–	13 600	6 600	335
12	55,1	31	5	28,3	62	–	1/8	13 600	6 600	335
12	55,1	31	5	28,3	62	–	1/8	13 600	6 600	335
12	55,1	31	5	28,3	62	3	–	13 600	6 600	335
12	55,1	31	5	28,3	62	–	1/8	13 600	6 600	335
12	55,1	31	5	28,3	62	3	–	13 600	6 600	335
12	55,1	31	5	28,3	62	–	1/8	13 600	6 600	335
12	55,1	31	5	28,3	62	–	1/8	13 600	6 600	335
12	55,1	31	5	28,3	62	3	–	13 600	6 600	335
12	63,6	34,1	6	29,8	70	–	1/8	14 900	7 800	395
12	63,6	34,1	6	29,8	70	–	1/8	14 900	7 800	395
12	63,6	34,1	6	29,8	70	–	1/8	14 900	7 800	395
12	63,6	34,1	6	29,8	70	3	–	14 900	7 800	395
12	63,6	34,1	6	29,8	70	–	1/8	14 900	7 800	395
12	70,7	38,1	8	32,2	80	–	1/8	20 700	11 300	570
12	70,7	38,1	8	32,2	80	–	1/8	20 700	11 300	570
12	70,7	38,1	8	32,2	80	3	–	20 700	11 300	570
12	70,7	38,1	8	32,2	80	–	1/8	20 700	11 300	570
12	70,7	38,1	8	32,2	80	–	1/8	20 700	11 300	570
14	77,8	42,9	8	36,4	90	–	5/32	27 500	15 300	770
14	77,8	42,9	8	36,4	90	–	5/32	27 500	15 300	770
14	77,8	42,9	8	36,4	90	–	5/32	27 500	15 300	770
14	77,8	42,9	8	36,4	90	4	–	27 500	15 300	770
14	77,8	42,9	8	36,4	90	–	5/32	27 500	15 300	770



# Four-bolt flanged housing units

Round version

With grub screws in inner ring

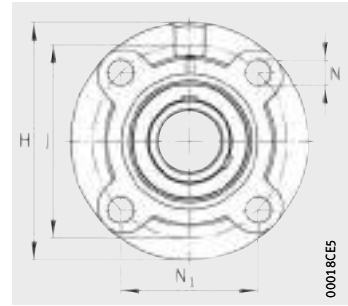

UCFC

**Dimension table** (continued) · Dimensions in mm and inch

Designation			Mass m ≈ kg	Dimensions						
Unit	Housing	Radial insert ball bearing		d		H	J	A	A <sub>1</sub>	A <sub>2</sub>
				mm	inch					
UCFC208-24	FC208	UC208-24	2,08	<b>38,1</b>	<b>1 1/2</b>	145	120	26	9	11
UCFC208-25	FC208	UC208-25	2,04	<b>39,688</b>	<b>1 9/16</b>	145	120	26	9	11
UCFC208	FC208	UC208	2,03	<b>40</b>	–	145	120	26	9	11
UCFC209-26	FC209	UC209-26	2,78	<b>41,275</b>	<b>1 5/8</b>	160	132	26	14	10
UCFC209-27	FC209	UC209-27	2,74	<b>42,863</b>	<b>1 11/16</b>	160	132	26	14	10
UCFC209-28	FC209	UC209-28	2,7	<b>44,45</b>	<b>1 3/4</b>	160	132	26	14	10
UCFC209	FC209	UC209	2,69	<b>45</b>	–	160	132	26	14	10
UCFC210-29	FC210	UC210-29	3,08	<b>46,038</b>	<b>1 13/16</b>	165	138	28	14	10
UCFC210-30	FC210	UC210-30	3,03	<b>47,625</b>	<b>1 7/8</b>	165	138	28	14	10
UCFC210-31	FC210	UC210-31	2,98	<b>49,213</b>	<b>1 15/16</b>	165	138	28	14	10
UCFC210	FC210	UC210	2,96	<b>50</b>	–	165	138	28	14	10
UCFC210-32	FC210	UC210-32	2,94	<b>50,8</b>	<b>2</b>	165	138	28	14	10
UCFC211-32	FC211	UC211-32	4,13	<b>50,8</b>	<b>2</b>	185	150	31	15	13
UCFC211-33	FC211	UC211-33	4,07	<b>52,388</b>	<b>2 1/16</b>	185	150	31	15	13
UCFC211-34	FC211	UC211-34	4,02	<b>53,975</b>	<b>2 1/8</b>	185	150	31	15	13
UCFC211	FC211	UC211	3,98	<b>55</b>	–	185	150	31	15	13
UCFC211-35	FC211	UC211-35	3,96	<b>55,563</b>	<b>2 3/16</b>	185	150	31	15	13
UCFC212-36	FC212	UC212-36	5	<b>57,15</b>	<b>2 1/4</b>	195	160	36	15	17
UCFC212-37	FC212	UC212-37	4,92	<b>58,738</b>	<b>2 5/16</b>	195	160	36	15	17
UCFC212	FC212	UC212	4,86	<b>60</b>	–	195	160	36	15	17
UCFC212-38	FC212	UC212-38	4,85	<b>60,325</b>	<b>2 3/8</b>	195	160	36	15	17
UCFC212-39	FC212	UC212-39	4,77	<b>61,913</b>	<b>2 7/16</b>	195	160	36	15	17

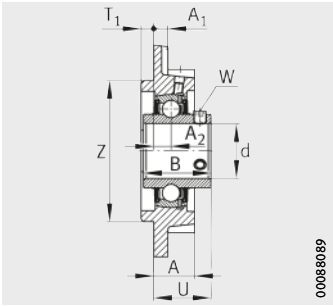

UCFC

00085089

N	N <sub>1</sub>	B	T <sub>1</sub>	U	Z	Width across flats		Load carrying capacity Bearing		
						W	h8	Basic load ratings		Fatigue limit load C <sub>ur</sub> N
								dyn. C <sub>r</sub> N	stat. C <sub>0r</sub> N	
14	84,8	49,2	10	41,2	100	–	5/32	34 500	19 800	1 010
14	84,8	49,2	10	41,2	100	–	5/32	34 500	19 800	1 010
14	84,8	49,2	10	41,2	100	4	–	34 500	19 800	1 010
16	93,3	49,2	12	40,2	105	–	5/32	34 500	20 400	1 030
16	93,3	49,2	12	40,2	105	–	5/32	34 500	20 400	1 030
16	93,3	49,2	12	40,2	105	–	5/32	34 500	20 400	1 030
16	93,3	49,2	12	40,2	105	4	–	34 500	20 400	1 030
16	97,6	51,6	12	42,6	110	–	3/16	37 500	23 200	1 180
16	97,6	51,6	12	42,6	110	–	3/16	37 500	23 200	1 180
16	97,6	51,6	12	42,6	110	–	3/16	37 500	23 200	1 180
16	97,6	51,6	12	42,6	110	5	–	37 500	23 200	1 180
16	97,6	51,6	12	42,6	110	–	3/16	37 500	23 200	1 180
19	106,1	55,6	12	46,4	125	–	3/16	46 000	29 000	1 480
19	106,1	55,6	12	46,4	125	–	3/16	46 000	29 000	1 480
19	106,1	55,6	12	46,4	125	–	3/16	46 000	29 000	1 480
19	106,1	55,6	12	46,4	125	5	–	46 000	29 000	1 480
19	106,1	55,6	12	46,4	125	–	3/16	46 000	29 000	1 480
19	113,1	65,1	12	56,7	135	–	3/16	56 000	36 000	1 820
19	113,1	65,1	12	56,7	135	–	3/16	56 000	36 000	1 820
19	113,1	65,1	12	56,7	135	5	–	56 000	36 000	1 820
19	113,1	65,1	12	56,7	135	–	3/16	56 000	36 000	1 820
19	113,1	65,1	12	56,7	135	–	3/16	56 000	36 000	1 820



# Four-bolt flanged housing units

Round version  
With grub screws in inner ring

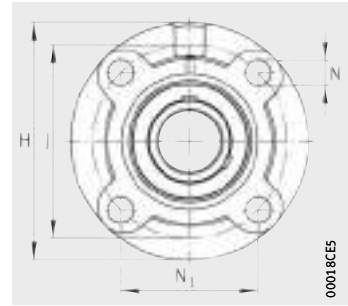

UCFC

**Dimension table** (continued) · Dimensions in mm and inch

Designation			Mass m ≈ kg	Dimensions						
Unit	Housing	Radial insert ball bearing		d		H	J	A	A <sub>1</sub>	A <sub>2</sub>
				mm	inch					
UCFC213-40	FC213	UC213-40	5,55	<b>63,5</b>	<b>2<sup>1</sup>/<sub>2</sub></b>	205	170	36	15	16
UCFC213	FC213	UC213	5,47	<b>65</b>	–	205	170	36	15	16
UCFC213-41	FC213	UC213-41	5,44	<b>65,088</b>	<b>2<sup>9</sup>/<sub>16</sub></b>	205	170	36	15	16
UCFC214-42	FC214	UC214-42	6,84	<b>66,675</b>	<b>2<sup>5</sup>/<sub>8</sub></b>	215	177	40	18	17
UCFC214-43	FC214	UC214-43	6,74	<b>68,263</b>	<b>2<sup>11</sup>/<sub>16</sub></b>	215	177	40	18	17
UCFC214-44	FC214	UC214-44	6,64	<b>69,85</b>	<b>2<sup>3</sup>/<sub>4</sub></b>	215	177	40	18	17
UCFC214	FC214	UC214	6,63	<b>70</b>	–	215	177	40	18	17
UCFC215-45	FC215	UC215-45	7,47	<b>71,438</b>	<b>2<sup>13</sup>/<sub>16</sub></b>	220	184	40	18	18
UCFC215-46	FC215	UC215-46	7,36	<b>73,025</b>	<b>2<sup>7</sup>/<sub>8</sub></b>	220	184	40	18	18
UCFC215-47	FC215	UC215-47	7,25	<b>74,613</b>	<b>2<sup>15</sup>/<sub>16</sub></b>	220	184	40	18	18
UCFC215	FC215	UC215	7,22	<b>75</b>	–	220	184	40	18	18
UCFC215-48	FC215	UC215-48	7,13	<b>76,2</b>	<b>3</b>	220	184	40	18	18
UCFC216-49	FC216	UC216-49	8,95	<b>77,788</b>	<b>3<sup>1</sup>/<sub>16</sub></b>	240	200	42	18	18
UCFC216-50	FC216	UC216-50	8,82	<b>79,375</b>	<b>3<sup>1</sup>/<sub>8</sub></b>	240	200	42	18	18
UCFC216	FC216	UC216	8,8	<b>80</b>	–	240	200	42	18	18
UCFC216-51	FC216	UC216-51	8,69	<b>80,963</b>	<b>3<sup>3</sup>/<sub>16</sub></b>	240	200	42	18	18
UCFC217-52	FC217	UC217-52	10,59	<b>82,55</b>	<b>3<sup>1</sup>/<sub>4</sub></b>	250	208	45	20	18
UCFC217-53	FC217	UC217-53	10,46	<b>84,138</b>	<b>3<sup>5</sup>/<sub>16</sub></b>	250	208	45	20	18
UCFC217	FC217	UC217	10,38	<b>85</b>	–	250	208	45	20	18
UCFC217-55	FC217	UC217-55	10,17	<b>87,313</b>	<b>3<sup>7</sup>/<sub>16</sub></b>	250	208	45	20	18
UCFC218-56	FC218	UC218-56	12,33	<b>88,9</b>	<b>3<sup>1</sup>/<sub>2</sub></b>	265	220	50	20	22
UCFC218	FC218	UC218	12,21	<b>90</b>	–	265	220	50	20	22



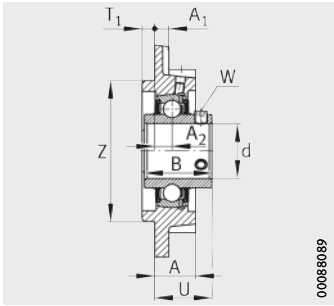

UCFC

N	N <sub>1</sub>	B	T <sub>1</sub>	U	Z	Width across flats		Load carrying capacity Bearing		
						W		Basic load ratings		Fatigue limit load C <sub>ur</sub> N
						mm	inch	dyn. C <sub>r</sub> N	stat. C <sub>0r</sub> N	
19	120,2	65,1	14	55,7	145	-	1/4	61 000	40 000	2 030
19	120,2	65,1	14	55,7	145	6	-	61 000	40 000	2 030
19	120,2	65,1	14	55,7	145	-	1/4	61 000	40 000	2 030
19	125,15	74,6	14	61,4	150	-	1/4	66 000	44 000	2 230
19	125,15	74,6	14	61,4	150	-	1/4	66 000	44 000	2 230
19	125,15	74,6	14	61,4	150	-	1/4	66 000	44 000	2 230
19	125,15	74,6	14	61,4	150	6	-	66 000	44 000	2 230
19	130,1	77,8	16	62,5	160	-	1/4	66 000	44 500	2 240
19	130,1	77,8	16	62,5	160	-	1/4	66 000	44 500	2 240
19	130,1	77,8	16	62,5	160	-	1/4	66 000	44 500	2 240
19	130,1	77,8	16	62,5	160	6	-	66 000	44 500	2 240
19	130,1	77,8	16	62,5	160	-	1/4	66 000	44 500	2 240
23	141,4	82,6	16	67,3	170	-	1/4	76 000	54 000	2 600
23	141,4	82,6	16	67,3	170	-	1/4	76 000	54 000	2 600
23	141,4	82,6	16	67,3	170	6	-	76 000	54 000	2 600
23	141,4	82,6	16	67,3	170	-	1/4	76 000	54 000	2 600
23	147,1	85,7	18	69,6	180	-	1/4	88 000	64 000	2 950
23	147,1	85,7	18	69,6	180	-	1/4	88 000	64 000	2 950
23	147,1	85,7	18	69,6	180	6	-	88 000	64 000	2 950
23	147,1	85,7	18	69,6	180	-	1/4	88 000	64 000	2 950
23	155,55	96	18	78,3	190	-	1/4	102 000	72 000	3 250
23	155,55	96	18	78,3	190	6	-	102 000	72 000	3 250



# Four-bolt flanged housing units

Round version  
With adapter sleeve

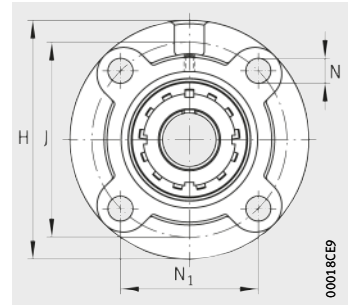

UKFC

**Dimension table** - Dimensions in mm

Designation			Mass m ≈ kg	Dimensions				
Unit	Housing	Radial insert ball bearing		d	H	J	A	A <sub>1</sub>
<b>UKFC205</b>	FC205	UK205	0,99	<b>20</b>	115	90	21	7
<b>UKFC206</b>	FC206	UK206	1,31	<b>25</b>	125	100	23	8
<b>UKFC207</b>	FC207	UK207	1,78	<b>30</b>	135	110	26	9
<b>UKFC208</b>	FC208	UK208	2,12	<b>35</b>	145	120	26	9
<b>UKFC209</b>	FC209	UK209	2,82	<b>40</b>	160	132	26	14
<b>UKFC210</b>	FC210	UK210	3,14	<b>45</b>	165	138	28	14
<b>UKFC211</b>	FC211	UK211	4,15	<b>50</b>	185	150	31	15
<b>UKFC212</b>	FC212	UK212	4,95	<b>55</b>	195	160	36	15
<b>UKFC213</b>	FC213	UK213	5,62	<b>60</b>	205	170	36	15
<b>UKFC215</b>	FC215	UK215	7,7	<b>65</b>	220	184	40	18
<b>UKFC216</b>	FC216	UK216	9,33	<b>70</b>	240	200	42	18
<b>UKFC217</b>	FC217	UK217	10,87	<b>75</b>	250	208	45	20
<b>UKFC218</b>	FC218	UK218	12,76	<b>80</b>	265	220	50	20

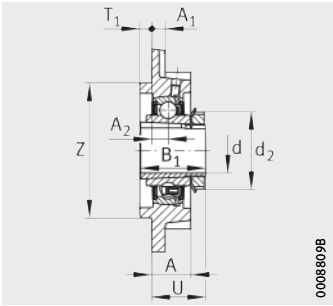

UKFC

								Load carrying capacity Bearing		
								Basic load ratings		Fatigue limit load
A <sub>2</sub>	N	N <sub>1</sub>	B <sub>1</sub>	T <sub>1</sub>	U	Z	d <sub>2</sub>	dyn. C <sub>r</sub> N	stat. C <sub>0r</sub> N	C <sub>ur</sub> N
						h8	max.			
10	12	63,6	35	6	30,7	70	38	14 900	7 800	395
10	12	70,7	38	8	32,2	80	45	20 700	11 300	570
11	14	77,8	43	8	35,7	90	52	27 500	15 300	770
11	14	84,8	46	10	37,7	100	58	34 500	19 800	1 010
10	16	93,3	50	12	38,2	105	65	34 500	20 400	1 030
10	16	97,6	55	12	40,2	110	70	37 500	23 200	1 180
13	19	106,1	59	12	44,2	125	75	46 000	29 000	1 480
17	19	113,1	62	12	51,2	135	80	56 000	36 000	1 820
16	19	120,2	65	14	51,2	145	85	61 000	40 000	2 030
18	19	130,1	73	16	55	160	98	66 000	44 500	2 240
18	23	141,4	78	16	58,2	170	105	76 000	54 000	2 600
18	23	147,1	82	18	60,2	180	110	88 000	64 000	2 950
22	23	155,55	86	18	65,7	190	120	102 000	72 000	3 250



# Take-up housing units

For linear motion  
With grub screws in inner ring

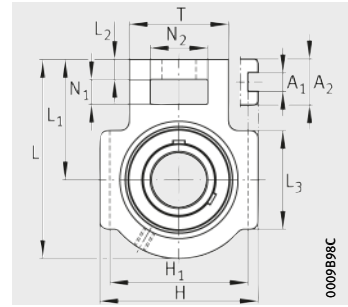

UCT

**Dimension table** - Dimensions in mm and inch

Designation			Mass m ≈ kg	Dimensions							
Unit	Housing	Radial insert ball bearing		d	H	L	L <sub>1</sub>	L <sub>2</sub>	L <sub>3</sub>	A	
											mm
UCT201	T204	UC201	0,77	12	–	89	94	61	10	51	32
UCT201-08	T204	UC201-08	0,77	12,7	1/2	89	94	61	10	51	32
UCT202-09	T204	UC202-09	0,76	14,288	9/16	89	94	61	10	51	32
UCT202	T204	UC202	0,75	15	–	89	94	61	10	51	32
UCT202-10	T204	UC202-10	0,75	15,875	5/8	89	94	61	10	51	32
UCT203	T204	UC203	0,74	17	–	89	94	61	10	51	32
UCT203-11	T204	UC203-11	0,74	17,463	11/16	89	94	61	10	51	32
UCT204-12	T204	UC204-12	0,73	19,05	3/4	89	94	61	10	51	32
UCT204	T204	UC204	0,72	20	–	89	94	61	10	51	32
UCT205-13	T205	UC205-13	0,84	20,638	13/16	89	97	62	10	51	32
UCT205-14	T205	UC205-14	0,83	22,225	7/8	89	97	62	10	51	32
UCT205-15	T205	UC205-15	0,81	23,813	15/16	89	97	62	10	51	32
UCT205	T205	UC205	0,8	25	–	89	97	62	10	51	32
UCT205-16	T205	UC205-16	0,8	25,4	1	89	97	62	10	51	32
UCT206-17	T206	UC206-17	1,27	26,988	11/16	102	113	70	10	57	37
UCT206-18	T206	UC206-18	1,25	28,575	11/8	102	113	70	10	57	37
UCT206	T206	UC206	1,23	30	–	102	113	70	10	57	37
UCT206-19	T206	UC206-19	1,23	30,163	13/16	102	113	70	10	57	37
UCT206-20	T206	UC206-20	1,2	31,75	11/4	102	113	70	10	57	37
UCT207-20	T207	UC207-20	1,64	31,75	11/4	102	129	78	13	64	37
UCT207-21	T207	UC207-21	1,61	33,338	15/16	102	129	78	13	64	37
UCT207-22	T207	UC207-22	1,58	34,925	13/8	102	129	78	13	64	37
UCT207	T207	UC207	1,58	35	–	102	129	78	13	64	37
UCT207-23	T207	UC207-23	1,55	36,513	17/16	102	129	78	13	64	37

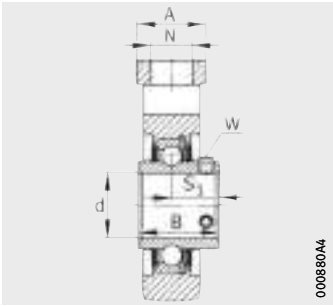

00088044

UCT

									Width across flats		Load carrying capacity Bearing		
									W		Basic load ratings		Fatigue limit load C <sub>ur</sub> N
A <sub>1</sub>	A <sub>2</sub>	H <sub>1</sub>	N	N <sub>1</sub>	N <sub>2</sub>	B	S <sub>1</sub>	T			dyn. C <sub>r</sub> N	stat. C <sub>0r</sub> N	
+0,2/0		0/-0,5							mm	inch			
12	21	76	19	16	32	31	18,3	51	3	–	13 600	6 600	335
12	21	76	19	16	32	31	18,3	51	–	1/8	13 600	6 600	335
12	21	76	19	16	32	31	18,3	51	–	1/8	13 600	6 600	335
12	21	76	19	16	32	31	18,3	51	3	–	13 600	6 600	335
12	21	76	19	16	32	31	18,3	51	–	1/8	13 600	6 600	335
12	21	76	19	16	32	31	18,3	51	3	–	13 600	6 600	335
12	21	76	19	16	32	31	18,3	51	–	1/8	13 600	6 600	335
12	21	76	19	16	32	31	18,3	51	–	1/8	13 600	6 600	335
12	21	76	19	16	32	31	18,3	51	3	–	13 600	6 600	335
12	24	76	19	16	32	34,1	19,8	51	–	1/8	14 900	7 800	395
12	24	76	19	16	32	34,1	19,8	51	–	1/8	14 900	7 800	395
12	24	76	19	16	32	34,1	19,8	51	–	1/8	14 900	7 800	395
12	24	76	19	16	32	34,1	19,8	51	3	–	14 900	7 800	395
12	24	76	19	16	32	34,1	19,8	51	–	1/8	14 900	7 800	395
12	28	89	22	16	37	38,1	22,2	56	–	1/8	20 700	11 300	570
12	28	89	22	16	37	38,1	22,2	56	–	1/8	20 700	11 300	570
12	28	89	22	16	37	38,1	22,2	56	3	–	20 700	11 300	570
12	28	89	22	16	37	38,1	22,2	56	–	1/8	20 700	11 300	570
12	28	89	22	16	37	38,1	22,2	56	–	1/8	20 700	11 300	570
12	30	89	22	16	37	42,9	25,4	64	–	5/32	27 500	15 300	770
12	30	89	22	16	37	42,9	25,4	64	–	5/32	27 500	15 300	770
12	30	89	22	16	37	42,9	25,4	64	–	5/32	27 500	15 300	770
12	30	89	22	16	37	42,9	25,4	64	4	–	27 500	15 300	770
12	30	89	22	16	37	42,9	25,4	64	–	5/32	27 500	15 300	770



# Take-up housing units

For linear motion

With grub screws in inner ring

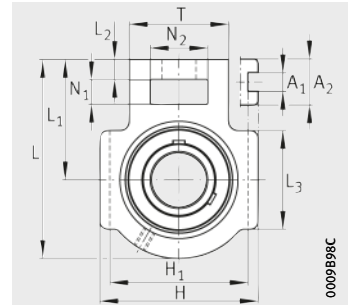

UCT

**Dimension table** (continued) · Dimensions in mm and inch

Designation			Mass m ≈ kg	Dimensions							
Unit	Housing	Radial insert ball bearing		d	H	L	L <sub>1</sub>	L <sub>2</sub>	L <sub>3</sub>	A	
											mm
UCT208-24	T208	UC208-24	2,36	<b>38,1</b>	<b>1 1/2</b>	114	144	88	16	83	49
UCT208-25	T208	UC208-25	2,33	<b>39,688</b>	<b>1 9/16</b>	114	144	88	16	83	49
UCT208	T208	UC208	2,32	<b>40</b>	–	114	144	88	16	83	49
UCT209-26	T209	UC209-26	2,46	<b>41,275</b>	<b>1 5/8</b>	117	144	87	16	83	49
UCT209-27	T209	UC209-27	2,42	<b>42,863</b>	<b>1 11/16</b>	117	144	87	16	83	49
UCT209-28	T209	UC209-28	2,38	<b>44,45</b>	<b>1 3/4</b>	117	144	87	16	83	49
UCT209	T209	UC209	2,37	<b>45</b>	–	117	144	87	16	83	49
UCT210-29	T210	UC210-29	2,64	<b>46,038</b>	<b>1 13/16</b>	117	149	90	16	86	49
UCT210-30	T210	UC210-30	2,59	<b>47,625</b>	<b>1 7/8</b>	117	149	90	16	86	49
UCT210-31	T210	UC210-31	2,54	<b>49,213</b>	<b>1 15/16</b>	117	149	90	16	86	49
UCT210	T210	UC210	2,52	<b>50</b>	–	117	149	90	16	86	49
UCT210-32	T210	UC210-32	2,5	<b>50,8</b>	<b>2</b>	117	149	90	16	86	49
UCT211-32	T211	UC211-32	3,98	<b>50,8</b>	<b>2</b>	146	171	106	19	95	64
UCT211-33	T211	UC211-33	3,93	<b>52,388</b>	<b>2 1/16</b>	146	171	106	19	95	64
UCT211-34	T211	UC211-34	3,87	<b>53,975</b>	<b>2 1/8</b>	146	171	106	19	95	64
UCT211	T211	UC211	3,83	<b>55</b>	–	146	171	106	19	95	64
UCT211-35	T211	UC211-35	3,81	<b>55,563</b>	<b>2 3/16</b>	146	171	106	19	95	64
UCT212-36	T212	UC212-36	4,84	<b>57,15</b>	<b>2 1/4</b>	146	194	119	19	102	64
UCT212-37	T212	UC212-37	4,77	<b>58,738</b>	<b>2 5/16</b>	146	194	119	19	102	64
UCT212	T212	UC212	4,71	<b>60</b>	–	146	194	119	19	102	64
UCT212-38	T212	UC212-38	4,69	<b>60,325</b>	<b>2 3/8</b>	146	194	119	19	102	64
UCT212-39	T212	UC212-39	4,61	<b>61,913</b>	<b>2 7/16</b>	146	194	119	19	102	64

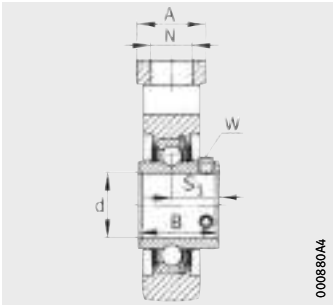

UCT

									Width across flats		Load carrying capacity Bearing		
											Basic load ratings		Fatigue limit load C <sub>ur</sub> N
A <sub>1</sub>	A <sub>2</sub>	H <sub>1</sub>	N	N <sub>1</sub>	N <sub>2</sub>	B	S <sub>1</sub>	T	W		dyn. C <sub>r</sub> N	stat. C <sub>0r</sub> N	
+0,3/0		0/-0,8							mm	inch			
16	33	102	29	19	49	49,2	30,2	83	-	5/32	34 500	19 800	1 010
16	33	102	29	19	49	49,2	30,2	83	-	5/32	34 500	19 800	1 010
16	33	102	29	19	49	49,2	30,2	83	4	-	34 500	19 800	1 010
16	35	102	29	19	49	49,2	30,2	83	-	5/32	34 500	20 400	1 030
16	35	102	29	19	49	49,2	30,2	83	-	5/32	34 500	20 400	1 030
16	35	102	29	19	49	49,2	30,2	83	-	5/32	34 500	20 400	1 030
16	35	102	29	19	49	49,2	30,2	83	4	-	34 500	20 400	1 030
16	37	102	29	19	49	51,6	32,6	83	-	3/16	37 500	23 200	1 180
16	37	102	29	19	49	51,6	32,6	83	-	3/16	37 500	23 200	1 180
16	37	102	29	19	49	51,6	32,6	83	-	3/16	37 500	23 200	1 180
16	37	102	29	19	49	51,6	32,6	83	5	-	37 500	23 200	1 180
16	37	102	29	19	49	51,6	32,6	83	-	3/16	37 500	23 200	1 180
22	38	130	35	25	64	55,6	33,4	102	-	3/16	46 000	29 000	1 480
22	38	130	35	25	64	55,6	33,4	102	-	3/16	46 000	29 000	1 480
22	38	130	35	25	64	55,6	33,4	102	-	3/16	46 000	29 000	1 480
22	38	130	35	25	64	55,6	33,4	102	5	-	46 000	29 000	1 480
22	38	130	35	25	64	55,6	33,4	102	-	3/16	46 000	29 000	1 480
22	42	130	35	32	64	65,1	39,7	102	-	3/16	56 000	36 000	1 820
22	42	130	35	32	64	65,1	39,7	102	-	3/16	56 000	36 000	1 820
22	42	130	35	32	64	65,1	39,7	102	5	-	56 000	36 000	1 820
22	42	130	35	32	64	65,1	39,7	102	-	3/16	56 000	36 000	1 820
22	42	130	35	32	64	65,1	39,7	102	-	3/16	56 000	36 000	1 820



# Take-up housing units

For linear motion

With grub screws in inner ring

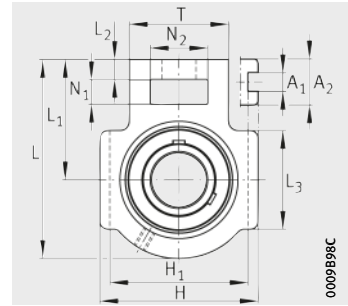

UCT

**Dimension table** (continued) · Dimensions in mm and inch

Designation			Mass m ≈ kg	Dimensions							
Unit	Housing	Radial insert ball bearing		d	H	L	L <sub>1</sub>	L <sub>2</sub>	L <sub>3</sub>	A	
											mm
UCT213-40	T213	UC213-40	6,68	<b>63,5</b>	<b>2<sup>1</sup>/<sub>2</sub></b>	167	224	137	21	121	70
UCT213	T213	UC213	6,61	<b>65</b>	–	167	224	137	21	121	70
UCT213-41	T213	UC213-41	6,61	<b>65,088</b>	<b>2<sup>9</sup>/<sub>16</sub></b>	167	224	137	21	121	70
UCT214-42	T214	UC214-42	6,99	<b>66,675</b>	<b>2<sup>5</sup>/<sub>8</sub></b>	167	224	137	21	121	70
UCT214-43	T214	UC214-43	6,89	<b>68,263</b>	<b>2<sup>11</sup>/<sub>16</sub></b>	167	224	137	21	121	70
UCT214-44	T214	UC214-44	6,79	<b>69,85</b>	<b>2<sup>3</sup>/<sub>4</sub></b>	167	224	137	21	121	70
UCT214	T214	UC214	6,78	<b>70</b>	–	167	224	137	21	121	70
UCT215-45	T215	UC215-45	7,45	<b>71,438</b>	<b>2<sup>13</sup>/<sub>16</sub></b>	167	232	140	21	121	70
UCT215-46	T215	UC215-46	7,34	<b>73,025</b>	<b>2<sup>7</sup>/<sub>8</sub></b>	167	232	140	21	121	70
UCT215-47	T215	UC215-47	7,23	<b>74,613</b>	<b>2<sup>15</sup>/<sub>16</sub></b>	167	232	140	21	121	70
UCT215	T215	UC215	7,2	<b>75</b>	–	167	232	140	21	121	70
UCT215-48	T215	UC215-48	7,12	<b>76,2</b>	<b>3</b>	167	232	140	21	121	70
UCT216-49	T216	UC216-49	8,27	<b>77,788</b>	<b>3<sup>1</sup>/<sub>16</sub></b>	184	235	140	21	121	70
UCT216-50	T216	UC216-50	8,15	<b>79,375</b>	<b>3<sup>1</sup>/<sub>8</sub></b>	184	235	140	21	121	70
UCT216	T216	UC216	8,09	<b>80</b>	–	184	235	140	21	121	70
UCT216-51	T216	UC216-51	8,01	<b>80,963</b>	<b>3<sup>3</sup>/<sub>16</sub></b>	184	235	140	21	121	70
UCT217-52	T217	UC217-52	10,9	<b>82,55</b>	<b>3<sup>1</sup>/<sub>4</sub></b>	198	260	162	29	157	73
UCT217-53	T217	UC217-53	10,8	<b>84,138</b>	<b>3<sup>5</sup>/<sub>16</sub></b>	198	260	162	29	157	73
UCT217	T217	UC217	10,7	<b>85</b>	–	198	260	162	29	157	73
UCT217-55	T217	UC217-55	10,5	<b>87,313</b>	<b>3<sup>7</sup>/<sub>16</sub></b>	198	260	162	29	157	73
UCT218-56	T218	UC218-56	12,37	<b>88,9</b>	<b>3<sup>1</sup>/<sub>2</sub></b>	215	275	170	30	140	80
UCT218	T218	UC218	12,26	<b>90</b>	–	215	275	170	30	140	80



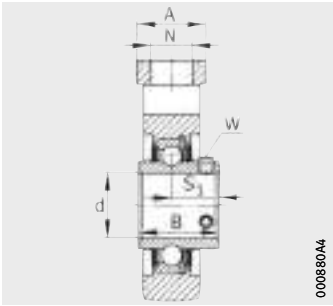

UCT

A <sub>1</sub>	A <sub>2</sub>	H <sub>1</sub>	N	N <sub>1</sub>	N <sub>2</sub>	B	S <sub>1</sub>	T	Width across flats		Load carrying capacity Bearing		
									W		Basic load ratings		Fatigue limit load C <sub>ur</sub> N
									mm	inch	dyn. C <sub>r</sub> N	stat. C <sub>0r</sub> N	
+0,3/0		0/-0,8											
26	44	151	41	32	70	65,1	39,7	111	–	1/4	61 000	40 000	2 030
26	44	151	41	32	70	65,1	39,7	111	6	–	61 000	40 000	2 030
26	44	151	41	32	70	65,1	39,7	111	–	1/4	61 000	40 000	2 030
26	46	151	41	32	70	74,6	44,4	111	–	1/4	66 000	44 000	2 230
26	46	151	41	32	70	74,6	44,4	111	–	1/4	66 000	44 000	2 230
26	46	151	41	32	70	74,6	44,4	111	–	1/4	66 000	44 000	2 230
26	46	151	41	32	70	74,6	44,4	111	6	–	66 000	44 000	2 230
26	48	151	41	32	70	77,8	44,5	111	–	1/4	66 000	44 500	2 240
26	48	151	41	32	70	77,8	44,5	111	–	1/4	66 000	44 500	2 240
26	48	151	41	32	70	77,8	44,5	111	–	1/4	66 000	44 500	2 240
26	48	151	41	32	70	77,8	44,5	111	6	–	66 000	44 500	2 240
26	48	151	41	32	70	77,8	44,5	111	–	1/4	66 000	44 500	2 240
26	51	165	41	32	70	82,6	49,3	111	–	1/4	76 000	54 000	2 600
26	51	165	41	32	70	82,6	49,3	111	–	1/4	76 000	54 000	2 600
26	51	165	41	32	70	82,6	49,3	111	6	–	76 000	54 000	2 600
26	51	165	41	32	70	82,6	49,3	111	–	1/4	76 000	54 000	2 600
30	54	173	48	38	73	85,7	51,6	124	–	1/4	88 000	64 000	2 950
30	54	173	48	38	73	85,7	51,6	124	–	1/4	88 000	64 000	2 950
30	54	173	48	38	73	85,7	51,6	124	6	–	88 000	64 000	2 950
30	54	173	48	38	73	85,7	51,6	124	–	1/4	88 000	64 000	2 950
28	55	190	47	40	80	96	56,3	130	–	1/4	102 000	72 000	3 250
28	55	190	47	40	80	96	56,3	130	6	–	102 000	72 000	3 250



# Take-up housing units

For linear motion  
With adapter sleeve

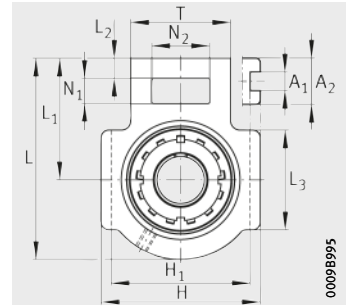

UKT

**Dimension table** - Dimensions in mm

Designation			Mass m ≈ kg	Dimensions						
Unit	Housing	Radial insert ball bearing		d	H	L	L <sub>1</sub>	L <sub>2</sub>	L <sub>3</sub>	A
UKT205	T205	UK205	0,85	20	89	97	62	10	51	32
UKT206	T206	UK206	1,29	25	102	113	70	10	57	37
UKT207	T207	UK207	1,66	30	102	129	78	13	64	37
UKT208	T208	UK208	2,4	35	114	144	88	16	83	49
UKT209	T209	UK209	2,5	40	117	144	87	16	83	49
UKT210	T210	UK210	2,7	45	117	149	90	16	86	49
UKT211	T211	UK211	4	50	146	171	106	19	95	64
UKT212	T212	UK212	4,79	55	146	194	119	19	102	64
UKT213	T213	UK213	6,76	60	167	224	137	21	121	70
UKT215	T215	UK215	7,69	65	167	232	140	21	121	70
UKT216	T216	UK216	8,6	70	184	235	140	21	121	70
UKT217	T217	UK217	11,2	75	198	260	162	29	157	73
UKT218	T218	UK218	12,78	80	215	275	170	30	140	80

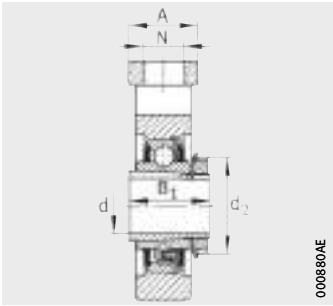

000880AE

UKT

									Load carrying capacity Bearing		
									Basic load ratings		Fatigue limit load
A <sub>1</sub>	A <sub>2</sub>	H <sub>1</sub>	N	N <sub>1</sub>	N <sub>2</sub>	B <sub>1</sub>	T	d <sub>2</sub> max.	dyn. C <sub>r</sub> N	stat. C <sub>0r</sub> N	C <sub>ur</sub> N
12 <sup>+0,2</sup> <sub>0</sub>	24	76 <sup>0</sup> <sub>-0,5</sub>	19	16	32	35	51	38	14 900	7 800	395
12 <sup>+0,2</sup> <sub>0</sub>	28	89 <sup>0</sup> <sub>-0,5</sub>	22	16	37	38	56	45	20 700	11 300	570
12 <sup>+0,2</sup> <sub>0</sub>	30	89 <sup>0</sup> <sub>-0,5</sub>	22	16	37	43	64	52	27 500	15 300	770
16 <sup>+0,2</sup> <sub>0</sub>	33	102 <sup>0</sup> <sub>-0,5</sub>	29	19	49	46	83	58	34 500	19 800	1 010
16 <sup>+0,2</sup> <sub>0</sub>	35	102 <sup>0</sup> <sub>-0,5</sub>	29	19	49	50	83	65	34 500	20 400	1 030
16 <sup>+0,2</sup> <sub>0</sub>	37	102 <sup>0</sup> <sub>-0,5</sub>	29	19	49	55	83	70	37 500	23 200	1 180
22 <sup>+0,3</sup> <sub>0</sub>	38	130 <sup>0</sup> <sub>-0,8</sub>	35	25	64	59	102	75	46 000	29 000	1 480
22 <sup>+0,3</sup> <sub>0</sub>	42	130 <sup>0</sup> <sub>-0,8</sub>	35	32	64	62	102	80	56 000	36 000	1 820
26 <sup>+0,3</sup> <sub>0</sub>	44	151 <sup>0</sup> <sub>-0,8</sub>	41	32	70	65	111	85	61 000	40 000	2 030
26 <sup>+0,3</sup> <sub>0</sub>	48	151 <sup>0</sup> <sub>-0,8</sub>	41	32	70	73	111	98	66 000	44 500	2 240
26 <sup>+0,3</sup> <sub>0</sub>	51	165 <sup>0</sup> <sub>-0,8</sub>	41	32	70	78	111	105	76 000	54 000	2 600
30 <sup>+0,3</sup> <sub>0</sub>	54	173 <sup>0</sup> <sub>-0,8</sub>	48	38	73	82	124	110	88 000	64 000	2 950
28 <sup>+0,3</sup> <sub>0</sub>	55	190 <sup>0</sup> <sub>-0,8</sub>	47	40	80	86	130	120	102 000	72 000	3 250



# Take-up housing units

For swivel motion  
With grub screws in inner ring

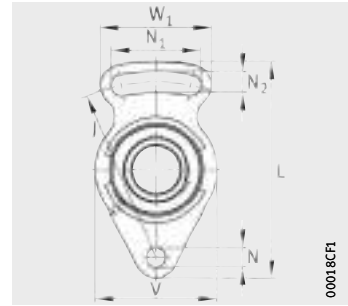

UCFA

**Dimension table** - Dimensions in mm and inch

Designation			Mass m ≈ kg	Dimensions						
Unit	Housing	Radial insert ball bearing		d		J	L	A	A <sub>1</sub>	A <sub>2</sub>
				mm	inch					
<b>UCFA201</b>	FA204	UC201	0,45	<b>12</b>	–	78	98	25,5	12	15
<b>UCFA201-08</b>	FA204	UC201-08	0,44	<b>12,7</b>	<b>1/2</b>	78	98	25,5	12	15
<b>UCFA202-09</b>	FA204	UC202-09	0,43	<b>14,288</b>	<b>9/16</b>	78	98	25,5	12	15
<b>UCFA202</b>	FA204	UC202	0,43	<b>15</b>	–	78	98	25,5	12	15
<b>UCFA202-10</b>	FA204	UC202-10	0,43	<b>15,875</b>	<b>5/8</b>	78	98	25,5	12	15
<b>UCFA203</b>	FA204	UC203	0,42	<b>17</b>	–	78	98	25,5	12	15
<b>UCFA203-11</b>	FA204	UC203-11	0,42	<b>17,463</b>	<b>11/16</b>	78	98	25,5	12	15
<b>UCFA204-12</b>	FA204	UC204-12	0,41	<b>19,05</b>	<b>3/4</b>	78	98	25,5	12	15
<b>UCFA204</b>	FA204	UC204	0,41	<b>20</b>	–	78	98	25,5	12	15
<b>UCFA205-13</b>	FA205	UC205-13	0,67	<b>20,638</b>	<b>13/16</b>	98	125	27	14	16
<b>UCFA205-14</b>	FA205	UC205-14	0,66	<b>22,225</b>	<b>7/8</b>	98	125	27	14	16
<b>UCFA205-15</b>	FA205	UC205-15	0,64	<b>23,813</b>	<b>15/16</b>	98	125	27	14	16
<b>UCFA205</b>	FA205	UC205	0,63	<b>25</b>	–	98	125	27	14	16
<b>UCFA205-16</b>	FA205	UC205-16	0,62	<b>25,4</b>	<b>1</b>	98	125	27	14	16
<b>UCFA206-17</b>	FA206	UC206-17	0,94	<b>26,988</b>	<b>11/16</b>	117	144	31	14	18
<b>UCFA206-18</b>	FA206	UC206-18	0,92	<b>28,575</b>	<b>11/8</b>	117	144	31	14	18
<b>UCFA206</b>	FA206	UC206	0,9	<b>30</b>	–	117	144	31	14	18
<b>UCFA206-19</b>	FA206	UC206-19	0,9	<b>30,163</b>	<b>13/16</b>	117	144	31	14	18
<b>UCFA206-20</b>	FA206	UC206-20	0,88	<b>31,75</b>	<b>11/4</b>	117	144	31	14	18

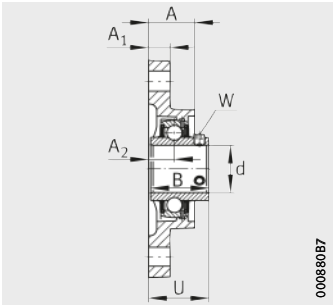

UCFA

N							Width across flats		Load carrying capacity Bearing		
									Basic load ratings		Fatigue limit load $C_{ur}$ N
							$N_1$	$N_2$	B	U	
10	40	10	31	33,3	60	50	3	-	13 600	6 600	335
10	40	10	31	33,3	60	50	-	1/8	13 600	6 600	335
10	40	10	31	33,3	60	50	-	1/8	13 600	6 600	335
10	40	10	31	33,3	60	50	3	-	13 600	6 600	335
10	40	10	31	33,3	60	50	-	1/8	13 600	6 600	335
10	40	10	31	33,3	60	50	3	-	13 600	6 600	335
10	40	10	31	33,3	60	50	-	1/8	13 600	6 600	335
10	40	10	31	33,3	60	50	-	1/8	13 600	6 600	335
10	40	10	31	33,3	60	50	3	-	13 600	6 600	335
12	51	12	34,1	35,8	68	66	-	1/8	14 900	7 800	395
12	51	12	34,1	35,8	68	66	-	1/8	14 900	7 800	395
12	51	12	34,1	35,8	68	66	-	1/8	14 900	7 800	395
12	51	12	34,1	35,8	68	66	3	-	14 900	7 800	395
12	51	12	34,1	35,8	68	66	-	1/8	14 900	7 800	395
12	58	12	38,1	40,2	80	72	-	1/8	20 700	11 300	570
12	58	12	38,1	40,2	80	72	-	1/8	20 700	11 300	570
12	58	12	38,1	40,2	80	72	3	-	20 700	11 300	570
12	58	12	38,1	40,2	80	72	-	1/8	20 700	11 300	570
12	58	12	38,1	40,2	80	72	-	1/8	20 700	11 300	570



# Take-up housing units

For swivel motion  
With grub screws in inner ring

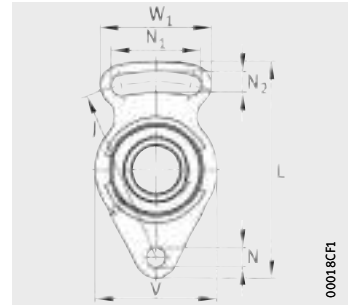

UCFA

**Dimension table** (continued) · Dimensions in mm and inch

Designation			Mass m ≈ kg	Dimensions						
Unit	Housing	Radial insert ball bearing		d		J	L	A	A <sub>1</sub>	A <sub>2</sub>
				mm	inch					
UCFA207-20	FA207	UC207-20	1,29	<b>31,75</b>	<b>1<sup>1</sup>/<sub>4</sub></b>	130	161	34	16	19
UCFA207-21	FA207	UC207-21	1,26	<b>33,338</b>	<b>1<sup>5</sup>/<sub>16</sub></b>	130	161	34	16	19
UCFA207-22	FA207	UC207-22	1,24	<b>34,925</b>	<b>1<sup>3</sup>/<sub>8</sub></b>	130	161	34	16	19
UCFA207	FA207	UC207	1,23	<b>35</b>	–	130	161	34	16	19
UCFA207-23	FA207	UC207-23	1,21	<b>36,513</b>	<b>1<sup>7</sup>/<sub>16</sub></b>	130	161	34	16	19
UCFA208-24	FA208	UC208-24	1,58	<b>38,1</b>	<b>1<sup>1</sup>/<sub>2</sub></b>	144	175	36	16	21
UCFA208-25	FA208	UC208-25	1,54	<b>39,688</b>	<b>1<sup>9</sup>/<sub>16</sub></b>	144	175	36	16	21
UCFA208	FA208	UC208	1,53	<b>40</b>	–	144	175	36	16	21
UCFA209-26	FA209	UC209-26	1,99	<b>41,275</b>	<b>1<sup>5</sup>/<sub>8</sub></b>	148	181	38	18	22
UCFA209-27	FA209	UC209-27	1,95	<b>42,863</b>	<b>1<sup>11</sup>/<sub>16</sub></b>	148	181	38	18	22
UCFA209-28	FA209	UC209-28	1,91	<b>44,45</b>	<b>1<sup>3</sup>/<sub>4</sub></b>	148	181	38	18	22
UCFA209	FA209	UC209	1,9	<b>45</b>	–	148	181	38	18	22
UCFA210-29	FA210	UC210-29	2,2	<b>46,038</b>	<b>1<sup>13</sup>/<sub>16</sub></b>	157	190	37,5	18	22
UCFA210-30	FA210	UC210-30	2,16	<b>47,625</b>	<b>1<sup>7</sup>/<sub>8</sub></b>	157	190	37,5	18	22
UCFA210-31	FA210	UC210-31	2,11	<b>49,213</b>	<b>1<sup>15</sup>/<sub>16</sub></b>	157	190	37,5	18	22
UCFA210	FA210	UC210	2,08	<b>50</b>	–	157	190	37,5	18	22
UCFA210-32	FA210	UC210-32	2,06	<b>50,8</b>	<b>2</b>	157	190	37,5	18	22
UCFA211-32	FA211	UC211-32	3,1	<b>50,8</b>	<b>2</b>	184	219	43	20	25
UCFA211-33	FA211	UC211-33	3,05	<b>52,388</b>	<b>2<sup>1</sup>/<sub>16</sub></b>	184	219	43	20	25
UCFA211-34	FA211	UC211-34	2,99	<b>53,975</b>	<b>2<sup>1</sup>/<sub>8</sub></b>	184	219	43	20	25
UCFA211	FA211	UC211	2,95	<b>55</b>	–	184	219	43	20	25
UCFA211-35	FA211	UC211-35	2,93	<b>55,563</b>	<b>2<sup>3</sup>/<sub>16</sub></b>	184	219	43	20	25

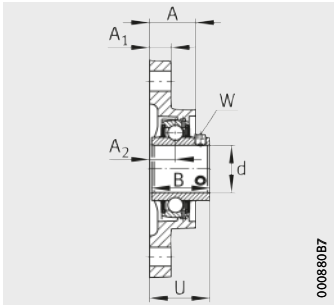

000880B7

UCFA

N	N <sub>1</sub>	N <sub>2</sub>	B	U	V	W <sub>1</sub>	Width across flats		Load carrying capacity Bearing		
							W		Basic load ratings		Fatigue limit load C <sub>ur</sub> N
									dyn. C <sub>r</sub> N	stat. C <sub>0r</sub> N	
		mm	inch								
14	66	14	42,9	44,4	90	82	–	5/32	27 500	15 300	770
14	66	14	42,9	44,4	90	82	–	5/32	27 500	15 300	770
14	66	14	42,9	44,4	90	82	–	5/32	27 500	15 300	770
14	66	14	42,9	44,4	90	82	4	–	27 500	15 300	770
14	66	14	42,9	44,4	90	82	–	5/32	27 500	15 300	770
14	71	14	49,2	51,2	100	87	–	5/32	34 500	19 800	1010
14	71	14	49,2	51,2	100	87	–	5/32	34 500	19 800	1010
14	71	14	49,2	51,2	100	87	4	–	34 500	19 800	1010
16	72	16	49,2	52,2	108	90	–	5/32	34 500	20 400	1030
16	72	16	49,2	52,2	108	90	–	5/32	34 500	20 400	1030
16	72	16	49,2	52,2	108	90	–	5/32	34 500	20 400	1030
16	72	16	49,2	52,2	108	90	4	–	34 500	20 400	1030
16	76	16	51,6	54,6	115	94	–	3/16	37 500	23 200	1180
16	76	16	51,6	54,6	115	94	–	3/16	37 500	23 200	1180
16	76	16	51,6	54,6	115	94	–	3/16	37 500	23 200	1180
16	76	16	51,6	54,6	115	94	5	–	37 500	23 200	1180
16	76	16	51,6	54,6	115	94	–	3/16	37 500	23 200	1180
16	86	16	55,6	58,4	130	104	–	3/16	46 000	29 000	1480
16	86	16	55,6	58,4	130	104	–	3/16	46 000	29 000	1480
16	86	16	55,6	58,4	130	104	–	3/16	46 000	29 000	1480
16	86	16	55,6	58,4	130	104	5	–	46 000	29 000	1480
16	86	16	55,6	58,4	130	104	–	3/16	46 000	29 000	1480









## Other products

Tillage and harvesting  
Conveying equipment  
Textile machinery  
Food industry  
Ventilators





## Other products

	Page	
<b>Bearing arrangements for tillage and harvesting</b>	Product overview .....	554
	Features	
	Flanged housing units with sheet steel housing .....	556
	Flanged housing units for drums .....	557
	Flanged housing units for harvesters .....	558
	Sealing .....	559
	Lubrication .....	560
	Operating temperature .....	560
	Suffixes .....	560
	Design and safety guidelines	
	Compensation of static misalignments .....	561
Dimension tables .....	562	
<b>Bearing arrangements for conveying equipment</b>	Product overview .....	568
	Features	
	Location on shaft .....	569
	Anti-corrosion protection .....	569
	Sealing .....	569
	Lubrication .....	569
	Operating temperature .....	569
	Suffixes .....	569
	Dimension tables .....	570
	<b>Bearing arrangements for textile machinery</b>	Product overview .....
Features		
Radial insert ball bearings .....		573
Plummer block housing units .....		574
Flanged housing units .....		575
Anti-corrosion protection .....		575
Operating temperature .....		575
Suffixes .....		575
Dimension tables .....		576
<b>Flanged housing units for the food industry</b>		Product overview .....
	Features	
	Location on shaft .....	579
	Location on adjacent construction .....	579
	Anti-corrosion protection .....	580
	Sealing .....	580
	Lubrication .....	580
	Operating temperatures .....	580
	Suffixes .....	580
	Design and safety guidelines	
	Axial load carrying capacity .....	581
Bearing end caps .....	581	
Dimension tables .....	582	
<b>Take-up housing units for ventilators</b>	Product overview .....	584
	Features .....	585



# Product overview **Bearing arrangements for tillage and harvesting**

## Flanged housing units for plough discs

TRV..-IA02



## Flanged housing units for drums

IBBU..-IA03



RCJT..-IA03



RCJ..-IA03, TCJY..-IA03



**Flanged housing units  
for harvesters**

RMEY..-IA04



TME..-IA04



RME..-IA04



RMEO..-IA04



IBBU..-IA04



**Plummer block housing units  
for harvesters**

TSHEV..-IA04



# Bearing arrangements for tillage and harvesting

## Features

The following sections describe selected bearing arrangements for use in machinery for tillage and harvesting. Bearing arrangements for seed discs, plough discs, drums and harvesters require seals, see page 559, that give complete protection of the rolling elements against the environmental conditions in agricultural operations.

In addition, Schaeffler develops and manufactures further products for agricultural engineering use in consultation with the customer.

## Further information

- TPI 220, Bearing arrangements for tillage and harvesting
- Download and ordering: <http://medien.schaeffler.de>.

## Flanged housing units with sheet steel housing

The two sheet steel halves are riveted together, *Figure 1*. The unit is positioned on a square section shaft by means of spacers. The sheet steel halves protect the seal system against mechanical damage and, in addition, form a prechamber for grease.

① Prechamber greased

*Figure 1*  
Four-bolt flanged housing unit with sheet steel housing and square bore

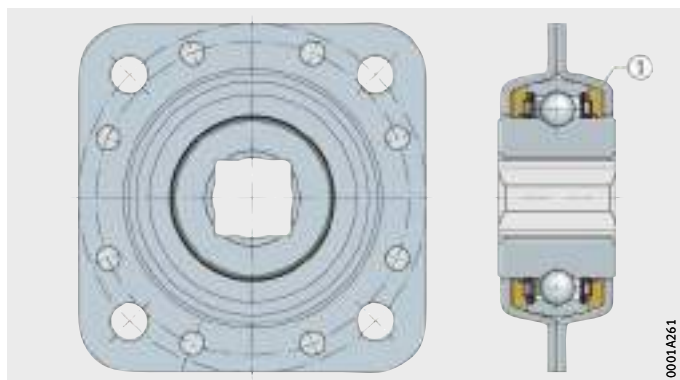

## Preload

Once the bearing system is mounted, it operates almost free from clearance.

## Sealing

Housing units for plough discs are sealed on both sides by means of a triple lip seal, *Figure 2*.

The seals are additionally protected by a steel plate against mechanical damage and high pressure cleaning equipment.

① T seal

*Figure 2*  
Sealing of bearing

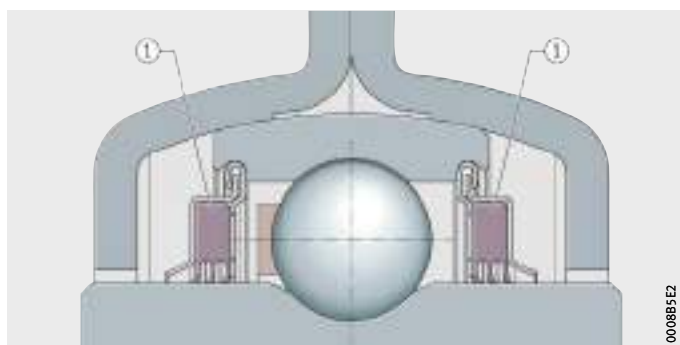

## Lubrication

Grease prechambers provide lubrication of the seal lips and thus prevent dry running.

## Flanged housing units for drums

Flanged housing units for drums comprise a machined cast housing and a self-aligning bearing as well as additional flinger shields, *Figure 3*.

In general, the housings are made from spheroidal graphite cast iron. They are designed for the high requirements present at the operating location. They can securely support shock loads.

Due to the spherical shape of the outer ring, the bearing can align itself during mounting of the unit. As a result, small misalignments can be compensated.

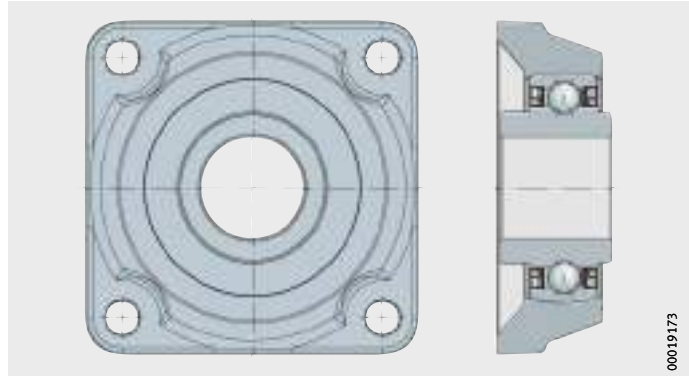

*Figure 3*  
Flanged housing unit for drums

### Corrotect coating

In order that the seal can remain effective in the long term, the inner ring has a Corrotect coating. This prevents penetration of rust under the seal due to corrosion of the inner ring.

### Sealing

Housing units for drums are sealed on both sides by means of a triple lip seal. In addition, the seals are protected by flinger shields against mechanical damage and high pressure cleaning equipment, which means that it is possible to operate these units without maintenance.

### Lubrication

The flinger shields are either pressed onto the inner ring or are staked with the inner ring or housing. They are fitted such that there is a narrow gap and a prechamber of a labyrinth design for the grease. The seal is lubricated by the grease and the friction is reduced at the same time.



# Bearing arrangements for tillage and harvesting

## Flanged housing units for harvesters

Flanged housing units for harvesting generally comprise a machined cast housing and a self-aligning bearing, *Figure 4*.

The housings are normally made from spheroidal graphite cast iron. They are designed for the high requirements present at the operating location. They can securely support shock loads.

Due to the spherical shape of the outer ring, the bearing can align itself during mounting of the unit. Slight misalignments can thus be compensated.

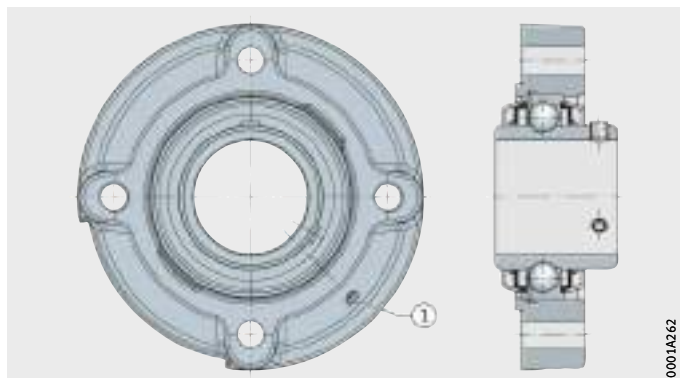

① Threaded hole in housing

*Figure 4*  
Flanged housing unit for harvesting

### Corrotect coating

In order that the seal can remain effective in the long term, the inner ring has a Corrotect coating. This prevents penetration of rust under the seal due to corrosion of the inner ring.

### Sealing

Housing units for harvesters are normally sealed on both sides by means of a triple lip seal. In addition, the seals are normally protected by flinger shields against mechanical damage and high pressure cleaning equipment.



### Lubrication

Most units are designed with a threaded hole in the housing and can thus be relubricated by means of an appropriate lubrication nipple. Relubrication of the bearing is facilitated where necessary by means of two lubrication holes offset by 180° in the outer ring.

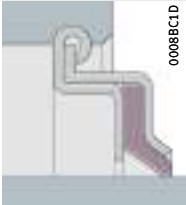
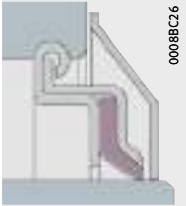
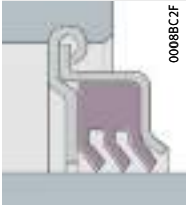

**Sealing** Some seals for agricultural engineering are of a multi-piece design, see table. This concept offers, due to the rigidly rolled-in sheet steel washer, optimum seating in the bearing as well as concentric alignment of the seal lip to the inner ring.

**Seal types**

<b>R seal</b>	
	<p>0008BC1D</p> <p>Two zinc-coated sheet steel washers extended outwards and angled downwards with intermediate NBR part and radially preloaded seal lip. Improved protection against mechanical damage.</p> <p>Large grease reservoir due to the space between the extended and angled sheet steel washers. For use in radial insert ball bearings with inner ring extended on both sides.</p>
<b>R seal with flinger shield</b>	
	<p>0008BC76</p> <p>As R seal, but with outer flinger shield with anti-corrosion protection.</p> <p>Additional sealing action without restriction on speed and with additional protection against mechanical damage and high pressure cleaning equipment.</p>
<b>T seal</b>	
	<p>0008BC7F</p> <p>Two zinc-plated sheet steel washers with intermediate NBR part and three radially preloaded seal lips for protection against extreme contamination.</p> <p>For better protection of the seal lip against mechanical damage, the outer sheet steel washer is extended outwards and angled downwards.</p> <p>Lower speeds due to higher friction.</p>
<b>Sealing cartridge with flinger shield</b>	
	<p>0008BC38</p> <p>Design identical to normal cartridge seal but supplemented by a flinger shield to protect the bearing against high pressure cleaning equipment and mechanical damage.</p>
<b>Combined sealing washer and flinger shield with protective shield</b>	
	<p>0008BC41</p> <p>Design identical to normal sealing washer and flinger shield but supplemented by a protective shield to protect the bearing against high pressure cleaning equipment and mechanical damage.</p>



# Bearing arrangements for tillage and harvesting

## Lubrication

In general, bearing arrangements in the tillage sector cannot be relubricated. However, relubrication of the bearings in the harvesting sector may be necessary. A suitable solution is a lithium soap grease with a base oil viscosity ISO VG 68 or higher, for example the rolling bearing grease MULTITOP or MULTI2.

Relubrication should be carried out with the bearing rotating and still warm from operation in order to achieve good replacement and distribution of grease.

## Operating temperature

Open bearings can be used at operating temperatures from  $-20\text{ }^{\circ}\text{C}$  to  $+120\text{ }^{\circ}\text{C}$ .



Sealed bearings are suitable for operating temperatures from  $-20\text{ }^{\circ}\text{C}$  to  $+100\text{ }^{\circ}\text{C}$ , restricted by the grease and seal material.

## Suffixes

Suffixes for available designs, see table.

### Available designs

Suffix	Description	Design
IA02	Flanged housing units for plough discs	Standard
IA03	Flanged housing units for drums	
IA04	Flanged housing units for harvesters	

## Design and safety guidelines

### Compensation of static misalignments

Bearings with a spherical outside surface of the bearing outer ring, fitted in housings with a concave bore, can compensate for static misalignment of the shaft or housing, *Figure 5* and *Figure 6*:

For units with a lubrication groove in the housing and a lubrication hole in the radial insert ball bearing, the following applies:

- Up to  $\pm 2,5^\circ$ , the units can be relubricated.
- Between  $\pm 2,5^\circ$  and  $\pm 5^\circ$ , the facility for relubrication is dependent on the specific unit. Please contact us in this case.
- Above  $\pm 5^\circ$ , relubrication is no longer possible.



The units must not be used to support swivelling or tumbling motion in dynamic operation.

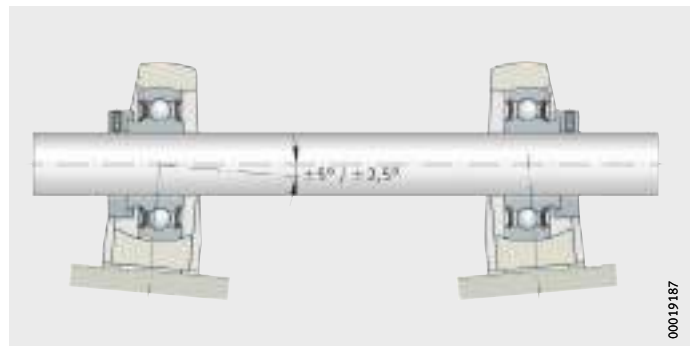

*Figure 5*  
Compensation of static housing misalignment

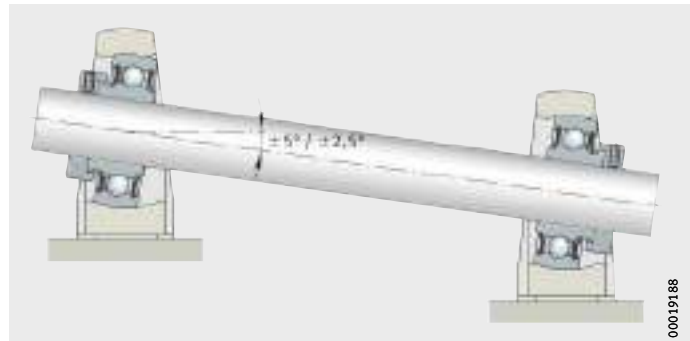
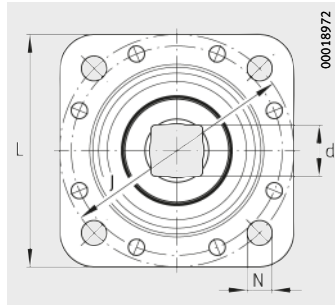

*Figure 6*  
Compensation of static shaft misalignment



# Flanged housing units for plough discs

Sheet steel housing and square bore



TRV

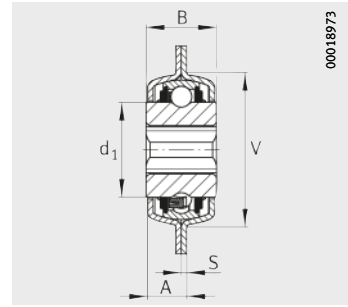

TRV-28X127X42,9

**Dimension table** - Dimensions in mm

Designation	Mass m ≈kg	Dimensions					
		d	L	J	N	S	B
<b>TRV-28X127X42,9-IA02</b>	1,28	<b>28</b>	127	127	13,5	3,4	42,9
<b>TRV-38X140X55,2-IA02</b>	2,5	<b>38</b>	140	140	13,6	4	55,2

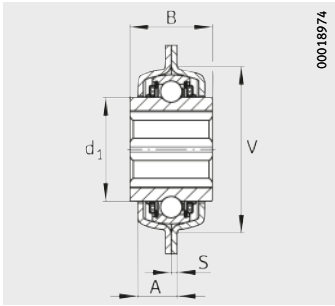

TRV-38X140X55,2

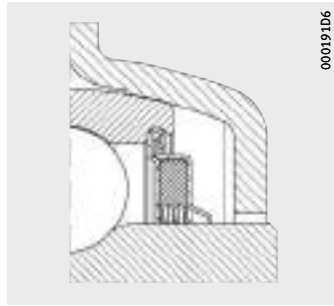

With T seal

			Load carrying capacity Housing	Basic load ratings	
V	A	d <sub>1</sub>		dyn. C <sub>r</sub> N	stat. C <sub>0r</sub> N
95	23,8	57,9	7 700	32 500	20 400
113	26,4	69,77	9 800	43 500	29 000



# Flanged housing units for drums

Two-bolt and four-bolt flanged housing units

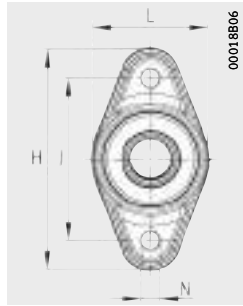

RCJT-25X134X44,6  
RCJT-35X155X39,9

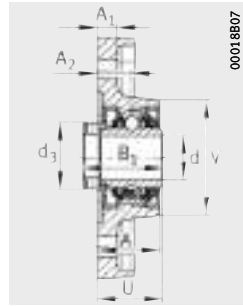

RCJT-25X134X44,6

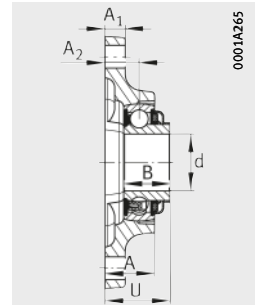

RCJT-35X155X39,9

## Dimension table - Dimensions in mm

Designation	Mass m ≈kg	Dimensions						
		d	L	H	A <sub>1</sub>	N	B	U
IBBU-25X100X42-IA03	1,6	25	–	100	10	M10	25	–
RCJT-25X134X44,6-IA03	0,89	25	70	134	11	11,5	–	36,5
IBBU-35X125X40-IA03	1,83	35	–	125	20	M12	28,4	–
RCJT-35X155X39,9-IA03	1,05	35	92	155	12,5	14	28,4	39,9
RCJ-35X118X39,1-IA03	1,45	35	118	–	12,5	14	37,7	39,9
IBBU-40X143X38,4-IA03	2,91	40	143	–	13	17	38,4	38,4
IBBU-50X143X38,4-IA03	2,5	50	143	–	13	17	38,4	–
TCJY-60X175X73,8-IA03	4	60	175	–	16	18	65,1	73,7
IBBU-60X175X73,8-IA03 <sup>1)</sup>	4,1	60	175	–	16	18	65,1	73,7

<sup>1)</sup> Available by agreement only.

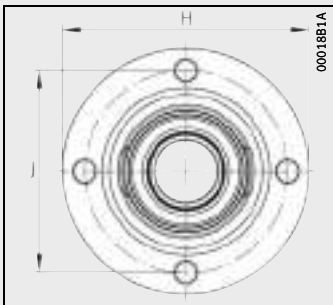

IBBU-25X100X42

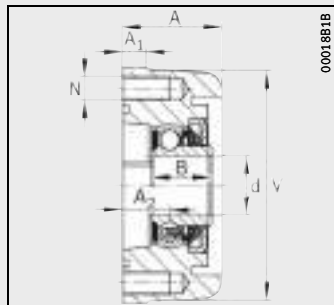

IBBU-25X100X42

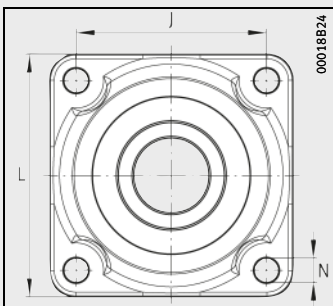

IBBU-40X143X38,4  
IBBU-50X143X38,4

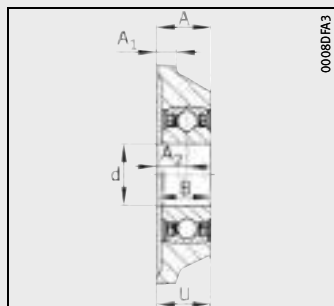

IBBU-40X143X38,4  
IBBU-50X143X38,4

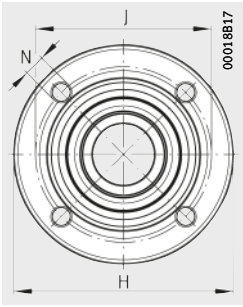

IBBU-35X125X40

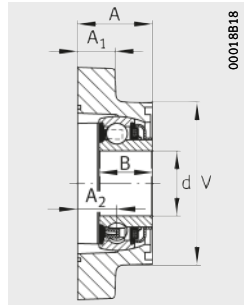

IBBU-35X125X40

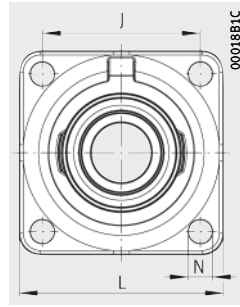

TCJY-60X175X73,8  
RCJ-35X118X39,1

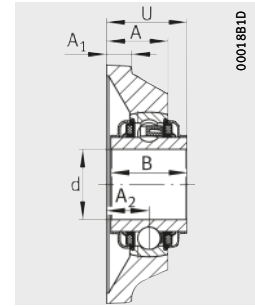

TCJY-60X175X73,8  
RCJ-35X118X39,1

B <sub>1</sub>	J	A <sub>2</sub>	d <sub>3</sub>	A	V	Basic load ratings	
						dyn. C <sub>r</sub> N	stat. C <sub>0r</sub> N
-	82	19,8	-	42	98	14 000	7 800
44,5	99	19	37,5	35	65	14 000	7 800
-	100	21	-	40	88	25 500	15 300
-	130	21	-	30,5	-	25 500	15 300
-	92	21	-	30,5	-	25 500	15 300
-	111	19,2	-	35	-	56 000	45 500
-	111	19,2	-	35	-	56 000	45 500
-	143	34	-	46	150	52 000	36 000
-	143	34	-	49,5	150	79 000	67 000

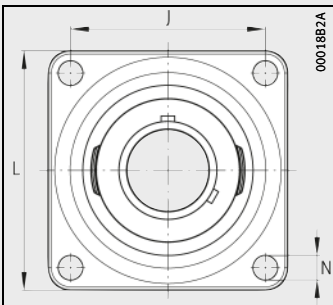

IBBU-60X175X73,8

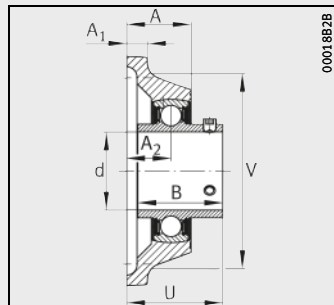

IBBU-60X175X73,8

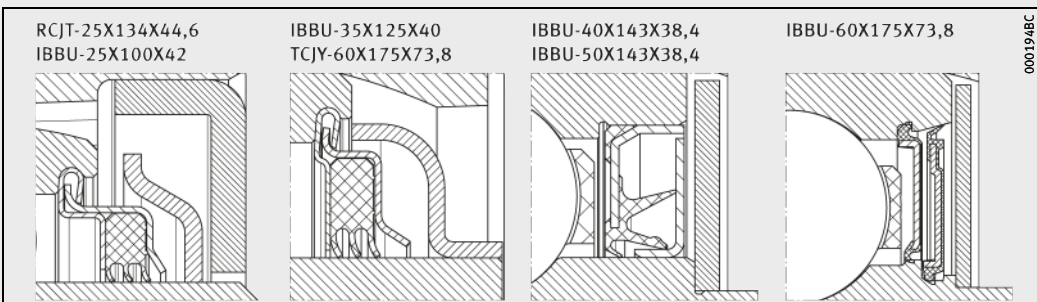

Selection of sealing concepts



# Flanged housing units for harvesters

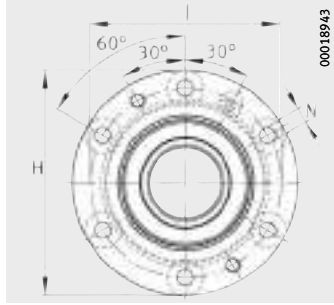

RME, RMEO

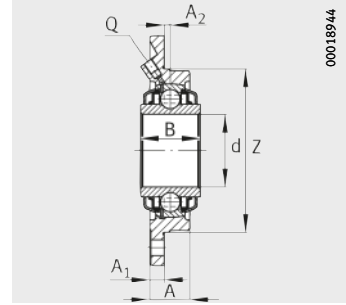

RME, RMEO

## Dimension table - Dimensions in mm

Designation	Mass m ≈ kg	Dimensions				
		d	H	H <sub>1</sub>	A <sub>1</sub>	N
<b>TSHEV-30X150X140-IA04</b>	4	<b>30</b>	140	69,9	60 / 42 <sup>1)</sup>	–
<b>TME-40X150X60-IA04</b>	2,64	<b>40</b>	150	–	10	13
<b>IBBU-42X124X48-IA04</b>	0,71	<b>42</b>	124	–	–	–
<b>RMEO-50X190X49,3-IA04</b>	3,59	<b>50</b>	190	–	12	13
<b>RMEO-55X200X49,2-IA04</b>	4,5	<b>55</b>	200	–	13	13
<b>RMEY-60X173X65,2-IA04</b>	4,1	<b>60</b>	183	–	34	14 / M16 <sup>2)</sup>
<b>RME-60X190X49,3-IA04</b>	3,46	<b>60</b>	190	–	12	13
<b>RMEO-60X217X98,6-IA04</b>	10,12	<b>60</b>	217	–	18	13

1) Base width = 60, head width = 42.

2) Fixing holes: 2×Ø14 and 2×M16.

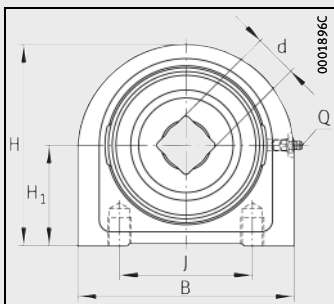

Cast iron housing TSHEV with short base

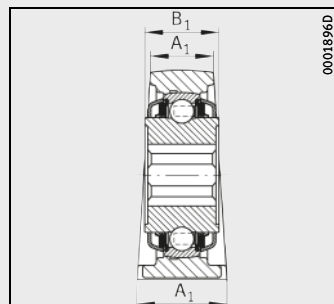

TSHEV



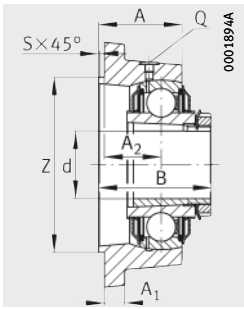

RMEO-60X217X98,6

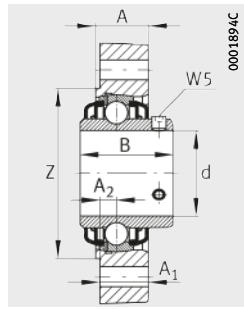

RMEY-60X173X65,2

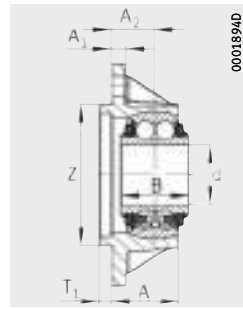

TME-40X150X60

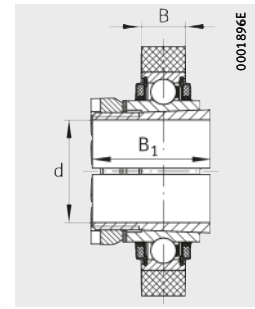

IBBU-42X124X48

								Basic load ratings	
B	B <sub>1</sub>	J	A <sub>2</sub>	Q	A	T <sub>1</sub>	Z	dyn. C <sub>r</sub> N	stat. C <sub>0r</sub> N
150	49,2	92	-	M8×1	-	-	-	52 000	36 000
46	-	119	29	-	45,25	8	94,7	50 000	37 500
18	48	-	-	-	-	-	-	43 000	37 000
49,2	-	160	5	M8×1	33	-	135	62 000	38 000
49,2	-	170	5	M8×1	36	-	145	72 000	44 500
65,1	-	145	11,5	-	37	-	119,5	52 000	36 000
49,2	-	160	5	M8×1	33	-	135	52 000	36 000
100	-	186	50	M8×1	73,5	-	155,5	104 000	68 000

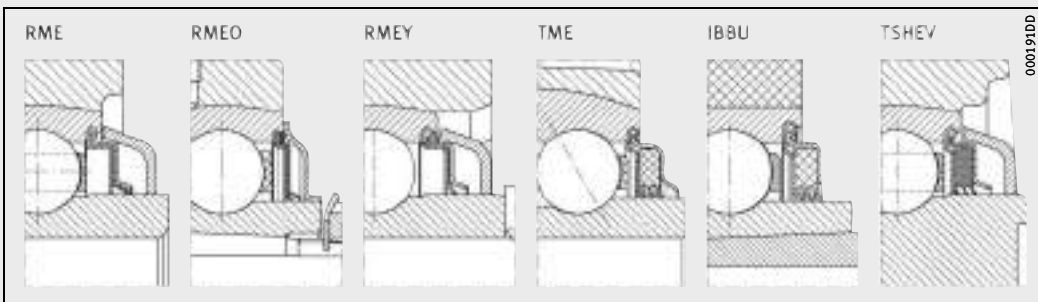

Selection of sealing concepts



## Product overview

## Bearing arrangements for conveying equipment

### Plummer block housing units

Radial insert ball bearing  
with adapter sleeve

PASEA...-IC

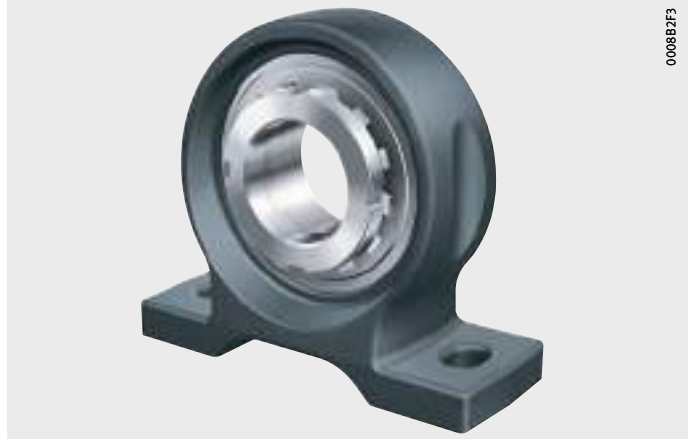

### Take-up housing units

Self-aligning  
deep groove ball bearing  
with bore for fit

PTUE...-IC



### Two-bolt flanged housing units

PCJTZA...-IC



# Bearing arrangements for conveying equipment

**Features** Radial insert ball bearings and housing units are used in the conveying equipment sector predominantly for the transport of materials, parts or passengers.

This involves continuous conveying within transport and logistics systems:

- workpieces
- products in industrial production
- package or luggage conveying systems
- passenger transport by means of lifts and moving stairways.

In order to ensure steady flow of goods and people, these conveying systems place heavy demands on reliable and low-friction functioning of the radial insert ball bearings and housing units fitted. Accordingly, the following products are characterised by low maintenance requirements and high corrosion resistance as well as user-friendly mounting. The units can compensate for static misalignment.

**Location on shaft** The radial insert ball bearings can be located on the shaft by means of an eccentric locking collar or two grub screws in the inner ring. For an alternating direction of rotation and smooth running, a self-aligning deep groove ball bearing can be located on the shaft by means of a fit seat.

The take-up housing unit PTUE..-IC has a bore designed for a fit seat. For high speeds or very high requirements for smooth running, radial insert ball bearings with adapter sleeves are used. Typical areas of application for plummer block housing units PASEA..-IC include glass transport systems in industrial production.

**Anti-corrosion protection** The radial insert ball bearings in two-bolt flanged housing units PCJTZA have a Corrotect coating.

**Sealing** Most conveying equipment is operated in an environment protected against the weather and is subjected to only slight or moderate contamination. As a result, standard seals are absolutely sufficient. Radial insert ball bearings for conveying equipment are therefore sealed by means of seals P or R.

**Lubrication** The radial insert ball bearings are greased and can be relubricated via the holes in the housing.

**Operating temperature** The units are suitable for operating temperatures from  $-20\text{ }^{\circ}\text{C}$  to  $+100\text{ }^{\circ}\text{C}$ .

**Suffixes** Suffixes for available designs: see table.

**Available designs**

Suffix	Description	Design
IC	Design matched to conveying equipment (Industry Conveyors)	Standard



# Housing units for conveying equipment

- Plummer block housing units
- Two-bolt flanged housing units
- Take-up housing units

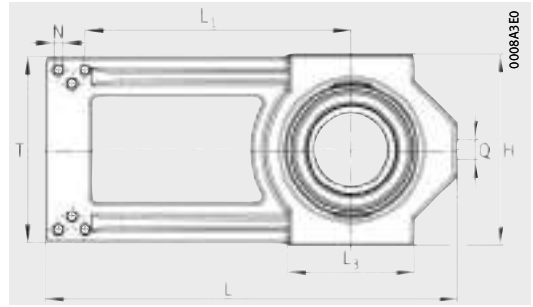

PTUE-55×310×146

**Dimension table** - Dimensions in mm

Designation	Mass m ≈ kg	Dimensions								
		d	H	J	L	L <sub>1</sub>	L <sub>3</sub>	A	A <sub>1</sub>	A <sub>2</sub>
<b>PASEA-35×132×114,2-IC</b>	1,72	<b>35</b>	64,2	100	132	–	–	50	30	–
<b>PCJTZA-35×172×45-IC</b>	1,54	<b>35</b>	172	143,5	105	–	–	30,5	13	20
<b>PTUE-55×310×146-IC</b>	4,1	<b>55</b>	146	–	310	200	95	–	20,5 <sup>+0,2</sup>	39

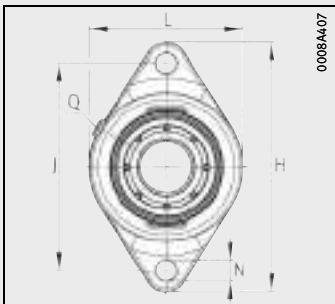

PCJTZA-35×172×45

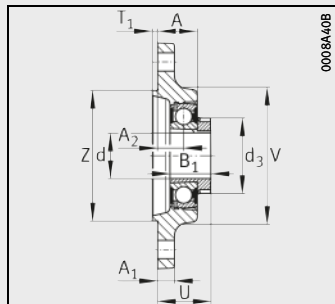

PCJTZA-35×172×45

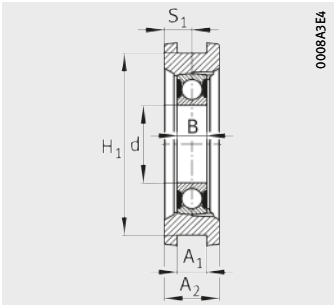

PTUE-55×310×146

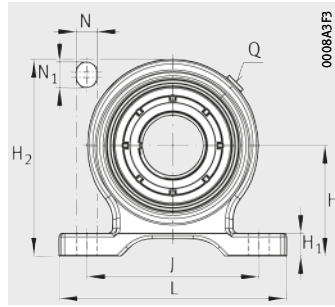

PASEA-35×132×114,2

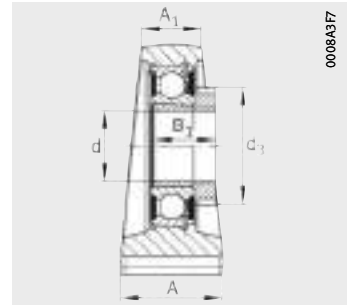

PASEA-35×132×114,2

														Basic load ratings	
H <sub>1</sub>	H <sub>2</sub>	N	N <sub>1</sub>	B	B <sub>1</sub>	S <sub>1</sub>	T	T <sub>1</sub>	U	V	Z	Q	d <sub>3</sub>	dyn. C <sub>r</sub>	stat. C <sub>0r</sub>
											h8		max.	N	N
13,2	114,2	12	17	–	31	–	–	–	–	–	–	R <sub>p</sub> 1/8	58	32 500	19 800
–	–	14	–	–	31	–	–	4	41	105	100	R <sub>p</sub> 1/8	58	32 500	19 800
129,5	–	M8	–	21	–	19,5	140	–	–	–	–	13	–	43 500	29 000



# Product overview Bearing arrangements for textile machinery

## Radial insert ball bearings With adapter sleeve

SH



## Plummer block housing units

RASEY..-IT

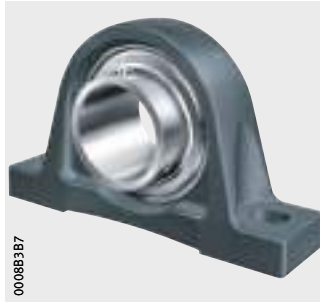

## Two-bolt or three-bolt flanged housing units

LCJT..-IT



LCFTRY..-IT



# Bearing arrangements for textile machinery

**Features** Whether it is spinning or weaving, finishing or processing, modern textile machines are highly automated and must run with high material throughput and without malfunctions, right around the clock.

The decisive features of bearing arrangements for textile machinery are:

- high precision
- low friction
- energy efficiency
- ease of mounting
- ease of maintenance
- reliability.

**Further information** ■ Bearing arrangements for textile machinery based on various products are compiled in publication TMB, Rolling Bearings for Textile Machinery.  
■ Download and ordering: <http://medien.schaeffler.de>.

## Radial insert ball bearings

The radial insert ball bearing SH30-2BRS-AH05 is used to support the delivery shaft in texturing machines, *Figure 1*. It is characterised by particularly low running friction and smooth running. Location on the shaft is by means of an adapter sleeve and locknut.



*Figure 1*  
Radial insert ball bearings  
in texturing machinery

**Sealing** The BRS seal integrated in the bearing acts as a gap seal and ensures not only low-friction running but also good sealing action due to the elastic rim in the outer ring slot.

**Lubrication** The radial insert ball bearing SH30-2BRS-AH05 is greased by means of a barium complex soap grease L178 and lubricated for life.



# Bearing arrangements for textile machinery

## Plummer block housing units

The plummer block housing unit RASEY70..-IT is used as a bearing arrangement for dryer rolls, *Figure 2*. The dryer rolls are driven by means of flat belts. The locating bearing is arranged on the side with the belt pulley. Location on the shaft is by means of two grub screws. On the non-locating bearing side, the unit is used as a non-locating bearing. A grub screw on the radial insert ball bearing engages in a slot on the shaft without clamping against the shaft. As a result, the shaft can be displaced axially in the inner ring. Static misalignments can be compensated by the self-alignment facility of the cast iron housing units.

- ① Non-locating bearing RASEY70
- ② Locating bearing RASEY70

*Figure 2*  
Dryer roll  
for removing residual moisture  
from processed material



### Sealing

Sealing is carried out by means of an R seal, as is typical for a radial insert ball bearing.

### Lubrication

The unit is relubricated via holes in the housing.



**Flanged housing units** Two-bolt flanged housing units are used for the bearing arrangement of the straightening shaft in a straightening machine. In order to prevent corrosion, the entire unit has a Corrotect coating. Location on the shaft is by means of an eccentric locking collar. Three-bolt flanged housing units with a corrosion-resistant steel end cap are specially matched to use in ink cylinders. The housings are made corrosion-resistant by means of an iron-zinc coating.

**Sealing** Sealing with reduced friction is ensured by means of labyrinth seals.

**Lubrication** The flanged housing units can be relubricated by means of a lubrication nipple.

**Anti-corrosion protection** The radial insert ball bearing and eccentric locking collar have a Corrotect coating.

**Operating temperature** Radial insert ball bearings and housing units for textile machinery are suitable for a temperature range from  $-20\text{ }^{\circ}\text{C}$  to  $+100\text{ }^{\circ}\text{C}$ . In the case of the plummer block housing unit RASEY-70 $\times$ 260 $\times$ 156-IT, the upper limit is  $+160\text{ }^{\circ}\text{C}$ .

**Suffixes** Suffixes for available designs: see table.

**Available designs**

Suffix	Description	Design
IT	Design matched to textile machinery (Industry Textile)	Standard



# Radial insert ball bearings and units for textile machinery

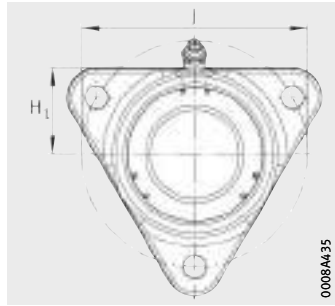

LCFTRY-30×116×56-IT

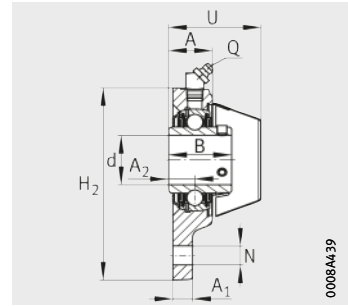

LCFTRY-30×116×56-IT

**Dimension table** - Dimensions in mm

Designation	Mass m ≈ kg	Dimensions						
		d	H	J	L	A	A <sub>1</sub>	A <sub>2</sub>
<b>LCFTRY-30×116×56-IT</b>	1,11	<b>30</b>	–	116	–	26,6	12	15,9
<b>LCJT-45×180×59,1-IT</b>	2,2	<b>45</b>	180	148,5	111	35	13	24
<b>RASEY-70×260×156-IT</b>	5,9	<b>70</b>	79,4	203	260	65	44	–

**Dimension table** - Dimensions in mm

Designation	Mass m ≈ kg	Dimensions						Limiting speed <sup>1)</sup> n <sub>G</sub> grease min <sup>-1</sup>	Basic load ratings		Factor <sup>2)</sup> f <sub>0</sub>
		d	B	B <sub>1</sub>	S	D <sub>sp</sub>	C		dyn. C <sub>r</sub> N	stat. C <sub>0r</sub> N	
<b>SH30-2BRS-AH05</b>	0,26	<b>30</b>	16	31	8	62	16	17 900	18 900	11 300	13,8

1) Preferably for shafts of tolerance classes h6 @ h11 @.

2) Factor f<sub>0</sub> for determining equivalent bearing load, see table, page 40.

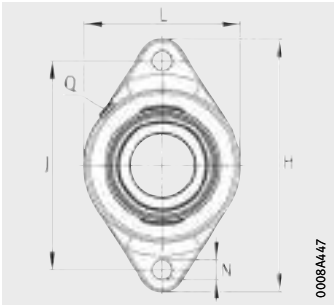

LCJT-45×180×59,1-IT

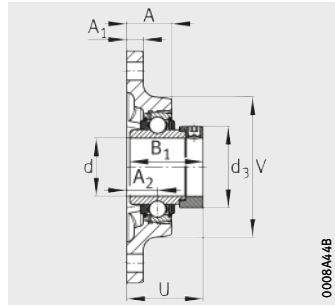

LCJT-45×180×59,1-IT

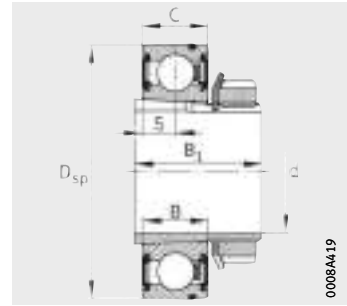

SH30-2BRS-AH05

N	N <sub>1</sub>	H <sub>1</sub>	H <sub>2</sub>	B	B <sub>1</sub>	S <sub>1</sub>	U	V	Q	d <sub>3</sub>	Basic load ratings	
											dyn. C <sub>r</sub> N	stat. C <sub>0r</sub> N
11	-	44	117	38,1	-	-	56	-	R <sub>p</sub> 1/8	-	19 500	11 300
14	-	-	-	-	56,5	-	59,1	111	R <sub>p</sub> 1/8	63	32 500	20 400
22	28	27,5	156	74,6	-	44,4	-	-	R <sub>p</sub> 1/8	-	62 000	44 000

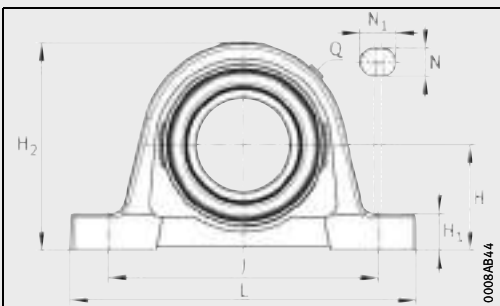

RASEY-70×260×156-IT

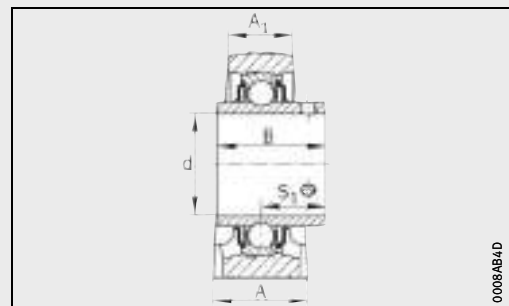

RASEY-70×260×156-IT



# Product overview **Flanged housing units for the food industry**

## **Two-bolt flanged housing units**

Eccentric locking collar  
With Corrotect coating

PCSTK



Grub screws in inner ring  
VA steel

RCSTKY...-VA



## **Four-bolt flanged housing units**

Eccentric locking collar  
With Corrotect coating

PCSK



Grub screws in inner ring  
VA steel

RCSKY...-VA



# Flanged housing units for the food industry

<b>Features</b>	<p>Flanged housing units are ready-to-fit units comprising a two-piece, two-bolt or four-bolt housing fitted with a radial insert ball bearing. The bearings are particularly easy to mount and compensate static shaft misalignment. With regular relubrication, misalignments of up to <math>\pm 2,5^\circ</math> are possible.</p> <p>The flanged housing units are resistant to moisture, contaminated water and weakly alkaline or weakly acidic cleaning agents. They are also resistant to mould and fungal attack.</p> <p>The ends of shafts can be covered by means of bearing end caps KASK, giving protection against injury due to the rotating shaft. The bearing end caps, which are ordered separately, also protect the bearing against contamination, see page 435.</p>
<b>Location on shaft</b>	<p>The radial insert ball bearings are located on the shaft by means of an eccentric locking collar or two grub screws. They are preferably suitable for shafts up to tolerance class h9 <math>\text{\textcircled{E}}</math>.</p>
<b>Tightening torques</b>	<p>The tightening torques for the grub screws must be observed, see table, page 130.</p>
<b>Location on adjacent construction</b>	<p>The flanged housings are of a two-piece design and comprise a polypropylene flange combined with a corrosion-resistant, high grade steel flange. The housing is screw mounted on the adjacent construction.</p>
<b>Fixing screws</b>	<p>The screw connection should be designed in accordance with VDI 2230; friction coefficient <math>\mu = 0,12</math> (90%).</p> <p>Screws of grade 8.8 or better can be used for fixing. The maximum tightening torques applicable to this screw grade must not be exceeded even if screws of a higher grade are used. In principle, we recommend that the screw connection should only be tightened to 70% of the values stated in the standard.</p> <p>For fixing, hexagonal socket head screws in accordance with DIN EN ISO 4762 or hexagonal socket head screws with a coarse pitch full thread in accordance with DIN EN ISO 4017 should be used. The screws should be combined as a minimum with a washer in accordance with DIN EN ISO 7089 or DIN EN ISO 7090.</p> <p>Screws and accessories for location are not included in the delivery. All screws and other accessories used for location should be in the corrosion-resistant VA design.</p>



# Flanged housing units for the food industry

**Anti-corrosion protection** The radial insert ball bearing and eccentric locking collar have a Corrotect coating. In the case of flanged housing units with the suffix VA, the bearing rings and rolling elements are made from corrosion-resistant, high alloy rolling bearing steel.

**Sealing** The flanged housing units PCSTK and PCSK with eccentric locking collar have zinc plated P seals on both sides.  
The flanged housing units RCSTKY..-VA and RCSKY..-VA with grub screws have RSR seals and additional outer filnger shields on both sides.

**Lubrication** The radial insert ball bearings GRAE..-XL-NPP-B-FA107/125 are greased by means of a barium complex soap grease KP2N-20 with a mineral oil base in accordance with DIN 51825.  
The radial insert ball bearings SUC are greased by means of the grease FM222 of grease class KPF2K-20 in accordance with DIN 51825.

**Relubrication** The housings have a threaded hole with a Whitworth pipe thread  $R_p^{1/8}$  in accordance with DIN 3858 and DIN EN ISO 228-1 for conventional lubrication connectors. The hole is closed off using a plastic plug.  
The radial insert ball bearings GRAE can be relubricated by means of two lubrication holes offset by 180° in the outer ring. In the case of radial insert ball bearings SUC, the two lubrication holes are offset by 120°.

**Operating temperature** Housing units with bearing end caps are suitable for operating temperatures from -20 °C to +80 °C.  
Housing units without bearing end caps are suitable for operating temperatures from -20 °C to +100 °C.

**Suffixes** Suffixes for available designs: see table.

## Available designs

Suffix	Description	Design
FA107	Bearing with lubrication holes on the locating side	Standard
FA125	With Corrotect coating, corrosion-resistant	
VA	Corrosion-resistant design made from high alloy rolling bearing steel	

**Design and safety guidelines**  
**Axial load carrying capacity**

The axial load carrying capacity is restricted by the load carrying capacity  $C_G$  of the housing and the mounting connection between the shaft and inner ring, *Figure 1*.

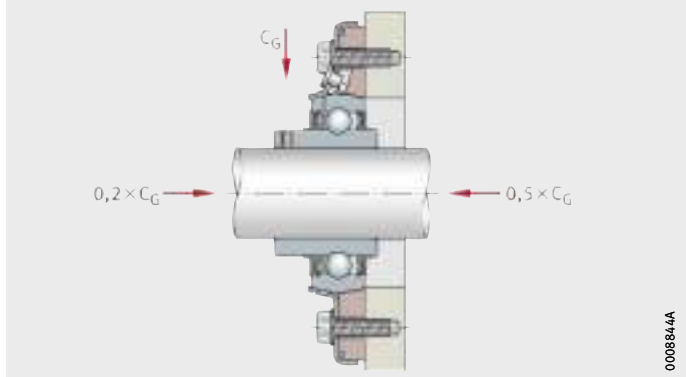

$C_G$  = load carrying capacity of housing

*Figure 1*  
 Axial load carrying capacity of housing

**Bearing end caps**

The ends of shafts can be covered using bearing end caps made from acrylonitrile styrene acrylate copolymer (ASA), see table and *Figure 2*. The end caps are suitable for temperatures from  $-20\text{ }^{\circ}\text{C}$  to  $+80\text{ }^{\circ}\text{C}$ . They protect against injury due to rotating shafts and also protect the bearings against contamination.

The end caps have a breakout section that allows the shaft to pass through if necessary.

Bearing end caps are accessories and must always be ordered separately.

**End caps**

Designation	Dimensions				
	d	D	H	L	E max.
<b>KASK08-S</b>	30	84,6	35	44,8	40,05
	40				

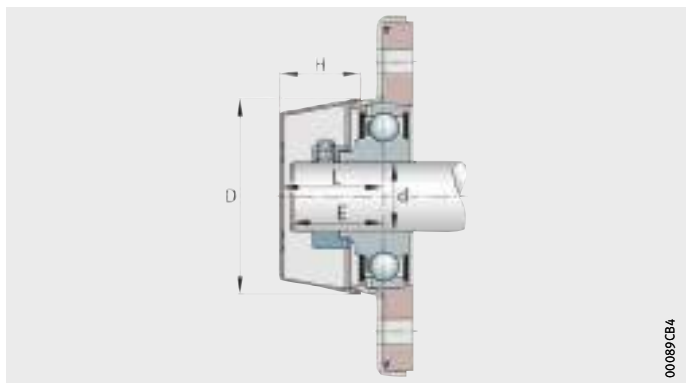
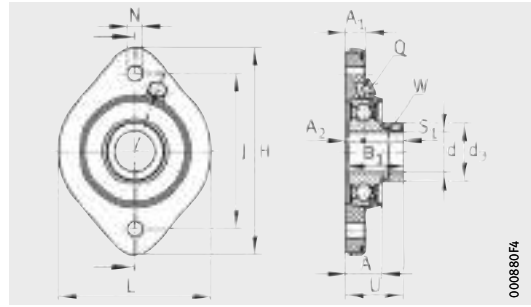

*Figure 2*  
 Housing unit with bearing end cap



# Flanged housing units for the food industry

Two-bolt and four-bolt flanged housing units  
Corrosion-resistant



PCSTK

**Dimension table** - Dimensions in mm

Designation <sup>1)</sup>	Housing	Radial insert ball bearing	Mass m ≈ kg	Dimensions						
				d	H	J	L	A	A <sub>1</sub>	A <sub>2</sub>
<b>PCSK30-208</b>	GEH80-CSK	GRAE30-208-XL-NPP-B-FA107/125	0,94	<b>30</b>	121	82	110	27	14,5	12
<b>PCSTK30-208</b>	GEH80-CSTK	GRAE30-208-XL-NPP-B-FA107/125	0,93	<b>30</b>	156	117	115	28	15,5	13
<b>PCSK40</b>	GEH80-CSK	GRAE40-XL-NPP-B-FA107/125	0,93	<b>40</b>	121	82	110	27	14,5	12
<b>PCSTK40</b>	GEH80-CSTK	GRAE40-XL-NPP-B-FA107/125	0,92	<b>40</b>	156	117	115	28	15,5	13
<b>RCSKY40-VA</b>	GEH80-CSK	SUC208	0,93	<b>40</b>	121	82	110	27	14,5	12
<b>RCSTKY40-VA</b>	GEH80-CSTK	SUC208	0,93	<b>40</b>	156	117	115	28	15,5	13

<sup>1)</sup> Fixing screws in accordance with DIN EN ISO 4762 are not included in the scope of delivery.  
Note maximum tightening torque  $M_A = 50 \text{ Nm}$ .

<sup>2)</sup> Tightening torque for grub screws, see table, page 130.



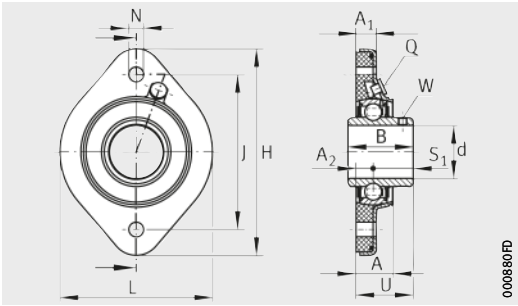

RCSTKY..-VA

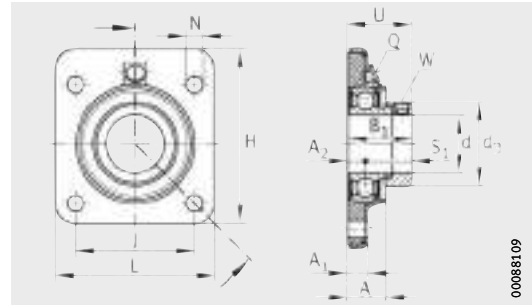

PCSK

N	B	B <sub>1</sub>	U	S <sub>1</sub>	Q	d <sub>3</sub> max.	Width across flats <sup>2)</sup> W	Load carrying capacity Housing C <sub>0rG</sub> N	Basic load ratings		Fatigue limit load C <sub>ur</sub> N
									dyn. C <sub>r</sub> N	stat. C <sub>0r</sub> N	
11	-	42,1	42,1	31,05	Rp <sup>1</sup> / <sub>8</sub>	44	4	10 000	34 500	19 800	1 010
11	-	42,1	44	31,05	Rp <sup>1</sup> / <sub>8</sub>	44	4	6 000	34 500	19 800	1 010
11	-	43,8	44,8	32,8	Rp <sup>1</sup> / <sub>8</sub>	58	5	10 000	34 500	19 800	1 010
11	-	43,8	45,8	32,8	Rp <sup>1</sup> / <sub>8</sub>	58	5	6 000	34 500	19 800	1 010
11	49,2	-	42,2	30,2	Rp <sup>1</sup> / <sub>8</sub>	-	4	10 000	31 500	18 900	910
11	49,2	-	43,2	30,2	Rp <sup>1</sup> / <sub>8</sub>	-	4	6 000	31 500	18 900	910

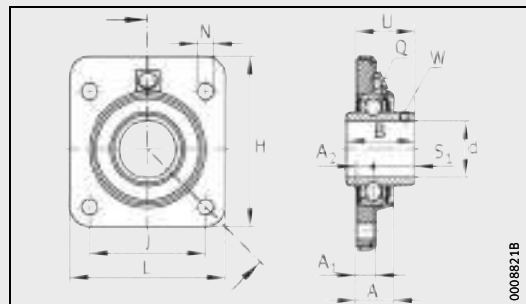

RCSKY..-VA



## Product overview Take-up housing units for ventilators

**Hanger bearing**  
Take-up housing unit

PGVE..-XL, RGVE..-XL, RGVEA..-XL



00044F65

# Take-up housing units for ventilators

## Features

The single piece take-up housing units PGVE..-XL, RGVE..-XL, RGVEA..-XL for ventilators are hanger bearings with housings made from flake graphite cast iron. They have three fixing holes with a pitch of  $t = 120^\circ$ , *Figure 1*. Relubrication is carried out via a conventional lubrication nipple in accordance with DIN 71412.

Location is carried out by means of eccentric locking collar, grub screws, adapter sleeve or drive slot, see tables.

The outer ring has a spherical outside surface. In combination with a housing matched to the design, the units can compensate for possible misalignments of the shaft.

$t = 120^\circ$

*Figure 1*  
Take-up housing unit  
as hanger bearing for ventilators

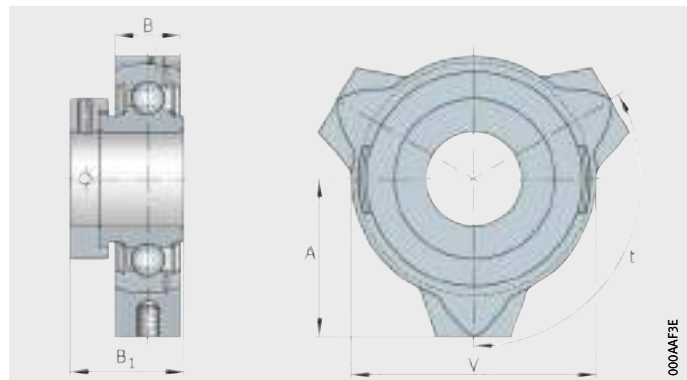





## Possible combinations

Radial insert ball bearing		Take-up housing
		 000AAFB
Designation		<b>GVE</b>
Shaft diameter d		
<b>GRAE..-XL-NPP-B</b> 12 mm – 60 mm		<b>PGVE..-XL</b> Available by agreement
<b>GE..-XL-KRR-B</b> 17 mm – 120 mm		<b>RGVE..-XL</b> Available by agreement
<b>GE..-XL-KTT-B</b> 20 mm – 80 mm		<b>TGVE..-XL</b> Available by agreement
<b>GE..-XL-KLL-B</b> 20 mm – 50 mm		<b>LGVE..-XL</b> Available by agreement



# Take-up housing units for ventilators

## Possible combinations (continued)

Spannlager	Take-up housing  0004AF5B
Designation Shaft diameter d	<b>GVE</b>
<b>GLE..-XL-KRR-B</b> 20 mm – 70 mm 	<b>RGVEL..-XL</b> Available by agreement
<b>GSH..-XL-2RSR-B</b> 20 mm – 50 mm 	<b>RGVEA..-XL</b> Available by agreement
<b>GAY..-XL-NPP-B</b> 12 mm – 60 mm 	<b>PGVEY..-XL</b> Available by agreement
<b>GYE..-XL-KRR-B</b> 12 mm – 90 mm 	<b>RGVEY..-XL</b> Available by agreement



**FAG**



## Mounting and maintenance



# Mounting and maintenance

	Page
<b>Features</b>	
Products and services .....	589
Industrial Aftermarket .....	590
Sales partners .....	590
Mounting Toolbox, mounting made easy.....	591
<b>Product overview</b>	
Mounting.....	592
<b>Features</b>	
Mounting.....	593
Mounting services .....	593
Hook and pin wrenches .....	594
<b>Product overview</b>	
Lubrication .....	596
<b>Features</b>	
Lubrication .....	597
Services .....	597
Lubricants.....	597
Lubrication devices .....	598

# Products and services

**Features** Within its Industrial Service concept, Schaeffler offers high quality products, services and training, *Figure 1*.

**Portfolio** This chapter gives an overview of the portfolio:

- Mounting
- Lubrication
- Condition Monitoring
- Reconditioning.

The employees of Schaeffler worldwide will be pleased to help you select the ideal products, services and training courses, *Figure 1*.



*Figure 1*  
Portfolio



# Products and services

## Industrial Aftermarket

Schaeffler Industrial Aftermarket (IAM) is responsible for replacement parts and service business for end customers and sales partners in all significant industrial sectors. On the basis of innovative solutions, products and services relating to rolling and plain bearings, the service function of Schaeffler Industrial Aftermarket offers a comprehensive portfolio that covers all phases in the life-cycle of the bearing and takes account of the total costs (TCO).

The aim is to help customers save on maintenance costs, optimise plant availability and avoid unforeseen machine downtime. Schaeffler Industrial Aftermarket offers each customer an individual concept solution.

Schaeffler has centres of competence all around the world. This means we can provide customers worldwide with products, services and training quickly and professionally. All service employees worldwide undergo a comprehensive training programme and are audited regularly by officially certified specialists. This ensures that services throughout the world conform to a uniformly high standard of quality.

## Sales partners

In order to achieve this objective, we have established a network of Schaeffler sales partners. This network makes it possible to service all end customers worldwide to the same high level of competence and is thus the optimum delivery strategy.

At [www.schaeffler.de/sales](http://www.schaeffler.de/sales), you can find the addresses of all the sales partners certified by Schaeffler.



## Mounting Toolbox, mounting made easy

The Schaeffler Mounting Toolbox, *Figure 2*, brings together valuable knowledge relating to mounting and dismounting. In individual video sequences, the service experts present step by step the points that must be paid close attention for correct mounting, lubrication and alignment.

The interface is a “Virtual Plant” and offers the user easy, rapid navigation. With just a few clicks of the mouse, it is possible to gain an overview of the tools and accessories as well as to select individual video sequences. Internet access is all that is needed to enter the “Virtual Plant” and watch the Schaeffler fitting personnel at work.

<http://mtb.schaeffler.de>

*Figure 2*  
Mounting Toolbox



# Product overview **Mounting**

## Hook and pin wrenches

Hook wrench

LOCKNUT-HOOK



LOCKNUT-HOOK-KM0-16-SET



Jointed hook wrench

Jointed pin wrench

LOCKNUT-FLEXIHOOK



LOCKNUT-FLEXIPIN



# Mounting

**Features** The Schaeffler industrial service experts offer mounting services for rolling and plain bearings that are applicable across industrial sectors. They have detailed knowledge and extensive experience in all industrial sectors.

The mounting personnel in the Industrial Service function are trained and skilled personnel who can provide reliable, rapid and competent assistance. The services are provided either at the customer's location or in the Schaeffler workshop facilities.

These mechanical tools are designed for the mounting and dismounting of bearings. The mounting forces are transmitted by the form fit effect.

**Further information** ■ Detailed information on mechanical tools can be found in Catalogue IS 1, Mounting and Maintenance of Rolling Bearings.

**Mounting services** The mounting services, *Figure 1*, include:

- mounting and dismounting of rolling bearings of all types
- approval inspection of adjacent parts (shafts and housings)
- measurement and production inspection of tapered shaft seats, together with provision of the necessary measuring equipment
- maintenance and inspection of bearing arrangements
- support in achieving optimum mounting operations
- use of modern mounting tools, such as heating by means of versatile medium frequency technology
- design and manufacture of special tools.



*Figure 1*  
Mounting services

**Advantages** The mounting services give the following advantages:

- extended bearing life
- considerable cost reductions
- less unplanned downtime
- increased plant availability
- correct use of rolling bearings.

**Further information** ■ Enquiries:  
tel. +49 9721 91-3142, fax +49 9721 91-3639.



# Mounting

## Hook and pin wrenches

These wrenches can be used for the mounting and dismounting of small bearings on shaft seats, adapter sleeves or withdrawal sleeves. In addition to the sizes named here, other sizes are available by agreement.

### Hook wrench

The hook wrench LOCKNUT-HOOK can be used to dismount not only bearings but also withdrawal sleeves with the aid of extraction nuts. Hook wrenches are available in sizes suitable for locknuts KM to KM40, suitable for diameters from 16 mm to 245 mm.

Ordering example  
Ordering designation

Hook wrench, suitable for locknuts KM18, KM19 and KM20  
**LOCKNUT-HOOK-KM18-20**

Hook wrenches can also be ordered as a set. The set comprises ten hook wrenches of sizes KM0 to KM16 in a roll-up pouch and is suitable for diameters from 16 mm to 100 mm.

Ordering example  
Ordering designation

Set of ten hook wrenches  
**LOCKNUT-HOOK-KM0-16-SET**

### Jointed hook wrench

The joint allows one hook wrench LOCKNUT-FLEXIHOOK to be used for the mounting or dismounting of locknuts of various sizes. Jointed hook wrenches are available in sizes for locknuts KM1 to KM36, suitable for diameters from 20 mm to 230 mm.

Ordering example  
Ordering designation

Jointed hook wrench, suitable for locknuts KM14 to KM24  
**LOCKNUT-FLEXIHOOK-KM14-24**

### Jointed pin wrench

The jointed pin wrench LOCKNUT-FLEXIPIN is hooked into radially arranged holes in the nut. Jointed pin wrenches are available in sizes for locknuts AM15 to AM90, suitable for diameters from 35 mm to 155 mm.

Ordering example  
Ordering designation

Jointed pin wrench, suitable for precision locknuts AM35 to AM60  
**LOCKNUT-FLEXIPIN-AM35-60**

### Further information

- For detailed information, see TPI 216, FAG Tools for Mechanical Mounting and Dismounting of Rolling Bearings.
- Enquiries:  
industrial-services@schaeffler.com, +49 2407 9149-66.



# Product overview    Lubrication

## Arcanol greases

ARCANOL



## Lubricators

CONCEPT2



## Lubrication system

CONCEPT8



# Lubrication

**Features** In more than half of all cases, inadequate lubrication is the cause of unplanned machine downtime. The life of machine elements undergoing swivel, rotary or linear motion can be significantly extended by the use of greases appropriate to the different operating and environmental conditions as well as the definition of and adherence to lubrication intervals and quantities.

**Services** Services relating to lubrication include:

- selection of lubricants and lubrication systems
- preparation of lubrication and maintenance plans
- lubrication point management
- consultancy on lubricants
- lubricant investigations and tests.

**Advantages** The Schaeffler lubrication service helps to:

- prevent failures involving components undergoing swivel, rotary or linear motion
- increase productivity
- reduce lubrication costs.

**Lubricants** An extensive selection of high quality Arcanol greases is available. Several greases were specially tested and selected for use in rolling bearings, see table. For advice on selection, please consult the Schaeffler engineering service.

## Greases recommended for radial insert ball bearings

Designation	Thickener	Base oil viscosity at +40 °C mm <sup>2</sup> /s	Consistency NLGI	Operating temperature °C	
				over	incl.
<b>MULTITOP</b>	Lithium soap	≧ ISO VG 68	2	-40	+140
<b>MULTI2</b>	Lithium soap	≧ ISO VG 68	2	-30	+120
<b>MULTI3</b>	Lithium soap	≧ ISO VG 68	3	-30	+120
<b>TEMP90</b>	Mixed thickener	≧ ISO VG 100	2	-30	+140
<b>TEMP110</b>	Lithium complex	≧ ISO VG 68	2 – 3	-40	+160
<b>TEMP120</b>	Polycarbamide	≧ ISO VG 460	2	-30	+180
<b>TEMP200</b>	PTFE	≧ ISO VG 220 – 460	2	-30	+250
<b>FOOD2</b>	Aluminium complex	≧ ISO VG 100	2	-30	+120



# Lubrication

## Lubrication devices

Lubricators and lubrication systems automatically provide rolling bearings with the correct quantity of lubricant. This prevents the most frequent cause of rolling bearing failure: inadequate or incorrect lubrication. Approximately 90% of bearings are lubricated with grease. Relubrication with the correct quantity of grease at the appropriate intervals gives a significant increase in the life of bearings.

For manual relubrication, grease guns are suitable.

## Further information

■ For information on products for the supply of lubricant, see Catalogue IS 1, Mounting and Maintenance of Rolling Bearings.

## Automatic relubrication devices

Automatic relubrication devices convey fresh grease in the defined quantity at the correct time to the contact points of the rolling bearing.

The devices adhere to the lubrication and maintenance intervals and prevent undersupply or oversupply of grease. Plant downtime and maintenance costs are reduced as a result.

The relubrication devices are matched to the bearing position. They have a wide range of applications, for example in electric motors, gearboxes, pumps, compressors and fans, in linear systems, conveying equipment or machine tools.

## Lubricator CONCEPT2

This lubricator of protection class IP54 has a very compact design. It has one or two pump bodies that can be individually controlled, depending on the design. This means it can supply one or two lubrication points with lubricant. LC units are available in the size 250 cm<sup>3</sup>. The lubricator is supplied with voltage either from a battery or via a mains power pack, see table, page 599. It can work independently or can be optionally controlled by an external control system.



- Advantages** The advantages of the lubricator are as follows:
- easy operation and good overview
  - supply of up to two lubrication points
  - facility for setting different lubrication intervals for each lubrication point
  - supply of set lubricant quantity independent of temperature
  - counterpressure measurement up to the lubrication point
  - reliable piston pump as delivery pump
  - low ongoing maintenance costs
  - favourable price/performance ratio
  - operating temperature from –20 °C to +70 °C
  - battery or mains operation (DC 24 V) possible
  - pressure build-up to 50 bar (mains operation) or 30 bar (battery operation)
  - differentiated alarm messages
  - simple coupling with machine operation possible
  - suitable for control via an external control system.

**Available lubricators  
CONCEPT2**

Designation	Design
<b>CONCEPT2-1P</b>	Battery version with one outlet
<b>CONCEPT2-2P</b>	Battery version with two outlets
<b>CONCEPT2-1P-24VDC</b>	24-V version with one outlet
<b>CONCEPT2-2P-24VDC</b>	24-V version with two outlets

**Available LC units**

Designation	
<b>ARCALUB-C2.LC250-MULTITOP</b>	<b>ARCALUB-C2.LC250-TEMP90</b>
<b>ARCALUB-C2.LC250-MULTI2</b>	<b>ARCALUB-C2.LC250-TEMP110</b>
<b>ARCALUB-C2.LC250-LOAD150</b>	<b>ARCALUB-C2.LC250-TEMP120</b>
<b>ARCALUB-C2.LC250-LOAD220</b>	<b>ARCALUB-C2.LC250-TEMP200</b>
<b>ARCALUB-C2.LC250-LOAD400</b>	<b>ARCALUB-C2.LC250-SPEED2,6</b>
<b>ARCALUB-C2.LC250-LOAD460</b>	<b>ARCALUB-C2.LC250-MOTION2</b>
<b>ARCALUB-C2.LC250-LOAD1000</b>	<b>ARCALUB-C2.LC250-FOOD2</b>
–	<b>ARCALUB-C2.LC250-CLEAN-M</b>

**Further information** LC units are also available by agreement with other greases.



# Lubrication

## Lubrication system CONCEPT8

This single-point and multi-point lubrication system offers high flexibility. It has one, two, three or four pump bodies that can be individually controlled, depending on the design. Each pump body has two outlets and, as a result, up to eight lubrication points can be flexibly provided with the required quantity of lubricant in the correct lubrication interval using just one lubrication system.

The lubrication system CONCEPT8 is designed for a wide variety of operating conditions. Designs for linear systems, the use of oils as lubricant or with an internal heating facility are also available, see table Available lubrication systems, page 601.

Lubricant cartridges (LC units) provide the device with lubricant, see table Available LC units, page 601. LC units are available in the size 800 cm<sup>3</sup>.

The lubrication system is supplied with voltage from a mains power pack. Coupling with machine operation is possible if the voltage supply to machine and lubrication system is coupled, then the relubrication interval will always be dependent on the number of operating hours.

## Advantages

The advantages of the lubrication system are as follows:

- easy operation and good overview
- suitable for oil and grease up to NLGI 3
- supply of up to eight lubrication points
- supply of set lubricant quantity independent of temperature
- counterpressure measurement up to the lubrication point
- reliable piston pump as delivery pump
- favourable price/performance ratio
- operating temperature from -20 °C to +70 °C
- facility for setting different lubrication intervals and lubricant quantities for each pump body
- low operating voltage of DC 24 V
- pressure build-up to 70 bar
- differentiated alarm messages
- simple coupling with machine operation possible
- suitable for control via an external control system.

**Available lubrication systems  
CONCEPT8**

Designation	
CONCEPT8-1P	CONCEPT8-1P-CC
CONCEPT8-2P	CONCEPT8-2P-CC
CONCEPT8-3P	CONCEPT8-3P-CC
CONCEPT8-4P	CONCEPT8-4P-CC
CONCEPT8-1P-LIN	CONCEPT8-1P-OIL
CONCEPT8-2P-LIN	CONCEPT8-2P-OIL
CONCEPT8-3P-LIN	CONCEPT8-3P-OIL
CONCEPT8-4P-LIN	CONCEPT8-4P-OIL

LIN = for linear applications  
 CC = with internal heating facility  
 OIL = oil version

**Available LC units**

Designation	
ARCALUB-C8.LC800-MULTITOP	ARCALUB-C8.LC800-TEMP90
ARCALUB-C8.LC800-MULTI2	ARCALUB-C8.LC800-TEMP110
ARCALUB-C8.LC800-MULTI3	ARCALUB-C8.LC800-TEMP120
ARCALUB-C8.LC800-LOAD150	ARCALUB-C8.LC800-TEMP200
ARCALUB-C8.LC800-LOAD220	ARCALUB-C8.LC800-SPEED2,6
ARCALUB-C8.LC800-LOAD400	ARCALUB-C8.LC800-VIB3
ARCALUB-C8.LC800-LOAD460	ARCALUB-C8.LC800-MOTION2
ARCALUB-C8.LC800-LOAD1000	ARCALUB-C8.LC800-FOOD2
–	ARCALUB-C8.LC800-CLEAN-M

**Further information**

- LC units are also available by agreement with other greases or with oils
- Other accessories available by agreement
- Enquiries:  
[industrial-services@schaeffler.com](mailto:industrial-services@schaeffler.com), +49 2407 9149-66.



# Lubrication

## Lever grease gun

The lever grease gun, see table, can be used to manually relubricate radial insert ball bearings via lubrication nipples.

The container on the lever grease gun can be filled with 500 g loose grease or with a 400-g cartridge. The cartridge must conform to DIN 1284 (diameter 53,5 mm, length 235 mm).

The lever grease gun is connected to the lubrication nipple via a reinforced hose. The reinforced hose must be ordered separately, see table.

## Available lever grease guns

Designation	Maximum delivery pressure bar	Delivery quantity per stroke cm <sup>3</sup>
<b>ARCA-GREASE-GUN</b>	800	2

## Available reinforced hoses

Designation	Length mm	Connector
<b>ARCA-GREASE-GUN.HOOK-ON-HOSE</b>	300	Cylindrical lubrication nipple with head 16 mm to DIN 3404
<b>ARCA-GREASE-GUN.HOSE</b>	300	Taper type lubrication nipple to DIN 71412

# Addresses

## Worldwide

You can find all the addresses and contacts for Schaeffler at [www.schaeffler.com](http://www.schaeffler.com)

## Argentina

Schaeffler Argentina S.r.l.  
Av. Alvarez Jonte 1938  
C1416EXR Buenos Aires  
Tel. +(54) 11 / 40 16 15 00  
Fax +(54) 11 / 45 82 33 20  
[info-ar@schaeffler.com](mailto:info-ar@schaeffler.com)

## Armenia

Schaeffler Ukraine GmbH  
Zhylyanskaya Str. 75, 5. Stock,  
Businesscenter «Eurasia»  
01032 Kiev  
Ukraine  
Tel. +(380) 44 520 13 80  
Fax +(380) 44 520 13 81  
[info.ua@schaeffler.com](mailto:info.ua@schaeffler.com)

## Australia

Schaeffler Australia Pty Ltd  
Level 1, Bldg 8, Forest Central  
Business Park  
49 Frenchs Forest Road  
Frenchs Forst, NSW 2086  
Tel. +(61) 2 8977 1000  
Fax +(61) 2 9452 4242  
[sales.au@schaeffler.com](mailto:sales.au@schaeffler.com)

Schaeffler Australia Pty Limited  
Suite 14, Level 3  
74 Doncaster Road  
North Balwyn, VIC 3104  
Tel. +(61) 3 9859 8020  
Fax +(61) 3 9859 8767  
[milos.grujic@schaeffler.com](mailto:milos.grujic@schaeffler.com)

Schaeffler Australia Pty Ltd  
Unit 3, 47 Steel Place  
Morningside, QLD 4170  
Tel. +(61) 7 3399 9161  
Fax +(61) 7 3399 9351  
[martin.grosvenor@schaeffler.com](mailto:martin.grosvenor@schaeffler.com)

## Austria

Schaeffler Austria GmbH  
Ferdinand-Pözl-Straße 2  
2560 Berndorf-St. Veit  
Tel. +(43) 2672 202-0  
Fax +(43) 2672 202-1003  
[info.at@schaeffler.com](mailto:info.at@schaeffler.com)

## Belarus

Schaeffler Technologies AG & Co. KG  
Repräsentanz Weißrussland  
Odoewskogo 117, office 317  
220015 Minsk  
Tel. +(375) 17 336 94 81  
Fax +(375) 17 336 94 82  
[info.by@schaeffler.com](mailto:info.by@schaeffler.com)

## Belgium

Schaeffler Belgium S.P.R.L./B.V.B.A.  
Avenue du Commerce, 38  
1420 Braine L'Alleud  
Tel. +(32) 2 3 89 13 89  
Fax +(32) 2 3 89 13 99  
[info.be@schaeffler.com](mailto:info.be@schaeffler.com)

## Bolivia

Schaeffler Chile Ltda.  
Jose Tomas Rider 1051  
Providencia  
7501037 Santiago  
Chile  
Tel. +(56) 2 477 5000  
Fax +(56) 2 2223 9941  
[info-cl@schaeffler.com](mailto:info-cl@schaeffler.com)

## Bosnia-Herzegovina

Schaeffler Hrvatska d.o.o.  
Ogrizovićeva 28b  
10000 Zagreb  
Croatia  
Tel. +(385) 1 37 01 943  
Fax +(385) 1 37 64 473  
[info.hr@schaeffler.com](mailto:info.hr@schaeffler.com)

## Brazil

Schaeffler Brasil Ltda.  
Av. Independência, 3500-A  
Bairro Eden  
18087-101 Sorocaba, SP  
Tel. +(55) 15 3335 1422  
Tel. 0800 11 10 29  
Fax +(55) 1533 35 19 60  
[sac.br@schaeffler.com](mailto:sac.br@schaeffler.com)

## Bulgaria

Schaeffler Bulgaria OOD  
Dondukov-Blvd. No 62  
Eing. A, 6. Etage, App. 10  
1504 Sofia  
Tel. +(359) 2 946 3900  
+(359) 2 943 4008  
Fax +(359) 2 943 4134  
[info.bg@schaeffler.com](mailto:info.bg@schaeffler.com)

## Canada

Schaeffler Canada Inc.  
100 Alexis Nihon Suite 390  
Montréal, QC H4M 2N8  
Tel. +(1) 514-748-5111  
Tel. 800-361-5841 Toll Free  
Fax +(1) 514-748-6111  
[info.ca@schaeffler.com](mailto:info.ca@schaeffler.com)

Schaeffler Canada Inc.  
2871 Plymouth Drive  
Oakville, ON L6H 5S5  
Tel. +(1) 905-829-2750  
Tel. 800-263-4397 Toll Free  
Fax +(1) 905-829-2563  
[info.ca@schaeffler.com](mailto:info.ca@schaeffler.com)

Schaeffler Canada Inc.  
#106, 7611 Sparrow Drive  
Leduc, AB T9E 0H3  
Tel. +(1) 780-980-3016  
Tel. 800-663-9006 Toll Free  
Fax +(1) 780-980-3037  
[info.ca@schaeffler.com](mailto:info.ca@schaeffler.com)

## Chile

Schaeffler Chile Ltda.  
Jose Tomas Rider 1051  
Providencia  
7501037 Santiago  
Chile  
Tel. +(56) 2 477 5000  
Fax +(56) 2 2223 9941  
[info-cl@schaeffler.com](mailto:info-cl@schaeffler.com)

## China

Schaeffler Holding (China) Co., Ltd.  
No. 1 Antuo Road  
(west side of Anhong Road)  
AnTing, JiaDing District  
201804 Shanghai  
Tel. +(86) 21 3957 6666  
Fax +(86) 21 3957 6600  
[info\\_china@schaeffler.com](mailto:info_china@schaeffler.com)

## Colombia

Schaeffler Colômbia Ltda.  
Cra. 10 N° 97A 13 Torre A  
Ofic 209 Bogotá Trade Center  
Bogotá  
Tel. +(57) 1 621 53 00  
Fax +(57) 1 621 03 22  
[info-co@schaeffler.com](mailto:info-co@schaeffler.com)



# Addresses

## Croatia

Schaeffler Hrvatska d.o.o.  
Ogrizovićeva 28b  
10000 Zagreb  
Tel. +(385) 1 37 01 943  
Fax +(385) 1 37 64 473  
info.hr@schaeffler.com

## Czech Republic

Schaeffler CZ s.r.o.  
Průběžná 74a  
100 00 Praha 10  
Tel. +(420) 267 298 111  
Fax +(420) 267 298 110  
info.cz@schaeffler.com

## Denmark

Schaeffler Danmark ApS  
Jens Baggesens Vej 90P  
8200 Aarhus N  
Tel. +(45) 70 15 44 44  
Fax +(45) 70 15 22 02  
info.dk@schaeffler.com

## Egypt

Delegation Office  
Schaeffler Technologies  
25, El Obour Buildings – Floor 18 – Flat 4  
Salah Salem St.  
11371 Cairo  
Tel. +(20) 2 24012432  
Fax +(20) 2 22612637  
schaeffleregypt@schaeffleregypt.com

## Estonia

Schaeffler Technologies  
Repräsentanz Baltikum  
Duntes iela 23a  
1005 Riga  
Latvia  
Tel. +(371) 67 06 37 95  
Fax +(371) 67 06 37 96  
info.lv@schaeffler.com

## Finland

Schaeffler Finland Oy  
Lautamiehentie 3  
02770 Espoo  
Tel. +(358) 207 36 6204  
Fax +(358) 207 36 6205  
info.fi@schaeffler.com

## France

Schaeffler France SAS  
93, route de Bitche, BP 30186  
67506 Haguenau  
Tel. +(33) 3 88 63 40 40  
Fax +(33) 3 88 63 40 41  
info.fr@schaeffler.com

## Germany

Schaeffler Technologies AG & Co. KG  
Industriestraße 1 – 3  
91074 Herzogenaurach  
Tel. +(49) 9132 82-0  
Fax +(49) 9132 82-4950  
info.de@schaeffler.com

Schaeffler Technologies AG & Co. KG  
Georg-Schäfer-Str. 30  
97421 Schweinfurt  
Tel. +(49) (9721) 91-0  
Fax +(49) (9721) 91-3435  
faginfo@schaeffler.com

FAG Aerospace GmbH & Co. KG  
Georg-Schäfer-Str. 30  
97421 Schweinfurt  
Tel. +49 (0 97 21) 91-33 72  
astrid.hofmann@schaeffler.com

## Hungary

Schaeffler Magyarország Ipari Kft.  
Rétköz u.5  
1118 Budapest  
Tel. +(36) 1 4 81 30 50  
Fax +(36) 1 4 81 30 53  
budapest@schaeffler.com

## India

Schaeffler India Limited  
Maneja  
Vadodara 390 013  
Tel. +(91) 26 52 6426-51  
Fax +(91) 26 52 6388-04/-10  
info.fag.in@schaeffler.com

## Italy

Schaeffler Italia S.r.l.  
Via Dr. Georg Schaeffler, 7  
28015 Momo (Novara)  
Tel. +(39) 3 21 92 92 11  
Fax +(39) 3 21 92 93 00  
info.it@schaeffler.com

## Japan

Schaeffler Japan Co., Ltd.  
Schaeffler R&D Center Building,  
Yokohama Business Park,  
134 Godo-cho, Hodogaya-ku,  
240-0005 Yokohama  
Tel. +(81) 45 287 9001  
Fax +(81) 45 287 9011  
info-japan@schaeffler.com

## Korea

Schaeffler Korea Corporation –  
Guro Office  
A-501, 1258, Guro-dong, Guro-gu,  
Seoul, 152-721  
Tel. +(82) 2 2625-8572  
Fax +(82) 2 2611-6075

## Latvia

Schaeffler Technologies  
Repräsentanz Baltikum  
Duntes iela 23a  
1005 Riga  
Tel. +(371) 7 06 37 95  
Fax +(371) 7 06 37 96  
info.lv@schaeffler.com

## Lithuania

Schaeffler Technologies  
Repräsentanz Baltikum  
Duntes iela 23a  
1005 Riga  
Latvia  
Tel. +(371) 7 06 37 95  
Fax +(371) 7 06 37 96  
info.lv@schaeffler.com

## Luxembourg

Schaeffler Belgium S.P.R.L./B.V.B.A.  
Avenue du Commerce, 38  
1420 Braine L'Alleud  
Belgium  
Tel. +(32) 2 3 89 13 89  
Fax +(32) 2 3 89 13 99  
info.be@schaeffler.com

## Malaysia

Schaeffler Bearings (Malaysia) Sdn. Bhd.  
5-2 Wisma Fiamma, No. 20 Jalan 7A/62A  
Bandar Menjalara  
52200 Kuala Lumpur  
Tel. +(60) 3-6275 0620  
Fax +(60) 3 6275 6421  
marketing\_my@schaeffler.com

Schaeffler Bearings (Malaysia) Sdn. Bhd.  
(Penang Branch)  
No. B-02-28, 2nd Floor, Krystal Point  
303, Jalan Sultan Azlan Shah  
11900 Sungai Nibong  
Tel. +(60) 4 642 3708/3781  
Fax +(60) 4 642 3724

## Mexico

INA México, S.A. de C.V. -  
Rodamientos FAG, S.A. de C.V.  
Henry Ford #141  
Col. Bondojito  
Deleg. Gustavo A. Madero  
07850 Mexico D.F.  
Tel. +(52) 55 5062 6085  
Fax +(52) 55 5739 5850  
distr.indl.mx@schaeffler.com

## Netherlands

Schaeffler Nederland B.V.  
Gildeweg 31  
3771 NB Barneveld  
Tel. +(31) 342 40 30 00  
Fax +(31) 342 40 32 80  
info.nl@schaeffler.com

## New Zealand

Schaeffler New Zealand  
(Unit R, Cain Commercial Centre)  
20 Cain Road  
1135 Penrose  
Tel. +(64) 9 583 1280  
Fax +(64) 9 583 1288  
sales.nz@schaeffler.com

## Norway

Schaeffler Norge AS  
Grenseveien 107B  
0663 Oslo  
Tel. +(47) 23 24 93 30  
Fax +(47) 23 24 93 31  
info.no@schaeffler.com

## Philippines

Schaeffler Philippines Inc  
5th Floor, Optima Building  
221 Saicedo Street, Legaspi Village  
1229 Makati City  
Tel. +(63) 2 759 3583  
Fax +(63) 2 779 8703  
marketing\_ph@schaeffler.com

## Poland

Schaeffler Polska Sp. z o.o.  
Budynek E  
ul. Szyszkowa 35/37  
02-285 Warszawa  
Tel. +(48) 22 8 78 41 20  
Fax +(48) 22 8 78 41 22  
info.pl@schaeffler.com

## Portugal

INA Rolamentos Lda.  
Arrábida Lake Towers  
Rua Daciano Baptista Marques Torre C,  
181, 2º piso  
4400-617 Vila Nova de Gaia  
Tel. +(351) 22 5 32 08 00  
Fax +(351) 22 5 32 08 60  
info.pt@schaeffler.com

Schaeffler Portugal S.A.  
Rua Estrada do Lavradio 25  
2500-294 Caldas da Rainha  
Tel. +(351) 262 837000  
Fax +(351) 262 837011

## Romania

S.C. Schaeffler Romania S.R.L.  
Aleea Schaeffler Nr. 3  
507055 Cristian/Brasov  
Tel. +(40) 268 504816  
Fax +(40) 268 505848  
info.ro@schaeffler.com

## Russia

Schaeffler Russland GmbH  
Leningradsky Prospekt 47, Bau 3  
Business-Center Avion  
125167 Moscow  
Tel. +(7) 495 7 37 76 60  
Fax +(7) 495 7 37 76 61  
info.ru@schaeffler.com

## Saudi Arabia

Schaeffler Middle East FZE  
Road SE101, Schaeffler Building  
Jebel Ali Free Zone – Southside  
Postbox 261808  
Dubai UAE  
United Arab Emirates  
Tel. +(971) 4 81 44 500  
Fax +(971) 4 81 44 601  
info.ae@schaeffler.com

## Serbia

Schaeffler Technologies  
Repräsentanz Serbien  
Branka Krsmanovica 12  
11118 Beograd  
Tel. +(381) 11 308 87 82  
Fax +(381) 11 308 87 75  
fagbgdyu@orion.rs

## Singapore

Schaeffler (Singapore) Pte. Ltd.  
151 Lorong Chuan, #06-01  
New Tech Park, Lobby A  
556741 Singapore  
Tel. +(65) 6540 8600  
Fax +(65) 6540 8668  
info.sg@schaeffler.com

## Slovak Republic

Schaeffler Slovensko, spol. s r.o.  
Ulica Dr. G. Schaefflera 1  
02401 Kysucké Nové Mesto  
Tel. +(421) 41 4 20 51 11  
Fax +(421) 41 4 20 59 18  
info.sk@schaeffler.com

Schaeffler Slovensko, spol. s r.o.  
Nevádzova 5  
821 01 Bratislava  
Tel. +(421) 2 43 294 260  
Fax +(421) 2 48 287 820  
info.sk@schaeffler.com

## Slovenia

Schaeffler Slovenija d.o.o.  
Glavni trg 17/b  
2000 Maribor  
Tel. +(386) 2 22 82 070  
Fax +(386) 2 22 82 075  
info@schaeffler.si

## South Africa

Schaeffler South Africa (Pty.) Ltd.  
1 End Street Ext. Corner Heidelberg Road  
2000 Johannesburg  
Tel. +(27) 11 225 3000  
Fax +(27) 11 334 1755  
info.co.za@schaeffler.com

## Spain

Schaeffler Iberia, S.L.U. –  
División Industria  
C/ Foment, 2  
Polígono Ind. Pont Reixat  
08960 Sant Just Desvern – Barcelona  
Tel. +(34) 93 4 80 34 10  
Fax +(34) 93 3 72 92 50  
info.es@schaeffler.com

## Sweden

Schaeffler Sverige AB  
Charles gata 10  
195 61 Arlandastad  
Tel. +(46) 8 59 51 09 00  
Fax +(46) 8 59 51 09 60  
info.se@schaeffler.com

## Switzerland

Schaeffler Schweiz GmbH  
Badstrasse 14  
8590 Romanshorn  
Tel. +(41) 71 4 66 66 66  
Fax +(41) 71 4 66 63 33  
info.ch@schaeffler.com

## Taiwan

Schaeffler Taiwan Co. Ltd.  
23F, No.76, Sec. 2, Dunhua S. Rd.,  
Da'an Dist.  
Taipei 106  
Tel. +886 2 7730 1911  
Fax +886 2 2707 9964  
info.tw@schaeffler.com

## Thailand

Schaeffler (Thailand) Co., Ltd.  
388 Exchange Tower 31st, 34th Floor,  
Unit 3103, 3403-3404 Sukhumvit Rd.,  
Klongtoey  
Bangkok, 10110  
Tel. +(66) 2697 0000  
Fax +(66) 2697 0001  
info.th@schaeffler.com



# Addresses

## Turkey

Schaeffler Turkey Endüstri ve Otomotiv Ticaret Limited Şirketi  
Ömer Faik Atakan cad. Saray Mah. Yılmaz Plaza No:3  
34768 İstanbul  
Tel. +(90) 212 2 79 27 41  
Fax +(90) 212 2 81 66 45  
info.tr@schaeffler.com

## Ukraine

Schaeffler Ukraine GmbH  
Zhylyanskaya Str. 75, 5. Stock,  
Businesscenter «Eurasia»  
01032 Kiev  
Ukraine  
Tel. +(380) 44 520 13 80  
Fax +(380) 44 520 13 81  
info.ua@schaeffler.com

## United Kingdom

Schaeffler (UK) Ltd  
Forge Lane, Minworth  
Sutton Coldfield B76 1AP  
Tel. +(44) 121 3 13 58 70  
Fax +(44) 121 3 13 00 80  
info.uk@schaeffler.com

The Barden Corporation (UK) Limited  
Plymbridge Road, Estover  
Plymouth, PL6 7LH  
Tel. +(44) 1752 73 55 55  
Fax +(44) 1752 73 34 81  
bardenbearings@schaeffler.com

## United Arab Emirates

Schaeffler Middle East FZE  
Road SE101, Schaeffler Building  
Jebel Ali Free Zone - Southside  
Postbox 261808  
Dubai UAE  
Tel. +971 4 81 44 500  
Fax +971 4 81 44 601  
info.ae@schaeffler.com

## USA

Schaeffler Group USA Inc.  
200 Park Avenue  
P.O. Box 1933  
Danbury, CT 06813-1933  
Tel. +(1) 203 790 5474  
Fax +(1) 203 830 8171  
Walter.Newton@schaeffler.com

The Barden Corporation  
200 Park Avenue  
P.O. Box 2449  
Danbury, CT 06813-2449  
Tel. +(1) 203 744 2211  
Fax +(1) 203 744 3756  
sales@bardenbearings.com

Schaeffler Group USA Inc.  
308 Springhill Farm Road  
Corporate Offices  
Fort Mill, SC 29715  
Tel. +(1) 803 548 8500  
Fax +(1) 803 548 8599  
info.us@schaeffler.com

Schaeffler Group USA Inc.  
5370 Wegman Drive  
Valley City, OH 44280-9700  
Tel. +(1) 800 274 5001  
Fax +(1) 330 273 3522  
luk-ina-fag-as.us@schaeffler.com

## Venezuela

Schaeffler Venezuela C.A.  
Urbanización San José de Tarbes  
Torre BOD, Piso 14, Oficina 14-1  
Valencia  
Tel. +(58) 58 241 825 9250  
Fax +(58) 58 241 825 9705  
ana.acevedo@schaeffler.com

## Vietnam

Schaeffler Vietnam Co., Ltd –  
Ho Chi Minh Sales Office  
6th Floor, TMS Building,  
172 Hai Ba Trung street, Da Kao Ward,  
District 1.  
Ho Chi Minh City  
Tel. +(84) 8 22 20 2777  
Fax +(84) 8 22 20 2776  
marketing\_vn@schaeffler.com

Schaeffler Vietnam Co., Ltd –  
Hanoi Sales Office  
MIPEC Tower, 12th Floor No. 229  
Tay Son Street, Dong Da District  
Ha Noi  
Tel. +(84) 4 3556 0930  
Fax +(84) 4 3556 0931  
marketing\_vn@schaeffler.com







**Schaeffler Technologies  
AG & Co. KG**

Industriestraße 1 – 3  
91074 Herzogenaurach  
Germany  
Internet [www.ina.com](http://www.ina.com)  
E-mail [info.de@schaeffler.com](mailto:info.de@schaeffler.com)

In Germany:

Phone 0180 5003872

Fax 0180 5003873

From other countries:

Phone +49 9132 82-0

Fax +49 9132 82-4950



**Schaeffler Technologies  
AG & Co. KG**

Georg-Schäfer-Straße 30  
97421 Schweinfurt  
Germany  
Internet [www.fag.com](http://www.fag.com)  
E-mail [faginfo@schaeffler.com](mailto:faginfo@schaeffler.com)

In Germany:

Phone 0180 5003872

Fax 0180 5003873

From other countries:

Phone +49 9721 91-0

Fax +49 9721 91-3435

