

TIMKEN

UC-SERIES TIMKEN® BALL BEARING HOUSED UNITS

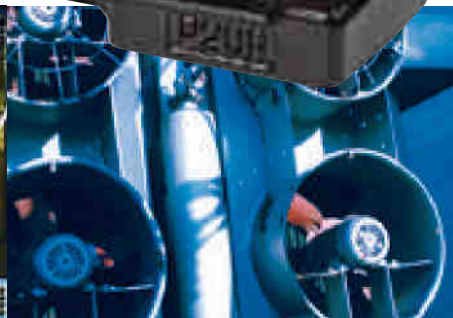
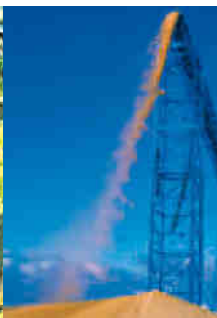

Stronger. **By Design.**

UC-SERIES TIMKEN® BALL BEARING HOUSED UNITS

Introduction	3
Housing Styles	4
Nomenclature.....	5
Features	6
Installation.....	8

HOUSED UNIT TABLES

UCP Pillow Block Units	10
UCF Four-Bolt Flanged Units	12
UCFL Two-Bolt Flanged Units.....	14
UCFC Piloted Round Flanged Units	16
UCT Take-Up Units	18
UC Wide Inner Ring Ball Bearings	20



TIMKEN® BALL BEARING HOUSED UNITS

DESIGNED FOR OPTIMIZED PERFORMANCE

For more than 110 years, Timken innovations continue to keep the world in motion, including the invention of the wide inner ring bearing and the ball bearing housed unit. We continue that innovation by applying our extensive engineering knowledge of bearings, metallurgy, seals and end-user applications to deliver optimized performance from our housed unit product line.



Timken ball bearing housed units help improve efficiencies through:

INCREASED EQUIPMENT UPTIME AND REDUCED MAINTENANCE COST

- Bearings with spherical outer rings and precision-machined cast-iron housings help prevent outer ring rotation.
- Bearings withstand static misalignment of the shaft of ± 3 degrees.
- Designed for normal operation between -20°C and 100°C .
- Wide inner ring ball bearings deliver greater shaft support.
- High-strength housings are suited for most industrial applications.
- Bearings are prelubricated and ready for immediate installation.
- Timken knowledge and support come standard.

ROBUST SEALING DESIGNED FOR THE MOST DEMANDING ENVIRONMENTS

- Precision sealing provides extended bearing life and reduced lubrication leakage.
- Bonded seal design includes a steel flinger for additional bearing protection.
- Effective grease retention and reduced debris and moisture ingress improve bearing performance.

WIDE RANGE OF READY-TO-MOUNT UNITS

- Five different housing designs plus replacement inserts are offered in metric and imperial sizes.
- Set screw locking design allows for easy installation.
- Extensive range of sizes meets the needs of a wide range of applications.
- Interchangeable without modification in many applications.
- Local in-stock availability ensures the service levels you expect.

Timken supports your job sites with a team of service engineers available around the world. Their services help extend maintenance cycles and maximize uptime.

Timken is your single-source for friction management, with a full range of bearings and related accessories including greases, seals, tools, training, repair services and condition monitoring systems.

HOUSING STYLES

Timken offers you the full range of standard series ball bearing housed units with a popular set screw locking mechanism in metric and imperial sizes:

UCP PILLOW BLOCK UNITS

12 mm to 90 mm (1/2 in. to 3 1/2 in.)



UCF FOUR-BOLT FLANGED UNITS

12 mm to 90 mm (1/2 in. to 3 1/2 in.)



UCFL TWO-BOLT FLANGED UNITS

12 mm to 90 mm (1/2 in. to 3 1/2 in.)



UCFC PILOTED ROUND FLANGED UNITS

12 mm to 90 mm (1/2 in. to 3 1/2 in.)



UCT TAKE-UP UNITS

12 mm to 85 mm (1/2 in. to 3 1/4 in.)



UC WIDE INNER RING BALL BEARINGS

12 mm to 90 mm (1/2 in. to 3 1/2 in.)



NOMENCLATURE

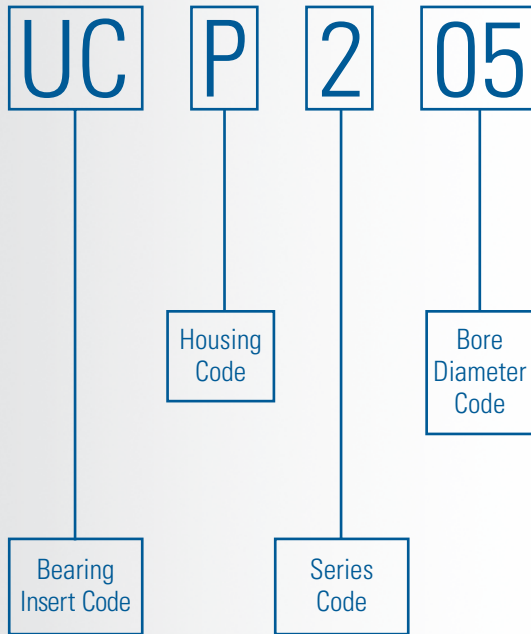

BEARING INSERT CODE	HOUSING CODE	SERIES CODE
<p>UC Cylindrical bore, spherical outer diameter, set screw locking mechanism</p>	<p>P Pillow block unit</p> <p>F Four-bolt flanged unit</p> <p>FL Two-bolt flanged unit</p> <p>T Take-up unit</p> <p>FC Piloted round flanged unit</p>	<p>2 Standard industrial series</p>

CONFIGURATIONS TO MEET YOUR NEEDS

BALL HOUSED UNITS

Standard series – wide inner ring, set screw locking mechanism

HOUSING TYPES

Pillow block, two-bolt flange, four-bolt flange, piloted round flange and take-up

METRIC BORE SIZES 12 mm – 90 mm

INCH BORE SIZES ½ in. – 3½ in.

BORE DIAMETER CODE METRIC

01	Nominal bore diameter = 12 mm
02	Nominal bore diameter = 15 mm
03	Nominal bore diameter = 17 mm
04 or higher	Bore diameter (mm) = bore diameter code x 5

Example:

UCF201 = 12 mm bore (Four-bolt flanged unit)

UCP211 = 55 mm bore (Pillow block unit)

BORE DIAMETER CODE IMPERIAL

–8 or higher	Nominal bore diameter = bore diameter code/16
--------------	---

Example:

UCF201-8 = 8/16 in. or 1/2 in. bore (Four-bolt flanged unit)

UCP205-16 = 16/16 in. or 1 in. bore (Pillow block unit)

FEATURES

Precision formed flinger

Provides the first level of protection against contamination.

High-performance seal

Bonded nitrile rubber seal with an engineered interface to the inner ring.

Hardened and ground seal land

Helps protect against abrasive wear, extending seal life.

Outer ring with spherical outside diameter

Engineered fit between bearing and housing to improve bearing life.

Lubrication delivery system

Precision-machined lubrication groove and holes in the outer ring of the bearing.

Engineered balls and cage

Steel cage provides effective ball guidance and high temperature service capability.

Wide inner ring

Improved shaft support over narrow rings, improving bearing life and reducing misalignment.

Set screw angle

120-degree angle minimizes inner ring distortion for smoother-running bearing.

Cast-iron housing

Incorporates ISO 185 Grade 200 (ASTM A48 Class No. 30) cast iron.

Premium grease

Prelubricated with high-quality lithium-based grease, compatible with most industrial greases.



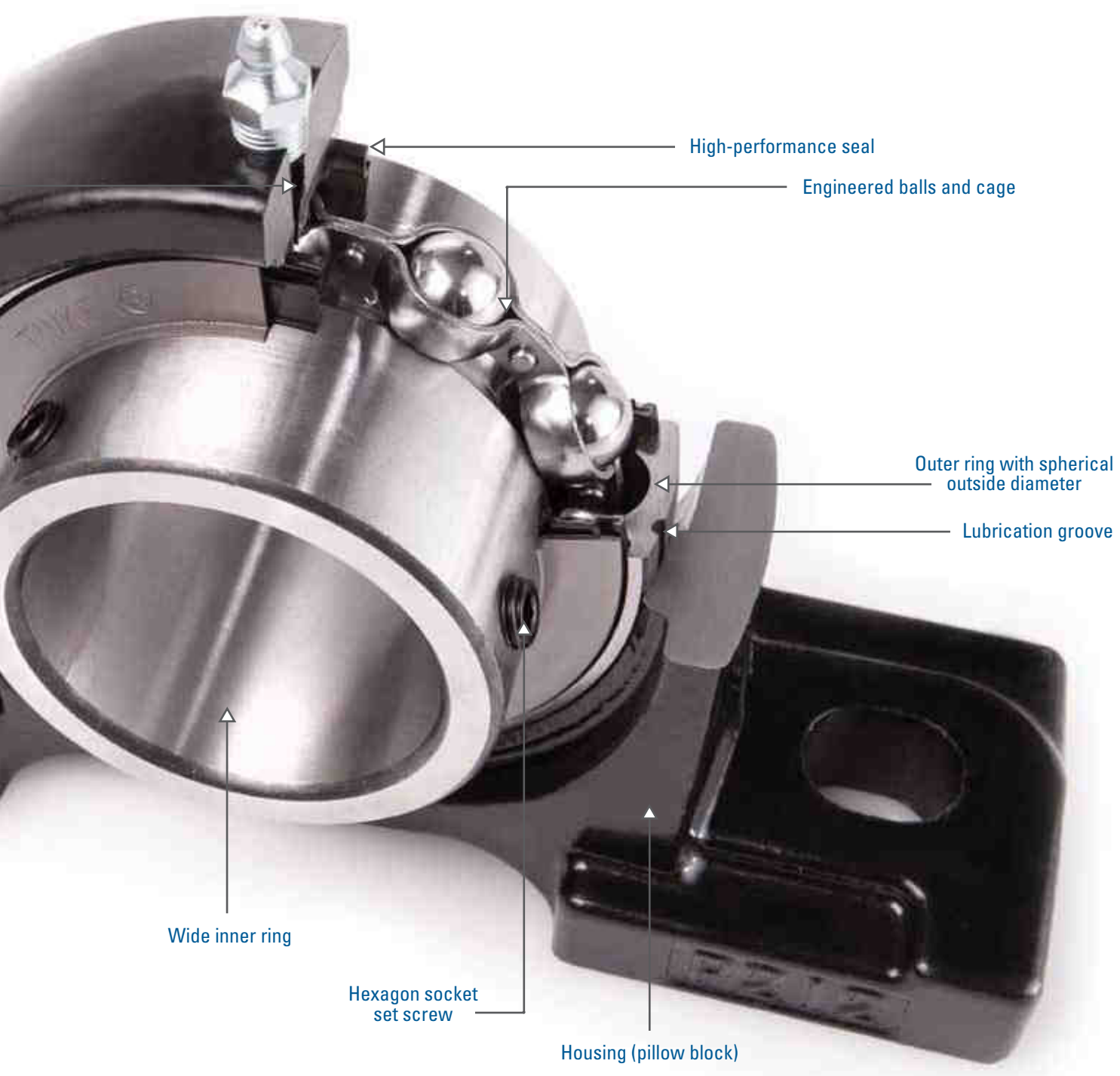

INSTALLATION

Ball bearing housed units are available in a wide variety of sizes and housing styles to accommodate a complete range of operating conditions.

These units generally have cast-iron housings and are designed for mounting on straight shafts with a slip fit. The set screw locking mechanism provides ease in mounting.

1. Ensure that the shaft is clean, free from burrs, straight and of proper diameter. The bearing should not be mounted on a worn section of the shaft. Using shafts with hardness greater than HRC 45 will reduce effectiveness of locking devices. See table 2 on page 9 for suggested shaft tolerances.

Grease fitting in lubrication hole

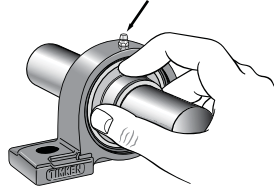

2. Install the supplied grease fitting into the threaded lubrication hole on the housing. Align the bearing in its housing and slide the unit into position on the shaft.

3. Bolt the housing tightly to its mounting supports using an appropriately sized fastener and suggested bolt torque (table 4 on page 9). Flat washers should be used when installing any kind of housed unit. Washers should be properly sized to bolt diameter.

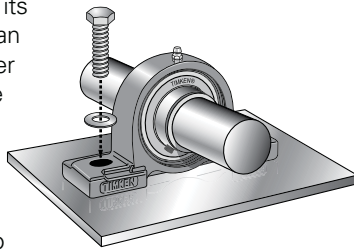

4. Lock the bearing to the shaft by tightening each inner ring set screw incrementally to suggested torque levels (table 3 on page 9).

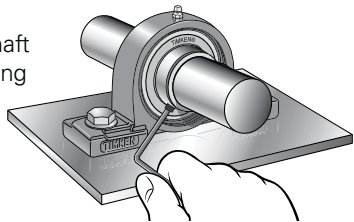

RELUBRICATION

Timken ball bearing housed units are prelubricated. However, periodic relubrication is advisable in some applications for which these units are designed. Consult your equipment manufacturer's operating manual for the specific relubrication cycle. General guidelines are found in table 1.

GENERAL RELUBRICATION SUGGESTIONS FOR GREASED BEARINGS ⁽¹⁾

TABLE 1

CONDITION	RELUBRICATION INTERVAL
Indoor service	Not required
Outdoor service	Two/three times per year
Severe outdoor exposure	Once a month
High contamination/washdown	Once a week

⁽¹⁾As a guideline, relubricate until the first indication of grease is observed purging from the bearing.

WARNING

Failure to observe the following warnings could create a risk of death or serious injury.

Proper maintenance and handling practices are critical. Always follow installation instructions and maintain proper lubrication.

Overheated bearings can ignite explosive atmospheres. Special care must be taken to properly select, install, maintain and lubricate housed unit bearings that are used in or near atmospheres that may contain explosive levels of combustible gases or accumulations of dust such as grain, coal, or other combustible materials. Consult your equipment designer or supplier for installation and maintenance instructions.

Do not use excessive force when mounting or dismounting the unit.

Follow all tolerance, fit and torque recommendations.

Always follow the Original Equipment Manufacturer's installation and maintenance guidelines.

Ensure proper alignment.

Never weld housed units.

Do not heat components with an open flame.

Do not operate at bearing temperatures above 121°C (250°F).

CAUTION

Failure to follow these cautions may result in property damage.

If hammer and bar are used for installation or removal of a part, use a mild steel bar (e.g., 1010 or 1020 grade). Mild steel bars are less likely to cause release of high-speed fragments from the hammer or bar or the part being installed or removed.

Do not use damaged housed units.

FOR ADDITIONAL TIMKEN PRODUCT WARNINGS, VISIT WWW.TIMKEN.COM/WARNINGS.

TECHNICAL DATA

The following tables provide useful installation details related to shaft tolerance and torque for set screws and bolts.

SUGGESTED SHAFT TOLERANCE ⁽¹⁾

TABLE
2

SHAFT SIZE		SHAFT TOLERANCE	
Over	Incl.	Min.	Max.
mm in.	mm in.	mm in.	mm in.
12.000	18.000	0.000	- 0.011
0.500	0.625	0.000	- 0.0005
19.000	30.000	0.000	- 0.013
0.750	1.000	0.000	- 0.0005
31.000	50.000	0.000	- 0.016
1.125	1.938	0.000	- 0.0005
51.000	80.000	0.000	- 0.019
2.000	3.125	0.000	- 0.0010
81.000	90.000	0.000	- 0.022
3.250	3.500	0.000	- 0.0010

SUGGESTED BOLT MOUNTING TORQUE

TABLE
4

BOLT SIZE	TIGHTENING TORQUE
mm	Nm
M10	12 – 21
M12	21 – 37
M14	34 – 60
M16	53 – 93
M20	104 – 186
M22	143 – 256
in.	ft. - lbs.
3/8	9.0 – 15.5
1/2	15.5 – 27.5
5/8	39.0 – 68.5
3/4	76.5 – 137.0
7/8	105.5 – 190.0

⁽¹⁾ These are for normal service; for heavy loads, high speeds or vertical shaft applications, consult your equipment manufacturer or your local Timken representative.

SUGGESTED SET SCREW TIGHTENING TORQUE

TABLE
3

SET SCREW SIZE	TIGHTENING TORQUE
mm	Nm
M6 x 0.75	4
M8 x 1	8.5
M10 x 1.25	17.5
M12 x 1.5	28
in.	in. - lbs.
1/4 – 28 UNF	35.4
5/16 – 24 UNF	75.2

CAST-IRON PILLOW BLOCK UNITS

UCP INDUSTRIAL SERIES

- UCP pillow blocks are suggested for industrial applications where normal loads are encountered.
- Compact, one-piece housing with two-bolt mounting can be installed in any position and makes bearing replacement easy.
- These units use wide inner ring ball bearings with self-aligning spherical outside diameters that compensate for shaft misalignment.
- Bearing prelubricated and ready for immediate installation.
- Grease fitting supplied for relubrication.
- The bonded seal design is well-suited for applications involving wet or dirty environments.
- Bolt-hole spacing and base to center height dimensions are interchangeable with competitive units.

Shaft Dia. d		Pillow block Designation	Bearing Designation	Basic Load Ratings		Dimensions											Bolt Size	Weight
				Dynamic C _r	Static C _{0r}	H	L	L1	A	H1	J	H2	S	B	N	N1		
mm	in.			kN lbs.	kN lbs.	mm in.	mm in.	mm in.	mm in.	mm in.	mm in.	mm in.	mm in.	mm in.	mm in.	mm in.	mm in.	kg lbs.
12		UCP201	UC201	12.8 2878	6.65 1495	30.2 1 3/16	127 5	34.5 1 23/64	38 1 1/2	16 5/8	95 3 3/4	60 2 3/8	12.7 0.500	31 1.220	13 1/2	18 23/32	M10 3/8	0.6 1.3
	1/2	UCP201-8	UC201-8															
15		UCP202	UC202															
	5/8	UCP202-10	UC202-10															
17		UCP203	UC203	12.8 2878	6.65 1495	33.3 1 3/16	127 5	34.5 1 23/64	38 1 1/2	16 5/8	95 3 3/4	64.3 2 17/32	12.7 0.500	31 1.220	13 1/2	18 23/32	M10 3/8	0.7 1.5
	3/4	UCP204-12	UC204-12															
20		UCP204	UC204															
	7/8	UCP205-14	UC205-14	14.0 3147	7.85 1765	36.5 1 7/16	140 5 1/2	37.5 1 31/64	38 1 1/2	16 5/8	105 4 1/8	70 2 49/64	14.3 0.563	34.1 1.343	13 1/2	18 23/32	M10 3/8	0.8 1.8
	15/16	UCP205-15	UC205-15															
25		UCP205	UC205															
	1	UCP205-16	UC205-16	19.5 4384	11.3 2540	42.9 1 11/16	165 6 1/2	47.5 1 55/64	48 1 7/8	17 21/32	121 4 3/4	84 3 5/16	15.9 0.626	38.1 1.500	17 21/32	21 13/16	M14 1/2	1.3 2.9
	1 1/8	UCP206-18	UC206-18															
30		UCP206	UC206															
	1 3/16	UCP206-19	UC206-19	25.7 5778	15.4 3462	47.6 1 7/8	167 6 9/16	46.5 1 53/64	48 1 7/8	18 23/32	127 5	94.6 3 23/32	17.5 0.689	42.9 1.689	17 21/32	21 13/16	M14 1/2	1.6 3.5
	1 1/4	UCP206-20	UC206-20															
	1 1/4	UCP207-20	UC207-20															
	1 5/16	UCP207-21	UC207-21	29.1 6542	17.8 4002	49.2 1 15/16	184 7 1/4	53 2 3/32	54 2 1/8	18 23/32	137 5 13/32	98 3 27/32	19 0.748	49.2 1.937	17 21/32	21 13/16	M14 1/2	2.0 4.4
	1 3/8	UCP207-22	UC207-22															
35		UCP207	UC207															
	1 7/16	UCP207-23	UC207-23	34.1 7666	21.3 4788	54 2 1/8	190 7 15/32	55 2 5/32	54 2 1/8	20 25/32	146 5 3/4	106 4 3/16	19 0.748	49.2 1.937	17 21/32	21 13/16	M14 1/2	2.2 4.9
	1 1/2	UCP208-24	UC208-24															
	1 9/16	UCP208-25	UC208-25															
40		UCP208	UC208	34.1 7666	21.3 4788	54 2 1/8	190 7 15/32	55 2 5/32	54 2 1/8	20 25/32	146 5 3/4	106 4 3/16	19 0.748	49.2 1.937	17 21/32	21 13/16	M14 1/2	2.2 4.9
	1 5/8	UCP209-26	UC209-26															
	1 11/16	UCP209-27	UC209-27															
	1 3/4	UCP209-28	UC209-28															
45		UCP209	UC209															

Continued on next page.

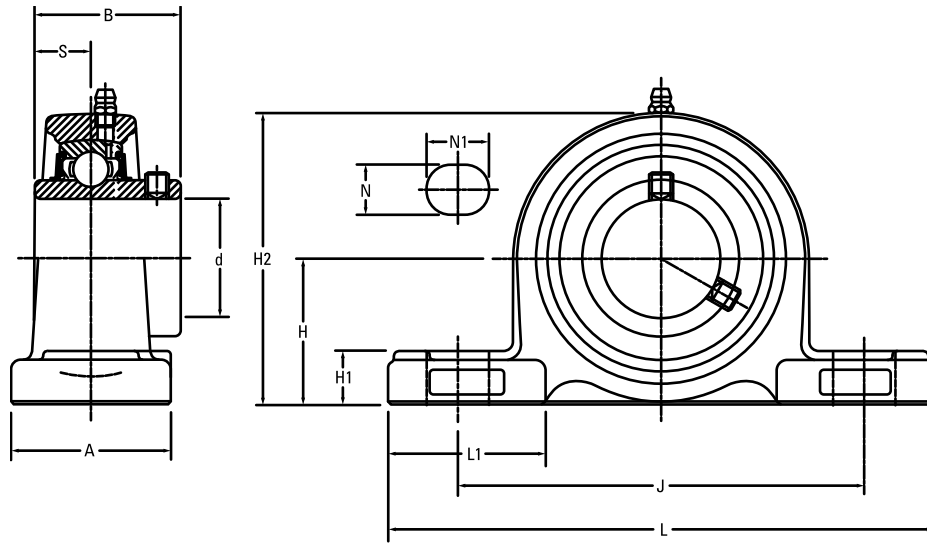

Continued from previous page.

Shaft Dia. d	Pillow block Designation	Bearing Designation	Basic Load Ratings		Dimensions												Bolt Size	Weight	
			Dynamic C _r	Static C _{0r}	H	L	L1	A	H1	J	H2	S	B	N	N1				
mm in.			kN lbs.	kN lbs.	mm in.	mm in.	mm in.	mm in.	mm in.	mm in.	mm in.	mm in.	mm in.	mm in.	mm in.	mm in.	mm in.	mm in.	kg lbs.
50	1 7/8	UCP210-30	35.1 7891	23.3 5238	57.2 2 1/4	206 8 1/8	60 2 3/8	60 2 3/8	21 13/16	159 6 1/4	113 4 7/16	19 0.748	51.6 2.031	20 25/32	22 7/8	M16 5/8	2.9 6.4		
	1 15/16	UCP210-31																UC210-31	
	2	UCP210																UC210	
55	2	UCP210-32	43.4 9757	29.4 6609	63.5 2 1/2	219 8 5/8	64.5 2 35/64	60 2 3/8	23 29/32	171 6 23/32	125 4 29/32	22.2 0.874	55.6 2.189	20 25/32	22 7/8	M16 5/8	3.6 7.9		
	2	UCP211-32																UC211-32	
	2 1/8	UCP211-34																UC211-34	
60	2 3/16	UCP211-35	52.4 11780	36.2 8138	69.8 2 3/4	241 9 1/2	72.5 2 55/64	70 2 3/4	25 31/32	184 7 1/4	138 5 7/16	25.4 1.000	65.1 2.563	20 25/32	25 31/32	M16 5/8	4.9 10.8		
	2 7/16	UCP212-39																UC212-39	
	2 1/2	UCP212-36																UC212-36	
65	2 3/8	UCP212-38	57.2 12859	40.1 9015	76.2 3	265 10 7/16	78 3 1/16	70 2 3/4	27 1 1/16	203 8	150 5 29/32	25.4 1.000	65.1 2.563	35 31/32	30 1 3/16	M20 3/4	5.9 13.0		
	2 7/8	UCP213																UC213	
	3	UCP214-44																UC214-44	
70	2 15/16	UCP214-44	62.2 13983	44.1 9914	79.4 3 1/8	266 10 15/32	75 2 61/64	72 2 27/32	27 1 1/16	210 8 9/32	156 6 5/32	30.2 1.189	74.6 2.937	25 31/32	30 1 3/16	M20 3/4	6.8 15.0		
	3	UCP215-47																UC215-47	
	3 1/8	UCP215																UC215	
75	3	UCP215-48	67.4 15152	48.3 10858	82.6 3 1/4	275 10 13/16	77.5 3 3/64	74 2 29/32	28 1 7/64	217 8 17/32	162 6 3/8	33.3 1.311	77.8 3.063	25 31/32	30 1 3/16	M20 3/4	7.4 16.3		
	3 1/8	UCP216-50																UC216-50	
	3 1/4	UCP217-52																UC217-52	
80	3 1/2	UCP218-56	72.7 16344	53.0 11915	88.9 3 1/2	292 11 1/2	83 3 17/64	78 3 1/16	30 1 3/16	232 9 1/8	174 6 27/32	33.3 1.311	82.6 3.252	25 31/32	35 1 3/8	M20 3/4	9.0 19.8		
	3 3/4	UCP216																UC216	
85	3 1/2	UCP217-52	84.0 18884	61.9 13916	95.2 3 3/4	310 12 7/32	87 3 27/64	83 3 9/32	32 1 1/4	247 9 23/32	185 7 9/32	34.1 1.343	85.7 3.374	25 31/32	40 1 9/16	M20 3/4	10.8 23.8		
	3 3/4	UCP217																UC217	
90	3 1/2	UCP218-56	96.1 21604	71.5 16074	101.6 4	327 12 7/8	94 3 45/64	88 3 15/32	33 1 19/64	262 10 9/16	198 7 25/32	39.7 1.563	96 3.780	27 1 1/16	45 1 25/32	M22 7/8	13.9 30.6		
	3 3/4	UCP218																UC218	

CAST-IRON FOUR-BOLT FLANGED UNITS

UCF INDUSTRIAL SERIES

- UCF four-bolt flanged units are suggested for industrial applications where normal loads are encountered.
- Each unit comes assembled and ready for mounting, using bolts through the flange.
- These units use wide inner ring ball bearings with self-aligning spherical outside diameters that compensate for shaft misalignment.
- Bolt-hole spacing dimensions and shaft center location are interchangeable with competitive units.
- Timken UCF-series set screw flanged units feature the Timken UC bearing insert.
- Bearing prelubricated and ready for immediate installation.
- Grease fitting supplied for relubrication.
- The bonded seal design is well-suited for applications involving wet or dirty environments.
- Housing designed for ease of bearing replacement.

Shaft Dia. d		Four-Bolt Flange Designation	Bearing Designation	Basic Load Ratings		Dimensions									Bolt Size	Weight
				Dynamic C _r	Static C _{0r}	L	J	A1	A	A0	S	B	A2	N		
mm	in.			kN lbs.	kN lbs.	mm in.	mm in.	mm in.	mm in.	mm in.	mm in.	mm in.	mm in.	mm in.	mm in.	kg lbs.
12		UCF201	UC201	12.8 2878	6.65 1495	86 3 3/8	64 2 33/64	11 7/16	25.5 1	33.3 1 5/16	12.7 0.500	31 1.220	15 19/32	12 15/32	M10 3/8	0.6 1.4
	1/2	UCF201-8	UC201-8													
15		UCF202	UC202													
	5/8	UCF202-10	UC202-10													
17		UCF203	UC203	14.0 3147	7.85 1765	95 3 3/4	70 2 3/4	13 1/2	27 1 1/16	35.8 1 13/32	14.3 0.563	34.1 1.343	16 5/8	12 15/32	M10 3/8	0.8 1.8
	3/4	UCF-204-12	UC204-12													
20		UCF-204	UC204													
	7/8	UCF205-14	UC205-14	19.5 4384	11.3 2540	108 4 1/4	83 3 17/64	13 1/2	31 1 7/32	40.2 1 19/32	15.9 0.626	38.1 1.500	18 45/64	12 15/32	M10 3/8	1.2 2.6
	15/16	UCF205-15	UC205-15													
25		UCF205	UC205	25.7 5778	15.4 3462	117 4 19/32	92 3 5/8	15 19/32	34 1 11/32	44.4 1 3/4	17.5 0.689	42.9 1.689	19 3/4	14 35/64	M12 7/16	1.5 3.3
	1	UCF205-16	UC205-16													
	1 1/8	UCF206-18	UC206-18													
30		UCF206	UC206													
	1 3/16	UCF206-19	UC206-19	29.1 6542	17.8 4002	130 5 1/8	102 4 1/64	15 19/32	36 1 13/32	51.2 2 1/32	19 0.748	49.2 1.937	21 53/64	16 5/8	M14 1/2	1.9 4.2
	1 1/4	UCF206-20	UC206-20													
	1 1/4	UCF207-20	UC207-20													
	1 5/16	UCF207-21	UC207-21	34.1 7666	21.3 4788	137 5 13/32	105 4 9/64	16 5/8	38 1 1/2	52.2 2 1/16	19 0.748	49.2 1.937	22 55/64	16 5/8	M14 1/2	2.2 4.9
	1 3/8	UCF207-22	UC207-22													
35		UCF207	UC207	34.1 7666	21.3 4788	137 5 13/32	105 4 9/64	16 5/8	38 1 1/2	52.2 2 1/16	19 0.748	49.2 1.937	22 55/64	16 5/8	M14 1/2	2.2 4.9
	1 7/16	UCF207-23	UC207-23													
	1 1/2	UCF208-24	UC208-24	34.1 7666	21.3 4788	137 5 13/32	105 4 9/64	16 5/8	38 1 1/2	52.2 2 1/16	19 0.748	49.2 1.937	22 55/64	16 5/8	M14 1/2	2.2 4.9
	1 9/16	UCF208-25	UC208-25													
40		UCF208	UC208	34.1 7666	21.3 4788	137 5 13/32	105 4 9/64	16 5/8	38 1 1/2	52.2 2 1/16	19 0.748	49.2 1.937	22 55/64	16 5/8	M14 1/2	2.2 4.9
	1 5/8	UCF209-26	UC209-26													
	1 11/16	UCF209-27	UC209-27													
	1 3/4	UCF209-28	UC209-28													
45		UCF209	UC209													

Continued on next page.

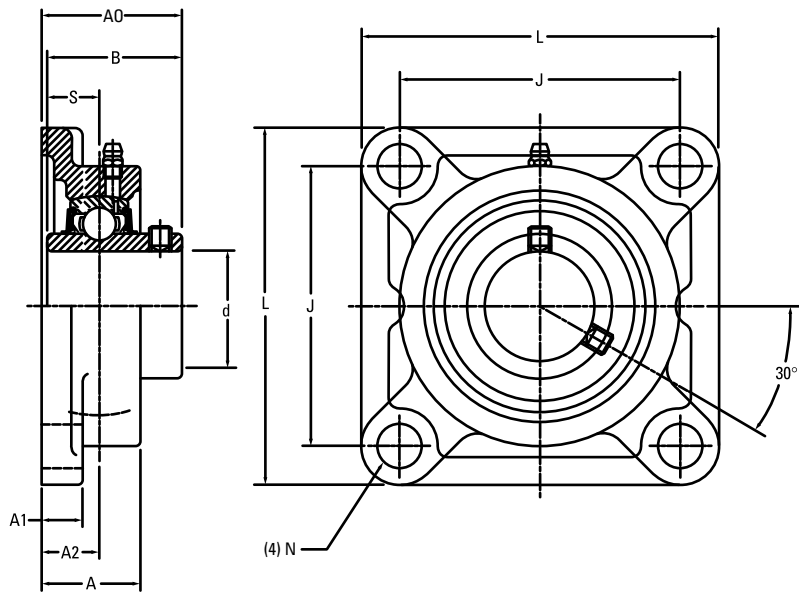

Continued from previous page.

Shaft Dia. d		Four-Bolt Flange Designation	Bearing Designation	Basic Load Ratings		Dimensions									Bolt Size	Weight
				Dynamic C _r	Static C _{0r}	L	J	A1	A	A0	S	B	A2	N		
mm	in.			kN lbs.	kN lbs.	mm in.	mm in.	mm in.	mm in.	mm in.	mm in.	mm in.	mm in.	mm in.	mm in.	kg lbs.
50	1 7/8	UCF210-30	UC210-30	35.1 7891	23.3 5238	143 5 5/8	111 4 3/8	16 5/8	40 1 9/16	54.6 2 5/32	19 0.748	51.6 2.031	22 55/64	16 5/8	M14 1/2	2.5 5.5
	1 15/16	UCF210-31	UC210-31													
	2	UCF210	UC210													
55	2	UCF210-32	UC210-32	43.4 9757	29.4 6609	162 6 3/8	130 5 1/8	18 23/32	43 1 11/16	58.4 2 5/16	22.2 0.874	55.6 2.189	25 63/64	19 3/4	M16 5/8	3.4 7.5
	2	UCF211-32	UC211-32													
	2 1/8	UCF211-34	UC211-34													
60	2 3/16	UCF211-35	UC211-35	52.4 11780	36.2 8138	175 6 7/8	143 5 5/8	18 23/32	48 1 7/8	68.7 2 23/32	25.4 1.000	65.1 2.563	29 1 9/64	19 3/4	M16 5/8	4.2 9.3
	2 1/4	UCF212-36	UC212-36													
	2 3/8	UCF212-38	UC212-38													
65	2 7/16	UCF212-39	UC212-39	57.2 12859	40.1 9015	187 7 3/8	149 5 55/64	22 7/8	50 1 31/32	69.7 2 3/4	25.4 1.000	65.1 2.563	30 1 3/16	19 3/4	M16 5/8	5.2 11.5
	2 1/2	UCF213-40	UC213-40													
	2 3/4	UCF213	UC213													
70	2 3/4	UCF214-44	UC214-44	62.2 13983	44.1 9914	193 7 19/32	152 5 63/64	22 7/8	54 2 1/8	75.4 2 31/32	30.2 1.189	74.6 2.937	31 1 7/32	19 3/4	M16 5/8	5.9 13.0
	2 7/8	UCF214	UC214													
	3	UCF215	UC215													
75	2 15/16	UCF215-47	UC215-47	67.4 15152	48.3 10858	200 7 7/8	159 6 17/64	22 7/8	56 2 7/32	78.5 3 3/32	33.3 1.311	77.8 3.0603	34 1 11/32	19 3/4	M16 5/8	6.4 14.1
	3	UCF215-48	UC215-48													
	3 1/8	UCF216-50	UC216-50													
80	3 1/8	UCF216-50	UC216-50	72.7 16344	53.0 11915	208 8 3/16	165 6 1/2	22 7/8	58 2 9/32	83.3 3 9/32	33.3 1.311	82.6 3.252	34 1 11/32	23 29/32	M20 3/4	7.3 16.1
	3 1/4	UCF216	UC216													
	3 1/2	UCF217-52	UC217-52													
85	3 1/4	UCF217-52	UC217-52	84.0 18884	61.9 13916	220 8 21/32	175 6 57/64	24 15/16	63 2 15/32	87.6 3 7/16	34.1 1.343	85.7 3.374	36 1 13/32	23 29/32	M20 3/4	8.9 19.6
	3 1/2	UCF217	UC217													
	3 3/4	UCF218-56	UC218-56													
90	3 3/4	UCF218-56	UC218-56	96.1 21604	71.5 16074	235 9 1/4	187 7 23/64	25 31/32	68 2 11/16	96.3 3 25/32	39.7 1.563	96 3.780	40 1 9/16	23 29/32	M20 3/4	11.4 25.1
	4	UCF218	UC218													

CAST-IRON TWO-BOLT FLANGED UNITS

UCFL INDUSTRIAL SERIES

- UCFL two-bolt flanged units are suggested for industrial applications where normal loads are encountered.
- This series is primarily designed for applications where the mounting area is restricted.
- Each unit comes assembled and ready for mounting, using bolts through the flange.
- These units use wide inner ring ball bearings with self-aligning spherical outside diameters that compensate for shaft misalignment.
- Bolt-hole spacing dimensions and shaft center location are interchangeable with competitive units.
- Timken UCFL-series set screw flanged units feature the Timken UC bearing insert.
- Bearing prelubricated and ready for immediate installation.
- Grease fitting supplied for relubrication.
- The bonded seal design is well-suited for applications involving wet or dirty environments.
- Housing designed for ease of bearing replacement.

Shaft Dia. d		Two-Bolt Flange Designation	Bearing Designation	Basic Load Ratings		Dimensions										Bolt Size	Weight
				Dynamic C _r	Static C _{0r}	H	J	A1	A	A0	L	A2	S	B	N		
mm	in.			kN lbs.	kN lbs.	mm in.	mm in.	mm in.	mm in.	mm in.	mm in.	mm in.	mm in.	mm in.	mm in.	mm in.	kg lbs.
12		UCFL201	UC201	12.8 2878	6.65 1495	113 4 7/16	90 3 35/64	11 7/16	25.5 1	33.3 1 5/16	60 2 3/8	15 19/32	12.7 0.500	31 1.220	12 15/32	M10 3/8	0.5 1.1
	1/2	UCFL201-8	UC201-8														
15		UCFL202	UC202														
	5/8	UCFL202-10	UC202-10														
17		UCFL203	UC203	14.0 3147	7.85 1765	130 5 1/8	99 3 57/64	13 1/2	27 1 1/16	35.8 1 13/32	68 2 11/16	16 5/8	14.3 0.563	34.1 1.343	16 5/8	M14 1/2	0.6 1.4
	3/4	UCFL204-12	UC204-12														
20		UCFL204	UC204														
	7/8	UCFL205-14	UC205-14														
	15/16	UCFL205-15	UC205-15														
25		UCFL205	UC205	19.5 4384	11.3 2540	148 5 13/16	117 4 39/64	13 1/2	31 1 7/32	40.2 1 19/32	80 3 5/32	18 45/64	15.9 0.626	38.1 1.500	16 5/8	M14 1/2	1.0 2.1
	1	UCFL205-16	UC205-16														
	1 1/8	UCFL206-18	UC206-18														
30		UCFL206	UC206	25.7 5778	15.4 3462	161 6 11/32	130 5 1/8	14 9/16	34 1 11/32	44.4 1 3/4	90 3 17/32	19 3/4	17.5 0.689	42.9 1.689	16 5/8	M14 1/2	1.2 2.6
	1 3/16	UCFL206-19	UC206-19														
	1 1/4	UCFL206-20	UC206-20														
	1 1/4	UCFL207-20	UC207-20														
	1 5/16	UCFL207-21	UC207-21														
	1 3/8	UCFL207-22	UC207-22														
35		UCFL207	UC207	29.1 6542	17.8 4002	175 6 3/8	144 5 43/64	14 9/16	36 1 13/32	51.2 2 1/32	100 3 15/16	21 53/64	19 0.748	49.2 1.937	16 5/8	M14 1/2	1.6 3.5
	1 7/16	UCFL207-23	UC207-23														
	1 1/2	UCFL208-24	UC208-24														
	1 9/16	UCFL208-25	UC208-25														
40		UCFL208	UC208	34.1 7666	21.3 4788	188 7 13/32	148 5 53/64	15 19/32	38 1 1/2	52.2 2 1/16	108 4 1/4	22 55/64	19 0.748	49.2 1.937	19 3/4	M16 5/8	1.9 4.2
	1 5/8	UCFL209-26	UC209-26														
	1 11/16	UCFL209-27	UC209-27														
	1 3/4	UCFL209-28	UC209-28														
45		UCFL209	UC209														

Continued on next page.

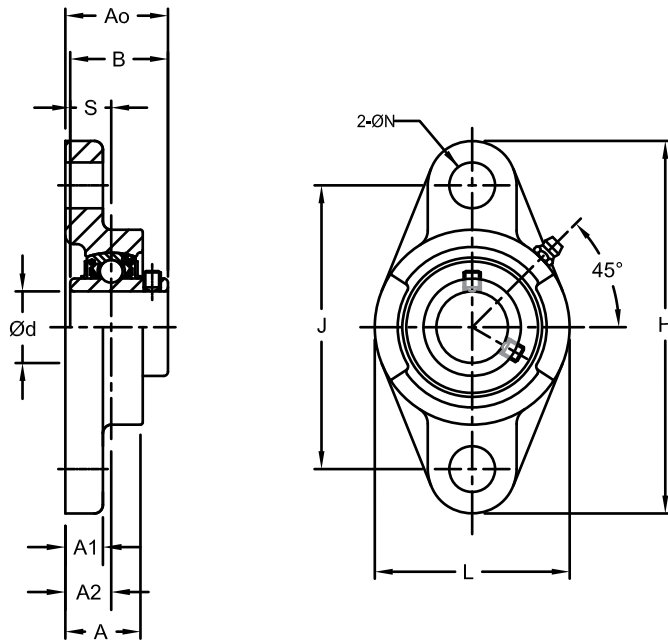

Continued from previous page.

Shaft Dia. d		Two-Bolt Flange Designation	Bearing Designation	Basic Load Ratings		Dimensions										Bolt Size	Weight
				Dynamic C _r	Static C _{0r}	H	J	A1	A	A0	L	A2	S	B	N		
mm	in.			kN lbs.	kN lbs.	mm in.	mm in.	mm in.	mm in.	mm in.	mm in.	mm in.	mm in.	mm in.	mm in.	mm in.	kg lbs.
50	1 7/8	UCFL210-30	UC210-30	35.1 7891	23.3 5238	197 7 3/4	157 6 3/16	15 19/32	40 1 9/16	54.6 2 5/32	115 4 17/32	22 55/64	19 0.748	51.6 2.031	19 3/4	M16 5/8	2.2 4.9
	1 15/16	UCFL210-31	UC210-31														
		UCFL210	UC210														
55	2	UCFL210-32	UC210-32	43.4 9757	29.4 6609	224 8 13/16	184 7 1/4	18 23/32	43 1 11/16	58.4 2 5/16	130 5 1/8	25 63/64	22.2 0.874	55.6 2.189	19 3/4	M16 5/8	3.3 7.3
	2	UCFL211-32	UC211-32														
	2 1/8	UCFL211-34	UC211-34														
60	2 3/16	UCFL211-35	UC211-35	52.4 11780	36.2 8138	250 9 27/32	202 7 61/64	18 23/32	48 1 7/8	68.7 2 23/32	140 5 1/2	29 1 9/64	25.4 1.000	65.1 2.563	23 29/32	M20 3/4	4.2 9.3
	2 1/4	UCFL212-36	UC212-36														
	2 3/8	UCFL212-38	UC212-38														
65	2 7/16	UCFL212-39	UC212-39	57.2 12859	40.1 9015	258 10 5/32	210 8 17/64	20 25/32	50 1 31/32	69.7 2 3/4	155 6 3/32	30 1 3/16	25.4 1.00	65.1 2.563	23 29/32	M20 3/4	5.1 11.2
	2 1/2	UCFL213-40	UC213-40														
		UCFL213	UC213														
70	2 3/4	UCFL214-44	UC214-44	62.2 13983	44.1 9914	265 10 7/16	216 8 1/2	20 25/32	54 2 1/8	75.4 2 31/32	160 6 5/16	31 1 7/32	30.2 1.189	74.6 2.937	23 29/32	M20 3/4	5.7 12.6
		UCFL214	UC214														
	2 15/16	UCFL215-47	UC215-47														
75		UCFL215	UC215	67.4 15152	48.3 10858	275 12 13/16	225 8 55/64	20 25/32	56 2 7/32	78.5 3 3/32	165 6 1/2	34 1 11/32	33.3 1.311	77.8 3.063	23 29/32	M20 3/4	6.4 14.1
	3	UCFL215-48	UC215-48														
	3 1/8	UCFL216-50	UC216-50														
80		UCFL216	UC216	72.7 16344	53 11915	290 11 13/32	233 9 11/64	20 25/32	58 2 9/32	83.3 3 9/32	180 7 3/32	34 1 11/32	33.3 1.311	82.6 3.252	25 63/64	M22 7/8	7.8 17.2
	3 1/4	UCFL217-52	UC217-52														
85		UCFL217	UC217	84 18884	61.9 13916	305 12	248 9 49/64	22 7/8	63 2 15/32	87.6 3 7/16	190 7 15/32	36 1 27/64	34.1 1.343	85.7 3.374	25 63/64	M22 7/8	9.8 21.6
	3 1/2	UCFL218-56	UC218-56														
90		UCFL218	UC218	96.1 21604	71.5 16074	320 12 19/32	265 10 7/16	23 29/32	68 2 11/16	96.3 3 25/32	205 8 1/16	40 1 37/64	39.7 1.563	96 3.78	25 63/64	M22 7/8	12.3 27.1

CAST-IRON PILOTED ROUND FLANGED UNITS

UCFC INDUSTRIAL SERIES

- UCFC piloted round flanged units ensure accurate mounting fits and provide better support for heavy loads.
- Each unit comes assembled and ready for mounting, using bolts through the flange.
- These units use wide inner ring ball bearings with self-aligning spherical outside diameters that compensate for shaft misalignment.
- Bolt-hole spacing dimensions and shaft center location are interchangeable with competitive units.
- Timken UCFC-series set screw flanged units feature the Timken UC bearing insert.
- Bearing prelubricated and ready for immediate installation.
- Grease fitting supplied for relubrication.
- The bonded seal design is well-suited for industrial applications involving wet or dirty environments.
- Housing designed for ease of bearing replacement.

Shaft Dia. d		Round Flange Cartridge Designation	Bearing Designation	Basic Load Ratings		Dimensions											Bolt Size	Weight	
				Dynamic C _r	Static C _{0r}	L	J	J1	A1	A2	A3	A4	H3	S	B	N			
mm	in.			kN lbs.	kN lbs.	mm in.	mm in.	mm in.	mm in.	mm in.	mm in.	mm in.	mm in.	mm in.	mm in.	mm in.	mm in.	kg lbs.	
12		UCFC201	UC201	12.80 2878	6.65 1495	100 3 15/16	78 3 5/64	55.1 2 11/64	20.5 13/16	10 25/64	5 13/64	28.3 1 1/8	62 2.441	12.7 0.500	31 1.220	12 15/32	M10 3/8	0.7 1.5	
	1/2	UCFC201-8	UC201-8																
15		UCFC202	UC202																
	5/8	UCFC202-10	UC202-10																
17		UCFC203	UC203	14.00 3147	7.85 1765	115 4 17/32	90 3 35/64	63.6 2 1/2	21 13/16	10 25/64	6 15/64	29.8 1 3/16	70 2.756	14.3 0.563	34.1 1.343	12 15/32	M10 3/8	1.0 2.2	
	3/4	UCFC204-12	UC204-12																
20		UCFC204	UC204																
	7/8	UCFC205-14	UC205-14																
	15/16	UCFC205-15	UC205-15																
25		UCFC205	UC205	19.50 4384	11.30 2540	125 4 29/32	100 3 15/16	70.7 2 25/32	23 29/32	10 25/64	8 5/16	32.2 1 9/32	80 3.150	15.9 0.626	38.1 1.500	12 15/32	M10 3/8	1.3 2.9	
	1	UCFC205-16	UC205-16																
	1 1/8	UCFC206-18	UC206-18																
30		UCFC206	UC206	25.70 5778	15.40 3462	135 5 5/16	110 4 21/64	77.8 3 1/16	26 1 1/32	11 7/16	8 5/16	36.4 1 7/16	90 3.543	17.5 0.689	42.9 1.689	14 35/64	M12 7/16	1.7 3.7	
	1 3/16	UCFC206-19	UC206-19																
	1 1/4	UCFC206-20	UC206-20																
	1 1/4	UCFC207-20	UC207-20																
	1 5/16	UCFC207-21	UC207-21																
	1 3/8	UCFC207-22	UC207-22																
35		UCFC207	UC207	29.10 6542	17.80 4002	145 5 23/32	120 4 23/32	84.8 3 11/32	26 1 1/32	11 7/16	10 25/64	41.2 1 5/8	100 3.937	19 0.748	49.2 1.937	14 35/64	M12 7/16	2.0 4.4	
	1 7/16	UCFC207-23	UC207-23																
	1 1/2	UCFC208-24	UC208-24																
	1 9/16	UCFC208-25	UC208-25																
40		UCFC208	UC208	34.10 7666	21.30 4788	160 6 5/16	132 5 13/64	93.3 3 43/64	26 1 1/32	10 25/64	12 15/32	40.2 1 19/32	105 4.134	19 0.748	49.2 1.937	16 5/8	M14 1/2	2.6 5.7	
	1 5/8	UCFC209-26	UC209-26																
	1 11/16	UCFC209-27	UC209-27																
	1 3/4	UCFC209-28	UC209-28																
45		UCFC209	UC209																

Continued on next page.

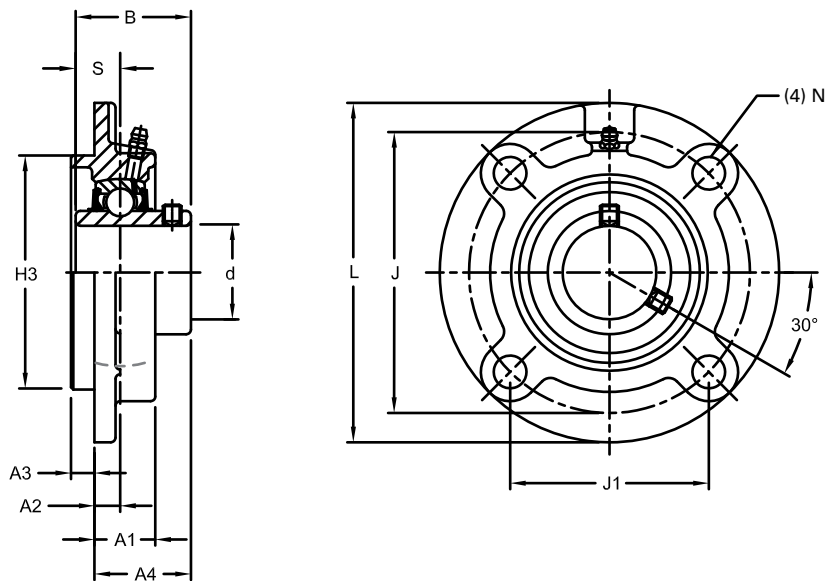

Continued from previous page.

Shaft Dia. d	Round Flange Cartridge Designation	Bearing Designation	Basic Load Ratings		Dimensions												Bolt Size	Weight	
			Dynamic C _r	Static C _{0r}	L	J	J1	A1	A2	A3	A4	H3	S	B	N				
mm	in.		kN lbs.	kN lbs.	mm in.	mm in.	mm in.	mm in.	mm in.	mm in.	mm in.	mm in.	mm in.	mm in.	mm in.	mm in.	mm in.	mm in.	kg lbs.
50	1 7/8	UCFC210-30	35.10 7891	23.30 5238	165 6 1/2	138 5 7/16	97.6 3 27/32	28 1 3/32	10 25/64	12 15/32	42.6 1 11/16	110 4.331	19 0.748	51.6 2.031	16 5/8	M14	2.9 6.4		
	1 15/16	UCFC210-31																UC210-31	
	2	UCFC210																UC210	
55	2	UCFC210-32	43.40 9757	29.40 6609	185 7 9/32	150 5 29/32	106.1 4 11/64	31 1 7/32	13 33/64	12 15/32	46.4 1 13/16	125 4.921	22.2 0.874	55.6 2.189	19 3/4	M16	4.2 9.3		
	2	UCFC211-32																UC211-32	
	2 1/8	UCFC211-34																UC211-34	
60	2 3/16	UCFC211-35	52.40 11780	36.20 8138	195 7 11/16	160 6 19/64	113.1 4 29/64	36 1 13/32	17 43/64	12 15/32	56.7 2 7/32	135 5.315	25.4 1.000	65.1 2.563	19 3/4	M16	5.0 11.0		
	2 1/4	UCFC212-36																UC212-36	
	2 3/8	UCFC212-38																UC212-38	
65	2 7/16	UCFC212-39	57.20 12859	40.10 9015	205 8 1/16	170 6 11/16	120.2 4 47/64	36 1 13/32	16 5/8	14 35/64	55.7 2 3/16	145 5.709	25.4 1.000	65.1 2.563	19 3/4	M16	5.6 12.3		
	2 1/2	UCFC213-40																UC213-40	
	2 3/4	UCFC213																UC213	
70	2 3/4	UCFC214-44	62.20 13983	44.10 9914	215 8 15/32	177 6 31/32	125.1 4 59/64	40 1 9/16	17 43/64	14 35/64	61.4 2 13/32	150 5.906	30.2 1.189	74.6 2.937	19 3/4	M16	6.8 15.0		
	2 15/16	UCFC214																UC214	
	3	UCFC215-47																UC215-47	
75	2 15/16	UCFC215-47	67.40 15152	48.30 10858	220 8 21/32	184 7 1/4	130.1 5 1/8	40 1 9/16	18 45/64	16 5/8	62.5 2 15/32	160 6.299	33.3 1.311	77.8 3.063	19 3/4	M16	7.2 15.9		
	3	UCFC215																UC215	
	3 1/8	UCFC215-48																UC215-48	
80	3 1/8	UCFC216-50	72.70 16344	53.00 11915	240 9 7/16	200 7 7/8	141.4 5 9/16	42 1 29/32	18 45/64	16 5/8	67.3 2 21/32	170 6.693	33.3 1.311	82.6 3.252	23 29/32	M20	8.7 19.2		
	3 1/4	UCFC216																UC216	
	3 1/4	UCFC217-52																UC217-52	
85	3 1/4	UCFC217-52	84.00 18884	61.90 13916	250 9 27/32	208 8 3/16	147.1 5 51/64	45 1 25/32	18 45/64	18 45/64	69.6 2 3/4	180 7.086	34.1 1.343	85.7 3.374	23 29/32	M20	11.7 25.8		
	3 1/2	UCFC217																UC217	
	3 1/2	UCFC218-56																UC218-56	
90	3 1/2	UCFC218-56	96.10 21604	71.50 16074	265 10 7/16	220 8 21/32	155.5 6 1/8	50 1 31/32	22 55/64	18 45/64	78.3 3 3/32	190 7.480	39.7 1.563	96 3.78	23 29/32	M20	14.8 32.6		

CAST-IRON TAKE-UP UNITS

UCT INDUSTRIAL SERIES

- UCT take-up units are used where shaft adjustment and belt-tightening devices are required, such as in conveyor applications.
- These units provide compact, efficient supports for adjustable shafts and conveyor take-up pulleys.
- Each unit comes assembled and ready for mounting.
- These units use wide inner ring ball bearings with self-aligning spherical outside diameters that compensate for shaft misalignment.
- Bolt-hole spacing dimensions and shaft center location are interchangeable with competitive units.
- Timken UCT-series take-up units feature the Timken UC bearing insert.
- Bearing prelubricated and ready for immediate installation.
- Grease fitting supplied for relubrication.
- The bonded seal design is well-suited for industrial applications involving wet or dirty environments.
- Housing designed for ease of bearing replacement.

Shaft Dia. d		Take-Up Unit Designation	Bearing Designation	Basic Load Ratings		Dimensions															Weight
				Dynamic C _r	Static C _{0r}	H	H1	L2	L1	A2	A	N	L	H2	S	B	L3	N1	N2	A1	
mm	in.			kN lbs.	kN lbs.	mm in.	mm in.	mm in.	mm in.	mm in.	mm in.	mm in.	mm in.	mm in.	mm in.	mm in.	mm in.	mm in.	mm in.	mm in.	kg lbs.
12		UCT201	UC201	12.8 2878	6.65 1495	89 3 1/2	76 2 63/64	10 13/32	61 2 13/32	21 13/16	32 1 1/4	19 3/4	94 3 11/16	51 2	12.7 0.500	31 1.220	51 2	16 5/8	32 1 1/4	12 15/32	0.8 1.8
	1/2	UCT201-8	UC201-8																		
15		UCT202	UC202	12.8 2878	6.65 1495	89 3 1/2	76 2 63/64	10 13/32	61 2 13/32	21 13/16	32 1 1/4	19 3/4	94 3 11/16	51 2	12.7 0.500	31 1.220	51 2	16 5/8	32 1 1/4	12 15/32	0.8 1.8
	5/8	UCT202-10	UC202-10																		
17		UCT203	UC203																		
	3/4	UCT204-12	UC204-12	14 3147	7.85 1765	89 3 1/2	76 2 63/64	10 13/32	62 2 7/16	24 15/16	32 1 1/4	19 3/4	97 3 13/16	51 2	14.3 0.563	34.1 1.343	51 2	16 5/8	32 1 1/4	12 15/32	0.8 1.9
20		UCT204	UC204																		
	7/8	UCT205-14	UC205-14	19.5 4384	11.3 2540	102 4 1/2	89 3 1/2	10 13/32	70 2 3/4	28 1 3/32	37 1 15/32	22 7/8	113 4 7/16	56 2 7/32	15.9 0.626	38.1 1.500	57 2 1/4	16 5/8	37 1 15/32	12 15/32	1.3 2.9
	15/16	UCT205-15	UC205-15																		
25		UCT205	UC205																		
	1	UCT205-16	UC205-16	25.7 5778	15.4 3462	102 4 1/2	89 3 1/2	13 1/2	78 3 1/16	30 1 3/16	37 1 15/32	22 7/8	129 5 3/32	64 2 17/32	17.5 0.689	42.9 1.689	64 2 17/32	16 5/8	37 1 15/32	12 15/32	1.6 3.5
	1 1/8	UCT206-18	UC206-18																		
30		UCT206	UC206																		
	1 3/16	UCT206-19	UC206-19	29.1 6542	17.8 4002	114 4 1/2	102 4 1/4	16 5/8	88 3 15/32	33 1 5/16	49 1 15/16	29 1 5/32	144 5 21/32	83 3 9/32	19 0.748	49.2 1.937	83 3 9/32	19 3/4	49 1 15/16	16 5/8	2.5 5.5
	1 1/4	UCT206-20	UC206-20																		
	1 1/4	UCT207-20	UC207-20																		
	1 5/16	UCT207-21	UC207-21	34.1 7666	21.3 4788	117 4 19/32	102 4 1/4	16 5/8	87 3 7/16	35 1 3/8	49 1 15/16	29 1 5/32	144 5 21/32	83 3 9/32	19 0.748	49.2 1.937	83 3 9/32	19 3/4	49 1 15/16	16 5/8	2.5 5.5
	1 3/8	UCT207-22	UC207-22																		
35		UCT207	UC207																		
	1 7/16	UCT207-23	UC207-23	34.1 7666	21.3 4788	117 4 19/32	102 4 1/4	16 5/8	87 3 7/16	35 1 3/8	49 1 15/16	29 1 5/32	144 5 21/32	83 3 9/32	19 0.748	49.2 1.937	83 3 9/32	19 3/4	49 1 15/16	16 5/8	2.5 5.5
	1 1/2	UCT208-24	UC208-24																		
	1 9/16	UCT208-25	UC208-25																		
40		UCT208	UC208	34.1 7666	21.3 4788	117 4 19/32	102 4 1/4	16 5/8	87 3 7/16	35 1 3/8	49 1 15/16	29 1 5/32	144 5 21/32	83 3 9/32	19 0.748	49.2 1.937	83 3 9/32	19 3/4	49 1 15/16	16 5/8	2.5 5.5
	1 5/8	UCT209-26	UC209-26																		
	1 11/16	UCT209-27	UC209-27																		
	1 3/4	UCT209-28	UC209-28	34.1 7666	21.3 4788	117 4 19/32	102 4 1/4	16 5/8	87 3 7/16	35 1 3/8	49 1 15/16	29 1 5/32	144 5 21/32	83 3 9/32	19 0.748	49.2 1.937	83 3 9/32	19 3/4	49 1 15/16	16 5/8	2.5 5.5
45		UCT209	UC209																		

Continued on next page.

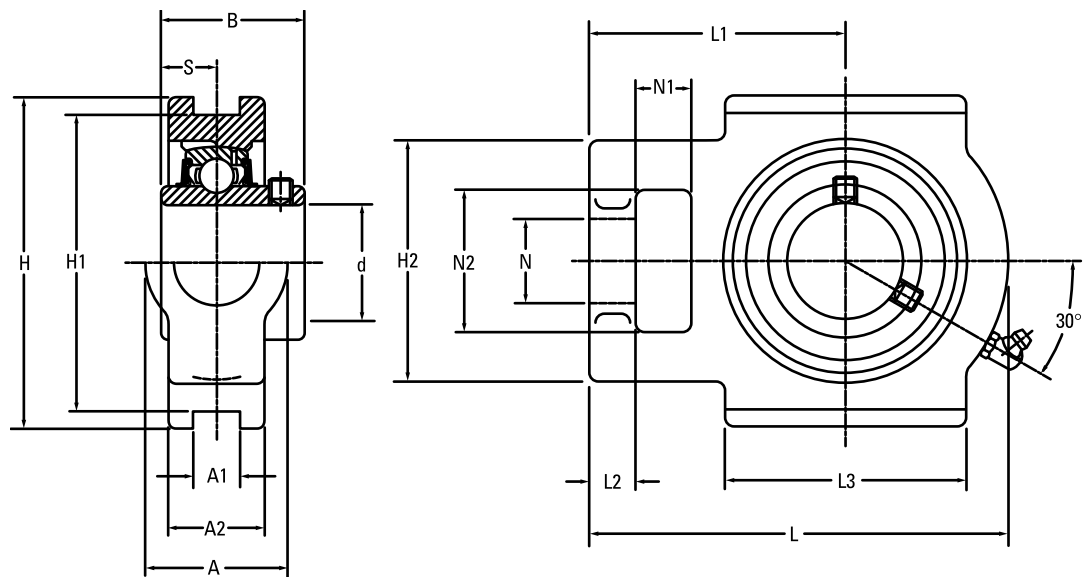

Continued from previous page.

Shaft Dia. d	Take-Up Unit Designation	Bearing Designation	Basic Load Ratings		Dimensions															Weight	
			Dynamic C _r	Static C _{0r}	H	H1	L2	L1	A2	A	N	L	H2	S	B	L3	N1	N2	A1		
mm	in.		kN lbs.	kN lbs.	mm in.	mm in.	mm in.	mm in.	mm in.	mm in.	mm in.	mm in.	mm in.	mm in.	mm in.	mm in.	mm in.	mm in.	mm in.	mm in.	kg lbs.
	1 7/8	UCT210-30	UC210-30																		
	1 15/16	UCT210-31	UC210-31																		
50		UCT210	UC210	35.1 7891	23.3 5238	117 4 19/32	102 4 1/64	16 5/8	90 3 17/32	37 1 15/32	49 1 15/16	29 1 5/32	149 5 7/8	83 3 9/32	19 0.748	51.6 2.031	86 3 3/8	19 3/4	49 1 15/16	16 5/8	2.6 5.7
	2	UCT210-32	UC210-32																		
	2	UCT211-32	UC211-32																		
	2 1/8	UCT211-34	UC211-34	43.4 9757	29.4 6609	146 5 3/4	130 5 1/8	19 3/4	106 4 3/16	38 1 1/2	64 2 17/32	35 1 3/8	171 6 23/32	102 4 1/32	22.2 0.874	55.6 2.189	95 3 3/4	25 31/32	64 2 17/32	22 55/64	4.0 8.8
	2 3/16	UCT211-35	UC211-35																		
	2 1/4	UCT212-36	UC212-36																		
60		UCT212	UC212	52.4 11780	36.2 8138	146 5 3/4	130 5 1/8	19 3/4	119 4 11/16	42 1 21/32	64 2 17/32	35 1 3/8	194 7 5/8	102 4 1/32	25.4 1.000	65.1 2.563	102 4 1/32	32 1 1/4	64 2 17/32	22 55/64	4.9 10.8
	2 3/8	UCT212-38	UC212-38																		
	2 7/16	UCT212-39	UC212-39																		
	2 1/2	UCT213-40	UC213-40	57.2 12859	40.1 9015	167 6 9/16	151 5 15/16	21 13/16	137 5 13/32	44 1 23/32	70 2 3/4	41 1 5/8	224 8 13/16	111 4 3/8	25.4 1.000	65.1 2.563	121 4 3/4	32 1 1/4	70 2 3/4	26 1 1/32	6.9 15.2
	2 3/4	UCT214-44	UC214-44	62.2 13983	44.1 9914	167 6 9/16	151 5 15/16	21 13/16	137 5 13/32	46 1 13/16	70 2 3/4	41 1 5/8	224 8 13/16	111 4 3/8	30.2 1.189	74.6 2.937	121 4 3/4	32 1 1/4	70 2 3/4	26 1 1/32	7.0 15.4
	2 15/16	UCT215-47	UC215-47	67.4 15152	48.3 10858	167 6 9/16	151 5 15/16	21 13/16	140 5 1/2	48 1 7/8	70 2 3/4	41 1 5/8	232 9 1/8	111 4 3/8	33.3 1.331	77.8 3.063	121 4 3/4	32 1 1/4	70 2 3/4	26 1 1/32	7.3 16.1
	3	UCT215-48	UC215-48																		
	3 1/8	UCT216-50	UC216-50	72.7 16344	53 11915	184 7 1/4	165 6 1/2	21 13/16	140 5 1/2	51 2	70 2 3/4	41 1 5/8	235 9 1/4	111 4 3/8	33.3 1.331	82.6 3.252	121 4 3/4	32 1 1/4	70 2 3/4	26 1 1/32	8.2 18.1
80		UCT216	UC216																		
	3 1/4	UCT217-52	UC217-52	84 18884	61.9 13916	198 7 25/32	173 6 13/16	29 1 5/32	162 6 3/8	54 2 1/8	73 2 7/8	48 1 7/8	260 10 1/4	124 4 7/8	34.1 1.343	85.7 3.374	157 6 3/16	38 1 1/2	73 2 7/8	30 1 3/16	11 24.3
85		UCT217	UC217																		

WIDE INNER RING BALL BEARINGS

UC INDUSTRIAL SERIES

- The UC wide inner ring ball bearing uses a popular set screw locking mechanism and is suggested for industrial applications where normal loads are encountered.
- The set screw mounting feature is ideal for reversing load applications.
- Bearing prelubricated and ready for immediate installation.
- The wide inner ring provides effective shaft support for a broad range of industrial applications.
- The positive contact of the land-riding bonded nitrile seal helps protect against harmful contaminants and retains lubricant under severe operating conditions.
- An external steel flinger provides additional protection from contamination.
- The UC-series features superfinished raceways, grade-10 balls for smooth running and low noise operation.
- UC-series wide inner ring ball bearings have spherical outside diameters for use in housings with corresponding spherical inside surfaces to compensate for shaft misalignment.

Shaft Dia. d	Bearing Designation	Basic Load Ratings		Dimensions							Min. Fillet Radius r (min.)	Set Screw Size G	Weight
		Dynamic C _r	Static C _{0r}	D	C	B	S2	C1	S	S1			
mm in.		kN lbs.	kN lbs.	mm in.	mm in.	mm in.	mm in.	mm in.	mm in.	mm in.	mm in.	mm in.	kg lbs.
12	UC201												
1/2	UC201-8											M6×0.75 1/4-28UNF	0.2
15	UC202	12.8 2878	6.65 1495	47 1.850	16 0.630	31 1.220	5 0.197	3.9 0.153	12.7 0.500	18.3 0.720	0.6 0.024	M6×0.75 1/4-28UNF	0.5
5/8	UC202-10											M6×0.75 1/4-28UNF	
17	UC203											M6×0.75 1/4-28UNF	0.2
3/4	UC204-12	12.8 2878	6.65 1495	47 1.850	16 0.630	31 1.220	5 0.197	3.9 0.153	12.7 0.500	18.3 0.720	1 0.039	M6×0.75 1/4-28UNF	0.5
20	UC204											M6×0.75 1/4-28UNF	
7/8	UC205-14											M6×0.75 1/4-28UNF	0.2
25	UC205	14 3147	7.85 1765	52 2.047	17 0.669	34.1 1.343	5.5 0.217	4.5 0.177	14.3 0.563	19.8 0.780	1 0.039	M6×0.75 1/4-28UNF	0.5
15/16	UC205-15											M6×0.75 1/4-28UNF	
1	UC205-16											M6×0.75 1/4-28UNF	
1 1/8	UC206-18											M6×0.75 1/4-28UNF	0.3
30	UC206	19.5 4385	11.3 2540	62 2.441	19 0.748	38.1 1.500	6 0.236	5 0.197	15.9 0.626	22.2 0.874	1 0.039	M6×0.75 1/4-28UNF	0.7
1 3/16	UC206-19											M6×0.75 1/4-28UNF	
1 1/4	UC206-20											M6×0.75 1/4-28UNF	
1 1/4	UC207-20											5/16-24UNF	
1 15/16	UC207-21	25.7 5778	15.4 3462	72 2.835	20 0.787	42.9 1.689	6.5 0.256	5.7 0.224	17.5 0.689	25.4 1.000	1.1 0.043	5/16-24UNF	0.5
1 3/8	UC207-22											5/16-24UNF	1.1
35	UC207											M8×1 5/16-28UNF	
1 7/16	UC207-23											M8×1 5/16-28UNF	
1 1/2	UC208-24	29.1 6542	17.8 4002	80 3.150	21 0.827	49.2 1.937	8 0.315	5.9 0.232	19 0.748	30.2 1.189	1.1 0.043	5/16-24UNF	0.7
1 9/16	UC208-25											5/16-24UNF	1.5
40	UC208											M8×1 5/16-24UNF	
1 5/8	UC209-26											5/16-24UNF	
1 11/16	UC209-27	34.1 7666	21.3 4788	85 3.346	22 0.866	49.2 1.937	8 0.315	6 0.236	19 0.748	30.2 1.189	1.1 0.043	5/16-24UNF	0.8
1 3/4	UC209-28											5/16-24UNF	1.8
45	UC209											M8×1	

Continued on next page.

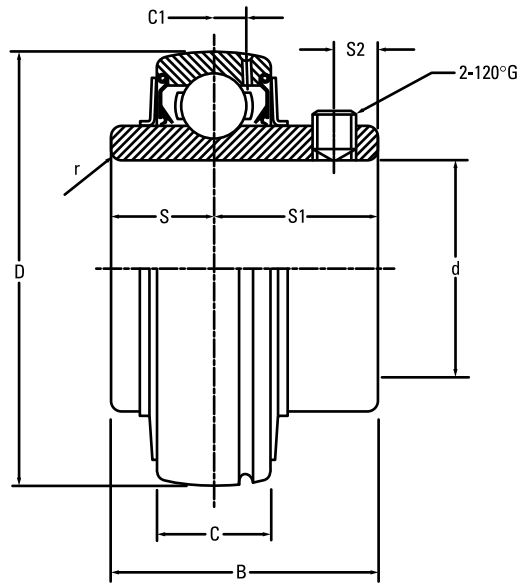

Continued from previous page.

Shaft Dia. d	Bearing Designation	Basic Load Ratings		Dimensions								Min. Fillet Radius r (min.)	Set Screw Size G	Weight
		Dynamic C _r	Static C _{0r}	D	C	B	S2	C1	S	S1				
mm in.		kN lbs.	kN lbs.	mm in.	mm in.	mm in.	mm in.	mm in.	mm in.	mm in.	mm in.	mm in.	mm in.	kg lbs.
50	1 7/8 UC210-30	35.1 7891	23.3 5238	90 3.543	24 0.945	51.6 2.031	9 0.354	6 0.236	19 0.748	32.6 1.283	1.1 0.043	3/8-24UNF	0.9	
	1 15/16 UC210-31											3/8-24UNF		
	UC210											M10x1.25		
55	2 UC210-32	43.4 9757	29.4 6609	100 3.937	25 0.984	55.6 2.189	9 0.354	7 0.276	22.2 0.874	33.4 1.315	1.5 0.059	3/8-24UNF	2.8	
	2 UC211-32											3/8-24UNF		
	2 1/8 UC211-34											3/8-24UNF		
60	2 3/16 UC211-35	52.4 11780	36.2 8138	110 4.331	27 1.063	65.1 2.563	10.5 0.413	7.4 0.291	25.4 1.000	39.7 1.563	1.5 0.059	M10x1.25	1.7	
	UC211											3/8-24UNF		
	2 1/4 UC212-36											3/8-24UNF		
65	2 7/16 UC212-38	57.2 12859	40.1 9015	120 4.724	28 1.102	65.1 2.563	12 0.472	7.5 0.295	25.4 1.000	39.7 1.563	1.5 0.059	1/2-20UNF	1.9	
	UC212											M12x1.5		
	2 3/8 UC212-39											1/2-20UNF		
70	2 1/2 UC213-40	62.2 13983	44.1 9914	125 4.921	30 1.181	74.6 2.937	12 0.472	9 0.354	30.2 1.189	44.4 1.748	1.5 0.059	1/2-20UNF	2.1	
	UC213											M12x1.5		
	2 3/4 UC214-44											1/2-20UNF		
75	UC214	67.4 15152	48.3 10858	130 5.118	32 1.260	77.8 3.063	12 0.472	9 0.354	33.3 1.311	44.5 1.752	1.5 0.059	1/2-20UNF	2.2	
	UC215											M12x1.5		
	3 UC215-48											1/2-20UNF		
80	3 1/8 UC216-50	72.7 16344	53 11915	140 5.512	33 1.299	82.6 3.252	14 0.551	8.9 0.350	33.3 1.311	49.3 1.941	2 0.079	1/2-20UNF	2.8	
	UC216											M12x1.5		
	3 1/4 UC216-52											1/2-20UNF		
85	UC217	84 18884	61.9 13916	150 5.906	35 1.378	85.7 3.374	14 0.551	9.8 0.386	34.1 1.343	51.6 2.031	2 0.079	1/2-20UNF	3.7	
	UC218											M12x1.5		
	3 1/2 UC218-56											1/2-20UNF		
90	UC218	96.1 21604	71.5 16074	160 6.299	38 1.496	96 3.780	15 0.591	11.1 0.437	39.7 1.563	56.3 2.217	2 0.079	M12x1.5	4.5 9.9	

TIMKEN OFFERS A WIDE RANGE OF HOUSED UNITS THAT HANDLE DEMANDING INDUSTRIAL OPERATIONS

INDUSTRIES AND APPLICATIONS

- Power Generation (Coal)
- Mining
- Aggregate/Cement
- Metal Mills
- Pulp and Paper/Sawmills/Forestry
- Water Treatment
- Food and Beverage Processing
- Warehousing
- Movable Bridges/Structures
- Industrial Fans/Blowers

Timken offers a full line of split- and solid-block housed units for every type of equipment. Easily interchangeable with industry standard designs, the Timken global distribution network makes it easy to get Timken products anywhere in the world – fast.



SNT PLUMMER BLOCKS
**Customizable Solution,
 Uptime Efficiency**

Timken® SNT Plummer Blocks provide excellent bearing protection with cast-iron housings and a variety of sealing options to help keep grease in and contamination out.



SAF PILLOW BLOCKS
**Optimal Load Capacity,
 Extended Service Life**

Timken® SAF Pillow Block split-block housed units combine high-performance spherical roller bearings with strong housings to meet the challenges of heavy industry.



**SPHERICAL ROLLER BEARING
 SOLID-BLOCK HOUSED UNITS**
**Heavy-duty Protection,
 High Performance**

Timken® spherical roller bearing solid-block housed units feature rugged cast steel housings, precision-made bearings, and a wide range of shaft-locking options and durable seals. Tough enough to handle extremely harsh conditions.



**TYPE E TAPERED ROLLER
 BEARING HOUSED UNITS**
**Improved Reliability,
 Enhanced Performance**

Timken® Type E tapered roller bearing housed units offer a significantly longer design life compared to current industry-leading designs utilizing standard Timken bearings.



**BALL BEARING
 HOUSED UNITS**
**Easy Installation,
 Flexible Options**

Timken® ball bearing housed units are available in a wide variety of types and sizes to accommodate a complete range of industrial applications and operating conditions.

CALL ON TIMKEN

For your nearest Timken sales representative,
visit www.timken.com.



TIMKEN

The Timken team applies their know-how to improve the reliability and performance of machinery in diverse markets worldwide. The company designs, makes and markets high-performance mechanical components, including bearings, gears, chain and related mechanical power transmission products and services.

www.timken.com

Stronger. Commitment. Stronger. Value. Stronger. Worldwide. Stronger. Together. | Stronger. By Design.