

# RIDUTTORI A VITE SENZA FINE

X - SERIES WORM GEARBOXES  
ЧЕРВЯЧНЫЕ РЕДУКТОРЫ X



X

MADE IN ITALY



# MADE IN ITALY

Per TRAMEC l'espressione "MADE IN ITALY" possiede un significato molto più profondo di quanto gli venga attribuito nell'uso comune. Tutti i prodotti di TRAMEC sono infatti il risultato di :

## PROGETTAZIONE E CREATIVITA' ITALIANA

Ogni riduttore della gamma TRAMEC è completamente progettato in ITALIA, nella sede principale di CALDERARA di RENO (BOLOGNA), nel cuore della cosiddetta "MOTOR VALLEY" e "PACKAGING VALLEY", un territorio dove la meccanica è da sempre protagonista. Qui gli ingegneri TRAMEC esprimono al meglio la creatività ITALIANA, avvalendosi di strumenti sempre più evoluti per progettare riduttori innovativi e personalizzabili in base a specifiche esigenze del cliente.

## PRODUZIONE E MONTAGGIO

Tutti i componenti principali dei riduttori TRAMEC vengono realizzati dalla rete produttiva della nostra Azienda, che si avvale anche dell'esperienza e delle capacità di artigiani selezionati presenti sul medesimo territorio.

Dall'assemblaggio di tali componenti, eseguito con perizia dai nostri tecnici esperti, nascono i riduttori TRAMEC.

Il risultato è un prodotto di altissima qualità, come quelli descritti nel catalogo che state sfogliando.

## SERVIZIO AL CLIENTE

L'importanza che TRAMEC attribuisce ai propri clienti non si riflette solamente nel fornire un prodotto di elevata qualità, ma anche nel garantire un'assistenza PRE e POST-VENDITA all'altezza del prodotto fornito.

In questo modo, curando al massimo la qualità dei prodotti e rimanendo costantemente al fianco del Cliente, si esprime a pieno l'ITALIANITA' della nostra Azienda.

Ecco cosa significa per TRAMEC l'espressione "MADE IN ITALY".

---

At TRAMEC "MADE IN ITALY" is an expression with a much deeper meaning , as all TRAMEC products are the result of :

## ITALIAN DESIGN & CREATIVITY

TRAMEC is headquartered in CALDERARA di RENO (BOLOGNA), in the heart of Italy's famous "MOTOR VALLEY" or "PACKAGING VALLEY" where the art of performance is mastered with the science of precision.

Italian design & engineering creativity is expressed via the most advanced tools by TRAMEC engineers in the design of our standard and customized products. This creativity results in an innovative design of remarkable quality which is presented in the catalogue before you.

## PRODUCTION & ASSEMBLY

The designs of TRAMEC are brought to life through the careful hands of machinists and technicians expressing the local tradition of excellence. All major components are produced , assembled , and inspected within the TRAMEC manufacturing organization.

From this long tradition, expressing performance and precision into objects of exceptional quality , we introduce the TRAMEC'S GEARBOXES.

## CUSTOMER CARE

Everything we do, from conception to delivery, is focused upon our customers. High performance precision products made to increasingly demanding levels of quality deserve excellence before, during and after the purchase

At TRAMEC we express our Italian culture and heritage in caring for our customers throughout the process.

From everyone at TRAMEC, this is what it means to say "MADE IN ITALY".

---

Для компании TRAMEC фраза "СДЕЛАНО В ИТАЛИИ" имеет более глубокое значение, чем в повседневном общении. Все изделия компании TRAMEC это результат:

## ИТАЛЬЯНСКОЙ РАЗРАБОТКИ И КРЕАТИВНОСТИ

Каждый редуктор серии TRAMEC полностью спроектирован в ИТАЛИИ, в главном офисе г. КАЛЬДЕРАРА-ДИ-РЕНО (провинция г.БОЛОНЬИ), в самом сердце так называемых «MOTOR VALLEY» и «PACKAGING VALLEY», территории, где механика всегда была главным действующим лицом. Здесь инженеры компании TRAMEC наилучшим образом выражают итальянскую креативность, используя все более совершенные инструменты для разработки инновационных редукторов, которые можно персонализировать с учетом конкретных потребностей клиентов.

## ПРОИЗВОДСТВО И СБОРКА

Все основные компоненты редукторов TRAMEC выпускаются производственной сетью нашей компании, которая также пользуется опытом и навыками отдельных отобранных мастеров этого же региона.

В результате сборки редукторов из оригинальных компонентов, выполненной под контролем наших технических экспертов, появляются на свет редукторы TRAMEC.

Результатом является изделие высочайшего качества, которые приведены в данном каталоге.

## НА СЛУЖБЕ У КЛИЕНТА

Внимание, которое компания TRAMEC уделяет своим клиентам, выражается не только в предоставлении высококачественной продукции, но и в предоставлении ПРЕД и ПОСЛЕПРОДАЖНОЙ поддержки на таком же высоком уровне.

Таким образом, максимальная забота о качестве продукции и постоянная поддержка клиента отражают ИТАЛЬЯНСКУЮ СУЩНОСТЬ нашей Компании.

Вот что значит для компании TRAMEC выражение "СДЕЛАНО В ИТАЛИИ".





INDICE		INDEX	СОДЕРЖАНИЕ	
<b>1.0</b>	<b>GENERALITA'</b>	<b>GENERAL INFORMATION</b>	<b>ОБЩИЕ СВЕДЕНИЯ</b>	<b>2</b>
1.1	Unità di misura	<i>Measurement units</i>	Единицы измерения	3
1.2	Potenza	<i>Power</i>	Мощность	3
1.3	Rapporto di riduzione	<i>Reduction Ratio</i>	Передаточное число	3
1.4	Momento torcente	<i>Torque</i>	Крутящий момент	3
1.5	Fattore di servizio	<i>Service factor</i>	Сервис-фактор	4
1.6	Rendimento	<i>Efficiency</i>	Производительность	5
1.7	Irreversibilità	<i>Irreversibility</i>	Нереверсивность	6
1.8	Gioco angolare	<i>Backlash</i>	Угловой зазор	7
1.9	Senso di rotazione	<i>Direction of rotation</i>	Направление вращения	8
1.10	Carichi radiali	<i>Radial load</i>	Радиальные нагрузки	8
1.11	Potenza termica	<i>Thermal power</i>	Тепловая мощность	11
1.12	Selezione	<i>Selection</i>	Выбор	11
1.13	Lubrificazione	<i>Lubrication</i>	Смазывание	12
1.14	Installazione	<i>Installation</i>	Установка	14
1.15	Manutenzione	<i>Maintenance</i>	Техобслуживание	14
1.16	Verniciatura	<i>Painting</i>	Окраска	14
	<b>RIDUTTORI A VITE SENZA FINE X</b>	<b>2.0</b> <b>X WORM GEARBOXES</b>	<b>ЧЕРВЯЧНЫЕ РЕДУКТОРЫ X</b>	<b>15</b>

## 1.0 Generalità

TRAMEC presenta sul mercato con la gamma di riduttori a vite senza fine con le seguenti serie:

## 1.0 General information

*TRAMEC has introduced on the market a range of worm gearboxes available as follows:*

## 1.0 Общие сведения

Компания TRAMEC поставляет на рынок гамму червячных редукторов следующих серий:

### Serie X

Riduttore a vite senza fine con corpo monolitico caratterizzato da una alta modularità di fissaggio grazie alla lavorazione in tolleranza di tutti i piani di appoggio.

### Series X

*Worm gearbox with monolithic body. Thanks to tolerance machining of all faces, the X series stands out for its high modularity of fastening options.*

### Серия X

Червячный редуктор в монолитном корпусе, который отличается высокой модульностью крепления, благодаря обработке в пределах допуска всех опорных поверхностей.



### 1.1 Unità di misura

### 1.1 Measurement units

### 1.1 Единицы измерения

Simbolo Symbol Обозначение	Unità di misura Measurement unit Единица измерения	Definizione	Definition	Определение
FS'		Fattore di servizio riduttore	<i>Gearbox service factor</i>	Сервис-фактор редуктора
FS		Fattore di servizio dell'applicazione	<i>Application service factor</i>	Сервис-фактор применения
$i_1$		Rapporto di riduzione del 1° riduttore	<i>Ratio of 1st gearbox</i>	Передаточное число 1го редуктора
$i_2$		Rapporto di riduzione del 2° riduttore	<i>Ratio of 2nd gearbox</i>	Передаточное число 2го редуктора
$i_n$		Rapporto di riduzione	<i>Reduction ratio</i>	Передаточное число
$M_{2S}$	[Nm/Hm]	Coppia di slittamento	<i>Slipping torque</i>	Момент скольжения
$n_1$	[min <sup>-1</sup> /мин <sup>-1</sup> ]	Giri in entrata	<i>Input speed</i>	Обороты на входе
$n_2$	[min <sup>-1</sup> /мин <sup>-1</sup> ]	Giri in uscita	<i>Output speed</i>	Обороты на выходе
P	[kW/кВт]	Potenza riduttore	<i>Gearbox capacity</i>	Мощность редуктора
P'	[kW/кВт]	Potenza richiesta in entrata	<i>Power required at input</i>	Требуемая мощность на входе
$P_1$	[kW/кВт]	Potenza motoriduttore	<i>Gear motor power</i>	Мощность мотор-редуктора
$P_2$	[kW/кВт]	Potenza in uscita	<i>Output power</i>	Мощность на выходе
$P_{1c}$	[kW/кВт]	Potenza termica corretta	<i>Corrected thermal power</i>	Откорректированная тепловая мощность
$P_{10}$	[kW/кВт]	Potenza termica nominale	<i>Thermal power</i>	Номинальная тепловая мощность
$F_{r1}$	[N/H]	Carico radiale albero entrata	<i>Input shaft radial load</i>	Радиальная нагрузка входного вала
$F_{r2}$	[N/H]	Carico radiale albero uscita	<i>Output shaft radial load</i>	Радиальная нагрузка выходного вала
$F_{a1}$	[N/H]	Carico assiale albero entrata	<i>Input shaft axial load</i>	Осевая нагрузка входного вала
$F_{a2}$	[N/H]	Carico assiale albero uscita	<i>Output shaft axial load</i>	Осевая нагрузка выходного вала
Rd		Rendimento dinamico	<i>Dynamic efficiency</i>	Динамический КПД
Rs		Rendimento statico	<i>Static efficiency</i>	Статический КПД
Ta	[°C]	Temperatura ambiente	<i>Ambient temperature</i>	Температура окружающей среды
$T_{2M}$	[Nm/Hm]	Momento torcente riduttore	<i>Gearbox torque</i>	Крутящий момент редуктора
$T_2$	[Nm/Hm]	Momento torcente motoriduttore	<i>Gear motor torque</i>	Крутящий момент мотор-редуктора
$T_C$	[Nm/Hm]	Momento torcente da utilizzare per la scelta del riduttore	<i>Torque to be used for the selection of the gearbox</i>	Крутящий момент, используемый для выбора редуктора
$T_2'$	[Nm/Hm]	Momento torcente richiesto	<i>Required Torque</i>	Требуемый крутящий момент

### 1.2 Potenza

P = Potenza massima applicabile in entrata con vite ad albero maschio riferita alla velocità  $n_1$  con un fattore di servizio FS = 1 e a un servizio continuo S1.

$P_1$  = Potenza motore consigliata riferita alla velocità  $n_1$  con il fattore di servizio FS riportato in tabella a pag. 4 e a servizio continuo S1.

E' possibile determinare la potenza necessaria in entrata P' in base alla coppia  $T_2'$  richiesta all'applicazione secondo la seguente formula:

### 1.2 Power

P = max. power applicable at input with male worm shaft, referred to  $n_1$  speed, service factor FS=1, on S1 continuous duty.

$P_1$  = recommended motor power, referred to  $n_1$  speed, service factor FS as reported in the table on page 4, on S1 continuous duty.

The necessary input power with regard to  $T_2$  torque required by the application, is to be calculated with the following formula:

$$P' = \frac{T_2' \cdot n_2}{9550 \cdot Rd} \quad [kW]$$

### 1.2 Мощность

P = максимальная мощность применимая на входе в исполнении со сплошным входным валом, относящаяся к скорости n с сервис-фактором FS = 1 при непрерывной работе S1.

$P_1$  = Рекомендуемая мощность двигателя, относящаяся к скорости n с сервис-фактором FS, приведенном в таблице на стр. 4, при непрерывной работе S1

Можно определить необходимую мощность на входе P' на основании крутящего момента  $T_2'$ , требуемого при определенном применении, по следующей формуле:

### 1.3 Rapporto di riduzione

$i_n$  = È il rapporto di riduzione della velocità, definito come:

### 1.3 Reduction Ratio

$i_n$  = speed reduction ratio, defined as follows:

$$i_n = \frac{n_1}{n_2}$$

### 1.3 Передаточное число

$i_n$  = Передаточное число скорости, определенное следующим образом:

### 1.4 Momento torcente

$T_{2M}$  = È la massima coppia trasmissibile in uscita del riduttore con carico uniforme riferito alla velocità  $n_1$  con un fattore di servizio FS = 1 e a servizio continuo S1.

$T_2$  = È la coppia in uscita del motoriduttore riferita alla velocità  $n_1$  alla potenza  $P_1$ , con il fattore di servizio FS riportato in tabella e a servizio continuo S1.

### 1.4 Torque

$T_{2M}$  = max. torque transmissible at gearbox output with uniform load, referred to  $n_1$  speed, service factor FS = 1, on S1 continuous duty.

$T_2$  = output torque transmissible to the geared motor, referred to  $n_1$  speed,  $P_1$  power, FS service factor as reported in the table, on S1 continuous duty.

$$T_{2M} = \frac{9550 \cdot P_1 \cdot Rd}{n_2} \quad [Nm]$$

### 1.4 Крутящий момент

$T_{2M}$  = это максимальный передаваемый крутящий момент на выходе редуктора с равномерной нагрузкой, относящейся к скорости  $n_1$  с сервис-фактором FS = 1 и при непрерывной работе S1.  $T_2$  = Это крутящий момент на выходе мотор-редуктора, относящийся к скорости  $n_1$  при мощности  $P_1$ , с сервис-фактором FS, приведенным в таблице, при непрерывной работе S1.

### 1.5 Fattore di servizio FS

È il valore che tiene in considerazione le varie condizioni di funzionamento:

- tipologia di applicazione ovvero natura del carico (A-B-C)
- durata di funzionamento (ore giornaliere h/gg)
- numero di avviamenti/ora

Il coefficiente così trovato (FS) dovrà essere uguale o inferiore al fattore di servizio del riduttore da adottare FS' dato dal rapporto tra la coppia  $T_{2M}$  indicata a catalogo e la coppia  $T_2$  richiesta dall'applicazione.

### 1.5 FS Service factor

Value which takes the different operating conditions into consideration:

- type of application or type of load (A-B-C)
- length of operation (hours per day h/d)
- number of start-ups/hour

This coefficient (FS) will have to be equal or lower than the FS of selected gearbox FS' given by the ratio between  $T_{2M}$  torque mentioned in the catalogue and the  $T_2$  torque required by the application.

### 1.5 Сервис-фактор FS

Это значение учитывает разные рабочие условия:

- тип применения или тип нагрузки (A-B-C)
- длительность работы (часы работы ч/дд)
- количество запусков/час

Найденный таким образом коэффициент (FS) должен быть равен или меньше, чем фактор-сервис используемого редуктора FS', определяемый соотношением между крутящим моментом  $T_{2M}$ , указанным в каталоге, и крутящим моментом  $T_2$ , требуемым для применения.

$$FS' = \frac{T_{2M}}{T_2} > FS$$

I valori di FS indicati in tabella sono relativi all'azionamento del motore elettrico; se utilizzato un motore a scoppio, si dovrà tenere conto di un fattore di moltiplicazione 1.3 se a più cilindri e 1.5 se monocilindrico. Se il motore elettrico applicato è autofrenante occorre considerare un numero di avviamenti doppio di quello effettivamente richiesto.

FS values reported in the table refer to the electric motor operation; should a combustion motor be used, consider a multiplication factor of 1.3 for a multicylinder motor, of 1.5 for a single-cylinder one. If an electric brake motor is used, consider a number of start-ups which is twice as much the number actually required.

Значения FS, указанные в таблице, относятся к приводу электродвигателя; если используется двигатель внутреннего сгорания, при нескольких цилиндрах должен учитываться коэффициент умножения 1,3, а при одном цилиндре - 1,5. Если установлен самотормозящийся электродвигатель, следует учитывать удвоенное количество требуемых запусков.

Classe di carico Load class Класс нагрузки	h/gg h/d ч/дд	N. AVVIAMENTI/ORA / N. START-UP/HOUR / КОЛИЧЕСТВО ЗАПУСКОВ/ЧАС									
		2	4	8	16	32	63	125	250	500	
<b>A</b>	4	0.8	0.8	0.9	0.9	1.0	1.1	1.1	1.2	1.2	
	8	1.0	1.0	1.1	1.1	1.3	1.3	1.3	1.3	1.3	
	16	1.3	1.3	1.3	1.3	1.5	1.5	1.5	1.5	1.5	
	24	1.5	1.5	1.5	1.5	1.8	1.8	1.8	1.8	1.8	
	<b>APPLICAZIONI / APPLICATIONS / ПРИМЕНЕНИЯ</b>										
<b>Carico uniforme Uniform load Равномерная нагрузка</b>		Agitatori per liquidi puri Alimentatori per forncaci Alimentatori a disco Filtri di lavaggio con aria Generatori Pompe centrifughe Trasportatori con carico uniforme	Pure liquid agitators Furnace feeders Disc feeders Air laundry filters Generators Centrifugal pumps Uniform load conveyors	Smesiteleri для чистой жидкости Питатели для печей Дисковые питатели Фильтры с воздушной промывкой Генераторы Центробежные насосы Конвейеры с равномерной нагрузкой							
<b>B</b>	4	1.0	1.0	1.0	1.0	1.3	1.3	1.3	1.3	1.3	
	8	1.3	1.3	1.3	1.3	1.5	1.5	1.5	1.5	1.5	
	16	1.5	1.5	1.5	1.5	1.8	1.8	1.8	1.8	1.8	
	24	1.8	1.8	1.8	1.8	2.2	2.2	2.2	2.2	2.2	
	<b>APPLICAZIONI / APPLICATIONS / ПРИМЕНЕНИЯ</b>										
<b>Carico con urti moderati Moderate shock load Нагрузка с умеренными толчками</b>		Agitatori per liquidi e solidi Alimentatori a nastro Argani con medio servizio Filtri con pietre e ghiaia Viti per espulsione acqua Flocculatori Filtri a vuoto Elevatori a tazze Gru	Liquid and solid agitators Belt conveyors Medium service winches Stone and gravel filters Dewatering screws Flocculator Vacuum filters Bucket elevators Cranes	Smesiteleri для жидких и твёрдых фракций Ленточные питатели Лебёдки со средней нагрузкой Фильтры с камнями и гравием Обезвоживающие винты Флокуляторы (хлопьеобразователь) Вакуумные фильтры Ковшовые подъёмники Подъёмный кран							
<b>C</b>	4	1.3	1.3	1.3	1.3	1.5	1.5	1.5	1.5	1.5	
	8	1.5	1.5	1.5	1.5	1.8	1.8	1.8	1.8	1.8	
	16	1.8	1.8	1.8	1.8	2.2	2.2	2.2	2.2	2.2	
	24	2.2	2.2	2.2	2.2	2.5	2.5	2.5	2.5	2.5	
	<b>APPLICAZIONI / APPLICATIONS / ПРИМЕНЕНИЯ</b>										
<b>Carico con urti forti Heavy shock load Нагрузка с сильными толчками</b>		Argani per servizio pesante Estrusori Calandre per gomma Presse per mattoni Piattatrici Mulini a sfera	Heavy duty hoists Extruders Crusher rubber calenders Brick presses Planing machine Ball mills	Лебёдки для критических условий Экструдеры Каландры для резины Прессы для кирпичей Строгальные станки Шаровые мельницы							

### 1.6 Rendimento

**Rd** - È il rendimento dinamico, definito come rapporto tra la potenza in uscita  $P_2$  e quella in entrata  $P_1$ . Dipende principalmente dalla velocità di strisciamento, dal tipo di lubrificante e dall'angolo d'elica. I valori indicati nelle tabelle sono validi se si applica la corrispondente coppia in uscita. In fase di rodaggio, circa le prime 300 ore di funzionamento sotto carico, il valore deve essere considerato inferiore del 30% rispetto a quello indicato in tabella.

**Rs** - È il rendimento statico che si ha al momento dell'avviamento del riduttore e varia in base al rapporto di riduzione. Risulta importante, per una corretta valutazione del riduttore da impiegare, nelle applicazioni in cui non si raggiungono mai le condizioni di regime come nei funzionamenti intermittenti. Analogamente al caso dinamico, anche il rendimento statico durante il rodaggio risulta inferiore del 30% rispetto al valore indicato in tabella.

### 1.6 Efficiency

**Rd** - dynamic efficiency, defined as the ratio between  $P_2$  output power and  $P_1$  input power. It mainly depends on the slipping speed, the type of lubricant and the lead angle. The values reported in the table are valid when the corresponding output torque is applied. During the first 300 operating hours under load, the value to be considered is 30% lower than that reported in the table.

**Rs** - static efficiency at gearbox start-up; it changes depending on the reduction ratio. Rs value is important for selecting the right gearbox for applications where a steady state is never achieved, as for intermittent duty applications. Same as dynamic efficiency, static efficiency too during the running-in period will be 30% lower than the value reported in the table.

### 1.6 Производительность

**Rd** - Это динамическая производительность, определяемая как соотношение мощности на выходе  $P_2$  и на входе  $P_1$ . Зависит главным образом от скорости скольжения, от типа смазки и от угла винта. Указанные в таблицах значения действительны, если применяется соответствующий крутящий момент на выходе. Во время фазы обкатки, примерно в первые 300 часов работы под нагрузкой, это значение следует считать на 30% ниже, чем указанное в таблице.

**Rs** - Это статическая производительность на момент запуска редуктора, которая меняется в зависимости от передаточного числа. Это важно для правильной оценки редуктора, требуемого в тех случаях, когда никогда не достигается рабочий режим, например при прерывистой работе. Как и для динамической производительности, статическая производительность в течение периода обкатки на 30% ниже значения, указанного в таблице.

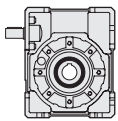

X	Rs											
	5	7.5	10	15	20	25	30	40	50	65	80	100
30	0.70	0.67	0.62	0.55	0.47	0.43	0.39	0.30	0.27	0.25	0.22	0.21
40	0.69	0.67	0.63	0.55	0.52	0.45	0.40	0.35	0.29	0.26	0.25	0.23
50	0.69	0.68	0.65	0.58	0.53	0.47	0.41	0.37	0.32	0.28	0.25	0.23
63	0.70	0.68	0.65	0.57	0.55	0.50	0.47	0.38	0.33	0.29	0.28	0.23
75	/	0.68	0.65	0.58	0.55	0.51	0.43	0.39	0.35	0.31	0.28	0.24
89	/	0.68	0.65	0.58	0.55	0.52	0.45	0.39	0.36	0.32	0.29	0.25
90	/	0.68	0.65	0.58	0.55	0.52	0.45	0.39	0.36	0.32	0.29	0.25
110	/	0.68	0.66	0.59	0.56	0.53	0.44	0.40	0.38	0.33	0.30	0.26
130	/	0.69	0.66	0.60	0.57	0.55	0.44	0.42	0.39	0.35	0.32	0.28

Stabilito il rapporto di riduzione necessario all'applicazione, dove è possibile, è consigliabile utilizzare i diversi tipi di riduttori che offrono, a parità di rapporto, un migliore rendimento dinamico.

Once the reduction ratio required by the application has been established, it is advisable to select a type of gearbox which, ratio being equal, offers better dynamic efficiency.

После определения необходимого для конкретного применения передаточного числа, по возможности, рекомендуется использовать редукторы, использовать редукторы разных типов, которые при одинаковом передаточном числе обеспечивают лучшую динамическую эффективность.



## 1.7 Irreversibilità

Nelle applicazioni dove è necessario evitare la trasmissione del moto retrogrado o sostenere il carico, in assenza di alimentazione elettrica, è consigliabile adottare freni esterni.

Nei riduttori a vite senza fine emerge questa caratteristica naturale, denominata grado di irreversibilità, che cresce con l'aumentare del rapporto di riduzione in quanto strettamente legata al relativo rendimento.

Per ottenere alti gradi di irreversibilità occorre quindi adottare i rapporti di riduzione più elevati, senza dimenticare che, il rendimento, tende a crescere durante le prime 500 ore di funzionamento per poi stabilizzarsi sui valori riportati a catalogo.

### Irreversibilità statica

Condizione di impedimento alla rotazione comandata dall'albero lento senza escludere possibili ritorni lenti nel caso in cui il carico sia sottoposto a vibrazioni.

$R_s < 0.45$  si ha irreversibilità  
 $R_s = 0.45 \div 0.55$  irreversibilità incerta  
 $R_s > 0.55$  si ha reversibilità

### Irreversibilità dinamica

Condizione di arresto e quindi di sostegno del carico nel momento in cui cessa l'azione di comando. La condizione è più difficile da ottenere in quanto viene influenzata dal rendimento dinamico, dalla velocità di rotazione, da eventuali vibrazioni che il carico può generare e dalla direzione del movimento rispetto al carico.

Quest'ultima condizione è molto evidente nei sollevamenti: un carico in salita, cessando l'azione di comando, deve arrestarsi e quindi assumere velocità zero (rendimento statico) prima di invertire il moto e cadere per gravità.

Un carico in discesa tende invece a proseguire nel suo moto ostacolato, nella caduta, dal solo rendimento dinamico.

$R_d < 0.45$  si ha irreversibilità  
 $R_d = 0.45 \div 0.55$  irreversibilità incerta  
 $R_d > 0.55$  si ha reversibilità

## 1.7 Irreversibility

*The use of external brakes is advised in case of applications where backwards motion must be hindered and the load must be held should the feed be cut off.*

*Some worm gearboxes feature natural irreversibility. The higher the ratio, the higher is the irreversibility, since it is strictly dependent on the relative efficiency.*

*In order to achieve high irreversibility it is therefore necessary to select higher efficiency reduction ratios not to forget that the efficiency is growing during the first 500 hours life until it stabilizes to the values mentioned in the catalogue.*

### Static irreversibility

*Static irreversibility occurs when the rotation controlled by the output shaft is hindered; possible slow returns cannot be excluded should the load be subject to vibrations.*

$R_s < 0.45$  provides irreversibility  
 $R_s = 0.45 \div 0.55$  irreversibility is uncertain  
 $R_s > 0.55$  reversibility is possible

### Dynamic irreversibility

*Dynamic irreversibility is characterized by stillstand and hold of the load when the drive stops. It is more difficult to achieve this condition because it is influenced by dynamic efficiency, speed of rotation and possible vibrations generated by the motion direction with regard to the load.*

*This last condition is much more evident during the lifting: if the drive stops during the lifting of the load this has to come to a speed equals to zero (static irreversibility) before the reversal of motion rotation and its drop for gravity.*

*On the contrary the load during its descent gets its motion obstructed by its dynamic efficiency.*

$R_d < 0.45$  provides irreversibility  
 $R_d = 0.45 \div 0.55$  irreversibility is uncertain  
 $R_d > 0.55$  reversibility is possible

## 1.7 Нереверсивность

В тех случаях, когда необходимо избежать передачи обратного движения или выдержать нагрузку при отсутствии электрической энергии, целесообразно использовать внешние тормоза.

В червячных редукторах выделяется эта естественная характеристика, называемая степенью нереверсивности, которая увеличивается с повышением передаточного числа, поскольку она тесно связана с относительной производительностью.

Поэтому для получения высокой степени нереверсивности необходимо применять самые высокие передаточные числа, не забывая, что эффективность имеет тенденцию увеличиваться в течение первых 500 часов работы, а затем стабилизироваться на значениях, показанных в каталоге.

### Статическая нереверсивность

Состояние полного сопротивления вращению, задаваемому медленным валом, без исключения возможных медленных возвратов в случае, если нагрузка подвергается вибрации.

$R_s < 0.45$  нереверсивность  
 $R_s = 0.45 \div 0.55$  нестабильная нереверсивность  
 $R_s > 0.55$  реверсивность

### Динамическая нереверсивность

Состояние остановки и следовательно, выдерживания груза на момент прекращения действия управления. Это состояние сложнее достичь, поскольку на него влияют динамические характеристики, скорость вращения, любые вибрации, которые может вырабатывать груз, и направление движения относительно груза.

Последнее условие очень заметно при подъемах: поднимаемый груз после прекращения управления должен остановиться и, следовательно, принять нулевую скорость (статическую производительность), перед сменой направления и падением под действием гравитационных сил. Груз на спуске имеет тенденцию продолжить движение, которому при падении препятствует только динамический КПД.

$R_d < 0.45$  нереверсивность  
 $R_d = 0.45 \div 0.55$  нестабильная нереверсивность  
 $R_d > 0.55$  реверсивность

### 1.8 Gioco angolare

### 1.8 Backlash

### 1.8 Угловой зазор

#### Gioco angolare standard

#### Standard Backlash

#### Стандартный угловой зазор

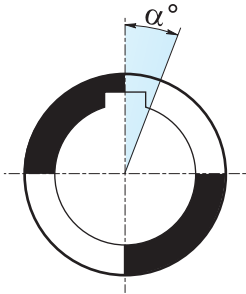

X									
$i_n$	30	40	50	63	75	89	90	110	130
	макс.	макс.	макс.	макс.	макс.	макс.	макс.	макс.	макс.
5	16'	13.5'	10.5'	10'	/	/	/	/	/
7.5	16'	13.5'	10.5'	10'	10'	9.5'	9.5'	8'	8'
10	16'	13.5'	10.5'	10'	10'	9'	9'	8'	8'
15	16'	13.5'	10.5'	10'	10'	9'	9'	8'	8'
20	14.5'	12'	9.5'	8.5'	8.5'	8.5'	8.5'	7'	8'
25	14.5'	12'	9.5'	8.5'	8.5'	8.5'	8.5'	7'	7'
30	14.5'	12'	8.5'	8.5'	8.5'	8.5'	8.5'	7'	7'
40	14.5'	12'	9.5'	8.5'	8.5'	8'	8'	7'	7'
50	14'	12'	9.5'	8.5'	8.5'	8'	8'	7'	7'
65	14'	12'	9'	8'	8'	8'	8'	7'	7'
80	13.5'	11.5'	9'	7.5'	7.5'	7.5'	7.5'	7'	7'
100	13'	11'	9'	7.5'	7.5'	7.5'	7.5'	7'	7'

Misurato bloccando l'albero entrata, e ruotando l'albero uscita nelle due direzioni applicando la coppia strettamente necessaria a creare il contatto tra i denti degli ingranaggi, al massimo pari al 2% della coppia nominale ( $T_{2M}$ ).

*Angular backlash measured after having blocked the input shaft by rotating output shaft in both directions and applying the torque which is strictly necessary to create a contact between the teeth of the gears. The applied torque should be at most 2% of the max. torque ( $T_{2M}$ ).*

Измеряется путем блокировки входного вала и поворота выходного вала в двух направлениях с применением крутящего момента, строго необходимого для создания контакта между зубьями шестерни, равного максимум 2% от номинального крутящего момента ( $T_{2M}$ ).

#### Gioco angolare ridotto

#### Reduced Backlash

#### Пониженный угловой зазор

I giochi angolari ridotti esposti in tabella si possono ottenere solo costruendo corone speciali. Da notare che l'usura dovuta al funzionamento rende la versione con gioco ridotto di durata limitata direttamente proporzionale al fattore di servizio ( $f_s$ ) dell'applicazione: più il riduttore è sovradimensionato e maggiore è la durata del gioco ridotto.

The reduced angular clearance shown in the table can only be obtained by building special crowns. It must be noted that the wear due to operation makes the version with reduced clearance of limited duration directly proportional to the service factor ( $f_s$ ) of the application: the more oversized the reducer, the longer the duration of the reduced backlash.

Пониженные угловые зазоры, приведённые в таблице, могут быть получены только с помощью специальных венцов. Следует отметить, что из-за износа в результате работы версия с уменьшенным зазором имеет ограниченную продолжительность, прямо пропорциональную сервис-фактору ( $f_s$ ) применения: чем больше типоразмер редуктора, тем больше продолжительность уменьшенного зазора.

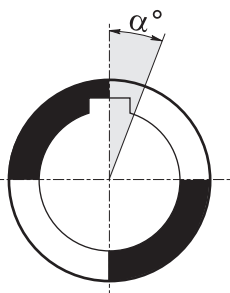

X									
$i_n$	30	40	50	63	75	89	90	110	130
	макс.	макс.	макс.	макс.	макс.	макс.	макс.	макс.	макс.
$5 \div 100$	7'	6'	5'	5'	4'	4'	4'	4'	4'

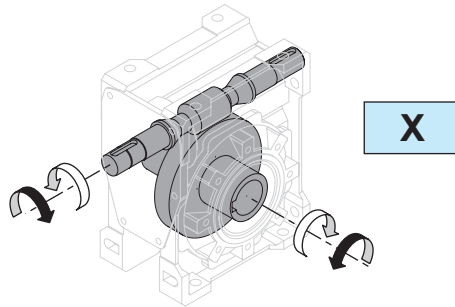

1.10 Carichi radiali

Ogni tipo di organo di trasmissione che viene collegato o sull'albero in entrata o in quello di uscita determina carichi radiali rispettivamente  $Fr_1$  e  $Fr_2$ .

I valori riportati in tabella in funzione delle varie velocità in entrata e in uscita sono da considerarsi applicabili come forza agente a metà della sporgenza; per un posizionamento a 1/3 della lunghezza occorre aumentare i valori di tabella del 25% mentre per un posizionamento a 2/3 della lunghezza occorre diminuire gli stessi valori del 25%.

I valori dei carichi assiali applicabili in entrata  $Fa_1$  e in uscita  $Fa_2$  sono indicati nelle tabelle.

Negli alberi bisporgenti, ogni estremità può sopportare un carico radiale pari ai 3/5 dei valori riportati in tabella purchè agiscano nello stesso senso e siano di pari intensità

Carichi radiali  $Fr_1$  e assiali  $Fa_1$  sull'albero entrata [N]

1.10 Radial load

Any transmission device coupled to either the input or to the output shaft generates radial loads,  $Fr_1$  and  $Fr_2$  respectively.

The load values reported in the table, depending on input and output speed, are to be considered as acting at the half-way point of the projection; if the load is applied at 1/3 of the projection, increase the values in the table by 25%; if the load is applied at 2/3, reduce the values by 25%.

Axial loads applicable at input  $Fa_1$  and at output  $Fa_2$  are reported in the tables.

With regard to double projecting shafts, each end can sustain a radial load which equals 3/5 of the values listed in the table, on condition that they act in the same direction and have the same intensity.

$Fr_1$  radial loads and  $Fa_1$  axial loads on the input shaft [N]

1.10 Радиальные нагрузки

Любой тип промышленной трансмиссии, подключаемый к выходному валу, влияет на радиальные нагрузки  $Fr_1$  и  $Fr_2$ .

Значения, показанные в таблице в соответствии с различными входящими и исходящими скоростями, следует считать применимыми как сила, действующая в центре выступа; для позиционирования на 1/3 длины необходимо увеличить значения таблицы на 25%, в то время как для позиционирования на 2/3 длины необходимо уменьшить эти значения на 25%.

Значения осевой нагрузки, применяемой на входе  $Fa_1$  и на выходе  $Fa_2$  приводятся в таблицах.

На двухконцевых валах каждый конец может выдерживать радиальную нагрузку, равную 3/5 от значений, указанных в таблице, при условии, что они действуют в том же направлении и имеют одинаковую интенсивность

Радиальные  $Fr_1$  и осевые нагрузки  $Fa_1$  входного вала [H]

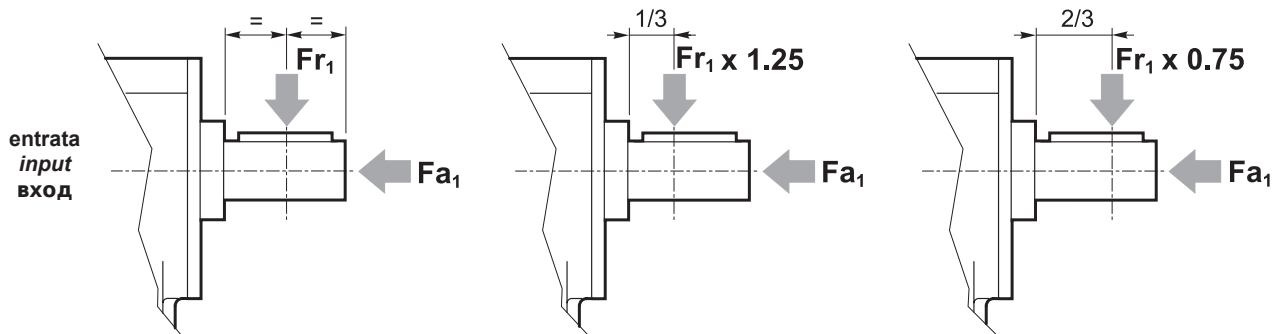

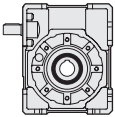

n <sub>1</sub> [мин-1]	XA30		XA40		XA50		XA63		XA75		XA90		XA110		XA130	
	Fr <sub>1</sub>	Fa <sub>1</sub>	Fr <sub>1</sub>	Fa <sub>1</sub>	Fr <sub>1</sub>	Fa <sub>1</sub>	Fr <sub>1</sub>	Fa <sub>1</sub>	Fr <sub>1</sub>	Fa <sub>1</sub>	Fr <sub>1</sub>	Fa <sub>1</sub>	Fr <sub>1</sub>	Fa <sub>1</sub>	Fr <sub>1</sub>	Fa <sub>1</sub>
1400	100	20	220	44	400	80	480	96	750	150	850	170	1200	240	1500	300

Carichi radiali Fr<sub>2</sub> e assiali Fa<sub>2</sub> sull'albero uscita [N]

Fr<sub>2</sub> radial loads and Fa<sub>2</sub> axial loads on the output shaft [N]

Радиальные Fr<sub>2</sub> и осевые нагрузки Fa<sub>2</sub> выходного вала [Г]

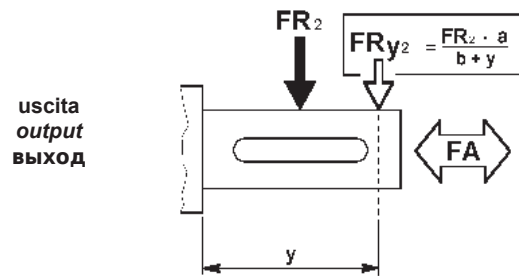

CUSCINETTI RADIALI A SFERE / RADIAL BALL BEARINGS / РАДИАЛЬНЫЕ ШАРИКОВЫЕ ПОДШИПНИКИ																			
n <sub>1</sub> =1400 об/мин		30	40	50	63	75	89	90	110	130									
i <sub>n</sub>	n <sub>2</sub> [об/мин]	a = 66.5 b = 49		a = 83.5 b = 60.5		a = 102 b = 73.5		a = 122.5 b = 93.5		a = 134 b = 100		a = 163 b = 118		a = 163 b = 118		a = 179.5 b = 131.5		a = 190 b = 145	
		Fr <sub>2</sub>	Fa <sub>2</sub>	Fr <sub>2</sub>	Fa <sub>2</sub>	Fr <sub>2</sub>	Fa <sub>2</sub>	Fr <sub>2</sub>	Fa <sub>2</sub>	Fr <sub>2</sub>	Fa <sub>2</sub>	Fr <sub>2</sub>	Fa <sub>2</sub>	Fr <sub>2</sub>	Fa <sub>2</sub>	Fr <sub>2</sub>	Fa <sub>2</sub>	Fr <sub>2</sub>	Fa <sub>2</sub>
5	280	700	140	1400	280	1400	300	1800	360	/	/	/	/	/	/	/	/	/	/
7.5	187	750	150	1500	300	1650	330	2100	420	2500	500	2600	520	2600	520	3500	700	5100	1020
10	140	800	160	1600	320	1800	360	2300	460	2800	560	3000	600	3000	600	3800	760	5600	1120
15	93	850	170	1700	340	1950	390	2600	520	3000	600	3400	680	3400	680	4200	840	6400	1280
20	70	900	180	1800	360	2200	440	2800	560	3300	660	3800	760	3800	760	4600	920	7000	1400
25	56	950	190	1900	380	2400	480	3100	620	3700	740	4100	820	4100	820	5100	1020	7600	1520
30	47	1000	200	2000	400	2600	520	3400	680	4000	800	4500	900	4500	900	5600	1120	8050	1610
40	35	1050	210	2100	420	2850	570	3700	740	4400	880	4900	980	4900	980	6100	1220	8800	1760
50	28	1100	220	2200	440	3100	620	4000	800	4850	970	5300	1060	5300	1060	6700	1340	9500	1900
60	23	1150	230	2400	480	3200	640	4200	840	5000	1000	5600	1120	5600	1120	7100	1420	9800	2000
63	22	1250	250	2500	500	3400	680	4450	890	5300	1060	5900	1180	5900	1180	7400	1480	10100	2020
80	17.5	1350	270	2700	540	3800	760	4900	980	5800	1160	6500	1300	6500	1300	8100	1620	11200	2240
100	14	1500	300	3000	600	4000	800	5400	1080	6500	1300	7000	1400	7000	1400	8500	1700	12050	2410
120	11.7	1520	304	3100	620	4100	820	5500	1100	6550	1310	7100	1420	7100	1420	8800	1760	12200	2500
150	9.3	1550	310	3150	630	4250	850	5600	1120	6600	1320	7300	1460	7300	1460	9100	1820	12500	2600
160	8.8	1570	314	3200	640	4300	860	5700	1140	6700	1340	7400	1480	7400	1480	9200	1840	12800	2650
≥ 200	≤ 7.0	1600	320	3300	660	4500	900	6000	1200	7100	1420	7900	1580	7900	1580	10000	2000	13000	2800

### Versioni rinforzate

A richiesta vengono fornite versioni rinforzate con cuscinetti a rulli conici sulla corona in grado di sopportare carichi superiori rispetto a quelli ammessi nelle versioni normali con cuscinetti radiali a sfere. Essendo tali valori calcolati in funzione della durata dei cuscinetti, occorre valutare attentamente il tipo di versione più idoneo in modo da evitare problemi di tipo strutturale. In particolare, il carico assiale deve agire in modo da comprimere la flangia uscita.

**I carichi assiali e radiali riportati in tabella non possono agire contemporaneamente nei loro valori massimi.**

Nel caso di eventuale concorrenza delle due forze, queste devono essere limitate in rapporto al tipo di carico prevalente:

#### 1. condizione di prevalenza del carico radiale:

$$Fr_2 = \text{come a tabella}$$

$$Fa_2 = Fr_2 \cdot 0.37$$

#### 2. condizione di prevalenza del carico assiale:

$$Fa_2' = Fa_2 \cdot 0.6$$

$$Fr_2' = Fa_2 \cdot 0.4$$

### Reinforced versions

*The versions reinforced with tapered roller bearings on the worm wheel are available on request. They can bear higher loads compared to standard versions with radial ball bearings. These values are calculated in relation of the life of bearings therefore it is necessary to select the most suitable version in order to avoid any structural problem. In particular the axial load must compress the output flange.*

**The axial and radial loads shown in the table do not have to act simultaneously according to the max. values.**

*In case of concurrency of both forces these have to be reduced with regard to the prevailing type of load:*

#### 1. prevalence of radial load:

$$Fr_2 = \text{as per table}$$

$$Fa_2 = Fr_2 \cdot 0.37$$

#### 2. prevalence of axial load:

$$Fa_2' = Fa_2 \cdot 0.6$$

$$Fr_2' = Fa_2 \cdot 0.4$$

### Усиленные версии

По запросу предлагаются усиленные версии с коническими роликовыми подшипниками на выходном валу, которые могут выдерживать более высокие нагрузки, чем допустимые в обычных версиях с радиальными шарикоподшипниками. Поскольку эти значения рассчитываются в зависимости от срока службы подшипников, следует внимательно выбрать наиболее подходящий тип исполнения во избежание конструктивных проблем. В частности, осевая нагрузка должна действовать так, чтобы сжимать выходной фланец.

**Осевые нагрузки, приведённые в таблице, не могут действовать одновременно с максимальными значениями.**

В случае одновременного воздействия двух сил, необходимо ограничить их в зависимости от типа доминирующей нагрузки:

#### 1. преимущественная радиальная нагрузка:

$$Fr_2 = \text{как в таблице}$$

$$Fa_2 = Fr_2 \cdot 0.37$$

#### 2. преимущественная осевая нагрузка:

$$Fa_2' = Fa_2 \cdot 0.6$$

$$Fr_2' = Fa_2 \cdot 0.4$$

CUSCINETTI A RULLI CONICI / TAPERED ROLLER BEARINGS / ПОДШИПНИКИ С КОНИЧЕСКИМИ РОЛИКАМИ																			
$n_1=1400$ ОБ/МИН		30		40		50		63		75		89		90		110		130	
$i_n$	$n_2$ [ОБ/МИН]	a=61.4	b=43.9	a=77	b=54	a=94.5	b=66	a=114.8	b=85.8	a=123.8	b=89.8	a=152.8	b=107.8	a=152.8	b=107.8	a=167.3	b=119.3	a=174.8	b=129.8
		$Fr_2$	$Fa_2$	$Fr_2$	$Fa_2$	$Fr_2$	$Fa_2$	$Fr_2$	$Fa_2$	$Fr_2$	$Fa_2$	$Fr_2$	$Fa_2$	$Fr_2$	$Fa_2$	$Fr_2$	$Fa_2$	$Fr_2$	$Fa_2$
5	280	800	1100	1800	2300	4000	5000	4000	5000	/	/	/	/	/	/	/	/	/	/
7.5	187	900	1200	1900	2400	4500	5500	4500	5500	5300	6500	6000	8000	6000	8000	8000	10500	9500	11000
10	140	1000	1300	2000	2500	5000	6000	5000	6000	5500	6700	7000	9200	7000	9200	8300	11000	10500	12500
15	93	1100	1400	2100	2600	5800	7000	5800	7000	5700	6900	7400	9800	7400	9800	8800	11500	11000	13000
20	70	1250	1650	2300	2800	6000	7200	6100	7300	6400	7600	7800	10300	7800	10300	9300	12000	15000	13500
25	56	1450	1900	2500	3000	6200	7500	6500	7700	7400	9400	8500	11000	8500	11000	9800	12500	12000	14000
30	47	1700	2200	2800	3300	6500	7800	6800	8000	8000	10000	9500	12000	9500	12000	10500	13200	12500	14000
40	35	1800	2300	3000	3500	6600	8000	7000	8200	8500	10500	10000	12500	10000	12500	11000	14000	14000	16000
50	28	1900	2400	3200	3700	6800	8200	7100	8400	9000	11000	10500	13000	10500	13000	12000	15000	14500	17000
60	23	1900	2400	3200	3700	6800	8200	7100	8400	9000	11000	10500	13000	10500	13000	12000	15000	15000	17000
63	22	1900	2400	3200	3700	6800	8200	7100	8400	9000	11000	10500	13000	10500	13000	12000	15000	15000	17000
80	17.5	1900	2400	3200	3700	6800	8200	7100	8400	9000	11000	10500	13000	10500	13000	12000	15000	15000	17000
100	14	1900	2400	3200	3700	6800	8200	7100	8400	9000	11000	10500	13000	10500	13000	12000	15000	15000	17000
120	11.7	1900	2400	3200	3700	6800	8200	7100	8400	9000	11000	10500	13000	10500	13000	12000	15000	15000	17000
150	9.3	1900	2400	3200	3700	6800	8200	7100	8400	9000	11000	10500	13000	10500	13000	12000	15000	15000	17000
160	8.8	1900	2400	3200	3700	6800	8200	7100	8400	9000	11000	10500	13000	10500	13000	12000	15000	15000	17000
$\geq 200 \leq 7.0$		1900	2400	3200	3700	6800	8200	7100	8400	9000	11000	10500	13000	10500	13000	12000	15000	15000	17000
Cuscinetto Bearing Подшипник		32005 25x47x15		32006 30x55x17		32008 40x68x19		32008 40x68x19		32010 50x80x20		32010 50x80x20		32010 50x80x20		32012 60x95x23		32015 75x115x25	

### 1.11 Potenza termica

Nelle tabelle riportate nelle sezioni relative ad ogni tipologia di riduttore sono indicati i valori della potenza termica nominale  $P_{t0}$  [kW]. Tale valore rappresenta la potenza massima applicabile all'entrata del riduttore, in servizio continuo a temperatura massima ambiente di 30°C, così che la temperatura dell'olio non oltrepassi il valore di 95°C.

**Il valore di  $P_{t0}$  non deve essere preso in considerazione** se il funzionamento è continuo per un massimo di 1 - 2 ore seguito da pause di durata sufficiente (circa 2 ore) a ristabilire nel riduttore la temperatura ambiente.

I valori di  $P_{t0}$  devono essere corretti tramite i seguenti coefficienti, così da considerare le reali condizioni di funzionamento, ottenendo i valori di potenza termica corretta  $P_{tc}$ .

### 1.11 Thermal power

*The sections dedicated to each type of gearbox contain tables reporting the values of  $P_{t0}$  rated thermal power (kW). Listed values represent the max. power applicable at gearbox input, on continuous duty and at an ambient temperature of max. 30°C, so that oil temperature does not exceed 95°C.*

**$P_{t0}$  value is not to be taken into account** if duty is continuous for max. 1 - 2 hours and followed by breaks which are long enough to bring the gearbox back to ambient temperature (roughly 2 hours). In order to take the actual operating conditions into account,  $P_{t0}$  values have to be corrected with the following coefficients, thus obtaining the values of  $P_{tc}$  corrected thermal power.

### 1.11 Тепловая мощность

В таблицах, приведённых в разделах для каждого типа редуктора, указаны значения номинальной тепловой мощности  $P_{t0}$  [кВт]. Это значение представляет собой максимальную мощность, применимую на входе редуктора в условиях непрерывной работы при максимальной температуре окружающей среды 30°C, чтобы температура масла не превышала значение 95°C.

**Значение  $P_{t0}$  не должно приниматься во внимание**, если работа продолжается не более 1 - 2 часов с последующими паузами достаточной продолжительности (около 2 часов) для восстановления температуры окружающей среды в редукторе.

Значения  $P_{t0}$  должны быть скорректированы с помощью следующих коэффициентов, чтобы учитывать реальные рабочие условия, получая откорректированные значения тепловой мощности  $P_{tc}$ .

$$P_{tc} = P_{t0} \cdot ft \cdot fv \cdot fu \text{ [kW]}$$

I coefficienti di correzione sono ricavabili dalle seguenti tabelle:

Dove:

- ft = coefficiente di temperatura ambiente
- fv = coefficiente di ventilazione
- fu = coefficiente di utilizzo

*Corrective coefficients are shown in the following tables:*

Where:

- ft = environment temperature coefficient
- fv = ventilation coefficient
- fu = utilization coefficient

Корректирующие коэффициенты получаются из следующих таблиц:

Где:

- ft = коэффициент температуры окружающей среды
- fv = коэффициент вентиляции
- fu = коэффициент эксплуатации

Ta (°C)	0	5	10	15	20	25	30	35	40	45	50
ft	1.46	1.38	1.31	1.23	1.15	1.1	1.0	0.92	0.85	0.77	0.69

Ta = Temperatura ambiente (°C)

Ta = ambient temperature (°C)

Ta = Температура окружающей среды (°C)

fv = 1.45 con ventilazione forzata efficace con ventola dedicata

fv = 1.45 for forced ventilation with specific fan

fv = 1.45 с эффективной принудительной вентиляцией со специальным вентилятором

fv = 1.25 con ventilazione forzata secondaria ad altri dispositivi (pulegge, ventole, motore, ecc.)

fv = 1.25 for forced ventilation secondary to other devices (pulleys, fans, motor, etc.)

fv = 1.25 со вторичной принудительной вентиляцией на другие устройства (шкивы, импеллеры, двигатель и т.д.)

**fv = 1 refrigerazione naturale (situazione standard)**

**fv = 1 for natural cooling (standard situation)**

**fv = 1 естественное охлаждение (стандартная ситуация)**

fv = 0.5 in ambiente chiuso e ristretto (carter)

fv = 0.5 in a close and narrow environment (case)

fv = 0.5 в закрытом и ограниченном помещении (картер)

Dt (min)	10	20	30	40	50	60
fu	1.6	1.35	1.2	1.1	1.05	1

Dt = minuti di funzionamento in un'ora

Dt = minutes of operation per hour

Dt = минуты работы в час 1.12

### 1.12 Selezione

#### Scelta del riduttore

**A)  $n_1 = 1400, 2800, 900, 500 \text{ min}^{-1}$**

Si sceglierà nelle tabelle delle prestazioni dei riduttori un gruppo che in corrispondenza di un rapporto prossimo a quello calcolato ammetta una potenza:

### 1.12 Selection

#### Selecting a gearbox

**A)  $n_1 = 1400, 2800, 900, 500 \text{ min}^{-1}$**

Consult the gearbox unit efficiency table; select a group whose ratio is close to the calculated ratio and which permits power:

### 1.12 Выбор

#### Выбор редуктора

**A)  $n_1 = 1400, 2800, 900, 500 \text{ мин}^{-1}$**

В таблицах характеристик редукторов следует выбрать группу, которая при передаточном числе, близком к рассчитанному, допускает мощность:

$$P \geq P' \cdot FS'$$

## Scelta del motoriduttore

### B) FS =1

Si cercherà nelle tabelle delle prestazioni dei motoriduttori un gruppo la cui potenza  $P_1$  corrisponda alla  $P'$  calcolata.

### C) FS ≠1

La scelta dovrà essere effettuata come al punto A) verificando che la grandezza del motore da installare sia compatibile con quelle ammesse dal riduttore (IEC); ovviamente la potenza installata dovrà corrispondere al valore  $P'$  richiesto.

Determinato il riduttore idoneo è necessario verificare che anche gli eventuali carichi aggiuntivi (radiali ed assiali) agenti sugli alberi in uscita e/o entrata rientrino nei valori ammissibili dati a catalogo.

In determinate condizioni applicative può diventare necessario verificare che la potenza assorbita dal riduttore non superi quella del limite termico riportata a catalogo, secondo quanto riportato al punto 1.10 relativamente alla potenza termica.

## 1.13 Lubrificazione

Tutti i riduttori, eccetto X130 e K130, sono forniti completi di lubrificante sintetico a base PAG con indice di viscosità ISO VG320.

I cuscinetti dell'albero veloce vengono sempre lubrificati con grasso a base sintetica per tutte le posizioni di montaggio, solamente per le posizioni di montaggio B6 - B7, per una corretta lubrificazione, vengono ingrassati anche i cuscinetti dell'albero lento. Questo significa che solamente dalle posizioni di montaggio B6 - B7 si può passare a tutte le altre posizioni, modificando esclusivamente le quantità di olio, come indicato nelle relative tabelle; per quanto riguarda invece le posizioni di montaggio B3 - B8 - V5 - V6, possono essere intercambiabili solo tra di loro, senza modificare la quantità di olio.

**Attenzione!** per i riduttori a vite senza fine con precoppia HA - HF, la posizione di montaggio V5 non può essere intercambiabile con nessun'altra posizione; per quanto riguarda l'ingrassaggio dei cuscinetti dei riduttori combinati, la posizione di montaggio deve essere riferita al singolo riduttore.

Una scelta oculata del tipo di lubrificante, in funzione delle condizioni operative e ambientali, consente ai riduttori di raggiungere le prestazioni ottimali.

Le prestazioni dei riduttori indicate nelle tabelle dei dati tecnici sono state calcolate considerando l'impiego di olio sintetico.

### VISCOSITA'

È uno dei parametri più importanti da considerare nella scelta di un olio ed è influenzabile da diversi parametri quali velocità, temperatura. Riportiamo sinteticamente le valutazioni generali per la scelta della giusta viscosità:

## Selecting a gearmotor

### B) FS =1

Consult the gear motor efficiency table and select a group having power  $P_1$  corresponding to calculated  $P'$ .

### C) FS ≠1

Follow the instructions at point A), checking that the size of the motor to be installed is compatible with the gearbox unit (IEC); obviously, installed power must correspond to the required  $P'$  value.

After having selected the proper gearbox, it is necessary to check out that possible additional loads (radial or axial) on the input and /or output shafts fall within the values reported in the catalogue.

Depending on the application, it might be necessary to check that the power absorbed by the gearbox does not exceed the thermal power limit reported in the catalogue as per paragraph 1.10.

## 1.13 Lubrification

All worm gearboxes, except for the type X130 and K130, are supplied with synthetic lubricant, PAG base, viscosity index ISO VG 320.

The bearings mounted on the input shaft are always supplied with synthetic -base grease for all mounting positions. For mounting positions B6 - B7, the output shaft bearings are also greased to ensure correct lubrication. This means that it is possible to switch from the mounting positions B6 - B7 to all the other positions, changing only the quantities of oil specified in the corresponding tables. Mounting positions B3 - B8 - V5 - V6 can be exchanged without changing the oil quantity.

**Caution!** for worm gearboxes with HA - HF pre-stage, the V5 mounting position cannot be interchangeable with any other position; as regards the greasing of the bearings of the combined gearboxes, the mounting position must refer to the single reducer.

Choose the lubricant according to operating and ambient conditions in order to ensure high gear unit performance.

Performance data, as shown in the specifications tables, refer to utilization of synthetic oil.

### VISCOSITY

It is one of the most important parameters to be considered when selecting an oil; it depends on various factors such as speed and temperature. Following are general guidelines for choosing the correct viscosity:

## Выбор мотор-редуктора

### B) FS =1

В таблицах характеристик мотор-редукторов следует найти группу, мощность которой  $P_1$  будет соответствовать рассчитанной  $P'$ .

### C) FS ≠1

Выбор должен быть сделан, как в пункте A), убеждаясь, что типоразмер устанавливаемого двигателя совместим с допустимым типоразмером редуктора (МЭК); безусловно, установленная мощность должна соответствовать требуемому значению  $P'$ .

Как только подходящий редуктор будет определен, необходимо проверить, что любые дополнительные нагрузки (радиальные и осевые), действующие на выходной и / или входной валы, находятся в пределах допустимых значений, указанных в каталоге.

При определенных условиях применения может возникнуть необходимость проверки того, что мощность, поглощаемая редуктором, не превышает тепловое ограничение, указанное в каталоге, в соответствии со значением тепловой мощности, указанным в пункте 1.10.

## 1.13 Смазывание

Все редукторы, за исключением X130 и K130, укомплектованы синтетической смазкой на основе PAG (полиалкиленгликоль) с индексом вязкости ISO VG320.

Подшипники быстрого вала всегда смазываются синтетической смазкой для всех монтажных положений, только для монтажных положений B6 - B7 для надлежащей смазки также смазываются подшипники медленного вала. Это означает, что, как правило, с монтажных позиций B6 - B7 можно перейти на все остальные позиции, изменяя только количество масла, как указано в соответствующих таблицах. Что касается монтажных положений B3 - B8 - V5 - V6, они могут быть взаимозаменяемыми только между собой, без изменения количества масла.

**Внимание!** Для червячных редукторов с предварительной ступенью HA - HF монтажное положение V5 не может быть взаимозаменяемо с любым другим положением; что касается смазки подшипников комбинированных редукторов, монтажная позиция должна относиться к одному редуктору. Тщательный выбор типа смазки, в соответствии с условиями эксплуатации и окружающей среды, позволяет редукторам достичь оптимальной производительности.

Указанные эксплуатационные качества редукторов в таблицах технических данных были рассчитаны с учётом использования синтетического масла.

### ВЯЗКОСТЬ

Это один из наиболее важных параметров, учитываемых при выборе масла, и на него могут влиять различные параметры, такие как скорость и температура. Далее вкратце приводится общая информация для выбора правильной вязкости:

### Viscosità alta

Usare per basse velocità di rotazione e/o temperature alte.

(Una viscosità troppo bassa in queste condizioni operative causa una usura precoce).

### Viscosità bassa

Usare per alte velocità di rotazione e/o temperature basse.

(Una viscosità troppo elevata provoca diminuzione del rendimento e surriscaldamento).

### ADDITIVI

In tutti gli oli minerali sono contenuti degli additivi antiusura, EP (più o meno energici), antiossidanti ed antischiuma. È opportuno assicurarsi che essi siano blandi e non aggressivi nei confronti delle garnizioni.

### BASE DELL'OLIO

Può essere minerale o sintetica.

L'olio sintetico, compensa il costo più elevato con una serie di vantaggi:

- a) minor coefficiente d'attrito (quindi migliore rendimento)
- b) migliore stabilità nel tempo (possibile lubrificazione a vita)
- c) migliore indice di viscosità (migliore la adattabilità alle varie temperature).

L'olio a base minerale come vantaggi ha il minore costo e un migliore comportamento in rodaggio.

### High viscosity

To be used for low rotation speed and/or high temperatures.

(Under these operating conditions a low viscosity causes premature wear).

### Low viscosity

To be used for high rotation speed and/or low temperatures.

(High viscosity reduces efficiency and causes overheating).

### ADDITIVES

All mineral oils contain additives to protect against wear, EP (more or less strong), anti-oxidizing and anti-frothing. It is advisable to make sure that the action of such additives is bland and not too aggressive on the seals.

### OIL BASE

May be mineral or synthetic.

Synthetic oil compensates for the higher cost with a series of advantages:

- a) lower friction coefficient (consequently improved efficiency)
- b) better stability over time (possible life lubrication)
- c) better viscosity index (more adaptable to various temperatures).

Mineral-base oils offer the advantages of costing less and performing better during the running-in period.

### Высокая вязкость

Использовать для низкой скорости вращения/или высокой температуры.

(Слишком низкая вязкость в этих рабочих условиях приводит к преждевременному износу).

### Низкая вязкость

Использовать для высокой скорости вращения/или низкой температуры.

(Слишком высокая вязкость приводит к сокращению КПД и перегреву).

### ДОБАВКИ

Во всех минеральных маслах содержатся добавки, устойчивые к износу EP (противозадирные присадки) (более или менее энергичные), антиокислители и пеногасители. Следует убедиться, что они не оказывают агрессивного воздействия на уплотнители.















### МАСЛЯННАЯ ОСНОВА

Масло может быть минеральным или синтетическим.

Синтетическое масло компенсирует более высокие затраты рядом преимуществ:

- a) меньший коэффициент трения (следовательно, более высокая эффективность)
- b) лучшая стабильность во времени (возможна вечная смазка)
- c) лучшей индекс вязкости (лучшая приспособляемость к различным температурам).

Минеральное масло как преимущество имеет меньшую цену и лучшую обкатку.

ISO VG		OLIO MINERALE / MINERAL OIL / МИНЕРАЛЬНОЕ МАСЛО			OLIO SINTETICO / SYNTHETIC OIL / СИНТЕТИЧЕСКОЕ МАСЛО					
		460	320	220	460	320	220	150		
Temperatura ambiente Amb. Temp. Ta (°C) Температура окружающей среды		5° ÷ 45°	0° ÷ 40°	-5° ÷ 35°	-15° ÷ 100°	-20° ÷ 90°	-25° ÷ 80°	-30° ÷ 70°		
FORNITORE / MANUFACTURER / ПОСТАВЩИК		<b>MINERALE / MINERAL / МИНЕРАЛЬНОЕ</b>								
		SHELL		Omala OIL 460	Omala OIL 320	Omala OIL 220				
		BP		Energol GRXP 460	Energol GRXP 320	Energol GRXP 220				
		TEXACO		Meropa 460	Meropa 320	Meropa 220				
		CASTROL		Alpha SP 460	Alpha SP 320	Alpha SP 220				
		KLUBER		Lamora 460	Lamora 320	Lamora 220				
		MOBIL		Mobilgear 634	Mobilgear 632	Mobilgear 630				
		<b>Tecnologia PAG (polialcoliglicoli) / PAG Technology (polyalkyleneglycol) / Технология PAG (полиалкиленгликоль)</b>								
		SHELL					Omala S4 WE 460	Omala S4 WE 320	Omala S4 WE 220	Omala S4 WE 150
		BP					Energol SGXP460	Energol SGXP320	Energol SGXP220	Enersyn SG 150
		TEXACO					Synlube CLP 460	Synlube CLP 320	Synlube CLP 220	
		AGIP						Agip Blasias S 320	Agip Blasias S 220	Agip Blasias S 150
		<b>Tecnologia PAO (polialcoliolifini) / PAO Technology (polialphaolefin) / Технология PAO (полиальфаолефины)</b>								
		SHELL					Omala OIL RL/HD 460	Omala OIL RL/HD 320	Omala OIL RL/HD 220	Omala OIL RL/HD 150
		CASTROL					Alpha Synt 460	Alpha Synt 320	Alpha Synt 220	Alpha Synt 150
		KLUBER					Synteso D460 EP	Synteso D320 EP	Synteso D220 EP	Synteso D150 EP
		MOBIL					SHC 634	SHC 632	SHC 630	SHC 629



### 1.14 Installazione

Fissare il riduttore in modo tale da evitare qualsiasi vibrazione e curare l'allineamento del riduttore con il motore e l'utenza utilizzando, quando è possibile, giunti di accoppiamento.

Assicurarsi che gli organi da montare sui riduttori abbiano le tolleranze ISO h6 per gli alberi e ISO H7 per i fori.

Se il riduttore viene installato all'aperto si consiglia l'utilizzo del tappo di sfiato con valvola, tranne le grandezze 30-40-50-63-75-89.

Tutti i riduttori e motoriduttori citati nel presente manuale sono destinati ad un impiego industriale con temperatura ambiente da -20°C a +40°C ad una altitudine max di 1000 m slm.

Per tutte le altre avvertenze consultare il manuale di "uso e manutenzione" scaricabile dal sito [www.tramec.it](http://www.tramec.it)

### 1.15 Manutenzione

Tutti i riduttori a vite senza fine, eccetto X130, sono lubrificati a vita con olio sintetico tipo SHELL OMALA S4 WE 320.

Non necessitano quindi di particolari manutenzioni se non il mantenimento della pulizia esterna, evitando l'uso di solventi per non danneggiare guarnizioni o anelli di tenuta, ed il rispetto di tutte le indicazioni e della eventuale sostituzione dell'olio negli intervalli programmati e riportati nel manuale di "uso e manutenzione" scaricabile dal sito [www.tramec.it](http://www.tramec.it)

### 1.16 Verniciatura

Le carcasse in ghisa e le flange delle grandezze 90, 110 e 130 sono verniciate di colore BLU RAL 5010 mentre quelle in alluminio delle grandezze 89, 75, 63, 50, 40 e 30 sono sabbiate.

### 1.14 Installation

*The gearbox has to be mounted to prevent any vibration. Check carefully the alignment gearbox / motor / machine and use couplings whenever possible. Check that devices to be mounted on the gearbox feature ISO h6 tolerance for the shafts and ISO H7 for the holes.*

*If the gearbox is installed outdoors, we recommend the use of the breather plug with valve, except size 30-40-50-63-75-89.*

*All reducers and gear motors mentioned in this catalog are intended for industrial use and operation at a ambient temperature between -20°C and +40°C, at an altitude of max. 1000 m above sea level.*

*For all other instructions check the "Use and Maintenance Manual" which can be downloaded from our web site [www.tramec.it](http://www.tramec.it)*

### 1.15 Maintenance

*All worm gearboxes, except for the type X130, are lubricated for life with synthetic oil SHELL OMALA S4 WE 320.*

*For this reason they do not require any particular maintenance, except for external cleaning (avoid the use of solvents which might damage gaskets and oil seals) and observance of the schedules for oil change as reported in the "Use and Maintenance Manual" which can be downloaded from our web site [www.tramec.it](http://www.tramec.it)*

### 1.16 Painting

*Size 90, 110 and 130 have cast iron housings and flanges painted BLUE RAL 5010.*

*The housings of sizes 89, 75, 63, 50, 40 and 30 are made in aluminium and sandblasted.*

### 1.14 Установка

Закрепите редуктор таким образом, чтобы избежать вибрации и выровнять редуктор с двигателем и используемой системой, используя, по возможности, соединительные муфты.

Проверить, что органы, устанавливаемые на редукторы, имеют допуски ISO h6 для валов и ISO H7 для отверстий.

Если редуктор устанавливается на открытом воздухе, рекомендуется использовать пружинный сапун, кроме типоразмеров 30-40-50-63-75-89.

Все редукторы и мотор-редукторы, приведённые в настоящем руководстве, предназначены для промышленного использования при температуре окружающей среды от -20 ° C до + 40 ° C на максимальной высоте 1000 м над уровнем моря.

Все другие предупреждения приводятся в руководстве по "эксплуатации и техобслуживанию", который можно скачать на сайте [www.tramec.it](http://www.tramec.it)

### 1.15 Техобслуживание

Все червячные редуктора, за исключением X130, имеют смазку на весь срок службы, реализованную с синтетическом маслом типа SHELL OMALA S4 WE 320.

Не нуждаются в особых операциях техобслуживания кроме внешней очистки, при этом нельзя использовать растворители, чтобы не повредить уплотнительные кольца, и необходимо соблюдать все указания по замене масла через указанные интервалы, приведённые в руководстве по "эксплуатации и техобслуживанию", который можно скачать на сайте [www.tramec.it](http://www.tramec.it)

### 1.16 Окраска

Чугунные корпус и фланцы типоразмеров 90, 110 и 130 окрашены в синий цвет RAL 5010, а алюминиевые корпус и фланцы типоразмеров 89, 75, 63, 50, 40 и 30 прошли пескоструйную обработку.

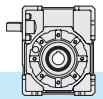

2.0	RIDUTTORI A VITE SENZA FINE X	X WORM GEARBOXES	ЧЕРВЯЧНЫЕ РЕДУКТОРЫ X
2.1	Caratteristiche	<i>Characteristics</i>	Характеристики 16
2.2	Designazione	<i>Designation</i>	Назначение 17
2.3	Lubrificazione e posizioni di montaggio	<i>Lubrication and mounting position</i>	Смазка и рабочие положения в пространстве 18
2.4	Posizione morsettiera	<i>Terminal board position</i>	Позиция клеммной коробки 18
2.5	Dati tecnici	<i>Technical data</i>	Технические данные 19
2.6	Momenti d'inerzia	<i>Moment of inertia</i>	Моменты инерции 27
2.7	Dimensioni	<i>Dimensions</i>	Габаритные размеры 32
2.8	Entrata supplementare	<i>Additional input</i>	Дополнительный вход 37
2.9	Limitatore di coppia cavo passante	<i>Torque limiter with through hollow shaft</i>	Ограничитель момента вращения с полым сквозным валом 37
2.10	Accessori	<i>Accessories</i>	Комплектующие 39
2.11	Lista parti di ricambio	<i>Spare parts list</i>	Перечень запчастей 40

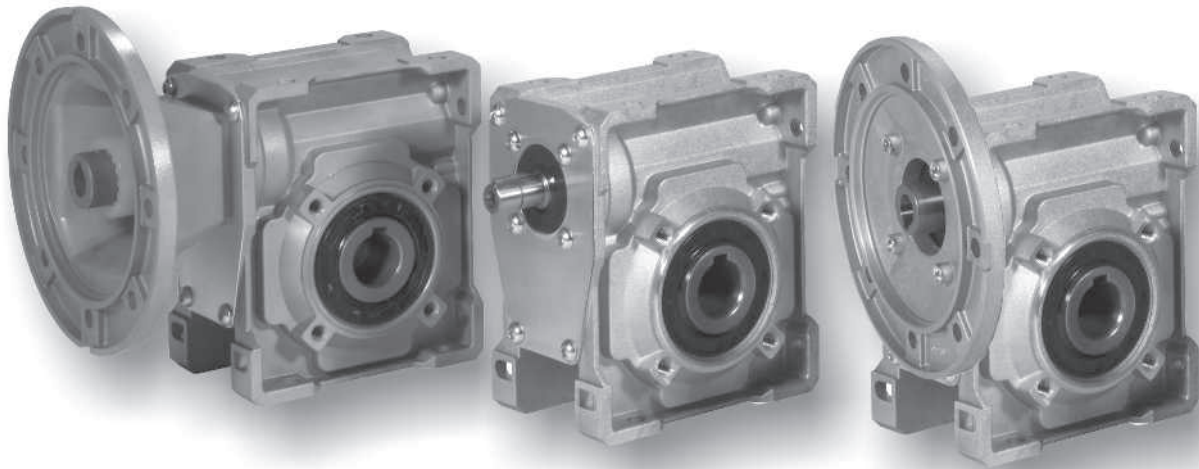

**XF**

**XA**

**XC**

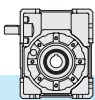

## 2.1 Caratteristiche

- I riduttori a vite senza fine della serie X sono disponibili nelle versioni alberata XA e con predisposizione per attacco motore XF-XC. La grandezza 89 è disponibile solo nella versione XC.
- La versione XF (campana + giunto), caratterizzata da una più ampia versatilità ai diversi tipi di applicazioni, presenta un più elevato rendimento rispetto a quello della serie compatta XC la quale, a sua volta, presenta il vantaggio di un ingombro più ridotto.
- La carcassa monoblocco è in ghisa nelle grandezze 90, 110 e 130, in alluminio pressofuso per le grandezze 30, 40, 50, 63, 75 e 89.
- La vite senza fine è in acciaio legato cementato-temprato ed è rettificata.
- La corona ha il mozzo in ghisa con riporto di fusione dell'anello in bronzo.
- Le carcasse in ghisa sono verniciate BLU RAL5010 mentre quelle in alluminio sono sabbiate.
- Viene fornito l'albero uscita cavo di serie ed esiste un'ampia disponibilità di accessori: seconda entrata, cuscinetti conici sulla corona, flangia uscita, albero lento con 1 o 2 sporgenze, limitatore di coppia con cavo passante, braccio di reazione, kit protezione albero cavo, kit protezione limitatore di coppia.

## 2.1 Characteristics

- *X series worm gearboxes are available in the following versions : XA with shaft, XF and XC suitable for motor mounting assembling. The size 89 is only available in the XC version.*
- *The XF version (bell + joint) suits a wider range of applications and provides higher efficiency than the XC compact version, which actually offers reduced space requirement.*
- *The enbloc housing is in cast-iron for sizes 90, 110 and 130, in die-cast aluminium for sizes 30, 40, 50, 63, 75 and 89.*
- *The worm shaft is in case-and quench-hardened alloy steel and ground.*
- *The worm wheel has a cast-iron hub provided with inserted cast-bronze ring.*
- *The housings in cast iron are painted BLUE RAL 5010, those in aluminium are sandblasted.*
- *The hollow output shaft is supplied as standard. A broad range of accessories is available: second input, tapered roller bearings on the worm wheel, output flange, single or double-extended output shaft, torque limiter with through hollow shaft, torque arm, hollow shaft protection kit, torque limiter protection kit.*

## 2.1 Характеристики



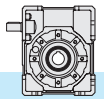



- Червячные редукторы серии X выпускаются в версиях с валом XA и для прямого подключения на двигатель XF-XC. Типоразмер 89 в наличии только для версии XC.
- Версия XF (стакан + муфта), более универсальная и подходит для разных типов применения, имеет более высокий КПД по отношению к компактной серии XC, которая, в свою очередь, отличается уменьшенными габаритными размерами.
- Типоразмеры 90, 110 и 130 имеют монолитный чугунный корпус, а типоразмеры 30, 40, 50, 63, 75 и 89 имеют корпус из алюминия, отлитого под давлением.
- Червячный вал из закалённого цементированного стального сплава, шлифованный.
- Червячный венец имеет чугунную ступицу с бронзовым кольцом, нанесенным литьевым способом.
- Чугунные корпуса окрашены в цвет СИНИЙ RAL5010, а алюминиевые прошли пескоструйную обработку.
- В стандартную комплектацию входит полый выходной вал, а также есть широкая гамма комплектующих: второй входной вал, конические подшипники на выходном валу, выходной фланец, цельный тихоходный вал, односторонний или двухсторонний, ограничитель крутящего момента с полым сквозным валом, моментный рычаг, защитный комплект полого вала, защитный комплект ограничителя крутящего момента.

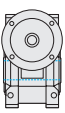
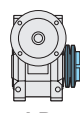
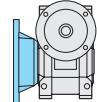
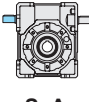

2.2 Designazione

2.2 Designation

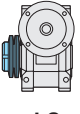
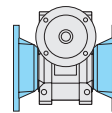
2.2 Назначение

RIDUTTORE / GEARBOX / РЕДУКТОРЫ											
Riduttore Gearbox Редуктор	Tipo entrata Input type Тип входа	Grandezza Size Типоразмер	Rapporto rid. Ratio Перед. число	Predispos. at. mot. Motor coupling Возм. подкл. двиг.	Albero uscita cavo Hollow output shaft Выходной полый вал	Limitatore di coppia. Torque limiter Ограничитель момента вращения.	Flangia in uscita. Output flange Выходной фланец.	Seconda entrata Additional input второй входной вал	Posizione di mont. Mounting position Положение в пространстве		
X	A	50	10/1	P.A.M	H25	LD	F1S	SeA	B3		
Riduttore a vite senza fine Wormgearbox Червячный редуктор	 A	30 40 50 63 75 89*	5 7.5 10 15 20 25 30 40 50 65 80 100	56 63 71 80 90 100 112 132	vedi tabelle  see tables  см. таблицы  	 LD	 F1S-F2S-F3S	 SeA	B3, B6 B7, B8 V5, V6		
	 C	 Alluminio Aluminium Алюминий	90 110 130	 Ghisa Cast iron Чугун						 LS	 F12-F22-F32
	 F										

\*: 89 solo con tipo di entrata C

\*: 89 only with input type C

\*: 89 только с типом входа C

Tipo entrata

Input type

Тип входа

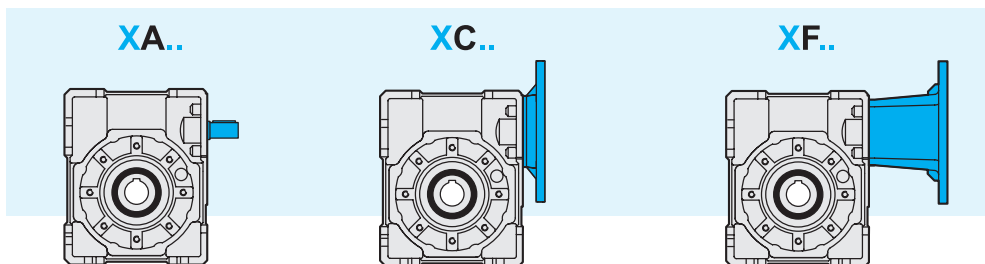



### 2.3 Lubrificazione

I riduttori a vite senza fine serie X, tranne la grandezza 130, sono forniti completi di lubrificante sintetico a base PAG con indice di viscosità ISO VG320. Si raccomanda di precisare sempre, in fase di ordine, la posizione di lavoro considerata.

Per ulteriori dettagli consultare pag. 12 paragrafo 1.13.

### 2.3 Lubrication

X series worm gearboxes, except for the size 130, are supplied with synthetic lubricant, PAG base, viscosity index ISO VG320. Mounting position always to be specified when ordering.

For more details, see page 12, paragraph 1.13.

### 2.3 Смазывание

Червячные редукторы серии X, кроме типоразмера 130, укомплектованы синтетической смазкой на основе PAG с индексом вязкости ISO VG320. Рекомендуется всегда указывать при заказе требуемую рабочую позицию.

Дополнительная информация приводится на стр. 12 в параграфе 1.13.

### Posizioni di montaggio

### Mounting positions

### Положение в пространстве

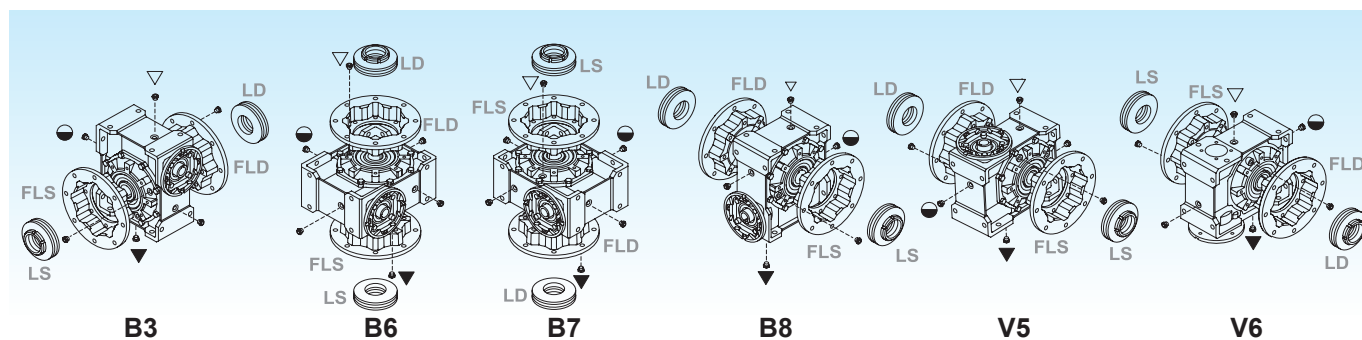

- ▽ Carico e sfiato / Filling and breather  
Заполнение и стравливание
- Livello / Level / Уровень
- ▼ Scarico / Drain / Слив

Nei corpi in alluminio 30, 40, 50, 63, 75 e 89 è presente un solo tappo di riempimento olio.

30, 40, 50, 63, 75 and 89 aluminium housings have one oil filling plug only.

На алюминиевых корпусах 30, 40, 50, 63, 75 и 89 имеется только одна заливная крышка масла.

		Q.tà olio / Oil quantity / К-во масла [lt]			
		Posizione di montaggio / Mounting position / Позиция сборки			
		B3	B6 - B7	B8	V5 - V6
<b>X</b>	<b>30</b>	0.015	0.030	0.015	
	<b>40</b>	0.040	0.060	0.040	
	<b>50</b>	0.080	0.120	0.080	
	<b>63</b>	0.160	0.220	0.160	
	<b>75</b>	0.260	0.340	0.260	
	<b>89</b>	0.450	0.750	0.450	
	<b>90</b>	1.1	0.9	1	1.5
	<b>110</b>	2.2	1.8	1.6	2.6
<b>130</b>	3.6	3	2.5	3.8	

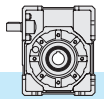

2.4 Posizione morsettiera

2.4 Terminal board position

2.4 Позиция клеммной коробки

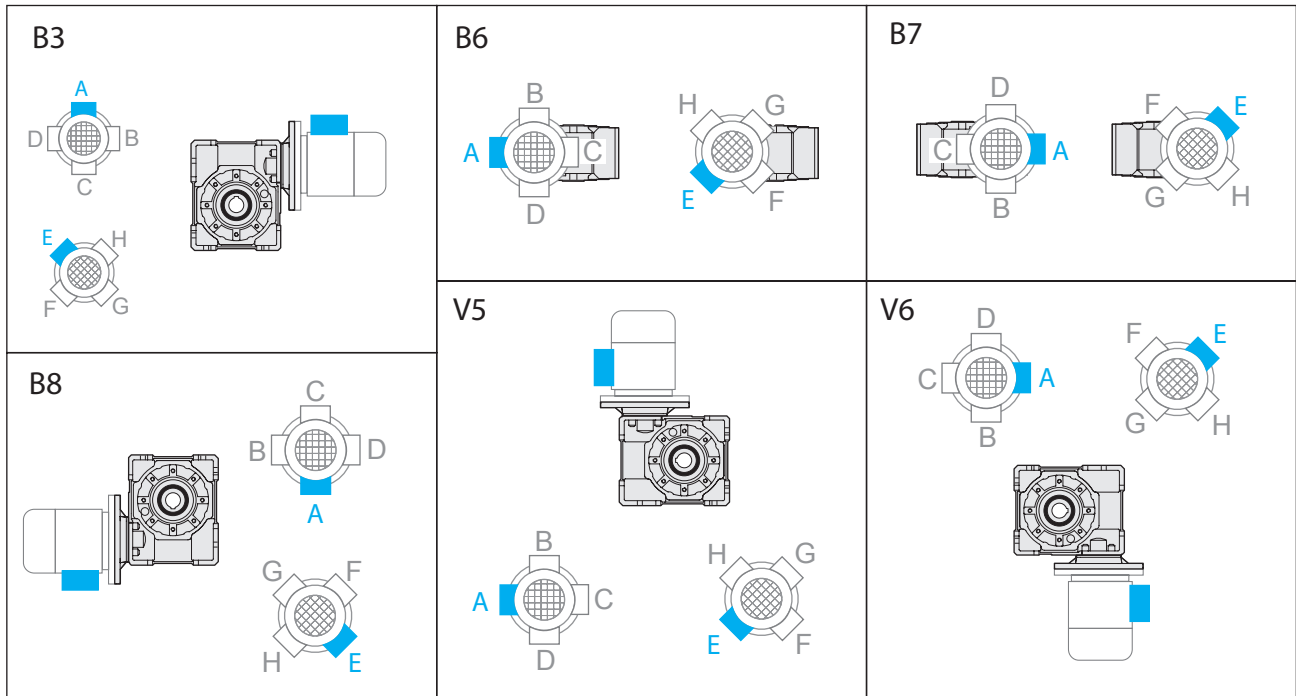

Specificare sempre in fase di ordinazione la posizione di montaggio e la forma costruttiva.  
 Posizione morsettiera v. pag. 35-36 (PM=1; PM=2)

*Mounting position always to be specified when ordering.*  
 Terminal board position see page 35-36 (PM=1; PM=2)

Всегда указывает при составлении заказа позицию сборки и форму конструкции.  
 Позиция клеммной коробки см. стр. 35-36 (PM=1; PM=2)



2.5 Dati tecnici

2.5 Technical data

2.5 Технические данные

30	$n_1 = 2800$				XA		XC - XF								
	$i_n$	$n_2$ [min <sup>-1</sup> ]	Rd	$P_{10}$	$T_{2M}$ [Nm]	P [kW]	$T_2$ [Nm]	$P_1$ [kW]	FS'	Input - IEC					
										XC B5/B14	XF				
Kg 1.4	5	560	0.89	—	14	0.92	5.6	0.37	2.5	63	56	63	56	63	56
	7.5	373	0.86		16	0.72	8	0.37	2.0						
	10	280	0.84		16	0.56	11	0.37	1.5						
	15	187	0.81		17	0.41	15	0.37	1.1						
	20	140	0.76		15	0.29	13	0.25	1.2						
	25	112	0.74		16	0.25	16	0.25	1.0						
	30	93	0.71		13	0.18	13	0.18	1.0						
	40	70	0.65		16	0.18	16	0.18	1.0						
	50	56	0.62		15	0.14	14	0.13	1.1						
	65	43	0.57		17	0.13	17	0.13	1.0						
	80	35	0.54		13	0.09	13	0.09	1.0						
100	28	0.52	12	0.07	16	0.09	0.8	—							

30	$n_1 = 1400$				XA		XC - XF								
	$i_n$	$n_2$ [min <sup>-1</sup> ]	Rd	$P_{10}$	$T_{2M}$ [Nm]	P [kW]	$T_2$ [Nm]	$P_1$ [kW]	FS'	Input - IEC					
										XC B5/B14	XF				
Kg 1.4	5	280	0.87	0.40	19	0.64	6.5	0.22	2.9	63	56	63	56	63	56
	7.5	187	0.84	0.40	21	0.49	9	0.22	2.2						
	10	140	0.82	0.40	22	0.40	12	0.22	1.8						
	15	93	0.77	0.30	22	0.28	17	0.22	1.3						
	20	70	0.72	0.20	19	0.19	18	0.18	1.1						
	25	56	0.69	0.20	21	0.18	21	0.18	1.0						
	30	47	0.66	0.20	20	0.15	18	0.13	1.1						
	40	35	0.59	0.20	21	0.13	21	0.13	1.0						
	50	28	0.55	0.20	19	0.10	17	0.09	1.1						
	65	22	0.51	0.10	20	0.09	20	0.09	1.0						
	80	18	0.48	0.10	17	0.06	16	0.06	1.0						
100	14	0.45	0.10	14	0.05	18	0.06	0.8	—						

30	$n_1 = 900$				XA		XC - XF								
	$i_n$	$n_2$ [min <sup>-1</sup> ]	Rd	$P_{10}$	$T_{2M}$ [Nm]	P [kW]	$T_2$ [Nm]	$P_1$ [kW]	FS'	Input - IEC					
										XC B5/B14	XF				
Kg 1.4	5	180	0.85	—	23	0.51	5.9	0.13	3.9	63	56	63	56	63	56
	7.5	120	0.82		25	0.38	9	0.13	2.9						
	10	90	0.80		25	0.30	11	0.13	2.3						
	15	60	0.75		25	0.21	15	0.13	1.6						
	20	45	0.69		22	0.15	19	0.13	1.2						
	25	36	0.66		24	0.14	23	0.13	1.1						
	30	30	0.63		21	0.10	18	0.09	1.2						
	40	23	0.55		24	0.10	21	0.09	1.1						
	50	18	0.52		21	0.08	16	0.06	1.1						
	65	14	0.48		22	0.07	20	0.06	1.1						
	80	11	0.44		19	0.05	11	0.03	1.7						
100	9	0.42	15	0.03	13	0.03	1.1	—							

30	$n_1 = 500$				XA		XC - XF								
	$i_n$	$n_2$ [min <sup>-1</sup> ]	Rd	$P_{10}$	$T_{2M}$ [Nm]	P [kW]	$T_2$ [Nm]	$P_1$ [kW]	FS'	Input - IEC					
										XC B5/B14	XF				
Kg 1.4	5	100	0.83	—	29	0.36	—	—	—	63	56	63	56	63	56
	7.5	67	0.80		31	0.27	—	—	—						
	10	50	0.77		31	0.21	—	—	—						
	15	33	0.72		31	0.15	—	—	—						
	20	25	0.66		26	0.10	—	—	—						
	25	20	0.62		27	0.09	—	—	—						
	30	17	0.59		25	0.07	—	—	—						
	40	13	0.51		28	0.07	—	—	—						
	50	10	0.48		25	0.06	—	—	—						
	65	8	0.43		25	0.05	—	—	—						
	80	6	0.40		20	0.03	—	—	—						
100	5	0.38	16	0.02	—	—	—	—							

\* **ATTENZIONE:** la coppia massima utilizzabile  $[T_{2M}]$  deve essere calcolata utilizzando il fattore di servizio:  $T_{2M} = T_2 \times FS'$

\* **WARNING:** Maximum allowable torque  $[T_{2M}]$  must be calculated using the following service factor:  $T_{2M} = T_2 \times FS'$

\* **ВНИМАНИЕ:** максимально используемый крутящий момент  $[T_{2M}]$  должен быть рассчитан с помощью сервис-фактора:  $T_{2M} = T_2 \times FS'$

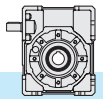

2.5 Dati tecnici

2.5 Technical data

2.5 Технические данные

40	$n_1 = 2800$				XA		XC - XF											
	$i_n$	$n_2$ [min <sup>-1</sup> ]	Rd	$P_{10}$	$T_{2M}$ [Nm]	P [kW]	$T_2$ [Nm]	$P_1$ [kW]	FS'	XC			Input - IEC					
										B5/B14			B5		XF			B14
Kg 2.4	5	560	0.88	—	25	1.67	11.3	0.75	2.2	71	63	—	71	63	56	71	63	—
	7.5	373	0.87		30	1.3	17	0.75	1.8									
	10	280	0.86		31	1.1	22	0.75	1.4									
	15	187	0.82		32	0.76	32	0.75	1.0									
	20	140	0.80		31	0.57	30	0.55	1.0									
	25	112	0.76		27	0.41	24	0.37	1.1									
	30	93	0.73		35	0.47	28	0.37	1.3									
	40	70	0.70		33	0.35	24	0.25	1.4									
	50	56	0.65		30	0.27	28	0.25	1.1									
	65	43	0.61		28	0.21	24	0.18	1.2									
80	35	0.58	26	0.16	21	0.13	1.3											
100	28	0.55	25	0.13	24	0.13	1.0											

40	$n_1 = 1400$				XA		XC - XF											
	$i_n$	$n_2$ [min <sup>-1</sup> ]	Rd	$P_{10}$	$T_{2M}$ [Nm]	P [kW]	$T_2$ [Nm]	$P_1$ [kW]	FS'	XC			Input - IEC					
										B5/B14			B5		XF			B14
Kg 2.4	5	280	0.87	0.80	34	1.14	16.3	0.55	2.1	71	63	—	71	63	56	71	63	—
	7.5	187	0.85	0.80	40	0.92	24	0.55	1.7									
	10	140	0.83	0.70	41	0.73	31	0.55	1.3									
	15	93	0.79	0.50	42	0.52	30	0.37	1.4									
	20	70	0.76	0.50	40	0.39	38	0.37	1.0									
	25	56	0.72	0.40	35	0.29	31	0.25	1.1									
	30	47	0.68	0.40	41	0.29	35	0.25	1.2									
	40	35	0.64	0.30	38	0.22	38	0.22	1.0									
	50	28	0.59	0.30	38	0.19	36	0.18	1.1									
	65	22	0.54	0.20	35	0.15	31	0.13	1.1									
80	18	0.52	0.20	33	0.12	31	0.11	1.1										
100	14	0.49	0.20	28	0.08	30	0.09	0.9										

40	$n_1 = 900$				XA		XC - XF											
	$i_n$	$n_2$ [min <sup>-1</sup> ]	Rd	$P_{10}$	$T_{2M}$ [Nm]	P [kW]	$T_2$ [Nm]	$P_1$ [kW]	FS'	XC			Input - IEC					
										B5/B14			B5		XF			B14
Kg 2.4	5	180	0.85	—	42	0.93	16.7	0.37	2.5	71	63	—	71	63	56	71	63	—
	7.5	120	0.83		48	0.72	25	0.37	2.0									
	10	90	0.81		48	0.56	32	0.37	1.5									
	15	60	0.76		49	0.40	45	0.37	1.1									
	20	45	0.74		46	0.29	39	0.25	1.2									
	25	36	0.69		42	0.23	33	0.18	1.3									
	30	30	0.65		48	0.23	37	0.18	1.3									
	40	23	0.61		42	0.16	33	0.13	1.3									
	50	18	0.55		42	0.14	38	0.13	1.1									
	65	14	0.51		39	0.11	32	0.09	1.2									
80	11	0.48	37	0.09	37	0.09	1.0											
100	9	0.45	30	0.06	29	0.06	1.0											

40	$n_1 = 500$				XA		XC - XF											
	$i_n$	$n_2$ [min <sup>-1</sup> ]	Rd	$P_{10}$	$T_{2M}$ [Nm]	P [kW]	$T_2$ [Nm]	$P_1$ [kW]	FS'	XC			Input - IEC					
										B5/B14			B5		XF			B14
Kg 2.4	5	100	0.83	—	51	0.64	7.1	0.09	7.1	71	63	—	71	63	56	71	63	—
	7.5	67	0.81		58	0.50	10	0.09	5.5									
	10	50	0.79		59	0.39	14	0.09	4.4									
	15	33	0.73		59	0.28	19	0.09	3.1									
	20	25	0.70		55	0.20	24	0.09	2.3									
	25	20	0.65		48	0.15	28	0.09	1.7									
	30	17	0.61		58	0.17	31	0.09	1.8									
	40	13	0.57		52	0.12	39	0.09	1.3									
	50	10	0.51		51	0.11	44	0.09	1.2									
	65	8	0.46		45	0.08	52	0.09	0.9									
80	6	0.44	42	0.06	61*	0.09	0.7*											
100	5	0.41	32	0.04	71*	0.09	0.4*											

\* **ATTENZIONE:** la coppia massima utilizzabile  $[T_{2M}]$  deve essere calcolata utilizzando il fattore di servizio:  $T_{2M} = T_2 \times FS'$

\* **WARNING:** Maximum allowable torque  $[T_{2M}]$  must be calculated using the following service factor:  $T_{2M} = T_2 \times FS'$

\* **ВНИМАНИЕ:** максимально используемый крутящий момент  $[T_{2M}]$  должен быть рассчитан с помощью сервис-фактора:  $T_{2M} = T_2 \times FS'$



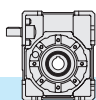

2.5 Dati tecnici

2.5 Technical data

2.5 Технические данные

50	$n_1 = 2800$				XA		XC - XF											
	$i_n$	$n_2$ [min <sup>-1</sup> ]	Rd	$P_{10}$	$T_{2M}$ [Nm]	P [kW]	$T_2$ [Nm]	$P_1$ [kW]	FS'	XC			Input - IEC					
										B5/B14			B5		XF			B14
Kg 4.0	5	560	0.89	—	44	2.9	22.8	1.5	1.9	80	71	—	80	71	63	80	71	—
	7.5	373	0.88		51	2.3	34	1.5	1.5									
	10	280	0.86		54	1.8	44	1.5	1.2									
	15	187	0.84		57	1.3	47	1.1	1.2									
	20	140	0.81		58	1.0	42	0.75	1.4									
	25	112	0.78		50	0.75	50	0.75	1.0									
	30	93	0.75		55	0.71	42	0.55	1.3									
	40	70	0.72		54	0.63	54	0.55	1.0									
	50	56	0.68		56	0.48	43	0.37	1.3									
	65	43	0.64		53	0.37	53	0.37	1.0									
80	35	0.61	48	0.29	41	0.25	1.2	—										
100	28	0.58	45	0.23	35	0.18	1.3											

50	$n_1 = 1400$				XA		XC - XF											
	$i_n$	$n_2$ [min <sup>-1</sup> ]	Rd	$P_{10}$	$T_{2M}$ [Nm]	P [kW]	$T_2$ [Nm]	$P_1$ [kW]	FS'	XC			Input - IEC					
										B5/B14			B5		XF			B14
Kg 4.0	5	280	0.87	1.2	62	2.1	26.7	0.9	2.3	80	71	—	80	71	63	80	71	—
	7.5	187	0.86	1.2	70	1.6	40	0.9	1.8									
	10	140	0.84	1.0	73	1.3	52	0.9	1.4									
	15	93	0.80	0.80	74	0.90	74	0.9	1.0									
	20	70	0.78	0.70	75	0.71	58	0.55	1.3									
	25	56	0.74	0.60	65	0.51	47	0.37	1.4									
	30	47	0.71	0.60	66	0.46	53	0.37	1.2									
	40	35	0.67	0.50	69	0.38	68	0.37	1.0									
	50	28	0.62	0.40	70	0.33	53	0.25	1.3									
	65	22	0.58	0.40	64	0.25	64	0.25	1.0									
80	18	0.54	0.40	60	0.20	53	0.18	1.1										
100	14	0.51	0.30	55	0.16	45	0.13	1.2										

50	$n_1 = 900$				XA		XC - XF											
	$i_n$	$n_2$ [min <sup>-1</sup> ]	Rd	$P_{10}$	$T_{2M}$ [Nm]	P [kW]	$T_2$ [Nm]	$P_1$ [kW]	FS'	XC			Input - IEC					
										B5/B14			B5		XF			B14
Kg 4.0	5	180	0.85	—	75	1.66	33.8	0.75	2.2	80	71	—	80	71	63	80	71	—
	7.5	120	0.84		83	1.23	50	0.75	1.6									
	10	90	0.82		86	0.98	66	0.75	1.3									
	15	60	0.78		88	0.71	68	0.55	1.3									
	20	45	0.75		87	0.54	59	0.37	1.5									
	25	36	0.71		75	0.40	70	0.37	1.1									
	30	30	0.67		79	0.37	79	0.37	1.0									
	40	23	0.63		75	0.28	67	0.25	1.1									
	50	18	0.59		80	0.26	78	0.25	1.0									
	65	14	0.54		74	0.20	67	0.18	1.1									
80	11	0.51	67	0.16	56	0.13	1.2											
100	9	0.47	58	0.12	45	0.09	1.3											

50	$n_1 = 500$				XA		XC - XF											
	$i_n$	$n_2$ [min <sup>-1</sup> ]	Rd	$P_{10}$	$T_{2M}$ [Nm]	P [kW]	$T_2$ [Nm]	$P_1$ [kW]	FS'	XC			Input - IEC					
										B5/B14			B5		XF			B14
Kg 4.0	5	100	0.84	—	92	1.15	14.3	0.18	6.4	80	71	—	80	71	63	80	71	—
	7.5	67	0.82		100	0.85	21	0.18	4.7									
	10	50	0.80		104	0.68	28	0.18	3.8									
	15	33	0.75		106	0.49	39	0.18	2.7									
	20	25	0.72		104	0.38	50	0.18	2.1									
	25	20	0.68		88	0.27	58	0.18	1.5									
	30	17	0.63		98	0.27	65	0.18	1.5									
	40	13	0.59		95	0.21	81	0.18	1.2									
	50	10	0.54		94	0.18	93	0.18	1.0									
	65	8	0.50		86	0.14	56	0.09	1.5									
80	6	0.46	77	0.11	63	0.09	1.2											
100	5	0.43	61	0.07	74	0.09	0.8											

\* **ATTENZIONE:** la coppia massima utilizzabile  $[T_{2M}]$  deve essere calcolata utilizzando il fattore di servizio:  $T_{2M} = T_2 \times FS'$

\* **WARNING:** Maximum allowable torque  $[T_{2M}]$  must be calculated using the following service factor:  $T_{2M} = T_2 \times FS'$

\* **ВНИМАНИЕ:** максимально используемый крутящий момент  $[T_{2M}]$  должен быть рассчитан с помощью сервис-фактора:  $T_{2M} = T_2 \times FS'$

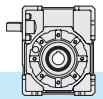

2.5 Dati tecnici

2.5 Technical data

2.5 Технические данные

63	$n_1 = 2800$				XA		XC - XF										
	$i_n$	$n_2$ [min <sup>-1</sup> ]	Rd	$P_{10}$	$T_{2M}$ [Nm]	P [kW]	$T_2$ [Nm]	$P_1$ [kW]	FS'	XC			Input - IEC				
										XF			B5		B14		
	B5/B14			B5		B14											
5	560	0.89	—	79	5.2	45.5	3	1.7	90	80	—	90	80	71	90	80	—
7.5	373	0.88		88	3.9	68	3	1.3									
10	280	0.87		94	3.2	89	3	1.1									
15	187	0.84		98	2.3	95	2.2	1.0									
20	140	0.83		110	1.9	85	1.5	1.3									
25	112	0.81		93	1.4	76	1.1	1.2									
30	93	0.77		110	1.4	87	1.1	1.3									
40	70	0.74		117	1.2	111	1.1	1.1									
50	56	0.70		97	0.81	90	0.75	1.1									
65	43	0.67		98	0.66	81	0.55	1.2									
80	35	0.64		91	0.52	65	0.37	1.4									
100	28	0.60		83	0.41	75	0.37	1.1									

 6.6

63	$n_1 = 1400$				XA		XC - XF										
	$i_n$	$n_2$ [min <sup>-1</sup> ]	Rd	$P_{10}$	$T_{2M}$ [Nm]	P [kW]	$T_2$ [Nm]	$P_1$ [kW]	FS'	XC			Input - IEC				
										XF			B5		B14		
	B5/B14			B5		B14											
5	280	0.88	1.8	111	3.7	54	1.8	2.0	90	80	—	90	80	71	90	80	—
7.5	187	0.87	1.8	120	2.7	80	1.8	1.5									
10	140	0.85	1.6	127	2.2	105	1.8	1.2									
15	93	0.81	1.2	130	1.6	125	1.5	1.1									
20	70	0.80	1.2	144	1.3	120	1.1	1.2									
25	56	0.77	1.0	118	0.90	118	0.9	1.0									
30	47	0.73	0.90	142	0.95	134	0.9	1.1									
40	35	0.69	0.80	150	0.79	142	0.75	1.1									
50	28	0.65	0.70	122	0.55	122	0.55	1.0									
65	22	0.61	0.60	122	0.45	100	0.37	1.2									
80	18	0.58	0.60	113	0.36	79	0.25	1.4									
100	14	0.53	0.50	102	0.28	91	0.25	1.1									

 6.6

63	$n_1 = 900$				XA		XC - XF										
	$i_n$	$n_2$ [min <sup>-1</sup> ]	Rd	$P_{10}$	$T_{2M}$ [Nm]	P [kW]	$T_2$ [Nm]	$P_1$ [kW]	FS'	XC			Input - IEC				
										XF			B5		B14		
	B5/B14			B5		B14											
5	180	0.87	—	135	2.9	69	1.5	1.9	90	80	—	90	80	71	90	80	—
7.5	120	0.85		144	2.1	102	1.5	1.4									
10	90	0.83		150	1.7	133	1.5	1.1									
15	60	0.79		152	1.2	139	1.1	1.1									
20	45	0.77		167	1.0	123	0.75	1.4									
25	36	0.74		140	0.71	109	0.55	1.3									
30	30	0.70		164	0.74	122	0.55	1.3									
40	23	0.66		171	0.61	154	0.55	1.1									
50	18	0.61		141	0.44	120	0.37	1.2									
65	14	0.57		139	0.35	98	0.25	1.4									
80	11	0.54		128	0.28	115	0.25	1.1									
100	9	0.50		115	0.22	95	0.18	1.2									

 6.6

63	$n_1 = 500$				XA		XC - XF										
	$i_n$	$n_2$ [min <sup>-1</sup> ]	Rd	$P_{10}$	$T_{2M}$ [Nm]	P [kW]	$T_2$ [Nm]	$P_1$ [kW]	FS'	XC			Input - IEC				
										XF			B5		B14		
	B5/B14			B5		B14											
5	100	0.85	—	169	2.08	20	0.25	8.3	90	80	—	90	80	71	90	80	—
7.5	67	0.83		177	1.5	30	0.25	5.9									
10	50	0.81		182	1.2	39	0.25	4.7									
15	33	0.76		184	0.84	55	0.25	3.4									
20	25	0.74		200	0.70	71	0.25	2.8									
25	20	0.71		165	0.49	85	0.25	1.9									
30	17	0.65		195	0.52	94	0.25	2.1									
40	13	0.62		201	0.43	118	0.25	1.7									
50	10	0.56		165	0.31	135	0.25	1.2									
65	8	0.52		161	0.25	163	0.25	1.0									
80	6	0.50		148	0.19	137	0.18	1.1									
100	5	0.45		122	0.14	77	0.09	1.6									

 6.6

\* **ATTENZIONE:** la coppia massima utilizzabile  $[T_{2M}]$  deve essere calcolata utilizzando il fattore di servizio:  $T_{2M} = T_2 \times FS'$

\* **WARNING:** Maximum allowable torque  $[T_{2M}]$  must be calculated using the following service factor:  $T_{2M} = T_2 \times FS'$

\* **ВНИМАНИЕ:** максимально используемый крутящий момент  $[T_{2M}]$  должен быть рассчитан с помощью сервис-фактора:  $T_{2M} = T_2 \times FS'$

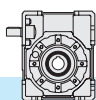

2.5 Dati tecnici

2.5 Technical data

2.5 Технические данные

75	$n_1 = 2800$				XA		XC - XF												
	$i_n$	$n_2$ [min <sup>-1</sup> ]	Rd	$P_{10}$	$T_{2M}$ [Nm]	P [kW]	$T_2$ [Nm]	$P_1$ [kW]	FS'	Input - IEC									
										XC			XF						
	B5/B14			B5			B14												
7.5	373	0.89	—	131	5.8	125	5.5	1.0	112 100	90	—	—	112 100	90	80	112 100	90	—	
10	280	0.88		143	4.8	120	4	1.2											
15	187	0.85		152	3.5	131	3	1.2											
20	140	0.84		172	3.0	171	3	1.0											
25	112	0.82		155	2.2	154	2.2	1.0											
30	93	0.78		170	2.1	120	1.5	1.4											
40	70	0.75		183	1.8	154	1.5	1.2											
50	56	0.73		166	1.3	136	1.1	1.2											
65	43	0.69		155	1.0	114	0.75	1.4											
80	35	0.66		145	0.80	135	0.75	1.1											
100	28	0.62		131	0.62	159	0.75	0.8											



75	$n_1 = 1400$				XA		XC - XF												
	$i_n$	$n_2$ [min <sup>-1</sup> ]	Rd	$P_{10}$	$T_{2M}$ [Nm]	P [kW]	$T_2$ [Nm]	$P_1$ [kW]	FS'	Input - IEC									
										XC			XF						
	B5/B14			B5			B14												
7.5	187	0.87	2.5	180	4.0	178	4	1.0	112 100	90	—	—	112 100	90	80	112 100	90	—	
10	140	0.86	2.3	193	3.3	176	3	1.1											
15	93	0.83	1.9	202	2.4	187	2.2	1.1											
20	70	0.81	1.7	226	2.0	199	1.8	1.1											
25	56	0.78	1.5	202	1.5	200	1.5	1.0											
30	47	0.74	1.2	220	1.5	167	1.1	1.3											
40	35	0.71	1.1	235	1.2	213	1.1	1.1											
50	28	0.67	1.0	211	0.92	206	0.9	1.0											
65	22	0.63	0.90	195	0.70	154	0.55	1.3											
80	18	0.60	0.80	182	0.55	180	0.55	1.0											
100	14	0.56	0.70	162	0.43	210	0.55	0.8											



75	$n_1 = 900$				XA		XC - XF												
	$i_n$	$n_2$ [min <sup>-1</sup> ]	Rd	$P_{10}$	$T_{2M}$ [Nm]	P [kW]	$T_2$ [Nm]	$P_1$ [kW]	FS'	Input - IEC									
										XC			XF						
	B5/B14			B5			B14												
7.5	120	0.86	—	215	3.1	205	3	1.0	112 100	90	—	—	112 100	90	80	112 100	90	—	
10	90	0.84		229	2.6	197	2.2	1.2											
15	60	0.81		237	1.9	231	1.8	1.0											
20	45	0.78		263	1.6	250	1.5	1.1											
25	36	0.76		233	1.2	221	1.1	1.1											
30	30	0.71		254	1.1	249	1.1	1.0											
40	23	0.67		270	0.94	214	0.75	1.3											
50	18	0.64		241	0.71	186	0.55	1.3											
65	14	0.59		221	0.54	151	0.37	1.5											
80	11	0.56		205	0.43	177	0.37	1.2											
100	9	0.52		184	0.34	203	0.37	0.9											



75	$n_1 = 500$				XA		XC - XF												
	$i_n$	$n_2$ [min <sup>-1</sup> ]	Rd	$P_{10}$	$T_{2M}$ [Nm]	P [kW]	$T_2$ [Nm]	$P_1$ [kW]	FS'	Input - IEC									
										XC			XF						
	B5/B14			B5			B14												
7.5	67	0.84	—	265	2.2	90	0.75	2.9	112 100	90	—	—	112 100	90	80	112 100	90	—	
10	50	0.82		279	1.8	118	0.75	2.4											
15	33	0.78		286	1.3	167	0.75	1.7											
20	25	0.75		315	1.1	216	0.75	1.5											
25	20	0.72		278	0.80	260	0.75	1.1											
30	17	0.67		302	0.79	288	0.75	1.1											
40	13	0.63		317	0.66	265	0.55	1.2											
50	10	0.59		282	0.50	210	0.37	1.3											
65	8	0.55		257	0.38	251	0.37	1.0											
80	6	0.52		238	0.30	197	0.25	1.2											
100	5	0.47		206	0.23	161	0.18	1.3											



\* **ATTENZIONE:** la coppia massima utilizzabile  $[T_{2M}]$  deve essere calcolata utilizzando il fattore di servizio:  $T_{2M} = T_2 \times FS'$

\* **WARNING:** Maximum allowable torque  $[T_{2M}]$  must be calculated using the following service factor:  $T_{2M} = T_2 \times FS'$

\* **ВНИМАНИЕ:** максимально используемый крутящий момент  $[T_{2M}]$  должен быть рассчитан с помощью сервис-фактора:  $T_{2M} = T_2 \times FS'$

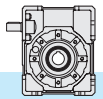

2.5 Dati tecnici

2.5 Technical data

2.5 Технические данные

89	<b>n<sub>1</sub> = 2800</b>				<b>XC</b>					
	i <sub>n</sub>	n <sub>2</sub> [min. <sup>-1</sup> ]	Rd	P <sub>10</sub>	T <sub>2</sub> [Nm]	P <sub>1</sub> [kW]	FS'	Input - IEC		
								XC B5/B14		
Kg 13.0	7.5	373	0.89	—	171	7.5	1.2	112 100	90	—
	10	280	0.88		165	5.5	1.3			
	15	187	0.86		241	5.5	1.0			
	20	140	0.84		230	4	1.2			
	25	112	0.83		212	3	1.2			
	30	93	0.79		243	3	1.1			
	40	70	0.77		230	2.2	1.3			
	50	56	0.74		278	2.2	1.0			
	65	43	0.71		235	1.5	1.1			
	80	35	0.68		205	1.1	1.2			
100	28	0.64	163	0.75	1.3	—	80			

89	<b>n<sub>1</sub> = 1400</b>				<b>XC</b>					
	i <sub>n</sub>	n <sub>2</sub> [min. <sup>-1</sup> ]	Rd	P <sub>10</sub>	T <sub>2</sub> [Nm]	P <sub>1</sub> [kW]	FS'	Input - IEC		
								XC B5/B14		
Kg 13.0	7.5	187	0.88	3.0	247	5.5	1.2	112 100	90	—
	10	140	0.86	2.5	236	4	1.3			
	15	93	0.84	2.2	256	3	1.2			
	20	70	0.82	2.0	334	3	1.1			
	25	56	0.80	1.8	299	2.2	1.1			
	30	47	0.76	1.5	340	2.2	1.0			
	40	35	0.72	1.3	355	1.8	1.1			
	50	28	0.69	1.1	353	1.5	1.0			
	65	22	0.65	1.0	317	1.1	1.0			
	80	18	0.63	1.0	309	0.9	1.0			
100	14	0.58	0.80	217	0.55	1.2	—	80		

89	<b>n<sub>1</sub> = 900</b>				<b>XC</b>					
	i <sub>n</sub>	n <sub>2</sub> [min. <sup>-1</sup> ]	Rd	P <sub>10</sub>	T <sub>2</sub> [Nm]	P <sub>1</sub> [kW]	FS'	Input - IEC		
								XC B5/B14		
Kg 13.0	7.5	120	0.86	—	206	3	1.7	112 100	90	—
	10	90	0.85		270	3	1.3			
	15	60	0.82		286	2.2	1.3			
	20	45	0.79		371	2.2	1.1			
	25	36	0.77		369	1.8	1.0			
	30	30	0.73		416	1.8	1.0			
	40	23	0.69		440	1.5	1.0			
	50	18	0.66		384	1.1	1.0			
	65	14	0.62		319	0.75	1.1			
	80	11	0.59		274	0.55	1.2			
100	9	0.54	313	0.55	1.0	—	80			

89	<b>n<sub>1</sub> = 500</b>				<b>XC</b>					
	i <sub>n</sub>	n <sub>2</sub> [min. <sup>-1</sup> ]	Rd	P <sub>10</sub>	T <sub>2</sub> [Nm]	P <sub>1</sub> [kW]	FS'	Input - IEC		
								XC B5/B14		
Kg 13.0	7.5	67	0.84	—	91	0.75	4.7	112 100	90	—
	10	50	0.83		118	0.75	3.7			
	15	33	0.79		169	0.75	2.7			
	20	25	0.76		219	0.75	2.3			
	25	20	0.74		265	0.75	1.7			
	30	17	0.68		294	0.75	1.6			
	40	13	0.65		371	0.75	1.4			
	50	10	0.61		439	0.75	1.1			
	65	8	0.57		388	0.55	1.1			
	80	6	0.54		305	0.37	1.3			
100	5	0.49	344	0.37	1.0	—	80			

\* **ATTENZIONE:** la coppia massima utilizzabile [T<sub>2M</sub>] deve essere calcolata utilizzando il fattore di servizio: T<sub>2M</sub> = T<sub>2</sub> x FS'

\* **WARNING:** Maximum allowable torque [T<sub>2M</sub>] must be calculated using the following service factor : T<sub>2M</sub> = T<sub>2</sub> x FS'

\* **ВНИМАНИЕ:** максимально используемый крутящий момент [T<sub>2M</sub>] должен быть рассчитан с помощью сервис-фактора: T<sub>2M</sub> = T<sub>2</sub> x FS'

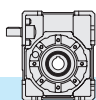

2.5 Dati tecnici

2.5 Technical data

2.5 Технические данные

90	$n_1 = 2800$				XA		XC - XF											
	$i_n$	$n_2$ [min <sup>-1</sup> ]	Rd	$P_{10}$	$T_{2M}$ [Nm]	P [kW]	$T_2$ [Nm]	$P_1$ [kW]	FS'	XC		Input - IEC						
										B5/B14		B5			XF			
Kg 23.6	7.5	373	0.89	—	209	9.2	171	7.5	1.2	112 100	90	—	112 100	90	80	112 100	90	—
	10	280	0.88		223	7.4	165	5.5	1.3									
	15	187	0.86		241	5.5	241	5.5	1.0									
	20	140	0.84		272	4.7	230	4	1.2									
	25	112	0.83		255	3.6	212	3	1.2									
	30	93	0.79		270	3.3	243	3	1.1									
	40	70	0.77		293	2.8	230	2.2	1.3									
	50	56	0.74		278	2.2	278	2.2	1.0									
	65	43	0.71		250	1.6	235	1.5	1.1									
	80	35	0.68		238	1.3	205	1.1	1.2									
100	28	0.64	212	0.97	163	0.75	1.3	—	80									

90	$n_1 = 1400$				XA		XC - XF											
	$i_n$	$n_2$ [min <sup>-1</sup> ]	Rd	$P_{10}$	$T_{2M}$ [Nm]	P [kW]	$T_2$ [Nm]	$P_1$ [kW]	FS'	XC		Input - IEC						
										B5/B14		B5			XF			
Kg 23.6	7.5	187	0.88	3.0	290	6.5	247	5.5	1.2	112 100	90	—	112 100	90	80	112 100	90	—
	10	140	0.86	2.5	305	5.2	236	4	1.3									
	15	93	0.84	2.2	320	3.7	256	3	1.2									
	20	70	0.82	2.0	360	3.2	334	3	1.1									
	25	56	0.80	1.8	332	2.4	299	2.2	1.1									
	30	47	0.76	1.5	350	2.3	340	2.2	1.0									
	40	35	0.72	1.3	377	1.9	355	1.8	1.1									
	50	28	0.69	1.1	353	1.5	353	1.5	1.0									
	65	22	0.65	1.0	317	1.1	317	1.1	1.0									
	80	18	0.63	1.0	309	0.90	309	0.9	1.0									
100	14	0.58	0.80	264	0.67	217	0.55	1.2	—	80								

90	$n_1 = 900$				XA		XC - XF											
	$i_n$	$n_2$ [min <sup>-1</sup> ]	Rd	$P_{10}$	$T_{2M}$ [Nm]	P [kW]	$T_2$ [Nm]	$P_1$ [kW]	FS'	XC		Input - IEC						
										B5/B14		B5			XF			
Kg 23.6	7.5	120	0.86	—	345	5.0	206	3	1.7	112 100	90	—	112 100	90	80	112 100	90	—
	10	90	0.85		362	4.0	270	3	1.3									
	15	60	0.82		377	2.9	286	2.2	1.3									
	20	45	0.79		419	2.5	371	2.2	1.1									
	25	36	0.77		385	1.9	369	1.8	1.0									
	30	30	0.73		416	1.8	416	1.8	1.0									
	40	23	0.69		440	1.5	440	1.5	1.0									
	50	18	0.66		398	1.1	384	1.1	1.0									
	65	14	0.62		358	0.84	319	0.75	1.1									
	80	11	0.59		337	0.68	274	0.55	1.2									
100	9	0.54	313	0.55	313	0.55	1.0	—	80									

90	$n_1 = 500$				XA		XC - XF											
	$i_n$	$n_2$ [min <sup>-1</sup> ]	Rd	$P_{10}$	$T_{2M}$ [Nm]	P [kW]	$T_2$ [Nm]	$P_1$ [kW]	FS'	XC		Input - IEC						
										B5/B14		B5			XF			
Kg 23.6	7.5	67	0.84	—	430	3.6	91	0.75	4.7	112 100	90	—	112 100	90	80	112 100	90	—
	10	50	0.83		443	2.8	118	0.75	3.7									
	15	33	0.79		456	2.0	169	0.75	2.7									
	20	25	0.76		502	1.7	219	0.75	2.3									
	25	20	0.74		459	1.3	265	0.75	1.7									
	30	17	0.68		483	1.2	294	0.75	1.6									
	40	13	0.65		512	1.0	371	0.75	1.4									
	50	10	0.61		467	0.80	439	0.75	1.1									
	65	8	0.57		417	0.59	388	0.55	1.1									
	80	6	0.54		391	0.48	305	0.37	1.3									
100	5	0.49	345	0.37	344	0.37	1.0	—	80									

\* **ATTENZIONE:** la coppia massima utilizzabile  $[T_{2M}]$  deve essere calcolata utilizzando il fattore di servizio:  $T_{2M} = T_2 \times FS'$

\* **WARNING:** Maximum allowable torque  $[T_{2M}]$  must be calculated using the following service factor:  $T_{2M} = T_2 \times FS'$

\* **ВНИМАНИЕ:** максимально используемый крутящий момент  $[T_{2M}]$  должен быть рассчитан с помощью сервис-фактора:  $T_{2M} = T_2 \times FS'$

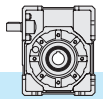

2.5 Dati tecnici

2.5 Technical data

2.5 Технические данные

110	$n_1 = 2800$				XA		XC - XF											
	$i_n$	$n_2$ [min <sup>-1</sup> ]	Rd	$P_{10}$	$T_{2M}$ [Nm]	P [kW]	$T_2$ [Nm]	$P_1$ [kW]	FS'	Input - IEC								
										XC			XF					
	B5/B14			B5			B14											
Kg 44.0	7.5	373	0.89	—	345	15.1	343	15	1.0	132	112 100	—	132	112 100	90	132	—	—
	10	280	0.88		368	12.2	332	11	1.1									
	15	187	0.86		404	9.2	331	7.5	1.2									
	20	140	0.85		465	8.0	435	7.5	1.1									
	25	112	0.84		441	6.2	393	5.5	1.1									
	30	93	0.80		459	5.6	450	5.5	1.0									
	40	70	0.78		503	4.7	424	4	1.2									
	50	56	0.76		476	3.7	388	3	1.2									
	65	43	0.73		417	2.6	354	2.2	1.2									
	80	35	0.70		400	2.1	287	1.5	1.4									
100	28	0.66	364	1.6	339	1.5	1.1	—	90	—	—	—	—	—	—	—		

110	$n_1 = 1400$				XA		XC - XF											
	$i_n$	$n_2$ [min <sup>-1</sup> ]	Rd	$P_{10}$	$T_{2M}$ [Nm]	P [kW]	$T_2$ [Nm]	$P_1$ [kW]	FS'	Input - IEC								
										XC			XF					
	B5/B14			B5			B14											
Kg 44.0	7.5	187	0.88	4.3	480	10.6	415	9.2	1.2	132	112 100	—	132	112 100	90	132	—	—
	10	140	0.87	4.0	504	8.5	446	7.5	1.1									
	15	93	0.84	3.2	543	6.3	475	5.5	1.1									
	20	70	0.83	3.0	623	5.5	623	5.5	1.0									
	25	56	0.81	2.7	578	4.2	554	4	1.0									
	30	47	0.77	2.2	601	3.8	472	3	1.3									
	40	35	0.74	2.0	650	3.2	606	3	1.1									
	50	28	0.72	1.8	608	2.5	538	2.2	1.1									
	65	22	0.68	1.6	528	1.8	451	1.5	1.2									
	80	18	0.65	1.5	503	1.4	390	1.1	1.3									
100	14	0.61	1.3	458	1.1	458	1.1	1.0	—	90	—	—	—	—	—	—		

110	$n_1 = 900$				XA		XC - XF											
	$i_n$	$n_2$ [min <sup>-1</sup> ]	Rd	$P_{10}$	$T_{2M}$ [Nm]	P [kW]	$T_2$ [Nm]	$P_1$ [kW]	FS'	Input - IEC								
										XC			XF					
	B5/B14			B5			B14											
Kg 44.0	7.5	120	0.87	—	578	8.3	381	5.5	1.5	132	112 100	—	132	112 100	90	132	—	—
	10	90	0.86		600	6.6	500	5.5	1.2									
	15	60	0.83		641	4.9	526	4	1.2									
	20	45	0.81		720	4.2	685	4	1.1									
	25	36	0.79		672	3.2	628	3	1.1									
	30	30	0.74		697	2.9	520	2.2	1.3									
	40	23	0.71		749	2.5	664	2.2	1.1									
	50	18	0.68		697	1.9	653	1.8	1.1									
	65	14	0.64		603	1.4	487	1.1	1.2									
	80	11	0.61		571	1.1	570	1.1	1.0									
100	9	0.57	513	0.85	450	0.75	1.1	—	90	—	—	—	—	—	—	—		

110	$n_1 = 500$				XA		XC - XF											
	$i_n$	$n_2$ [min <sup>-1</sup> ]	Rd	$P_{10}$	$T_{2M}$ [Nm]	P [kW]	$T_2$ [Nm]	$P_1$ [kW]	FS'	Input - IEC								
										XC			XF					
	B5/B14			B5			B14											
Kg 44.0	7.5	67	0.85	—	718	5.9	183	1.5	3.9	132	112 100	—	132	112 100	90	132	—	—
	10	50	0.84		738	4.6	240	1.5	3.1									
	15	33	0.80		778	3.4	344	1.5	2.3									
	20	25	0.78		866	2.9	446	1.5	1.9									
	25	20	0.76		802	2.2	542	1.5	1.5									
	30	17	0.70		832	2.1	603	1.5	1.4									
	40	13	0.67		886	1.7	765	1.5	1.2									
	50	10	0.64		820	1.3	671	1.1	1.2									
	65	8	0.59		705	0.96	553	0.75	1.3									
	80	6	0.56		664	0.77	643	0.75	1.0									
100	5	0.52	594	0.60	542	0.55	1.1	—	90	—	—	—	—	—	—	—		

\* **ATTENZIONE:** la coppia massima utilizzabile  $[T_{2M}]$  deve essere calcolata utilizzando il fattore di servizio:  $T_{2M} = T_2 \times FS'$

\* **WARNING:** Maximum allowable torque  $[T_{2M}]$  must be calculated using the following service factor:  $T_{2M} = T_2 \times FS'$

\* **ВНИМАНИЕ:** максимально используемый крутящий момент  $[T_{2M}]$  должен быть рассчитан с помощью сервис-фактора:  $T_{2M} = T_2 \times FS'$

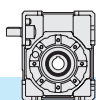

2.5 Dati tecnici

2.5 Technical data

2.5 Технические данные

130	$n_1 = 2800$				XA		XC - XF									
	$i_n$	$n_2$ [min <sup>-1</sup> ]	Rd	$P_{10}$	$T_{2M}$ [Nm]	P [kW]	$T_2$ [Nm]	$P_1$ [kW]	FS'	XC			Input - IEC			
										XF			XF			
	XC			XF												
B5/B14			B5			B14										
Kg 55.0	7.5	373	0.90	—	530	23	345	15	1.5	132	112 100	—	132	112 100	90	—
	10	280	0.89		549	18.1	455	15	1.2							
	15	187	0.87		636	14.3	490	11	1.3							
	20	140	0.86		733	12.5	645	11	1.1							
	25	112	0.85		710	9.8	667	9.2	1.1							
	30	93	0.81		729	8.8	622	7.5	1.2							
	40	70	0.80		819	7.5	819	7.5	1.0							
	50	56	0.78		758	5.7	732	5.5	1.0							
	65	43	0.75		648	3.9	499	3	1.3							
	80	35	0.73		637	3.2	598	3	1.1							
100	28	0.70	597	2.5	525	2.2	1.1									

130	$n_1 = 1400$				XA		XC - XF									
	$i_n$	$n_2$ [min <sup>-1</sup> ]	Rd	$P_{10}$	$T_{2M}$ [Nm]	P [kW]	$T_2$ [Nm]	$P_1$ [kW]	FS'	XC			Input - IEC			
										XF			XF			
	XC			XF												
B5/B14			B5			B14										
Kg 55.0	7.5	187	0.89	6.0	736	16.2	418	9.2	1.8	132	112 100	—	132	112 100	90	—
	10	140	0.88	5.5	756	12.6	552	9.2	1.4							
	15	93	0.85	4.4	855	9.8	803	9.2	1.1							
	20	70	0.84	4.1	974	8.5	860	7.5	1.1							
	25	56	0.83	3.9	920	6.5	778	5.5	1.2							
	30	47	0.79	3.2	947	5.9	883	5.5	1.1							
	40	35	0.76	2.8	1037	5.0	829	4	1.3							
	50	28	0.74	2.6	959	3.8	757	3	1.3							
	65	22	0.71	2.3	801	2.6	678	2.2	1.2							
	80	18	0.68	2.1	758	2.1	649	1.8	1.2							
100	14	0.64	1.8	699	1.6	655	1.5	1.1								

130	$n_1 = 900$				XA		XC - XF									
	$i_n$	$n_2$ [min <sup>-1</sup> ]	Rd	$P_{10}$	$T_{2M}$ [Nm]	P [kW]	$T_2$ [Nm]	$P_1$ [kW]	FS'	XC			Input - IEC			
										XF			XF			
	XC			XF												
B5/B14			B5			B14										
Kg 55.0	7.5	120	0.88	—	889	12.7	385	5.5	2.3	132	112 100	—	132	112 100	90	—
	10	90	0.87		905	9.8	508	5.5	1.8							
	15	60	0.84		1016	7.6	735	5.5	1.4							
	20	45	0.82		1149	6.6	957	5.5	1.2							
	25	36	0.81		1074	5.0	860	4	1.3							
	30	30	0.76		1113	4.6	968	4	1.2							
	40	23	0.73		1208	3.9	930	3	1.3							
	50	18	0.70		1077	2.9	817	2.2	1.3							
	65	14	0.67		924	2.0	832	1.8	1.1							
	80	11	0.64		869	1.6	815	1.5	1.1							
100	9	0.60	828	1.3	700	1.1	1.2									

130	$n_1 = 500$				XA		XC - XF									
	$i_n$	$n_2$ [min <sup>-1</sup> ]	Rd	$P_{10}$	$T_{2M}$ [Nm]	P [kW]	$T_2$ [Nm]	$P_1$ [kW]	FS'	XC			Input - IEC			
										XF			XF			
	XC			XF												
B5/B14			B5			B14										
Kg 55.0	7.5	67	0.86	—	1109	9.0	228	1.85	4.9	132	112 100	—	132	112 100	90	—
	10	50	0.84		1107	6.9	297	1.85	3.7							
	15	33	0.81		1230	5.3	429	1.85	2.9							
	20	25	0.79		1388	4.6	558	1.85	2.5							
	25	20	0.78		1266	3.4	689	1.85	1.8							
	30	17	0.72		1320	3.2	763	1.85	1.7							
	40	13	0.69		1423	2.7	975	1.85	1.5							
	50	10	0.66		1261	2.0	1166	1.85	1.1							
	65	8	0.63		1095	1.4	860	1.10	1.3							
	80	6	0.59		1082	1.2	992	1.10	1.1							
100	5	0.55	945	0.9	788	0.75	1.2									

\* **ATTENZIONE:** la coppia massima utilizzabile  $[T_{2M}]$  deve essere calcolata utilizzando il fattore di servizio:  $T_{2M} = T_2 \times FS'$

\* **WARNING:** Maximum allowable torque  $[T_{2M}]$  must be calculated using the following service factor:  $T_{2M} = T_2 \times FS'$

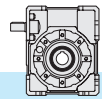

\* **ВНИМАНИЕ:** максимально используемый крутящий момент  $[T_{2M}]$  должен быть рассчитан с помощью сервис-фактора:  $T_{2M} = T_2 \times FS'$









2.6 **Momenti d'inerzia** [Kg·cm<sup>2</sup>]  
(riferiti all'albero veloce in entrata)

2.6 **Moments of inertia** [Kg·cm<sup>2</sup>]  
(referred to input shaft)

2.6 **Моменты инерции** [кг см<sup>2</sup>]  
(относятся к быстроходному входному валу)

X30	$i_n$	XA 	XC 		XF 	
			B5 - B14		B5 - B14	
			IEC 56	IEC 63	IEC 56	IEC 63
5	0.077	0.130	0.127	0.122	0.123	
7.5	0.058	0.112	0.109	0.102	0.103	
10	0.049	0.103	0.100	0.093	0.094	
15	0.042	0.097	0.094	0.087	0.087	
20	0.039	0.095	0.092	0.084	0.084	
25	0.038	0.094	0.091	0.083	0.083	
30	0.038	0.093	0.090	0.083	0.084	
40	0.037	0.093	0.090	0.082	0.082	
50	0.037	0.092	0.089	0.081	0.082	
65	0.024	0.079	-	0.069	0.069	
80	0.024	0.079	-	0.069	0.069	
100	0.024	0.078	-	0.069	0.069	

X40	$i_n$	XA 	XC 			XF 		
			B5 - B14			B5	B5 - B14	
			IEC 56	IEC 63	IEC 71	IEC 56	IEC 63	IEC 71
5	0.242	-	0.391	0.463	0.289	0.447	0.464	
7.5	0.170	-	0.321	0.356	0.217	0.375	0.391	
10	0.144	-	0.272	0.347	0.190	0.348	0.365	
15	0.125	-	0.266	0.340	0.171	0.329	0.346	
20	0.094	-	0.263	0.338	0.141	0.298	0.315	
25	0.091	-	0.262	0.337	0.137	0.295	0.312	
30	0.113	-	0.262	0.337	0.160	0.318	0.335	
40	0.087	-	0.261	-	0.134	0.292	0.309	
50	0.087	0.182	0.261	-	0.133	0.291	0.308	
65	0.069	0.182	0.261	-	0.116	0.274	0.290	
80	0.069	0.182	0.261	-	0.115	0.273	0.290	
100	0.068	0.182	0.261	-	0.115	0.273	0.290	

X50	$i_n$	XA 	XC 			XF 		
			B5 - B14			B5	B5 - B14	
			IEC 63	IEC 71	IEC 80	IEC 63	IEC 71	IEC 80
5	0.744	-	0.922	1.046	0.978	0.955	1.558	
7.5	0.499	-	0.684	0.935	0.733	0.750	1.313	
10	0.417	-	0.602	0.853	0.651	0.668	1.231	
15	0.358	-	0.543	0.794	0.593	0.609	1.173	
20	0.281	-	0.523	0.774	0.516	0.532	1.096	
25	0.272	-	0.513	0.764	0.506	0.523	1.086	
30	0.323	-	0.508	0.759	0.557	0.574	1.137	
40	0.262	0.315	0.503	-	0.496	0.513	1.076	
50	0.183	0.313	0.501	-	0.417	0.434	0.997	
65	0.136	0.311	0.499	-	0.370	0.387	0.950	
80	0.136	0.310	0.498	-	0.370	0.387	0.950	
100	0.135	0.309	0.498	-	0.370	0.386	0.950	











2.6 **Momenti d'inerzia** [Kg·cm<sup>2</sup>]  
(riferiti all'albero veloce in entrata)

2.6 **Moments of inertia** [Kg·cm<sup>2</sup>]  
(referred to input shaft)

2.6 **Моменты инерции** [кг см<sup>2</sup>]  
(относятся к быстроходному входному валу)

X63	i <sub>n</sub>	XA 	XC 			XF 		
			B5 - B14			B5	B5 - B14	
			IEC 71	IEC 80	IEC 90	IEC 71	IEC 80	IEC 90
5	1.853	-	2.431	2.671	2.632	2.766	3.844	
7.5	1.363	-	1.949	2.269	2.142	2.276	3.354	
10	1.158	-	1.744	2.063	1.936	2.070	3.148	
15	1.011	-	1.597	1.916	1.789	1.924	3.001	
20	0.710	-	1.545	1.864	1.489	1.623	2.701	
25	0.679	-	1.514	1.833	1.458	1.592	2.670	
30	0.922	-	1.508	1.828	1.701	1.835	2.913	
40	0.660	0.966	1.495	-	1.439	1.573	2.651	
50	0.653	0.959	1.488	-	1.431	1.565	2.643	
65	0.552	0.955	1.484	-	1.330	1.465	2.542	
80	0.550	0.953	1.482	-	1.329	1.463	2.541	
100	0.549	0.952	1.481	-	1.327	1.462	2.539	

X75	i <sub>n</sub>	XA 	XC 				XF 		
			B5 - B14				B5	B5 - B14	
			IEC 71	IEC 80	IEC 90	IEC 100-112	IEC 80	IEC 90	IEC 100-112
7.5	2.970	-	-	3.712	4.462	5.138	5.066	6.837	
10	2.492	-	-	3.234	3.984	4.661	4.588	6.359	
15	2.151	-	-	2.893	3.643	4.320	4.247	6.018	
20	1.567	-	-	2.774	3.523	3.735	3.662	5.433	
25	1.501	-	-	2.709	3.458	3.670	3.597	5.368	
30	1.946	1.615	1.575	2.689	3.438	4.115	4.042	5.813	
40	1.451	-	1.573	2.659	-	3.620	3.547	5.318	
50	1.435	-	1.570	2.642	-	3.603	3.531	5.302	
65	1.158	1.609	1.569	2.633	-	3.326	3.253	5.024	
80	1.153	1.605	1.565	2.629	-	3.322	3.249	5.020	
100	1.150	1.602	1.562	2.626	-	3.318	3.246	5.017	

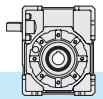

X89	i <sub>n</sub>		XC 		
			B5 - B14		
			IEC 80	IEC 90	IEC 100-112
7.5			6.898	7.671	
10			5.875	6.648	
15			5.144	5.917	
20			3.398	5.661	
25			3.256	5.520	
30			3.215	5.479	
40			3.151	-	
50			3.115	-	
65		2.024	3.096	-	
80		2.014	3.087	-	
100		2.008	3.080	-	









2.6 **Momenti d'inerzia** [Kg·cm<sup>2</sup>]  
(riferiti all'albero veloce in entrata)

2.6 **Moments of inertia** [Kg·cm<sup>2</sup>]  
(referred to input shaft)

2.6 **Моменты инерции** [кг см<sup>2</sup>]  
(относятся к быстроходному входному валу)

X90	$i_n$	XA 	XC 			XF 		
			B5 - B14			B5	B5 - B14	
			IEC 80	IEC 90	IEC 100-112	IEC 80	IEC 90	IEC 100-112
7.5	6.167			6.898	7.671	8.335	8.263	10.033
10	5.143		-	5.875	6.648	7.312	7.239	9.010
15	4.413		-	5.144	5.917	6.581	6.508	8.279
20	2.653		-	3.398	5.661	4.821	4.749	6.519
25	2.511		-	3.256	5.520	4.680	4.607	6.378
30	3.974		-	3.215	5.479	6.142	6.070	7.841
40	2.406		-	3.151	-	4.574	4.502	6.273
50	2.371		-	3.115	-	4.539	4.467	6.237
65	1.672		2.024	3.096	-	3.841	3.768	5.539
80	1.663		2.014	3.087	-	3.831	3.759	5.530
100	1.656		2.008	3.080	-	3.825	3.752	5.523

X110	$i_n$	XA 	XC 			XF 			
			B5 - B14			B5	B5 - B14		
			IEC 90	IEC 100-112	IEC 132	IEC 80	IEC 90	IEC 100-112	IEC 132
7.5	16.247		-	17.980	20.038	20.584	20.535	20.711	22.704
10	13.386		-	15.119	17.177	17.723	17.674	17.851	19.843
15	11.343		-	13.076	15.134	15.679	15.631	15.807	17.799
20	6.655		-	8.367	14.418	10.992	10.943	11.120	13.112
25	6.257		-	7.969	14.020	10.594	10.545	10.722	12.714
30	10.117		-	11.850	13.908	14.453	14.405	14.581	16.573
40	5.965		-	7.677	-	10.302	10.254	10.430	12.422
50	5.866		-	7.578	-	10.203	10.154	10.330	12.323
65	3.792		5.592	7.510	-	8.128	8.080	8.256	10.248
80	3.770		5.570	7.489	-	8.107	8.059	8.235	10.227
100	3.755		5.555	7.474	-	8.092	8.044	8.220	10.212

X130	$i_n$	XA 	XC 			XF 		
			B5 - B14			B5		
			IEC 90	IEC 100-112	IEC 132	IEC 90	IEC 100-112	IEC 132
7.5	42.80		-	40.70	42.78	48.92	49.22	50.01
10	35.06		-	32.96	35.04	41.18	41.48	42.27
15	29.53		-	27.43	29.51	35.66	35.96	36.74
20	18.95		-	16.68	27.58	25.07	25.37	26.16
25	17.80		-	15.52	26.42	23.92	24.22	25.00
30	26.22		-	24.12	26.20	32.34	32.64	33.42
40	17.09		-	14.81	25.71	23.21	23.51	24.29
50	16.80		-	12.57	-	22.92	23.22	24.00
65	12.53		10.46	14.35	-	18.66	18.96	19.74
80	12.48		10.41	14.30	-	18.60	18.90	19.68
100	12.44		10.37	14.26	-	18.56	18.86	19.65

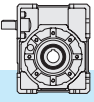

2.7 Dimensioni

2.7 Dimensions

2.7 Габаритные размеры

**XA**

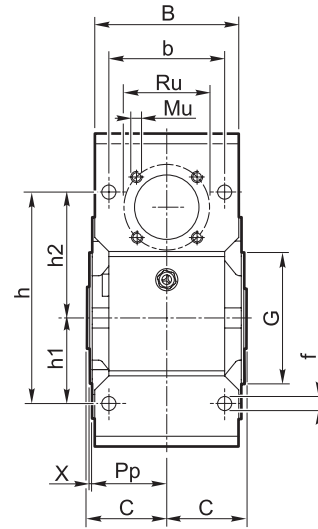
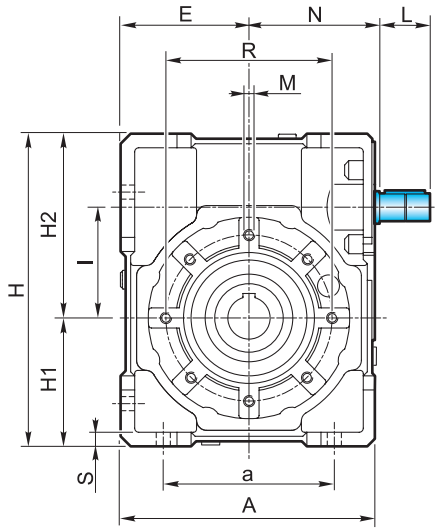

**XF**

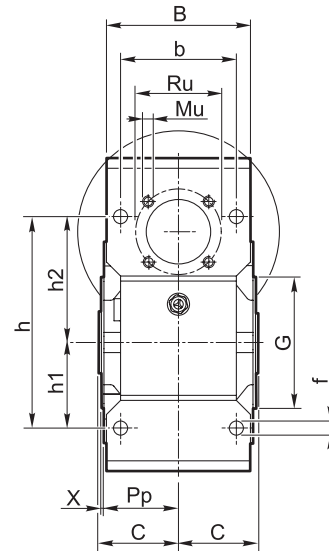
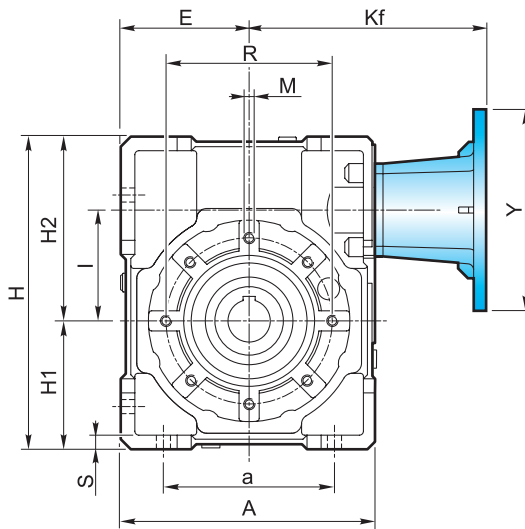

**XC**

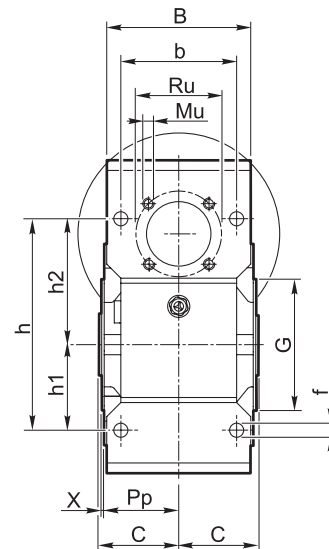
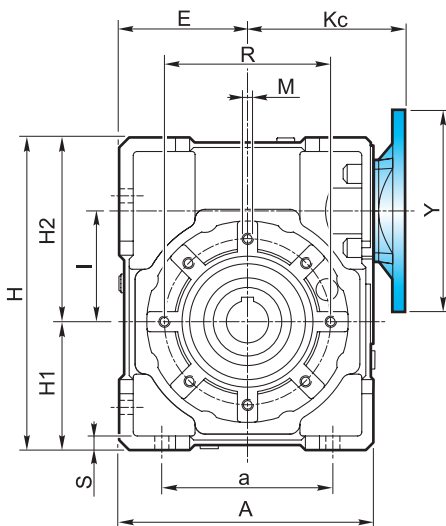

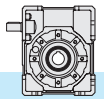

2.7 Dimensioni

2.7 Dimensions

2.7 Габаритные размеры

Flangia pendolare / Shaft-mounted flange / Устанавливаемый на вал фланец

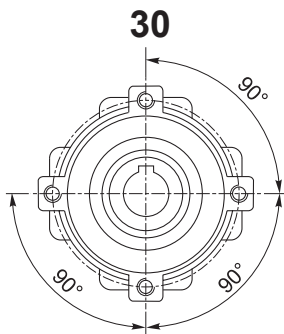

4 Fori / HoleОтверстия

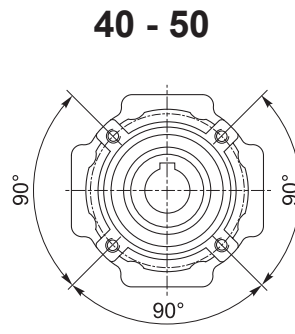

4 Fori / HoleОтверстия

63 - 75 - 89 - 90 - 110 - 130

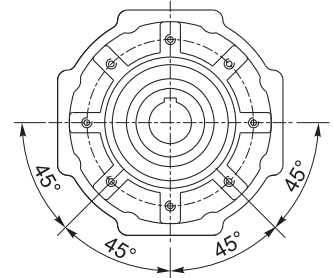

8 Fori / HoleОтверстия

Albero uscita cavo  
Output hollow shaft  
Выходной полый вал

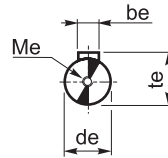
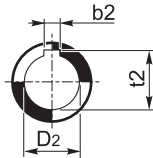

Albero entrata  
Input shaft  
Входной вал

X	A	a	B	b	b <sub>e</sub>	b <sub>2</sub>	C	d <sub>e</sub> j6	D <sub>2</sub> H8	E	f	G h8	H	H <sub>1</sub>	H <sub>2</sub>	h	h <sub>1</sub>	h <sub>2</sub>		
30	80	54	56	44	3	5	—	31.5	9	14	—	40	6.5	55	97	40	57	71	27	44
40	105	70	71	60	4	6	6	39	11	18	19	50	6.5	60	125	50	75	90	35	55
50	125	80	85	70	5	8	8	46	14	25	24	60	8.5	70	150	60	90	104	40	64
63	147	100	103	85	6	8	—	56	19	25	—	72	9	80	182	72	110	130	50	80
75	176	120	112	90	8	8	8	60	24	28	30	86	11	95	219.5	86	133.5	153	60	93
89*	203	140	130	100	—	10	10	70	—	35	32	103	13	110	248.5	103	145.5	172	70	102
90	203	140	130	100	8	10	10	70	24	35	32	103	13	110	248.5	103	145.5	172	70	102
110	252.5	170	143	115	8	12	—	77.5	28	42	—	127.5	14	130	310.5	127.5	183	210	85	125
130	292.5	200	155	120	10	14	14	85	38	45	48	147.5	15	180	355	147.5	207.5	240	100	140

X	I	K <sub>c</sub>	K <sub>f</sub>	L	M	M <sub>e</sub>	M <sub>u</sub>	N	P <sub>p</sub>	R	Ru	S	t <sub>e</sub>	t <sub>2</sub>	X	
30	31.5	57	vedi pag. see page см. стр. 36	15	M6x8	M4x10	M5x7.5	44.5	29	65	35.4	5.5	10.2	16.3	—	1.5
40	40	75		20	M6x10	M4x12	M5x10	57.5	36.5	75	42.4	6	12.5	20.8	21.8	1.5
50	50	82		25	M8x10	M5x13	M6x10	67.5	43.5	85	53.7	7	16	28.3	27.3	1.5
63	63	95		30	M8x14	M8x20	M6x12	77.5	53	95	60.8	8	21.5	28.3	—	2
75	75	112 - 110 <sup>(1)</sup>		40	M8x14	M8x20	M8x12	95	57	115	70.7	10	27	31.3	33.3	2
89*	90	122		—	M10x18	—	M8x14	—	67	130	70.7	12	—	38.3	35.3	2
90	90	122		40	M10x18	M8x20	M8x14	105	67	130	70.7	12	27	38.3	35.3	2
110	110	153		50	M10x18	M8x20	M10x18	130	74	165	85.0	14	31	45.3	—	2.5
130	130	173		70	M12x20	M10x25	M10x16	152	81	215	104	15	41	48.8	51.8	3

\*: 89 solo con tipo di entrata C

\*: 89 only with input type C

\* : 89 только с типом входа C

(1): Только для РАМ 71В14



2.7 Dimensioni

2.7 Dimensions

2.7 Габаритные размеры

Flangia uscita / Output flange / Выходной фланец

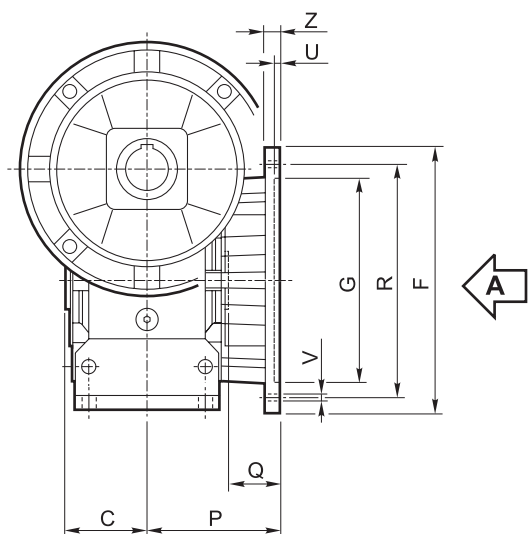

Vista da A / View from A / Вид с А

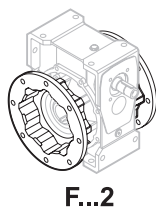
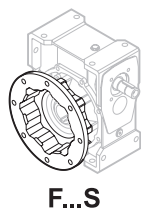
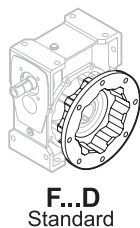
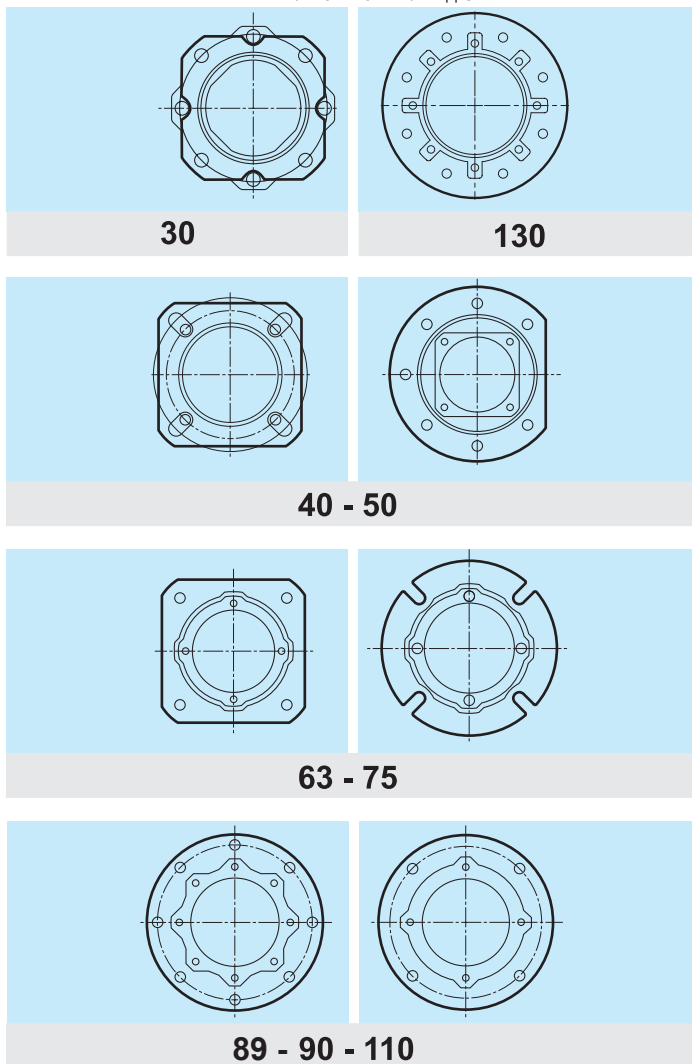

Tipo Type Тип	C	F		G H8	P	Q	R	U	V			Z
<b>30</b>	31.5		66	50	54.5	23	68	4	n° 4		6.5	6
<b>40</b>	39		85	60	67	28	75-90	4	n° 4		9	8
			85	60	97	58	75-90	4	n° 4		9	8
			140	95	80	41	115	5		n° 7	9	10
<b>50</b>	46		94	70	90	44	85-100	5	n° 4		11	10
			160	110	89	43	130	5		n° 7	11	11
<b>63</b>	56		142	115	82	26	150	5	n° 4		11	11
			142	115	112	56	150	5	n° 4		11	11
			160	110	80.5	24.5	130	5	n° 4		11	12
<b>75</b>	60		160	130	111	51	165	5	n° 4		13	12
			160	110	90	30	130	6	n° 4		11	13
<b>89 90</b>	70		200	152	111	41	175	5	n° 4		13	12
			200	152	151	81	175	5	n° 4		13	13
			200	130	110	40	165	6	n° 4		11	11
<b>110</b>	77.5		260	170	131	53.5	230	6		n° 8	13	15
			250	180	150	72.5	215	5	n° 4		15	16
<b>130</b>	85		320	180	140	55	255	7		n° 8 *	16	16
			300	230			265					

\* Foratura ruotata di 22.5°

\* Drilling turned of 22.5°

\* Отверстия повернуты на 22.5°





2.7 Dimensioni

2.7 Dimensions

2.7 Габаритные размеры

Flangia entrata / Input flange / Входной фланец

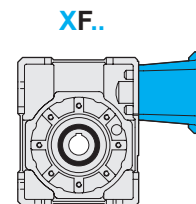
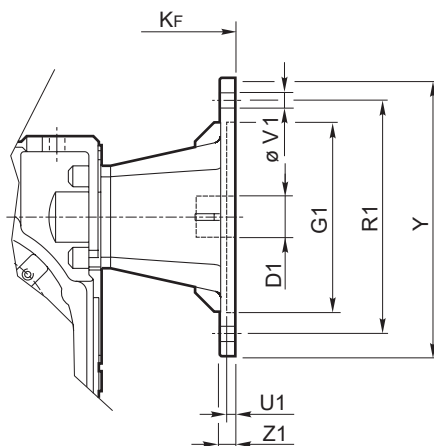
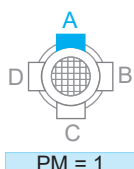

XF	IEC	PM		G <sub>1</sub>	K <sub>F</sub>	V <sub>1</sub>						Y	Z <sub>1</sub>
		1	2			R <sub>1</sub>	U <sub>1</sub>	Ø					
30	56 B5	•	•	80	82.5	100	3.5	7		8		120	8
	56 B14		•	50	82.5	65	3.5	6			4	80	8
	63 B5	•	•	95	85.5	115	4	9		8		140	10
	63 B14	•	•	60	85.5	75	3.5	6		8		90	8
40	56 B5	•	•	80	101.5	100	3.5	7		8		120	8
	63 B5	•	•	95	104.5	115	4	9		8		140	10
	63 B14	•	•	60	104.5	75	3.5	6		8		90	8
	71 B5	•	•	110	111.5	130	4.5	9		8		160	10
	71 B14	•	•	70	111.5	85	4	7		8		105	10
50	63 B5	•	•	95	119.5	115	4	9		8		140	10
	71 B5	•	•	110	126.5	130	4.5	9		8		160	10
	71 B14		•	70	126.5	85	3.5	7			4	105	10
	80 B5	•	•	130	136.5	165	4.5	11		8		200	10
	80 B14	•	•	80	136.5	100	4	7		8		120	10
63	71 B5	•	•	110	141.5	130	4.5	9		8		160	10
	80/90 B5	•	•	130	161.5	165	4.5	11		8		200	10
	80 B14	•	•	80	151.5	100	4	7		8		120	10
	90 B14	•	•	95	161.5	115	4	9		8		140	10
75	80/90 B5	•	•	130	190	165	4.5	11		8		200	10
	90 B14		•	95	190	115	4	9			4	140	10
	100/112 B5	•	•	180	200	215	5	14		8		250	14
	100/112 B14	•	•	110	200	130	4.5	9		8		160	10
90	80/90 B5	•	•	130	200	165	4.5	11		8		200	10
	90 B14		•	95	200	115	4	9			4	140	10
	100/112 B5	•	•	180	210	215	5	14		8		250	14
	100/112 B14	•	•	110	210	130	4.5	9		8		160	10
110	80/90 B5	•		130	235	165	4.5	11	4			200	12
	100/112 B5	•		180	245	215	5	14	4			250	14
	132 B5	•		230	266	265	5	14	4			300	16
	132 B14	•		130	266	165	4.5	11	4			200	12
130	90 B5	•		130	281	165	4.5	M10	4			200	12
	100/112 B5	•		180	289	215	5	13	4			250	16
	132 B5	•		230	310	265	5	13	4			300	20

N.B.: Il montaggio STD di P<sub>M</sub>=2 solo quando non è possibile il montaggio STD di P<sub>M</sub>=1.

N.B.: STD mounting of P<sub>M</sub>=2 only if STD mounting of P<sub>M</sub>=1 is not possible.

Примечание. Сборка STD P<sub>M</sub>=2, только когда невозможна сборка STD P<sub>M</sub>=1.

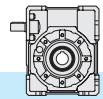

## 2.8 Entrata supplementare (vite bisporgente)

## 2.8 Additional input (double extended shaft)

## 2.8 Второй входной вал (двух концевой червячный вал)

S.e.A.

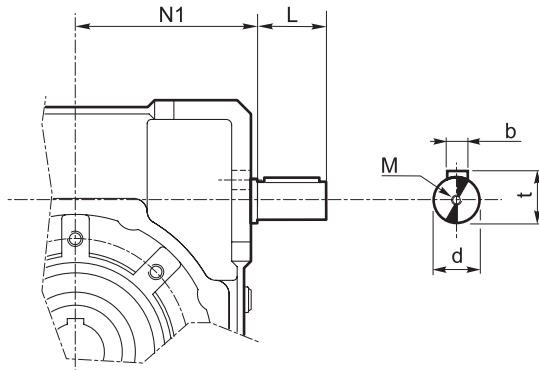

X	d j6	L	M	N1	b	t
30	9	15	M4x10	42.5	3	10.2
40	11	20	M4x12	52.5	4	12.5
50	14	25	M5x13	62.5	5	16
63	19	30	M8x20	74.5	6	21.5
75	24	40	M8x20	91	8	27
89 - 90	24	40	M8x20	108	8	27
110	28	50	M8x20	132.5	8	31
130	38	70	M10x25	152	10	41

## 2.9 Limitatore di coppia cavo passante

## 2.9 Torque limiter with through hollow shaft

## 2.9 Ограничитель момента вращения с полым сквозным валом

Il limitatore di coppia viene consigliato in tutte quelle applicazioni che richiedono una limitazione sulla coppia trasmissibile per proteggere l'impianto e/o preservare il riduttore evitando sovraccarichi o urti indesiderati quanto inaspettati.

È un dispositivo con albero dotato di cavo passante, con funzionamento a frizione, ed è integrato al riduttore, presentando un ingombro limitato.

Concepito per lavorare a bagno d'olio, il dispositivo risulta affidabile nel tempo ed è esente da usura se non viene mantenuto in condizioni prolungate di slittamento (condizione che si verifica quando la coppia presenta valori superiori a quelli di taratura).

La taratura è facilmente regolabile dall'esterno attraverso il serraggio di una ghiera autobloccante che porta a compressione le 4 molle a tazza disposte tra loro in serie.

Il dispositivo non consente:

- l'impiego di cuscinetti a rulli conici in uscita
- funzionamento prolungato in condizioni di slittamento.

Nella tabella seguente vengono riportati i valori delle coppie di slittamento  $M_{2S}$  in funzione del n° di giri della ghiera.

I valori di taratura presentano una tolleranza del  $\pm 10\%$  e si riferiscono ad una condizione statica.

In condizioni dinamiche è da notare che la coppia di slittamento assume valori diversi a seconda del tipo e/o modalità in cui si verifica il sovraccarico: con valori maggiori in caso di carico uniformemente crescente rispetto a valori più contenuti in seguito al verificarsi di picchi improvvisi di carico.

**NOTA:** quando si supera il valore di taratura si ha slittamento.

Il coefficiente di attrito tra le superfici di contatto da statico diventa dinamico e la coppia trasmessa cala del 30% circa.

E' quindi opportuno prevedere uno stop per poter ripartire al valore di taratura iniziale.

*The use of a torque limiter is advised when the application requires the limitation of the transmissible torque to safeguard the plant and/or to prevent from unexpected and undesired overloads or shocks which might damage the gearbox. The torque limiter is a device equipped with through hollow shaft and a friction clutch. It is integrated with the gearbox, therefore the space requirement is limited.*

*Designed to work in oil bath, the device is reliable over time and is not subject to wear unless kept under conditions of prolonged slipping (it occurs when the torque values are higher than the calibration values).*

*Calibration can be easily adjusted from outside by tightening the self-locking ring nut which causes the compression of the 4 Belleville washers arranged in series.*

*The device does not go together with:*

- the use of tapered roller bearings at output
- Prolonged operation under slipping conditions.

*The following table shows the values of  $M_{2S}$  slipping torques depending on the number of revolutions of the ring nut.*

*Calibration values feature a  $\pm 10\%$  tolerance and refer to static conditions.*

*Under dynamic conditions, the values of the slipping torque differ depending to the type of overload: the values are higher if the load increase is uniform, the values are lower if sudden load peaks occur.*

**NOTE:** *Slipping occurs when the setting values are exceeded.*

*The friction coefficient between the contact surfaces from static becomes dynamic and the transmitted torque is approx. 30% lower.*

*It is advisable to have a stop first in order to have a restart based on the initial setting value.*

Ограничитель крутящего момента рекомендуется во всех случаях, когда требуется ограничение передаваемого крутящего момента для защиты системы и / или редуктора от перегрузок или нежелательных и непредвиденных ударов.

Это устройство с полым сквозным валом фрикционного действия, встроенное в редуктор и имеющее ограниченные габаритные размеры.

Предназначенное для работы в масляной ванне, это устройство имеет большой ресурс и устойчиво к износу, если не находится в условиях длительного пробуксовывания (состояние, которое возникает, когда значение крутящего момента выше калибровочного).

Тарирование легко регулируется снаружи посредством затягивания самоблокирующейся кольцевой гайки, которая сжимает 4 тарельчатые пружины, расположенные последовательно друг за другом.

Устройство не позволяет:

- использование конических роликовых подшипников на выходе
- длительная работа в условиях пробуксовывания.

В следующей таблице приводятся значения момента пробуксовывания  $M_{2S}$  в зависимости от количества оборотов зажимного кольца.

Значения тарирования имеют допуск  $\pm 10\%$  и относятся к статическому состоянию.

В динамических условиях следует отметить, что момент пробуксовывания принимает разные значения в зависимости от типа и / или режима, в котором возникает перегрузка: более высокие значения при равномерно увеличивающейся нагрузке по сравнению с более умеренными значениями после возникновения внезапных пиков нагрузки.

**ПРИМЕЧАНИЕ:** Когда превышает значение тарирования, происходит пробуксовывание.

Коэффициент трения между контактирующими поверхностями от статического становится динамическим и передаваемый момент вращения понижается приблизительно на 30%.

Поэтому необходимо предусмотреть остановку, чтобы возобновить работу на начальном заданном значении.





E' importante notare che la coppia di slittamento non resta sempre la medesima durante tutta la vita del limitatore.

Tende infatti a diminuire in rapporto al numero e alla durata degli slittamenti che, rodando le superfici di contatto, ne aumentano il rendimento.

È quindi opportuno verificare periodicamente, soprattutto durante la fase di rodaggio, la taratura del dispositivo.

Là dove sia richiesto un errore più contenuto nella taratura, è necessario testare la coppia trasmissibile sull' impianto.

Il dispositivo viene consegnato tarato alla coppia riportata a catalogo T<sub>2M</sub> salvo diversa indicazione espressa in fase di ordinazione.

*It is important to note that the slipping torque is not the same for the entire life of the torque limiter. It usually decreases in connection with the number and the duration of slippings, this is due to the surface of the torque limiter becoming more engaged, therefore increasing the efficiency. For this reason it is advisable to check the calibration of the device at regular intervals, specially during the running-in period. Should a smaller calibration error be required, it is necessary to test the transmissible torque on the plant.*

*The torque limiter is supplied already calibrated at the torque value T<sub>2M</sub>, unless otherwise specified in the order.*

Важно отметить, что момент пробуксовывания остаётся одинаковым в течении всего срока эксплуатации ограничителя.

Фактически он имеет тенденцию к снижению в зависимости от количества и продолжительности пробуксовываний, которые, при обкатке контактных поверхностей, увеличивают производительность.

Поэтому важно периодически проверять, прежде всего, во время обкатки, тарирование устройства.

Если следует сократить ошибку при тарировании, необходимо тестировать крутящий момент, передаваемый на установку.

Устройство поставляется тарированным на момент вращения, приведённый в каталоге T2M при отсутствии других указаний при заказе.

X	N°. giri della ghiera di regolazione / N°. revolutions of ring nut / Кол. оборотов кольцевой гайки настройки															
	3/4	1	1 1/4	1 1/2	1 3/4	2	2 1/4	2 1/2	2 3/4	3	3 1/4	3 1/2	3 3/4	4	4 1/4	4 1/2
	M <sub>2S</sub> [Nm]															
30		15	18	22	27	32										
40	23	30	35	40	45	50	60									
50		45	60	70	80	90	100	110								
63			80	90	100	110	120	130	140	150	160	170	180	190	200	
75		140	160	180	200	220	240	260	280	300						
89 - 90						230	280	310	330	350	380	410	435	460	490	510
110		420	500	560	670	730	810	910								
130																

Disposizione delle molle  
Washers' arrangement  
Расположение пружин

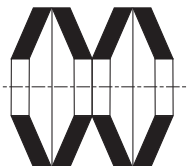

**IN SERIE** (min. coppia, max. sensibilità)  
**SERIES** (min. torque, max sensitivity)  
**SERIE ПОСЛЕДОВАТЕЛЬНОЕ** (мин. момент вращения, макс. чувствительность)

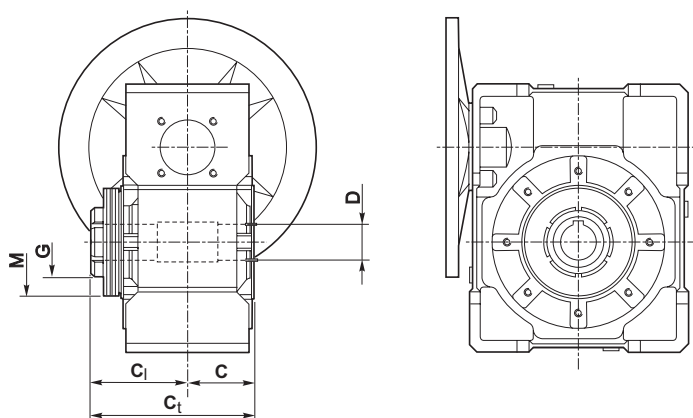

X	C	C <sub>1</sub>	C <sub>2</sub>	D <sub>H8</sub>	M	G
30	31.5	55.5	87	14	50x25.4x1.25	M25x1.5
40	39	65	104	18 (19)	56x30.5x1.5	M30x1.5
50	46	76	122	25 (24)	63x40.5x1.8	M40x1.5
63	56	91	147	25	71x40.5x2	M40x1.5
75	60	100	160	28 (30)	90x50.5x2.5	M50x1.5
89 - 90	70	109	179	35 (32)	100x51x2.7	M50x1.5
110	77.5	127.5	205	42	125x61x4	M60x2.0
130						

( ) A richiesta / On request / По заявке

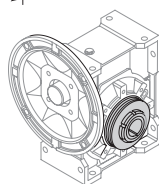

LD

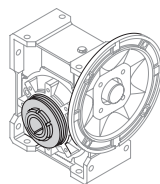

LS

Nella versione con limitatore non è prevista la fornitura degli alberi lenti.

*The version with torque limiter is supplied without output shafts.*

В версии с ограничителем не предусмотрена поставка цельных выходных валов.

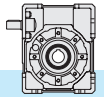

2.10 Accessori

2.10 Accessories

2.10 Комплектующие

Albero lento

Output shaft

Цельный выходной вал

Albero lento semplice  
Single output shaft  
Односторонний выходной вал

Albero lento doppio  
Double output shaft  
Двухсторонний выходной вал

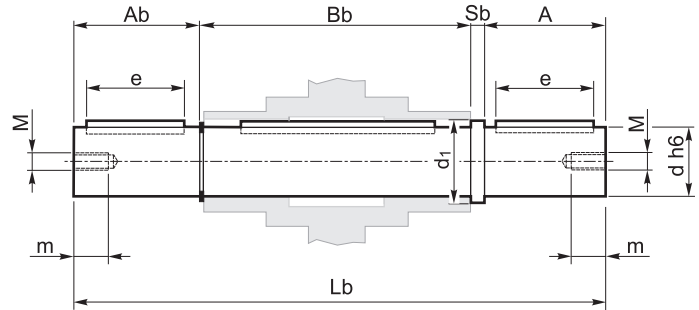
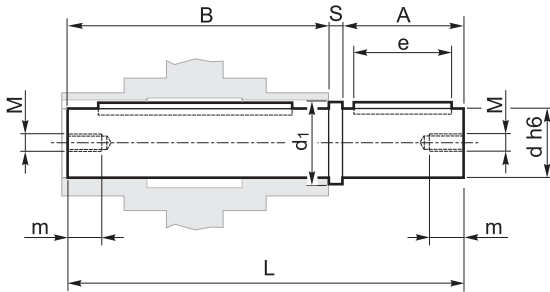

X	A	B	d <sub>h6</sub>		d <sub>1</sub>	e	L	M	m	S
30	30	62	14		18.5	20	94.5	M6	16	2.5
40	40	77	18	19	23.5	30	120	M6	16	3
50	50	90	25	24	31.5	40	143.5	M8	22	3.5
63	50	111	25		31.5	40	165	M8	22	4
75	60	119	28	30	34.5	50	183	M8	22	4
89 - 90	80	139	35		41.5	60	224	M10	28	5
110	80	154.5	42		49.5	60	242.5	M10	28	8
130	80	168	45		54.5	70	253	M16	36	5

A	A <sub>b</sub>	B <sub>b</sub>	d <sub>h6</sub>	d <sub>1</sub>	e	L <sub>b</sub>	S <sub>b</sub>
30	29	64	14	18.5	20	126	2.5
40	39	79	18	23.5	30	161	3
50	49	93	25	31.5	40	195.5	3.5
50	49	113	25	31.5	40	216	4
60	59	121	28	34.5	50	244	4
80	78.5	141.5	35	41.5	60	305	5
80	77.5	157	42	49.5	60	322.5	8
80	78	172	45	54.5	70	335	5

Braccio di reazione

Torque arm

Моментный рычаг

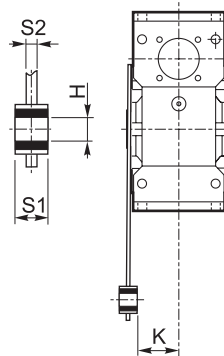
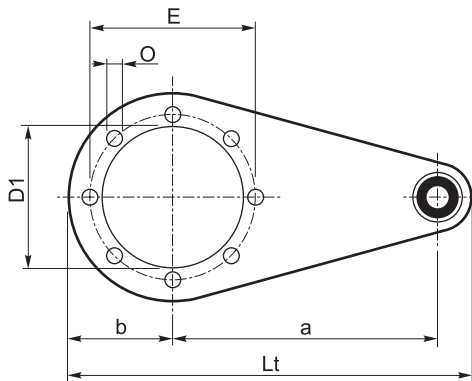

X	a	b	D <sub>1</sub>	E	H	K	L <sub>t</sub>	O	S <sub>1</sub>	S <sub>2</sub>
30	85	37.5	55	65	8	24	141.5	7	14	4
40	100	45	60	75	10	31.5	167	7	14	4
50	100	50	70	85	10	39	172	9	14	5
63	150	55	80	95	10	49	227	9	14	6
75	200	70	95	115	20	47.5	302	9	25	6
89 - 90	200	80	110	130	20	57.5	312	11	25	6
110	250	100	130	165	25	62	390	11	30	6
130	250	125	180	215	25	69	415	13	30	6

Kit di protezione:

Protection Kit:

Предохранительный комплект:

Albero cavo / Hollow shaft / Полюый вал

Limitatore di coppia / Torque limiter / Ограничитель момента вращения

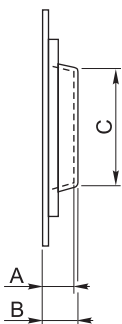

X	A	B	C
30	12	13	39
40	14	15.5	44.5
50	15	16.5	54
63	17	19	60
75	17.5	20	70
89 - 90	21.5	24	80
110	22	25	96
130	22	25	130

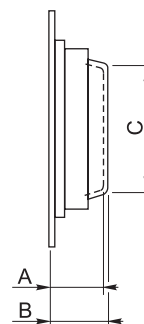

X	A	B	C
30	36	37	36
40	40	41.5	44
50	47	48.5	53
63	52	54	55
75	58	60	68
89 - 90	60.5	63	70
110	72	75	85
130			

Opzioni disponibili:

Available options:

Доступные опции:

Cuscinetti a rulli conici corona

Tapered roller bearing on wormgear

Подшипник с коническими роликами венца



## XA - XF

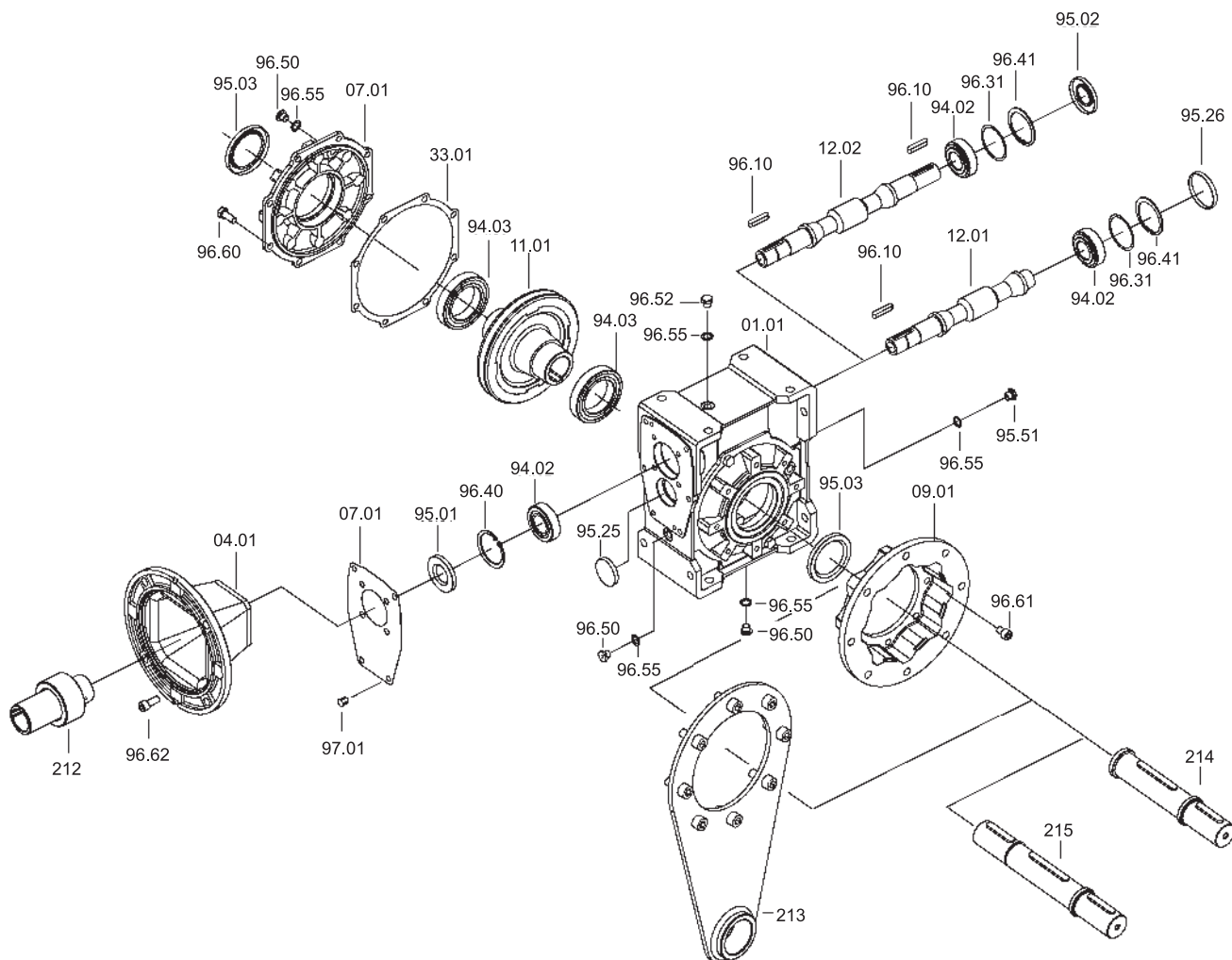

X	Cuscinetti / Bearings / Подшипники			Anelli di tenuta / Oilseals / Сальники			Cappellotto / Closed oil seal / Сальниковая крышка	
	94.02	94.03		95.01	95.02	95.03	95.25	95.26
<b>30</b>	<b>6000</b> 10x26x8	<b>6005</b> 25x47x12	<b>*32005</b> 25x47x15	10/26/5.5	10/26/7	25/40/7	—	ø 6x7
<b>40</b>	<b>6201</b> 12x32x10	<b>6006</b> 30x55x13	<b>*32006</b> 30x55x17	12/32/7	12/32/7	30/47/7	—	ø 32x7
<b>50</b>	<b>6203</b> 17x40x12	<b>6008</b> 40x68x15	<b>*32008</b> 40x68x19	17/40/7	17/40/7	40/62/8	—	ø 40x7
<b>63</b>	<b>30204</b> 20x47x15.25	<b>6008</b> 40x68x15	<b>*32008</b> 40x68x19	20/47/7	20/47/7	40/62/8	—	ø 47x7
<b>75</b>	<b>30205</b> 25x52x16.25	<b>6010</b> 50x80x16	<b>*32010</b> 50x80x20	25/52/7	25/52/7	50/72/8	—	ø 52x7
<b>90</b>	<b>32205</b> 25x52x19.25	<b>6010</b> 50x80x16	<b>*32010</b> 50x80x20	25/52/7	25/52/7	50/72/8	ø 35x5	ø 52x7
<b>110</b>	<b>32206B</b> 30x62x21.25	<b>6012</b> 60x95x18	<b>*32012</b> 60x95x23	30/62/7	30/62/7	60/85/8	ø 47x7	ø 62x7
<b>130</b>	<b>33208</b> 40x80x32	<b>6015</b> 75x115x20	<b>*32015</b> 75x115x25	40/80/10	40/80/10	75/100/10	ø 52x7	ø 80x10

\* Cuscinetti a rulli conici a richiesta - Tapered roller bearings on request - Подшипник с коническими роликами по заявке

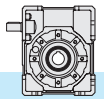

# XC

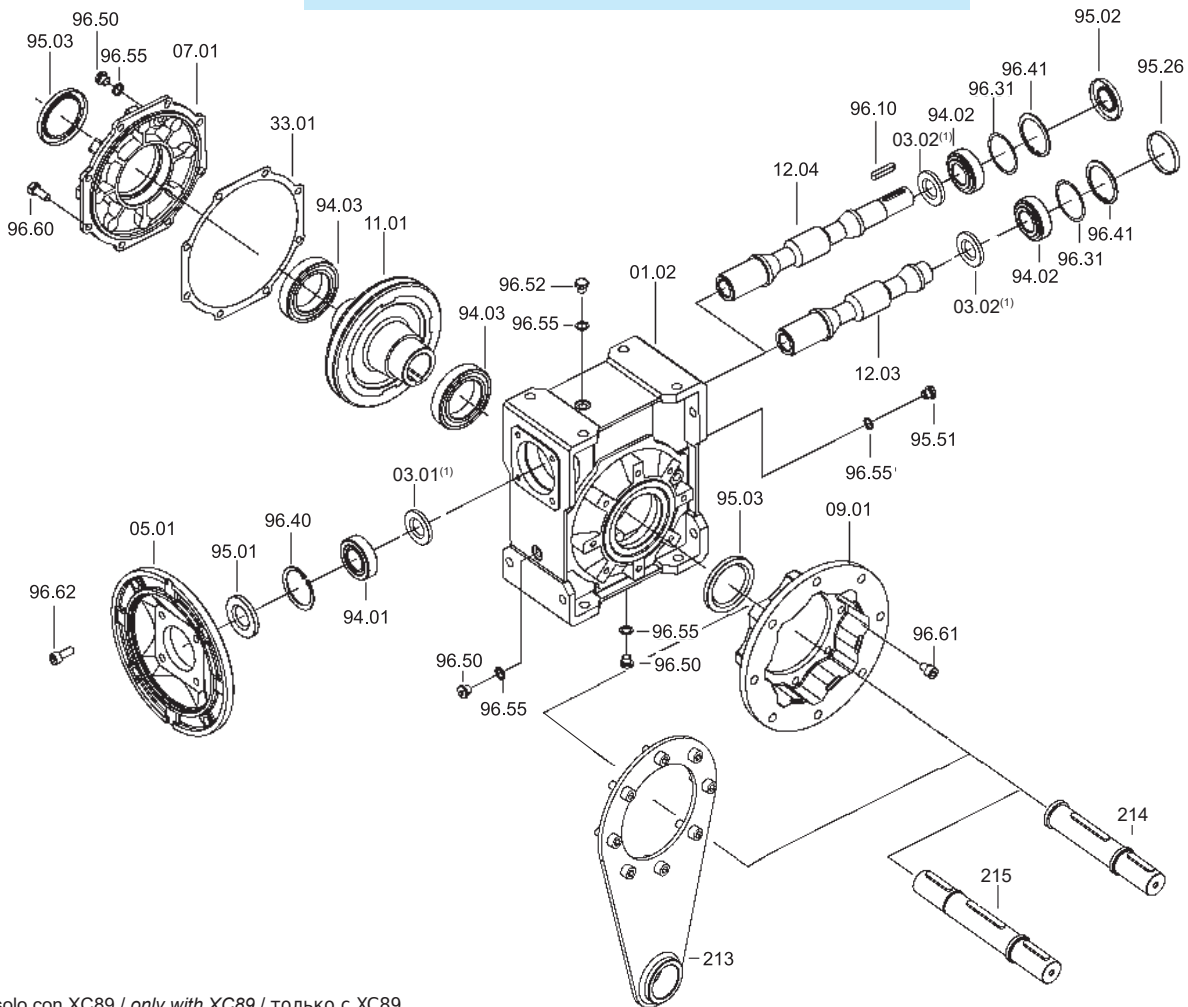

(1): solo con XC89 / only with XC89 / только с XC89

X	IEC	Cuscinetti / Bearings / Подшипники			Anelli di tenuta / Oilseals / Сальники			Cappello / Closed oil seal / Сальниковая крышка	
		94.01	94.02	94.03	95.01	95.02	95.03	95.26	
30	56	61804 (20x32x7)	6000 10x26x8	6005 25x47x12	*32005 25x47x15	20/32/5 20/32/5	10/26/7	25/40/7	ø 26x7
	63	61804 (20x32x7)							
40	56	6303 (17x47x14)	6201 12x32x10	6006 30x55x13	*32006 30x55x17	17/47/7	12/32/7	30/47/7	ø 32x7
	63	6204 (20x47x14)				20/47/7			
	71	6005 (25x47x12)	25/47/7						
50	63	6204 (20x47x14)	6203 17x40x12	6008 40x68x15	*32008 40x68x19	20/47/7	17/40/7	40/62/8	ø 40x7
	71	6005 (25x47x12)				25/47/7			
	80	6006 (30x55x13)	30/55/7						
63	71	30305 (25x62x18.25)	30204 20x47x15.25	6008 40x68x15	*32008 40x68x19	25/62/7	20/47/7	40/62/8	ø 47x7
	80	30206 (30x62x17.25)				30/62/7			
	90	32007 (35x62x18)				35/62/7			
75	71	30206 (30x62x17.25)	30205 25x52x16.25	6010 50x80x16	*32010 50x80x20	30/62/7	25/52/7	50/72/8	ø 52x7
	80	30206 (30x62x17.25)				30/62/7			
	90	32007 (35x62x18)				35/62/7			
	100/112	32008 (40x68x19)				40/68/10			
89	80	6206 (30x62x16)	6205 C3 25x52x15	6010 50x80x16	*32010 50x80x20	30/62/7	25/52/7	50/72/8	ø 52x7
	90	6007 (35x62x14)				35/62/7			
	100/112	6008 (40x68x15)				40/68/10			
90	80	30206 (30x62x17.25)	32205B 25x52x19.25	6010 50x80x16	*32010 50x80x20	30/62/7	25/52/7	50/72/8	ø 52x7
	90	32007 (35x62x18)				35/62/7			
	100/112	32008 (40x68x19)				40/68/10			
110	90	30208 (40x80x19.75)	32206B 30x62x21.25	6012 60x95x18	*32012 60x95x23	40/80/10	30/62/7	60/85/8	ø 62x7
	100/112	30208 (40x80x19.75)				40/80/10			
	132	32010 (50x80x20)				50/80/10			
130	90	30208 (40x80x19.75)	33208 40x80x32	6015 75x115x20	*32015 75x115x25	40/80/10	40/80/10	75/100/10	ø 80x10
	100/112	30208 (40x80x19.75)				40/80/10			
	132	32010 (50x80x20)				50/80/10			

\* Cuscinetti a rulli conici a richiesta - Tapered roller bearings on request - \* Подшипник с коническими роликами по заявке

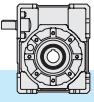

GAMME DI PRODOTTO  
RANGE OF PRODUCTS

Riduttori a vite senza fine / Worm gearboxes  
Riduttori a ingranaggi / Helical and bevel helical gearboxes  
Riduttori epicicloidali di precisione / Precision planetary gearboxes  
Riduttori speciali / Special gearboxes  
Variatori di velocità / Mechanical variators

