



RFV

RIDUTTORI PENDOLARI

SHAFT-MOUNTED
GEARBOXES

AUFSTECKGETRIEBE

RÉDUCTEURS PENDULAIRES

REDUCTORES PENDULARES

REDUCTORES PENDULARES

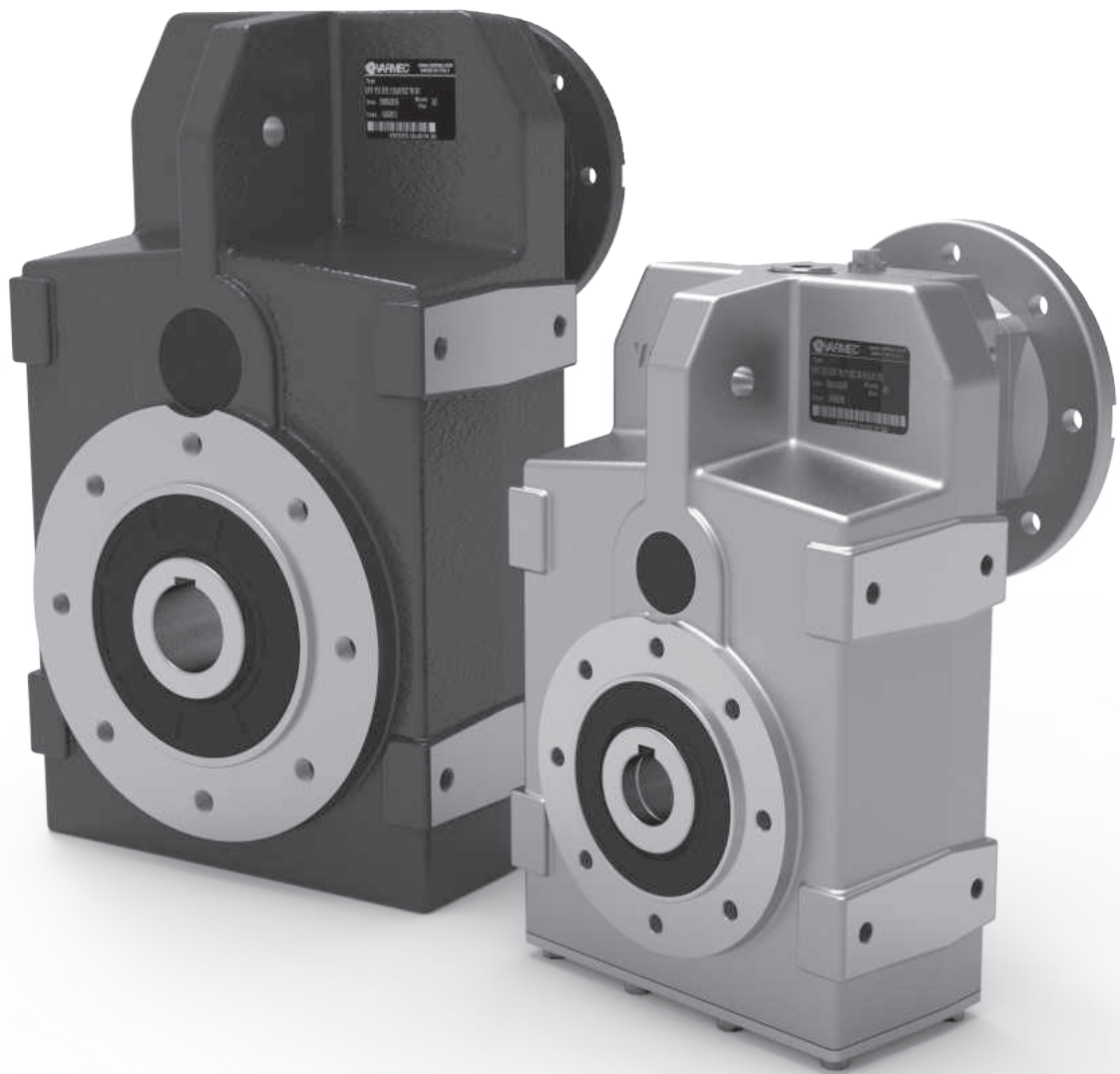

RFV

Riduttori pendolari
Shaft-mounted gearboxes
Aufsteckgetriebe
Réducteurs pendulaires
Reductores pendulares
Redutores pendulares





IT

EN

DE



1	SIMBOLOGIA E UNITA' DI MISURA	SYMBOLS AND UNITS OF MEASURE	SYMBOLE UND MAßEINHEITEN	4
2	INFORMAZIONI GENERALI	GENERAL INFORMATION	ALLGEMEINE INFORMATIONEN	6
3	FATTORE DI SERVIZIO FS	SERVICE FACTOR FS	BETRIEBSFAKTOR FS	8
4	POTENZA TERMICA	THERMAL POWER	THERMISCHE LEISTUNG	10
5	SELEZIONE	SELECTION	AUSWAHL	12
6	VERIFICHE	CHECK	ÜBERPRÜFUNGEN	14
7	INSTALLAZIONE	INSTALLATION	INSTALLATION	14
8	ISTRUZIONI PER IL SERRAGGIO DEL CALETTATORE	INSTRUCTIONS FOR FITTING THE SHRINK DISC	ANLEITUNGEN FÜR DEN ANZUG DER SCHRUMPFSCHEIBE	18
9	MANUTENZIONE	MAINTENANCE	WARTUNG	20
10	STOCCAGGIO	STORAGE	LAGERUNG	20
11	CONDIZIONI DI FORNITURA	CONDITIONS OF SUPPLY	LIEFERBEDINGUNGEN	22
12	CARATTERISTICHE COSTRUTTIVE	CONSTRUCTION FEATURES	BAUMERKMALE	24
13	FORME COSTRUTTIVE	CONSTRUCTION SHAPES	BAUFORMEN	24
14	DESIGNAZIONE	DESIGNATION	BEZEICHNUNG	26
15	LUBRIFICAZIONE	LUBRICATION	SCHMIERUNG	28
16	QUANTITÀ DI LUBRIFICANTE	QUANTITY OF LUBRICANT	SCHEMIERMITTELMENGE	30
17	POSIZIONI DI MONTAGGIO	ASSEMBLY POSITIONS	MONTAGEPOSITIONEN	31
18	CARICHI RADIALI E ASSIALI	RADIAL AND AXIAL LOADS	RADIAL UND AXIALLASTEN	36
19	DATI TECNICI MOTORIDUTTORI	MOTOR REDUCER TECHNICAL DATA	TECHNISCHE DATEN DER GETRIEBEMOTOREN	41
20	FLANGIA ENTRATA	INPUT FLANGE	ANTRIEBSFLANSCH	65
21	DATI TECNICI RIDUTTORI	REDUCER TECHNICAL DATA	TECHNISCHE DATEN GETRIEBE	67-87
22	DIMENSIONI	DIMENSIONS	ABMESSUNGEN	68-87
23	ACCESSORI	ACCESSORIES	ZUBEHÖR	88
24	ATEX 	ATEX 	ATEX 	92
25	PARTI DI RICAMBIO	SPARE PARTS LIST	ERSATZTEILLISTE	94
26	MOTORI ELETTRICI	ELECTRIC MOTORS	ELEKTROMOTOREN	104



FR	ES	PT		
SYMBOLOGIE ET UNITÉ DE MESURE	SIMBOLOGIA Y UNIDADES DE MEDIDA	SIMBOLOGIA E UNIDADES DE MEDIDA	5	1
INFORMATIONS GÉNÉRALES	INFORMACIÓN GENERAL	INFORMAÇÕES GERAIS	7	2
FACTEUR DE SERVICE FS	FACTOR DE SERVICIO FS	FATOR DE SERVIÇO FS	9	3
PUISSANCE THERMIQUE	POTENCIA TÉRMICA	POTÊNCIA TERMICA	11	4
SÉLECTION	SELECCIÓN	SELEÇÃO	13	5
VÉRIFICATIONS	VERIFICACIONES	VERIFICAÇÕES	15	6
INSTALLATION	INSTALACIÓN	INSTALAÇÃO	15	7
INSTRUCTIONS POUR LE SERRAGE DE LA FRETTE	INSTRUCCIONES PARA EL APRIETE DEL ENSAMBLAJE	INSTRUÇÕES PARA O APERTO DO DISCO DE CONTRAÇÃO	19	8
ENTRETIEN	MANTENIMIENTO	MANUTENÇÃO	21	9
STOCKAGE	ALMACENAMIENTO	STOCCAGGIO	21	10
CONDITIONS DE FOURNITURE	CONDICIONES DE SUMINISTRO	CONDIÇÕES DE FORNECIMENTO	23	11
CARACTÉRISTIQUES DE CONSTRUCTION	CARACTERÍSTICAS DE FABRICACIÓN	CARACTERÍSTICAS CONSTRUTIVAS	25	12
FORMES DE CONSTRUCTION	FORMAS DE FABRICACIÓN	FORMAS CONSTRUTIVAS	25	13
DÉSIGNATION	DESIGNACIÓN	DESIGNAÇÃO	26	14
LUBRIFICATION	LUBRICACIÓN	LUBRIFICAÇÃO	29	15
QUANTITÉ DE LUBRIFIANT	CANTIDAD DE LUBRICANTE	QUANTIDADE DE LUBRIFICANTE	30	16
POSITIONS DE MONTAGE	POSICIONES DE MONTAJE	POSIÇÕES DE MONTAGEM	31	17
CHARGES RADIALES ET AXIALES	CARGAS RADIALES Y AXIALES	CARGUE RADIALS E AXIALS	37	18
CARACTÉRISTIQUES TECHNIQUES MOTO-REDUCTEURS	DATOS TÉCNICOS MOTORREDUCTORES	CARACTERÍSTICAS TÉCNICAS MOTORIDUTOR	41	19
BRIDE D'ENTRÉE	BRIDA ENTRADA	FLANGE DE ENTRADA	65	20
CARACTÉRISTIQUES TECHNIQUES REDUCTEURS	DATOS TÉCNICOS REDUCTORES	CARACTERÍSTICAS TÉCNICAS RIDUTOR	67-87	21
DIMENSIONS	DIMENSIONES	DIMENSÕES	68-87	22
ACCESSOIRES	ACCESORIOS	ACESSÓRIOS	88	23
ATEX 	ATEX 	ATEX 	92	24
LISTE DES PIÈCES DÉTACHÉES	LISTA DE RECAMBIOS	LISTA DE RECAMBIOS	94	25
MOTEURS ÉLECTRIQUES	MOTORES ELÉTRICOS	MOTORES ELECTRICOS	104	26



Simbologia e unità di misura / Symbols and units of measure / Symbole und Maßeinheiten

1

Simb. Symb.	U.M.	Descrizione	Description	Beschreibung
C	—	Fattore di sollecitazione a carico radiale	<i>Radial load stress factor</i>	Belastungsfaktor Radialkraft
fs	—	Fattore di servizio	<i>Service factor</i>	Betriebsfaktor
ft	—	Fattore moltiplicativo	<i>Multiplying factor</i>	Multiplikation Faktors
Fa ₁	[N]	Carico assiale massimo ammissibile sull'albero veloce	<i>Maximum permissible thrust load on input shaft</i>	Max. zul. Axialkraft an Eintriebswelle
Fa ₂	[N]	Carico assiale massimo ammissibile sull'albero lento	<i>Maximum permissible thrust load on output shaft</i>	Max. zul. Axialkraft an Abtriebswelle
Fr ₁	[N]	Carico radiale massimo ammissibile sull'albero veloce	<i>Maximum permissible radial load on input shaft</i>	Max. zul. Radialkraft an Eintriebswelle
Fr ₂	[N]	Carico radiale massimo ammissibile sull'albero lento	<i>Maximum permissible radial load on output shaft</i>	Max. zul. Radialkraft an Abtriebswelle
Fr _c	[N]	Carico radiale di calcolo	<i>Calculated radial load</i>	Geschätzte Radiallast
Fr _{x1}	[N]	Carico radiale massimo ammissibile sull'albero veloce ricalcolato rispetto ad una distanza x dalla battuta dell'albero	<i>Maximum permissible radial load on input shaft recalculated with respect to different load application points</i>	Max. zul. Radialkraft an Eintriebswelle unter Berücksichtigung verschiedener Belastungen der Eintriebswelle
Fr _{x2}	[N]	Carico radiale massimo ammissibile sull'albero lento ricalcolato rispetto ad una distanza x dalla battuta dell'albero	<i>Maximum permissible radial load on output shaft recalculated with respect to different load application points</i>	Max. zul. Radialkraft an Abtriebswelle unter Berücksichtigung verschiedener Belastungen der Abtriebswelle
i	—	Rapporto di riduzione	<i>Reduction ratio</i>	Untersetzung
l	[%]	Grado di intermittenza	<i>Degree of intermittence</i>	Relative Einschaldauer
Jm	[Kg·m ²]	Momento d'inerzia del motore elettrico	<i>Motor moment of inertia</i>	Massenträgheitsmoment Elektromotor
Jr	[Kg·m ²]	Momento d'inerzia Riduttore	<i>Gear reducer moment of inertia</i>	Trägheitsmoment / Getriebe
Ju	[Kg·m ²]	Momento d'inerzia delle masse esterne	<i>Moment of inertia of external masses</i>	Massenträgheitsmoment der angetriebenen Massen
K	—	Fattore di accelerazione delle masse	<i>Acceleration factor of masses</i>	Belastungsfaktor
M ₁	[Nm]	Momento torcente in entrata riduttore	<i>Transmitted torque at gear reducer entrance</i>	Effettivo Eintriebsdrehmoment
M ₂	[Nm]	Momento torcente in uscita riduttore	<i>Transmitted torque at gear reducer exit</i>	Effektives Abtriebsdrehmoment
Mn ₂	[Nm]	Momento torcente nominale in uscita riduttore	<i>Gear reducer rated output torque</i>	Max. Abtriebsdrehmoment
Mr ₂	[Nm]	Momento torcente richiesto in uscita riduttore	<i>Required torque at gear reducer output</i>	Benötigtes Abtriebsdrehmoment
Mc ₂	[Nm]	Momento torcente di calcolo in uscita riduttore	<i>Calculated torque at gear reducer output</i>	Berechnetes Abtriebsdrehmoment
n ₁	[min ⁻¹]	Velocità angolare in entrata riduttore	<i>Angular speed at gear reducer input</i>	Eintriebsdrehzahl
n ₂	[min ⁻¹]	Velocità angolare in uscita riduttore	<i>Angular speed at gear reducer output</i>	Abtriebsdrehzahl
P ₁	[kW]	Potenza in entrata riduttore	<i>Transmitted power at gear reducer input</i>	Eintriebsleistung
P ₂	[kW]	Potenza in uscita riduttore	<i>Transmitted power at gear reducer output</i>	Abtriebsleistung
Pm	[kW]	Potenza nominale motore elettrico	<i>Motor rated power</i>	Motorleistung
Pn ₁	[kW]	Potenza nominale in entrata riduttore	<i>Gear reducer rated input power</i>	Max. Eintriebsleistung
Pn ₂	[kW]	Potenza nominale in uscita riduttore	<i>Gear reducer rated output power</i>	Max. Abtriebsleistung
Pr ₁	[kW]	Potenza richiesta in entrata riduttore	<i>Required input power</i>	Benötigte Eintriebsleistung
Pt	[kW]	Potenza termica	<i>Thermic power</i>	Thermische Leistung
Rd		Rendimento dinamico	<i>Dynamic efficiency</i>	Dynamischer Wirkungsgrad
ta	[°C]	Temperatura ambiente	<i>Ambient temperature</i>	Umgebungstemperatur
tf	[min]	Tempo di funzionamento a carico costante	<i>Operating time with constant load</i>	Betriebszeit mit Dauerlast
tf	[min]	Tempo di riposo	<i>Rest time</i>	Aussetzzeit
		Rimando a pagina	<i>Refer to page</i>	Siehe Seite



Symbologie et unité de mesure / Simbología y unidades de medida / Simbologia e unidades de medida

1

Simb. Symb.	U.M.	Description	Descripción	Descrição
C	—	Facteur d'application de la charge radiale	<i>Factor de sollicitación a carga radial</i>	Fatore de silitação a carga radial
fs	—	Facteur de service	<i>Factor de servicio</i>	Fatore de serviço
ft	—	Facteur de multiplication	<i>Factor de multiplicación</i>	Fator multiplicativo
Fa ₁	[N]	Charge axiale maxi admissible sur l'arbre d'entrée	<i>Carga axial máxima admisible en el eje de entrada</i>	Carga empuxo maximo a colocar sobre eixo veloz
Fa ₂	[N]	Charge axiale maxi admissible sur l'arbre de sortie	<i>Carga axial máxima admisible en el eje de salida</i>	Carga empuxo maximo a colocar sobre eixo lento
Fr ₁	[N]	Charge radiale maxi admissible sur l'arbre d'entrée	<i>Carga radial máxima admisible en el eje de entrada</i>	Carga radial maximo a colocar sobre eixo veloz
Fr ₂	[N]	Charge radiale maxi admissible sur l'arbre de sortie	<i>Carga radial máxima admisible en el eje de salida</i>	Carga radial maximo a colocar sobre eixo lento
Fr _c	[N]	Charge radiale calculée	<i>Carga radial calculada</i>	Carga radial de cálculo
Fr _{x1}	[N]	Charge radiale maxi admissible sur l'arbre d'entrée après application de facteurs de correction	<i>Carga radial máxima admisible sobre el eje de entrada recalculado respecto a otra distancia del punto de aplicación de la carga del rebaje del eje.</i>	carga radial maximo a colocar sobre o' eixo veloz calculado respeto a uma distancia da batida do eixo
Fr _{x2}	[N]	Charge radiale maxi admissible sur l'arbre de sortie après application de facteurs de correction	<i>Carga radial máxima admisible sobre el eje de salida recalculado respecto a otra distancia del punto de aplicación de la carga del rebaje del eje.</i>	Carga radial máximo a colocar sobre eixo lento calculado respeto a uma distancia da batida do eixo
i	—	Rapport de réduction	<i>Relación de reducción</i>	Razão de redução
l	[%]	Degré d'intermittence	<i>Grado de intermitencia</i>	Grau de intermitência
Jm	[Kg·m ²]	Moment d'inertie du moteur électrique	<i>Momento de inercia del motor eléctrico</i>	Momento de inercia do motor eletrico
Jr	[Kg·m ²]	Moment d'inertie du réducteur	<i>Momento de inercia del reductor</i>	Momento de inercia redução
Ju	[Kg·m ²]	Moment d'inertie des masses extérieures	<i>Momento de inercia de las masas externas</i>	Momento de inercia da massa externa
K	—	Facteur d'accélération des masses	<i>Factor de aceleración de las masas</i>	Fatore de aceleração da massa
M ₁	[Nm]	Couple applicable à l'entrée du réducteur	<i>Momento tursor de entrada del reductor</i>	Momento de torção em entrada redução
M ₂	[Nm]	Couple transmissible en sortie	<i>Momento torsorde salida del reductor</i>	Momento de torção em saída redução
Mn ₂	[Nm]	Couple nominal en sortie réducteur	<i>Momento tursor nominal de salida</i>	Momento de torção nominal em saída redução
Mr ₂	[Nm]	Couple nécessaire en sortie réducteur	<i>Momento tursor de la salida</i>	Momento de torção repedir em saída redução
Mc ₂	[Nm]	Couple calculé en sortie réducteur	<i>Momento tursor de de calculo de salida</i>	Momento de torção de calculo em saída redução
n ₁	[min ⁻¹]	Vitesse d'entrée réducteur	<i>Velocidad angular a la entrada reductor</i>	Velocidade angolare em entrada redução
n ₂	[min ⁻¹]	Vitesse de sortie réducteur	<i>Velocidad angular a la salida reductor</i>	Velocidade angolare em saída redução
P ₁	[kW]	Puissance en entrée réducteur	<i>Potencia de entrada reductor</i>	Potência em entrada redução
P ₂	[kW]	Puissance disponible en sortie réducteur	<i>Potencia de salida reductor</i>	Potência em saída redução
Pm	[kW]	Puissance nominale du moteur électrique	<i>Potencia nominal del motor eléctrico</i>	Potência nominal motor eletrico
Pn ₁	[kW]	Puissance nominale en entrée réducteur	<i>Potencia nominal de entrada</i>	Potência nominal em entrada redução
Pn ₂	[kW]	Puissance nominale en sortie réducteur	<i>Potencia nominal de salida</i>	Potência nominal em saída redução
Pr ₁	[kW]	Puissance nécessaire en entrée réducteur	<i>Potencia de entrada requerida</i>	Potência repedir em entrada redução
Pt	[kW]	Puissance thermique	<i>Potencia térmica</i>	Potência termica
Rd		Rendement dynamique	<i>Rendimiento dinámico</i>	Rendimento dinâmico
ta	[°C]	Température ambiante	<i>Temperatura ambiente</i>	Temperatura ambiente
tf	[min]	Temps de fonctionnement à charge constante	<i>Tiempo de funcionamiento con carga constante</i>	Tempo de funcionamento a cargo constante
tf	[min]	Temps de repos	<i>Tiempo de reposo</i>	Tempo de repouso
		Se référer à la page	<i>Volver a la pagina</i>	Voltar para a página



Informazioni generali / General information / Allgemeine Informationen

2

Potenza nominale in entrata Pn_1 [kW]

Potenza applicabile in entrata al riduttore, riferita alla velocità n_1 e ad un fattore di servizio $FS=1$. Per i motorriduttori vale:

$$Pn_1 = Pm \cdot FS$$

Potenza nominale in uscita Pn_2 [kW]

Potenza trasmessa all'uscita del riduttore. Si può calcolare con le seguenti formule:

$$Pn_2 = Pn_1 \cdot Rd$$

$$Pn_2 = \frac{Mn_2 \cdot n_2}{9550}$$

Momento torcente nominale in uscita Mn_2 [Nm]

Coppia trasmissibile in uscita al riduttore, riferita alla velocità n_1 e a quella corrispondente n_2 , e calcolata in base a un fattore di servizio $FS=1$.

$$Mn_2 = M_2 \cdot FS$$

Momento torcente richiesto in uscita Mr_2 [Nm]

Coppia richiesta dall'applicazione. Dovrà essere sempre soddisfatta la seguente condizione:

$$Mr_2 \leq Mn_2$$

$$Mr_2 = \frac{Pr_1 \cdot 9550 \cdot Rd}{n_2}$$

Momento torcente di calcolo in uscita Mc_2 [Nm]

Coppia di calcolo da utilizzare per la selezione del riduttore.

$$Mc_2 = Mr_2 \cdot FS \leq Mn_2$$

Rapporto di riduzione i

$$i = \frac{n_1}{n_2}$$

Rendimento dinamico Rd

Nel calcolo della Coppia Mn_2 indicata a catalogo, si è considerato il rendimento dei gruppi funzionanti a pieno carico dopo il rodaggio. I valori Rd dei riduttori sono i seguenti:

RFV..2

0.95

RFV..3

0.93

Velocità angolare n_1, n_2 [min^{-1}]

È la velocità determinata dal tipo di motorizzazione (n_1) e dal conseguente rapporto di riduzione del riduttore (n_2).

$$n_2 = \frac{n_1}{i}$$

È sempre consigliabile, dove la trasmissione lo permette, entrare con velocità inferiori a 1400 min^{-1} al fine di garantire condizioni ottimali di funzionamento. Sono comunque ammesse velocità di ingresso fino a 2800 min^{-1} senza incorrere in particolari controindicazioni.

It is always advisable – where transmission allows it – to enter with speeds lower than 1400 min^{-1} in order to ensure optimum running conditions. However, input speeds of up to 2800 min^{-1} may be used without incurring any particular problems.

Input rated power Pn_1 [kW]

This is the applicable power at input relating to speed n_1 and a service factor $FS=1$. The following is valid for motor reducers:

Output rated power Pn_2 [kW]

Power transmitted at gear reducer output can be calculated with the following formulas:

Rated torque at output Mn_2 [Nm]

Torque transmitted at gear reducer output relating to speed n_1 and the corresponding n_2 calculated on a service factor $FS=1$.

Required torque at output Mr_2 [Nm]

Torque corresponding to application requirements. The following conditions applies – always:

Calculated torque at output Mc_2 [Nm]

Torque value to be used to select a gear reducer.

Reduction ratio i

Dynamic efficiency Rd

Torque calculations Mn_2 indicated in the charts was calculated having units operating at mamimum load after initial running-in. The gear reducer's Rd values are as follows:

Max. Eintriebsleistung Pn_1 [kW]

Dies ist die max. zulässige Eintriebsleistung bei der Drehzahl n_1 und einem Sicherheitsfaktor $FS = 1$. Für Getriebemotoren gilt:

Max. Abtriebsleistung Pn_2 [kW]

Diese kann berechnet werden durch:

Maximale Abtriebsdrehmoment Mn_2 [Nm]

Übertragbares Abtriebsdrehmoment, abhängig von den Drehzahlen n_1 und n_2 . Berechnet auf Grundlage des Betriebsfaktors $FS=1$.

Benötigtes Abtriebsdrehmoment Mr_2 [Nm]

Folgende Bedingungen müssen immer gegeben sein:

Berechnetes Abtriebsdrehmoment Mc_2 [Nm]

Wird für die Auswahl des Getriebes benötigt.

Untersetzung i

Dynamischer Wirkungsgrad Rd

Die Drehmomentangaben Mn_2 in den Tabellen sind mit dynamischem Wirkungsgrad und max. Motorleistung nach der Einlaufzeit angegeben. Die Rd -Werte sind folgenden:

Drehzahlen n_1 und n_2 [min^{-1}]

Die Drehzahl ist abhängig vom Motortyp (n_1) und dem daraus folgenden Umsetzungsverhältnis (n_2).

Eine Eingangsdrehzahl von ca. 1400 min^{-1} ist empfehlenswert, um einen optimalen Betrieb zu gewährleisten. Eintriebsdrehzahlen bis zu 2800 min^{-1} sind ebenfalls möglich.



Puissance nominale en entrée réducteur Pn_1 [kW]

Puissance admissible en entrée par rapport à la vitesse n_1 et avec un facteur de service $FS=1$. Pour le moto-réducteur:

Potencia nominal de entrada Pn_1 [kW]
Potencia aplicable en la entrada del reductor, la cual hace referencia a la velocidad n_1 y a un factor de servicio $FS=1$. Para motorreductores es valida la siguiente formula:

$$Pn_1 = Pm \cdot FS$$

Potência nominal em entrada Pn_1 [kW]

Potência apropriado em entrada a redução referida a velocidade n_1 e a um fatore de serviço $FS=1$. Para o motoridutor vale:

Puissance nominale en sortie réducteur Pn_2 [kW]

Puissance transmise en sortie réducteur qui peut être calculée avec les formules suivantes:

Potencia nominal de salida Pn_2 [kW]

Potencia transmitida a la salida del reductor. Se puede calcular con las siguientes formulas:

$$Pn_2 = Pn_1 \cdot Rd \qquad Pn_2 = \frac{Mn_2 \cdot n_2}{9550}$$

Potência nominal em saída Pn_2 [kW]

Potência transmitida a saída do reductor se pode colocar com a seguinte formula:

Couple nominal de sortie réducteur Mn_2 [Nm]

Couple transmissible en sortie réducteur par rapport à la vitesse n_1 et à la correspondant n_2 , calculée sur la base d'un facteur de service $FS=1$.

Momento torsor nominal en la salida Mn_2 [Nm]

Par motor transmissible a la salida del reductor, referida a la velocidad n_1 y a la correspondiente n_2 y calculada en base a un factor de servicio $FS=1$.

$$Mn_2 = M_2 \cdot FS$$

Momento torção nominal em saída Mn_2 [Nm]

Cópia transmissão em saída a redução, referida a velocidade n_1 e a quella correspondente n_2 e calculada em base a um fatore de serviço $FS=1$.

Couple nécessaire en sortie réducteur Mr_2 [Nm]

Couple nécessaire à l'application. Respecter toujours la condition suivante:

Momento torsor requerido en la salida Mr_2 [Nm]

Par motor requerido de la aplicación. Deberá ser siempre respetada la siguiente condición:

$$Mr_2 \leq Mn_2 \qquad Mr_2 = \frac{Pr_1 \cdot 9550 \cdot Rd}{n_2}$$

Momento torção repedir em saída Mr_2 [Nm]

cópia repedir da aplicação, deverá ser sempre satisfeito a seguinte condição:

Calcule du couple en sortie réducteur Mc_2 [Nm]

Valeur du couple utilisée pour la selection du réducteur.

Momento torsor de cálculo en la salida Mc_2 [Nm]

Par motor de cálculo de utilizar para la selección del reductor.

$$Mc_2 = Mr_2 \cdot FS \leq Mn_2$$

Momento torção de calcolo em saída Mc_2 [Nm]

cópia de calcolo da utilizar para a seleção de redução.

Rapport de réduction i

Relación de reducción i

$$i = \frac{n_1}{n_2}$$

Razão de redução i

Rendement dynamique Rd

Les couples nominaux de sortie réducteur Mn_2 mentionnés dans les tableaux, ont été calculés avec un rendement Rd obtenu en fonctionnement à pleine charge après rodage:

Rendimiento dinámico Rd

En el cálculo del par motor Mn_2 indicado en el catálogo, se ha considerado el rendimiento de los grupos funcionantes a plena carga después del rodaje. Los valores Rd de los reductores son los siguientes:

RFV..2	0.95	RFV..3	0.93
--------	-------------	--------	-------------

Rendimento dinâmico Rd

No calulo da cópia Mn_2 indicada a catalogo, é considerado o rendimento do grupo funciona a tanta carga depois a primeira prova. O valor Rd da redução são o seguinte:

Vitesse angulaire n_1-n_2 [min⁻¹]

C'est la vitesse relative au moteur sélectionné (n_1) et la vitesse consécutive (n_2) au rapport de réduction i choisi.

Velocidad angular n_1-n_2 [min⁻¹]

Es la velocidad que viene determinada por el tipo de motorización utilizada (n_1) y de la consiguiente relación de reducción del reductor (n_2).

$$n_2 = \frac{n_1}{i}$$

Velocidade angular n_1-n_2 [min⁻¹]

É a velocidade determinada do tipo de motorização (n_1) e da consequente razão de redução de reductor (n_2).

Il est toujours préférable, quand la transmission le permet, d'utiliser une vitesse inférieure à 1400 min⁻¹, afin de garantir des conditions de fonctionnement optimales. Cependant une vitesse d'entrée de 2800 min⁻¹ peut être utilisée sans contre-indications particulières.

Es aconsejable, siempre que la transmisión lo permita, entrar con velocidades inferiores a 1400 min⁻¹ con el fin de garantizar las condiciones optimas de funcionamiento. También son admitidas velocidades de entrada de hasta 2800 min⁻¹ sin incurrir en ninguna contraindicación.

É sempre aconselhavel onde a transmissão o permite, entrar com velocidade inferior a 1400 min⁻¹ a fim de garanti condição ótima de funcionamento. São amissivel velocidade de ingresso fim a 2800 min⁻¹ sem incorrer em particular contra indicação.



Fattore di servizio FS / Service factor FS / Betriebsfaktor FS

3

Il fattore di servizio FS è il parametro che traduce in un valore numerico la gravosità del servizio che il riduttore è chiamato a svolgere, tenendo in considerazione, con sufficiente approssimazione della variabilità del carico e degli eventuali urti cui è sottoposto il riduttore per un determinato tipo di servizio.

Il grafico della tabella, permette di scegliere il fattore di servizio FS una volta stabilito i seguenti parametri:

- natura del carico in funzione del fattore di accelerazione delle masse K: A-B-C
- durata di funzionamento giornaliero: ore/giorno (h/d)
- frequenza di avviamento: avviamenti/ora
- classe di carico:
 - A** - $K \leq 0.30$ (carico uniforme)
 - B** - $0.30 < K \leq 3.0$ (carico con urti moderati)
 - C** - $3 < K \leq 10$ (carico con forti urti)

Eventuali valori intermedi di FS potranno essere ottenuti per interpolazione.

The service factor FS is a parameter that translates the operational burden of the gear reducer when running into a numerical value, at the same time taking into consideration (with sufficient approximation) any load variations or eventual shocks that the gear reducer might incur for a certain type of duty.

The graph below will allow you to choose the service factor FS once you have established the following facts:

- type of load based on the acceleration factor of the masses K: A-B-C
- operational running times in hours per day: h/d
- number of starts and stops per hour
- type of load:
 - A** - $K \leq 0.30$ (uniform load)
 - B** - $0.30 < K \leq 3.0$ (moderate shock load)
 - C** - $3 < K \leq 10$ (heavy shock load)

Any eventual FS intermediate values can be obtained by interpolation.

Der Betriebsfaktor fs gibt die Betriebsbelastung durch einen numerischen Wert wieder.

Diesen Wert sollte das Getriebe unter Beachtung der Belastungsvariabilität und den möglichen auftretenden Stößen erfüllen.

Die Tabelle ermöglicht die Auswahl des Betriebsfaktors (FS), nachdem folgende Parameter einmal festgesetzt worden sind:

- Die Belastungsart ist abhängig von den Massenbeschleunigungsfaktoren K: A-B-C
- Tägliche Getriebeaufzeit (h/d)
- Starthäufigkeit. Starts/Std
- Belastungstypen:
 - A** - $K \leq 0.30$ (gleichmäßige Belastung)
 - B** - $0.30 < K \leq 3.0$ (leichte Stoßbelastung)
 - C** - $3 < K \leq 10$ (starke Stoßbelastung)

Dazwischen liegende Werte können interpoliert werden.

Tab.1

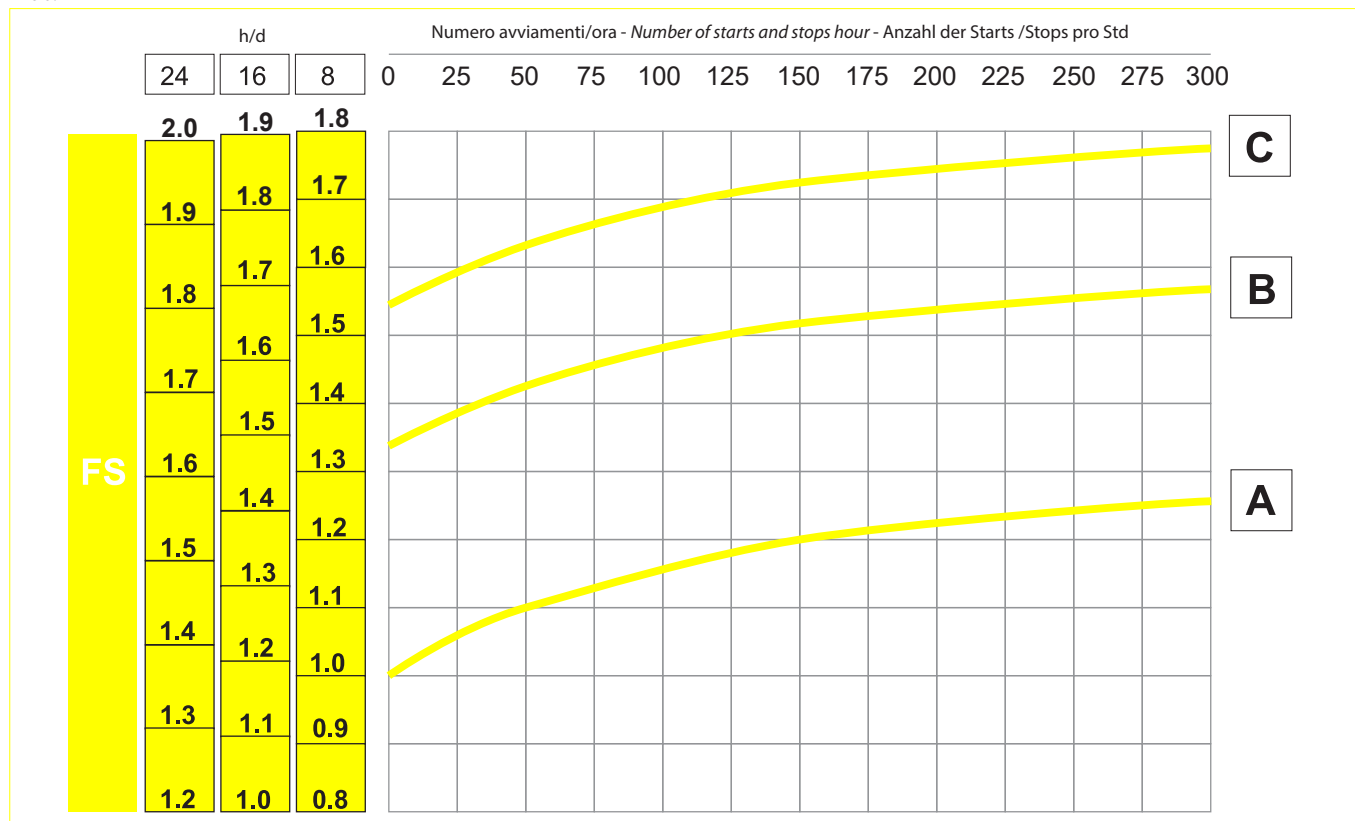

Fattore di accelerazione delle masse K

Serve per la determinazione del tipo di carico, e si ricava dalla relazione:

Acceleration factor of masses K

Used to determine the type of load, it can be obtained from the following equation:

$$K = \frac{J_u}{J_m}$$

dove:

Ju [Kgm²]: momento d'inerzia dinamico delle masse esterne

Jm [Kgm²]: momento d'inerzia del motore elettrico

where:

Ju [Kgm²]: dynamic moment of inertia of the external masses

Jm [Kgm²]: electric motor moment of inertia

Massenbeschleunigungsfaktor K

K dient dazu, den Belastungstyp zu bestimmen. Er läßt sich aus folgender Gleichung ableiten:

Hier gilt:

Ju [Kgm²]: Dynamischer Massenträgheitsmoment der angetriebenen Massen

Jm [Kgm²]: Massenträgheitsmoment des Elektromotors



Ce facteur prend en considération, avec suffisamment d'approximation, les variations de charges et des éventuels à-coups que le réducteur peut supporter pour un type spécifique de service.

Le graphique du tableau indique le Facteur de Service FS pour un usage avec les paramètres suivants:

- types de charges basés sur le facteur d'accélération des masses K: A-B-C
- temps de fonctionnement par jour (h/d)
- nombre de démarrage par heure
- type de charge:
 - A** - $K \leq 0.30$ (charge uniforme)
 - B** - $0.30 < K \leq 3.0$ (variation de charge et chocs modérés)
 - C** - $3 < K \leq 10$ (fortes variations de charge et chocs importants)

Les valeurs intermédiaires peuvent être obtenues par interpolation.

El factor de servicio FS es el parámetro que traduce en un valor numérico el esfuerzo del servicio, que el reductor realiza teniendo en consideración con una suficiente aproximación la variación de la carga y de los eventuales choques a los cuales se expone el reductor para un determinado tipo de servicio.

El gráfico de la siguiente tabla permite elegir el factor de servicio FS una vez establecidos los siguientes parámetros:

- naturaleza de la carga en función del factor de aceleración de las masas K: A-B-C
- duración del funcionamiento diario horas/día (h/d)
- frecuencia de arranque: arranques/hora
- tipo de carga:
 - A** - $K \leq 0.30$ (carga uniforme)
 - B** - $0.30 < K \leq 3.0$ (carga con choques moderados)
 - C** - $3 < K \leq 10$ (carga con choques fuertes)

Eventuales valores intermedios de FS podrán ser obtenidos por interpolación.

O fator de serviço FS é o parâmetro que traduz em um valor numeral a gravidade do serviço que o reductor é chamado praticar, tendo a consideração, com suficiente aproximação da distância da carga de eventual choque preparado mesmo posto o ridutor para um determinado tipo de serviço.

O desenho da tabela, permite de escolher o fator de serviço FS uma vez estabelecido o seguinte parâmetro:

- natura da carga em função do fator de aceleração da massa K : A-B-C
- tempo de funcionamento diária (hora/dia) (h/d)
- frequência de aviaamento/hora
- carga com forte choque:
 - A** - $K \leq 0.30$ (carga forma perfeita)
 - B** - $0.30 < K \leq 3.0$ (carga com choque moderada)
 - C** - $3 < K \leq 10$ (carga com forte choque)

Eventual valor intermédio de FS podem ser recebido por interpolação.

Tab.1

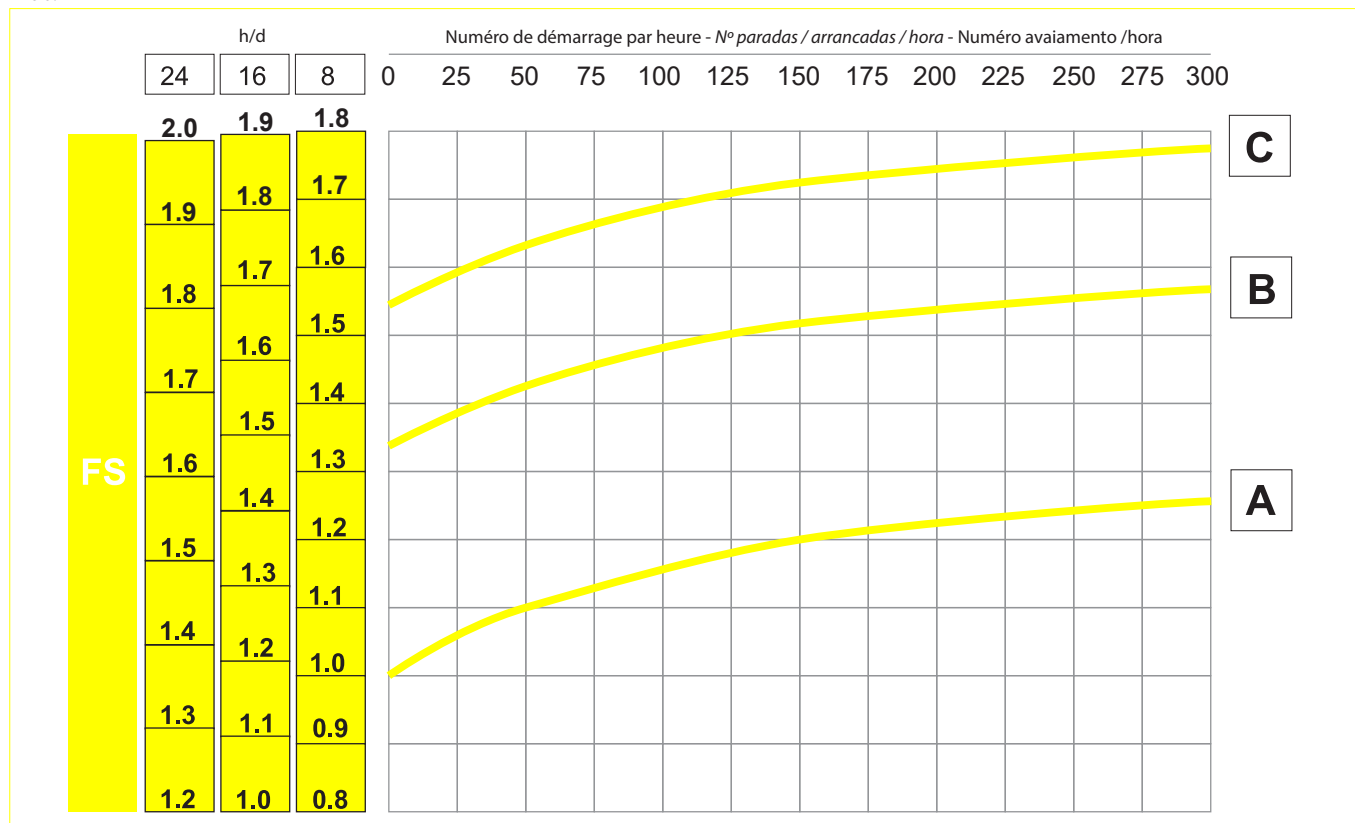

Facteur d'accélération des masses K

Utilisé pour déterminer le type de charge et peut être obtenu par l'équation suivante:

ou:
 Ju [Kgm²]: moment d'inertie dynamique des masses extérieures
 Jm [Kgm²]: moment d'inertie moteur électrique

Factor de aceleración de las masas K

Sirve para determinar el tipo de carga y se obtiene mediante la siguiente formula:

$$K = \frac{J_u}{J_m}$$

donde:
 Ju [Kgm²]: Momento de inercia dinámico de las masas externas
 Jm [Kgm²]: Momento de inercia del motor eléctrico

Fatore aceleração da massa K

Serve para a determinação do tipo de carga e se recebe da relação:

Onde:
 Ju [Kgm²]: momento de inercia dinámico da massa externa
 Jm [Kgm²]: momento de inercia do motor elétrico



Potenza termica / Thermal power / Thermische Leistung

4

La potenza termica P_t è un valore che indica il limite termico del riduttore e rappresenta la potenza che può essere applicata all'entrata del riduttore in servizio continuo e alla temperatura ambiente $t_a=20^\circ\text{C}$, senza che si producano danneggiamenti alle parti interne e un degrado del lubrificante (vedi tab. 2).

Se il funzionamento del riduttore è intermittente o la temperatura ambiente t_a è diversa da 20°C , il valore di P_t deve essere corretto tramite il fattore moltiplicativo indicato nella tabella 3.

Per i riduttori con tre stadi di riduzione la verifica della potenza termica non è necessaria perchè quest'ultima è superiore alla potenza trasmissibile P_{n1} .

The thermal power P_t is a value that indicates the thermal limit of the gearbox: it represents the power that can be applied to the gearbox input in continuous duty and the ambient temperature $t_a = 20^\circ\text{C}$, without causing damage to the internal parts and a degradation of the lubricant (see tab. 2).

If the operation of the gearbox is intermittent or the ambient temperature t_a is other than 20°C , the P_t value must be corrected using the multiplying factor indicated in table 3.

For gearboxes with three reduction stages, the verification of the thermal power is not necessary because the latter is higher than the transmissible power P_{n1} .

Die Heizleistung P_t ist ein Wert, der die thermische Grenze des Getriebes angibt: Sie stellt die Leistung dar, die im Dauerbetrieb und bei Raumtemperatur $t_a=20^\circ\text{C}$ am Eingang des Getriebes anwendbar ist, ohne die Innenteile zu beschädigen und den Schmierstoff abzubauen (siehe Tabelle 2).

Bei Aussetzbetrieb des Getriebes oder einer anderen Raumtemperatur t_a als 20°C , muss der P_t -Wert durch Multiplikation des in Tabelle 3 angegebenen Faktors korrigiert werden.

Bei Getrieben mit drei Untersetzungsstufen ist eine Überprüfung der Heizleistung nicht erforderlich, da diese höher ist als die übertragbare Leistung P_{n1} .

Tab.2

RFV		
Temperatura ambiente / Ambient temperature / Umgebungstemperatur 20°C		
	$n1 = 1400 \text{ rpm}$	$n1 = 2800 \text{ rpm}$
252	4.0	2.9
302	9.1	6.5
352	11.7	8.5
402	14.3	10.4
502	21.5	15.0

Tab.3

ft					
ta (°C)		Servizio intermittente / Intermittent duty / Aussetzender Betrieb			
		Grado di intermittenza / Degree of intermittence / Relative Einschaldauer [I]			
Servizio continuo Continuous duty Dauerbetrieb		80%	60%	40%	20%
40	0.80	1.1	1.3	1.5	1.6
30	0.85	1.3	1.5	1.6	1.8
20	1.0	1.5	1.6	1.8	2.0
10	1.15	1.6	1.8	2.0	2.3

Il grado di intermittenza (I) % è dato dalla formula:

The degree of intermittence (I) % is given by the formula:

Relative Einschaldauer ist durch folgende Formel gegeben:

$$I = \frac{t_f}{t_f + t_r} \cdot 100$$

t_f = tempo di funzionamento a carico costante (min)

t_f = operating time with constant load (min)

t_f = Betriebszeit mit Dauerlast (min)

t_r = tempo di riposo (min)

t_r = rest time (min)

t_r = Aussetzzeit (min)

La condizione da verificare è la seguente:

The condition to be verified is the following:

Zu überprüfen ist der folgende Zustand:

$$P_{r1} \leq P_t \cdot ft$$



Puissance thermique / Potencia térmica / Potência térmica

La puissance thermique Pt est une valeur qui indique la limite thermique du réducteur : représente la puissance qui peut être appliquée à l'entrée du réducteur en service continu et à la température ambiante ta=20°C, sans que des endommagements aux parties internes et une dégradation du lubrifiant ne se produisent (voir le tab. 2). Si le fonctionnement du réducteur est intermittent ou la température ambiante ta est différente de 20 °C, la valeur de Pt doit être corrigée avec le facteur de multiplication dans le tableau 3. Pour les réducteurs avec trois stades de réduction, la vérification de la puissance thermique n'est pas nécessaire car cette dernière est supérieure à la puissance transmissible Pn₁.

La potencia térmica Pt es un valor que indica el límite térmico del reductor: representa la potencia que puede aplicarse a la entrada del reductor en servicio continuado, y la temperatura ambiente ta=20°C, sin que se produzcan daños en las partes internas ni se deteriore el lubricante (véase tab. 2). Si el funcionamiento del reductor es intermitente o la temperatura ambiente ta es distinta de los 20°C, el valor de Pt debe corregirse mediante el factor de multiplicación indicado en la tabla 3. Para los reductores con tres fases de reducción la comprobación de la potencia térmica no es necesaria, porque esta última es superior a la potencia que se puede transmitir Pn₁.

A potência térmica Pt é um valor que indica o limite térmico do reductor: representa a potência que pode ser aplicada à entrada do reductor em serviço contínuo e à temperatura ambiente ta = 20°C, sem danificar as partes internas nem degradar o lubrificante (ver a Tab. 2). Se o funcionamento do reductor for intermitente ou a temperatura ambiente ta for diferente de 20°C, o valor de Pt deverá ser corrigido através do fator multiplicativo indicado na tabela 3. Para os redutores com três estágios de redução, a verificação da potência térmica não é necessária porque esta última é superior à potência transmissível Pn₁.

Tab.2

RFV	Température ambiante / Temperatura ambiente / Temperatura ambiente 20°C	
	n1 = 1400 rpm	n1 = 2800 rpm
252	4.0	2.9
302	9.1	6.5
352	11.7	8.5
402	14.3	10.4
502	21.5	15.0

Tab.3

ta (°C)		ft			
		Service intermittent / Servicio intermitente / Serviço intermitente			
		Degré d'intermittence / Grado de intermitencia / Grau de intermitência [I]			
		80%	60%	40%	20%
40	0.80	1.1	1.3	1.5	1.6
30	0.85	1.3	1.5	1.6	1.8
20	1.0	1.5	1.6	1.8	2.0
10	1.15	1.6	1.8	2.0	2.3

Le degré d'intermittence (I) % est donné par la formule :

El grado de intermitencia (I) % se obtiene con la fórmula:

O grau de intermitência (I) % é dado pela fórmula:

$$I = \frac{tf}{tf + tr} \cdot 100$$

tf = temps de fonctionnement à charge constante (min)

tiempo de funcionamiento con carga constante (min)

tf = tempo de funcionamento a cargo constante (min)

tr = temps de repos (min)

tr = tiempo de reposo (min)

tr = tempo de repouso (min)

La condition à vérifier est la suivante:

La condición que se debe verificar es la siguiente:

A condição que deve ser verificada é a seguinte:

$$P_{r1} \leq Pt \cdot ft$$



Per selezionare correttamente un riduttore o un motoriduttore, si consiglia di operare come segue:

Scelta dei motoriduttori

a) Determinare il fattore di servizio FS in funzione del tipo di carico, del numero di avviamenti/ora e del numero di ore di funzionamento giornaliero (tab.1).

b) Dalla coppia Mr_2 conoscendo n_2 e il rendimento dinamico (Rd), ricavare la potenza di entrata richiesta dall'applicazione:

Il valore Rd del riduttore è riportato nella tabella a pag. 6.

c) Ricercare fra le tabelle dei dati tecnici dei motoriduttori quella corrispondente ad una potenza motore:

La potenza Pm dei motori riportata a catalogo si riferisce al servizio continuo S1.

Scegliere poi, in base alla velocità di uscita n_2 , il motoriduttore con un fattore di servizio FS calcolato maggiore o uguale al fattore di servizio FS della tabella 1.

Scelta dei riduttori e dei riduttori predisposti per motori IEC

a) Determinare il fattore di servizio Fs.

b) Conoscendo la coppia di uscita richiesta dalla applicazione Mr_2 , si procede alla definizione della coppia di calcolo:

c) Disponendo della coppia di calcolo Mc_2 e del rapporto di riduzione [i], si ricercherà nelle tabelle il riduttore che, in funzione del rapporto [i] prossimo a quello calcolato, proponga una coppia nominale in uscita:

Se al riduttore scelto dovrà essere applicato un motore elettrico verificarne l'applicabilità consultando le predisposizioni possibili (IEC B5, o IEC B14) riportate nelle tabelle dei dati tecnici.

To select a gearbox or gearmotor correctly, it is advisable to proceed as follows:

Selecting the gearmotors

a) Determine the service factor FS according to the type of load, the number of start-ups/hour and the number of daily operating hours (tab.1).

b) Providing that torque Mr_2 , speed n_2 and dynamic efficiency (Rd) are known, obtain the input power required by the application:

$$Pr_1 = \frac{Mr_2 \cdot n_2}{9550 \cdot Rd} \text{ [kW]}$$

The value Rd of the gearbox is shown in the table on page 6.

c) Look through the tables of the gearmotor technical data to find the motor power:

$$Pm \geq Pr_1$$

The power Pm of the motors listed in the catalogue refers to continuous duty S1.

Next, according to the output speed n_2 , select a gearmotor having a calculated service factor FS higher than or equal to the service factor FS given in table 1.

Selecting gearboxes and gearmotors designed for IEC motors

a) Determine the service factor Fs.

b) Knowing the output torque required by the application Mr_2 , proceed with the calculation of the torque:

$$Mc_2 = Mr_2 \cdot FS$$

c) Now that you have calculated the torque Mc_2 and reduction ratio [i], consult the tables to find the gearbox that has a ratio [i] closest to your calculated ratio and gives a rated output torque of:

$$Mn_2 \geq Mc_2$$

If the selected gearbox must be fitted with an electric motor, check its applicability by consulting the possible configurations IEC B5 or IEC B14, shown in the technical data tables.

Für die richtige Wahl eines Getriebes oder Getriebemotors ist Folgendes in Augenschein zu nehmen:

Wahl eines Getriebemotors

a) Den Betriebsfaktor FS in Abhängigkeit der Art der Last, der Anzahl der Startvorgänge/Stunde und der Anzahl der Betriebsstunden pro Tag (Tab. 1) bestimmen.

b) Aus dem Mr_2 Drehmoment, n_2 und den dynamischen Wirkungsgrad (Rd) kennend, wird die von der Anwendung benötigte Eingangsleistung abgeleitet:

Der Rd-Wert des Getriebes ist in der Tabelle auf Seite 6 angeführt.

c) Unter den Tabellen der technischen Daten der Getriebemotoren jene herauszusuchen, die einer Motorleistung

Die im Katalog angeführte Leistung Pm der Motoren bezieht sich auf den Dauerbetrieb S1.

Auf der Grundlage der Abtriebs-Drehzahl n_2 den Getriebemotor mit einem FS-Betriebsfaktor, der größer oder gleich dem FS-Betriebsfaktor berechnet wurde, in Tabelle 1 auswählen.

Wahl der Getriebe und der für IEC Motoren vorgerüsteten Getriebe

a) Den Betriebsfaktor FS bestimmen.

b) Das von der Anwendung Mr_2 erforderte Ausgangsdrehmoment kennend kann das Berechnungsmoment bestimmt werden:

c) Nachdem das Berechnungsmoment Mc_2 und das Untersetzungsverhältnis [i] bekannt sind, wird in den Tabellen das Getriebe gesucht, das je nach Übersetzung [i] nahe dem berechneten ein Nenn-Ausgangsdrehmoment vorgibt:

Soll am gewählten Getriebe ein Elektromotor eingebaut werden, ist dessen Anwendbarkeit anhand der in den Tabellen der technischen Daten angegebenen möglichen Vorrüstungen (IEC B5 oder IEC B14) zu überprüfen.



Pour sélectionner correctement un réducteur ou un motoréducteur, il est conseillé d'opérer de la manière suivante :

Choix des motoréducteurs

- a) Déterminer le facteur de service FS en fonction du type de charge, du nombre de démarrages/heure et du nombre d'heures de fonctionnement quotidien (tab.1).
- b) Du couple Mr_2 connaissant n_2 et le rendement dynamique (Rd), obtenir la puissance d'entrée requise par l'application :

La valeur Rd du réducteur est reportée dans le tableau à la page 6.

- c) Rechercher parmi les tableaux des données techniques des motoréducteurs celle qui correspond à une puissance moteur :

La puissance Pm des moteurs reportée dans le catalogue concerne le service continu S1.
Choisir ensuite, en fonction de la vitesse de sortie n_2 , le motoréducteur avec un facteur de service FS calculé supérieur ou égal au facteur de service FS du tableau 1.

Choix des réducteurs et des réducteurs prévus pour les moteurs IEC

- a) Déterminer le facteur de service Fs.
- b) Connaissant le couple de sortie demandé par l'application Mr_2 , on procède à la définition du couple de calcul :

- c) En disposant du couple de calcul Mc_2 et du rapport de réduction [i], on recherchera dans les tableaux le réducteur qui, en fonction du rapport [i] proche de celui calculé, propose un couple nominal en sortie :

Si au réducteur choisi devra être appliqué un moteur électrique, en vérifier l'applicabilité en consultant les prédispositions possibles (IEC B5, ou IEC B14) reportées dans les tableaux des données techniques.

Para seleccionar correctamente un reductor o un motorreductor se recomienda hacer lo siguiente:

Elección de los motorreductores

- a) *Calcular el factor de servicio FS en base al tipo de carga, al número de arranques por hora y a la cantidad de horas de funcionamiento diarias (tab.1).*
- b) *Desde el par Mr_2 conociendo n_2 y el rendimiento dinámico (Rd), calcular la potencia de entrada que exige la aplicación:*

$$Pr_1 = \frac{Mr_2 \cdot n_2}{9550 \cdot Rd} \text{ [kW]}$$

El valor Rd del reductor se indica en la tabla de la pág. 6.

- c) *Buscar entre las tablas de los datos técnicos de los motorreductores la que corresponde a una potencia del motor:*

$$Pm \geq Pr_1$$

*La potencia Pm de los motores indicada en el catálogo se refiere al servicio continuado S1.
Escoger a continuación el motorreductor con un factor de servicio FS calculado mayor o igual al factor de servicio FS de la tabla 1, en base a la velocidad de salida n_2 .*

Selección de los motorreductores y de los reductores preparados para motores IEC.

- a) *Calcular el factor de servicio Fs.*
- b) *Conociendo el par de salida exigido por la aplicación Mr_2 , se procede a definir el par para el cálculo:*

$$Mc_2 = Mr_2 \cdot FS$$

- c) *Si disponemos del par de cálculo Mc_2 y de la relación de reducción [i], se buscará en las tablas del reductor, que en base a la relación [i] cercana a la calculada, propondrá un par nominal en salida:*

$$Mn_2 \geq Mc_2$$

Si al reductor escogido se le deberá colocar un motor eléctrico, comprobar si se puede aplicar consultando las predisposiciones posibles (IEC B5, o IEC B14) indicadas en las tablas de datos técnicos.

Para seleccionar corretamente um reductor ou um motorreductor, é aconselhável operar da seguinte forma:

Escolha dos motorreductores

- a) Determinar o fator de serviço FS em função do tipo de carga, do número de ativações/hora e do número de horas de funcionamento diário (tab.1).
- b) A partir do binário Mr_2 conhecendo n_2 e o rendimento dinâmico (Rd), obter a potência de entrada exigida pela aplicação:

O valor Rd do reductor está apresentado na tabela da pág. 6.

- c) Pesquisar entre as tabelas dos dados técnicos dos motorreductores que corresponde à potência do motor:

A potência Pm dos motores referida no catálogo refere-se ao serviço contínuo S1.
Escolher depois, conforme a velocidade de saída n_2 , o motorreductor com um fator de serviço FS calculado maior ou igual ao fator de serviço FS da tabela 1.

Escolha dos reductores e dos reductores idóneos para motores IEC

- a) Determinar o fator de serviço Fs.
- b) Conhecendo o binário de saída exigido pela aplicação Mr_2 , definir o binário de cálculo:

- c) Possuindo o binário de cálculo Mc_2 e a relação de redução [i], é preciso procurar nas tabelas o reductor que, em função da relação [i] próxima daquela calculada, propõe um binário nominal de saída:

Se ao reductor escolhido for instalado um motor elétrico, verificar a sua aplicabilidade consultando os pré-arranjos possíveis (IEC B5, ou IEC B14) apresentados nas tabelas dos dados técnicos.



Verifiche / Check / Überprüfungen

6

Effettuata la corretta selezione del riduttore o motoriduttore, si consiglia di procedere alle seguenti verifiche:

Momento torcente massimo

I sovraccarichi istantanei previsti dall'applicazione non devono essere superiori al doppio dei valori di momento torcente del riduttore riportati a catalogo Mn2.

Potenza termica

La potenza termica del riduttore deve avere un valore uguale o maggiore della potenza richiesta dall'applicazione (pag. 10).

Carichi radiali e assiali

I carichi radiali e assiali agenti sugli alberi lenti e veloci devono rientrare nei valori di catalogo ammessi.

Once you have correctly chosen the type of gear reducer or gearmotor, it is then advisable to check that the following apply:

Maximum torque

The maximum torque at instantaneous peak overloads of the application must not be higher than the double of the torque values of the gear reducer given in this catalogue Mn2.

Thermic power

A gear reducer's thermic power value must be equal to or higher than the power needed by the appliance. (See pg. 10).

Radial and thrust loads

Radial and thrust loads on the input and output shafts must be within the permissible loads given in this catalogue.

Nachdem das richtige Getriebe bzw. der richtige Getriebemotor ausgewählt wurde, empfehlen wir folgende Überprüfungen durchzuführen:

Maximales Drehmoment

Die unmittelbaren Überbelastungen, welche von der Anwendung vorgesehen sind, dürfen nicht mehr als das Doppelte der im Katalog angegebenen Drehmomentwerte sein Mn2.

Thermische Leistung

Die thermische Leistung des Getriebes sollte einen Wert größer oder gleich dem Wert haben, der der benötigten Leistung der Anwendung entspricht (s.S.10).

Radial und Axialbelastung

Die Radial- und Axialbelastungen, welche auf die Ein- und Abtriebswellen wirken, sollten innerhalb der zugelassenen Katalogwerte liegen.

7

Installazione / Installation / Installation

Per l'installazione del riduttore è consigliabile attenersi alle seguenti indicazioni:

- Verificare che non vi siano stati danni durante lo stoccaggio o il trasporto
- Pulire accuratamente il riduttore dai residui dell'imballaggio a da eventuali prodotti protettivi
- Verificare che i dati riportati nella targhetta di identificazione corrispondano a quelli specificati in fase di ordinativo
- Verificare che la struttura della macchina sulla quale si installa il riduttore abbia caratteristiche di rigidità e di robustezza sufficienti a supportarne il peso proprio e le forze generate nel funzionamento; accertarsi che la macchina sia spenta e che ne sia impedito il riavvio accidentale
- Il fissaggio sulla macchina deve essere stabile per evitare qualsiasi vibrazione; verificare che le superfici di accoppiamento siano piane e ben pulite. Prima del montaggio lubrificare le superfici di contatto onde evitare grippaggi o ossidazioni
- Assicurare l'allineamento tra motore - riduttore e tra riduttore - macchina operatrice
- Gli organi che vanno calettati sugli alberi di uscita del riduttore devono essere lavorati con tolleranza ISO H7 per evitare accoppiamenti troppo bloccati che potrebbero danneggiare il riduttore stesso. Per il montaggio e lo smontaggio di tali organi si consiglia l'utilizzo di adeguati tiranti ed estrattori usufruendo dell'apposito foro filettato posto in testa alle estremità degli alberi d'uscita. Non servirsi di martelli o altri strumenti impropri per non danneggiare gli alberi o i supporti dei riduttori

Please read this chapter carefully and follow all instructions before installing the gearbox:

- *Check that nothing has been damaged during transport or storage*
- *Make sure that the gearbox is free from all packaging and any eventual protective products*
- *Check that the information printed on the identification plate correspond to those specified on the order*
- *After making sure that the machine on which the gearbox is to be installed is completely switched off and cannot be accidentally turned on, check that it is sturdy and rigid enough to withstand the weight and the forces generated by the gear reducer when running*
- *Make sure that the gearbox is correctly secured to avoid any kind of vibrations and that the coupling parts are flat and clean. Before assembly lubricate the contact parts to avoid seizures or oxidation*
- *Check that the alignment between the motor and the gearbox and between the gear reducer and operational machine is perfect*
- *Parts that connect to the gearbox's output shaft must be machined to ISO H7 tolerance to avoid any tightly blocked couplings that could damage the gear reducer. For the assembly and removal of these parts use suitable pullers or extractors using the specifically designed threaded hole at the end of the output shaft. Do not use hammers or other improper tools that may damage the shafts or the supporting stand*

Die folgenden Einbauanleitungen sollten beachtet werden:

- Stellen Sie sicher, daß während des Transports keinerlei Schäden verursacht wurden
- Entfernen Sie sorgfältig alle Reste der (Schutz-)Verpackung
- Stellen Sie sicher, daß die Angaben auf dem Typenschild mit Ihren Angaben in der Bestellung übereinstimmen
- Stellen Sie sicher, daß die Maschine, in die das Getriebe eingebaut werden soll, ausreichend robust und stabil ist, um dem Eigengewicht des Getriebes und den während der Inbetriebnahme auftretenden Kräften standzuhalten
- Stellen Sie sicher, daß das Getriebe gegen dauerhafte Vibrationseinflüsse geschützt ist
- Stellen Sie sicher, daß die Oberflächenverbindungen gereinigt und eben sind. Vor der Montage müssen die Oberflächenkontakte geschmiert werden, um Oxidation und ein Heißlaufen zu vermeiden
- Stellen Sie sicher, daß Motor und Getriebe miteinander verbunden sind und ebenso Maschine und Getriebe
- Alle Anbauteile, die an die Abtriebswellen angebaut werden, müssen mit der Passung nach ISO H7 gefertigt sein, da es sonst durch Schwingungen zu einem frühzeitigen Getriebeausfall kommen kann. Für Montage und Demontage der Anbauteile wird der Gebrauch von geeigneten Zugstangen und Ausziehern empfohlen. Benutzen Sie hierfür die eigens dafür bestimmte Gewindebohrung an den Enden der Abtriebswellen. Gebrauchen Sie keine Hämmer oder andere ungeeignete Werkzeuge, da sonst die Wellen oder die Halter der Getriebe beschädigt werden könnten



Après avoir correctement sélectionné le réducteur ou moto-réducteur, il est recommandé de vérifier ce qui suit:

Couple maximum

Les surcharges instantanées prévues par l'application ne doivent pas excéder le double des valeurs du couple du réducteur indiquées dans le catalogue Mn2.

Puissance thermique

La puissance thermique du réducteur doit avoir une valeur supérieure ou égale à la puissance nécessaire à l'application (pag. 11).

Charges radiales et axiales

Les charges radiales et axiales sur l'arbre d'entrée et de sortie doivent être dans les valeurs données.

Efectuada la correcta selección del reductor o motoreductor, se aconseja de proceder a las siguientes verificaciones:

Momento Torsor máximo

Las sobrecargas instantáneas previstas en la aplicación no tienen que ser superiores al doble de los valores del momento torsor del reductor presentados en el catálogo Mn2.

Potencia Térmica

La Potencia térmica del reductor debe tener un valor igual o mayor a la Potencia requerida de la aplicación pag.11.

Cargas radiales y axiales

Las cargas radiales y axiales que actúan en los ejes lentos (salida) y rápidos (entrada) deben entrar en los valores admitidos en el catálogo.

Efetuada a correta seleção do ridutor ou motoridutor se aconselha de seguir a seguinte verificação:

Momento de torção máximo

Mais carga instantane previsto da aplicação não deve ser superior a dobro do valor do momento torção do ridutor riporta a catalogo Mn2.

Potência termica

A potência termica do ridutor deve ter um valor igual ou maior da potência da aplicação (pag. 11).

Cargue radial e empuxo

A cargue radial e empuxo em função ao eixo lento e veloz devem rientrare no valor do catalogo metido.

Installation / Instalación / Instalação

Observer la procédure d'installation suivante:

- Vérifier l'absence de dommages éventuellement subis pendant le stockage ou le transport
- Nettoyer le réducteur des résidus de l'emballage et d'autres produits de protection
- Vérifier que les données sur la plaque d'identification correspondent à celles de la commande
- Vérifier que la structure de la machine sur laquelle on installe le réducteur ait les caractéristiques de rigidité et robustesse aptes à en supporter le poids et les forces générées par son fonctionnement; la machine doit être éteinte
- L'ancrage sur la machine doit être stable pour éviter des vibrations; vérifier que les surfaces d'accouplement soient plat et propres. Avant le montage, lubrifier les surfaces de contact afin d'éviter gripages et oxydation
- Vérifier que l'alignement entre le moteur et le réducteur ainsi qu'entre le réducteur et le système qu'il commande, soit correct
- Les éléments devant être montés sur l'arbre de sortie du réducteur doivent être usinés avec une tolérance ISO H7, afin d'éviter de provoquer des altérations des éléments du réducteur. Pour monter ou démonter les éléments employer des systèmes de poussée ou d'extraction utilisant le trou taraudé situé en bout d'arbre de sortie ne pas utiliser de marteaux ou d'autres instruments impropres pour ne pas endommager les arbres ou les supports des réducteurs

Para la instalación del reductor se aconseja seguir las siguientes indicaciones:

- *Verificar que no se hayan producidos daños durante el almacenamiento y el transporte*
- *Limpiar el reductor de los residuos del embalaje y de eventuales productos protectores*
- *Verificar que los datos reportados en la placa de identificación correspondan a los especificados en la orden*
- *Verificar que la estructura de la máquina sobre la cual se instala el reductor sea rígida y robusta para soportar el propio peso y la fuerza generada del funcionamiento; asegurarse que la máquina este apagada y que no se produzca un encendido accidental*
- *La fijación de la máquina debe ser estable para evitar cualquier vibración*
- *Verificar que las superficies del acoplamiento sean planas y esten limpias. Antes del montaje lubricar las superficies de contacto para evitar gripaje y oxidación*
- *Asegurar el alineamiento entre motor-reductor y entre reductor-máquina operadora. Los órganos que van sobre el eje de salida del reductor deben ser trabajados con tolerancia ISO H7 para evitar acoplamientos demasiado bloqueados que puedan dañar el reductor. Para el montaje y desmontaje de tales órganos se aconseja la utilización de adecuados tirantes y extractores aprovechando el correspondiente orificio roscado dispuesto en las cabezas de las extremidades de los ejes de salida. No usar martillos u otros instrumentos inadecuados para no dañar los ejes o los soportes del reductor*

Para a instalação do ridutor e conselhado ter as seguintes indicações:

- Verificar que não tene parte danificada durante a armazenagem e o transporte
- Limpar perfeitamente o ridutor do resto da embalagem e da eventuale produtor protetivo
- Verificar que os dados reportados na etiqueta de identificação corresponde aquele especificado em fase de ordem
- Verificar que a estrutura da máquina sobre qual se instala o ridutor haja característica de rigidez e de segurança suficiente a suportar o proprio peso, e a força geral no funcionamento: observar se a máquina seja desligada e que seja impedida de perigo accidental
- A fixagem sobre a máquina deve ser estável, para evitar qualquer vibração Verificar que a superfície de acoplamento são direitas e bem limpos. Antes da montagem lubrificar a superfície de contato onde evitar estraga e envelhencer
- Segurança no aliamento no motor- ridutor pra ridutor- máquina de operação
- Os órgãos que vão caletati sobre eixo de saída do ridutor devem ser trabalhada com tolerância ISO H7 para evitar acoplamento muito bloqueado que pode quebrar o ridutor para a montagem e desmontagem de tal organi se aconselha o utilizo de adequado tirante e estrator usufruindo do buraco filetado posicionado em cabeça a extremitar eixo saída
- Não usar martelo ou outro tipo de instrumento para não quebrar o eixo ou suporte do ridutor



7

- L'accoppiamento dell'albero di entrata cavo del riduttore, viene normalmente eseguito con perni aventi tolleranze ISO h6; in ogni caso il montaggio deve avvenire senza forzature
- Accertarsi che il montaggio di pignoni o pulegge a sbalzo sugli alberi dei riduttori, sia conforme alle verifiche di ammissibilità dei carichi risultanti
- Accertarsi, per i riduttori con indicatore di livello olio, che la posizione di quest'ultimo sia conforme alla posizione di montaggio del riduttore; per i riduttori forniti completi di lubrificante si raccomanda, effettuata l'installazione, di sostituire il tappo chiuso utilizzato per il trasporto, con il tappo di sfiao fornito a corredo
- Eseguire il primo riempimento, o l'eventuale rabbocco dell'olio facendo sempre riferimento alla mezzeria del tappo del livello
- I riduttori forniti con lubrificazione permanente non necessitano di questa procedura
- Prima della messa in servizio del riduttore accertarsi che la macchina che lo incorpora sia in regola con le disposizioni della Direttiva Macchine 2006/42/CE e successivi aggiornamenti.
- Verificare che il valore della tensione di alimentazione stampigliata sulla targhetta del motore elettrico coincida con la tensione di rete
- La verniciatura non deve assolutamente interessare i piani lavorati, il bordo esterno degli anelli di tenuta, fori esistenti sui tappi di sfiao, quando presenti e la targhetta di identificazione
- Se il funzionamento prevede urti o sovraccarichi, si devono adottare salvamotori, limitatori di coppia, giunti di sicurezza, ecc.
- Per i riduttori installati all'esterno prevedere opportune protezioni contro l'esposizione diretta agli agenti atmosferici e alla radiazione solare. Per installazioni in ambienti umidi, adottare adeguati protettivi sulle superfici lavorate del riduttore
- L'utilizzo dei motori a 2 poli è consigliato per servizi intermittenti, a causa dell'elevata temperatura che si può registrare durante il funzionamento
- Nel caso di temperature ambiente non comprese tra -20°C e +40°C contattare il nostro servizio tecnico.
- *The gearbox's hollow input shaft is normally coupled with shafts with pins with ISO h6 tolerances; in any case, assembly must take place without forcing.*
- *Make sure that the assembly of overhanging pinions and pulleys on the shafts of the gearboxes complies with the admissibility checks of the resulting loads.*
- *Make sure, for gearboxes with oil level indicator, that the position of the latter complies with the gearbox assembly position; for gearboxes supplied with lubricant it is recommended, after installation, to replace the closed plug used for transport, with the breather plug provided*
- *Always refer to the centreline of the oil level plug, when filling the gearbox with oil for the first time or when topping up*
- *Gearboxes supplied with permanent lubrication do not require this procedure*
- *Before putting the gearbox into service, make sure that the machine that incorporates it complies with the provisions of Machinery Directive 2006/42/EC and subsequent updates.*
- *Check that the supply voltage printed on the information plate coincides with the mains power supply*
- *The paintwork should not in any way touch machined surfaces, the edges of sealing rings, existing holes on the breather plugs, if any, and the identification plate*
- *If operation involves impacts or overloads, then motor protective devices, torque limiters, safety couplings, etc. must be installed*
- *For gearboxes installed outdoors provide suitable protection against direct exposure to weathering and sunlight. For installations in damp environments, provide adequate protections for the machined surfaces of the gearbox*
- *The use of 2-pole motors is recommended for intermittent duty, due to the high temperature that can be recorded during operation*
- *In the case of ambient temperatures not ranging between -20°C and +40°C, contact our technical service centre.*
- Die Kupplung der Eingangs-Hohlwelle des Getriebes wird in der Regel mithilfe von Bolzen, die eine Toleranz ISO h6 aufweisen, bewerkstelligt; in jedem Fall müssen die Montagearbeiten ohne Forcierung erfolgen.
- Sich vergewissern, dass die Montage der überstehenden Ritzel oder Riemenscheiben auf den Getriebewellen mit den Zulässigkeitsprüfungen für die resultierenden Lasten übereinstimmt.
- Bei Getrieben mit Ölstandanzeige ist darauf zu achten, dass die Position der Ölstandanzeige mit der Montageposition des Getriebes übereinstimmt; bei Getrieben, die komplett mit Schmiermittel geliefert werden, wird empfohlen, nach der Montage den für den Transport verwendeten geschlossenen Stopfen durch den mitgelieferten Entlüftungsstopfen zu ersetzen.
- Die Erstbefüllung oder ggf. das Nachfüllen des Öls ist immer unter Bezugnahme auf die Mittellinie der Füllstandsanzeige durchzuführen.
- Getriebe, die mit Dauerschmierung geliefert werden, benötigen keinen Ölwechsel
- Vor der Inbetriebnahme des Getriebes ist sicherzustellen, dass die Maschine, in die es eingebaut ist, den Bestimmungen der Maschinenrichtlinie 2006/42/EG und nachfolgenden Aktualisierungen entspricht.
- Überprüfen, ob der auf dem Typenschild des Elektromotors angegebene Wert der Versorgungsspannung mit der Netzspannung übereinstimmt.
- Die Lackierung darf keinesfalls die bearbeiteten Oberflächen, die Außenkante der Dichtringe, vorhandene Löcher in den Entlüftungsstopfen und das Typenschild beeinträchtigen.
- Wenn der Betrieb Stöße oder Überlastungen mit sich bringt, müssen Motorschutzrichtungen, Drehmomentbegrenzer, Sicherheitskupplungen usw. verwendet werden.
- Bei Getrieben, die im Freien installiert werden, ist ein geeigneter Schutz gegen direkte Witterungseinflüsse und Sonneneinstrahlung vorzusehen. Bei Installationen in feuchter Umgebung sind die bearbeiteten Oberflächen des Getriebes angemessen zu schützen.
- Aufgrund der hohen Temperaturen, die während des Betriebs auftreten können, wird der Einsatz von 2-poligen Motoren für den aussetzenden Betrieb empfohlen.
- Bei Umgebungstemperaturen zwischen -20°C und +40°C wenden Sie sich bitte an unseren technischen Service.



- Le couplage de l'arbre d'entrée creux du réducteur, est normalement effectué avec des pivots ayant une tolérance ISO h6; dans tous les cas le montage doit se faire sans forçages.
- S'assurer que le montage de pignons ou de poulies en porte-à-faux sur les arbres des réducteurs, soit conforme aux vérifications d'admissibilité des charges résultantes
- Vérifier, pour les réducteurs ayant un indicateur de niveau d'huile, que la position de ce dernier soit conforme à la position de montage du réducteur ; pour les réducteurs fournis avec le lubrifiant il est conseillé, lorsque l'installation est effectuée, de remplacer le bouchon fermé utilisé pour le transport, par le bouchon de purge fourni en équipement.
- Effectuer le premier remplissage ou l'éventuel remplissage de l'huile en faisant toujours référence à la ligne médiane du bouchon du niveau
- Les réducteurs fournis avec lubrification permanente ne nécessitent pas de cette procédure
- Avant la mise en service du réducteur, vérifier que la machine qui l'incorpore soit conforme aux dispositions de la Directive Machines 2006/42/CE et des mises à jour successives.
- Vérifier que la valeur de la tension d'alimentation gravée sur la plaque du moteur électrique coïncide à la tension de réseau
- La peinture ne doit absolument pas concerner les plans usinés, le bord extérieur des anneaux d'étanchéité, les trous existants sur les bouchons de purge, lorsqu'ils sont présents, et la plaque d'identification.
- Si le fonctionnement prévoit des chocs ou surcharges, il faut adopter des coupe-circuits, des limiteurs de couple, des joints de sécurité, etc.
- Pour les réducteurs installés à l'extérieur, prévoir des protections opportunes contre l'exposition directe aux agents atmosphériques et aux radiations solaires. Pour les installations dans des environnements humides, adopter les protections adéquates sur les surfaces usinées du réducteur
- L'utilisation des moteurs à 2 pôles est conseillée pour les services intermittents, à cause de la température élevée qui peut être enregistrée durant le fonctionnement
- En présence de températures ambiantes non comprises entre -20 °C et +40 °C contacter notre service technique.
- *El acoplamiento del eje de entrada hueco del reductor, normalmente se realiza con pernos con tolerancias ISO h6; y siempre se debe montar sin forzarlo*
- *Asegúrese de que el montaje de los piñones o de las poleas salientes, en los ejes de los reductores, cumpla con lo exigido en cuanto a admisibilidad de las cargas obtenidas*
- *Asegúrese de que la posición de este reductor con indicador de nivel sea conforme a la posición de montaje del reductor, para los reductores con lubricante se aconseja que cuando se haya instalado, se sustituya el tapón cerrado usado para el transporte, con una de purga que se suministra de fábrica.*
- *Efectuar el primer llenado o el llenado siguiente si es necesario del aceite, llenando siempre hasta la mitad del tapón de nivel.*
- *Los reductores con lubricación permanente no necesitan este procedimiento*
- *Antes de la puesta en servicio del reductor compruebe que la máquina que lo incorpora cumpla con las disposiciones de la Directiva de Máquinas 2006/42/CE y sus sucesivas actualizaciones.*
- *Compruebe que el valor de la tensión de alimentación marcada en la placa del motor eléctrico coincida con la tensión de red.*
- *La pintura no debe aplicarse nunca en las superficies de trabajo, el borde externo de los anillos de retención, los agujeros de los tapones de purga, si los lleva, ni en la placa de identificación.*
- *Si el funcionamiento incluye golpes o sobrecargas se deben usar guardamotors, limitadores de par, juntas de seguridad u otros elementos*
- *Para los reductores instalados en exteriores prepare las protecciones adecuadas contra la exposición directa a los agentes atmosféricos y a la radiación solar. Para instalaciones en ambientes con humedad, equipar con protecciones para las superficies en las que trabaja el reductor.*
- *El uso de los motores de 2 polos se recomienda para servicios intermitentes, debido a la elevada temperatura que se puede registrar mientras funciona.*
- *En caso de temperaturas ambiente que no se encuentren entre los -20°C y los +40°C consulte con nuestro servicio técnico.*
- O acoplamento do eixo de entrada oco do redutor normalmente é feito com pinos que possuem tolerâncias ISO h6; em qualquer caso, a montagem deve ser feita sem forçamentos
- Verificar se a montagem de pinhões ou de polias pendentes nos eixos das caixas de engrenagens está em conformidade com a verificação da admissibilidade das cargas resultantes
- Verificar, para os redutores com indicador de nível de óleo, se a posição deste último está em conformidade com a posição de montagem do redutor; para os redutores fornecidos com lubrificante recomenda-se, após efetuar a instalação, substituir o tampão fechado usado para o transporte, pelo tampão de alívio fornecido com o equipamento
- Realizar o primeiro enchimento, ou o eventual reabastecimento de óleo, sempre referindo-se ao centro do tampão do nível
- Os redutores fornecidos com lubrificação permanente não requerem este procedimento
- Antes da colocação em serviço do redutor, assegurar-se de que a máquina que o incorpora esteja em conformidade com as disposições da Diretiva 2006/42/EC Máquinas e atualizações sucessivas.
- Verificar se o valor da tensão de alimentação gravado na placa do motor elétrico coincide com a tensão de rede
- A pintura não deve afetar as superfícies usinadas, a borda externa dos anéis de vedação, os furos existentes nos tampões de alívio, quando presentes, e a placa de identificação
- Se o funcionamento envolver choques ou sobrecargas, deverão ser adotados protetores de motor, limitadores de binário, juntas de segurança, etc.
- Para os redutores instalados no exterior, fornecer proteções apropriadas contra a exposição direta aos agentes atmosféricos e à radiação solar. Para instalações em ambientes húmidos, adotar protetores apropriados nas superfícies usinadas do redutor
- O uso de motores de 2 polos é recomendado para serviços intermitentes, devido à alta temperatura que pode ser registada durante o funcionamento
- No caso de temperaturas do ambiente não compreendidas entre -20°C e +40°C, contactar o nosso serviço técnico.



Istruzioni per il serraggio del calettatore / Instructions for fitting the shrink disc

Anleitungen für den Anzug der Schrumpfscheibe

8

Tutta le serie dei riduttori pendolari Varmec è disponibile con albero lento cavo con calettatore, forma costruttiva S.

Durante il montaggio del riduttore sull'albero da azionare si devono seguire le seguenti operazioni:

1- Allentare gradualmente tutte le viti di serraggio facendo attenzione a non estrarle completamente dalle loro filettature e rimuovere il calettatore.

2- Le zone di accoppiamento fra l'albero lento del riduttore e l'albero della macchina da azionare devono essere pulite e sgrassate. Applicare sulle stesse una leggera pellicola d'olio.

3- Accoppiare l'albero condotto con il riduttore e successivamente montare il calettatore.

4- Serrare le viti in modo graduale ed uniforme con sequenza continua sino a raggiungere la coppia di serraggio Mt indicata in tabella.

Attenzione:

Non usare bisolfuro di molibdeno o altri grassi, causa di notevoli riduzioni del coefficiente d'attrito.

The entire series of Varmec gearboxes is available with hollow output shaft with shrink disc, construction shape S.

When installing the gearbox on the shaft to be operated, the following operations must be carried out:

1- Gradually loosen all the fixing screws, taking care not to remove them completely from their threads and remove the shrink disc.

2- The coupling areas between the gearbox output shaft and the shaft of the machine to be operated must be clean and degreased. Apply a thin coat of oil on them.

3- Couple the driven shaft with the gearbox and then assemble the shrink disc.

4- Tighten the screws gradually and evenly in a continuous sequence until reaching the tightening torque Mt indicated in the table.

Caution:

Do not use molybdenum disulphide or other greases, which cause a considerable reduction in the friction coefficient.

Sämtliche Varmec Aufsteckgetriebe sind mit langsamer Hohlwelle mit Spannsatz, Bauform S, erhältlich.

Bei der Montage des Getriebes auf der angetriebenen Welle sind die folgenden Schritte vorzunehmen:

1- Alle Klemmschrauben nach und nach lösen, dabei darauf achten, dass sie nicht ganz aus ihren Gewinden herausgezogen werden und den Spannsatz entfernen.

2- Die Kupplungsbereiche zwischen der langsamen Welle des Getriebes und der angetriebenen Welle der Maschine müssen gereinigt und entfettet werden. Eine hauchdünne Fettschicht auftragen.

3- Die angetriebene Welle an das Getriebe kuppeln und danach den Schrumpfscheibe wieder montieren.

4- Die Schrauben schrittweise und gleichmäßig in Folgesequenz anziehen, bis das in der Tabelle angegebene Anzugsdrehmoment Mt erreicht ist.

Achtung:

Kein Molybdändisulfid oder andere Fette verwenden, die zu einer starken Reduzierung des Reibungskoeffizienten führen.

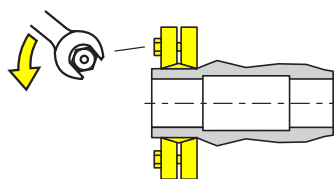

	RFV...FV									
	252	253	302	303	352	353	402	403	502	503
Mt [Nm]	8.5		14.5		14.5		14.5		14.5	



Toute la série des réducteurs pendulaires est disponible avec un arbre lent creux avec frette de serrage, forme de construction S. Durant le montage du réducteur sur l'arbre à actionner il faut suivre les opérations suivantes :

- 1- Desserrer graduellement toutes les vis de serrage en faisant attention à ne pas les extraire complètement de leurs filetages et enlever la frette de serrage.
- 2- Les zones de couplage entre l'arbre lent du réducteur et l'arbre de la machine à actionner doivent être nettoyées et dégraissées. Appliquer sur ces dernières une légère pellicule d'huile.
- 3- Coupler l'arbre du conduit avec le réducteur et ensuite monter la frette de serrage.
- 4- Serrer les vis en mode graduel et uniforme avec une séquence continue jusqu'à accéder au couple de serrage Mt indiqué dans le tableau.

Attention:

Ne pas utiliser de bisulfure de molybdène ou d'autres graisses qui peuvent causer d'importantes réductions du coefficient de frottement.

Toda la serie de reductores pendulares Varmec está disponible con eje lento hueco, con ensamblaje, forma constructiva en S. Mientras se monta el reductor en el eje que se debe accionar se deben ejecutar las operaciones siguientes:

- 1- Aflojar poco a poco todos los tornillos de apriete procurando no extraer completamente estos de las roscas ni quitar el ensamblaje.
- 2- Las zonas de acoplamiento entre el eje de crecimiento lento del reductor y el eje de la máquina que se debe accionar deben estar limpias y sin grasa. Aplicar una ligera capa de aceite.
- 3- Acoplar el eje conducido con el reductor y a continuación montar el ensamblaje.
- 4- Apretar los tornillos poco a poco y de manera uniforme con secuencia continua hasta que se alcance el par de apriete M indicado en la tabla.

Atención:

No usar bisulfuro de molibdeno ni otro tipo de grasas, puesto que provoca reducciones considerables del coeficiente de fricción.

Toda a série dos redutores pendulares da Varmec está disponível com eixo lento oco com disco de contração, forma construtiva em S. Durante a montagem do redutor no eixo que deve ser acionado, devem ser seguidas as operações abaixo:

- 1- Afrouxar gradualmente todos os parafusos de aperto prestando atenção para não removê-los completamente de suas roscas e remover o disco de contração.
- 2- As zonas de acoplamento entre o eixo "lento" do redutor e o eixo da máquina a ser acionada devem estar limpas e desengorduradas. Aplicar sobre elas uma fina camada de óleo.
- 3- Acoplar o eixo conduzido com o redutor e sucessivamente montar o disco de contração.
- 4- Apertar os parafusos de forma gradual e uniforme com a sequência contínua até atingir o binário de aperto Mt indicado na tabela.

Atenção:

Não usar dissulfeto de molibdênio ou outras graxas, pois ocorre uma redução significativa do coeficiente de atrito.

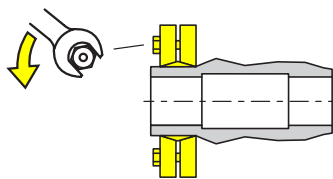

	RFV...FV									
	252	253	302	303	352	353	402	403	502	503
Mt [Nm]	8.5		14.5		14.5		14.5		14.5	



Manutenzione / Maintenance / Wartung

9

I riduttori forniti con lubrificazione permanente non necessitano di sostituzioni periodiche dell'olio.

Per gli altri tipi si consiglia di effettuare una prima sostituzione del lubrificante dopo le prime 300-500 ore di funzionamento, provvedendo ad un lavaggio interno prima del ripristino.

Evitare di miscelare oli sintetici con oli a base minerale.

Controllare periodicamente il livello del lubrificante effettuando la sostituzione indicativamente agli intervalli riportati nella tabella.

Gearboxes supplied with permanent lubrication do not require periodic oil changes.

For the other types it is advisable to replace the lubricant after the first 300-500 hours of operation, washing internally before filling.

Do not mix synthetic oils with mineral based oils.

Periodically check the level of lubricant, replacing it according to the intervals shown in the table.

Die Getriebe bis zu Größe 35 sind mit langlebigen synthetischem Öl gefüllt. Eine Wartung ist normalerweise nicht erforderlich.

Für die anderen Typen muss das Schmiermittel nach den ersten 300 bis 500 Betriebsstunden ausgetauscht werden. Vor dem Einfüllen sollte eine Innenreinigung durchgeführt werden.

Synthetische Öle dürfen nicht mit Mineralölen gemischt werden.

Den Schmiermittelfüllstand regelmäßig prüfen und den Austausch indikativ in den in der Tabelle angegebenen Zeitintervallen durchführen.

Temperatura olio Oil temperature Öltemperatur [C°]	Intervallo di lubrificazione / Lubrication frequency / Schmierintervall [h]	
	Olio minerale / Mineral oil / Mineralöl	Olio sintetico / Synthetic oil / Synthetisches Öl
< 60	8000	25000
60 - 80	4000	15000
80 - 95	2000	12500

10

Stoccaggio / Storage / Lagerung

Per un corretto stoccaggio dei riduttori ricevuti consigliamo di eseguire le seguenti raccomandazioni:

- Escludere aree all'aperto, zone esposte alle intemperie o con eccessiva umidità.
- L'ambiente deve essere sufficientemente pulito, esente da vibrazioni eccessive per non danneggiare i cuscinetti (tale necessità di contenere le vibrazioni deve essere soddisfatta anche durante il trasporto)
- Interporre sempre tra il pavimento e il riduttore, uno strato di isolante che impedisca il diretto contatto
- Disporre il riduttore in modo che abbia una base d'appoggio stabile ed accertarsi che non sussistano rischi di spostamenti imprevisti
- Ruotare semestralmente gli alberi di qualche giro per prevenire danneggiamenti a cuscinetti e anelli di tenuta
- Per periodi di stoccaggio superiori ai 60 giorni, le superfici interessate agli accoppiamenti devono essere protette con prodotti antiossidanti
- Per periodi di stoccaggio superiori ai 6 mesi, i riduttori dovranno avere le parti lavorate esterne e quelle di accoppiamento ricoperte di grasso per evitare ossidazioni, inoltre per i riduttori forniti privi di lubrificante dovranno essere riempiti di olio, posizionando il tappo di sfiato nella posizione più alta, e prima dell'utilizzo, riempiti con la corretta quantità e tipo di lubrificante previsto.

To ensure correct storage of the received gear reducer(s), please take note of the following recommendations:

- *Do not store outside, in areas exposed to bad weather or with excessive humidity.*
- *The ambient must be sufficiently clean and absent of any excessive vibrations that could damage the bearings – this is also true for transportation*
- *Always place some kind of isolating material between the floor and the gear reducer so that there is no direct contact.*
- *Make sure that the gear reducer is on a stable base and cannot be accidentally knocked or moved*
- *Give the shafts a few turns every six months to prevent damage to bearings and oil seals*
- *For storage periods of over 60 days coupling surfaces must be protected with an anti-oxidant*
- *For storage periods of longer than 6 months all external working parts and coupling parts must be greased to avoid oxidation. Take note that reducers supplied without lubricant should be filled up with oil and the breather plug should be in its highest position. Before first use the gear reducer must be filled with the correct type and quantity of required lubricant.*

Beachten Sie bitte folgendes, um die gelieferten Getriebe richtig zu lagern:

- Nicht im Freien lagern.
- Die Umgebung muß ausreichend sauber sein
- Keine zu starken Vibrationen, damit die Lager nicht beschädigt werden (dies gilt auch für den Transport)
- Um direkten Bodenkontakt zu vermeiden, sollte die Lagerung immer auf einer isolierenden Unterlage erfolgen
- Stellen Sie sicher, daß das Getriebe auf einer stabilen und sicheren Unterlage gelagert ist und keinen unvorhergesehenen Stößen bzw. Bewegungen ausgesetzt ist
- Mindestens alle 6 Wochen sollten die Wellen bewegt werden, damit die Lager und die Dichtungsringe nicht einrostern
- Bei Lagerzeiten über 60 Tagen sollten alle bearbeiteten Flächen mit einem Rostschutzmittel behandelt werden
- Bei Lagerzeiten über 6 Monaten sollten alle bearbeiteten Flächen eingefettet werden, um Rostbildung zu vermeiden
- Zudem muß bei den Getrieben, die ohne Schmieröl geliefert werden, das Öl wieder aufgefüllt werden. Hierzu wird das Entlüftungsventil auf die höchste Position eingestellt. Vor dem ersten Gebrauch sollte das Schmieröl nochmals auf die korrekte Menge und die richtige Typenart überprüft werden



Les réducteurs fournis avec la lubrification permanente ne nécessitent pas de remplacements périodiques de l'huile.

Pour les autres types, il est conseillé d'effectuer un premier remplacement du lubrifiant après les 300-500 premières heures de fonctionnement, en procédant à un lavage à l'intérieur avant le rétablissement.

Éviter de mélanger des huiles synthétiques avec des huiles à base minérale.

Contrôler périodiquement le niveau du lubrifiant en effectuant le remplacement approximativement aux intervalles reportés dans le tableau.

No es necesario reponer aceite periódicamente en los reductores con lubricación permanente.

Para los demás tipos se recomienda efectuar una primera sustitución del lubricante al cabo de las primeras 300-500 horas de funcionamiento, lavando por dentro antes del restablecimiento.

Evite mezclar aceites sintéticos con otros de base mineral.

Controlar periódicamente el nivel del lubricante sustituyendo de forma indicativa con los intervalos indicados en la tabla.

Os redutores fornecidos com lubrificação permanente não requerem substituições periódicas de óleo.

Para os outros tipos é aconselhável fazer uma primeira substituição do lubrificante após as primeiras 300-500 horas de funcionamento, fazendo uma lavagem interna antes do restabelecimento.

Não misturar óleos sintéticos com óleos minerais.

Controlar periodicamente o nível do lubrificante, substituindo-o de acordo com os intervalos indicados na tabela.

Température de l'huile Temperatura del aceite Temperatura do óleo [C°]	Intervalle de lubrification / Intervalo de lubricación / Intervalo de lubrificação [h]	
	Huile minérale / Aceite mineral / Óleo mineral	Huile synthétique / Aceite sintético / Óleo sintético
< 60	8000	25000
60 - 80	4000	15000
80 - 95	2000	12500

Observer les instructions suivantes afin de conserver en l'état la livraison des matériels:

- Ne pas stocker à l'extérieur, des locaux exposés au mauvais temps ou avec une humidité excessive
- Le milieu doit être suffisamment propre, sans vibrations excessive pour ne pas endommager les roulements (la nécessité de limiter les vibrations doit être satisfaite pendant le transport aussi)
- Interposer toujours entre le sol et le réducteur une couche isolante
- Le réducteur doit avoir une base d'appui stable et vérifier l'absence de risques de déplacement inprevus
- Tourner tous les 6 mois les arbres pour prévenir des dommages aux roulements et aux bagues d'étanchéité
- Pour un stockage d'une période supérieure à 60 jours, toutes les surfaces d'acouplement doivent être protégées avec un produit anti-oxydation
- Pour un stockage d'une période supérieure à 6 mois, toutes les parties externes et les surfaces d'acouplement doivent être graissées afin d'éviter l'oxydation. De plus, les réducteurs fournis sans lubrifiant doivent être entièrement remplis, et le bouchon d'évent positionné en haut. Lors de la mise en utilisation des réducteurs, vidanger ceux-ci jusqu'à la quantité recommandée.

Para un correcto almacenamiento de los reductores aconsejamos seguir las siguientes recomendaciones:

- *Excluir áreas abiertas, zonas expuestas a la interperie o con excesiva humedad*
- *El ambiente debe ser suficientemente limpio, ausente de vibraciones excesivas para no dañar los cojinetes (tal necesidad de contener las vibraciones debe ser presente durante el transporte)*
- *Interponer siempre entre el piso y el reductor un estrato de pintura aislante que impida el contacto directo*
- *Disponer el reductor de manera que tenga una base de apoyo estable y asegurarse que no existan riesgos de imprevistos imprevistos*
- *Rotar semestralmente los ejes de cualquier giro para prevenir daños a cojinetes y retenes herméticos*
- *Para periodos de almacenamientos superiores a los 60 días, las superficies interesadas en los acoplamientos deben ser protegidas con productos antioxidantes*
- *Para periodos de almacenamiento superiores a 6 meses, los reductores tendrán que tener las partes laboradas externas y las de acoplamiento cubiertas de grasa para prevenir oxidaciones y los reductores sin lubricante tendrán que ser llenados de aceite poniendo el tapón respiradero en la posición más alta, y antes de la utilización deben ser llenados con la correcta cantidad y tipo de lubricante previsto*

Para uma correta armazenagem de redução recebida, aconselhamo de seguire a seguinte recomendação:

- Não estar em aréa aberta, e nem em lugar úmido.
- O ambiente deve ser suficientemente limpo. Não deve ter vibração para não quebrara o custinete (tal necessidade de conter a vibração deve ser satisfeita também durante o transporte)
- Colocar sempre no chão o ridutor, uma estrato de isolante que impedi o direto contato.
- Coloque a redução em modo que haja uma base de apoio estavel e tenha certeza que não aconteça risco de afasamento imprevisto
- Girando semestralmente o eixo de qualquer giro para previnir estragos no parafusos e anel de segurança
- Para o período de armazenagem superior ao 60 dia, a superfície interessado ao acoplamento devem ser protegido com produto anti-ossidante
- Para período de armazenagem superior a 6 meses o ridutor devem ter a parte trabalhada externa e aquele de acoplamento coberto de graxa para evitar ossidação, o ridutor não contém olio lubrificante e deve ser cheio de olio. Posicionando o tampão de respração na posição mais alta, e antes do utilizo encher com a correta quantidade e tipo de lubrificante previsto.



Condizioni di fornitura / Conditions of supply / Lieferbedingungen

11

I riduttori Varmec vengono forniti come segue:

- Già predisposti per essere installati nella posizione di montaggio come definito in fase di ordine
- Collaudati secondo specifiche interne
- Le superfici di accoppiamento non sono verniciate
- Sprovvisi di dadi e bulloni per il montaggio motori per la versione IEC
- Appositamente imballati per la spedizione.

All Varmec gear reducers are supplied as follows:

- *Ready made to be installed in the assembly position previously stated during ordering*
- *Tried and tested to our internal specifications*
- *Coupling surfaces are not varnished*
- *Nuts and bolts are not supplied for the assembly of motors for IEC versions*
- *Appropriately and adequately packaged for transport.*

Die Varmec Getriebe werden wie folgt ausgeliefert:

- Vorbereitet zum Einbau in die bestellte Einbaulage (die beigefügten Ventile und Entlüftungen müssen ggf. noch eingebaut werden)
- Nach internen Vorgaben überprüft
- Keine Lackierung der Oberflächenverbindungen
- Die Version IEC enthält keine Schrauben und Muttern für die Montage des Motors.



Conditions de fourniture / Condiciones de suministro / Condições de fornecimento

Les réducteurs Varmec sont fournis comme suit:

- Déjà prêts à l'installation dans la position de montage comme indiqué dans la commande
- Eprouvés suivant spécifications internes
- Les surfaces d'accouplement ne sont pas vernies
- Dépourvus d'écrous et boulons pour le montage moteurs pour la version IEC
- Emballage express pour la livraison

Los reductores VARMEC vienen equipados de la siguiente manera:

- *Listos para ser instalados en la posición de montaje descrita en el pedido*
- *Aprobados segun normas internas*
- *La superficie de los acoples no son barnizadas*
- *Desprovistos de tuercas y tornillos para el montaje del motor IEC*
- *Adecuadamente embalados para la expedición.*

O ridutor Varmec vem fornido com o segue:

- É predisposto para ser instalado
- Laudo segundo especificado interno
- A superfície de acoplamento não são vernizadas
- Não tem parafuso e porca para a montagem do motor, para a versão IEC
- Apositamente embalado para a expedição

11



Caratteristiche costruttive / Construction features / Baumerkmale

12

I riduttori e i motoriduttori VARMEC sono stati progettati interamente con l'ausilio di programmi tecnici su computer.

Ogni singolo componente è stato verificato e progettato tenendo conto del massimo carico applicabile al riduttore secondo normativa AGMA 2001-B88 rispettando le caratteristiche di modularità.

Casse e flange in alluminio non verniciato nelle grandezze 252-253, 302-303, casse e flange in ghisa ad alta resistenza verniciate nelle altre grandezze. La forma monolitica delle casse conferisce ai riduttori un'ottima rigidità ed una elevata compattezza e ne permette l'utilizzo in tutte le posizioni di montaggio possibili.

Le lavorazioni dei vari componenti avvengono su moderni centri di lavoro a controllo numerico che permettono di ottenere la massima precisione costruttiva.

Tutti gli ingranaggi sono costruiti con acciaio legato, cementati e temprati con successiva lavorazione di rettifica sui fianchi dei denti per migliorarne il rendimento e la silenziosità di funzionamento anche sotto carico. Valori indicativi massimi di livello sonoro 75dB.

L'albero ingresso è realizzato con acciaio legato, cementato e temprato; quello in uscita con acciaio bonificato.

I riduttori vengono verniciati con una polvere termoindurente a base di resine poliesteri, modificate con resina epossidica, colore Blu Bucciato RAL5010.

Maggiori informazioni sulle specifiche della vernice potranno essere richieste al nostro Ufficio Tecnico.

VARMEC gearboxes and gearmotors have been designed entirely with the aid of technical computer programs. Every single component has been checked and designed taking into account the maximum load applicable to the gearbox according to the AGMA 2001-B88 regulation, in compliance with the modularity characteristics.

Casings and flanges are made of unpainted aluminium in sizes 252-253, 302-303, while the casings and flanges made of high resistance cast-iron are painted in the other sizes. The rounded shape of the casings gives the gearboxes excellent rigidity and solidity and allows them to be used in all possible assembly positions.

The various components are processed on modern CNC machinery, ensuring maximum constructive precision.

All gears are made of alloyed, hardened and tempered steel with subsequent grinding on the sides of the teeth to improve performance and silent operation even under load. Approximate maximum sound level values 75dB.

The input shaft is made of alloyed, cemented and hardened steel; the output shaft is made of reclaimed steel.

The gearboxes are painted with a polyester resin-based thermosetting powder, modified with epoxy resin, in RAL5010 Textured Blue.

More information on the paint specifications can be requested from our Technical Department.

Die Getriebe und Getriebemotoren VARMEC wurden vollständig mit Hilfe von technischen Computerprogrammen entwickelt. Jede einzelne Komponente wurde unter Berücksichtigung der maximalen Belastung des Getriebes gemäß AGMA 2001-B88 unter Berücksichtigung der modularen Eigenschaften geprüft und ausgelegt.

Gehäuse und Flansche aus unlackiertem Aluminium in den Größen 252-253, 302-303, Gehäuse und Flansche aus hochfestem Gusseisen in anderen Größen. Die monolithische Bauweise der Gehäuse verleiht den Getrieben eine hervorragende Steifigkeit und Kompaktheit und ermöglicht den Einsatz in allen möglichen Montagepositionen. Die verschiedenen Komponenten werden auf modernen numerisch gesteuerten Bearbeitungszentren bearbeitet, die eine extrem präzise Fertigung ermöglichen.

Alle Zahnräder sind aus legiertem Stahl gefertigt, zementiert und gehärtet mit anschließendem Schleifen der Zahnflanken, um die Leistung und die Geräuschlosigkeit des Betriebs auch unter Last zu verbessern. Indikative Höchstwerte des Geräuschpegels 75dB.

Die Eingangswelle ist aus Legierungsstahl, zementiert und gehärtet; die Ausgangswelle aus vergütetem Stahl.

Die Getriebe sind mit einem duroplastischen Pulver auf Polyesterharzbasis lackiert, modifiziert mit Epoxidharz, Farbe Blau Bucciato RAL5010.

Genauere Informationen über den Lack erhalten Sie von unserer technischen Abteilung.

13 Forme costruttive / Construction shapes / Bauformen

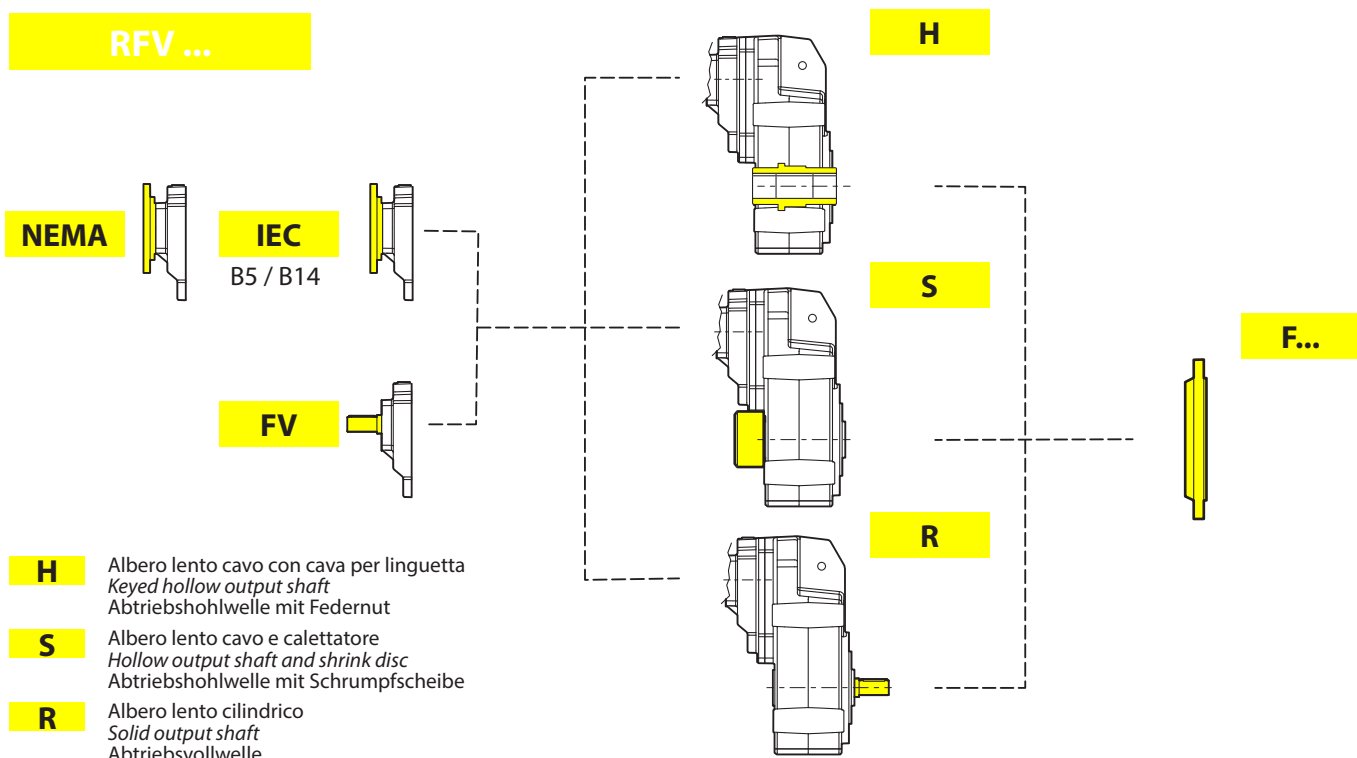



Les réducteurs et les motorréducteurs VARMEC ont été conçus entièrement à l'aide de programmes techniques sur ordinateur.

Chaque composant a été vérifié et conçu en tenant compte de la charge maximum applicable au réducteur selon la réglementation AGMA 2001-B88 en respectant les caractéristiques de modularité.

Caisses et brides en aluminium non peint dans les tailles 252-253, 302-303, caisses et brides en fonte à haute résistance peintes dans les autres tailles. La forme monolithique des caisses procure aux réducteurs une rigidité parfaite et une compacité élevée et en permet l'utilisation dans toutes les positions de montage possibles.

Les usinages des divers composants se font sur des centres de travail modernes à contrôle numérique qui permettent d'obtenir une précision de construction maximale. Tous les engrenages sont construits avec de l'acier allié, cimentés et trempés avec l'usinage successif de rectification sur les côtés des dents pour en améliorer le rendement et le caractère silencieux de fonctionnement même avec charge. Valeurs indicatives maximales de niveau sonore 75 dB.

L'arbre entrée est réalisé avec de l'acier allié, cimenté et trempé ; celui en sortie avec de l'acier bonifié.

Les réducteurs sont peints avec une poudre thermodurcissable à base de résines polyester, modifiées avec de la résine époxy, couleur Blu Bucciato RAL5010.

Plus d'informations sur les spécifications de la peinture pourront être demandées à notre Bureau Technique.

Los reductores y los motorreductores VARMEC se han diseñado por dentro con programas técnicos basados en programas de ordenador. Cada componente se ha comprobado y diseñado considerando la carga máxima aplicable al reductor, según la normativa AGMA 2001-B88 respetando las características de modularidad.

Cajas y bridas de aluminio sin pintar de tamaño 252-253, 302-303, cajas y bridas de fundición de alta resistencia pintadas en otros tamaños. La forma monolítica de las cajas aporta una excelente rigidez a los reductores y un alto nivel de compacidad y permite que se usen en todas las posiciones posibles de montaje.

Las elaboraciones de los diferentes componentes se producen en centros de mecanizado modernos, con control numérico, que permiten la máxima precisión de fabricación.

Todos los engranajes se han fabricado con aleación de acero, cementados y templados con la sucesiva elaboración de rectificado en los lados de los dientes, para mejorar el rendimiento y para que el funcionamiento incluso bajo carga, sea lo más silencioso posible. Valores indicativos máximos de nivel sonoro 75dB.

El eje de entrada se ha fabricado con acero aleado, cementado y templado, el de salida en acero bonificado.

Los reductores se pintan con polvo de endurecimiento termoestable a base de resinas de poliéster modificadas con resina epoxi de color Azul Genciana RAL5010.

Se puede solicitar más información sobre las especificaciones de la pintura a nuestro Departamento Técnico.

Os redutores e os motorreductores VARMEC foram projetados inteiramente com a ajuda de programas técnicos em computadores.

Cada componente foi verificado e projetado tendo em conta a carga máxima aplicável ao redutor de acordo com as regulamentações AGMA 2001-B88, respeitando as características de modularidade.

Caixas e flanges de alumínio não pintado nos tamanhos 252-253, 302-303, caixas e flanges de ferro fundido de alta resistência pintado nos outros tamanhos. A forma monolítica das caixas dá aos redutores uma excelente rigidez e alta compacidade, o que permite que eles sejam usados em todas as possíveis posições de montagem.

Os processamentos dos vários componentes são feitos em modernos centros de usinagem com controlo numérico que permitem obter a máxima precisão construtiva.

Todas as engrenagens são feitas com aço de liga, cimentados e temperados com sucessivo processo de retificação nos lados dos dentes para melhorar o seu desempenho e o silêncio do funcionamento mesmo com carga. Valores indicativos máximos de nível sonoro 75dB.

O eixo de entrada é feito com aço de liga, cimentado e temperado; o de saída com aço beneficiado.

Os redutores são pintados com um pó termoendurecível à base de resinas de poliéster, modificadas com resina epoxídica, na cor Azul Genciana RAL5010.

Mais informações sobre as especificações da pintura podem ser solicitadas ao nosso Departamento Técnico.

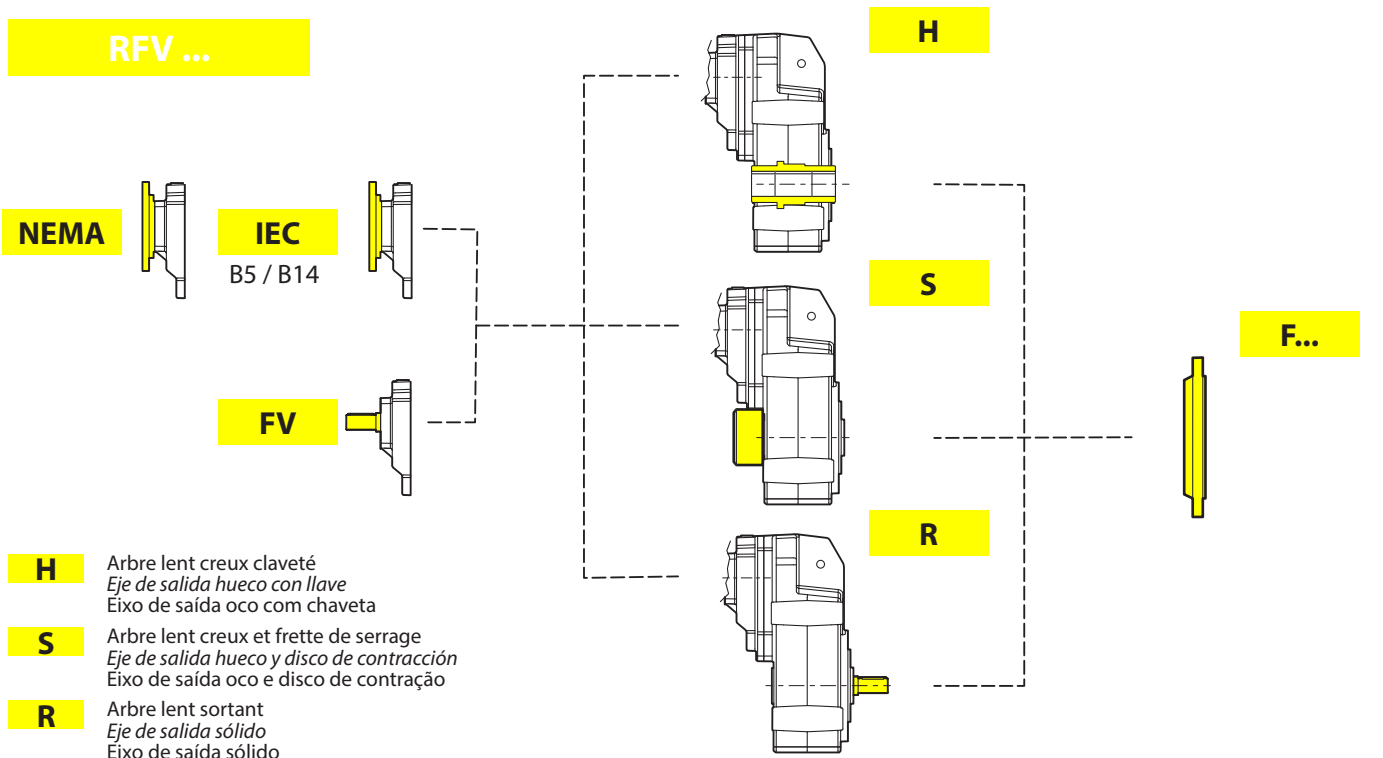



RIDUTTORE / GEAR REDUCER / GETRIEBE / REDUCTEUR / REDUCTOR / RIDUTOR

RFV	35	3	H35	110.69	F200	IEC 90B5	H1	...
------------	-----------	----------	------------	---------------	-------------	-----------------	-----------	------------

RFV

TIPO DI RIDUTTORE
TYPE OF GEAR REDUCER
GETRIEBETYPEN
TYPE DE REDUCTEUR
TIPO DE REDUCTOR
TIPO DE RIDUTOR

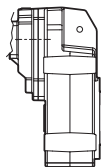

35

GRANDEZZA
SIZE
GETRIEBEGRÖSSEN
TAILLE
TAMANO DEL REDUCTOR
GRANDEZA

25, 30, 35, 40, 50

3

N° STADI DI RIDUZIONE
N. OF STAGES OF REDUCTION
ANZAHL DER UNTERSETZUNGEN
N.° STADES DE REDUCTION
N° ESTADOS DE REDUCCION
N° DE PARTE DE REDUÇÃO

2, 3

H35

FORMA COSTRUTTIVA
STRUCTURAL SHAPE
BAUFORM
FORME CONSTRUCTIVE
FORMA CONSTRUCTIVA
FORMA CONSTRUTIVA

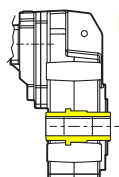

H...

F25..		F30..		H ..		F40..		F50..	
H25	H30	H35	H40	H45	H50	H55	H60	H2"	H2"
H24	H30	H35	H40	H45	H50	H55	H60	H2"	H2"
H30	H1 1/4"	H1 3/8"	H1 1/2"						

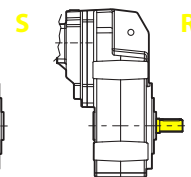
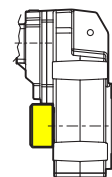

110.69

RAPPORTO DI RIDUZIONE
REDUCTION RATIO
UNTERSETZUNGSVERHÄLTNIS
RAPPORT DE REDUCTION
RELACION DE REDUCCION
RAZÃO DE REDUÇÃO

F200

FLANGIA DI USCITA
OUTPUT FLANGE
ABTRIEBSFLANSCH
BRIDA DE SORTIE
BRIDA DE SALIDA
FLANGE DE SAIDA

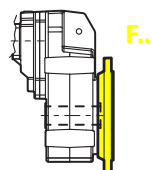
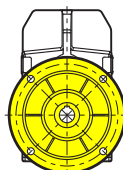

IEC 90B5

TIPO DI ENTRATA
TYPE OF INPUT
EINTRIEBSARTEN
TYPE D'ENTREE
TIPO DE ENTRADA
TIPO DE ENTRADA



IEC
B5/B14

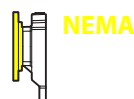

NEMA

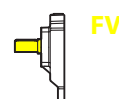

FV

H1

POSIZIONE DI MONTAGGIO
ASSEMBLY POSITION
EINBAUPOSITION
POSITION DE MONTAGE
POSICION DE MONTAJE
POSIÇÃO DE MONTAGEM



31

...

OPZIONI
OPTIONS
SONDERAUSFÜHRUNGEN
OPTIONS
OPCIONES
OPÇÃO



27



Opzioni riduttori

- AV** Anelli di tenuta in entrata e uscita in Viton.
 - EV** Anelli di tenuta in entrata in Viton
 - EX** Riduttore in versione Atex.
 - OA** I riduttori sono forniti con olio lubrificante alimentare.
 - OS** I riduttori della serie RFV 502-503 solitamente sprovvisti di lubrificante, vengono forniti con olio sintetico.
 - SO** I riduttori dalla serie RFV 25... a RFV 40..., solitamente forniti con lubrificante da VARMEC, sono forniti privi di lubrificante.
 - FL** Lavorazione aggiuntiva di spianatura e foratura laterale.
 - AR** Cuscinetti rinforzati sull'albero lento.
 - ME** Riduttore con motore elettrico (specificare le caratteristiche del motore elettrico).
 - CT** Coperchio di tenuta
- ACCESSORI v. pag. 88**

Options réducteurs

- AV** Bagues d'étanchéité en entrée et sortie en Viton
 - EV** Bagues d'étanchéité en entrée Viton.
 - EX** Réducteur en version Atex.
 - OA** Les réducteurs sont fournis avec de l'huile lubrifiante alimentaire
 - OS** Les réducteurs de la série RFV 502-503 en général sans lubrifiant, sont fournis avec de l'huile synthétique.
 - SO** Les réducteurs de la série RFV 25... à RFV 40..., fournis en général avec le lubrifiant par VARMEC, sont fournis sans lubrifiant.
 - FL** Usinage supplémentaire de dégauchissage et de perçage latéral.
 - AR** Roulements renforcés sur l'arbre lent.
 - ME** Réducteur avec moteur électrique (spécifier les caractéristiques du moteur électrique).
 - CT** Couvercle d'étanchéité
- ACCESSOIRES v. page 88**

Gear reducer options

- AV** Viton input and output oil seals.
- EV** Viton input oil seals.
- EX** Gearbox in Atex version.
- OA** The gearboxes are supplied with food-grade lubricating oil.
- OS** The gearboxes of the RFV 502-503 series, usually supplied without lubricant, are supplied with synthetic oil.
- SO** The gearboxes of the RFV 25... to RFV 40... series, usually supplied with lubricant by VARMEC, are supplied without lubricant.
- FL** Additional smoothing and side drilling.
- AR** Reinforced bearings on the output shaft.
- ME** Gearbox with electric motor (specify the characteristics of the electric motor).
- CT** Sealing cover

ACCESSORIES see page 88

Opciones de los reductores

- AV** Anillos de retención en entrada y salida de Viton.
- EV** Anillos de retención en entrada de Viton
- EX** Reductor en versión Atex.
- OA** Los reductores se suministran con aceite lubricante alimentario.
- OS** Los reductores de la serie RFV 502-503 normalmente sin lubricante, se suministran con aceite sintético.
- SO** Los reductores de la serie RFV 25... a la RFV 40..., normalmente suministrados con lubricante de la empresa VARMEC, se suministran sin lubricante.
- FL** Elaboración adicional de refrentado y perforación lateral.
- AR** Cojinetes reforzados en el eje lento.
- ME** Reductor con motor eléctrico (especificar las características del motor eléctrico).
- CT** Cubierta de sellado

ACCESORIOS v. pag. 88

Optionen für die Getriebe

- AV** Viton-Dichtungsringe am Ein- und Ausgang.
 - EV** Viton-Dichtungsringe am Eingang.
 - EX** Getriebe in Atex-Ausführung.
 - OA** Die Getriebe werden mit Lebensmittel-schmieröl geliefert.
 - OS** Die Getriebe der Baureihe RFV 502-503, meist ohne Schmierung, werden mit synthetischem Öl geliefert.
 - SO** Die Getriebe der Baureihe RFV 25.... nach RFV 40....., von VARMEC üblicherweise mit Schmiermittel versehen, werden ohne Schmiermittel geliefert.
 - FL** Zusätzlich seitliche Bearbeitung durch Schleifen und Bohren.
 - AR** Kugellagerverstärkung auf der langsamen Welle.
 - ME** Getriebe mit Elektromotor (die Eigenschaften des Elektromotors angeben).
 - CT** Dichtungsdeckel
- ZUBEHÖR s. Seite 88**

Opções para redutores

- AV** Anéis de vedação na entrada e na saída de Viton.
- EV** Anéis de vedação na entrada de Viton.
- EX** Redutor na versão Atex.
- OA** Os reductores são fornecidos com óleo lubrificante alimentar.
- OS** Os reductores da série RFV 502-503 normalmente desprovidos de lubrificante, são fornecidos com óleo sintético.
- SO** Os reductores da série RFV 25... a RFV 40..., normalmente fornecidos com lubrificante pela VARMEC, são fornecidos sem lubrificante.
- FL** Usinagem adicional de aplainamento e furação lateral.
- AR** Rolamentos reforçados no eixo lento.
- ME** Redutor com motor elétrico (especificar as características do motor elétrico).
- CT** Tampa de vedação

ACESSÓRIOS v. pag. 88

MOTORE / MOTOR / MOTOREN / MOTEUR / MOTOR / MOTOR

T 80A 4 230/400 50 CLF A

T	TIPO MOTORE / TYPE OF MOTOR / MOTORTYP TYPE MOTEUR / TIPO DE MOTOR / TIPO DE MOTOR
80A	GRANDEZZA / SIZE / GRÖSSE TAILLE / TAMANO / GRANDEZA
4	N° POLI / N. OF POLES / ANZAHL DER POLE N.° POLES / N° POLOS / N° PÓLO
230/400	TENSIONE / VOLTAGE / SPANNUNG TENSION / TENSION / TENSÃO
50	FREQUENZA / FREQUENCY / FREQUENZ FREQUENCE / FRECUENCIA / FREQUÊNCIA
CLF	CLASSE ISOLAMENTO / INSULATION CLASS / ISOLATIONSKLASSE CLASSE ISOLEMENT / CLASE DE AISLAMIENTO / CLASSE ISOLAMENTO
IP55	PROTEZIONE / PROTECTION / SCHUTZ PROTECTION / PROTECCION / PROTEÇÃO
A	POSIZIONE MORSETTIERA / POSITION OF TERMINAL BOX / POSITION DER KLEMMLEISTE POSITION BARRETTE DE CONNECTION / POSICION DE LA CAJA DE BORNES / POSIÇÃO
....	OPZIONI / OPTIONS / SONDERAUSFÜHRUNGEN OPTIONS / OPCIONES / OPÇÃO

T trifase **TF** trifase autofrenante **M** monofase **MF** monofase autofrenante
T tri-phase **TF** self-locking tri-phase **M** monophase **MF** self-locking monophase
T Drehstrommotor **TF** Drehstrom-Bremsmotor **M** Einphasenmotor **MF** Einphasen-Bremsmotor
T triphasé **TF** triphasé auto **M** monophasé **MF** monophasé auto
T trifásico - **TF** trifásico autofrenante - **M** monofásico - **MF** monofásico autofrenante
T motor eléctrico trifásico **TF** motor eléctrico trifásico autofrenante **M** motor monofásico
MF motor monofásico autofrenante



Tutti i riduttori di produzione VARMEC sono previsti con lubrificazione ad olio sintetico.

- I riduttori dalla grandezza RFV 25.. alla RFV 40.. sono forniti con lubrificante dalla fabbrica. Questi riduttori non richiedono sostituzioni periodiche del lubrificante per tutto l'arco della loro vita.
- I riduttori della serie RFV 502-503 vengono normalmente forniti sprovvisti di lubrificante, se non specificato nell'ordine, e sarà cura del cliente immettere, prima della messa in esercizio, la giusta quantità di olio lubrificante.

A tal proposito i riduttori sono muniti dei tappi di carico, scarico e livello olio; per i riduttori forniti completi di lubrificante si raccomanda, effettuata l'installazione, di sostituire il tappo chiuso, utilizzato per il trasporto, con il tappo di sfiato fornito a corredo.

Al fine di predisporre il corretto orientamento dei tappi, per una adeguata lubrificazione consigliamo di precisare sempre la posizione di montaggio desiderata. Nelle posizioni di montaggio che prevedono i riduttori con un asse verticale (H5, H6), dove lo sbattimento dell'olio durante il funzionamento non sarebbe sufficiente a garantire la corretta lubrificazione dei cuscinetti superiori, vengono montati dei cuscinetti autolubrificanti del tipo 2RS.

Per il corretto riempimento del riduttore si dovrà fare riferimento tassativamente alla mezzeria del tappo di livello.

Rispetto a questa condizione la quantità di lubrificante riportata nella tabella 5 può presentare degli scostamenti.

Il funzionamento dei riduttori è ammesso per temperature ambientali comprese tra -20°C e +40°C.

Per temperature ambientali comprese tra -20°C e -10°C l'avviamento del riduttore potrà avvenire solo dopo aver effettuato un pre-riscaldamento progressivo ed omogeneo del gruppo oppure con funzionamento "a vuoto", senza carico collegato.

Il carico potrà poi essere applicato all'albero del riduttore quando la temperatura dello stesso avrà raggiunto la temperatura di -10°C o superiore.

All gearboxes manufactured by VARMEC are designed with synthetic oil lubrication.

- *Gearboxes from size RFV 25.. to RFV 40.. are supplied with lubricant from the factory. These gearboxes do not require periodic lubricant replacement throughout their service life.*
- *The gearboxes of the RFV 502-503 series are normally supplied without lubricant, if not specified in the order, and it is the customer's responsibility to introduce the correct amount of lubricating oil before commissioning.*

In this regard, the gearboxes are fitted with filler caps, drain and oil level plugs; for gearboxes supplied with lubricant it is recommended, after installation, to replace the closed plug used for transport, with the breather plug provided.

In order to fit the plugs with the correct orientation, it is recommended to always specify the desired assembly position for proper lubrication. In the assembly positions that feature gearboxes with a vertical axis (H5, H6), where the oil splashing during operation would not be enough to ensure proper lubrication of the upper bearings, type 2RS self-lubricating bearings are fitted.

To fill the gearbox properly, refer to the centre-line of the level plug.

With respect to this condition, the quantity of lubricant shown in table 5 may feature deviations.

The operation of the gearboxes is permitted for ambient temperatures ranging between -20°C and +40°C.

For ambient temperatures ranging between -20°C and -10°C the gearbox can only be started after a progressive and homogeneous pre-heating of the unit or in "no-load" operating conditions, without any load connected. The load can then be applied to the shaft of the gearbox when the temperature of the same reaches a temperature of -10°C or higher.

Alle von VARMEC hergestellten Getriebe sind für die Schmierung mit synthetischem Öl ISO VG 320 vorgesehen.

- Alle Getriebe der Größe RFV 25.. bis RFV 40.. werden mit werksseitiger Schmierung geliefert. Diese Getriebe bedürfen lebenslang keines regelmäßigen Wechsels des Schmiermittels.
- Die Getriebe der Serie RFV 502-503 werden in der Regel ohne Schmierung geliefert, sofern nicht anders in der Bestellung angegeben, und es obliegt dem Kunden, vor der Inbetriebnahme die korrekte Menge an Schmieröl einzugeben.

Zu diesem Zweck sind die Getriebe mit Öleinfüll- und Ablassschrauben sowie Füllstandanzeigen ausgestattet; bei Getrieben, die komplett mit Schmiermittel geliefert werden, wird empfohlen, nach der Installation den geschlossenen, für den Transport verwendeten Stopfen durch den mitgelieferten Entlüftungsstopfen zu ersetzen.

Für eine korrekte Schmierung empfehlen wir, immer die gewünschte Montageposition anzugeben, damit die Verschlüsse ordnungsgemäß ausgerichtet werden können. In den Montagepositionen für Getriebe mit vertikaler Achse (H5, H6), bei denen eine Ölspritzung während des Betriebs nicht ausreicht, sind selbstschmierende Lager des Typs 2RS eingebaut, um eine korrekte Schmierung der oberen Lager zu gewährleisten.

Für die korrekte Befüllung des Getriebes ist es unabdingbar, sich auf die Mitte der Füllstandanzeige zu beziehen.

Hinsichtlich dieser Bedingung kann die in Tabelle 5 angegebene Schmierstoffmenge andere Werte aufweisen.

Der Betrieb der Getriebe ist in Räumen mit einer Temperatur zwischen -20°C und +40°C zulässig.

In Räumen, in denen eine Temperatur zwischen -20°C und -10°C herrscht, muss vor Starten des Getriebes das Aggregat progressiv und gleichmäßig vorerwärmt werden, oder im „Leerbetrieb“ ohne angeschlossene Last erwärmt werden.

Die Last kann dann auf die Getriebewelle aufgebracht werden, wenn diese -10°C oder eine höhere Temperatur erreicht hat.



Tous les réducteurs de production VARMEC sont prévus avec une lubrification à l'huile synthétique.

- Les réducteurs de la taille RFV 25.. à la RFV 40.. sont fournis avec le lubrifiant par l'usine. Ces réducteurs ne nécessitent pas de remplacements périodiques du lubrifiant pendant toute leur durée de vie.
- Les réducteurs de la série RFV 502-503 sont fournis normalement sans lubrifiant, si ce n'est pas spécifié dans la commande, et ce sera au soin du client d'introduire, avant la mise en fonction, la bonne quantité d'huile de lubrification.

À ce propos les réducteurs sont munis de bouchons de remplissage, de vidange et de niveau d'huile ; pour les réducteurs fournis avec le lubrifiant il est conseillé, lorsque l'installation est effectuée, de remplacer le bouchon fermé, utilisé pour le transport, par le bouchon de purge fourni en équipement.

Afin de prévoir l'orientation correcte des bouchons, pour une lubrification adéquate, nous conseillons de toujours préciser la position de montage souhaitée. Dans les positions de montage qui prévoient les réducteurs avec un axe vertical (H5, H6), où l'agitation de l'huile durant le fonctionnement ne suffirait pas à garantir la lubrification correcte des roulements supérieurs, sont montés des roulements autolubrifiants du type 2RS.

Pour le remplissage correct du réducteur il faudra faire référence impérativement à la ligne médiane du bouchon de niveau.

Par rapport à cette condition la quantité de lubrifiant reportée dans le tableau 5 peut présenter des écarts.

Le fonctionnement des réducteurs est autorisé pour les températures ambiantes comprises entre -20 °C et +40 °C.

Pour les températures ambiantes comprises entre -20 °C et -10 °C le démarrage du réducteur pourra se faire uniquement après avoir effectué un préchauffage progressif et homogène du groupe ou avec un fonctionnement « à vide », sans charge raccordée.

La charge pourra ensuite être appliquée à l'arbre du réducteur lorsque la température de celui-ci aura atteint la température de -10 °C ou supérieure.

Todos los reductores de producción de la empresa VARMEC llevan lubricación con aceite sintético.

- *Los reductores del tamaño RFV 25.. al RFV 40.. se suministran lubricados de fábrica. Estos reductores no necesitan la sustitución periódica del lubricante durante toda su vida útil.*
- *Los reductores de la serie RFV 502-503 normalmente se suministran sin lubricante, si no se especifica en el pedido, el cliente debe introducir la cantidad adecuada de aceite antes de la puesta en servicio.*

Para ello los reductores están equipados con tapones de carga, descarga y de nivel para los reductores que se suministran con lubricante, se aconseja que después de la instalación se cambie el tapón cerrado, usado para el transporte, con el tapón de purga que se suministra.

Para orientar correctamente los tapones, para lubricar adecuadamente, recomendamos indicar siempre la posición en la que desea montarlos. En las posiciones de montaje que prevén los reductores con un eje vertical (H5, H6), después de que el aceite sea sacudido mientras funciona, esto no es suficiente para asegurar la lubricación correcta de los cojinetes superiores, se montan cojinetes con lubricación automática tipo 2RS.

Para el llenado correcto del reductor se deberá tomar como referencia absoluta el nivel a mitad del tapón.

Respecto a esta condición, la cantidad de lubricante indicada en la tabla 5 puede sufrir variaciones.

El funcionamiento de los reductores se admite para temperaturas ambiente entre los -20°C y los +40°C.

Para temperaturas ambiente entre los -20°C y los -10°C el reductor se deberá poner en marcha solo después de haber precalentado progresivamente y de forma homogénea el grupo, o bien con funcionamiento "en vacío", sin carga conectada.

La carga se podrá aplicar después al eje del reductor cuando la temperatura de este habrá alcanzado los -10°C, o una temperatura superior.

Todos os redutores produzidos pela VARMEC possuem lubrificação com óleo sintético.

- Os redutores do tamanho RFV 25.. até RFV 40.. são fornecidos com lubrificante de fábrica. Esses redutores não requerem substituições periódicas do lubrificante ao longo de toda a sua vida útil.
- Os redutores da série RFV 502-503 são normalmente fornecidos sem lubrificante, se não houver nenhuma especificação no pedido, e caberá ao cliente introduzir, antes da sua ativação, a quantidade correta de óleo lubrificante.

Para isso os redutores possuem tampões de carga, descarga e nível de óleo; para os redutores fornecidos completos com lubrificante recomenda-se, após fazer a instalação, substituir o tampão fechado usado para o transporte, pelo tampão de alívio fornecido com o equipamento.

A fim de preparar a orientação correta dos tampões, para uma lubrificação adequada aconselhamos indicar sempre a posição de montagem desejada. Nas posições de montagem que requerem redutores com um eixo vertical (H5, H6), onde a batida do óleo durante o funcionamento não seria suficiente para garantir a lubrificação correta dos rolamentos superiores, são montados rolamentos autolubrificantes do tipo 2RS.

Para o correto enchimento do reductor, será necessário, referir-se à linha mediana do tampão de nível.

Com relação a essa condição, a quantidade de lubrificante mostrada na tabela 5 pode apresentar desvios.

O funcionamento dos redutores é admissível em temperaturas ambientais compreendidas entre -20°C e +40°C.

Para temperaturas ambientais compreendidas entre -20°C e -10°C a ativação do reductor só poderá ocorrer após efetuar um pré-aquecimento progressivo e homogêneo do grupo ou com funcionamento "em vazio", sem carga conectada.

A carga poderá então ser aplicada ao eixo do reductor quando a temperatura do reductor for de -10 °C ou superior.



Lubrificazione / Lubrication / Schmierung

Lubrification / Lubricación / Lubrificação

15

Tab.4

Produttore Manufacturer Hersteller Producteur Productor	Lubrificanti consigliati / Recommended lubricants / Empfohlene Schmieröle Lubrifiants recommandés / Lubricantes aconsejados / Lubrificantes aconselhados								
	Oli Minerali Mineral oils Mineralöle Huiles Mineraux Aceites minerales Óleos minerais			Oli Sintetici Polialfaolefine (PAO) Poly-Alpha-Olefin synthetic oils (PAO) Synthetische Poly-Alpha-Olefin-Öle (PAO) Huiles Synthétiques Polyalphaoléfine (PAO) Aceites sintéticos (PAO) Óleos sintéticos (PAO)			Oli Sintetici Poliglicoli (PG) Polyglycol synthetic oils (PG) Synthetische Polyglykolöle (PG) Huiles Synthétiques Polyglycols (PG) Aceites sintéticos (PG) Óleos sintéticos à base de poliglicóis		
	ISO VG 150	ISO VG 220	ISO VG 320	ISO VG 150	ISO VG 220	ISO VG 320	ISO VG 150	ISO VG 220	ISO VG 320
AGIP	Blasia 150	Blasia 220	Blasia 320	-	Blasia SX 220	Blasia SX 320	Blasia S 150	Blasia S 220	Blasia S 320
BP	Energol GR-XP 150	Energol GR-XP 220	Energol GR-XP 320	Energol EPX 150	Energol EPX 220	Energol EPX 320	Energol SG 150	Energol SG-XP 220	Energol SG-XP 320
CASTROL	Alpha SP 150	Alpha SP 220	Alpha SP 320	Alphasyn EP 150	Alphasyn EP 220	Alphasyn EP 320	Alphasyn PG 150	Alphasyn PG 220	Alphasyn PG 320
CHEVRON	Ultra Gear 150	Ultra Gear 220	Ultra Gear 320	Tegra Synthetic Gear 150	Tegra Synthetic Gear 220	Tegra Synthetic Gear 320	HiPerSYN 150	HiPerSYN 220	HiPerSYN 320
ESSO	Spartan EP 150	Spartan EP 220	Spartan EP 320	Spartan S EP 150	Spartan S EP 220	Spartan S EP 320	Glycolube 150	Glycolube 220	Glycolube 320
KLÜBER	Klüberoil GEM 1-150	Klüberoil GEM 1-220	Klüberoil GEM 1-320	Klübersynth EG 4-150	Klübersynth EG 4-220	Klübersynth EG 4-320	Klübersynth GH 6-150	Klübersynth GH 6-220	Klübersynth GH 6-320
MOBIL	Mobilgear XMP 150	Mobilgear XMP 220	Mobilgear XMP 320	Mobilgear SHC XMP 150	Mobilgear SHC XMP 220	Mobilgear SHC XMP 320	Glygoyle 22	Glygoyle 30	Glygoyle HE320
OPTIMOL	Optigear BM 150	Optigear BM 220	Optigear BM 320	Optigear Synthetic A 150	Optigear Synthetic A 220	Optigear Synthetic A 320	Optiflex A 150	Optiflex A 220	Optiflex A 320
SHELL	Omala S2 G 150	Omala S2 G 220	Omala S2 G 320	Omala S4 GX 150	Omala S4 GX 220	Omala S4 GX 320	Omala S4 WE 150	Omala S4 WE 220	Omala S4 WE 320
TEXACO	Meropa 150	Meropa 220	Meropa 320	Pinnacle EP 150	Pinnacle EP 220	Pinnacle EP 320	-	Synlube CLP 220	Synlube CLP 320
TOTAL	Carter EP 150	Carter EP 220	Carter EP 320	Carter SH 150	Carter SH 220	Carter SH 320	Carter SY 150	Carter SY 220	Carter SY 320
TRIBOL	1100/150	1100/220	1100/320	1510/150	1510/220	1510/320	800\150	800\220	800\320

16

Quantità di lubrificante / Quantity of lubricant / Schmiermittelmenge

Quantité de lubrifiant / Cantidad de lubricante / Quantidade de lubrificante

Tab.5

RFV	Lubrificazione permanente / Permanent lubrication / Dauerhafte Schmierung / Lubrification permanente / Lubricación permanente / Lubrificação permanente					
	H1	H2	H3	H4	H5	H6
252	1.20	1.10	0.70	0.70	1.20	0.90
253	1.25	1.10	0.70	0.70	1.30	0.90
302	1.60	1.40	0.80	0.80	1.50	1.30
303	1.70	1.40	0.80	0.80	1.60	1.30
352	2.70	2.60	1.60	1.60	2.90	2.60
353	3.00	2.60	1.60	1.60	3.10	2.60
402	4.80	3.60	2.80	2.80	4.70	4.40
403	5.10	3.60	2.80	2.80	4.70	4.40
502	6.70	6.00	4.40	4.40	7.70	6.40
503	7.5	6.00	4.40	4.40	7.70	6.40

Lubrificazione permanente / Permanent lubrication / Dauerhafte Schmierung / Lubrification permanente / Lubricación permanente / Lubrificação permanente

Q.tà olio espresse in litri / Amount of oil expressed in liters / Ölmenge in Litern

Quantité d'huile exprimée en litres / Cantidad de aceite expresada en litros / Quantidade de óleo expresso em litros



Posizioni di montaggio / Assembly positions / Montagepositionen Positions de montage / Posiciones de montaje / Posições de montagem

17

Le tavole che seguono sono da riferimento nell'interpretazione delle posizioni di montaggio, della collocazione dei tappi e delle quantità di lubrificante.

The tables below should be used as a reference for the interpretation of the assembly positions, the position of the plugs and the quantities of lubricant.

Die nachstehenden Tabellen dienen als Anhaltspunkt für die Auslegung der Montagepositionen, der Position der Verschlüsse und der Schmierstoffmengen.

Les tableaux suivants servent de référence à l'interprétation des positions de montage, de l'emplacement des bouchons et des quantités de lubrifiant.

Las tablas siguientes sirven de referencia para interpretar las posiciones de montaje, la colocación de los tapones y la cantidad de lubricante.

As tabelas seguintes devem ser tomadas como referência na interpretação das posições de montagem, da colocação dos tampões e das quantidades de lubrificante.

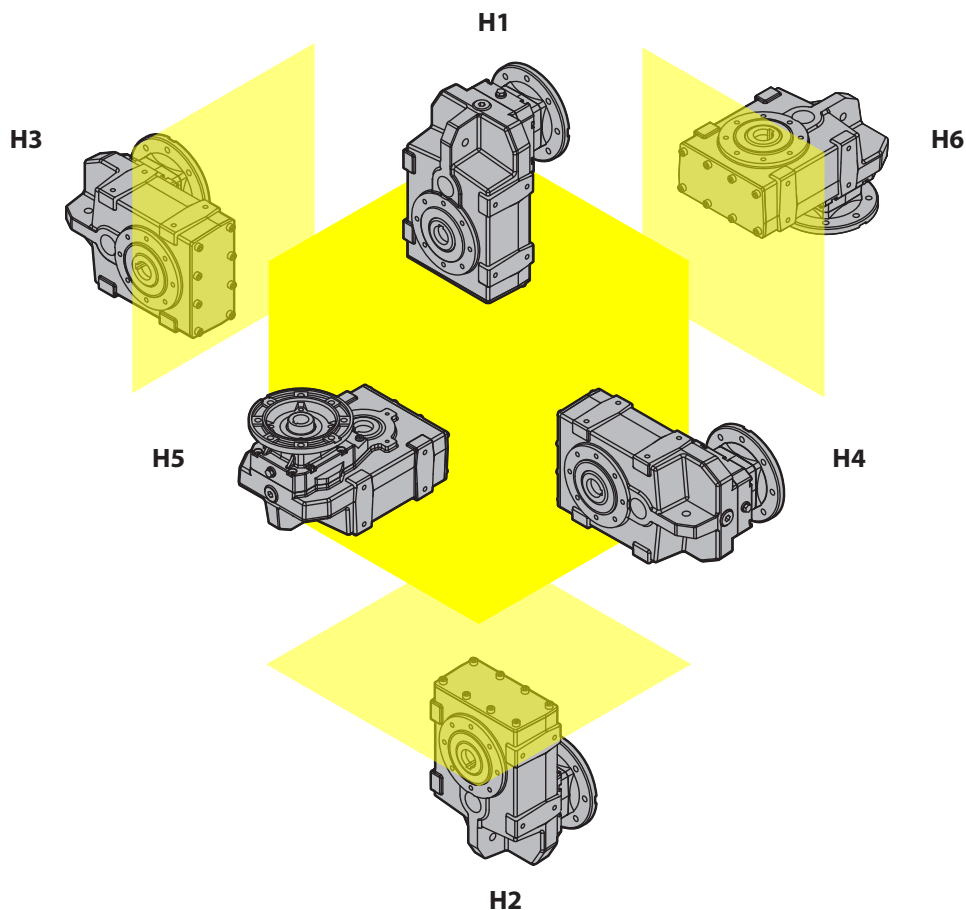



Posizioni di montaggio / Assembly positions / Einbaulage

Positions de montage / Posiciones de montaje / Posições de montagem

17

Orientamento morsettiera / Orientation of terminal box / Einbau der Wartungsanschlüsse

Orientation barrette de connection / Orientación de la caja de bornes / Orientação de caixas de bornes

RFV 25... - RFV 30... - RFV 35...

H1	... IEC / NEMA	...FV	
			<p>A = Standard</p>
H2	... IEC / NEMA	...FV	
			<p>A = Standard</p>
H3	... IEC / NEMA	...FV	
			<p>A = Standard</p>

▽ Tappo di sfato / Breather plug / Entlüftungsschraube / Bouchon d'évent / Tapón respiradero / Tampão de alívio



RFV 25... - RFV 30... - RFV 35...

H4 ... IEC / NEMA ...FV

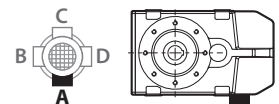
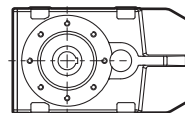
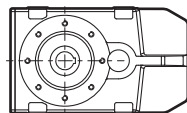
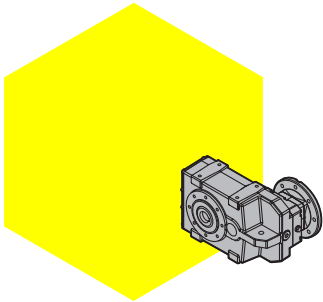

A = Standard

H5 ... IEC / NEMA ...FV

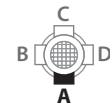
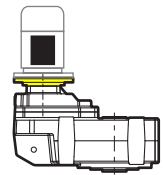
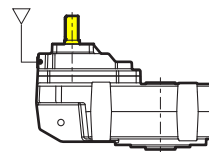
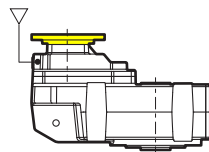
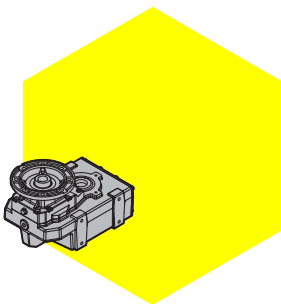

A = Standard

H6 ... IEC / NEMA ...FV

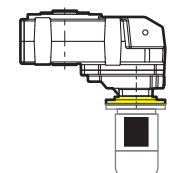
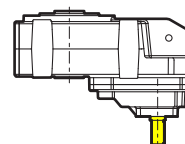
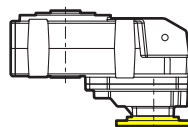
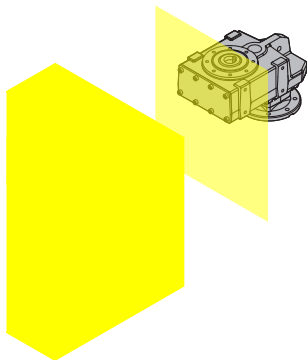

A = Standard

▽ Tappo di sfato / Breather plug / Entlüftungsschraube / Bouchon d'évent / Tapón respiradero / Tampão de alívio



Posizioni di montaggio / *Assembly positions* / Einbaulage

Positions de montage / *Posiciones de montaje* / Posições de montagem

17

Orientamento morsettiera / *Orientation of terminal box* / Einbau der Wartungsanschlüsse

Orientation barrette de connection / *Orientación de la caja de bornes* / Orientação de caixas de bornes

RFV 40... - RFV 50...

H1	... IEC / NEMA	...FV	
			<p>A = Standard</p>
H2	... IEC / NEMA	...FV	
			<p>A = Standard</p>
H3	... IEC / NEMA	...FV	
			<p>A = Standard</p>

(2): 2 stadi di riduzione / *2 stages of reductions* / 2 anzahl der untersetzungen / *2 stades de reduction* / 2 estados de reduccion / *2 parte de reducao*
 (3): 3 stadi di riduzione / *3 stages of reductions* / 3 anzahl der untersetzungen / *3 stades de reduction* / 3 estados de reduccion / *3 parte de reducao*

- ▽ Tappo di sfiato / *Breather plug* / Entlüftungsschraube / *Bouchon d'évent* / *Tapón respiradero* / Tampão de alívio
- Carico olio / *Filler cap* / Ölbefüllung / *Remplissage de l'huile* / *Carga aceite* / *Carga de óleo*
- Livello olio / *Oil level plug* / Ölstand / *Niveau d'huile* / *Nivel aceite* / *Nível de óleo*
- Scarico olio / *Drain plug* / Ölablass / *Vidage de l'huile* / *Descarga de aceite* / *Descarga de óleo*



RFV 40... - RFV 50...

H4	... IEC / NEMA	...FV
H5	... IEC / NEMA	...FV
H6	... IEC / NEMA	...FV

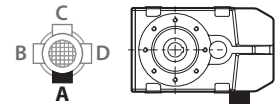

A = Standard

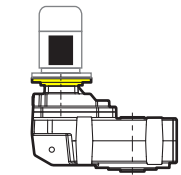

A = Standard



A = Standard

- ▽ Tappo di sfianto / *Breather plug* / Entlüftungsschraube / Bouchon d'évent / *Tapón respiradero* / Tampão de alívio
- Carico olio / *Filler cap* / Ölbefüllung / Remplissage de l'huile / *Carga aceite* / Carga de óleo
- Livello olio / *Oil level plug* / Ölstand / Niveau d'huile / *Nivel aceite* / Nivel de óleo
- Scarico olio / *Drain plug* / Ölablass / Vidage de l'huile / *Descarga de aceite* / Descarga de óleo



Carichi radiali ed assiali / Radial and axial loads / Radial und Axiallasten

18

Gli alberi di entrata e uscita dei riduttori possono essere soggetti a carichi radiali, la cui entità può essere calcolata, in base al tipo di trasmissione realizzata, con la seguente formula:

Input and output shafts of gear reducers can be subject to radial loads, the value of which can be calculated – based on the type of transmission carried out – using the following formula:

$$F_{rc} = \frac{2000 \cdot M_{1,2} \cdot C}{D}$$

F_{rc}	Carico radiale di calcolo sull'albero lento o veloce
$M_{1,2}$	Momento torcente sull'albero lento o veloce
D	Diametro primitivo della ruota per catena, ingranaggio, puleggia, ecc.
$C = 1$	per trasmissioni a catena
$C = 1.25$	per trasmissioni a ingranaggi
$C = 1.5$	per trasmissioni a cinghie dentate
$C = 2.5$	per trasmissioni a cinghie trapezoidali
$C = 3.5$	per trasmissioni a ruote di frizione

F_{rc}	<i>Calculated radial load on input or output shafts</i>
$M_{1,2}$	<i>Transmitted torque at input or output shafts</i>
D	<i>Diameter of chain wheel, gear pulley etc.</i>
$C = 1$	<i>for chain transmission</i>
$C = 1.25$	<i>for gear transmission</i>
$C = 1.5$	<i>for timing belt transmission</i>
$C = 2.5$	<i>for V-belt transmission</i>
$C = 3.5$	<i>for clutch wheel transmission</i>

An Eintriebs- bzw. Abtriebswellen können sowohl Radial- als auch Axiallasten auftreten. Diese Belastungen können mit der folgenden Formel berechnet werden:

F_{rc}	Berechnete Radiallast an Eintriebs- bzw. Abtriebswelle
$M_{1,2}$	Übertragenes Drehmoment an Eintriebs- bzw. Abtriebswelle
D	Durchmesser von Kettenrad, Zahnrad, Riemenscheibe
$C = 1$	für Kettenrad
$C = 1.25$	für Zahnrad
$C = 1.5$	für Zahnriemen
$C = 2.5$	für Keilriemen
$C = 3.5$	für Kupplungsrad

I valori riportati nella tab. 5 (pag. 32), rappresentano i carichi radiali massimi $Fr_{1,2}$ sopportabili dal riduttore, pertanto dovrà essere rispettata la seguente condizione:

The values given in table 5 (page 32) represent the maximum radial loads that the reducer can withstand and therefore the following condition must always apply:

$$F_{rc} \leq Fr_{1,2}$$

Die Werte in den Tabellen 5 (Seite 32) sind die max. zulässigen Radiallasten $Fr_{1,2}$ der Getriebe. Dazu müssen die folgenden Bedingungen gegeben sein:

- I carichi indicati sono riferiti alla mezzeria della sporgenza dell'albero lento e veloce standard del riduttore (pag. 38) e valgono per qualunque direzione di applicazione e senso di rotazione.
- I carichi che si riferiscono a giri che non compaiono nelle tab. 5 si possono ottenere per interpolazione, senza superare i valori relativi i giri minimi che sono i massimi consentiti.
- Contemporaneamente al carico radiale Fr può agire un carico assiale Fa pari a:

- *The given loads refer to the centre of the input and output standard shaft (page 38) and are valid for any applicational direction and sense of rotation.*
- *Any loads relating to speeds that are not given in table 5 can be obtained by interpolation without exceeding the values relative to the minimum rpm which are the maximum allowed.*
- *An axial load Fa can act simultaneously with a radial load equal to:*

$$Fa_1 = 0.2 \cdot Fr_1$$

$$Fa_2 = 0.2 \cdot Fr_2$$

- Der Wert der Radiallasten in der Tabelle ist der Nominalwert, dessen Angriffspunkt in der Mitte der Standard Welle angesetzt (Seite 38) ist und für jede Umdrehungsrichtung gilt.
- Belastungen für Drehzahlen, die nicht in den Tabellen 5 aufgeführt sind, müssen interpoliert werden, ohne die Werte in Bezug auf die minimal zulässigen Runden zu überschreiten.
- Der Wert für die max. Axiallasten ist 1/5 der zulässigen Radiallasten aus der Tabelle, d.h.:

- Nel caso in cui il valore del carico radiale sia nullo, si può considerare il carico assiale ammissibile pari al 50% del valore del carico radiale massimo sull'albero.
- Se il carico è applicato a una distanza x dalla battuta dell'albero lento o veloce (pag. 30), è necessario convertire il nuovo valore di carico radiale ammissibile Fr_x con la seguente relazione:

- *If the value of the radial load happens to be zero, the permitted axial load can be regarded as being 50% of the max radial load on the shaft.*
- *If the load is applied at x distance from the middle of the input or output shaft (page 30) it becomes necessary to convert the new max radial load value Fr_x using the following equation:*

$$Fr_{x,1,2} = Fr_{1,2} \cdot \frac{a}{b+x}$$

valida per

$$x > \frac{U}{2}$$

Valid for

$$x > \frac{U}{2}$$

Gültig für

$$x > \frac{U}{2}$$



Charges radiales et axiales / Cargas radiales y axiales / Cargas radiais e axiais

Les arbres d'entrée et de sortie des réducteurs subissent des charges radiales. Ces charges peuvent être calculées avec la formule suivante:

Los ejes de entrada y salida de los reductores pueden estar expuestos a cargas radiales, las cuales se pueden calcular en base al tipo de la transmisión realizada mediante la siguiente formula:

Eixo de entrada e saída do ridutor pode ser sujeito a cargue radial, a identificação pode ser calculada, em base a tipo de transmissão realizada com a seguinte formula:

$$Frc = \frac{2000 \cdot M_{1,2} \cdot C}{D}$$

Frc Charge radiale calculée sur l'arbre d'entrée ou de sortie

M_{1,2} Couple transmis sur l'arbre d'entrée ou de sortie

D Diamètre de l'élément transmetteur (poulie, roue, pignon,...)

Frc Carga radial de calculo sobre el eje de salida o de entrada

M_{1,2} Momento torsor sobre el eje de salida o entrada

D Diámetro primitivo del piñón, engranaje, polea, etc

Frc Carga radial de cálculo sobre eixo lento ou veloz

M_{1,2} Momento de torção sobre eixo lento ou veloz

D Diametro primitivo da roda para correntes, engranagem, pólia, etc

C = 1 pour transmission par chaine

C = 1.25 pour transmission par engrenage

C = 1.5 pour transmission par courroie dentée

C = 2.5 pour transmission par courroie trapézoïdale

C = 3.5 pour transmission par embrayage

C = 1 Para transmisiones a cadena

C = 1.25 Para transmisiones a engranajes

C = 1.5 Para transmisiones a correa dentada

C = 2.5 Para transmisiones a correa trapezoidal

C = 3.5 Para transmisiones a discos de fricción

C = 1 Para transmissões com correntes

C = 1.25 Para transmissões a engrenagem

C = 1.5 Para transmissões com correntes dentadas

C = 2.5 Para transmissões com correias trapezoidais

C = 3.5 Para transmissões a roda de frizão

Les valeurs mentionnées dans le tableau 5 (page 32), représentent les charges radiales maximales Fr_{1,2}, pour le réducteur, donc la condition suivante devra être respectée:

Los valores indicados en la tab. 5 (pag. 30) representan las cargas radiales máximas permitidas Fr_{1,2}, admitidas por el reductor, por lo tanto deberá respetarse la siguiente condición:

O valor escrito na tab. 5 (pag. 30) representando a carga radial máxima Fr_{1,2} do ridutor. Por tanto deve ser respeitada a seguinte condições:

$$Frc \leq Fr_{1,2}$$

- Les charges indiquée se réfèrent à la ligne mediane de la saillie de l'arbre de sortie et d'entrée du réducteur standard (page 38), et sont valables pour toutes les directions d'application et sens de rotation.
- Les charges à des vitesses qui n'apparaissent pas dans les tableaux, peuvent être obtenues par interpolation, sans dépasser les valeurs relatives aux tours minimums qui sont le maximum autorisé.
- Simultanément à la charge radiale Fr, une charge axiale Fa peut agir:

- Los valores de las cargas radiales mostradas en las tablas son válidas para cargas aplicadas a la mitad del eje standard de salida y de entrada del reductor y son validas para cualquier posición de montaje y sentido de rotación (pag. 38).
- Las cargas que no aparecen en la tab.5 se pueden obtener por interpolación sin exceder los valores relativos a las vueltas mínimas que son las máximas permitidas.
- Simultáneamente a la carga radial Fr puede actuar una carga axial Fa igual a:

- A cargue indicada são referida a metade do comprimento do eixo lento e veloz do standard ridutor (pag. 38) e vale para cada direção de aplicação e senso de rotação.
- A cargue que se refiro a dizer -lo que não aparece na tab. 5 se pode ter para interpolação, sem exceder os valores relativos às voltas mínimas que são as máximas permitidas.
- Contemporaneamente a carga radial Fr, pode agir uma carga empuxo Fa para a:

$$Fa_1 = 0.2 \cdot Fr_1$$

$$Fa_2 = 0.2 \cdot Fr_2$$

- Au cas où la valeur de la charge radiale est nulle, on peut considérer la charge axiale admissible égale au 50% de la valeur de la charge radiale maximale sur l'arbre.
- Si la charge est appliquée à une distance X du battement de l'arbre de sortie ou d'entrée (page 30), il faut transformer la nouvelle valeur de charge radiale admissible Fr_x avec la relation suivante:

- En el caso que el cual el valor de la carga radial sea nulo, se puede considerar la carga axial admisible igual al 50% del valor de la carga radial máxima sobre el eje.
- Si la carga se aplica a una distancia X del rebaje del eje lento (salida) o rápido (entrada, pag.30) es necesario convertir el nuevo valor de carga radial admisible Fr_x con la siguiente formula:

- No caso do valor da carga radial seja nulo, se pode considerar a carga empuxo amissível para 50% do valor da carga radial máxima sobre eixo.
- Se a carga è aplicado uma distância y da extremidade do eixo lento ou veloz (pag. 30) é necessario converter o novo valor de carga radial amissível Fr_x com a seguinte relação:

$$Fr_{x,1,2} = Fr_{1,2} \cdot \frac{a}{b+x}$$

valable pour

Vale para

Valida para

$$x > \frac{U}{2}$$

$$x > \frac{U}{2}$$

$$x > \frac{U}{2}$$



Carichi radiali ed assiali / Radial and axial loads / Radial und Axiallasten

18

Fr_{1-2} = Carico radiale ammissibile sulla mezzeria dell'albero veloce o lento

Fr_{1-2} = Maximum allowable radial load at centre of input / output shaft

Fr_{1-2} = Max. zulässige Radiallast in Wellenmitte

a = Costante del riduttore

a = Constant of the gearbox

a = Getriebekonstante

b = Costante del riduttore

b = Constant of the gearbox

b = Getriebekonstante

x = Distanza del carico dalla battuta dell'albero lento o veloce (mm)

x = Distance of the load from the shoulder of the shaft

x = Abstand des Angriffspunktes ab Wellenschulter

Anche in questo caso, la condizione da verificare sarà la seguente:

In this case also please check that the following applies:

Auch hier muß folgende Bedingung gegeben sein:

$$Frc \leq Frx_{1-2}$$

• Se i valori di carico radiale e assiale ammissibili risultassero inferiore a quelli desiderati, vi preghiamo di consultare il nostro servizio tecnico.

• If the values of admissible radial and axial loads are lower than desired, please consult our technical service department.

• Sollte dies nicht der Fall sein, dann nehmen Sie bitte Rücksprache mit unserem technischen Büro.

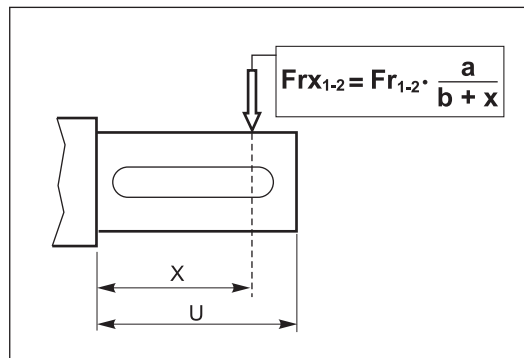
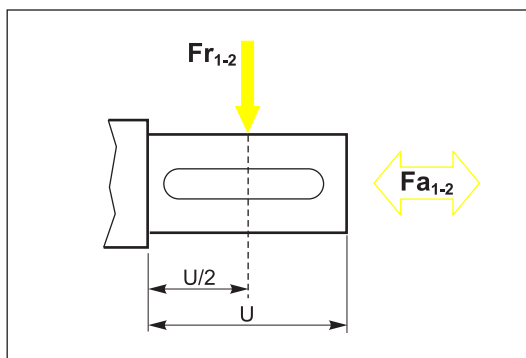



Fr_{1-2} = Charge radiale admissible au milieu de l'arbre d'entrée ou sortie

a = Constante du réducteur

b = Constante du réducteur

x = Distance de la charge du battement de l'arbre de sortie ou d'entrée (mm)

Fr_{1-2} = Carga radial admisible en la mitad del eje rápido (entrada) o lento (salida)

a = Constante del reductor

b = Constante del reductor

x = Distancia de la carga del rebaje del eje lento (salida) o rápido (entrada)

Fr_{1-2} = Radial amissível sobre a metade do comprimento útil do eixo veloz ou lento

a = Constante do ridutor

b = Constante do ridutor

x = Distância da carga da extremidade do eixo lento ou veloz (mm)

Dans ces cas-là aussi, vérifier la condition suivante:

Aunque en este caso la condición de verificar será la siguiente:

Também neste caso, a condição de verificar será a seguinte:

$$Frc \leq Frx_{1-2}$$

• Si les valeurs de charge radiales et axiales applicables sont inférieures à celle désirées, veuillez nous consulter.

• Si los valores de la carga radial y axial admisibles resultan inferiores a los deseados consultar nuestro servicio técnico.

• Se o valor de carga radial e empuxo amissível resultará inferior a quele deseado te pedimo de consulta o nosso serviço técnico.

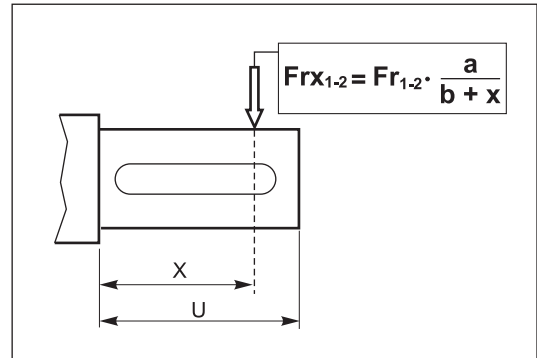
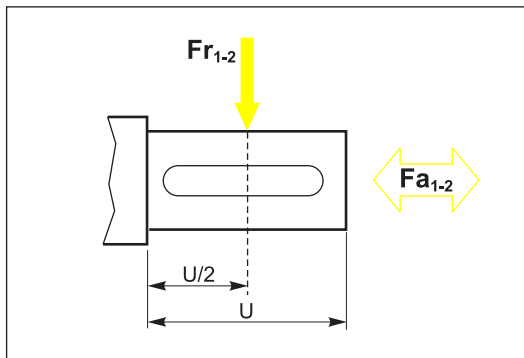



Carichi radiali ed assiali / Radial and axial loads / Radial und Axiallasten

Charges radiales et axiales / Cargas radiales y axiales / Cargue radial e empuxo

18

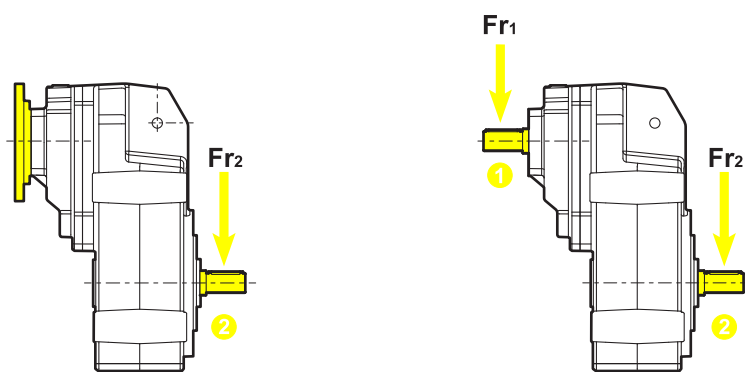





Tab.5



n_1 [min ⁻¹]	Fr_1 [N]									
	FRV...FV									
	252	253	302	303	352	353	402	403	502	503
2800	300	200	300	200	400	300	700	300	1350	400
1400	500	300	500	300	600	500	1050	500	2000	600
900	580	350	580	350	700	580	1220	580	2320	700
700	630	380	630	380	760	630	1320	630	2520	760
500	700	430	700	430	850	700	1480	700	2830	850
300	830	500	830	500	1000	830	1750	830	3350	1000
a	75.8	61.3	75.8	61.3	99	75.8	119.6	75.8	161	99
b	55.8	41.3	55.8	41.3	74	55.8	89.6	55.8	121	74

n_2 [min ⁻¹]	Fr_2 [N]				
	FRV...FV				
	252 - 253	302 - 303	352 - 353	402 - 403	502 - 503
400	1400	1500	2800	3500	4000
300	1500	1600	3000	3700	4500
250	1600	1700	3300	4000	4600
200	1700	1800	3500	4300	5000
150	1750	1900	3800	4600	5500
100	2000	2200	4000	5000	6500
80	2100	2350	4400	5200	7000
60	2350	2600	5100	6000	8000
40	2750	3100	6200	7200	9000
20	2800	4000	6500	8500	12000
a	125	145	169	191.5	231
b	102.5	115	139	151.5	181



$P_1 = 0.09 \text{ kW}$ 63A6 $n_1 = 900 \text{ min}^{-1}$					
n_2 min^{-1}	Mn_2 Nm	f_s		i	
1.8	444	0.8	RFV 303	500.02	63A6
2.0	393	1.5	RFV 353	442.65	63A6
2.1	382	3.1	RFV 403	430.24	63A6
2.1	382	0.9	RFV 303	430.23	63A6
2.4	334	1.0	RFV 303	375.94	63A6
2.5	325	1.8	RFV 353	365.74	63A6
2.5	319	3.8	RFV 403	359.44	63A6
2.7	295	1.2	RFV 303	332.51	63A6
2.9	280	1.3	RFV 303	315.43	63A6
2.9	272	4.4	RFV 403	306.34	63A6
2.9	272	2.2	RFV 353	306.32	63A6
3.1	255	0.8	RFV 253	286.71	63A6
3.3	245	1.4	RFV 303	275.63	63A6
3.3	240	0.8	RFV 253	270.43	63A6
3.4	235	5.1	RFV 403	265.04	63A6
3.6	225	2.7	RFV 353	253.10	63A6
3.6	223	0.9	RFV 253	250.99	63A6
3.7	217	1.6	RFV 303	243.79	63A6
3.9	207	1.0	RFV 253	233.10	63A6
4.2	190	3.2	RFV 353	214.07	63A6
4.4	181	1.1	RFV 253	204.06	63A6
4.7	171	2.0	RFV 303	192.50	63A6
4.9	164	3.7	RFV 353	184.22	63A6
5.3	152	1.3	RFV 253	170.87	63A6
5.4	147	2.4	RFV 303	165.63	63A6
5.7	141	4.3	RFV 353	158.39	63A6
5.8	138	1.4	RFV 253	155.85	63A6
6.1	131	4.6	RFV 353	147.71	63A6
6.2	129	2.7	RFV 303	144.73	63A6
6.7	119	1.7	RFV 253	134.34	63A6
6.9	116	5.2	RFV 353	130.87	63A6
7.0	114	3.1	RFV 303	128.01	63A6
7.4	108	5.5	RFV 353	122.04	63A6
7.5	106	3.3	RFV 303	119.64	63A6
7.7	104	1.9	RFV 253	117.60	63A6
8.1	98	6.1	RFV 353	110.69	63A6
8.7	91	3.8	RFV 303	102.94	63A6
8.7	91	6.6	RFV 353	102.89	63A6
9.1	87	2.3	RFV 253	98.47	63A6
9.4	85	7.1	RFV 353	95.25	63A6
10	82	2.4	RFV 253	92.72	63A6
10	80	4.4	RFV 303	89.95	63A6
11	76	4.6	RFV 302	83.81	63A6
11	71	2.8	RFV 253	79.92	63A6

$P_1 = 0.09 \text{ kW}$ 63A6 $n_1 = 900 \text{ min}^{-1}$					
n_2 min^{-1}	Mn_2 Nm	f_s		i	
12	71	2.8	RFV 252	78.17	63A6
12	65	5.4	RFV 302	72.11	63A6
13	65	3.1	RFV 252	71.42	63A6
14	57	6.1	RFV 302	63.01	63A6
15	56	3.6	RFV 252	61.56	63A6
16	52	6.7	RFV 302	57.66	63A6
17	49	4.1	RFV 252	53.89	63A6
18	45	4.5	RFV 252	49.39	63A6
20	41	4.9	RFV 252	45.12	63A6
22	37	5.2	RFV 252	40.56	63A6
26	32	5.8	RFV 252	34.96	63A6
29	28	6.3	RFV 252	30.61	63A6
35	23	7.2	RFV 252	25.63	63A6
39	21	7.5	RFV 252	23.04	63A6
45	18	8.3	RFV 252	20.17	63A6
47	17	8.4	RFV 252	19.25	63A6
53	15	9.2	RFV 252	16.85	63A6
64	13	10.2	RFV 252	14.11	63A6
71	12	25.1	RFV 302	12.73	63A6
73	11	10.6	RFV 252	12.36	63A6
84	10	11.8	RFV 252	10.66	63A6
96	8	12.9	RFV 252	9.33	63A6
111	7	31.3	RFV 302	8.09	63A6
115	7	14.3	RFV 252	7.81	63A6
126	6	30.8	RFV 302	7.16	63A6



$P_1 = 0.12 \text{ kW}$ 63A4 $n_1 = 1400 \text{ min}^{-1}$ 63B6 $n_1 = 900 \text{ min}^{-1}$					
n_2 min^{-1}	Mn_2 Nm	f_s		i	
2.0	524	1.1	RFV 353	442.65	63B6
2.1	509	2.4	RFV 403	430.24	63B6
2.4	445	0.8	RFV 303	375.94	63B6
2.5	433	1.4	RFV 353	365.74	63B6
2.5	426	2.8	RFV 403	359.44	63B6
2.6	417	0.8	RFV 303	547.27	63A4
2.7	394	0.9	RFV 303	332.51	63B6
2.8	381	0.9	RFV 303	500.02	63A4
2.9	374	0.9	RFV 303	315.43	63B6
2.9	363	1.7	RFV 353	306.32	63B6
2.9	363	3.3	RFV 403	306.34	63B6
3.0	358	1.0	RFV 303	470.88	63A4
3.2	337	1.8	RFV 353	442.65	63A4
3.3	328	3.7	RFV 403	430.24	63A4
3.3	328	1.1	RFV 303	430.23	63A4
3.3	326	1.1	RFV 303	275.63	63B6







Dati tecnici motoriduttori / Motor reducer technical data / Technische Daten der getriebemotoren

Caractéristiques techniques moto-reducteurs / Datos técnicos motorreductores / Características técnicas motoridutor



19



$P_1 = 0.12 \text{ kW}$					
63A4 $n_1 = 1400 \text{ min}^{-1}$ 63B6 $n_1 = 900 \text{ min}^{-1}$					
n_2 min^{-1}	Mn_2 Nm	fs		i	
3.4	314	3.8	RFV 403	265.04	63B6
3.6	300	2.0	RFV 353	253.10	63B6
3.7	289	1.2	RFV 303	243.79	63B6
3.7	286	1.2	RFV 303	375.94	63A4
3.8	278	2.2	RFV 353	365.74	63A4
3.9	274	4.4	RFV 403	359.44	63A4
4.2	254	2.4	RFV 353	214.07	63B6
4.2	253	0.8	RFV 253	332.63	63A4
4.2	253	1.4	RFV 303	332.51	63A4
4.4	242	0.8	RFV 253	204.06	63B6
4.4	240	1.5	RFV 303	315.43	63A4
4.6	233	2.6	RFV 353	306.32	63A4
4.7	228	1.5	RFV 303	192.50	63B6
4.9	218	0.9	RFV 253	286.71	63A4
4.9	218	2.8	RFV 353	184.22	63B6
5.1	210	1.7	RFV 303	275.63	63A4
5.2	206	1.0	RFV 253	270.43	63A4
5.3	202	1.0	RFV 253	170.87	63B6
5.4	196	1.8	RFV 303	165.63	63B6
5.5	193	3.1	RFV 353	253.1	63A4
5.6	191	1.0	RFV 253	250.99	63A4
5.7	186	1.9	RFV 303	243.79	63A4
5.7	188	3.2	RFV 353	158.39	63B6
5.8	185	1.1	RFV 253	155.85	63B6
6.0	177	1.1	RFV 253	233.1	63A4
6.1	175	3.4	RFV 353	147.71	63B6
6.2	171	2.0	RFV 303	144.73	63B6
6.5	163	3.7	RFV 353	214.07	63A4
6.7	159	1.3	RFV 253	134.34	63B6
6.9	155	1.3	RFV 253	204.06	63A4
7.0	152	2.3	RFV 303	128.01	63B6
7.3	147	2.4	RFV 303	192.5	63A4
7.5	142	2.5	RFV 303	119.64	63B6
7.6	140	4.3	RFV 353	184.22	63A4
7.7	139	1.4	RFV 253	117.60	63B6
8.2	130	1.5	RFV 253	170.87	63A4
8.5	126	2.8	RFV 303	165.63	63A4
8.7	122	2.9	RFV 303	102.94	63B6
9.0	119	1.7	RFV 253	155.85	63A4
9.1	117	1.7	RFV 253	98.47	63B6
10	110	1.8	RFV 253	92.72	63B6
10	102	2.0	RFV 253	134.34	63A4
10	110	3.2	RFV 303	144.73	63A4
11	101	3.5	RFV 302	83.81	63B6

$P_1 = 0.12 \text{ kW}$					
63A4 $n_1 = 1400 \text{ min}^{-1}$ 63B6 $n_1 = 900 \text{ min}^{-1}$					
n_2 min^{-1}	Mn_2 Nm	fs		i	
11	97	3.6	RFV 303	128.01	63A4
11	95	2.1	RFV 253	79.92	63B6
12	95	2.1	RFV 252	78.17	63B6
12	90	2.2	RFV 253	117.6	63A4
12	91	3.8	RFV 303	119.64	63A4
13	86	2.3	RFV 252	71.42	63B6
14	75	2.7	RFV 253	98.47	63A4
15	74	2.7	RFV 252	61.56	63B6
15	71	2.8	RFV 253	92.72	63A4
16	68	5.1	RFV 303	89.95	63A4
17	65	3.1	RFV 252	53.89	63B6
17	65	5.4	RFV 302	83.81	63A4
18	61	3.3	RFV 253	79.92	63A4
18	61	3.3	RFV 252	78.17	63A4
20	56	3.6	RFV 252	71.42	63A4
22	49	3.9	RFV 252	40.56	63B6
23	48	4.2	RFV 252	61.56	63A4
26	42	4.8	RFV 252	53.89	63A4
28	38	5.2	RFV 252	49.39	63A4
29	37	4.8	RFV 252	30.61	63B6
35	31	5.4	RFV 252	25.63	63B6
53	20	6.9	RFV 252	16.85	63B6
61	18	8.7	RFV 252	23.04	63A4
69	16	9.6	RFV 252	20.17	63A4
73	15	9.8	RFV 252	19.25	63A4
84	13	8.8	RFV 252	10.66	63B6
96	11	9.7	RFV 252	9.33	63B6
99	11	11.9	RFV 252	14.11	63A4
110	10	29.3	RFV 302	12.73	63A4
113	10	12.4	RFV 252	12.36	63A4
126	9	23.1	RFV 302	7.16	63B6
131	8	13.8	RFV 252	10.66	63A4
150	7	15.0	RFV 252	9.33	63A4
179	6	16.6	RFV 252	7.81	63A4
196	6	35.9	RFV 302	7.16	63A4

$P_1 = 0.18 \text{ kW}$					
63A2 $n_1 = 2800 \text{ min}^{-1}$ 63B4 $n_1 = 1400 \text{ min}^{-1}$ 71A6 $n_1 = 900 \text{ min}^{-1}$					
n_2 min^{-1}	Mn_2 Nm	fs		i	
2.0	786	0.8	RFV 353	442.65	71A6
2.1	764	1.6	RFV 403	430.24	71A6
2.5	650	0.9	RFV 353	365.74	71A6
2.5	638	1.9	RFV 403	359.44	71A6
2.6	603	3.6	RFV 503	339.66	71A6
2.9	544	1.1	RFV 353	306.32	71A6



$P_1 = 0.18 \text{ kW}$					
63A2 $n_1 = 2800 \text{ min}^{-1}$ 63B4 $n_1 = 1400 \text{ min}^{-1}$ 71A6 $n_1 = 900 \text{ min}^{-1}$					
n_2 min^{-1}	Mn_2 Nm	fs		i	
2.9	544	2.2	RFV 403	306.34	71A6
3.2	505	1.2	RFV 353	442.65	63B4
3.3	491	2.4	RFV 403	430.24	63B4
3.4	471	2.5	RFV 403	265.04	71A6
3.6	450	1.3	RFV 353	253.10	71A6
3.6	445	2.7	RFV 403	250.36	71A6
3.7	433	0.8	RFV 303	243.79	71A6
3.7	429	0.8	RFV 303	375.94	63B4
3.8	418	1.4	RFV 353	365.74	63B4
3.9	410	2.9	RFV 403	359.44	63B4
4.2	380	0.9	RFV 303	332.51	63B4
4.2	380	1.6	RFV 353	214.07	71A6
4.2	379	3.2	RFV 403	213.38	71A6
4.4	360	1.0	RFV 303	315.43	63B4
4.6	350	1.7	RFV 353	306.32	63B4
4.6	350	3.4	RFV 403	306.34	63B4
4.8	334	3.6	RFV 403	188.04	71A6
4.9	327	1.8	RFV 353	184.22	71A6
5.1	315	1.1	RFV 303	275.63	63B4
5.1	312	1.1	RFV 303	547.27	63A2
5.3	303	4.0	RFV 403	265.04	63B4
5.4	294	1.2	RFV 303	165.63	71A6
5.5	289	2.1	RFV 353	253.10	63B4
5.6	285	1.2	RFV 303	500.02	63A2
5.7	278	1.3	RFV 303	243.79	63B4
5.7	281	2.1	RFV 353	158.39	71A6
5.9	269	1.3	RFV 303	470.88	63A2
6.0	266	0.8	RFV 253	233.10	63B4
6.1	262	2.3	RFV 353	147.71	71A6
6.2	257	1.4	RFV 303	144.73	71A6
6.3	253	2.4	RFV 353	442.65	63A2
6.5	244	2.5	RFV 353	214.07	63B4
6.9	233	0.9	RFV 253	204.06	63B4
6.9	232	2.6	RFV 353	130.87	71A6
7.0	227	1.5	RFV 303	128.01	71A6
7.3	220	1.6	RFV 303	192.50	63B4
7.4	215	1.6	RFV 303	375.94	63A2
7.4	217	2.8	RFV 353	122.04	71A6
7.5	213	1.6	RFV 303	119.64	71A6
7.6	210	2.9	RFV 353	184.22	63B4
7.7	209	1.0	RFV 253	117.60	71A6
7.7	209	2.9	RFV 353	365.74	63A2
8.1	197	3.1	RFV 353	110.69	71A6
8.2	195	1.0	RFV 253	170.87	63B4



$P_1 = 0.18 \text{ kW}$					
63A2 $n_1 = 2800 \text{ min}^{-1}$ 63B4 $n_1 = 1400 \text{ min}^{-1}$ 71A6 $n_1 = 900 \text{ min}^{-1}$					
n_2 min^{-1}	Mn_2 Nm	fs		i	
8.4	190	1.1	RFV 253	332.63	63A2
8.4	190	1.8	RFV 303	332.51	63A2
8.5	189	1.9	RFV 303	165.63	63B4
8.7	183	1.9	RFV 303	102.94	71A6
8.8	181	3.3	RFV 353	158.39	63B4
8.9	180	1.9	RFV 303	315.43	63A2
9.0	178	1.1	RFV 253	155.85	63B4
9.1	175	1.1	RFV 253	98.47	71A6
9.1	175	3.4	RFV 353	306.32	63A2
9.4	169	3.5	RFV 353	95.25	71A6
9.5	169	3.6	RFV 353	147.71	63B4
9.7	165	2.1	RFV 303	144.73	63B4
10	165	1.2	RFV 253	92.72	71A6
10	164	1.2	RFV 253	286.71	63A2
10	153	1.3	RFV 253	134.34	63B4
10	160	2.2	RFV 303	89.95	71A6
11	146	2.4	RFV 303	128.01	63B4
11	139	4.3	RFV 353	122.04	63B4
12	134	1.5	RFV 253	117.60	63B4
12	137	2.6	RFV 303	119.64	63B4
12	131	2.7	RFV 302	72.11	71A6
13	130	1.5	RFV 252	71.42	71A6
13	126	4.7	RFV 353	110.69	63B4
14	112	1.8	RFV 253	98.47	63B4
14	118	3.0	RFV 303	102.94	63B4
15	112	1.8	RFV 252	61.56	71A6
15	106	1.9	RFV 253	92.72	63B4
16	105	3.3	RFV 302	57.66	71A6
16	103	3.4	RFV 303	89.95	63B4
16	98	2.1	RFV 253	170.87	63A2
17	98	2.0	RFV 252	53.89	71A6
17	98	3.6	RFV 302	83.81	63B4
17	95	3.7	RFV 303	165.63	63A2
18	91	2.2	RFV 252	78.17	63B4
18	89	2.2	RFV 253	155.85	63A2
19	84	4.2	RFV 302	72.11	63B4
20	83	2.4	RFV 252	71.42	63B4
20	81	4.3	RFV 302	44.56	71A6
21	78	4.5	RFV 302	67.01	63B4
22	74	2.6	RFV 252	40.56	71A6
22	73	4.8	RFV 302	63.01	63B4
23	72	2.8	RFV 252	61.56	63B4
24	67	3.0	RFV 253	117.60	63A2
26	63	3.2	RFV 252	53.89	63B4







Dati tecnici motoriduttori / Motor reducer technical data / Technische Daten der getriebemotoren

Caractéristiques techniques moto-reducteurs / Datos técnicos motorreductores / Características técnicas motoridutor

19



$P_1 = 0.18 \text{ kW}$					
63A2 $n_1 = 2800 \text{ min}^{-1}$ 63B4 $n_1 = 1400 \text{ min}^{-1}$ 71A6 $n_1 = 900 \text{ min}^{-1}$					
n_2 min^{-1}	Mn_2 Nm	fs		i	
28	58	3.5	RFV 252	49.39	63B4
29	56	3.2	RFV 252	30.61	71A6
30	53	3.8	RFV 253	92.72	63A2
31	53	3.8	RFV 252	45.12	63B4
35	47	4.0	RFV 252	40.56	63B4
36	46	4.4	RFV 252	78.17	63A2
39	42	3.7	RFV 252	23.04	71A6
39	42	4.8	RFV 252	71.42	63A2
40	41	4.5	RFV 252	34.96	63B4
45	37	4.1	RFV 252	20.17	71A6
46	36	4.9	RFV 252	30.61	63B4
47	35	4.2	RFV 252	19.25	71A6
53	31	4.6	RFV 252	16.85	71A6
61	27	5.8	RFV 252	23.04	63B4
64	26	5.1	RFV 252	14.11	71A6
73	22	5.3	RFV 252	12.36	71A6
80	20	8.1	RFV 252	34.96	63A2
83	20	7.1	RFV 252	16.85	63B4
99	16	8.0	RFV 252	14.11	63B4
100	16	42.9	RFV 402	8.96	71A6
110	15	19.5	RFV 302	12.7	63B4
113	14	8.3	RFV 252	12.36	63B4
122	13	9.7	RFV 252	23.04	63A2
131	12	9.2	RFV 252	10.66	63B4
139	12	10.7	RFV 252	20.17	63A2
145	11	10.8	RFV 252	19.25	63A2
150	11	10.0	RFV 252	9.33	63B4
166	10	11.9	RFV 252	16.85	63A2
179	9	11.1	RFV 252	7.81	63B4
196	8	23.9	RFV 302	7.16	63B4
220	7	32.6	RFV 302	12.73	63A2
227	7	13.8	RFV 252	12.36	63A2
263	6	15.3	RFV 252	10.66	63A2
300	5	16.7	RFV 252	9.33	63A2
359	5	18.5	RFV 252	7.81	63A2
391	4	39.9	RFV 302	7.16	63A2



$P_1 = 0.25 \text{ kW}$					
63B2 $n_1 = 2800 \text{ min}^{-1}$ 71A4 $n_1 = 1400 \text{ min}^{-1}$ 71B6 $n_1 = 900 \text{ min}^{-1}$					
n_2 min^{-1}	Mn_2 Nm	fs		i	
2.1	1061	1.1	RFV 403	430.24	71B6
2.5	887	1.4	RFV 403	359.44	71B6
2.6	838	2.6	RFV 503	339.66	71B6
2.9	756	1.6	RFV 403	306.34	71B6
2.9	759	2.9	RFV 503	307.74	71B6
3.3	682	1.8	RFV 403	430.24	71A4

$P_1 = 0.25 \text{ kW}$					
63B2 $n_1 = 2800 \text{ min}^{-1}$ 71A4 $n_1 = 1400 \text{ min}^{-1}$ 71B6 $n_1 = 900 \text{ min}^{-1}$					
n_2 min^{-1}	Mn_2 Nm	fs		i	
3.4	654	1.8	RFV 403	265.04	71B6
3.5	635	3.5	RFV 503	257.57	71B6
3.6	624	1.0	RFV 353	253.10	71B6
3.6	618	1.9	RFV 403	250.36	71B6
3.8	580	1.0	RFV 353	365.74	71A4
3.9	570	2.1	RFV 403	359.44	71A4
4.1	539	4.1	RFV 503	339.66	71A4
4.2	528	1.1	RFV 353	214.07	71B6
4.2	526	2.3	RFV 403	213.38	71B6
4.6	486	1.2	RFV 353	306.32	71A4
4.6	486	2.5	RFV 403	306.34	71A4
4.9	454	1.3	RFV 353	184.22	71B6
5.1	437	0.8	RFV 303	275.63	71A4
5.3	420	2.9	RFV 403	265.04	71A4
5.4	409	0.9	RFV 303	165.63	71B6
5.5	401	1.5	RFV 353	253.10	71A4
5.6	397	3.0	RFV 403	250.36	71A4
5.7	387	0.9	RFV 303	243.79	71A4
5.7	391	1.5	RFV 353	158.39	71B6
6.1	364	1.6	RFV 353	147.71	71B6
6.1	364	3.3	RFV 403	147.71	71B6
6.2	357	1.0	RFV 303	144.73	71B6
6.5	342	3.5	RFV 403	138.65	71B6
6.5	340	1.8	RFV 353	214.07	71A4
6.6	338	3.5	RFV 403	213.38	71A4
6.9	323	1.9	RFV 353	130.87	71B6
6.9	323	3.7	RFV 403	203.77	71A4
7.0	316	1.1	RFV 303	128.01	71B6
7.1	311	3.9	RFV 403	125.89	71B6
7.3	305	1.1	RFV 303	192.50	71A4
7.4	298	4.0	RFV 403	188.04	71A4
7.5	295	1.2	RFV 303	119.64	71B6
7.6	292	2.1	RFV 353	184.22	71A4
7.7	290	2.1	RFV 353	365.74	63B2
8.1	273	2.2	RFV 353	110.69	71B6
8.2	270	4.4	RFV 403	170.24	71A4
8.5	263	1.3	RFV 303	165.63	71A4
8.8	251	2.4	RFV 353	158.39	71A4
9.0	247	0.8	RFV 253	155.85	71A4
9.4	235	2.6	RFV 353	95.25	71B6
9.5	234	2.6	RFV 353	147.71	71A4
9.7	230	1.5	RFV 303	144.73	71A4
10	213	0.9	RFV 253	134.34	71A4
10	222	1.6	RFV 303	89.95	71B6



$P_1 = 0.25 \text{ kW}$					
63B2 $n_1 = 2800 \text{ min}^{-1}$ 71A4 $n_1 = 1400 \text{ min}^{-1}$ 71B6 $n_1 = 900 \text{ min}^{-1}$					
n_2 min^{-1}	Mn_2 Nm	fs		i	
10	219	1.6	RFV 303	275.63	63B2
10	220	5.5	RFV 403	138.65	71A4
11	203	1.7	RFV 303	128.01	71A4
11	208	2.9	RFV 353	130.87	71A4
12	197	1.0	RFV 252	78.17	71B6
12	187	1.1	RFV 253	117.60	71A4
12	190	1.8	RFV 303	119.64	71A4
13	180	1.1	RFV 252	71.42	71B6
13	176	3.4	RFV 353	110.69	71A4
13	173	3.5	RFV 352	68.58	71B6
14	156	1.3	RFV 253	98.47	71A4
14	159	2.2	RFV 302	63.01	71B6
14	163	2.1	RFV 303	102.94	71A4
14	163	3.7	RFV 353	102.89	71A4
15	155	1.3	RFV 252	61.56	71B6
15	147	1.4	RFV 253	92.72	71A4
16	145	2.4	RFV 302	57.66	71B6
16	143	2.5	RFV 303	89.95	71A4
17	136	1.5	RFV 252	53.89	71B6
17	136	2.6	RFV 302	83.81	71A4
18	127	1.6	RFV 252	78.17	71A4
18	127	1.6	RFV 253	79.92	71A4
19	117	3.0	RFV 302	72.11	71A4
20	116	1.7	RFV 252	71.42	71A4
21	109	3.2	RFV 302	67.01	71A4
22	102	1.9	RFV 252	40.56	71B6
22	102	3.4	RFV 302	63.01	71A4
23	100	2.0	RFV 252	61.56	71A4
24	93	3.7	RFV 302	57.66	71A4
26	87	2.3	RFV 252	53.89	71A4
28	80	2.5	RFV 252	49.39	71A4
29	77	2.3	RFV 252	30.61	71B6
31	73	2.7	RFV 252	45.12	71A4
35	66	2.9	RFV 252	40.56	71A4
39	58	2.7	RFV 252	23.04	71B6
40	57	3.2	RFV 252	34.96	71A4
45	51	3.0	RFV 252	20.17	71B6
46	50	3.5	RFV 252	30.61	71A4
47	49	3.0	RFV 252	19.25	71B6
53	42	3.3	RFV 252	16.85	71B6
55	42	4.0	RFV 252	25.63	71A4
61	37	4.2	RFV 252	23.04	71A4
64	36	3.7	RFV 252	14.11	71B6
69	33	4.6	RFV 252	20.17	71A4

$P_1 = 0.25 \text{ kW}$					
63B2 $n_1 = 2800 \text{ min}^{-1}$ 71A4 $n_1 = 1400 \text{ min}^{-1}$ 71B6 $n_1 = 900 \text{ min}^{-1}$					
n_2 min^{-1}	Mn_2 Nm	fs		i	
73	31	4.7	RFV 252	19.25	71A4
80	28	5.9	RFV 252	34.96	63B2
83	27	5.1	RFV 252	16.85	71A4
99	23	5.7	RFV 252	14.11	71A4
109	21	6.7	RFV 252	25.63	63B2
122	19	7.0	RFV 252	23.04	63B2
131	17	6.6	RFV 252	10.66	71A4
139	16	7.7	RFV 252	20.17	63B2
145	16	7.8	RFV 252	19.25	63B2
150	15	7.2	RFV 252	9.33	71A4
166	14	8.5	RFV 252	16.85	63B2
179	13	8.0	RFV 252	7.81	71A4
196	12	17.2	RFV 302	7.16	71A4
198	11	9.6	RFV 252	14.11	63B2
227	10	9.9	RFV 252	12.36	63B2
263	9	11.0	RFV 252	10.66	63B2
300	8	12.0	RFV 252	9.33	63B2
359	6	13.3	RFV 252	7.81	63B2
391	6	28.7	RFV 302	7.16	63B2



$P_1 = 0.37 \text{ kW}$					
71A2 $n_1 = 2800 \text{ min}^{-1}$ 71B4 $n_1 = 1400 \text{ min}^{-1}$ 80A6 $n_1 = 900 \text{ min}^{-1}$					
n_2 min^{-1}	Mn_2 Nm	fs		i	
2.1	1571	0.8	RFV 403	430.24	80A6
2.5	1312	0.9	RFV 403	359.44	80A6
2.6	1240	1.8	RFV 503	339.66	80A6
2.9	1119	1.1	RFV 403	306.34	80A6
2.9	1124	2.0	RFV 503	307.74	80A6
3.3	1010	1.2	RFV 403	430.24	71B4
3.5	940	2.3	RFV 503	257.57	80A6
3.6	914	1.3	RFV 403	250.36	80A6
3.9	844	1.4	RFV 403	359.44	71B4
4.1	797	2.8	RFV 503	339.66	71B4
4.2	782	0.8	RFV 353	214.07	80A6
4.2	779	1.5	RFV 403	213.38	80A6
4.4	744	1.6	RFV 403	203.77	80A6
4.4	743	3.0	RFV 503	203.50	80A6
4.5	722	3.0	RFV 503	307.74	71B4
4.6	719	0.8	RFV 353	306.32	71B4
4.6	719	1.7	RFV 403	306.34	71B4
4.9	673	0.9	RFV 353	184.22	80A6
4.9	673	3.3	RFV 503	184.38	80A6
5.3	622	1.9	RFV 403	265.04	71B4
5.4	605	3.6	RFV 503	257.57	71B4
5.5	594	1.0	RFV 353	253.10	71B4





Dati tecnici motoriduttori / Motor reducer technical data / Technische Daten der getriebemotoren

Caractéristiques techniques moto-réducteurs / Datos técnicos motorreductores / Características técnicas motoridutor

19

$P_1 = 0.37 \text{ kW}$					
71A2 $n_1 = 2800 \text{ min}^{-1}$ 71B4 $n_1 = 1400 \text{ min}^{-1}$ 80A6 $n_1 = 900 \text{ min}^{-1}$					
n_2 min^{-1}	Mn_2 Nm	fs		i	
5.6	588	2.0	RFV 403	250.36	71B4
5.7	578	1.0	RFV 353	158.39	80A6
6.0	547	4.0	RFV 503	232.84	71B4
6.1	539	1.1	RFV 353	147.71	80A6
6.1	539	2.2	RFV 403	147.71	80A6
6.5	502	1.2	RFV 353	214.07	71B4
6.6	501	2.4	RFV 403	213.38	71B4
6.9	478	2.5	RFV 403	203.77	71B4
7.3	452	0.8	RFV 303	192.50	71B4
7.4	441	2.7	RFV 403	188.04	71B4
7.6	432	1.4	RFV 353	184.22	71B4
8.1	404	1.5	RFV 353	110.69	80A6
8.2	400	3.0	RFV 403	170.24	71B4
8.3	398	3.0	RFV 403	108.91	80A6
8.5	389	0.9	RFV 303	165.63	71B4
8.7	376	3.2	RFV 403	160.26	71B4
8.8	372	1.6	RFV 353	158.39	71B4
8.9	370	3.2	RFV 403	101.27	80A6
9.4	348	1.7	RFV 353	95.25	80A6
9.5	347	1.7	RFV 353	147.71	71B4
9.7	340	1.0	RFV 303	144.73	71B4
10	325	3.7	RFV 403	138.65	71B4
10	315	3.8	RFV 403	86.31	80A6
11	313	1.1	RFV 302	83.81	80A6
11	300	1.2	RFV 303	128.01	71B4
11	307	2.0	RFV 353	130.87	71B4
12	281	1.2	RFV 303	119.64	71B4
12	269	1.3	RFV 302	72.11	80A6
13	266	0.8	RFV 252	71.42	80A6
13	250	1.4	RFV 302	67.01	80A6
13	260	2.3	RFV 353	110.69	71B4
13	256	2.3	RFV 352	68.58	80A6
14	231	0.9	RFV 253	98.47	71B4
14	242	1.4	RFV 303	102.94	71B4
14	235	1.5	RFV 302	63.01	80A6
14	242	2.5	RFV 353	102.89	71B4
15	218	0.9	RFV 253	92.72	71B4
15	226	1.5	RFV 303	192.50	71A2
15	224	2.7	RFV 353	95.25	71B4
16	215	1.6	RFV 302	57.66	80A6
16	211	1.7	RFV 303	89.95	71B4
16	211	2.8	RFV 352	56.66	80A6
17	201	1.0	RFV 252	53.89	80A6
17	201	1.7	RFV 302	83.81	71B4



$P_1 = 0.37 \text{ kW}$					
71A2 $n_1 = 2800 \text{ min}^{-1}$ 71B4 $n_1 = 1400 \text{ min}^{-1}$ 80A6 $n_1 = 900 \text{ min}^{-1}$					
n_2 min^{-1}	Mn_2 Nm	fs		i	
18	187	1.1	RFV 252	78.17	71B4
18	188	1.9	RFV 302	50.38	80A6
19	173	2.0	RFV 302	72.11	71B4
20	171	1.2	RFV 252	71.42	71B4
20	166	2.1	RFV 302	44.56	80A6
21	161	2.2	RFV 302	67.01	71B4
22	151	1.3	RFV 252	40.56	80A6
22	151	2.3	RFV 302	63.01	71B4
23	148	1.4	RFV 252	61.56	71B4
24	138	2.5	RFV 302	57.66	71B4
25	136	4.4	RFV 352	56.66	71B4
26	129	1.5	RFV 252	53.89	71B4
26	129	2.7	RFV 302	34.71	80A6
28	118	1.7	RFV 252	49.39	71B4
28	121	2.9	RFV 302	50.38	71B4
29	114	1.5	RFV 252	30.61	80A6
30	113	3.1	RFV 302	30.28	80A6
31	108	1.8	RFV 252	45.12	71B4
34	99	3.5	RFV 302	26.46	80A6
35	97	2.0	RFV 252	40.56	71B4
35	97	3.6	RFV 302	40.34	71B4
38	87	3.9	RFV 302	23.40	80A6
39	86	1.8	RFV 252	23.04	80A6
40	84	2.2	RFV 252	34.96	71B4
40	83	4.2	RFV 302	34.71	71B4
45	75	2.0	RFV 252	20.17	80A6
45	75	4.4	RFV 302	20.14	80A6
46	73	2.4	RFV 252	30.61	71B4
47	72	2.0	RFV 252	19.25	80A6
53	63	2.2	RFV 252	16.85	80A6
55	61	2.7	RFV 252	25.63	71B4
57	59	3.4	RFV 252	49.39	71A2
61	55	2.8	RFV 252	23.04	71B4
64	53	2.5	RFV 252	14.11	80A6
69	48	3.1	RFV 252	20.17	71B4
73	46	3.2	RFV 252	19.25	71B4
83	40	3.5	RFV 252	16.85	71B4
84	40	2.9	RFV 252	10.66	80A6
91	37	4.2	RFV 252	30.61	71A2
96	35	3.1	RFV 252	9.33	80A6
99	34	3.9	RFV 252	14.11	71B4
110	31	9.5	RFV 302	12.73	71B4
113	30	4.0	RFV 252	12.36	71B4
122	28	4.7	RFV 252	23.04	71A2





Dati tecnici motoriduttori / Motor reducer technical data / Technische Daten der getriebemotoren

Caractéristiques techniques moto-reducteurs / Datos técnicos motorreductores / Características técnicas motoridutor

$P_1 = 0.37 \text{ kW}$					
71A2 $n_1 = 2800 \text{ min}^{-1}$ 71B4 $n_1 = 1400 \text{ min}^{-1}$ 80A6 $n_1 = 900 \text{ min}^{-1}$					
n_2 min^{-1}	Mn_2 Nm	fs		i	
131	26	4.5	RFV 252	10.66	71B4
139	24	5.2	RFV 252	20.17	71A2
145	23	5.3	RFV 252	19.25	71A2
150	22	4.9	RFV 252	9.33	71B4
166	20	5.8	RFV 252	16.85	71A2
173	19	11.9	RFV 302	8.09	71B4
179	19	5.4	RFV 252	7.81	71B4
188	18	23.9	RFV 352	14.91	71A2
196	17	11.7	RFV 302	7.16	71B4
198	17	6.5	RFV 252	14.11	71A2
212	16	36.0	RFV 402	6.60	71B4
220	15	15.8	RFV 302	12.73	71A2
227	15	6.7	RFV 252	12.36	71A2
252	13	21.9	RFV 352	5.55	71B4
260	13	17.7	RFV 302	10.76	71A2
261	13	49.6	RFV 402	10.72	71A2
263	13	7.4	RFV 252	10.66	71A2
290	12	39.2	RFV 402	4.83	71B4
300	11	8.1	RFV 252	9.33	71A2
359	9	9.0	RFV 252	7.81	71A2
391	9	19.4	RFV 302	7.16	71A2
424	8	59.9	RFV 402	6.60	71A2
434	8	34.7	RFV 352	6.45	71A2
502	7	63.2	RFV 402	5.58	71A2
505	7	36.6	RFV 352	5.55	71A2
580	6	65.6	RFV 402	4.83	71A2

$P_1 = 0.55 \text{ kW}$					
71B2 $n_1 = 2800 \text{ min}^{-1}$ 80A4 $n_1 = 1400 \text{ min}^{-1}$ 80B6 $n_1 = 900 \text{ min}^{-1}$					
n_2 min^{-1}	Mn_2 Nm	fs		i	
6.0	812	2.7	RFV 503	232.84	80A4
6.1	802	1.5	RFV 403	147.71	80B6
6.4	767	2.9	RFV 503	141.30	80B6
6.5	747	0.8	RFV 353	214.07	80A4
6.6	745	1.6	RFV 403	213.38	80A4
6.7	729	3.0	RFV 503	134.39	80B6
6.9	710	0.8	RFV 353	130.87	80B6
6.9	711	1.7	RFV 403	203.77	80A4
7.1	683	1.8	RFV 403	125.89	80B6
7.2	680	3.2	RFV 503	194.88	80A4
7.4	662	0.9	RFV 353	122.04	80B6
7.4	656	1.8	RFV 403	188.04	80A4
7.6	643	0.9	RFV 353	184.22	80A4
7.6	643	3.4	RFV 503	184.38	80A4
7.9	618	3.6	RFV 503	177.23	80A4
8.1	601	1.0	RFV 353	110.69	80B6
8.2	594	2.0	RFV 403	170.24	80A4
8.3	591	2.0	RFV 403	108.91	80B6
8.7	559	2.1	RFV 403	160.26	80A4
8.8	553	1.1	RFV 353	158.39	80A4
8.9	550	2.2	RFV 403	101.27	80B6
9.4	517	1.2	RFV 353	95.25	80B6
9.5	515	1.2	RFV 353	147.71	80A4
9.5	515	2.3	RFV 403	147.71	80A4
10	484	2.5	RFV 403	138.65	80A4
11	465	0.8	RFV 302	83.81	80B6
11	457	1.3	RFV 353	130.87	80A4
11	439	2.7	RFV 403	125.89	80A4
12	400	0.9	RFV 302	72.11	80B6
12	405	3.0	RFV 403	74.67	80B6
13	372	0.9	RFV 302	67.01	80B6
13	380	1.6	RFV 352	68.58	80B6
13	386	1.6	RFV 353	110.69	80A4
13	380	3.2	RFV 402	68.47	80B6
13	380	3.2	RFV 403	108.91	80A4
14	349	1.0	RFV 302	63.01	80B6
14	359	1.7	RFV 353	102.89	80A4
14	353	3.4	RFV 403	101.27	80A4
15	336	1.0	RFV 303	192.50	71B2
15	332	1.8	RFV 353	95.25	80A4
16	320	1.1	RFV 302	57.66	80B6
16	314	1.9	RFV 352	56.66	80B6
16	297	2.0	RFV 353	85.01	80A4
17	299	1.2	RFV 302	83.81	80A4



$P_1 = 0.55 \text{ kW}$					
71B2 $n_1 = 2800 \text{ min}^{-1}$ 80A4 $n_1 = 1400 \text{ min}^{-1}$ 80B6 $n_1 = 900 \text{ min}^{-1}$					
n_2 min^{-1}	Mn_2 Nm	fs		i	
2.6	1844	1.2	RFV 503	339.66	80B6
2.9	1670	1.3	RFV 503	307.74	80B6
3.3	1501	0.8	RFV 403	430.24	80A4
3.5	1398	1.6	RFV 503	257.57	80B6
3.6	1359	0.9	RFV 403	250.36	80B6
3.9	1254	1.0	RFV 403	359.44	80A4
4.1	1185	1.9	RFV 503	339.66	80A4
4.4	1106	1.1	RFV 403	203.77	80B6
4.5	1074	2.0	RFV 503	307.74	80A4
4.6	1069	1.1	RFV 403	306.34	80A4
4.8	1021	1.2	RFV 403	188.04	80B6
5.1	962	2.3	RFV 503	177.23	80B6
5.3	925	1.3	RFV 403	265.04	80A4
5.4	899	2.4	RFV 503	257.57	80A4
5.6	874	1.4	RFV 403	250.36	80A4





Dati tecnici motoriduttori / Motor reducer technical data / Technische Daten der getriebemotoren

Caractéristiques techniques moto-reducteurs / Datos técnicos motorreductores / Características técnicas motoridutor

19



$P_1 = 0.55 \text{ kW}$					
71B2 $n_1 = 2800 \text{ min}^{-1}$ 80A4 $n_1 = 1400 \text{ min}^{-1}$ 80B6 $n_1 = 900 \text{ min}^{-1}$					
n_2 min^{-1}	Mn_2 Nm	fs		i	
18	279	1.3	RFV 302	50.38	80B6
18	276	2.2	RFV 353	158.39	71B2
19	266	2.3	RFV 352	47.93	80B6
19	257	1.4	RFV 302	72.11	80A4
19	251	2.4	RFV 353	71.90	80A4
20	250	0.8	RFV 252	45.12	80B6
20	247	1.4	RFV 302	44.56	80B6
20	244	2.5	RFV 352	68.58	80A4
21	239	1.5	RFV 302	67.01	80A4
22	225	0.8	RFV 252	40.56	80B6
22	229	2.6	RFV 352	41.24	80B6
22	225	1.6	RFV 302	63.01	80A4
23	219	0.9	RFV 252	61.56	80A4
23	209	1.7	RFV 303	119.64	71B2
24	205	1.0	RFV 253	117.60	71B2
24	206	1.7	RFV 302	57.66	80A4
25	202	3.0	RFV 352	56.66	80A4
25	199	3.0	RFV 352	35.88	80B6
26	192	1.0	RFV 252	53.89	80A4
26	192	1.8	RFV 302	34.71	80B6
27	180	1.9	RFV 303	102.94	71B2
27	185	3.2	RFV 352	33.38	80B6
28	176	1.1	RFV 252	49.39	80A4
28	180	1.9	RFV 302	50.38	80A4
29	170	1.0	RFV 252	30.61	80B6
30	162	1.2	RFV 253	92.72	71B2
30	168	2.1	RFV 302	30.28	80B6
31	161	1.2	RFV 252	45.12	80A4
31	159	2.2	RFV 302	44.56	80A4
33	149	2.3	RFV 302	83.81	71B2
34	147	2.4	RFV 302	26.46	80B6
35	145	1.3	RFV 252	40.56	80A4
35	144	2.4	RFV 302	40.34	80A4
36	139	1.4	RFV 252	78.17	71B2
38	130	2.6	RFV 302	23.40	80B6
39	129	2.7	RFV 302	72.11	71B2
39	128	1.2	RFV 252	23.04	80B6
39	127	1.6	RFV 252	71.42	71B2
40	125	1.5	RFV 252	34.96	80A4
40	124	2.8	RFV 302	34.71	80A4
42	119	2.9	RFV 302	67.01	71B2
44	112	3.1	RFV 302	63.01	71B2
45	112	1.4	RFV 252	20.17	80B6
45	112	3.0	RFV 302	20.14	80B6



$P_1 = 0.55 \text{ kW}$					
71B2 $n_1 = 2800 \text{ min}^{-1}$ 80A4 $n_1 = 1400 \text{ min}^{-1}$ 80B6 $n_1 = 900 \text{ min}^{-1}$					
n_2 min^{-1}	Mn_2 Nm	fs		i	
46	109	1.6	RFV 252	30.61	80A4
46	108	3.2	RFV 302	30.28	80A4
47	107	1.4	RFV 252	19.25	80B6
47	106	3.1	RFV 302	19.14	80B6
49	103	3.4	RFV 302	57.66	71B2
51	98	3.3	RFV 302	17.60	80B6
52	96	2.1	RFV 252	53.89	71B2
53	93	1.5	RFV 252	16.85	80B6
53	94	3.7	RFV 302	26.46	80A4
55	91	1.8	RFV 252	25.63	80A4
55	91	3.4	RFV 302	16.47	80B6
56	90	3.9	RFV 302	50.38	71B2
57	88	2.3	RFV 252	49.39	71B2
60	83	4.1	RFV 302	23.40	80A4
61	82	1.9	RFV 252	23.04	80A4
62	80	2.5	RFV 252	45.12	71B2
64	78	1.7	RFV 252	14.11	80B6
65	77	7.5	RFV 352	21.58	80A4
69	72	2.1	RFV 252	20.17	80A4
70	72	4.6	RFV 302	20.14	80A4
73	69	2.1	RFV 252	19.25	80A4
78	64	7.8	RFV 352	35.88	71B2
80	62	2.7	RFV 252	34.96	71B2
83	60	2.3	RFV 252	16.85	80A4
85	59	5.4	RFV 302	16.47	80A4
91	55	2.8	RFV 252	30.61	71B2
99	50	2.6	RFV 252	14.11	80A4
109	46	3.0	RFV 252	25.63	71B2
113	44	2.7	RFV 252	12.36	80A4
115	43	2.3	RFV 252	7.81	80B6
122	41	3.2	RFV 252	23.04	71B2
126	40	5.0	RFV 302	7.16	80B6
131	38	3.0	RFV 252	10.66	80A4
139	36	3.5	RFV 252	20.17	71B2
145	34	3.5	RFV 252	19.25	71B2
146	34	7.9	RFV 302	19.14	71B2
150	33	3.3	RFV 252	9.33	80A4
159	31	8.5	RFV 302	17.60	71B2
166	30	3.9	RFV 252	16.85	71B2
170	29	8.9	RFV 302	16.47	71B2
173	29	8.0	RFV 302	8.09	80A4
179	28	3.6	RFV 252	7.81	80A4
183	27	13.5	RFV 352	7.63	80A4
195	26	9.7	RFV 302	14.39	71B2





Dati tecnici motoriduttori / Motor reducer technical data / Technische Daten der getriebemotoren

Caractéristiques techniques moto-reducteurs / Datos técnicos motorreductores / Características técnicas motoridutor

$P_1 = 0.55 \text{ kW}$					
71B2 $n_1 = 2800 \text{ min}^{-1}$ 80A4 $n_1 = 1400 \text{ min}^{-1}$ 80B6 $n_1 = 900 \text{ min}^{-1}$					
n_2 min^{-1}	Mn_2 Nm	fs		i	
196	26	7.8	RFV 302	7.16	80A4
198	25	4.3	RFV 252	14.11	71B2
217	23	14.0	RFV 352	6.45	80A4
220	23	10.7	RFV 302	12.73	71B2
227	22	4.5	RFV 252	12.36	71B2
252	20	14.8	RFV 352	5.55	80A4
263	19	5.0	RFV 252	10.66	71B2
290	17	26.4	RFV 402	4.83	80A4
300	17	5.5	RFV 252	9.33	71B2
313	16	36.4	RFV 402	8.96	71B2
346	14	13.3	RFV 302	8.09	71B2
359	14	6.0	RFV 252	7.81	71B2
367	14	22.4	RFV 352	7.63	71B2
391	13	13.1	RFV 302	7.16	71B2
424	12	40.3	RFV 402	6.60	71B2
434	11	23.3	RFV 352	6.45	71B2
505	10	24.6	RFV 352	5.55	71B2
580	9	44.1	RFV 402	4.83	71B2

$P_1 = 0.75 \text{ kW}$					
80A2 $n_1 = 2800 \text{ min}^{-1}$ 80B4 $n_1 = 1400 \text{ min}^{-1}$ 90S6 $n_1 = 900 \text{ min}^{-1}$					
n_2 min^{-1}	Mn_2 Nm	fs		i	
7.6	877	2.5	RFV 503	184.38	80B4
7.8	855	1.4	RFV 403	359.44	80A2
7.9	843	2.6	RFV 503	177.23	80B4
8.2	810	1.5	RFV 403	170.24	80B4
8.5	780	2.8	RFV 503	105.43	90S6
8.7	762	1.6	RFV 403	160.26	80B4
8.7	764	2.9	RFV 503	160.57	80B4
8.8	754	0.8	RFV 353	158.39	80B4
8.9	750	1.6	RFV 403	101.27	90S6
9.0	742	3.0	RFV 503	155.95	80B4
9.1	729	1.6	RFV 403	306.34	80A2
9.4	707	3.1	RFV 503	95.52	90S6
9.5	703	0.9	RFV 353	147.71	80B4
9.5	703	1.7	RFV 403	147.71	80B4
9.9	672	3.3	RFV 503	141.30	80B4
10	660	1.8	RFV 403	138.65	80B4
10	639	3.4	RFV 503	134.39	80B4
11	623	1.0	RFV 353	130.87	80B4
11	599	2.0	RFV 403	125.89	80B4
11	615	3.0	RFV 502	81.31	90S6
12	553	2.2	RFV 403	74.67	90S6
12	557	3.1	RFV 502	73.67	90S6
13	527	1.1	RFV 353	110.69	80B4
13	518	1.2	RFV 352	68.58	90S6
13	518	2.3	RFV 403	108.91	80B4
14	490	1.2	RFV 353	102.89	80B4
14	482	2.5	RFV 403	101.27	80B4
15	453	1.3	RFV 353	95.25	80B4
15	447	2.7	RFV 403	188.04	80A2
16	436	0.8	RFV 302	57.66	90S6
16	428	1.4	RFV 352	56.66	90S6
16	432	2.8	RFV 402	57.20	90S6
17	407	0.9	RFV 302	83.81	80B4
17	381	3.1	RFV 403	160.26	80A2
18	381	0.9	RFV 302	50.38	90S6
19	350	1.0	RFV 302	72.11	80B4
19	342	1.8	RFV 353	71.90	80B4
19	355	3.4	RFV 403	74.67	80B4
20	337	1.0	RFV 302	44.56	90S6
20	333	1.8	RFV 352	68.58	80B4
20	333	3.6	RFV 402	68.47	80B4
21	326	1.1	RFV 302	67.01	80B4
22	306	1.1	RFV 302	63.01	80B4
22	305	1.1	RFV 302	40.34	90S6



$P_1 = 0.75 \text{ kW}$					
80A2 $n_1 = 2800 \text{ min}^{-1}$ 80B4 $n_1 = 1400 \text{ min}^{-1}$ 90S6 $n_1 = 900 \text{ min}^{-1}$					
n_2 min^{-1}	Mn_2 Nm	fs		i	
2.6	2514	0.9	RFV 503	339.66	90S6
2.9	2278	1.0	RFV 503	307.74	90S6
3.5	1906	1.2	RFV 503	257.57	90S6
4.1	1616	1.4	RFV 503	339.66	80B4
4.5	1464	1.5	RFV 503	307.74	80B4
4.6	1458	0.8	RFV 403	306.34	80B4
4.6	1442	1.5	RFV 503	194.88	90S6
4.8	1392	0.9	RFV 403	188.04	90S6
4.9	1365	1.6	RFV 503	184.38	90S6
5.1	1312	1.7	RFV 503	177.23	90S6
5.3	1261	1.0	RFV 403	265.04	80B4
5.4	1226	1.8	RFV 503	257.57	80B4
5.6	1191	1.0	RFV 403	250.36	80B4
5.6	1188	1.9	RFV 503	160.57	90S6
6.0	1108	2.0	RFV 503	232.84	80B4
6.1	1093	1.1	RFV 403	147.71	90S6
6.4	1046	2.1	RFV 503	141.30	90S6
6.6	1015	1.2	RFV 403	213.38	80B4
6.9	970	1.2	RFV 403	203.77	80B4
6.9	968	2.3	RFV 503	203.50	80B4
7.1	932	1.3	RFV 403	125.89	90S6
7.2	927	2.4	RFV 503	194.88	80B4
7.4	895	1.3	RFV 403	188.04	80B4





Dati tecnici motoriduttori / Motor reducer technical data / Technische Daten der getriebemotoren

Caractéristiques techniques moto-reducteurs / Datos técnicos motorreductores / Características técnicas motoridutor

19



$P_1 = 0.75 \text{ kW}$					
n_2 min ⁻¹	Mn_2 Nm	fs		i	
22	312	1.9	RFV 352	41.24	90S6
23	298	2.0	RFV 352	39.47	90S6
24	280	1.2	RFV 302	57.66	80B4
25	275	2.2	RFV 352	56.66	80B4
26	262	1.3	RFV 302	34.71	90S6
26	262	0.8	RFV 252	53.89	80B4
27	252	2.4	RFV 352	33.38	90S6
28	240	0.8	RFV 252	49.39	80B4
28	245	1.4	RFV 302	50.38	80B4
29	231	0.8	RFV 252	30.61	90S6
29	233	2.6	RFV 352	47.93	80B4
30	229	1.5	RFV 302	30.28	90S6
30	224	2.7	RFV 352	29.64	90S6
31	219	0.9	RFV 252	45.12	80B4
31	217	1.6	RFV 302	44.56	80B4
33	204	1.7	RFV 302	83.81	80A2
34	200	1.7	RFV 302	26.46	90S6
34	200	3.0	RFV 352	41.24	80B4
35	197	1.0	RFV 252	40.56	80B4
35	196	1.8	RFV 302	40.34	80B4
35	192	3.1	RFV 352	39.47	80B4
36	190	1.1	RFV 252	78.17	80A2
38	177	1.9	RFV 302	23.40	90S6
39	174	1.2	RFV 252	71.42	80A2
39	175	2.0	RFV 302	72.11	80A2
39	174	3.4	RFV 352	35.88	80B4
40	170	1.1	RFV 252	34.96	80B4
40	169	2.1	RFV 302	34.71	80B4
41	167	3.4	RFV 352	68.58	80A2
42	163	2.1	RFV 302	67.01	80A2
42	162	3.7	RFV 352	33.38	80B4
44	153	2.3	RFV 302	63.01	80A2
45	152	1.0	RFV 252	20.17	90S6
45	150	1.3	RFV 252	61.56	80A2
45	152	2.2	RFV 302	20.14	90S6
46	149	1.2	RFV 252	30.61	80B4
46	147	2.4	RFV 302	30.28	80B4
47	146	1.0	RFV 252	19.25	90S6
47	145	2.2	RFV 302	19.14	90S6
49	140	2.5	RFV 302	57.66	80A2
51	133	2.4	RFV 302	17.60	90S6
52	131	1.5	RFV 252	53.89	80A2
53	127	1.1	RFV 252	16.85	90S6
53	129	2.7	RFV 302	26.46	80B4



$P_1 = 0.75 \text{ kW}$					
n_2 min ⁻¹	Mn_2 Nm	fs		i	
55	125	1.3	RFV 252	25.63	80B4
55	125	2.5	RFV 302	16.47	90S6
56	122	2.9	RFV 302	50.38	80A2
57	120	1.7	RFV 252	49.39	80A2
60	114	3.0	RFV 302	23.40	80B4
61	112	1.4	RFV 252	23.04	80B4
62	110	1.8	RFV 252	45.12	80A2
63	109	2.8	RFV 302	14.39	90S6
64	107	1.2	RFV 252	14.11	90S6
69	98	1.5	RFV 252	20.17	80B4
70	98	3.4	RFV 302	20.14	80B4
73	94	1.6	RFV 252	19.25	80B4
80	85	2.0	RFV 252	34.96	80A2
80	86	3.7	RFV 302	17.60	80B4
81	84	3.8	RFV 302	34.71	80A2
83	82	1.7	RFV 252	16.85	80B4
84	81	1.4	RFV 252	10.66	90S6
85	80	3.9	RFV 302	16.47	80B4
91	74	2.1	RFV 252	30.61	80A2
96	71	1.5	RFV 252	9.33	90S6
99	69	1.9	RFV 252	14.11	80B4
106	64	4.5	RFV 302	26.46	80A2
109	62	2.2	RFV 252	25.63	80A2
110	62	4.7	RFV 302	12.73	80B4
113	60	2.0	RFV 252	12.36	80B4
115	59	1.7	RFV 252	7.81	90S6
120	57	5.0	RFV 302	23.40	80A2
122	56	2.3	RFV 252	23.04	80A2
126	54	3.7	RFV 302	7.16	90S6
130	52	5.2	RFV 302	10.76	80B4
131	52	2.2	RFV 252	10.66	80B4
139	49	2.6	RFV 252	20.17	80A2
145	47	2.6	RFV 252	19.25	80A2
150	45	2.4	RFV 252	9.33	80B4
156	44	16.0	RFV 402	8.96	80B4
159	43	6.2	RFV 302	17.60	80A2
162	42	7.0	RFV 352	5.55	90S6
166	41	2.8	RFV 252	16.85	80A2
170	40	6.6	RFV 302	16.47	80A2
179	38	2.7	RFV 252	7.81	80B4
183	37	9.9	RFV 352	7.63	80B4
196	35	5.7	RFV 302	7.16	80B4
198	34	3.2	RFV 252	14.11	80A2
212	32	17.7	RFV 402	6.60	80B4





Dati tecnici motoriduttori / Motor reducer technical data / Technische Daten der getriebemotoren

Caractéristiques techniques moto-reducteurs / Datos técnicos motorreductores / Características técnicas motoridutor

$P_1 = 0.75 \text{ kW}$					
80A2 $n_1 = 2800 \text{ min}^{-1}$ 80B4 $n_1 = 1400 \text{ min}^{-1}$ 90S6 $n_1 = 900 \text{ min}^{-1}$					
n_2 min^{-1}	Mn_2 Nm	f_s		i	
217	31	10.3	RFV 352	6.45	80B4
220	31	7.8	RFV 302	12.73	80A2
227	30	3.3	RFV 252	12.36	80A2
232	29	34.2	RFV 502	6.03	80B4
243	28	44.5	RFV 502	11.54	80A2
252	27	10.8	RFV 352	5.55	80B4
260	26	8.7	RFV 302	10.76	80A2
263	26	3.7	RFV 252	10.66	80A2
290	23	19.3	RFV 402	4.83	80B4
300	23	4.0	RFV 252	9.33	80A2
303	22	15.6	RFV 352	9.23	80A2
346	20	9.8	RFV 302	8.09	80A2
359	19	4.4	RFV 252	7.81	80A2
391	17	9.6	RFV 302	7.16	80A2
434	16	17.1	RFV 352	6.45	80A2
465	15	56.9	RFV 502	6.03	80A2
505	13	18.0	RFV 352	5.55	80A2
580	12	32.4	RFV 402	4.83	80A2

$P_1 = 1.1 \text{ kW}$					
80B2 $n_1 = 2800 \text{ min}^{-1}$ 90S4 $n_1 = 1400 \text{ min}^{-1}$ 90L6 $n_1 = 900 \text{ min}^{-1}$					
n_2 min^{-1}	Mn_2 Nm	f_s		i	
10	938	2.3	RFV 503	134.39	90S4
11	878	1.4	RFV 403	125.89	90S4
11	902	2.0	RFV 502	81.31	90L6
11	868	2.5	RFV 503	79.95	90L6
12	811	1.5	RFV 403	74.67	90L6
12	817	2.1	RFV 502	73.67	90L6
12	825	2.7	RFV 503	118.26	90S4
13	759	1.6	RFV 402	68.47	90L6
13	760	1.6	RFV 403	108.91	90S4
13	736	3.0	RFV 503	105.43	90S4
14	707	1.7	RFV 403	101.27	90S4
14	680	3.2	RFV 503	194.88	80B2
15	667	3.3	RFV 503	95.52	90S4
16	628	1.0	RFV 352	56.66	90L6
16	593	1.0	RFV 353	85.01	90S4
16	634	1.9	RFV 402	57.20	90L6
16	602	2.0	RFV 403	86.31	90S4
17	580	3.2	RFV 502	81.31	90S4
19	531	1.1	RFV 352	47.93	90L6
19	502	1.2	RFV 353	71.90	90S4
19	538	2.2	RFV 402	48.48	90L6
19	521	2.3	RFV 403	74.67	90S4
20	489	1.2	RFV 352	68.58	90S4
20	488	2.5	RFV 402	68.47	90S4
22	457	1.3	RFV 352	41.24	90L6
22	449	2.7	RFV 402	40.50	90L6
23	438	1.4	RFV 352	39.47	90L6
24	411	0.9	RFV 302	57.66	90S4
24	408	2.9	RFV 402	57.20	90S4
25	404	1.5	RFV 352	56.66	90S4
26	383	3.1	RFV 402	34.52	90L6
27	370	1.6	RFV 352	33.38	90L6
28	359	1.0	RFV 302	50.38	90S4
29	342	1.8	RFV 352	47.93	90S4
29	340	3.5	RFV 402	30.64	90L6
30	336	1.0	RFV 302	30.28	90L6
30	329	1.8	RFV 352	29.64	90L6
31	318	1.1	RFV 302	44.56	90S4
33	299	1.2	RFV 302	83.81	80B2
34	293	1.2	RFV 302	26.46	90L6
34	294	2.0	RFV 352	41.24	90S4
35	288	1.2	RFV 302	40.34	90S4
35	281	2.1	RFV 352	39.47	90S4
36	278	2.2	RFV 352	25.07	90L6



$P_1 = 1.1 \text{ kW}$					
80B2 $n_1 = 2800 \text{ min}^{-1}$ 90S4 $n_1 = 1400 \text{ min}^{-1}$ 90L6 $n_1 = 900 \text{ min}^{-1}$					
n_2 min^{-1}	Mn_2 Nm	f_s		i	
3.5	2796	0.8	RFV 503	257.57	90L6
4.1	2370	0.9	RFV 503	339.66	90S4
4.5	2147	1.0	RFV 503	307.74	90S4
4.6	2115	1.0	RFV 503	194.88	90L6
4.9	2001	1.1	RFV 503	184.38	90L6
5.1	1924	1.1	RFV 503	177.23	90L6
5.4	1797	1.2	RFV 503	257.57	90S4
6.0	1625	1.4	RFV 503	232.84	90S4
6.4	1534	1.4	RFV 503	141.30	90L6
6.7	1459	1.5	RFV 503	134.39	90L6
6.9	1420	1.5	RFV 503	203.50	90S4
7.2	1360	1.6	RFV 503	194.88	90S4
7.6	1287	1.7	RFV 503	184.38	90S4
7.9	1237	1.8	RFV 503	177.23	90S4
8.2	1188	1.0	RFV 403	170.24	90S4
8.5	1145	1.9	RFV 503	105.43	90L6
8.7	1118	1.1	RFV 403	160.26	90S4
8.7	1120	2.0	RFV 503	160.57	90S4
8.9	1099	1.1	RFV 403	101.27	90L6
9.0	1088	2.0	RFV 503	155.95	90S4
9.5	1031	1.2	RFV 403	147.71	90S4
9.9	986	2.2	RFV 503	141.30	90S4
10	968	1.2	RFV 403	138.65	90S4







Dati tecnici motoriduttori / Motor reducer technical data / Technische Daten der getriebemotoren

Caractéristiques techniques moto-reducteurs / Datos técnicos motorreductores / Características técnicas motoridutor

19

$P_1 = 1.1 \text{ kW}$ 80B2 $n_1 = 2800 \text{ min}^{-1}$ 90S4 $n_1 = 1400 \text{ min}^{-1}$ 90L6 $n_1 = 900 \text{ min}^{-1}$					
n_2 min ⁻¹	Mn_2 Nm	fs		i	
38	259	1.3	RFV 302	23.40	90L6
39	257	1.4	RFV 302	72.11	80B2
39	256	2.3	RFV 352	35.88	90S4
40	247	1.4	RFV 302	34.71	90S4
42	238	2.5	RFV 352	33.38	90S4
44	225	1.6	RFV 302	63.01	80B2
45	223	1.5	RFV 302	20.14	90L6
46	216	1.6	RFV 302	30.28	90S4
46	218	2.6	RFV 352	19.69	90L6
47	212	1.5	RFV 302	19.14	90L6
47	211	2.8	RFV 352	29.64	90S4
49	206	1.7	RFV 302	57.66	80B2
49	202	2.7	RFV 352	56.66	80B2
51	195	1.6	RFV 302	17.60	90L6
53	189	1.9	RFV 302	26.46	90S4
53	188	2.8	RFV 352	16.95	90L6
55	183	0.9	RFV 252	25.63	90S4
55	183	1.7	RFV 302	16.47	90L6
56	180	1.9	RFV 302	50.38	80B2
57	176	1.1	RFV 252	49.39	80B2
58	171	3.1	RFV 352	47.93	80B2
60	167	2.0	RFV 302	23.40	90S4
60	165	3.1	RFV 352	14.91	90L6
61	164	0.9	RFV 252	23.04	90S4
62	161	1.2	RFV 252	45.12	80B2
63	160	1.9	RFV 302	14.39	90L6
65	154	3.7	RFV 352	21.58	90S4
69	144	1.1	RFV 252	20.17	90S4
70	144	2.3	RFV 302	20.14	90S4
71	141	3.6	RFV 352	39.47	80B2
73	137	1.1	RFV 252	19.25	90S4
73	136	2.4	RFV 302	19.14	90S4
78	128	3.9	RFV 352	35.88	80B2
80	125	2.6	RFV 302	17.60	90S4
81	124	2.6	RFV 302	34.71	80B2
83	120	1.2	RFV 252	16.85	90S4
85	117	2.7	RFV 302	16.47	90S4
91	109	1.4	RFV 252	30.61	80B2
92	108	2.8	RFV 302	30.28	80B2
97	103	2.9	RFV 302	14.39	90S4
99	101	1.3	RFV 252	14.11	90S4
106	94	3.1	RFV 302	26.46	80B2
109	91	5.0	RFV 352	12.83	90S4
109	91	1.5	RFV 252	25.63	80B2

$P_1 = 1.1 \text{ kW}$ 80B2 $n_1 = 2800 \text{ min}^{-1}$ 90S4 $n_1 = 1400 \text{ min}^{-1}$ 90L6 $n_1 = 900 \text{ min}^{-1}$					
n_2 min ⁻¹	Mn_2 Nm	fs		i	
110	91	3.2	RFV 302	12.73	90S4
113	88	1.4	RFV 252	12.36	90S4
115	87	1.2	RFV 252	7.81	90L6
120	83	3.4	RFV 302	23.40	80B2
120	83	6.0	RFV 352	23.29	80B2
122	82	1.6	RFV 252	23.04	80B2
126	79	2.5	RFV 302	7.16	90L6
130	77	3.6	RFV 302	10.76	90S4
131	76	1.5	RFV 252	10.66	90S4
139	72	1.8	RFV 252	20.17	80B2
139	72	3.8	RFV 302	20.14	80B2
145	69	1.8	RFV 252	19.25	80B2
150	67	1.6	RFV 252	9.33	90S4
159	63	4.3	RFV 302	17.60	80B2
166	60	1.9	RFV 252	16.85	80B2
170	59	4.5	RFV 302	16.47	80B2
173	58	4.0	RFV 302	8.09	90S4
179	56	1.8	RFV 252	7.81	90S4
183	54	6.7	RFV 352	7.63	90S4
196	51	3.9	RFV 302	7.16	90S4
198	50	2.2	RFV 252	14.11	80B2
220	45	5.3	RFV 302	12.73	80B2
227	44	2.3	RFV 252	12.36	80B2
232	43	23.3	RFV 502	6.03	90S4
252	40	7.4	RFV 352	5.55	90S4
263	38	2.5	RFV 252	10.66	80B2
290	34	13.2	RFV 402	4.83	90S4
300	33	2.7	RFV 252	9.33	80B2
346	29	6.6	RFV 302	8.09	80B2
359	28	3.0	RFV 252	7.81	80B2
367	27	11.2	RFV 352	7.63	80B2
391	26	6.5	RFV 302	7.16	80B2
434	23	11.7	RFV 352	6.45	80B2
465	21	38.8	RFV 502	6.03	80B2
505	20	12.3	RFV 352	5.55	80B2
580	17	22.1	RFV 402	4.83	80B2



$P_1 = 1.5 \text{ kW}$ 90SA2 $n_1 = 2800 \text{ min}^{-1}$ 90LA4 $n_1 = 1400 \text{ min}^{-1}$ 100LA6 $n_1 = 900 \text{ min}^{-1}$					
n_2 min ⁻¹	Mn_2 Nm	fs		i	
4.5	2928	0.8	RFV 503	307.74	90LA4
4.6	2885	0.8	RFV 503	194.88	100LA6
4.9	2729	0.8	RFV 503	184.38	100LA6
5.1	2623	0.8	RFV 503	177.23	100LA6
5.4	2451	0.9	RFV 503	257.57	90LA4



Dati tecnici motoriduttori / Motor reducer technical data / Technische Daten der getriebemotoren

Caractéristiques techniques moto-reducteurs / Datos técnicos motorreductores / Características técnicas motoridutor

$P_1 = 1.5 \text{ kW}$					
90SA2 $n_1 = 2800 \text{ min}^{-1}$ 90LA4 $n_1 = 1400 \text{ min}^{-1}$ 100LA6 $n_1 = 900 \text{ min}^{-1}$					
n_2 min^{-1}	Mn_2 Nm	fs		i	
5.8	2309	1.0	RFV 503	155.95	100LA6
6.0	2216	1.0	RFV 503	232.84	90LA4
6.4	2092	1.1	RFV 503	141.30	100LA6
6.9	1937	1.1	RFV 503	203.50	90LA4
7.2	1854	1.2	RFV 503	194.88	90LA4
7.6	1754	1.3	RFV 503	184.38	90LA4
7.9	1686	1.3	RFV 503	177.23	90LA4
8.5	1561	1.4	RFV 503	105.43	100LA6
8.7	1528	1.4	RFV 503	160.57	90LA4
9.0	1484	1.5	RFV 503	155.95	90LA4
9.4	1414	1.6	RFV 503	95.52	100LA6
9.9	1345	1.6	RFV 503	141.30	90LA4
10	1319	0.9	RFV 403	138.65	90LA4
10	1279	1.7	RFV 503	134.39	90LA4
11	1198	1.0	RFV 403	125.89	90LA4
11	1229	1.5	RFV 502	81.31	100LA6
11	1183	1.9	RFV 503	79.95	100LA6
12	1125	2.0	RFV 503	118.26	90LA4
13	1035	1.2	RFV 402	68.47	100LA6
13	1036	1.2	RFV 403	108.91	90LA4
13	1003	2.2	RFV 503	105.43	90LA4
14	964	1.2	RFV 403	101.27	90LA4
15	909	2.4	RFV 503	95.52	90LA4
16	865	1.4	RFV 402	57.20	100LA6
16	821	1.5	RFV 403	86.31	90LA4
16	871	2.4	RFV 502	57.57	100LA6
17	790	2.3	RFV 502	81.31	90LA4
17	789	2.6	RFV 502	52.16	100LA6
18	761	2.9	RFV 503	79.95	90LA4
19	733	1.6	RFV 402	48.48	100LA6
19	711	1.7	RFV 403	74.67	90LA4
19	716	2.4	RFV 502	73.67	90LA4
20	667	0.9	RFV 352	68.58	90LA4
20	666	1.8	RFV 402	68.47	90LA4
21	623	1.0	RFV 353	130.87	90SA2
21	659	3.2	RFV 502	43.56	100LA6
22	624	1.0	RFV 352	41.24	100LA6
22	612	2.0	RFV 402	40.50	100LA6
23	597	1.0	RFV 352	39.47	100LA6
23	597	3.4	RFV 502	39.46	100LA6
24	556	2.2	RFV 402	57.20	90LA4
24	560	3.7	RFV 502	57.57	90LA4
25	527	1.1	RFV 353	110.69	90SA2
26	522	2.3	RFV 402	34.52	100LA6



$P_1 = 1.5 \text{ kW}$					
90SA2 $n_1 = 2800 \text{ min}^{-1}$ 90LA4 $n_1 = 1400 \text{ min}^{-1}$ 100LA6 $n_1 = 900 \text{ min}^{-1}$					
n_2 min^{-1}	Mn_2 Nm	fs		i	
27	505	1.2	RFV 352	33.38	100LA6
28	490	0.7	RFV 302	50.38	90LA4
29	471	2.5	RFV 402	48.48	90LA4
29	466	1.3	RFV 352	47.93	90LA4
29	463	2.6	RFV 402	30.64	100LA6
30	448	1.3	RFV 352	29.64	100LA6
33	404	1.5	RFV 353	85.01	90SA2
34	401	1.5	RFV 352	41.24	90LA4
34	395	2.8	RFV 402	26.12	100LA6
35	392	0.9	RFV 302	40.34	90LA4
35	384	1.6	RFV 352	39.47	90LA4
35	394	3.0	RFV 402	40.50	90LA4
36	379	1.6	RFV 352	25.07	100LA6
37	355	3.4	RFV 403	74.67	90SA2
38	354	1.0	RFV 302	23.40	100LA6
39	350	1.0	RFV 302	72.11	90SA2
39	349	1.7	RFV 352	35.88	90LA4
40	337	1.0	RFV 302	34.71	90LA4
41	336	3.6	RFV 402	34.52	90LA4
42	324	1.8	RFV 352	33.38	90LA4
44	306	1.1	RFV 302	63.01	90SA2
45	305	1.1	RFV 302	20.14	100LA6
46	294	1.2	RFV 302	30.28	90LA4
47	288	2.1	RFV 352	29.64	90LA4
48	283	7.4	RFV 502	29.12	90LA4
49	280	1.2	RFV 302	57.66	90SA2
49	275	2.0	RFV 352	56.66	90SA2
50	270	6.5	RFV 502	17.87	100LA6
51	266	1.2	RFV 302	17.60	100LA6
53	257	1.4	RFV 302	26.46	90LA4
53	256	2.0	RFV 352	16.95	100LA6
55	249	1.3	RFV 302	16.47	100LA6
56	244	2.5	RFV 352	25.07	90LA4
58	233	2.2	RFV 352	47.93	90SA2
60	227	1.5	RFV 302	23.40	90LA4
60	226	2.7	RFV 352	23.29	90LA4
63	217	1.6	RFV 302	44.56	90SA2
64	212	8.3	RFV 502	43.56	90SA2
65	210	2.7	RFV 352	21.58	90LA4
66	207	10.0	RFV 502	21.25	90LA4
68	200	2.5	RFV 352	41.24	90SA2
69	196	1.7	RFV 302	40.34	90SA2
70	196	1.7	RFV 302	20.14	90LA4
71	192	1.5	RFV 302	12.73	100LA6







Selezione motoriduttori / Motor reducer selection / Auswahl der getriebemotoren

Selection moto-reducteurs / Seleccion motorreductores / Seleção motoridutor

19

$P_1 = 1.5 \text{ kW}$					
90SA2 $n_1 = 2800 \text{ min}^{-1}$ 90LA4 $n_1 = 1400 \text{ min}^{-1}$ 100LA6 $n_1 = 900 \text{ min}^{-1}$					
n_2 min^{-1}	Mn_2 Nm	fs		i	
71	191	3.0	RFV 352	19.69	90LA4
73	186	1.7	RFV 302	19.14	90LA4
78	174	2.9	RFV 352	35.88	90SA2
80	170	1.0	RFV 252	34.96	90SA2
80	171	1.9	RFV 302	17.60	90LA4
83	165	3.1	RFV 352	16.95	90LA4
84	162	3.1	RFV 352	33.38	90SA2
85	160	2.0	RFV 302	16.47	90LA4
91	149	1.0	RFV 252	30.61	90SA2
92	147	2.1	RFV 302	30.28	90SA2
94	144	3.5	RFV 352	29.64	90SA2
97	140	2.1	RFV 302	14.39	90LA4
99	137	1.0	RFV 252	14.11	90LA4
100	137	6.3	RFV 402	14.06	90LA4
106	129	2.3	RFV 302	26.46	90SA2
109	125	1.1	RFV 252	25.63	90SA2
110	124	2.3	RFV 302	12.73	90LA4
111	122	1.9	RFV 302	8.09	100LA6
113	120	1.0	RFV 252	12.36	90LA4
115	118	6.6	RFV 402	12.17	90LA4
120	114	2.5	RFV 302	23.40	90SA2
122	112	1.2	RFV 252	23.04	90SA2
126	108	1.8	RFV 302	7.16	100LA6
130	105	2.6	RFV 302	10.76	90LA4
131	104	1.1	RFV 252	10.66	90LA4
139	98	1.3	RFV 252	20.17	90SA2
139	98	2.8	RFV 302	20.14	90SA2
142	96	5.0	RFV 352	19.69	90SA2
145	94	1.3	RFV 252	19.25	90SA2
146	93	2.9	RFV 302	19.14	90SA2
150	91	1.2	RFV 252	9.33	90LA4
151	90	2.8	RFV 302	9.26	90LA4
159	86	3.1	RFV 302	17.60	90SA2
166	82	1.4	RFV 252	16.85	90SA2
170	80	3.3	RFV 302	16.47	90SA2
173	79	2.9	RFV 302	8.09	90LA4
179	76	1.3	RFV 252	7.81	90LA4
183	74	4.9	RFV 352	7.63	90LA4
195	70	3.6	RFV 302	14.39	90SA2
196	70	2.9	RFV 302	7.16	90LA4
198	69	1.6	RFV 252	14.11	90SA2
220	62	3.9	RFV 302	12.73	90SA2
227	60	1.7	RFV 252	12.36	90SA2
230	59	11.0	RFV 402	12.17	90SA2



$P_1 = 1.5 \text{ kW}$					
90SA2 $n_1 = 2800 \text{ min}^{-1}$ 90LA4 $n_1 = 1400 \text{ min}^{-1}$ 100LA6 $n_1 = 900 \text{ min}^{-1}$					
n_2 min^{-1}	Mn_2 Nm	fs		i	
252	54	5.4	RFV 352	5.55	90LA4
260	52	4.4	RFV 302	10.76	90SA2
263	52	1.8	RFV 252	10.66	90SA2
290	47	9.7	RFV 402	4.83	90LA4
300	45	2.0	RFV 252	9.33	90SA2
303	45	7.8	RFV 352	9.23	90SA2
346	39	4.9	RFV 302	8.09	90SA2
359	38	2.2	RFV 252	7.81	90SA2
367	37	8.2	RFV 352	7.63	90SA2
391	35	4.8	RFV 302	7.16	90SA2
434	31	8.6	RFV 352	6.45	90SA2
465	29	28.5	RFV 502	6.03	90SA2
505	27	9.0	RFV 352	5.55	90SA2
580	23	16.2	RFV 402	4.83	90SA2

$P_1 = 1.85 \text{ kW}$					
90SB2 $n_1 = 2800 \text{ min}^{-1}$ 90LB4 $n_1 = 1400 \text{ min}^{-1}$ 100LB6 $n_1 = 900 \text{ min}^{-1}$					
n_2 min^{-1}	Mn_2 Nm	fs		i	
5.6	2931	0.8	RFV 503	160.57	100LB6
6.0	2733	0.8	RFV 503	232.84	90LB4
6.4	2580	0.9	RFV 503	141.30	100LB6
6.9	2388	0.9	RFV 503	203.50	90LB4
7.2	2287	1.0	RFV 503	194.88	90LB4
7.6	2164	1.0	RFV 503	184.38	90LB4
7.9	2080	1.1	RFV 503	177.23	90LB4
8.5	1925	1.1	RFV 503	105.43	100LB6
8.7	1884	1.2	RFV 503	160.57	90LB4
9.0	1830	1.2	RFV 503	155.95	90LB4
9.4	1744	1.3	RFV 503	95.52	100LB6
9.9	1658	1.3	RFV 503	141.30	90LB4
10	1577	1.4	RFV 503	134.39	90LB4
11	1516	1.2	RFV 502	81.31	100LB6
11	1460	1.5	RFV 503	79.95	100LB6
12	1374	1.3	RFV 502	73.67	100LB6
12	1388	1.6	RFV 503	118.26	90LB4
13	1252	1.0	RFV 403	213.38	90SB2
13	1237	1.8	RFV 503	105.43	90LB4
14	1189	1.0	RFV 403	101.27	90LB4
15	1121	2.0	RFV 503	95.52	90LB4
16	1067	1.1	RFV 402	57.20	100LB6
16	1013	1.2	RFV 403	86.31	90LB4
16	1074	1.9	RFV 502	57.57	100LB6
17	975	1.9	RFV 502	81.31	90LB4
18	938	2.3	RFV 503	79.95	90LB4
19	904	1.3	RFV 402	48.48	100LB6



Selezione motoriduttori / Motor reducer selection / Auswahl der getriebemotoren
 Selection moto-reducteurs / Selección motorreductores / Seleção motoridutor





$P_1 = 1.85 \text{ kW}$					
n_2 min ⁻¹	Mn_2 Nm	fs		i	
19	876	1.4	RFV 403	74.67	90LB4
19	883	1.9	RFV 502	73.67	90LB4
20	821	1.5	RFV 402	68.47	90LB4
20	829	2.7	RFV 503	141.30	90SB2
21	812	2.6	RFV 502	43.56	100LB6
22	755	1.6	RFV 402	40.50	100LB6
23	736	2.8	RFV 502	39.46	100LB6
24	686	1.8	RFV 402	57.20	90LB4
24	690	3.0	RFV 502	57.57	90LB4
25	679	0.9	RFV 352	56.66	90LB4
26	644	1.9	RFV 402	34.52	100LB6
27	625	3.2	RFV 502	52.16	90LB4
27	604	1.0	RFV 353	102.89	90SB2
28	594	2.0	RFV 403	101.27	90SB2
29	575	1.0	RFV 352	47.93	90LB4
29	581	2.1	RFV 402	48.48	90LB4
30	553	1.1	RFV 352	29.64	100LB6
32	506	2.4	RFV 403	86.31	90SB2
33	499	1.2	RFV 353	85.01	90SB2
34	494	1.2	RFV 352	41.24	90LB4
34	487	2.3	RFV 402	26.12	100LB6
35	473	1.3	RFV 352	39.47	90LB4
35	486	2.5	RFV 402	40.50	90LB4
36	468	1.3	RFV 352	25.07	100LB6
37	438	2.7	RFV 403	74.67	90SB2
39	430	1.4	RFV 352	35.88	90LB4
40	421	2.5	RFV 402	22.60	100LB6
41	411	1.4	RFV 352	68.58	90SB2
41	414	2.9	RFV 402	34.52	90LB4
42	400	1.5	RFV 352	33.38	90LB4
46	363	1.0	RFV 302	30.28	90LB4
46	367	1.6	RFV 352	19.69	100LB6
46	367	3.3	RFV 402	30.64	90LB4
47	355	1.7	RFV 352	29.64	90LB4
49	346	1.0	RFV 302	57.66	90SB2
49	340	1.6	RFV 352	56.66	90SB2
51	328	1.0	RFV 302	17.60	100LB6
53	317	1.1	RFV 302	26.46	90LB4
53	316	1.6	RFV 352	16.95	100LB6
55	308	3.2	RFV 402	16.50	100LB6
55	307	1.0	RFV 302	16.47	100LB6
56	302	1.2	RFV 302	50.38	90SB2
56	301	2.0	RFV 352	25.07	90LB4
58	287	1.8	RFV 352	47.93	90SB2

$P_1 = 1.85 \text{ kW}$					
n_2 min ⁻¹	Mn_2 Nm	fs		i	
60	281	1.2	RFV 302	23.40	90LB4
60	279	2.1	RFV 352	23.29	90LB4
63	268	1.1	RFV 302	14.39	100LB6
63	267	1.3	RFV 302	44.56	90SB2
64	262	3.3	RFV 402	14.06	100LB6
65	259	2.2	RFV 352	21.58	90LB4
68	247	2.0	RFV 352	41.24	90SB2
69	242	1.4	RFV 302	40.34	90SB2
70	241	1.4	RFV 302	20.14	90LB4
70	239	1.9	RFV 352	12.83	100LB6
71	237	1.2	RFV 302	12.73	100LB6
71	236	2.4	RFV 352	19.69	90LB4
73	229	1.4	RFV 302	19.14	90LB4
78	215	2.3	RFV 352	35.88	90SB2
80	211	1.5	RFV 302	17.60	90LB4
81	208	1.5	RFV 302	34.71	90SB2
83	203	2.5	RFV 352	16.95	90LB4
84	201	1.4	RFV 302	10.76	100LB6
84	200	2.5	RFV 352	33.38	90SB2
85	197	1.6	RFV 302	16.47	90LB4
92	182	1.7	RFV 302	30.28	90SB2
94	179	2.9	RFV 352	14.91	90LB4
97	173	1.5	RFV 302	9.26	100LB6
97	173	1.7	RFV 302	14.39	90LB4
98	172	2.4	RFV 352	9.23	100LB6
106	159	1.8	RFV 302	26.46	90SB2
109	154	3.0	RFV 352	12.83	90LB4
110	153	1.9	RFV 302	12.73	90LB4
111	151	1.5	RFV 302	8.09	100LB6
118	142	2.6	RFV 352	7.63	100LB6
120	140	2.0	RFV 302	23.40	90SB2
124	135	6.4	RFV 402	22.60	90SB2
126	134	1.5	RFV 302	7.16	100LB6
130	129	2.1	RFV 302	10.76	90LB4
139	121	1.0	RFV 252	20.17	90SB2
139	121	2.3	RFV 302	20.14	90SB2
140	120	2.7	RFV 352	6.45	100LB6
145	115	1.1	RFV 252	19.25	90SB2
146	115	2.4	RFV 302	19.14	90SB2
150	112	1.0	RFV 252	9.33	90LB4
151	111	2.3	RFV 302	9.26	90LB4
159	106	2.5	RFV 302	17.60	90SB2
162	104	2.8	RFV 352	5.55	100LB6
166	101	1.2	RFV 252	16.85	90SB2







$P_1 = 1.85 \text{ kW}$					
90SB2 $n_1 = 2800 \text{ min}^{-1}$ 90LB4 $n_1 = 1400 \text{ min}^{-1}$ 100LB6 $n_1 = 900 \text{ min}^{-1}$					
n_2 min^{-1}	Mn_2 Nm	fs		i	
170	99	2.7	RFV 302	16.47	90SB2
173	97	2.4	RFV 302	8.09	90LB4
179	94	1.1	RFV 252	7.81	90LB4
196	86	2.3	RFV 302	7.16	90LB4
198	85	1.3	RFV 252	14.11	90SB2
217	77	4.2	RFV 352	6.45	90LB4
220	76	3.2	RFV 302	12.73	90SB2
227	74	1.3	RFV 252	12.36	90SB2
252	67	4.4	RFV 352	5.55	90LB4
260	64	3.5	RFV 302	10.76	90SB2
263	64	1.5	RFV 252	10.66	90SB2
290	58	7.8	RFV 402	4.83	90LB4
300	56	1.6	RFV 252	9.33	90SB2
302	56	3.8	RFV 302	9.26	90SB2
346	48	4.0	RFV 302	8.09	90SB2
359	47	1.8	RFV 252	7.81	90SB2
391	43	3.9	RFV 302	7.16	90SB2
465	36	23.1	RFV 502	6.03	90SB2
505	33	7.3	RFV 352	5.55	90SB2
580	29	13.1	RFV 402	4.83	90SB2



$P_1 = 2.2 \text{ kW}$					
90L2 $n_1 = 2800 \text{ min}^{-1}$ 100LA4 $n_1 = 1400 \text{ min}^{-1}$					
n_2 min^{-1}	Mn_2 Nm	fs		i	
19	1050	1.6	RFV 502	73.67	100LA4
20	976	1.2	RFV 402	68.47	100LA4
20	986	2.2	RFV 503	141.30	90L2
21	938	2.3	RFV 503	134.39	90L2
22	878	1.4	RFV 403	125.89	90L2
24	815	1.5	RFV 402	57.20	100LA4
24	821	2.5	RFV 502	57.57	100LA4
25	772	0.8	RFV 353	110.69	90L2
26	760	1.6	RFV 403	108.91	90L2
27	744	2.7	RFV 502	52.16	100LA4
28	707	1.7	RFV 403	101.27	90L2
29	683	0.9	RFV 352	47.93	100LA4
29	691	1.7	RFV 402	48.48	100LA4
32	602	2.0	RFV 403	86.31	90L2
32	621	3.4	RFV 502	43.56	100LA4
33	593	1.0	RFV 353	85.01	90L2
34	588	1.0	RFV 352	41.24	100LA4
35	563	1.1	RFV 352	39.47	100LA4
35	577	2.1	RFV 402	40.50	100LA4
37	521	2.3	RFV 403	74.67	90L2
39	512	1.2	RFV 352	35.88	100LA4
41	489	1.2	RFV 352	68.58	90L2
41	492	2.4	RFV 402	34.52	100LA4
42	476	1.3	RFV 352	33.38	100LA4
46	437	2.7	RFV 402	30.64	100LA4
47	423	1.4	RFV 352	29.64	100LA4
49	404	1.3	RFV 352	56.66	90L2
49	408	2.7	RFV 402	57.20	90L2
53	377	0.9	RFV 302	26.46	100LA4
54	372	3.0	RFV 402	26.12	100LA4
56	359	1.0	RFV 302	50.38	90L2
56	357	1.7	RFV 352	25.07	100LA4
58	342	1.5	RFV 352	47.93	90L2
60	334	1.0	RFV 302	23.40	100LA4
60	332	1.8	RFV 352	23.29	100LA4
62	322	3.2	RFV 402	22.60	100LA4
63	318	1.1	RFV 302	44.56	90L2
65	308	1.9	RFV 352	21.58	100LA4
68	294	1.7	RFV 352	41.24	90L2
69	288	1.2	RFV 302	40.34	90L2
70	287	1.1	RFV 302	20.14	100LA4
71	281	1.8	RFV 352	39.47	90L2
71	281	2.0	RFV 352	19.69	100LA4
73	273	1.2	RFV 302	19.14	100LA4

$P_1 = 2.2 \text{ kW}$					
90L2 $n_1 = 2800 \text{ min}^{-1}$ 100LA4 $n_1 = 1400 \text{ min}^{-1}$					
n_2 min^{-1}	Mn_2 Nm	fs		i	
6.9	2840	0.8	RFV 503	203.50	100LA4
7.2	2720	0.8	RFV 503	194.88	100LA4
7.6	2573	0.9	RFV 503	184.38	100LA4
7.9	2473	0.9	RFV 503	177.23	100LA4
8.7	2241	1.0	RFV 503	160.57	100LA4
9.0	2177	1.0	RFV 503	155.95	100LA4
9.9	1972	1.1	RFV 503	141.30	100LA4
10	1876	1.2	RFV 503	134.39	100LA4
12	1651	1.3	RFV 503	118.26	100LA4
13	1472	1.5	RFV 503	105.43	100LA4
14	1422	0.8	RFV 403	203.77	90L2
14	1420	1.5	RFV 503	203.50	90L2
15	1312	0.9	RFV 403	188.04	90L2
15	1333	1.7	RFV 503	95.52	100LA4
16	1188	1.0	RFV 403	170.24	90L2
16	1237	1.8	RFV 503	177.23	90L2
17	1118	1.1	RFV 403	160.26	90L2
17	1159	1.6	RFV 502	81.31	100LA4
17	1120	2.0	RFV 503	160.57	90L2
18	1116	2.0	RFV 503	79.95	100LA4
19	1031	1.2	RFV 403	147.71	90L2



$P_1 = 2.2 \text{ kW}$					
90L2 $n_1 = 2800 \text{ min}^{-1}$ 100LA4 $n_1 = 1400 \text{ min}^{-1}$					
n_2 min^{-1}	Mn_2 Nm	fs		i	
78	256	2.0	RFV 352	35.88	90L2
80	251	1.3	RFV 302	17.60	100LA4
81	247	1.3	RFV 302	34.71	90L2
83	242	2.1	RFV 352	16.95	100LA4
84	238	2.1	RFV 352	33.38	90L2
85	235	1.3	RFV 302	16.47	100LA4
97	205	1.5	RFV 302	14.39	100LA4
100	200	4.3	RFV 402	14.06	100LA4
106	189	1.5	RFV 302	26.46	90L2
109	183	2.5	RFV 352	12.83	100LA4
110	181	1.6	RFV 302	12.73	100LA4
112	179	2.8	RFV 352	25.07	90L2
120	167	1.7	RFV 302	23.40	90L2
122	164	0.8	RFV 252	23.04	90L2
130	154	3.1	RFV 352	21.58	90L2
130	153	1.8	RFV 302	10.76	100LA4
139	144	1.9	RFV 302	20.14	90L2
142	140	3.4	RFV 352	19.69	90L2
146	136	2.0	RFV 302	19.14	90L2
151	132	1.9	RFV 302	9.26	100LA4
152	132	3.2	RFV 352	9.23	100LA4
159	125	2.1	RFV 302	17.60	90L2
165	121	3.6	RFV 352	16.95	90L2
166	120	1.0	RFV 252	16.85	90L2
170	117	2.2	RFV 302	16.47	90L2
173	115	2.0	RFV 302	8.09	100LA4
183	109	3.4	RFV 352	7.63	100LA4
188	106	4.0	RFV 352	14.91	90L2
195	103	2.4	RFV 302	14.39	90L2
196	102	2.0	RFV 302	7.16	100LA4
198	101	1.1	RFV 252	14.11	90L2
217	92	3.5	RFV 352	6.45	100LA4
220	91	2.7	RFV 302	12.73	90L2
227	88	1.1	RFV 252	12.36	90L2
252	79	3.7	RFV 352	5.55	100LA4
260	77	3.0	RFV 302	10.76	90L2
263	76	1.3	RFV 252	10.66	90L2
290	69	6.6	RFV 402	4.83	100LA4
300	67	1.4	RFV 252	9.33	90L2
302	66	3.2	RFV 302	9.26	90L2
346	58	3.3	RFV 302	8.09	90L2
359	56	1.5	RFV 252	7.81	90L2
367	54	5.6	RFV 352	7.63	90L2
391	51	3.3	RFV 302	7.16	90L2

$P_1 = 2.2 \text{ kW}$					
90L2 $n_1 = 2800 \text{ min}^{-1}$ 100LA4 $n_1 = 1400 \text{ min}^{-1}$					
n_2 min^{-1}	Mn_2 Nm	fs		i	
424	47	10.1	RFV 402	6.60	90L2
434	46	5.8	RFV 352	6.45	90L2
465	43	19.4	RFV 502	6.03	90L2
505	40	6.2	RFV 352	5.55	90L2
580	34	11.0	RFV 402	4.83	90L2



$P_1 = 3.0 \text{ kW}$					
100L2 $n_1 = 2800 \text{ min}^{-1}$ 100LB4 $n_1 = 1400 \text{ min}^{-1}$ 132S6 $n_1 = 900 \text{ min}^{-1}$					
n_2 min^{-1}	Mn_2 Nm	fs		i	
9.1	2928	0.8	RFV 503	307.74	100L2
9.9	2689	0.8	RFV 503	141.30	100LB4
10	2558	0.9	RFV 503	134.39	100LB4
11	2451	0.9	RFV 503	257.57	100L2
12	2251	1.0	RFV 503	118.26	100LB4
13	2007	1.1	RFV 503	105.43	100LB4
14	1937	1.1	RFV 503	203.50	100L2
15	1818	1.2	RFV 503	95.52	100LB4
16	1741	1.2	RFV 502	57.57	132S6
17	1581	1.2	RFV 502	81.31	100LB4
17	1528	1.4	RFV 503	160.57	100L2
18	1522	1.4	RFV 503	79.95	100LB4
19	1432	1.2	RFV 502	73.67	100LB4
20	1331	0.9	RFV 402	68.47	100LB4
20	1345	1.6	RFV 503	141.30	100L2
21	1317	1.6	RFV 502	43.56	132S6
21	1279	1.7	RFV 503	134.39	100L2
22	1225	1.0	RFV 402	40.50	132S6
23	1193	1.7	RFV 502	39.46	132S6
24	1112	1.1	RFV 402	57.20	100LB4
24	1119	1.8	RFV 502	57.57	100LB4
26	1044	1.1	RFV 402	34.52	132S6
27	1014	2.0	RFV 502	52.16	100LB4
28	972	2.4	RFV 502	32.14	132S6
29	942	1.3	RFV 402	48.48	100LB4
29	909	2.4	RFV 503	95.52	100L2
31	881	2.4	RFV 502	29.12	132S6
32	847	2.5	RFV 502	43.56	100LB4
34	790	1.4	RFV 402	26.12	132S6
34	790	2.2	RFV 502	81.31	100L2
35	787	1.5	RFV 402	40.50	100LB4
35	767	2.7	RFV 502	39.46	100LB4
38	722	3.1	RFV 502	37.14	100LB4
39	698	0.9	RFV 352	35.88	100LB4
40	683	1.5	RFV 402	22.60	132S6
41	671	1.8	RFV 402	34.52	100LB4





Dati tecnici motoriduttori / Motor reducer technical data / Technische Daten der getriebemotoren



Caractéristiques techniques moto-reducteurs / Datos técnicos motorreductores / Características técnicas motoridutor



19

$P_1 = 3.0 \text{ kW}$ 100L2 $n_1 = 2800 \text{ min}^{-1}$ 100LB4 $n_1 = 1400 \text{ min}^{-1}$ 132S6 $n_1 = 900 \text{ min}^{-1}$					
n_2 min ⁻¹	Mn_2 Nm	fs		i	
42	649	0.9	RFV 352	33.38	100LB4
44	625	3.7	RFV 502	32.14	100LB4
46	595	1.0	RFV 352	19.69	132S6
46	596	2.0	RFV 402	30.64	100LB4
47	576	1.0	RFV 352	29.64	100LB4
49	551	1.0	RFV 352	56.66	100L2
49	556	2.0	RFV 402	57.20	100L2
50	540	3.2	RFV 502	17.87	132S6
53	513	1.0	RFV 352	16.95	132S6
54	508	2.2	RFV 402	26.12	100LB4
55	499	2.0	RFV 402	16.50	132S6
56	487	1.2	RFV 352	25.07	100LB4
58	466	1.1	RFV 352	47.93	100L2
58	471	2.2	RFV 402	48.48	100L2
60	453	1.3	RFV 352	23.29	100LB4
62	439	2.4	RFV 402	22.60	100LB4
64	425	2.0	RFV 402	14.06	132S6
65	420	1.4	RFV 352	21.58	100LB4
66	410	3.3	RFV 502	13.55	132S6
68	401	1.2	RFV 352	41.24	100L2
69	394	2.5	RFV 402	40.50	100L2
70	392	0.8	RFV 302	20.14	100LB4
70	388	1.2	RFV 352	12.83	132S6
71	383	1.5	RFV 352	19.69	100LB4
71	384	2.7	RFV 402	19.75	100LB4
73	372	0.9	RFV 302	19.14	100LB4
74	368	2.1	RFV 402	12.17	132S6
78	349	1.4	RFV 352	35.88	100L2
80	342	0.9	RFV 302	17.60	100LB4
81	336	3.0	RFV 402	34.52	100L2
83	330	1.6	RFV 352	16.95	100LB4
84	324	1.5	RFV 352	33.38	100L2
84	324	2.4	RFV 402	10.72	132S6
85	320	1.0	RFV 302	16.47	100LB4
85	321	3.0	RFV 402	16.50	100LB4
92	294	1.0	RFV 302	30.28	100L2
93	292	4.7	RFV 502	9.66	132S6
94	290	1.8	RFV 352	14.91	100LB4
97	280	1.1	RFV 302	14.39	100LB4
98	279	1.5	RFV 352	9.23	132S6
100	271	2.6	RFV 402	8.96	132S6
106	257	1.1	RFV 302	26.46	100L2
109	249	1.8	RFV 352	12.83	100LB4
110	247	1.2	RFV 302	12.73	100LB4



$P_1 = 3.0 \text{ kW}$ 100L2 $n_1 = 2800 \text{ min}^{-1}$ 100LB4 $n_1 = 1400 \text{ min}^{-1}$ 132S6 $n_1 = 900 \text{ min}^{-1}$					
n_2 min ⁻¹	Mn_2 Nm	fs		i	
112	244	2.1	RFV 352	25.07	100L2
115	237	3.3	RFV 402	12.17	100LB4
120	227	1.2	RFV 302	23.40	100L2
120	226	2.2	RFV 352	23.29	100L2
130	210	2.3	RFV 352	21.58	100L2
130	209	1.3	RFV 302	10.76	100LB4
136	200	2.9	RFV 402	6.60	132S6
139	196	1.4	RFV 302	20.14	100L2
140	195	1.7	RFV 352	6.45	132S6
142	191	2.5	RFV 352	19.69	100L2
146	186	1.5	RFV 302	19.14	100L2
151	180	1.4	RFV 302	9.26	100LB4
152	179	2.3	RFV 352	9.23	100LB4
159	171	1.6	RFV 302	17.60	100L2
161	169	3.0	RFV 402	5.58	132S6
162	168	1.7	RFV 352	5.55	132S6
165	165	2.6	RFV 352	16.95	100L2
170	160	1.6	RFV 302	16.47	100L2
173	157	1.5	RFV 302	8.09	100LB4
183	148	2.5	RFV 352	7.63	100LB4
188	145	2.9	RFV 352	14.91	100L2
195	140	1.8	RFV 302	14.39	100L2
196	139	1.4	RFV 302	7.16	100LB4
199	137	5.3	RFV 402	14.06	100L2
217	125	2.6	RFV 352	6.45	100LB4
218	125	3.1	RFV 352	12.83	100L2
220	124	2.0	RFV 302	12.73	100L2
230	118	5.5	RFV 402	12.17	100L2
251	108	4.7	RFV 402	5.58	100LB4
252	108	2.7	RFV 352	5.55	100LB4
260	105	2.2	RFV 302	10.76	100L2
290	94	4.8	RFV 402	4.83	100LB4
302	90	2.4	RFV 302	9.26	100L2
313	87	6.7	RFV 402	8.96	100L2
346	79	2.4	RFV 302	8.09	100L2
367	74	4.1	RFV 352	7.63	100L2
391	70	2.4	RFV 302	7.16	100L2
434	63	4.3	RFV 352	6.45	100L2
505	54	4.5	RFV 352	5.55	100L2
580	47	8.1	RFV 402	4.83	100L2







$P_1 = 4.0 \text{ kW}$					
112M2 $n_1 = 2800 \text{ min}^{-1}$ 112M4 $n_1 = 1400 \text{ min}^{-1}$					
n_2 min^{-1}	Mn_2 Nm	fs		i	
13	2675	0.8	RFV 503	105.43	112M4
14	2582	0.9	RFV 503	203.50	112M2
15	2424	0.9	RFV 503	95.52	112M4
16	2249	1.0	RFV 503	177.23	112M2
17	2108	0.9	RFV 502	81.31	112M4
18	2029	1.1	RFV 503	79.95	112M4
19	1910	0.9	RFV 502	73.67	112M4
20	1793	1.2	RFV 503	141.30	112M2
21	1705	1.3	RFV 503	134.39	112M2
24	1483	0.8	RFV 402	57.20	112M4
24	1492	1.4	RFV 502	57.57	112M4
27	1352	1.5	RFV 502	52.16	112M4
29	1257	1.0	RFV 402	48.48	112M4
29	1212	1.8	RFV 503	95.52	112M2
32	1129	1.9	RFV 502	43.56	112M4
34	1054	1.7	RFV 502	81.31	112M2
35	1050	1.1	RFV 402	40.50	112M4
35	1023	2.0	RFV 502	39.46	112M4
38	963	2.3	RFV 502	37.14	112M4
41	895	1.3	RFV 402	34.52	112M4
44	833	2.8	RFV 502	32.14	112M4
46	794	1.5	RFV 402	30.64	112M4
47	768	0.8	RFV 352	29.64	112M4
48	755	2.8	RFV 502	29.12	112M4
49	746	2.4	RFV 502	57.57	112M2
49	741	1.5	RFV 402	57.20	112M2
54	677	1.6	RFV 402	26.12	112M4
54	676	2.5	RFV 502	52.16	112M2
56	650	0.9	RFV 352	25.07	112M4
58	628	1.7	RFV 402	48.48	112M2
60	604	1.0	RFV 352	23.29	112M4
62	586	1.8	RFV 402	22.60	112M4
64	565	3.1	RFV 502	43.56	112M2
65	559	1.0	RFV 352	21.58	112M4
68	534	0.9	RFV 352	41.24	112M2
69	525	1.9	RFV 402	40.50	112M2
70	522	0.6	RFV 302	20.14	112M4
71	510	1.1	RFV 352	19.69	112M4
71	512	2.0	RFV 402	19.75	112M4
78	465	1.1	RFV 352	35.88	112M2
81	447	2.2	RFV 402	34.52	112M2
83	439	1.2	RFV 352	16.95	112M4
84	433	1.2	RFV 352	33.38	112M2
85	428	2.3	RFV 402	16.50	112M4

$P_1 = 4.0 \text{ kW}$					
112M2 $n_1 = 2800 \text{ min}^{-1}$ 112M4 $n_1 = 1400 \text{ min}^{-1}$					
n_2 min^{-1}	Mn_2 Nm	fs		i	
91	397	2.5	RFV 402	30.64	112M2
92	392	0.8	RFV 302	30.28	112M2
94	386	1.3	RFV 352	14.91	112M4
94	384	1.3	RFV 352	29.64	112M2
97	373	0.8	RFV 302	14.39	112M4
100	365	2.4	RFV 402	14.06	112M4
107	338	2.7	RFV 402	26.12	112M2
109	333	1.4	RFV 352	12.83	112M4
110	330	0.9	RFV 302	12.73	112M4
112	325	1.5	RFV 352	25.07	112M2
115	315	2.5	RFV 402	12.17	112M4
120	302	1.7	RFV 352	23.29	112M2
124	293	3.0	RFV 402	22.60	112M2
130	279	1.0	RFV 302	10.76	112M4
130	280	1.7	RFV 352	21.58	112M2
131	278	2.8	RFV 402	10.72	112M4
139	261	1.1	RFV 302	20.14	112M2
142	255	1.9	RFV 352	19.69	112M2
146	248	1.1	RFV 302	19.14	112M2
151	240	1.1	RFV 302	9.26	112M4
152	239	1.8	RFV 352	9.23	112M4
156	232	3.0	RFV 402	8.96	112M4
159	228	1.2	RFV 302	17.60	112M2
165	220	2.0	RFV 352	16.95	112M2
170	213	1.2	RFV 302	16.47	112M2
173	210	1.1	RFV 302	8.09	112M4
183	198	1.9	RFV 352	7.63	112M4
188	193	2.2	RFV 352	14.91	112M2
195	187	1.3	RFV 302	14.39	112M2
196	186	1.1	RFV 302	7.16	112M4
199	182	4.0	RFV 402	14.06	112M2
212	171	3.3	RFV 402	6.60	112M4
217	167	1.9	RFV 352	6.45	112M4
218	166	2.3	RFV 352	12.83	112M2
220	165	1.5	RFV 302	12.73	112M2
230	158	4.1	RFV 402	12.17	112M2
252	144	2.0	RFV 352	5.55	112M4
260	139	1.6	RFV 302	10.76	112M2
290	125	3.6	RFV 402	4.83	112M4
302	120	1.8	RFV 302	9.26	112M2
303	120	2.9	RFV 352	9.23	112M2
346	105	1.8	RFV 302	8.09	112M2
367	99	3.1	RFV 352	7.63	112M2
391	93	1.8	RFV 302	7.16	112M2







$P_1 = 4.0 \text{ kW}$ 112M2 $n_1 = 2800 \text{ min}^{-1}$ 112M4 $n_1 = 1400 \text{ min}^{-1}$					
n_2 min ⁻¹	Mn_2 Nm	fs		i	
424	86	5.5	RFV 402	6.60	112M2
434	84	3.2	RFV 352	6.45	112M2
465	78	10.7	RFV 502	6.03	112M2
505	72	3.4	RFV 352	5.55	112M2



$P_1 = 5.5 \text{ kW}$ 132SA2 $n_1 = 2800 \text{ min}^{-1}$ 132S4 $n_1 = 1400 \text{ min}^{-1}$ 132MB6 $n_1 = 900 \text{ min}^{-1}$					
n_2 min ⁻¹	Mn_2 Nm	fs		i	
83	604	0.9	RFV 352	16.95	132S4
84	595	0.8	RFV 352	33.38	132SA2
84	594	1.3	RFV 402	10.72	132MB6
85	588	1.7	RFV 402	16.50	132S4
86	577	2.8	RFV 502	16.19	132S4
91	546	1.8	RFV 402	30.64	132SA2
93	535	2.6	RFV 502	9.66	132MB6
94	531	1.0	RFV 352	14.91	132S4
96	519	3.4	RFV 502	29.12	132SA2
98	512	0.8	RFV 352	9.23	132MB6
100	501	1.7	RFV 402	14.06	132S4
103	483	2.8	RFV 502	13.55	132S4
107	465	2.0	RFV 402	26.12	132SA2
109	457	1.0	RFV 352	12.83	132S4
109	457	2.6	RFV 502	8.24	132MB6
110	454	3.4	RFV 502	12.73	132S4
112	447	1.1	RFV 352	25.07	132SA2
115	434	1.8	RFV 402	12.17	132S4
118	423	1.5	RFV 402	7.63	132MB6
120	415	1.2	RFV 352	23.29	132SA2
121	411	3.6	RFV 502	11.54	132S4
124	403	2.2	RFV 402	22.60	132SA2
128	391	2.8	RFV 502	7.06	132MB6
130	385	1.3	RFV 352	21.58	132SA2
131	382	2.0	RFV 402	10.72	132S4
136	366	1.6	RFV 402	6.60	132MB6
140	358	0.9	RFV 352	6.45	132MB6
142	351	1.4	RFV 352	19.69	132SA2
145	344	4.0	RFV 502	9.66	132S4
149	334	3.0	RFV 502	6.03	132MB6
152	329	1.3	RFV 352	9.23	132S4
156	319	2.2	RFV 402	8.96	132S4
161	309	1.6	RFV 402	5.58	132MB6
162	308	0.9	RFV 352	5.55	132MB6
165	302	1.4	RFV 352	16.95	132SA2
170	294	2.8	RFV 402	16.50	132SA2
183	272	1.3	RFV 352	7.63	132S4
183	272	2.3	RFV 402	7.63	132S4
186	268	1.7	RFV 402	4.83	132MB6
188	266	1.6	RFV 352	14.91	132SA2
199	251	2.9	RFV 402	14.06	132SA2
212	235	2.4	RFV 402	6.60	132S4
217	230	1.4	RFV 352	6.45	132S4
218	229	1.7	RFV 352	12.83	132SA2

$P_1 = 5.5 \text{ kW}$ 132SA2 $n_1 = 2800 \text{ min}^{-1}$ 132S4 $n_1 = 1400 \text{ min}^{-1}$ 132MB6 $n_1 = 900 \text{ min}^{-1}$					
n_2 min ⁻¹	Mn_2 Nm	fs		i	
21	2415	0.9	RFV 502	43.56	132MB6
23	2188	0.9	RFV 502	39.46	132MB6
24	2052	1.0	RFV 502	57.57	132S4
27	1859	1.1	RFV 502	52.16	132S4
28	1782	1.3	RFV 502	32.14	132MB6
31	1615	1.3	RFV 502	29.12	132MB6
32	1553	1.4	RFV 502	43.56	132S4
34	1466	1.5	RFV 502	26.43	132MB6
35	1443	0.8	RFV 402	40.50	132S4
35	1407	1.5	RFV 502	39.46	132S4
38	1324	1.7	RFV 502	37.14	132S4
40	1253	0.8	RFV 402	22.60	132MB6
41	1230	1.0	RFV 402	34.52	132S4
42	1178	1.8	RFV 502	21.25	132MB6
44	1146	2.0	RFV 502	32.14	132S4
46	1092	1.1	RFV 402	30.64	132S4
48	1038	2.0	RFV 502	29.12	132S4
49	1026	1.7	RFV 502	57.57	132SA2
50	991	1.8	RFV 502	17.87	132MB6
53	942	2.3	RFV 502	26.43	132S4
54	931	1.2	RFV 402	26.12	132S4
55	915	1.1	RFV 402	16.50	132MB6
56	898	1.8	RFV 502	16.19	132MB6
58	864	1.2	RFV 402	48.48	132SA2
60	836	2.6	RFV 502	23.45	132S4
62	805	1.3	RFV 402	22.60	132S4
64	780	1.1	RFV 402	14.06	132MB6
64	776	2.3	RFV 502	43.56	132SA2
66	757	2.7	RFV 502	21.25	132S4
69	722	1.4	RFV 402	40.50	132SA2
71	702	0.8	RFV 352	19.69	132S4
71	704	1.5	RFV 402	19.75	132S4
74	675	1.2	RFV 402	12.17	132MB6
75	662	2.8	RFV 502	37.14	132SA2
78	639	0.8	RFV 352	35.88	132SA2
78	637	2.7	RFV 502	17.87	132S4
81	615	1.6	RFV 402	34.52	132SA2



$P_1 = 5.5 \text{ kW}$		132SA2 $n_1 = 2800 \text{ min}^{-1}$ 132S4 $n_1 = 1400 \text{ min}^{-1}$ 132MB6 $n_1 = 900 \text{ min}^{-1}$			
n_2 min^{-1}	Mn_2 Nm	f_s		i	
230	217	3.0	RFV 402	12.17	132SA2
251	199	2.5	RFV 402	5.58	132S4
252	198	1.5	RFV 352	5.55	132S4
261	191	3.3	RFV 402	10.72	132SA2
290	172	2.6	RFV 402	4.83	132S4
303	164	2.1	RFV 352	9.23	132SA2
313	160	3.6	RFV 402	8.96	132SA2
340	147	6.8	RFV 502	8.24	132SA2
367	136	2.2	RFV 352	7.63	132SA2
397	126	7.2	RFV 502	7.06	132SA2
424	118	4.0	RFV 402	6.60	132SA2
434	115	2.3	RFV 352	6.45	132SA2
465	107	7.8	RFV 502	6.03	132SA2
505	99	2.5	RFV 352	5.55	132SA2
580	86	4.4	RFV 402	4.83	132SA2

$P_1 = 7.5 \text{ kW}$		132SB2 $n_1 = 2800 \text{ min}^{-1}$ 132MA4 $n_1 = 1400 \text{ min}^{-1}$			
n_2 min^{-1}	Mn_2 Nm	f_s		i	
96	708	2.5	RFV 502	29.12	132SB2
100	683	1.3	RFV 402	14.06	132MA4
103	659	2.0	RFV 502	13.55	132MA4
106	642	2.9	RFV 502	26.43	132SB2
107	635	1.4	RFV 402	26.12	132SB2
110	619	2.5	RFV 502	12.73	132MA4
112	609	0.8	RFV 352	25.07	132SB2
115	591	1.3	RFV 402	12.17	132MA4
120	566	0.9	RFV 352	23.29	132SB2
121	561	2.7	RFV 502	11.54	132MA4
124	549	1.6	RFV 402	22.60	132SB2
130	524	0.9	RFV 352	21.58	132SB2
131	521	1.5	RFV 402	10.72	132MA4
142	478	1.0	RFV 352	19.69	132SB2
142	480	1.8	RFV 402	19.75	132SB2
145	469	2.9	RFV 502	9.66	132MA4
152	449	0.9	RFV 352	9.23	132MA4
156	435	1.6	RFV 402	8.96	132MA4
165	412	1.0	RFV 352	16.95	132SB2
170	401	2.0	RFV 402	16.50	132SB2
170	401	3.0	RFV 502	8.24	132MA4
173	393	3.4	RFV 502	16.19	132SB2
183	371	1.0	RFV 352	7.63	132MA4
183	371	1.7	RFV 402	7.63	132MA4
188	362	1.2	RFV 352	14.91	132SB2
198	343	3.2	RFV 502	7.06	132MA4
199	342	2.1	RFV 402	14.06	132SB2
207	329	3.4	RFV 502	13.55	132SB2
212	321	1.8	RFV 402	6.60	132MA4
217	313	1.0	RFV 352	6.45	132MA4
218	312	1.2	RFV 352	12.83	132SB2
230	296	2.2	RFV 402	12.17	132SB2
232	293	3.4	RFV 502	6.03	132MA4
251	271	1.9	RFV 402	5.58	132MA4
252	270	1.1	RFV 352	5.55	132MA4
261	261	2.4	RFV 402	10.72	132SB2
290	235	1.9	RFV 402	4.83	132MA4
303	224	1.6	RFV 352	9.23	132SB2
313	218	2.7	RFV 402	8.96	132SB2
340	200	5.0	RFV 502	8.24	132SB2
367	185	1.6	RFV 352	7.63	132SB2
397	172	5.3	RFV 502	7.06	132SB2
424	161	3.0	RFV 402	6.60	132SB2
434	157	1.7	RFV 352	6.45	132SB2



$P_1 = 7.5 \text{ kW}$		132SB2 $n_1 = 2800 \text{ min}^{-1}$ 132MA4 $n_1 = 1400 \text{ min}^{-1}$			
n_2 min^{-1}	Mn_2 Nm	f_s		i	
27	2535	0.8	RFV 502	52.16	132MA4
32	2117	1.0	RFV 502	43.56	132MA4
35	1918	1.1	RFV 502	39.46	132MA4
38	1805	1.2	RFV 502	37.14	132MA4
44	1562	1.5	RFV 502	32.14	132MA4
46	1489	0.8	RFV 402	30.64	132MA4
48	1415	1.5	RFV 502	29.12	132MA4
49	1399	1.3	RFV 502	57.57	132SB2
53	1285	1.7	RFV 502	26.43	132MA4
54	1269	0.9	RFV 402	26.12	132MA4
54	1268	1.3	RFV 502	52.16	132SB2
58	1178	0.9	RFV 402	48.48	132SB2
60	1140	1.9	RFV 502	23.45	132MA4
62	1098	0.9	RFV 402	22.60	132MA4
64	1059	1.7	RFV 502	43.56	132SB2
66	1033	2.0	RFV 502	21.25	132MA4
69	984	1.0	RFV 402	40.50	132SB2
71	960	1.1	RFV 402	19.75	132MA4
71	959	1.8	RFV 502	39.46	132SB2
75	902	2.0	RFV 502	37.14	132SB2
78	869	2.0	RFV 502	17.87	132MA4
81	839	1.2	RFV 402	34.52	132SB2
85	802	1.2	RFV 402	16.50	132MA4
86	787	2.0	RFV 502	16.19	132MA4
87	781	2.4	RFV 502	32.14	132SB2
91	745	1.3	RFV 402	30.64	132SB2







Dati tecnici motoriduttori / Motor reducer technical data / Technische Daten der getriebemotoren



Caractéristiques techniques moto-reducteurs / Datos técnicos motorreductores / Características técnicas motoridutor

19



$P_1 = 7.5 \text{ kW}$		132SB2 $n_1 = 2800 \text{ min}^{-1}$ 132MA4 $n_1 = 1400 \text{ min}^{-1}$			
n_2 min^{-1}	Mn_2 Nm	fs		i	
465	146	5.7	RFV 502	6.03	132SB2
505	135	1.8	RFV 352	5.55	132SB2
580	117	3.2	RFV 402	4.83	132SB2



$P_1 = 9.2 \text{ kW}$		132SM2 $n_1 = 2800 \text{ min}^{-1}$ 132MB4 $n_1 = 1400 \text{ min}^{-1}$			
n_2 min^{-1}	Mn_2 Nm	fs		i	
157	533	2.7	RFV 502	17.87	132SM2
165	505	0.9	RFV 352	16.95	132SM2
170	492	2.4	RFV 502	8.24	132MB4
173	483	2.8	RFV 502	16.19	132SM2
183	455	1.4	RFV 402	7.63	132MB4
188	444	1.0	RFV 352	14.91	132SM2
198	421	2.6	RFV 502	7.06	132MB4
207	404	2.8	RFV 502	13.55	132SM2
212	394	1.4	RFV 402	6.60	132MB4
217	385	0.8	RFV 352	6.45	132MB4
218	382	1.0	RFV 352	12.83	132SM2
220	380	3.4	RFV 502	12.73	132SM2
230	363	1.8	RFV 402	12.17	132SM2
232	359	2.8	RFV 502	6.03	132MB4
243	344	3.6	RFV 502	11.54	132SM2
251	333	1.5	RFV 402	5.58	132MB4
252	331	0.9	RFV 352	5.55	132MB4
261	320	2.0	RFV 402	10.72	132SM2
290	288	1.6	RFV 402	4.83	132MB4
303	275	1.3	RFV 352	9.23	132SM2
313	267	2.2	RFV 402	8.96	132SM2
340	246	4.1	RFV 502	8.24	132SM2
367	227	1.3	RFV 352	7.63	132SM2
397	210	4.3	RFV 502	7.06	132SM2
424	197	2.4	RFV 402	6.60	132SM2
434	192	1.4	RFV 352	6.45	132SM2
465	180	4.6	RFV 502	6.03	132SM2
502	166	2.5	RFV 402	5.58	132SM2
505	165	1.5	RFV 352	5.55	132SM2
580	144	2.6	RFV 402	4.83	132SM2



$P_1 = 9.2 \text{ kW}$		132SM2 $n_1 = 2800 \text{ min}^{-1}$ 132MB4 $n_1 = 1400 \text{ min}^{-1}$			
n_2 min^{-1}	Mn_2 Nm	fs		i	
32	2597	0.8	RFV 502	43.56	132MB4
35	2353	0.9	RFV 502	39.46	132MB4
38	2214	1.0	RFV 502	37.14	132MB4
44	1916	1.2	RFV 502	32.14	132MB4
48	1736	1.2	RFV 502	29.12	132MB4
49	1716	1.0	RFV 502	57.57	132SM2
53	1576	1.4	RFV 502	26.43	132MB4
54	1555	1.1	RFV 502	52.16	132SM2
60	1398	1.6	RFV 502	23.45	132MB4
62	1347	0.8	RFV 402	22.60	132MB4
64	1298	1.4	RFV 502	43.56	132SM2
66	1267	1.6	RFV 502	21.25	132MB4
69	1207	0.8	RFV 402	40.50	132SM2
71	1177	0.9	RFV 402	19.75	132MB4
71	1176	1.5	RFV 502	39.46	132SM2
75	1107	1.7	RFV 502	37.14	132SM2
78	1065	1.6	RFV 502	17.87	132MB4
81	1029	1.0	RFV 402	34.52	132SM2
85	984	1.0	RFV 402	16.50	132MB4
86	965	1.7	RFV 502	16.19	132MB4
87	958	2.0	RFV 502	32.14	132SM2
91	913	1.1	RFV 402	30.64	132SM2
96	868	2.0	RFV 502	29.12	132SM2
100	838	1.0	RFV 402	14.06	132MB4
103	808	1.7	RFV 502	13.55	132MB4
106	788	2.3	RFV 502	26.43	132SM2
107	779	1.2	RFV 402	26.12	132SM2
110	759	2.0	RFV 502	12.73	132MB4
115	725	1.1	RFV 402	12.17	132MB4
119	699	2.6	RFV 502	23.45	132SM2
121	688	2.2	RFV 502	11.54	132MB4
124	674	1.3	RFV 402	22.60	132SM2
131	639	1.2	RFV 402	10.72	132MB4
132	633	2.7	RFV 502	21.25	132SM2
142	589	1.5	RFV 402	19.75	132SM2
145	576	2.4	RFV 502	9.66	132MB4
152	550	0.8	RFV 352	9.23	132MB4
156	534	1.3	RFV 402	8.96	132MB4



$P_1 = 11 \text{ kW}$		160MR2 $n_1 = 2800 \text{ min}^{-1}$ 160MR4 $n_1 = 1400 \text{ min}^{-1}$ 160L6 $n_1 = 900 \text{ min}^{-1}$			
n_2 min^{-1}	Mn_2 Nm	fs		i	
34	2931	0.8	RFV 502	26.43	160L6
38	2647	0.8	RFV 502	37.14	160MR4
42	2356	0.9	RFV 502	21.25	160L6
44	2291	1.0	RFV 502	32.14	160MR4
48	2076	1.0	RFV 502	29.12	160MR4
49	2052	0.9	RFV 502	57.57	160MR2
50	1982	0.9	RFV 502	17.87	160L6
53	1884	1.2	RFV 502	26.43	160MR4
54	1859	0.9	RFV 502	52.16	160MR2
56	1795	0.9	RFV 502	16.19	160L6
60	1672	1.3	RFV 502	23.45	160MR4



$P_1 = 11 \text{ kW}$					
n_2 min ⁻¹	Mn_2 Nm	fs		i	
160MR2 $n_1 = 2800 \text{ min}^{-1}$ 160MR4 $n_1 = 1400 \text{ min}^{-1}$ 160L6 $n_1 = 900 \text{ min}^{-1}$					
64	1553	1.1	RFV 502	43.56	160MR2
66	1515	1.4	RFV 502	21.25	160MR4
71	1412	1.1	RFV 502	12.73	160L6
75	1324	1.4	RFV 502	37.14	160MR2
78	1274	1.4	RFV 502	17.87	160MR4
86	1154	1.4	RFV 502	16.19	160MR4
87	1146	1.7	RFV 502	32.14	160MR2
93	1071	1.3	RFV 502	9.66	160L6
96	1038	1.7	RFV 502	29.12	160MR2
103	966	1.4	RFV 502	13.55	160MR4
106	942	2.0	RFV 502	26.43	160MR2
109	914	1.3	RFV 502	8.24	160L6
110	908	1.7	RFV 502	12.73	160MR4
119	836	2.2	RFV 502	23.45	160MR2
121	822	1.8	RFV 502	11.54	160MR4
128	783	1.4	RFV 502	7.06	160L6
132	757	2.3	RFV 502	21.25	160MR2
145	688	2.0	RFV 502	9.66	160MR4
149	668	1.5	RFV 502	6.03	160L6
157	637	2.3	RFV 502	17.87	160MR2
170	588	2.0	RFV 502	8.24	160MR4
173	577	2.3	RFV 502	16.19	160MR2
198	503	2.2	RFV 502	7.06	160MR4
207	483	2.3	RFV 502	13.55	160MR2
220	454	2.8	RFV 502	12.73	160MR2
232	430	2.3	RFV 502	6.03	160MR4
243	411	3.0	RFV 502	11.54	160MR2
290	344	3.3	RFV 502	9.66	160MR2
340	294	3.4	RFV 502	8.24	160MR2
397	252	3.6	RFV 502	7.06	160MR2
465	215	3.9	RFV 502	6.03	160MR2

$P_1 = 15 \text{ kW}$					
n_2 min ⁻¹	Mn_2 Nm	fs		i	
160MB2 $n_1 = 2800 \text{ min}^{-1}$ 160L4 $n_1 = 1400 \text{ min}^{-1}$ 180L6 $n_1 = 900 \text{ min}^{-1}$					
87	1562	1.2	RFV 502	32.14	160MB2
93	1460	0.9	RFV 502	9.66	180L6
96	1415	1.2	RFV 502	29.12	160MB2
103	1317	1.0	RFV 502	13.55	160L4
106	1285	1.4	RFV 502	26.43	160MB2
109	1247	1.0	RFV 502	8.24	180L6
110	1238	1.2	RFV 502	12.73	160L4
119	1140	1.6	RFV 502	23.45	160MB2
121	1121	1.3	RFV 502	11.54	160L4
128	1067	1.0	RFV 502	7.06	180L6
132	1033	1.7	RFV 502	21.25	160MB2
145	939	1.5	RFV 502	9.66	160L4
149	911	1.1	RFV 502	6.03	180L6
157	869	1.7	RFV 502	17.87	160MB2
170	801	1.5	RFV 502	8.24	160L4
173	787	1.7	RFV 502	16.19	160MB2
198	686	1.6	RFV 502	7.06	160L4
207	659	1.7	RFV 502	13.55	160MB2
220	619	2.1	RFV 502	12.73	160MB2
232	586	1.7	RFV 502	6.03	160L4
243	561	2.2	RFV 502	11.54	160MB2
290	469	2.4	RFV 502	9.66	160MB2
340	401	2.5	RFV 502	8.24	160MB2
397	343	2.6	RFV 502	7.06	160MB2
465	293	2.8	RFV 502	6.03	160MB2

$P_1 = 15 \text{ kW}$					
n_2 min ⁻¹	Mn_2 Nm	fs		i	
160MB2 $n_1 = 2800 \text{ min}^{-1}$ 160L4 $n_1 = 1400 \text{ min}^{-1}$ 180L6 $n_1 = 900 \text{ min}^{-1}$					
53	2569	0.9	RFV 502	26.43	160L4
54	2535	0.7	RFV 502	52.16	160MB2
56	2448	0.7	RFV 502	16.19	180L6
60	2280	1.0	RFV 502	23.45	160L4
64	2117	0.8	RFV 502	43.56	160MB2
66	2066	1.0	RFV 502	21.25	160L4
71	1918	0.9	RFV 502	39.46	160MB2
75	1805	1.0	RFV 502	37.14	160MB2
78	1737	1.0	RFV 502	17.87	160L4
86	1574	1.0	RFV 502	16.19	160L4



$P_1 = 18.5 \text{ kW}$					
n_2 min ⁻¹	Mn_2 Nm	fs		i	
160L2 $n_1 = 2800 \text{ min}^{-1}$ 180M4 $n_1 = 1400 \text{ min}^{-1}$					
60	2812	0.8	RFV 502	23.45	180M4
66	2548	0.8	RFV 502	21.25	180M4
75	2226	0.8	RFV 502	37.14	160L2
78	2142	0.8	RFV 502	17.87	180M4
86	1941	0.8	RFV 502	16.19	180M4
87	1927	1.0	RFV 502	32.14	160L2
96	1746	1.0	RFV 502	29.12	160L2
103	1625	0.8	RFV 502	13.55	180M4
106	1584	1.2	RFV 502	26.43	160L2
110	1526	1.0	RFV 502	12.73	180M4
119	1406	1.3	RFV 502	23.45	160L2
121	1383	1.1	RFV 502	11.54	180M4
132	1274	1.4	RFV 502	21.25	160L2
145	1158	1.2	RFV 502	9.66	180M4
157	1071	1.4	RFV 502	17.87	160L2
170	988	1.2	RFV 502	8.24	180M4





Dati tecnici motoriduttori / Motor reducer technical data / Technische Daten der getriebemotoren

Caractéristiques techniques moto-réducteurs / Datos técnicos motorreductores / Características técnicas motoridutor

19

$P_1 = 18.5 \text{ kW}$					
		160L2 $n_1 = 2800 \text{ min}^{-1}$		180M4 $n_1 = 1400 \text{ min}^{-1}$	
n_2 min^{-1}	Mn_2 Nm	fs		i	
173	971	1.4	RFV 502	16.19	160L2
198	846	1.3	RFV 502	7.06	180M4
207	812	1.4	RFV 502	13.55	160L2
220	763	1.7	RFV 502	12.73	160L2
232	723	1.4	RFV 502	6.03	180M4
243	691	1.8	RFV 502	11.54	160L2
290	579	2.0	RFV 502	9.66	160L2
340	494	2.0	RFV 502	8.24	160L2
397	423	2.1	RFV 502	7.06	160L2
465	361	2.3	RFV 502	6.03	160L2

$P_1 = 22 \text{ kW}$					
		180M2 $n_1 = 2800 \text{ min}^{-1}$		180L4 $n_1 = 1400 \text{ min}^{-1}$	
n_2 min^{-1}	Mn_2 Nm	fs		i	
87	2291	0.8	RFV 502	32.14	180M2
96	2076	0.8	RFV 502	29.12	180M2
106	1884	1.0	RFV 502	26.43	180M2
110	1815	0.8	RFV 502	12.73	180L4
119	1672	1.1	RFV 502	23.45	180M2
121	1645	0.9	RFV 502	11.54	180L4
132	1515	1.1	RFV 502	21.25	180M2
145	1377	1.0	RFV 502	9.66	180L4
157	1274	1.1	RFV 502	17.87	180M2
170	1175	1.0	RFV 502	8.24	180L4
173	1154	1.2	RFV 502	16.19	180M2
198	1006	1.1	RFV 502	7.06	180L4
207	966	1.2	RFV 502	13.55	180M2
220	908	1.4	RFV 502	12.73	180M2
232.3	859	1.2	RFV 502	6.03	180L4
243	822	1.5	RFV 502	11.54	180M2
290	688	1.7	RFV 502	9.66	180M2
340	588	1.7	RFV 502	8.24	180M2
397	503	1.8	RFV 502	7.06	180M2
465	430	1.9	RFV 502	6.03	180M2



Flangia entrata / Input flange / Antriebsflansch
 Bride d'entrée / Brida entrada / Flange de entrada

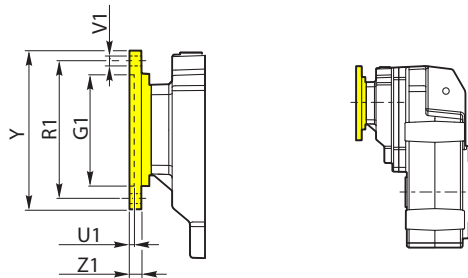

RFV	IEC	G ₁	R ₁	U ₁	V ₁			Y	Z ₁	
					∅					
252	90 B5	130	165	4.5	11	8		200	10	
	90 B14	95	115	4	8.5	8		140	10	
	80 B5	130	165	4.5	11	8		200	10	
	80B14	80	100	4	7		4	120	10	
	71 B5	110	130	4.5	9	8		160	10	
	71 B14	70	85	3.5	7		4	105	10	
	63 B5	95	115	4	8.5	8		140	10	
253	71 B5	110	130	4.5	9	8		160	10	
	71 B14	70	85	3.5	7		4	105	8	
	63 B5	95	115	4	9	8		140	9	
	63 B14	60	75	3.5	6		4	90	8	
	56 B5	80	100	4	7	8		120	9	
	56 B14	50	65	3.5	6		4	80	8	
302	100/112 B5	180	215	5	14	8		250	14.5	
	100/112 B14	110	130	5	9	8		160	12	
	90 B5	130	165	4.5	11	8		200	10	
	90 B14	95	115	4	8.5	8		140	10	
	80 B5	130	165	4.5	11	8		200	10	
	80 B14	80	100	4	7		4	120	10	
	71 B5	110	130	4.5	9	8		160	10	
	71 B14	70	85	3.5	7		4	105	10	
	63 B5	95	115	4	8.5	8		140	10	
303	71 B5	110	130	4.5	9	8		160	10	
	71 B14	70	85	3.5	7		4	105	8	
	63 B5	95	115	4	9	8		140	9	
	63 B14	60	75	3.5	6		4	90	8	
	56 B5	80	100	4	7	8		120	9	
	56 B14	50	65	3.5	6		4	80	8	
352	132 B5	230	265	5	M12	4		300	16	
	132 B14	130	165	5	11	4		200	12	
	100/112 B5	180	215	5	14	8		250	14.5	
	100/112 B14	110	130	5	9	8		160	12	
	90 B5	130	165	4.5	11	8		200	10	
	90 B14	95	115	4	8.5	8		140	10	
	80 B5	130	165	4.5	11	8		200	10	
	80 B14	80	100	4	7		4	120	10	
	71 B5	110	130	4.5	9	8		160	10	
	71 B14	70	85	3.5	7		4	105	10	
	63 B5	95	115	4	8.5	8		140	10	
353	90 B5	130	165	4.5	11	8		200	10	
	90 B14	95	115	4	8.5	8		140	10	
	80 B5	130	165	4.5	11	8		200	10	
	80B14	80	100	4	7		4	120	10	
	71 B5	110	130	4.5	9	8		160	10	
	71 B14	70	85	3.5	7		4	105	10	
	63 B5	95	115	4	8.5	8		140	10	
RFV	IEC	G ₁	R ₁	U ₁	V ₁			Y	Z ₁	
402	132 B5	230	265	5	M12	4		300	16	
	132 B14	130	165	5	11	4		200	12	
	100/112 B5	180	215	5	14	8		250	14.5	
	100/112 B14	110	130	5	9	8		160	12	
	90 B5	130	165	5	11	8		200	12.5	
	90 B14	95	115	4	9		4	140	12	
	80 B5	130	165	5	11	8		200	12.5	
	71 B5	110	130	5	9	8		160	12	
	403	90 B5	130	165	4.5	11	8		160	10
		90 B14	95	115	4	8.5	8		105	10
80 B5		130	165	4.5	11	8		140	10	
80 B14		80	100	4	7		4	120	10	
71 B5		110	130	4.5	9	8		90	10	
71 B14		70	85	3.5	7		4	120	10	
63 B5		95	115	4	8.5	8		80	10	
502	180 B5	250	300	6	M16	4		350	20	
	160 B5	250	300	6	M16	4		350	20	
	132 B5	230	265	5	M12	4		300	16	
	132 B14	130	165	5	11	4		200	12	
	100/112 B5	180	215	5	M12	4		250	15	
	90 B5	130	165	5	11	4		200	12	
	80 B5	130	165	5	11	4		200	12	
	503	100/112 B5	180	215	5	14	8		250	14.5
100/112 B14		110	130	5	9	8		160	12	
90 B5		130	165	5	11	8		200	12.5	
90 B14		95	115	4	9		4	140	12	
80 B5		130	165	5	11	8		200	12.5	
71 B5	110	130	5	9	8		160	12		



Dimensioni / Dimensions / Abmessungen

Dimensions/ Dimensiones / Dimensões

Flangia entrata / Input flange / Antriebsflansch

Bride d'entrée / Brida entrada / Flange de entrada

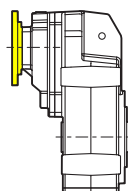
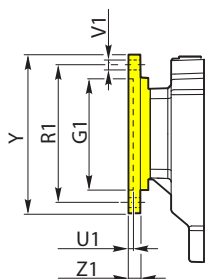

RFV	NEMA	G ₁	R ₁	U ₁	V ₁			Y	Z ₁
					∅				
252	140 TC	114.3	149.22	5.5	10.5	4		165.1	12
	56 C								
253	56 C	114.3	149.22	5.5	10.5	4		165.1	12
302	140 TC	114.3	149.22	5.5	10.5	4		165.1	12
	56 C								
303	56 C	114.3	149.22	5.5	10.5	4		165.1	12
352	180 TC	215.9	184.15	6	14	4		228.6	15
	140 TC								
	56 C	114.3	149.22	5.5	10.5	4		165.1	12
353	140 TC	114.3	149.22	5.5	10.5	4		165.1	12
	56 C								
402	210 TC	215.9	184.15	6	14	4		228.6	15
	180 TC								
	140 TC								
403	140 TC	114.3	149.22	5.5	10.5	4		165.1	12
	56 C								
502	280 TC	266.7	228.6	6	14	4		285.75	17
	250 TC								16
	210 TC	215.9	184.15	6	14	4		228.6	15
	180 TC								
	140 TC	114.3	149.22	5.5	11	4		165.1	12
503	180 TC	215.9	184.15	6	14	4		228.6	15
	140 TC	114.3	149.22	5.5	11	4		165.1	12



RFV



Dati tecnici riduttori / Reducer technical data / Technische Daten Getriebe

Caractéristiques techniques reducteurs / Datos técnicos reductores / Características técnicas ridutor

	M_{n2}	i	
252	200 Nm	7.81 ÷ 78.17	58
253	200 Nm	79.92 ÷ 332.63	60
302	350 Nm	7.16 ÷ 83.81	62
303	350 Nm	89.95 ÷ 547.27	64
352	600 Nm	5.55 ÷ 68.58	66
353	600 Nm	71.90 ÷ 442.65	68
402	1200 Nm	4.83 ÷ 68.47	70
403	1200 Nm	74.67 ÷ 430.24	72
502	2200 Nm	6.03 ÷ 81.31	74
503	2200 Nm	79.95 ÷ 339.66	76

Dati tecnici riduttori/ Reducer technical data / Technische Daten Getriebe

Caractéristiques techniques reduceurs/ Datos técnicos reductores / Características técnicas ridutor

21

RFV	$n_1 = 2800 \text{ min}^{-1}$			$n_1 = 1400 \text{ min}^{-1}$			$n_1 = 900 \text{ min}^{-1}$			IEC B5	IEC B14	NEMA	
	i	n_2 min ⁻¹	Mn_2 Nm	P_1 kW	n_2 min ⁻¹	Mn_2 Nm	P_1 kW	n_2 min ⁻¹	Mn_2 Nm				P_1 kW
252	7.81	359	84	3.33	179	101	2.00	115	101	1.28	63 71 80 90	71 80 90	56 C 140TC
	9.33	300	91	3.00	150	109	1.80	96	109	1.16			
	10.66	263	95	2.75	131	114	1.65	84	114	1.06			
	12.36	227	99	2.48	113	119	1.49	73	119	0.96			
	14.11	198	109	2.39	99	131	1.43	64	131	0.92			
	16.85	166	117	2.14	83	140	1.28	53	140	0.82			
	19.25	145	122	1.95	73	146	1.17	47	146	0.75			
	20.17	139	126	1.93	69	151	1.16	45	151	0.74			
	23.04	122	130	1.74	61	156	1.04	39	156	0.67			
	25.63	109	139	1.68	55	167	1.01	35	167	0.65			
	30.61	91	153	1.54	46	176	0.89	29	176	0.57			
	34.96	80	166	1.47	40	183	0.81	26	183	0.52			
	40.56	69	181	1.38	35	190	0.72	22	190	0.46			
	45.12	62	200	1.37	31	200	0.68	20	200	0.44			
	49.39	57	200	1.25	28	200	0.62	18	200	0.40			
	53.89	52	200	1.15	26	200	0.57	17	200	0.37			
	61.56	45	200	1.00	23	200	0.50	15	200	0.32			
	71.42	39	200	0.86	20	200	0.43	13	200	0.28			
78.17	36	200	0.79	18	200	0.39	12	200	0.25				



RFV 252 H...IEC

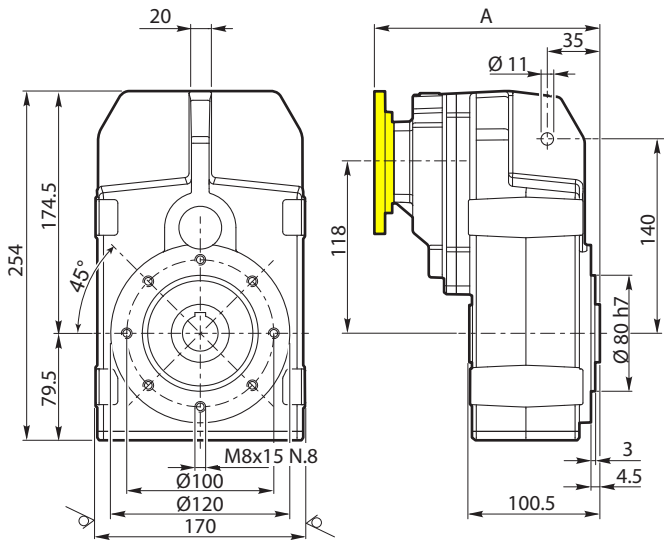

	A	Kg
IEC 63 - 71 - 80 - 90	172	10.5
NEMA 56C - 140TC	180	10.5

RFV 252 H...FV

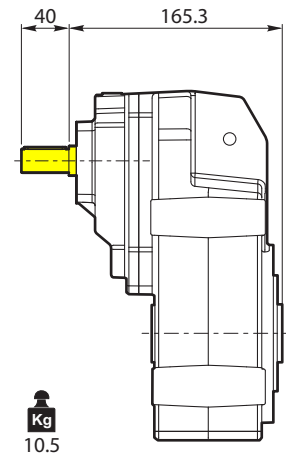

Albero uscita / Output shaft / Abtriebswelle

Arbre de sortie / Eje de salida / Eixo de saída

Albero entrata / Input shaft / Antriebswelle

Arbre d'entrée / Eje de entrada / Eixo de entrada

H25 STANDARD

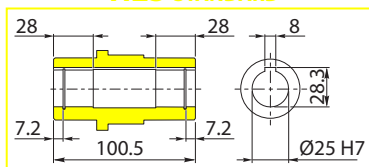

H30

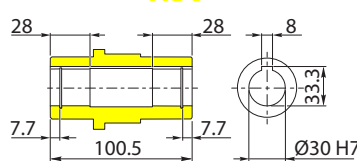

H 1"

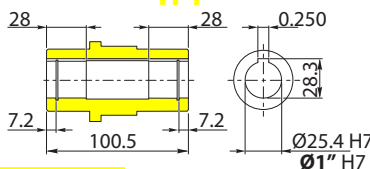

H24

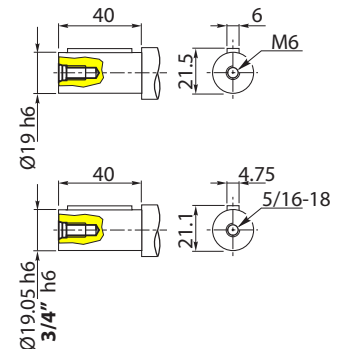
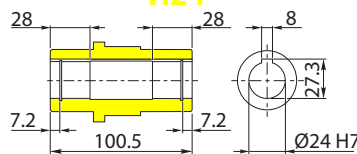



RFV 252 S...

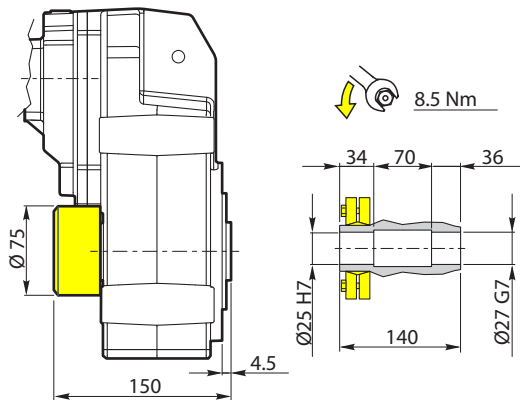

RFV 252 R...

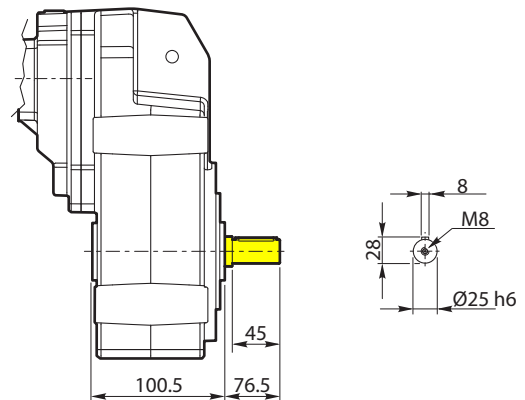

Opzione FL / Option FL / Option FL
 Option FL / Opción FL / Opção FL

RFV 252 ... FL

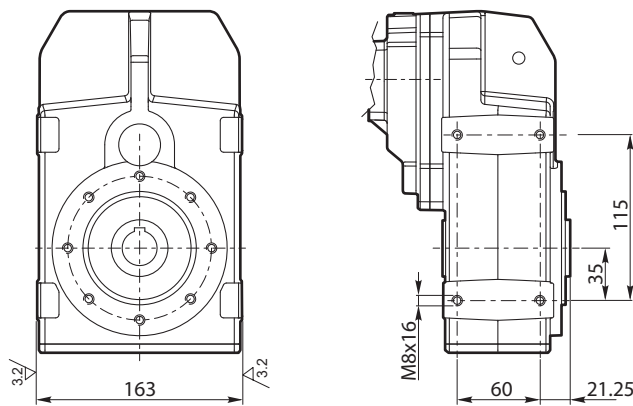

Flange uscita / Output flange / Abtriebsflansch
 Bride de sortie / Brida de salida / Flange de saída

RFV 252 ... F...

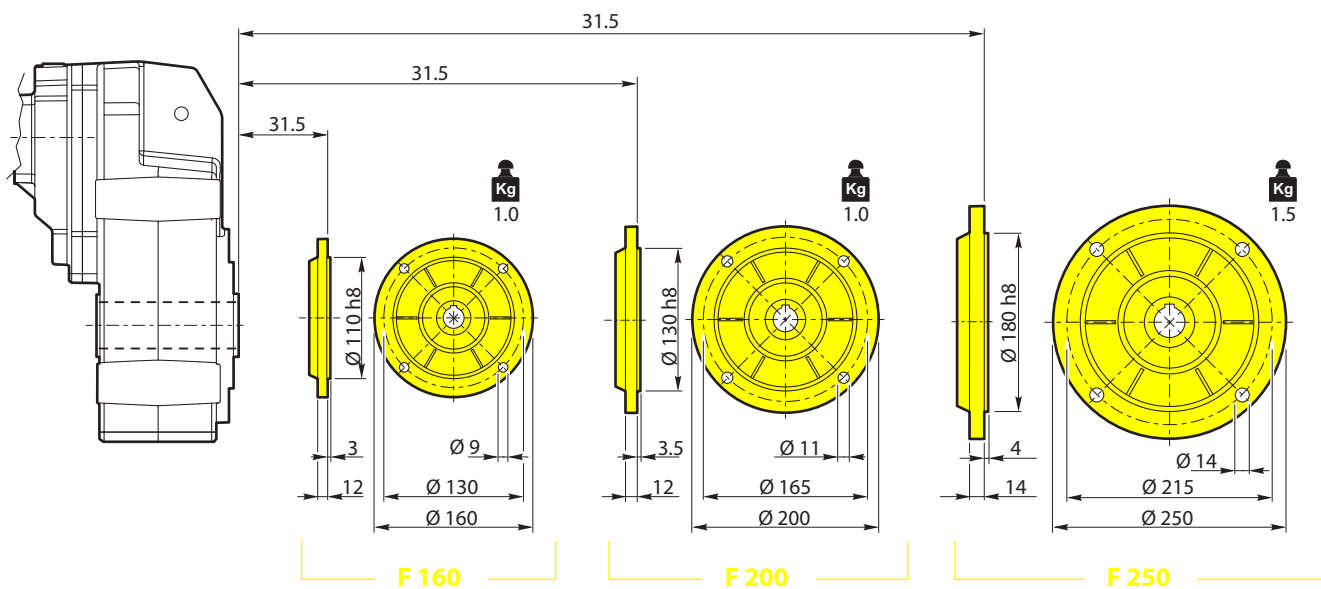

Dati tecnici riduttori/ Reducer technical data / Technische Daten Getriebe

Caractéristiques techniques reducteurs/ Datos técnicos reductores / Características técnicas ridutor

21

RFV	i	$n_1 = 2800 \text{ min}^{-1}$			$n_1 = 1400 \text{ min}^{-1}$			$n_1 = 900 \text{ min}^{-1}$			IEC B5	IEC B14	NEMA
		n_2 min ⁻¹	Mn_2 Nm	P_1 kW	n_2 min ⁻¹	Mn_2 Nm	P_1 kW	n_2 min ⁻¹	Mn_2 Nm	P_1 kW			
253	79.92	35	200	0.79	18	200	0.39	11	200	0.25	56 63 71	56 63 71	56 C
	92.72	30	200	0.68	15	200	0.34	9.7	200	0.22			
	98.47	28	200	0.64	14	200	0.32	9.1	200	0.21			
	117.60	24	200	0.54	12	200	0.27	7.7	200	0.17			
	134.34	21	200	0.47	10	200	0.23	6.7	200	0.15			
	155.85	18	200	0.40	9.0	200	0.20	5.8	200	0.13			
	170.87	16	200	0.37	8.2	200	0.18	5.3	200	0.12			
	204.06	14	200	0.31	6.9	200	0.15	4.4	200	0.10			
	233.10	12	200	0.27	6.0	200	0.14	3.9	200	0.09			
	250.99	11	200	0.25	5.6	200	0.13	3.6	200	0.08			
	270.43	10	200	0.23	5.2	200	0.12	3.3	200	0.07			
	286.71	9.8	200	0.22	4.9	200	0.11	3.1	200	0.07			
	332.63	8.4	200	0.19	4.2	200	0.09	2.7	200	0.06			



RFV 253 H...IEC

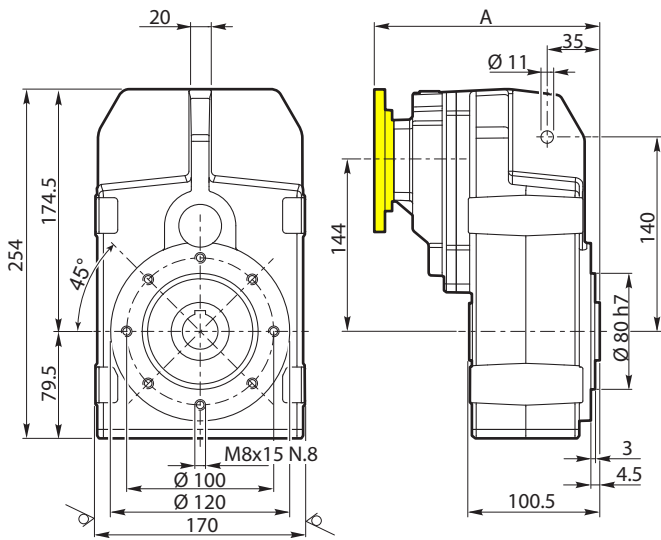

	A	Kg
IEC 56 - 63 - 71	165.5	10
NEMA 56C	187	10

RFV 253 H...FV

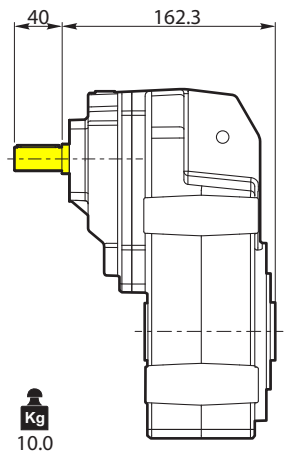

Albero uscita / Output shaft / Abtriebswelle

Arbre de sortie / Eje de salida / Eixo de saída

Albero entrata / Input shaft / Antriebswelle

Arbre d'entrée / Eje de entrada / Eixo de entrada

H25 STANDARD

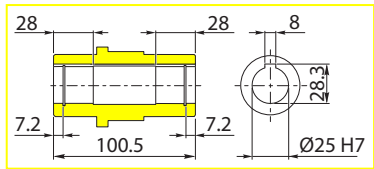

H30

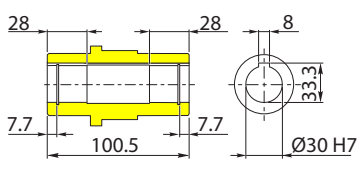

H 1"

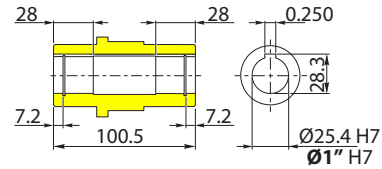

H24

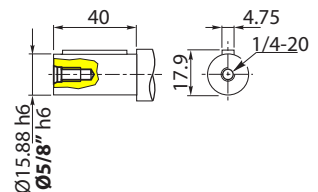
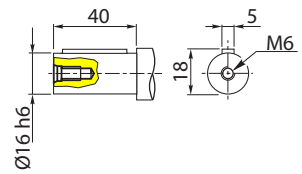
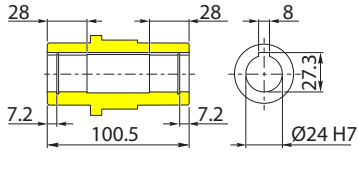



RFV 253 S...

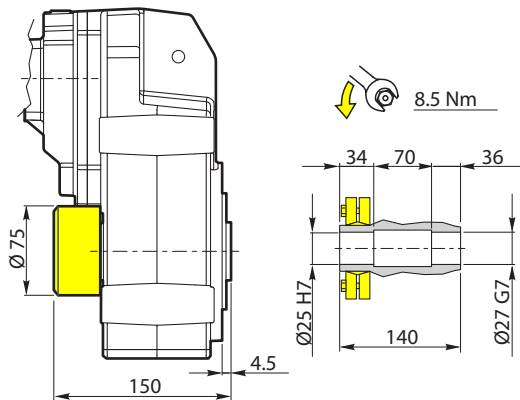

RFV 253 R...

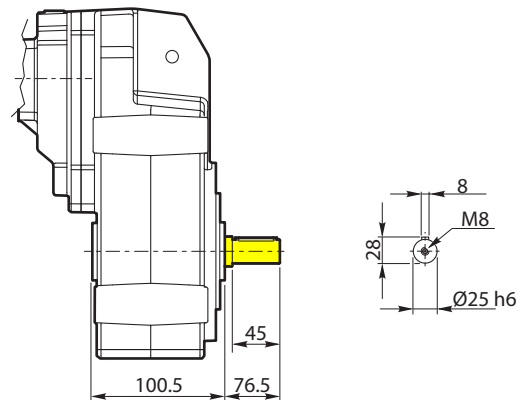

Opzione FL / Option FL / Option FL
 Option FL / Opción FL / Opção FL

RFV 253 ... FL

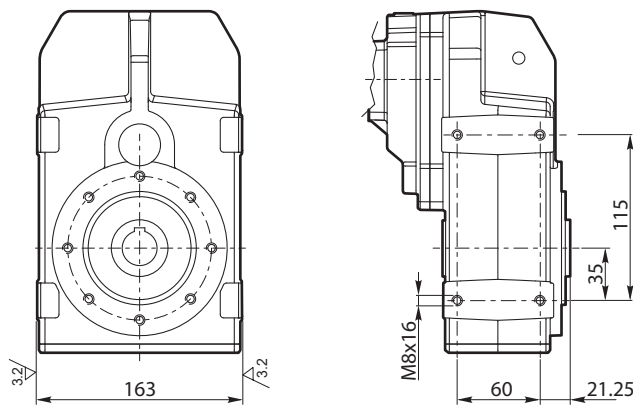

Flange uscita / Output flange / Abtriebsflansch
 Bride de sortie / Brida de salida / Flange de saída

RFV 253 ... F...

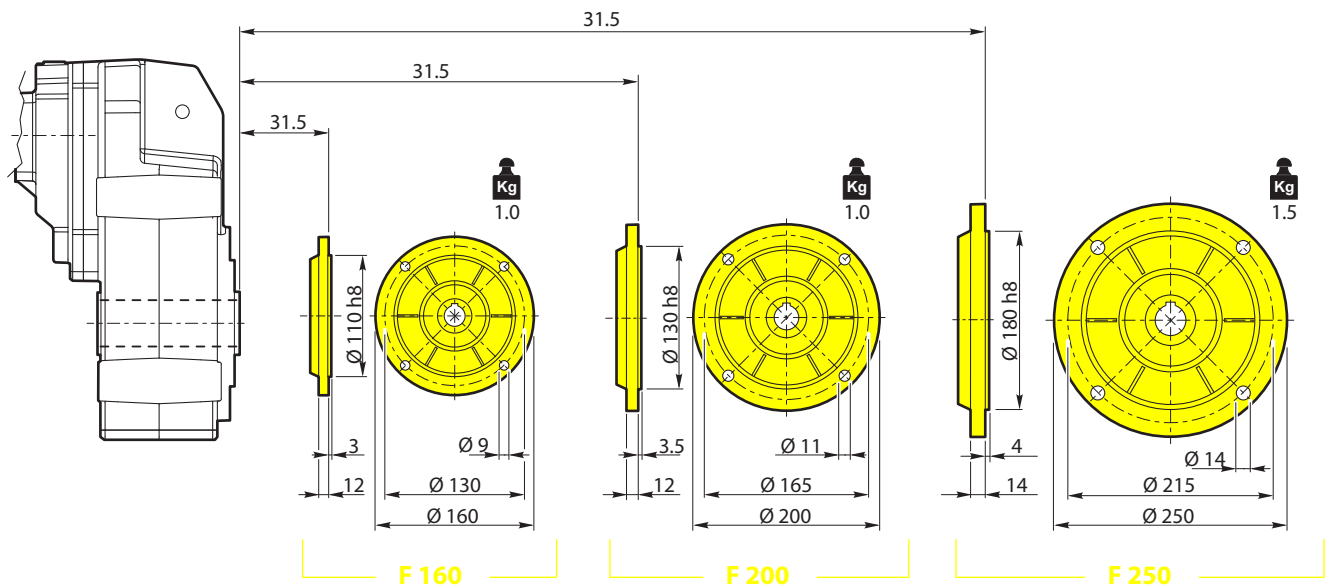

Dati tecnici riduttori/ Reducer technical data / Technische Daten Getriebe

Caractéristiques techniques reduceurs/ Datos técnicos reductores / Características técnicas ridutor

21

RFV	$n_1 = 2800 \text{ min}^{-1}$			$n_1 = 1400 \text{ min}^{-1}$			$n_1 = 900 \text{ min}^{-1}$			IEC B5	IEC B14	NEMA	
	i	n_2 min ⁻¹	Mn_2 Nm	P_1 kW	n_2 min ⁻¹	Mn_2 Nm	P_1 kW	n_2 min ⁻¹	Mn_2 Nm				P_1 kW
302	7.16	391	167	7.18	196	200	4.31	126	200	2.77	63 71 80 90 100 112	71 80 90 100 112	56 C 140 TC
	8.09	346	192	7.31	173	230	4.39	111	230	2.82			
	9.26	302	213	7.08	151	255	4.25	97	255	2.73			
	10.76	260	228	6.55	130	274	3.93	84	274	2.53			
	12.73	220	242	5.86	110	290	3.52	71	290	2.26			
	14.39	195	250	5.36	97	300	3.22	63	300	2.07			
	16.47	170	263	4.92	85	315	2.95	55	315	1.90			
	17.60	159	267	4.68	80	320	2.81	51	320	1.80			
	19.14	146	270	4.35	73	324	2.61	47	324	1.68			
	20.14	139	275	4.21	70	330	2.53	45	330	1.63			
	23.40	120	283	3.74	60	340	2.24	38	340	1.44			
	26.46	106	292	3.40	53	350	2.04	34	350	1.31			
	30.28	92	304	3.10	46	350	1.78	30	350	1.15			
	34.71	81	318	2.83	40	350	1.56	26	350	1.00			
	40.34	69	333	2.55	35	350	1.34	22	350	0.86			
	44.56	63	350	2.42	31	350	1.21	20	350	0.78			
	50.38	56	350	2.14	28	350	1.07	18	350	0.69			
	57.66	49	350	1.87	24	350	0.94	16	350	0.60			
	63.01	44	350	1.71	22	350	0.86	14	350	0.55			
	67.01	42	350	1.61	21	350	0.81	13	350	0.52			
72.11	39	350	1.50	19	350	0.75	12	350	0.48				
83.81	33	350	1.29	17	350	0.64	11	350	0.41				

RFV 302 H...IEC

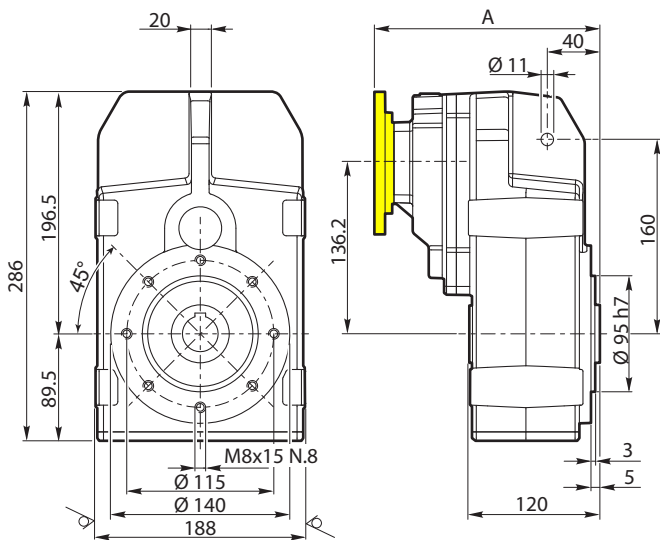

	A	Kg
IEC 63 - 71 - 80 - 90	181.4	15.5
IEC 100 - 112	197.2	15.5
NEMA 56C - 140TC	189	15.5

RFV 302 H...FV

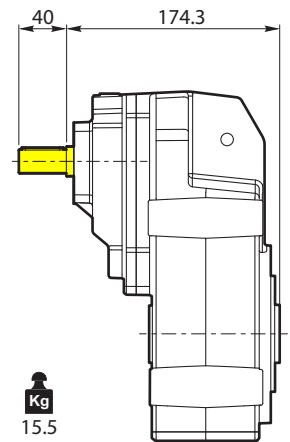

Albero uscita / Output shaft / Abtriebswelle

Arbre de sortie / Eje de salida / Eixo de saída

Albero entrata / Input shaft / Antriebswelle

Arbre d'entrée / Eje de entrada / Eixo de entrada

H30 STANDARD

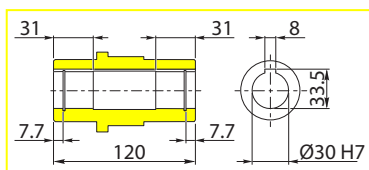

H35

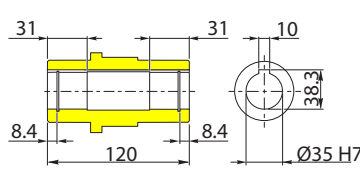

H 1 1/4"

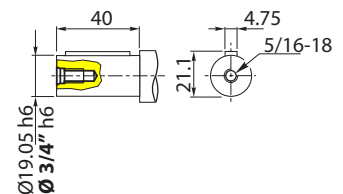
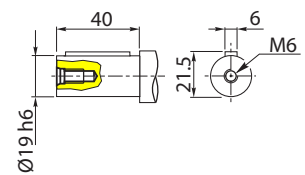
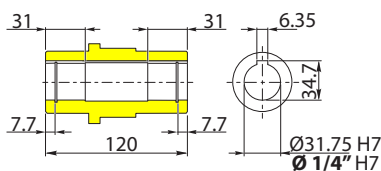



RFV 302 S...

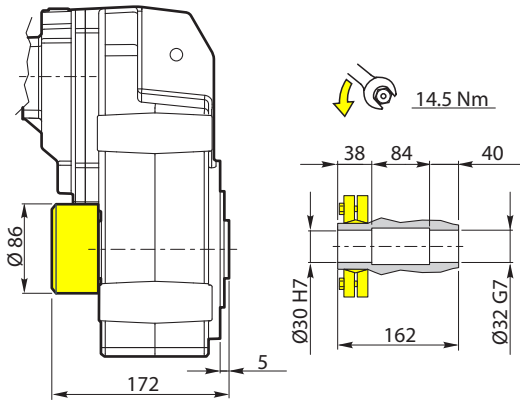

RFV 302 R...

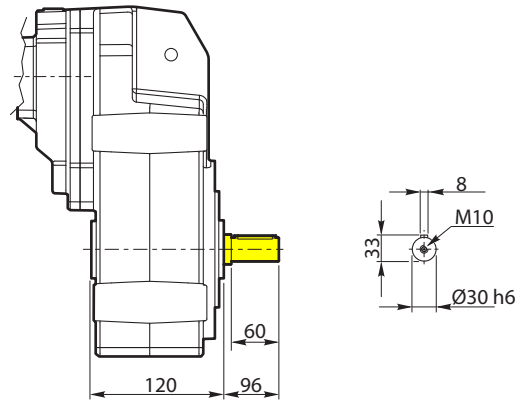

Opzione FL / Option FL / Option FL
 Option FL / Opción FL / Opção FL

RFV 302 ... FL

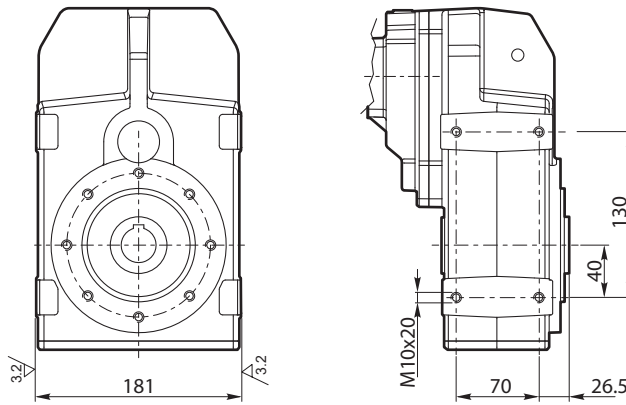

Flange uscita / Output flange / Abtriebsflansch
 Bride de sortie / Brida de salida / Flange de saída

RFV 302 ... F...

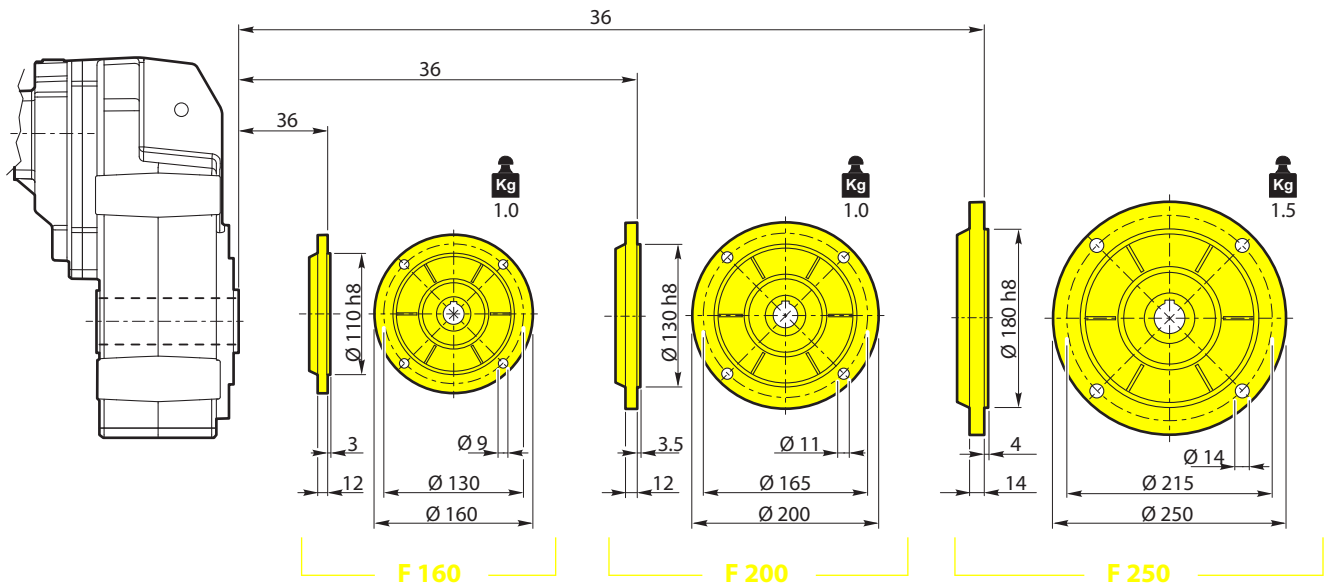

Dati tecnici riduttori/ Reducer technical data / Technische Daten Getriebe

Caractéristiques techniques reducteurs/ Datos técnicos reductores / Características técnicas ridutor

21

RFV	i	$n_1 = 2800 \text{ min}^{-1}$			$n_1 = 1400 \text{ min}^{-1}$			$n_1 = 900 \text{ min}^{-1}$			IEC B5	IEC B14	NEMA
		n_2 min ⁻¹	Mn_2 Nm	P_1 kW	n_2 min ⁻¹	Mn_2 Nm	P_1 kW	n_2 min ⁻¹	Mn_2 Nm	P_1 kW			
303	89.95	31	350	1.23	16	350	0.61	10	350	0.39	56 63 71	56 63 71	56 C
	102.94	27	350	1.07	14	350	0.54	8.7	350	0.34			
	119.64	23	350	0.92	12	350	0.46	7.5	350	0.30			
	128.01	22	350	0.86	11	350	0.43	7.0	350	0.28			
	144.73	19	350	0.76	9.7	350	0.38	6.2	350	0.25			
	165.63	17	350	0.67	8.5	350	0.33	5.4	350	0.21			
	192.50	15	350	0.57	7.3	350	0.29	4.7	350	0.18			
	243.79	11	350	0.45	5.7	350	0.23	3.7	350	0.15			
	275.63	10	350	0.40	5.1	350	0.20	3.3	350	0.13			
	315.43	8.9	350	0.35	4.4	350	0.18	2.9	350	0.11			
	332.51	8.4	350	0.33	4.2	350	0.17	2.7	350	0.11			
	375.94	7.4	350	0.29	3.7	350	0.15	2.4	350	0.09			
	430.23	6.5	350	0.26	3.3	350	0.13	2.1	350	0.08			
	470.88	5.9	350	0.23	3.0	350	0.12	1.9	350	0.08			
	500.02	5.6	350	0.22	2.8	350	0.11	1.8	350	0.07			
	547.27	5.1	350	0.20	2.6	350	0.10	1.6	350	0.06			



RFV 303 H...IEC

RFV 303 H...FV

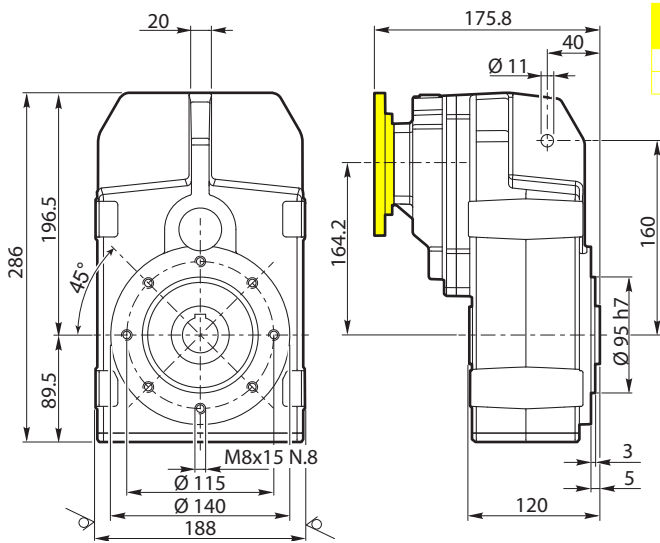

	A	Kg
IEC 56 - 63 - 71	175.8	15
NEMA 56C	197	15

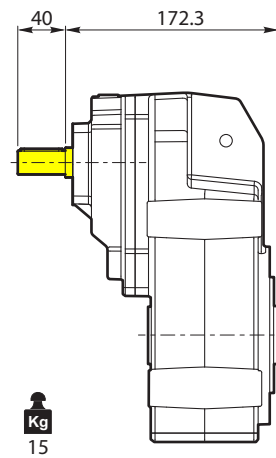

Albero uscita / Output shaft / Abtriebswelle

Arbre de sortie / Eje de salida / Eixo de saída

Albero entrata / Input shaft / Antriebswelle

Arbre d'entrée / Eje de entrada / Eixo de entrada

H30 STANDARD

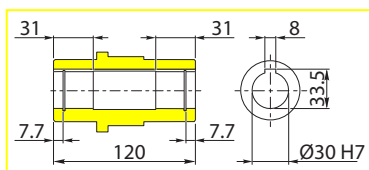

H35

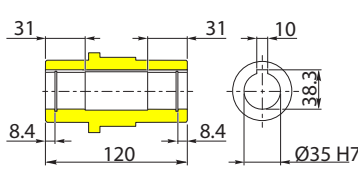

H 1 1/4"

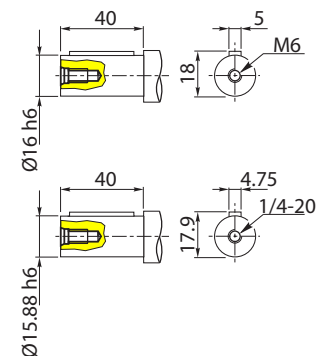
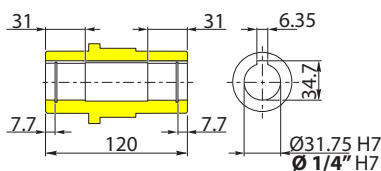



RFV 303 S...

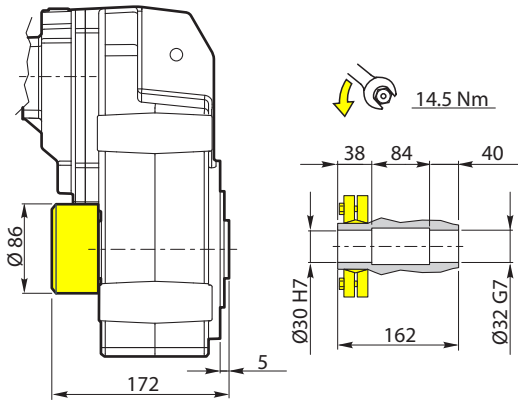

RFV 303 R...

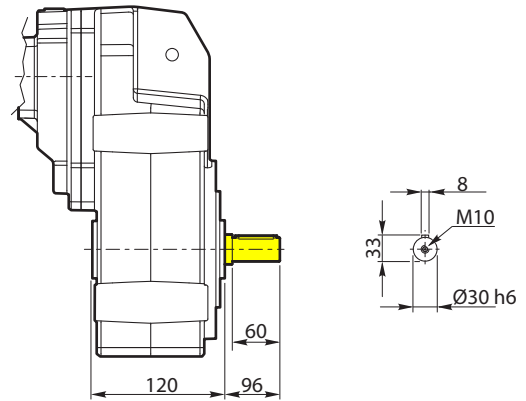

Opzione FL / Option FL / Option FL
 Option FL / Opción FL / Opção FL

RFV 303 ... FL

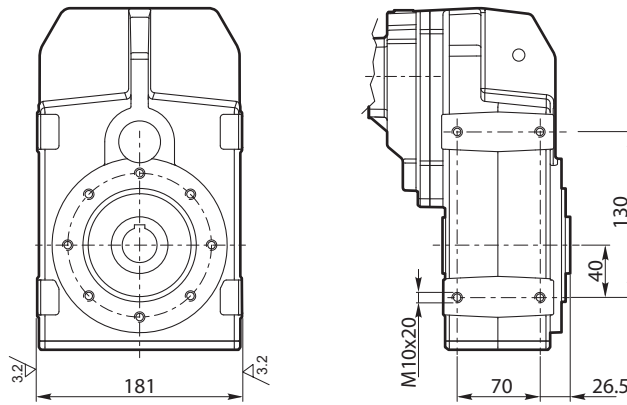

Flange uscita / Output flange / Abtriebsflansch
 Bride de sortie / Brida de salida / Flange de saída

RFV 303 ... F...

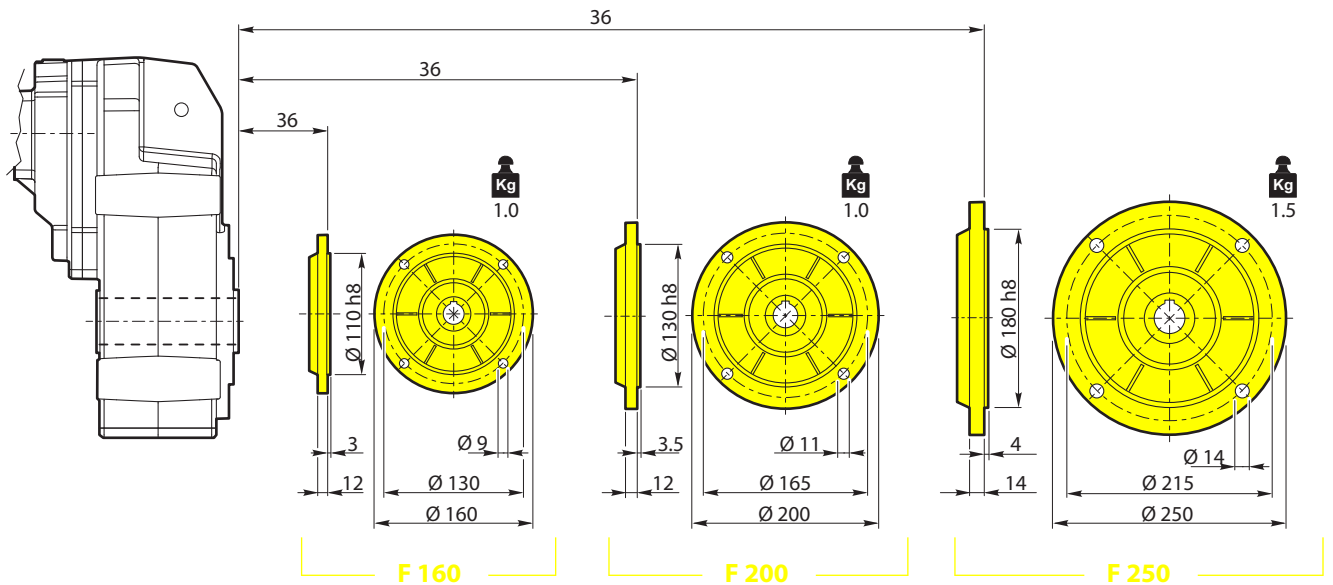

Dati tecnici riduttori/ Reducer technical data / Technische Daten Getriebe

Caractéristiques techniques reducteurs/ Datos técnicos reductores / Características técnicas ridutor

21

RFV	$n_1 = 2800 \text{ min}^{-1}$			$n_1 = 1400 \text{ min}^{-1}$			$n_1 = 900 \text{ min}^{-1}$			IEC B5	IEC B14	NEMA	
	i	n_2 min ⁻¹	Mn_2 Nm	P_1 kW	n_2 min ⁻¹	Mn_2 Nm	P_1 kW	n_2 min ⁻¹	Mn_2 Nm				P_1 kW
352	5.55	505	243	13.53	252	292	8.12	162	292	5.22	71 80 90 100 112 132	71 80 90 100 112 132	56 C 140 TC 180 TC
	6.45	434	268	12.84	217	322	7.70	140	322	4.95			
	7.63	367	305	12.34	183	366	7.40	118	366	4.76			
	9.23	303	349	11.68	152	419	7.01	98	419	4.50			
	12.83	218	382	9.18	109	458	5.51	70	458	3.54			
	14.91	188	427	8.84	94	513	5.31	60	513	3.41			
	16.95	165	431	7.85	83	517	4.71	53	517	3.03			
	19.69	142	479	7.51	71	575	4.51	46	575	2.90			
	21.58	130	482	6.90	65	574	4.10	42	574	2.64			
	23.29	120	500	6.63	60	600	3.98	39	600	2.56			
	25.07	112	500	6.16	56	600	3.69	36	600	2.37			
	29.64	94	500	5.21	47	600	3.12	30	600	2.01			
	33.38	84	500	4.62	42	600	2.77	27	600	1.78			
	35.88	78	500	4.30	39	600	2.58	25	600	1.66			
	39.47	71	500	3.91	35	600	2.35	23	600	1.51			
	41.24	68	500	3.74	34	600	2.25	22	600	1.44			
	47.93	58	522	3.36	29	600	1.93	19	600	1.24			
	56.66	49	545	2.97	25	600	1.63	16	600	1.05			
	68.58	41	571	2.57	20	600	1.35	13	600	0.87			
											63 71 80 90 100 112	71 80 90 100 112	56 C 140 TC

RFV 352 H...IEC

RFV 352 H...FV

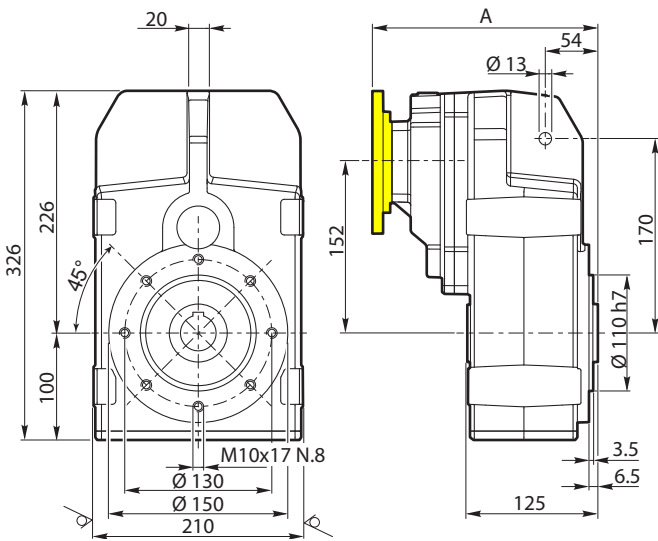

A	Kg
50 (Ø24-Ø25.4)	31
40 (Ø19-Ø19.05)	31
IEC 63-71-80-90	217
IEC 100-112	234.5
IEC 132	265
NEMA 56C - 140TC	225
NEMA 180TC	272

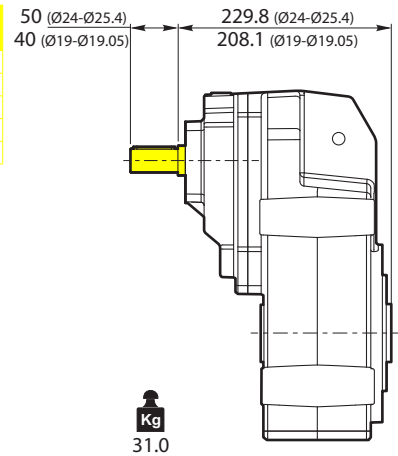

Albero uscita / Output shaft / Abtriebswelle

Arbre de sortie / Eje de salida / Eixo de saída

Albero entrata / Input shaft / Antriebswelle

Arbre d'entrée / Eje de entrada / Eixo de entrada

H35 STANDARD

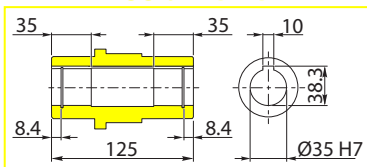

H40

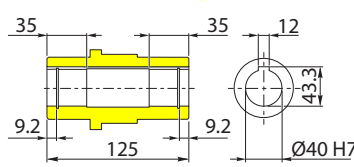

H 1 3/8"

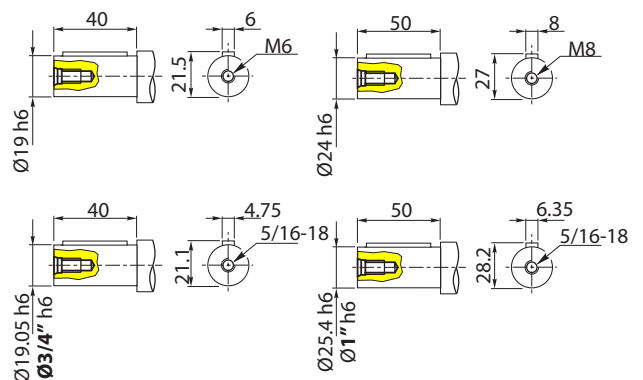
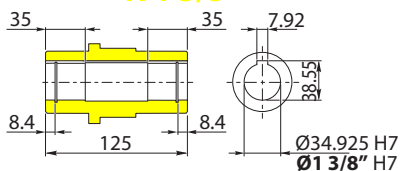



RFV 352 S...

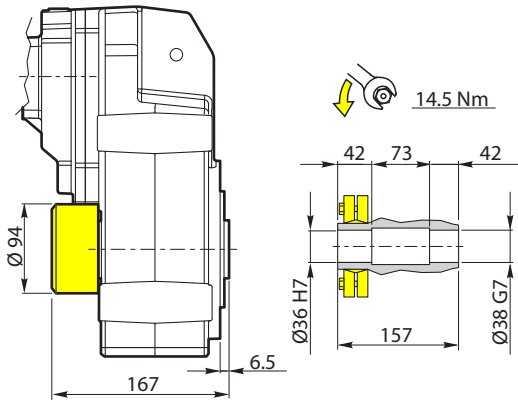

RFV 352 R...

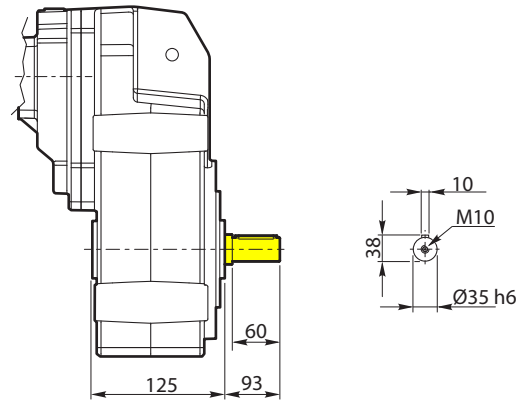

Opzione FL / Option FL / Option FL
 Option FL / Opción FL / Opção FL

RFV 352 ... FL

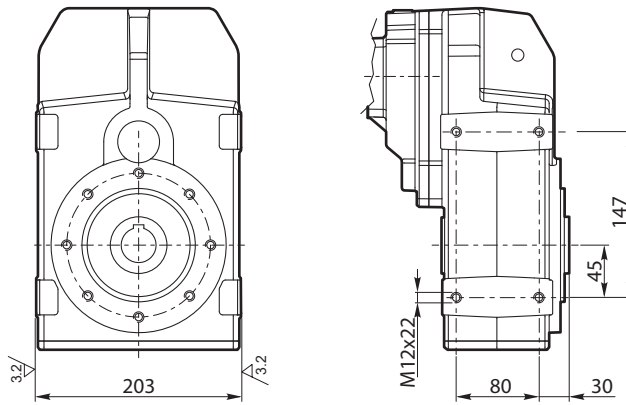

Flange uscita / Output flange / Abtriebsflansch
 Bride de sortie / Brida de salida / Flange de saída

RFV 352 ... F...

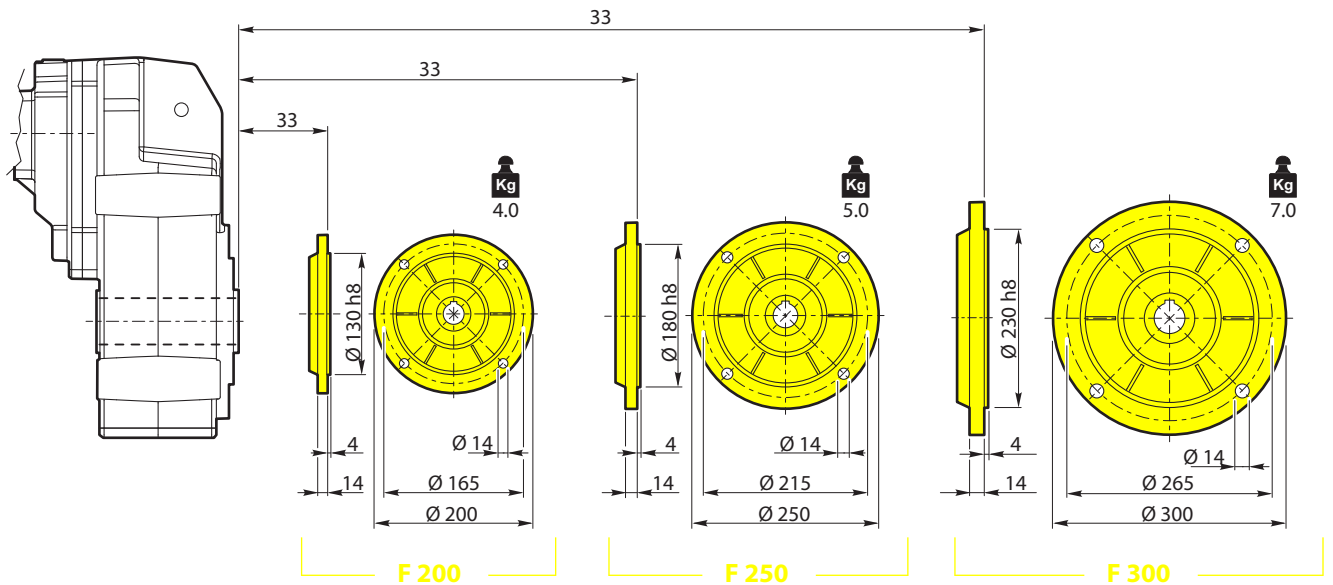

Dati tecnici riduttori/ Reducer technical data / Technische Daten Getriebe

Caractéristiques techniques reducteurs/ Datos técnicos reductores / Características técnicas ridutor

21

RFV	i	$n_1 = 2800 \text{ min}^{-1}$			$n_1 = 1400 \text{ min}^{-1}$			$n_1 = 900 \text{ min}^{-1}$			IEC B5	IEC B14	NEMA
		n_2 min ⁻¹	Mn_2 Nm	P_1 kW	n_2 min ⁻¹	Mn_2 Nm	P_1 kW	n_2 min ⁻¹	Mn_2 Nm	P_1 kW			
353	71.90	39	600	2.63	19	600	1.32	13	600	0.85	63 71 80 90	71 80 90	56 C 140 TC
	85.01	33	600	2.23	16	600	1.11	11	600	0.72			
	95.25	29	600	1.99	15	600	0.99	9.4	600	0.64			
	102.89	27	600	1.84	14	600	0.92	8.7	600	0.59			
	110.69	25	600	1.71	13	600	0.85	8.1	600	0.55			
	122.04	23	600	1.55	11	600	0.78	7.4	600	0.50			
	130.87	21	600	1.45	11	600	0.72	6.9	600	0.46			
	147.71	19	600	1.28	9.5	600	0.64	6.1	600	0.41			
	158.39	18	600	1.19	8.8	600	0.60	5.7	600	0.38			
	184.22	15	600	1.03	7.6	600	0.51	4.9	600	0.33			
	214.07	13	600	0.88	6.5	600	0.44	4.2	600	0.28			
	253.10	11	600	0.75	5.5	600	0.37	3.6	600	0.24			
	306.32	9.1	600	0.62	4.6	600	0.31	2.9	600	0.20			
	365.74	7.7	600	0.52	3.8	600	0.26	2.5	600	0.17			
	442.65	6.3	600	0.43	3.2	600	0.21	2.0	600	0.14			

RFV 353 H...IEC

RFV 353 H...FV

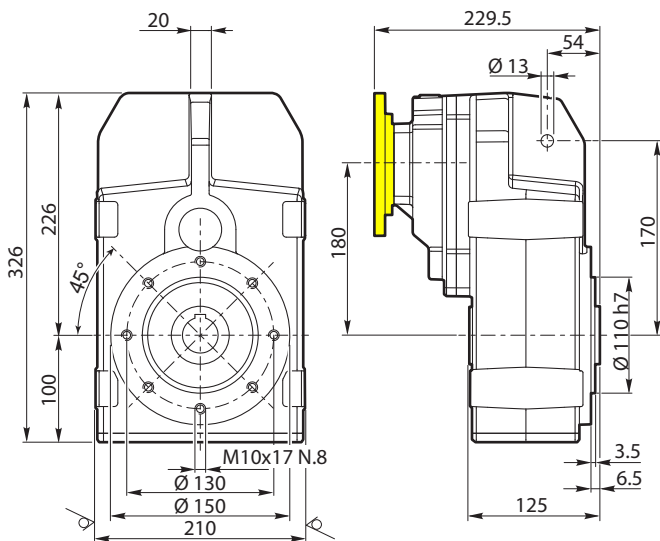

	A	Kg
IEC 63-71-80-90	229.5	31
NEMA 56C-140TC	237.5	32

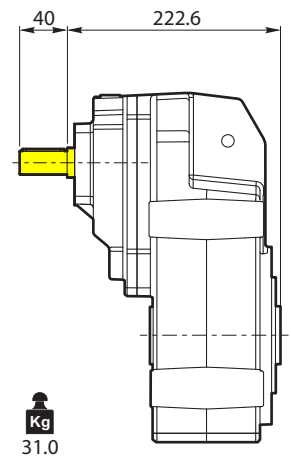

Albero uscita / Output shaft / Abtriebswelle

Arbre de sortie / Eje de salida / Eixo de saída

Albero entrata / Input shaft / Antriebswelle

Arbre d'entrée / Eje de entrada / Eixo de entrada

H35 STANDARD

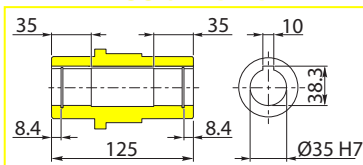

H40

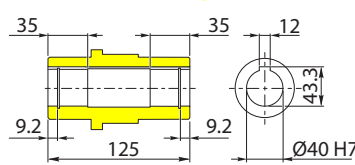

H 1 3/8"

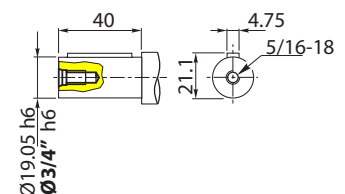
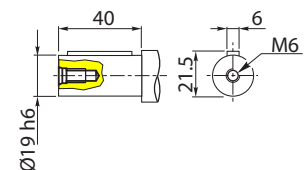
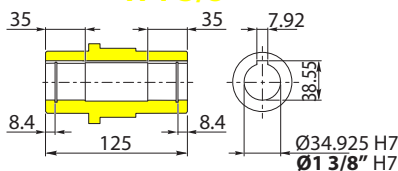



RFV 353 S...

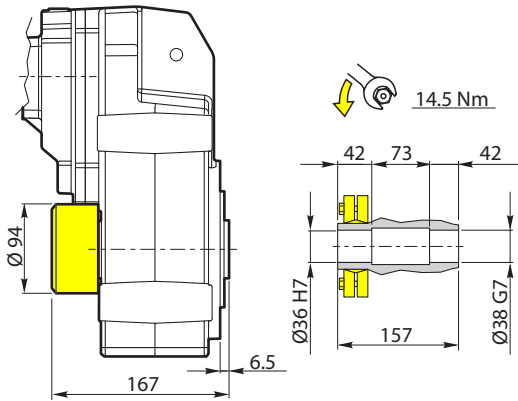

RFV 353 R...

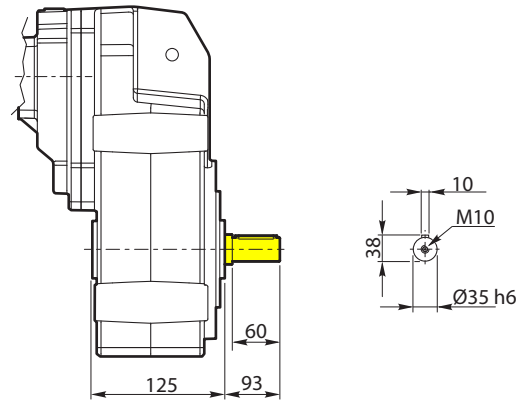

Opzione FL / Option FL / Option FL
 Option FL / Opción FL / Opção FL

RFV 353 ... FL

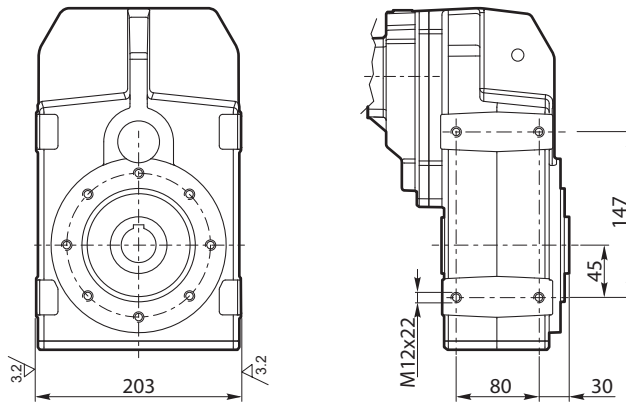

Flange uscita / Output flange / Abtriebsflansch
 Bride de sortie / Brida de salida / Flange de saída

RFV 353 ... F...

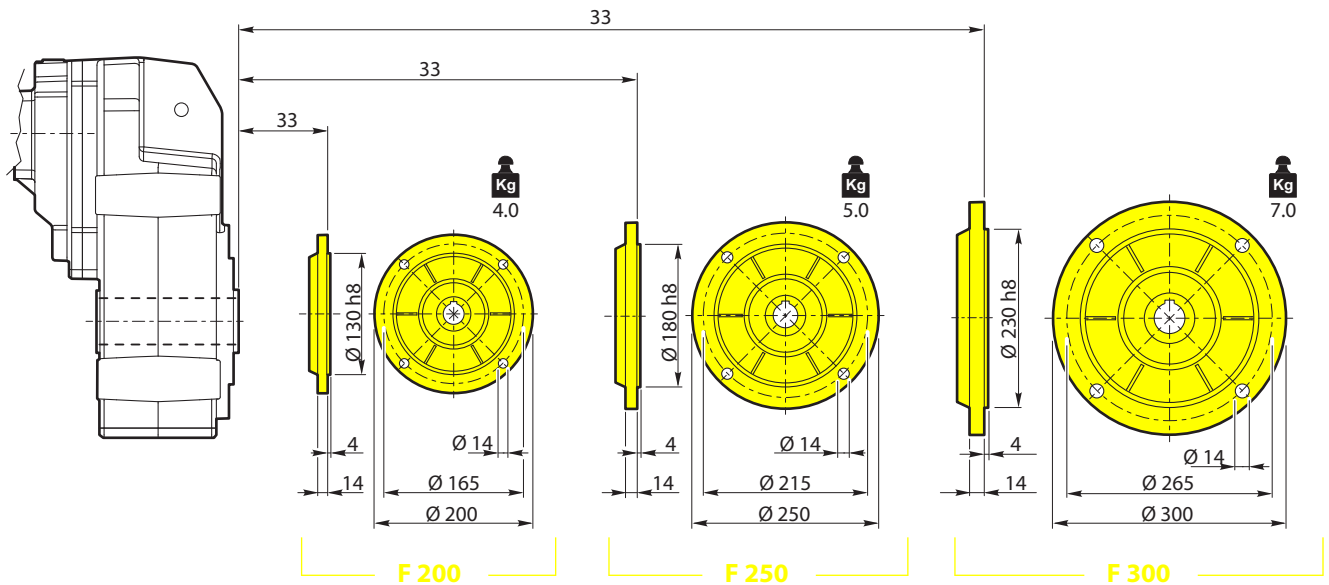

Dati tecnici riduttori/ Reducer technical data / Technische Daten Getriebe

Caractéristiques techniques reducteurs/ Datos técnicos reductores / Características técnicas ridutor

21

RFV	$n_1 = 2800 \text{ min}^{-1}$			$n_1 = 1400 \text{ min}^{-1}$			$n_1 = 900 \text{ min}^{-1}$			IEC B5	IEC B14	NEMA	
	i	n_2 min ⁻¹	Mn_2 Nm	P_1 kW	n_2 min ⁻¹	Mn_2 Nm	P_1 kW	n_2 min ⁻¹	Mn_2 Nm				P_1 kW
402	4.83	580	380	24.27	290	454	14.51	186	454	9.33	71 80 90 100 112 132	90 100 112 132	140 TC 180 TC 210 TC
	5.58	502	423	23.38	251	507	14.01	161	507	9.01			
	6.60	424	475	22.17	212	570	13.31	136	570	8.56			
	7.63	367	516	20.86	183	619	12.51	118	619	8.04			
	8.96	313	581	20.02	156	697	12.01	100	697	7.72			
	10.72	261	638	18.37	131	765	11.01	84	765	7.08			
	12.17	230	648	16.45	115	781	9.91	74	781	6.37			
	14.06	199	722	15.85	100	866	9.51	64	866	6.11			
	16.50	170	812	15.19	85	974	9.11	55	974	5.85			
	19.75	142	864	13.50	71	1037	8.11	46	1037	5.21			
	22.60	124	867	11.84	62	1040	7.10	40	1040	4.57			
	26.12	107	918	10.85	54	1101	6.50	34	1101	4.18			
	30.64	91	1000	10.07	46	1200	6.04	29	1200	3.89			
	34.52	81	1000	8.94	41	1200	5.37	26	1200	3.45			
	40.50	69	1000	7.62	35	1200	4.57	22	1200	2.94			
	48.48	58	1043	6.64	29	1200	3.82	19	1200	2.46			
	57.20	49	1091	5.89	24	1200	3.24	16	1200	2.08			
68.47	41	1143	5.15	20	1200	2.70	13	1200	1.74				
										71 - 80 - 90 100 - 112	90 100 - 112	140 TC 180 TC 210 TC	

RFV 402 H...IEC

RFV 402 H...FV

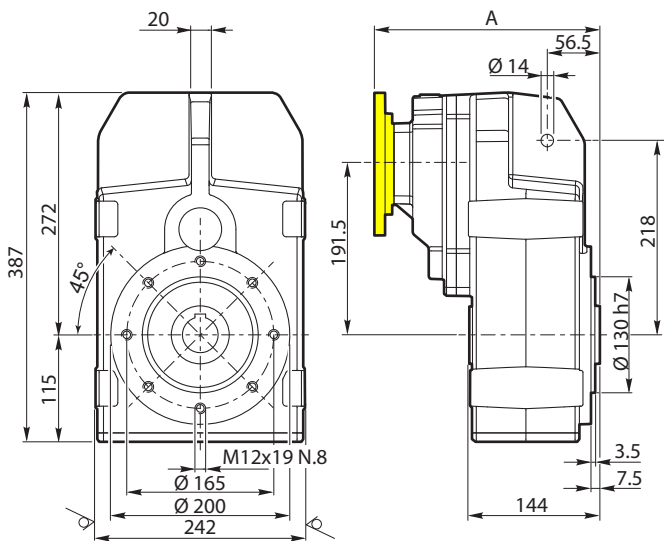

	A	Kg
IEC 71-80-90-100-112	251.3	50
IEC 132	282.5	57
NEMA 140	283.5	47.5
NEMA 180/210	289.5	

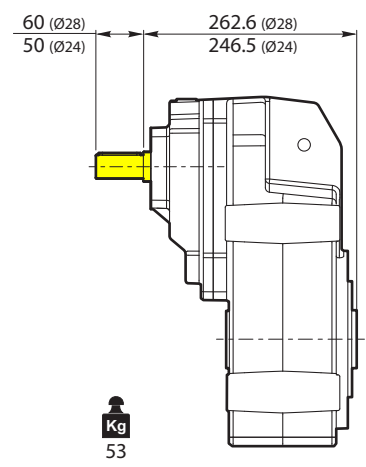

Albero uscita / Output shaft / Abtriebswelle

Albero entrata / Input shaft / Antriebswelle

Arbre de sortie / Eje de salida / Eixo de saída

Arbre d'entrée / Eje de entrada / Eixo de entrada

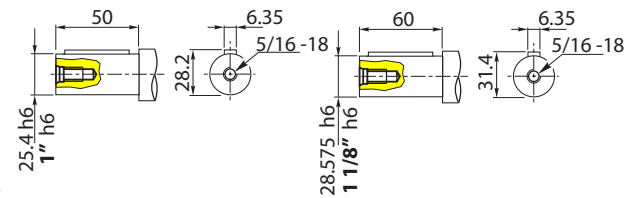
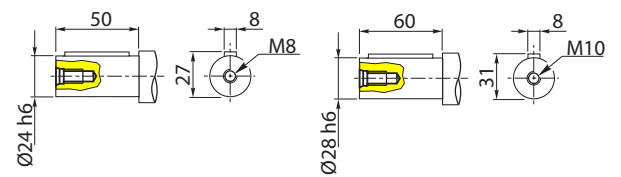
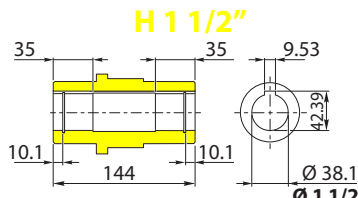
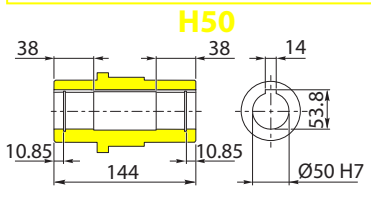
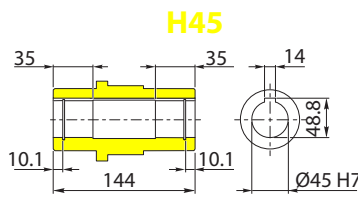
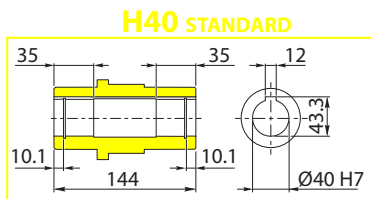



RFV 402 S...

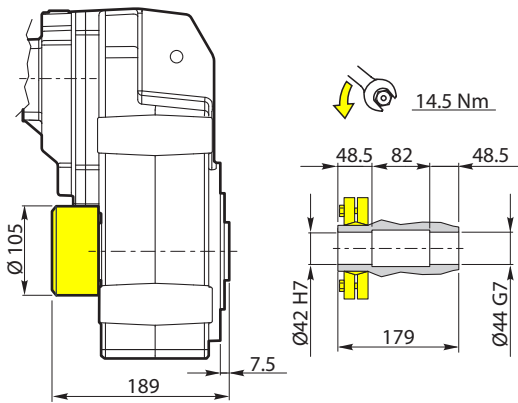

RFV 402 R...

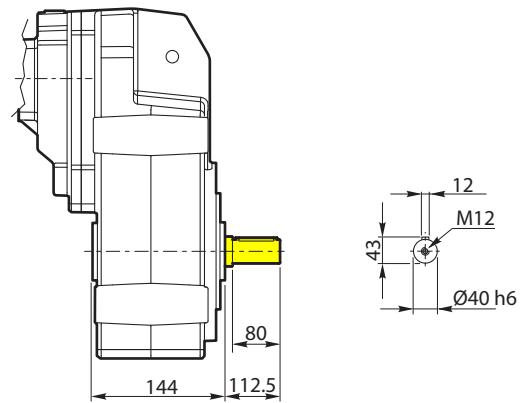

Opzione FL / Option FL / Option FL
 Option FL / Opción FL / Opção FL

RFV 402 ... FL

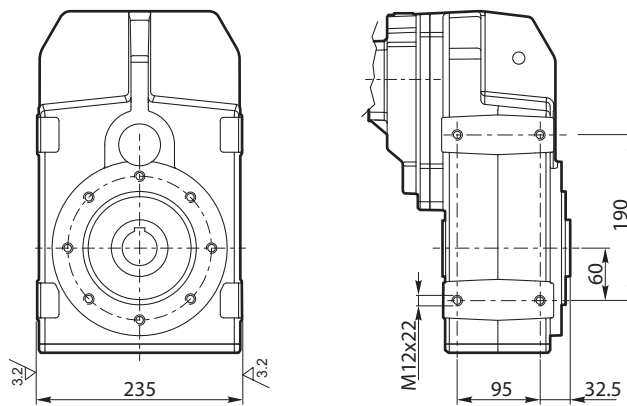

Flange uscita / Output flange / Abtriebsflansch
 Bride de sortie / Brida de salida / Flange de saída

RFV 402 ... F...

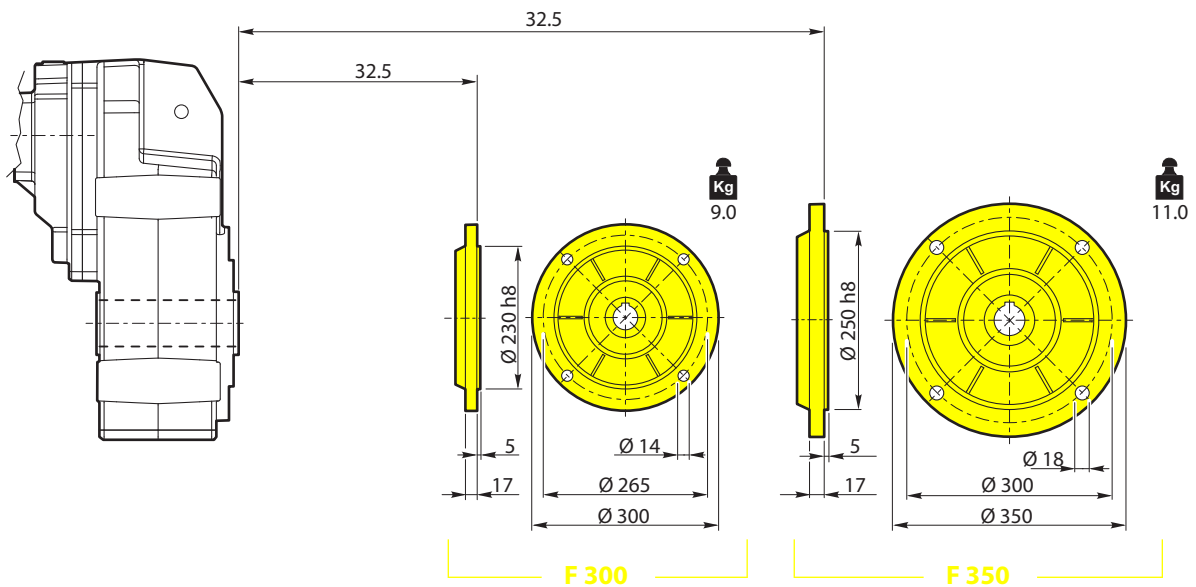

Dati tecnici riduttori/ Reducer technical data / Technische Daten Getriebe

Caractéristiques techniques reducteurs/ Datos técnicos reductores / Características técnicas ridutor

21

RFV	$n_1 = 2800 \text{ min}^{-1}$				$n_1 = 1400 \text{ min}^{-1}$				$n_1 = 900 \text{ min}^{-1}$				 IEC B5 IEC B14 NEMA		
	i	n_2 min ⁻¹	Mn_2 Nm	P_1 kW	n_2 min ⁻¹	Mn_2 Nm	P_1 kW	n_2 min ⁻¹	Mn_2 Nm	P_1 kW					
403	74.67	37	1200	5.07	19	1200	2.53	12	1200	1.63	71 80 90	71 80 90	56 C 140 TC		
	86.31	32	1200	4.38	16	1200	2.19	10	1200	1.41					
	101.27	28	1200	3.74	14	1200	1.87	8.9	1200	1.20					
	108.91	26	1200	3.47	13	1200	1.74	8.3	1200	1.12					
	125.89	22	1200	3.01	11	1200	1.50	7.1	1200	0.97					
	138.65	20	1200	2.73	10	1200	1.36	6.5	1200	0.88					
	147.71	19	1200	2.56	9.5	1200	1.28	6.1	1200	0.82					
	160.26	17	1200	2.36	8.7	1200	1.18	5.6	1200	0.76					
	170.24	16	1200	2.22	8.2	1200	1.11	5.3	1200	0.71					
	188.04	15	1200	2.01	7.4	1200	1.01	4.8	1200	0.65					
	203.77	14	1200	1.86	6.9	1200	0.93	4.4	1200	0.60					
	213.38	13	1200	1.77	6.6	1200	0.89	4.2	1200	0.57					
	250.36	11	1200	1.51	5.6	1200	0.76	3.6	1200	0.49					
	265.04	11	1200	1.43	5.3	1200	0.71	3.4	1200	0.46					
	306.34	9.1	1200	1.24	4.6	1200	0.62	2.9	1200	0.40					
	359.44	7.8	1200	1.05	3.9	1200	0.53	2.5	1200	0.34					
430.24	6.5	1200	0.88	3.3	1200	0.44	2.1	1200	0.28						
											63 71 80 90	71 80 90	56 C 140 TC		

RFV 403 H...IEC

RFV 403 H...FV

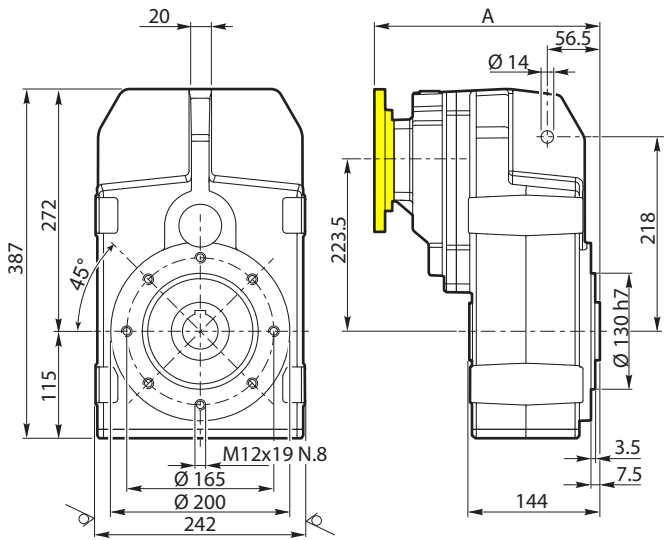

	A	 Kg
IEC 63-71-80-90	252.5	50
NEMA 56C-140TC	260.5	32

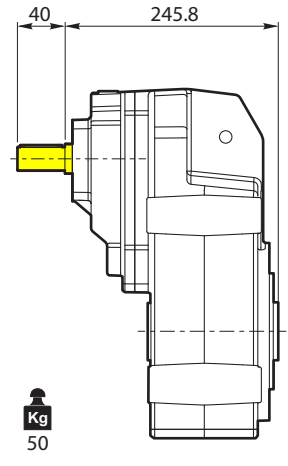

Albero uscita / Output shaft / Abtriebswelle

Albero entrata / Input shaft / Antriebswelle

Arbre de sortie / Eje de salida / Eixo de saída

Arbre d'entrée / Eje de entrada / Eixo de entrada

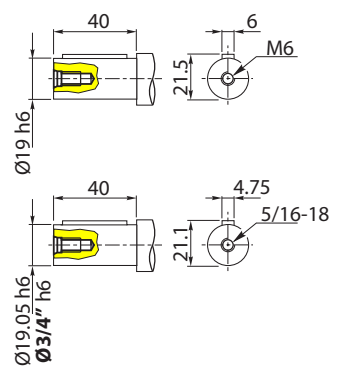
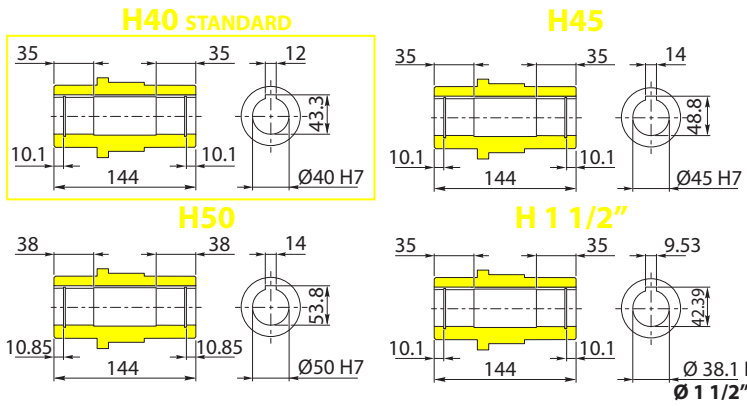



RFV 403 S...

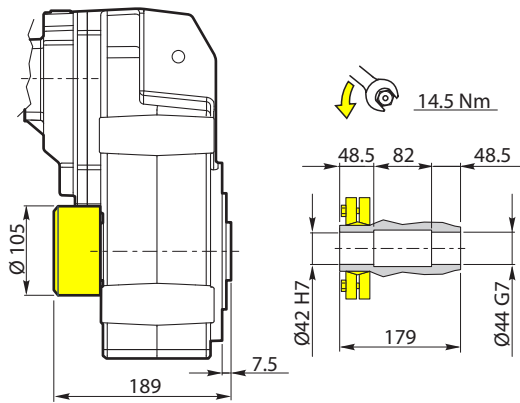

RFV 403 R...

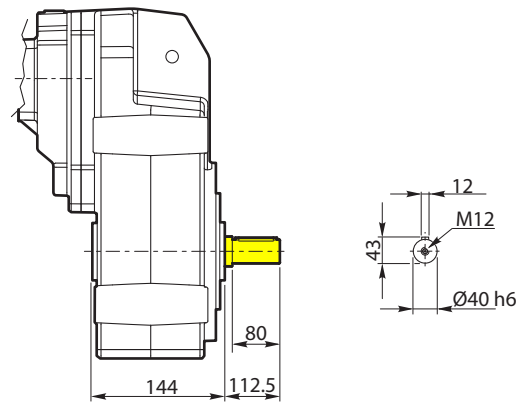

22

Opzione FL / Option FL / Option FL
 Option FL / Opción FL / Opção FL

RFV 403 ... FL

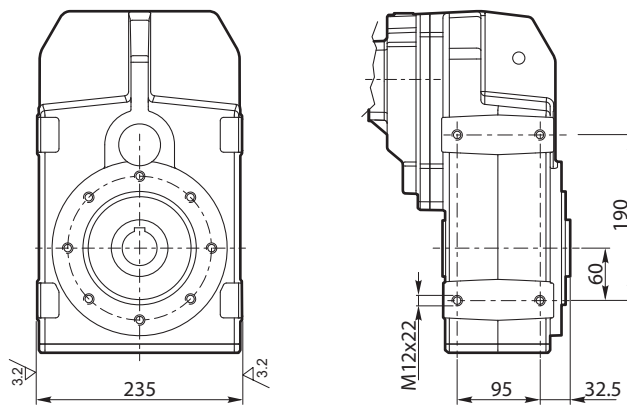

Flange uscita / Output flange / Abtriebsflansch
 Bride de sortie / Brida de salida / Flange de saída

RFV 403 ... F...

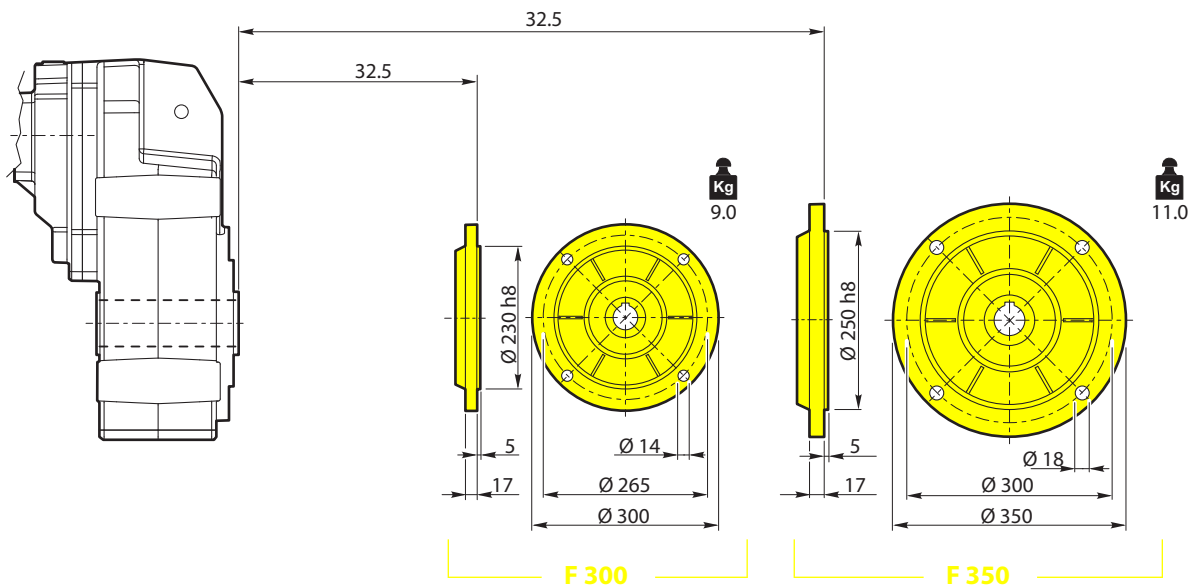

Dati tecnici riduttori/ Reducer technical data / Technische Daten Getriebe

Caractéristiques techniques reducteurs/ Datos técnicos reductores / Características técnicas ridutor

21

RFV	$n_1 = 2800 \text{ min}^{-1}$			$n_1 = 1400 \text{ min}^{-1}$			$n_1 = 900 \text{ min}^{-1}$			IEC B5	IEC B14	NEMA
	i	n_2 min ⁻¹	Mn_2 Nm	P_1 kW	n_2 min ⁻¹	Mn_2 Nm	P_1 kW	n_2 min ⁻¹	Mn_2 Nm			
502	6.03	465	834	42.70	232	1000	25.62	149	1000	16.47	80 90 100 112 132 160 180	140 TC 180 TC 210 TC 250 TC 280 TC
	7.06	397	904	39.53	198	1085	23.72	128	1085	15.25		
	8.24	340	1002	37.53	170	1203	22.52	109	1203	14.47		
	9.66	290	1148	36.69	145	1377	22.02	93	1377	14.15		
	11.54	243	1247	33.36	121	1496	20.01	78	1496	12.87		
	12.73	220	1273	30.85	110	1527	18.51	71	1527	11.90		
	13.55	207	1120	25.52	103	1344	15.31	66	1344	9.84		
	16.19	173	1330	25.35	86	1596	15.21	56	1596	9.78		
	17.87	157	1458	25.18	78	1750	15.11	50	1750	9.71		
	21.25	132	1722	25.02	66	2067	15.01	42	2067	9.65		
	23.45	119	1838	24.18	60	2205	14.51	38	2205	9.33		
	26.43	106	1842	21.51	53	2211	12.91	34	2211	8.30		
	29.12	96	1747	18.51	48	2096	11.11	31	2096	7.14		
	32.14	87	1910	18.35	44	2293	11.01	28	2293	7.08		
	37.14	75	1846	15.34	38	2215	9.21	24	2215	5.92		
	39.46	71	1706	13.34	35	2047	8.01	23	2047	5.15		
	43.56	64	1765	12.51	32	2118	7.51	21	2118	4.82		
	52.16	54	1691	10.01	27	2029	6.00	17	2029	3.86		
	57.57	49	1785	9.57	24	2053	5.50	16	2053	3.54		
	73.67	38	1564	6.55	19	1720	3.60	12	1720	2.32		
81.31	34	1757	6.67	17	1845	3.50	11	1845	2.25			
										80 - 90 100 - 112	140 TC 180 TC 210 TC	

RFV 502 H...IEC

RFV 502 H...FV

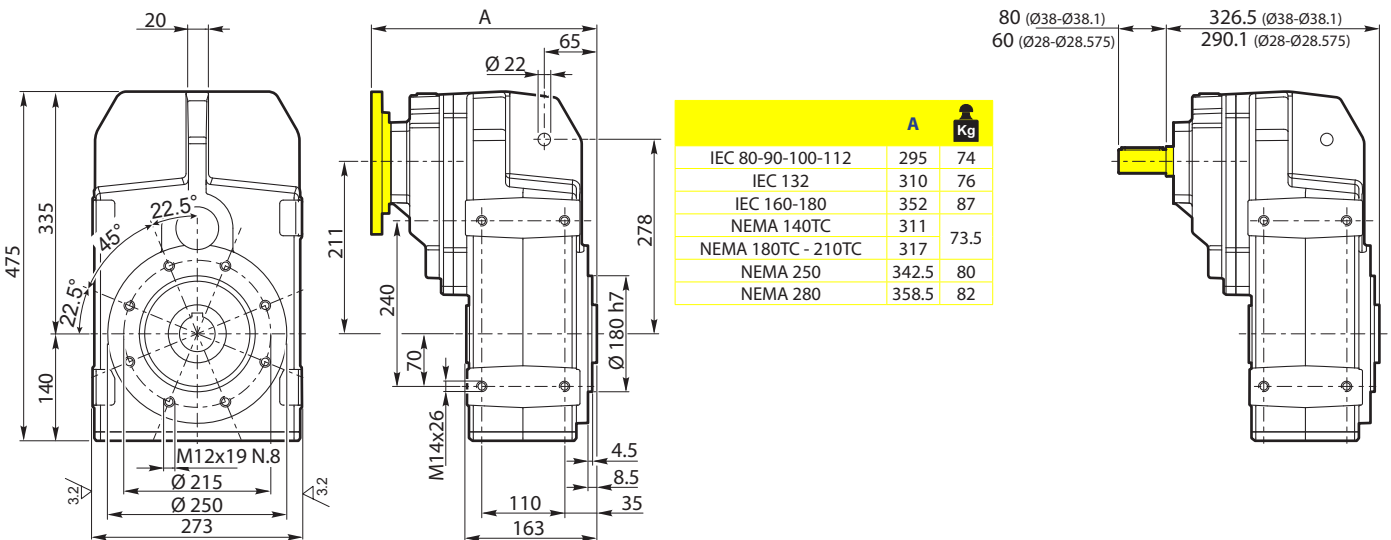

Albero uscita / Output shaft / Abtriebswelle

Albero entrata / Input shaft / Antriebswelle

Arbre de sortie / Eje de salida / Eixo de saída

Arbre d'entrée / Eje de entrada / Eixo de entrada

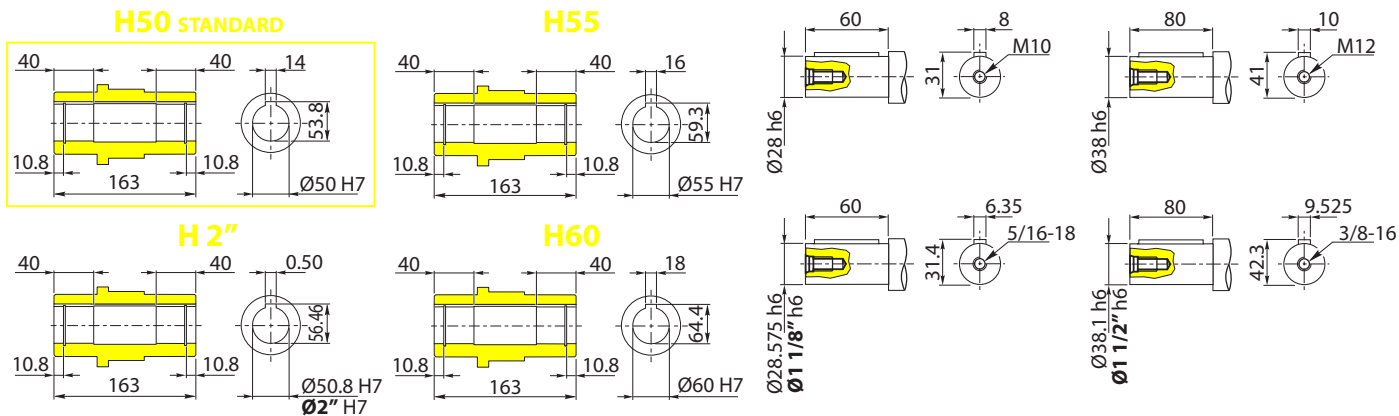



RFV 502 S...

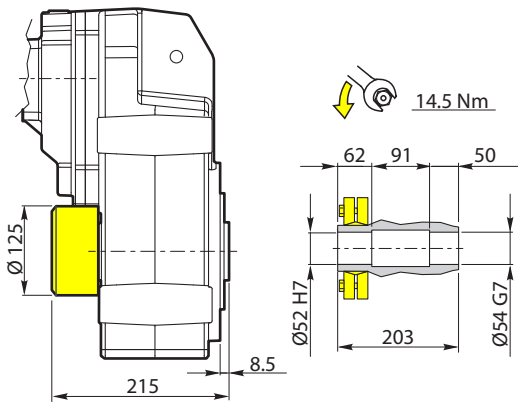

RFV 502 R...

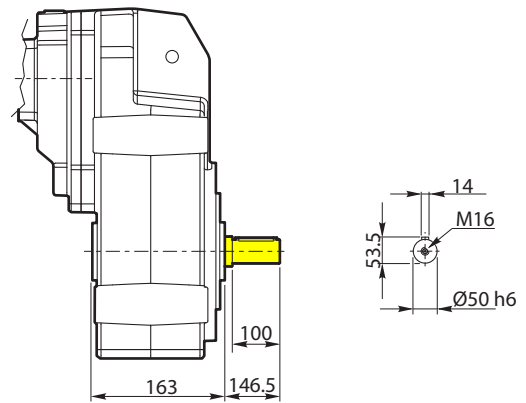

Flange uscita/ Output flange / Abtriebsflansch
 Bride de sortie / Brida de salida / Flange de saída

RFV 502 ... F...

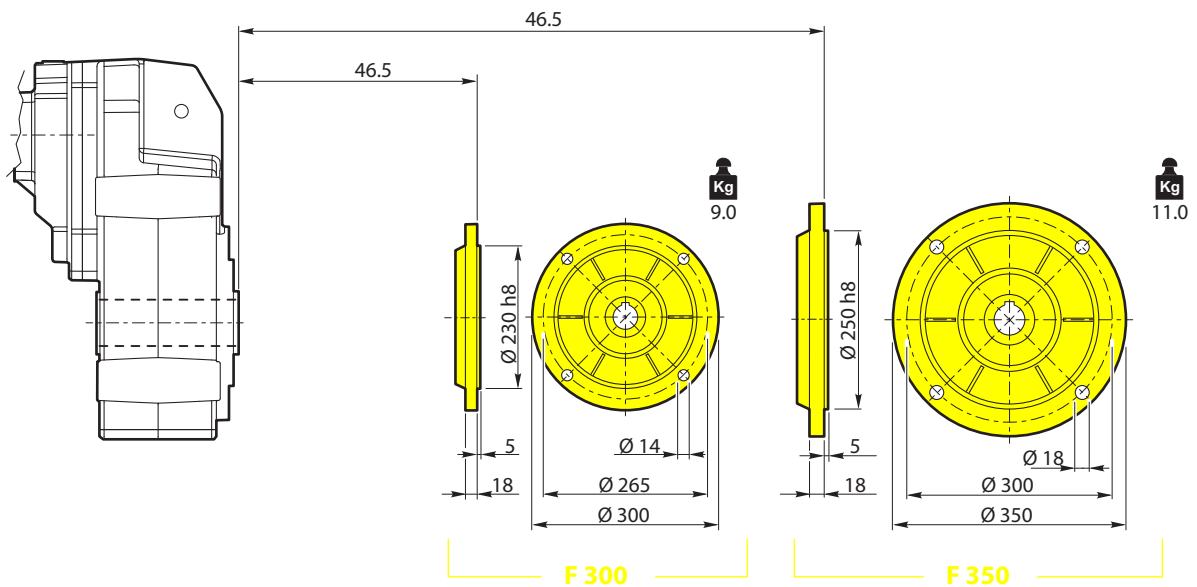

Dati tecnici riduttori/ Reducer technical data / Technische Daten Getriebe

Caractéristiques techniques reducteurs/ Datos técnicos reductores / Características técnicas ridutor

21

RFV	$n_1 = 2800 \text{ min}^{-1}$				$n_1 = 1400 \text{ min}^{-1}$			$n_1 = 900 \text{ min}^{-1}$			IEC B5	IEC B14	NEMA
	i	n_2 min ⁻¹	Mn_2 Nm	P_1 kW	n_2 min ⁻¹	Mn_2 Nm	P_1 kW	n_2 min ⁻¹	Mn_2 Nm	P_1 kW			
503	79.95	35	2200	8.68	18	2200	4.34	11	2200	2.79	71 80 90 100 112	90 100 112	140 TC 180 TC
	95.52	29	2200	7.26	15	2200	3.63	9.4	2200	2.33			
	105.43	27	2200	6.58	13	2200	3.29	8.5	2200	2.11			
	118.26	24	2200	5.87	12	2200	2.93	7.6	2200	1.89			
	134.39	21	2200	5.16	10	2200	2.58	6.7	2200	1.66			
	141.30	20	2200	4.91	9.9	2200	2.45	6.4	2200	1.58			
	155.95	18	2200	4.45	9.0	2200	2.22	5.8	2200	1.43			
	160.57	17	2200	4.32	8.7	2200	2.16	5.6	2200	1.39			
	177.23	16	2200	3.91	7.9	2200	1.96	5.1	2200	1.26			
	184.38	15	2200	3.76	7.6	2200	1.88	4.9	2200	1.21			
	194.88	14	2200	3.56	7.2	2200	1.78	4.6	2200	1.14			
	203.50	14	2200	3.41	6.9	2200	1.70	4.4	2200	1.10			
	232.84	12	2200	2.98	6.0	2200	1.49	3.9	2200	0.96			
	257.57	11	2200	2.69	5.4	2200	1.35	3.5	2200	0.87			
	307.74	9.1	2200	2.25	4.5	2200	1.13	2.9	2200	0.72			
	339.66	8.2	2200	2.04	4.1	2200	1.02	2.6	2200	0.66			



RFV 503 H...IEC

RFV 503 H...FV

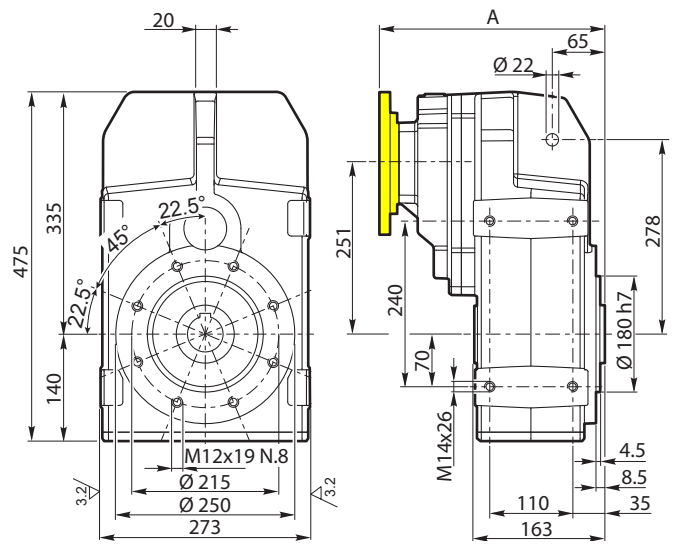

	A	kg
IEC 71-80-90-100-112	300	70
NEMA 140TC	309	
NEMA 180TC	315	72

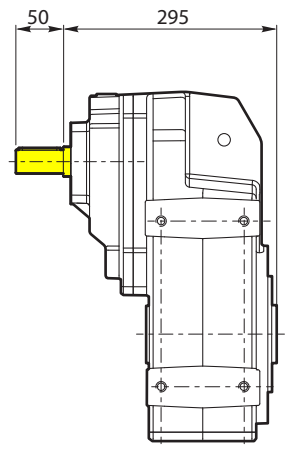

Albero uscita / Output shaft / Abtriebswelle

Albero entrata / Input shaft / Antriebswelle

Arbre de sortie / Eje de salida / Eixo de saída

Arbre d'entrée / Eje de entrada / Eixo de entrada

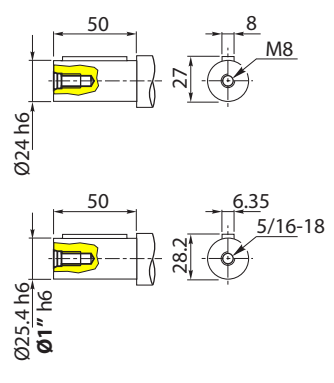
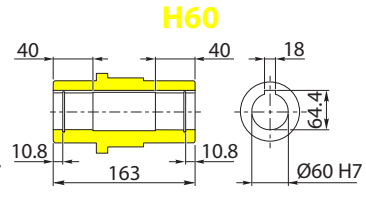
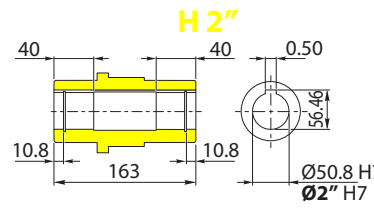
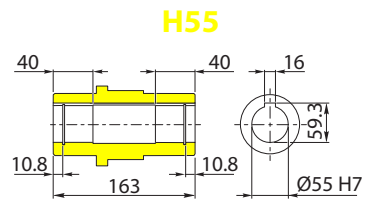
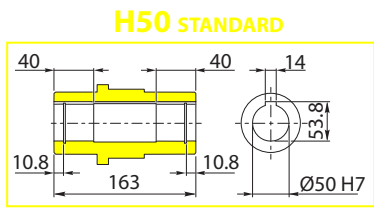



RFV 503 S...

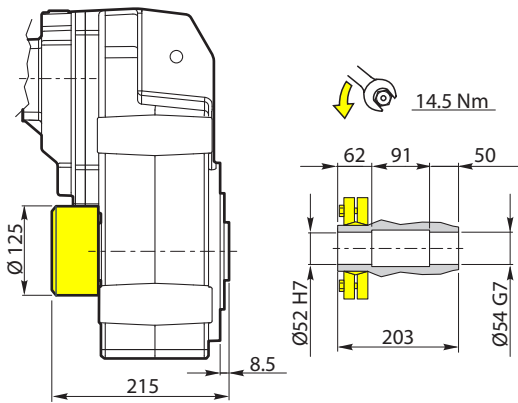

RFV 503 R...

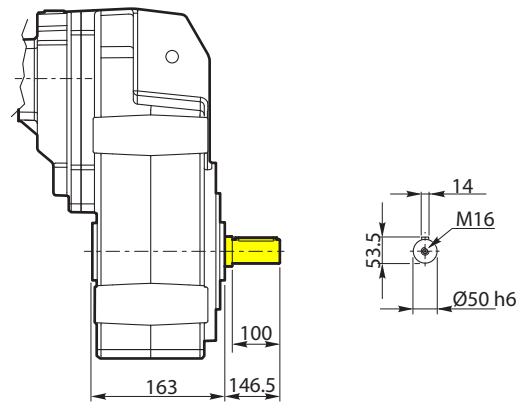

Flange uscita/ Output flange / Abtriebsflansch
 Bride de sortie / Brida de salida / Flange de saída

RFV 503 ... F...

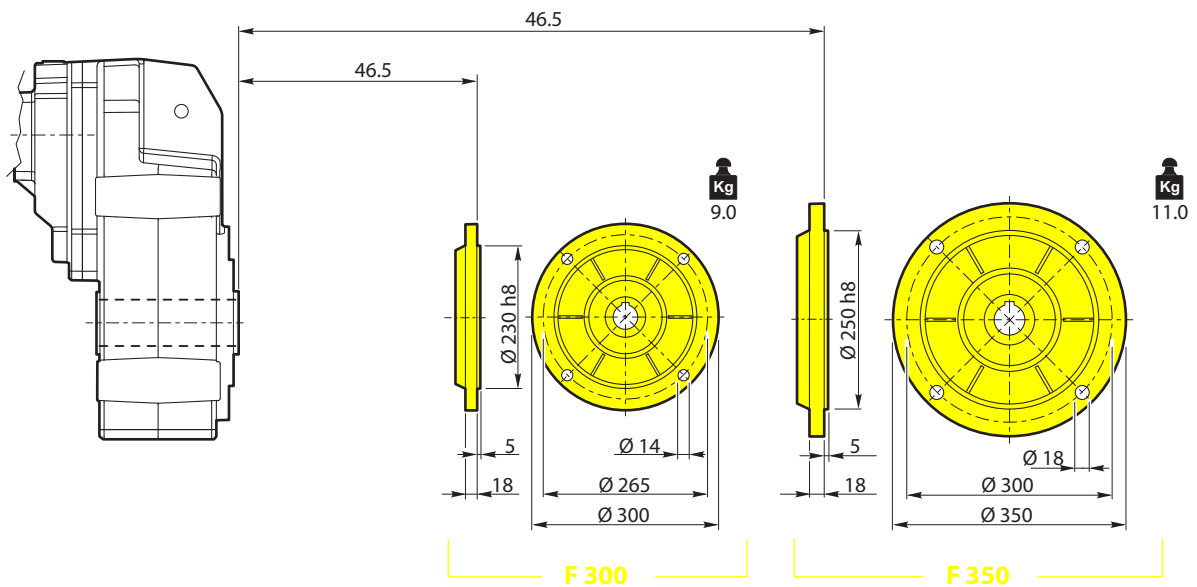



Kit fissaggio e smontaggio riduttori con albero lento cavo

Kit for mounting and dismantling gearboxes with hollow output shaft

Kit für Montage und Ausbau der Getriebe mit Abtriebshohlwelle

Kit de fixation et démontage des réducteurs avec arbre lent creux

Kit de fijación y desmontaje de los reductores con eje lento

Kit de fixação e desmontagem dos redutores com eixo lento oco

RFV										
	252-253		302-303		352-353		402-403		502-503	
C2	100.5		120		125		144		163	
D2	25	30	30	35	35	40	40	45	50	55
H	6.5	7	7	7	7	8	8	8	9	9
d1	—		—		—		—		M16	
d2	—		—		—		—		M8	
d3	M8	M10	M10		M10	M12	M12		—	
d4	M12	M14	M14		M14	M16	M16		—	
Z2	7.2	7.7	7.7	8.4	8.4	9.2	10.1	10.1	10.8	10.8
Lmax	84.5	83.5	103	102	107	105	123	123	140	140
Lmin	79.5	78.5	98	97	102	100	118	118	133	133

D2: Ø25 ÷ Ø45

Fissaggio / Mounting / Montage
Fixation / Fijación /

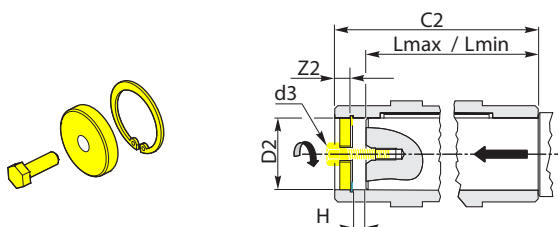

D2: Ø50 ÷ Ø55

Fissaggio / Mounting / Montage

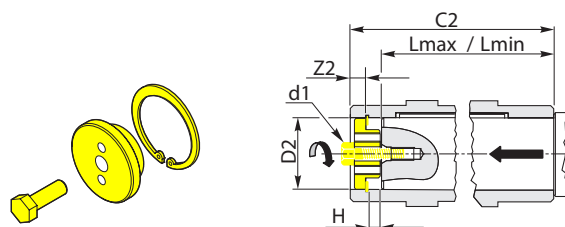

D2: Ø25 ÷ Ø45

Smontaggio / Dismantling / Demontage
Démontage / Desmontaje /

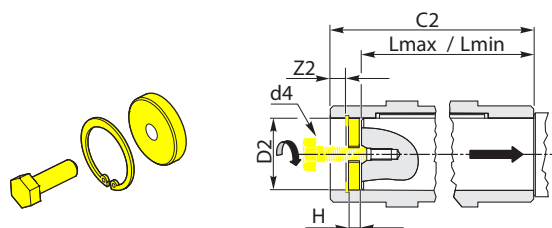

D2: Ø50 ÷ Ø55

Smontaggio / Dismantling / Demontage

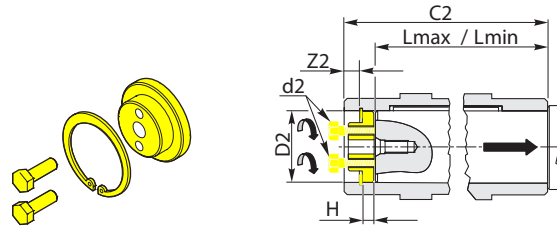



Kit antivibrante

Anti-vibration kit

Anti-vibrations-Kit

Kit anti-vibration

Kit antivibración

Kit anti-vibração

I riduttori pendolari serie RFV possono essere dotati, a richiesta, di un kit antivibrante che comprende i componenti necessari per il fissaggio pendolare (braccio di reazione escluso).
 Le dimensioni sono riportate nella tabella seguente.

*The RFV series shaft-mounted gearboxes can be equipped, on request, with an anti-vibration kit that includes the components required for mounting the gearbox (reaction arm excluded).
 The dimensions are shown in the table below.*

Die Pendelgetriebe der Serie RFV können auf Wunsch mit einem Anti-Vibrations-Kit ausgestattet werden, das die für die Pendelbefestigung notwendigen Komponenten enthält (ohne Reaktionsarm).
 Die Abmessungen sind in der nachstehenden Tabelle angegeben.

Les réducteurs pendulaires série RFV peuvent être dotés, sur demande, d'un kit anti-vibration qui comprend les composants nécessaires à la fixation pendulaire (bras de réaction exclu).
 Les dimensions sont reportées dans le tableau suivant.

*Los reductores pendulares de la serie RFV pueden equiparse bajo pedido con un kit antivibrante, que incluye los componentes necesarios para la fijación pendular (excluyendo el brazo de reacción).
 Las dimensiones se indican en la tabla siguiente.*

Os reductores pendulares da série RFV, mediante solicitação, podem ser dotados de kit antivibração que inclui os componentes necessários para a fixação pendular (braço de reação excluído).
 As dimensões estão apresentadas na tabela seguinte.

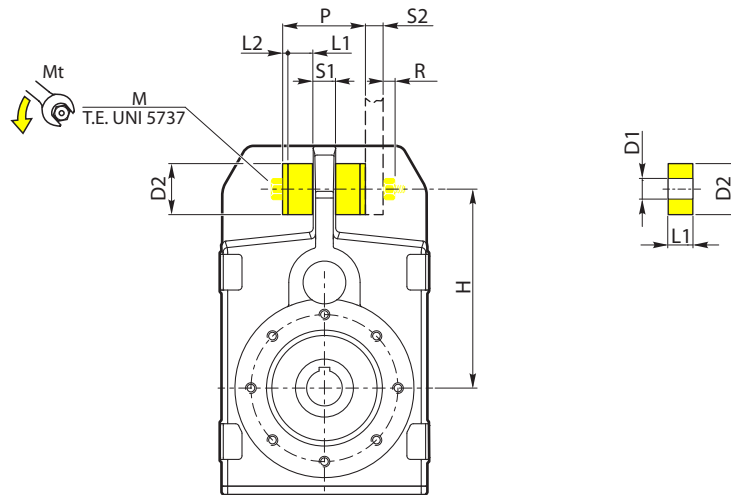

RFV	D1	D2	H	L1	L2	M	Mt (Nm)	P	R	S1	S2 (max)
252 253	11	30	140	15	2.5	M10x80	10	55	12.3	20	10
302 303	11	30	160	15	2.5	M10x80	10	55	12.3	20	10
352 353	12.5	40	170	20	2.5	M12x100	20	65	14.8	20	20
402 403	12.5	40	218	20	2.5	M12x100	20	65	14.8	20	24
502 503	21	60	278	30	5	M20x160	50	90	23	20	47



23

Perno macchina

Machine pin

Bolzen Maschine

Pivot machine

Perno de la máquina

Pino da máquina

Si consiglia di realizzare l'albero della macchina da azionare che si accoppierà con il riduttore pendolare, seguendo le indicazioni dimensionali delle due tabelle, forma costruttiva H - S.

Si suggerisce inoltre di completare il montaggio con un dispositivo che realizza il bloccaggio assiale dell'albero (vedi kit fissaggio/smontaggio).

It is advisable to install the shaft of the machine to be operated, which will be coupled with the shaft-mounted gearbox, by following the dimensional indications of the two tables, construction shape H - S.

It is also recommended to complete the assembly with a device that blocks the shaft axially (see mounting/dismantling kit).

Es wird empfohlen, die Welle der Maschine, die mit dem Pendelgetriebe gekoppelt wird, gemäß den Maßangaben der beiden Tabellen, Bauform H - S, herzustellen.

Ebenso ist es ratsam, die Baugruppe mit einer Vorrichtung zu vervollständigen, welche die Welle axial verriegelt (siehe Bausatzbefestigung /Demontage).

Il est conseillé de réaliser l'arbre de la machine à actionner qui s'accouplera avec le réducteur pendulaire, en suivant les indications de dimensions des deux tableaux, la forme de construction H - S.

Il est conseillé en outre de terminer le montage avec un dispositif qui réalise le blocage axial de l'arbre (voir le kit fixation/démontage).

Se recomienda realizar el eje de la máquina que se debe accionar, que se acoplará con el reductor pendular, siguiendo las indicaciones dimensionales de las dos tablas, forma de fabricación H - S.

Además se sugiere completar el montaje con un dispositivo que bloquea el eje de forma axial (véase el kit de fijación o de desmontaje).

É aconselhável realizar o eixo da máquina a ser acionada, que será acoplado com o redutor pendular, seguindo as indicações dimensionais das duas tabelas, forma construtiva H - S.

Além disso, é aconselhável completar a montagem com um dispositivo que realiza o bloqueio axial do eixo (ver o kit fixação/desmontagem).

H

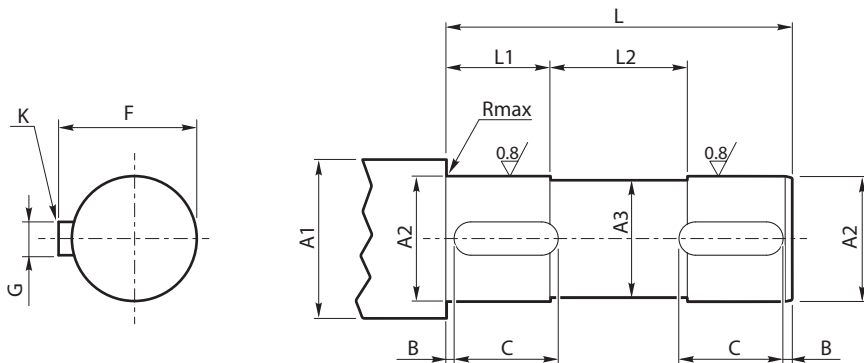

RFV	A1	A2	A3	B	C	F	G	K UNI 6604	L	L1	L2	R (max)
252	≥ 35	30 h7	29.5	2	25	33	8 h9	8x7x25 A	83.5	25	33.5	0.5
253	≥ 30	25 h7	24.5	2	25	28	8 h9	8x7x25 A	84.5	25	34.5	0.5
302	≥ 42	35 h7	34.5	2	30	38	10 h9	10x8x30 A	102	30	42	0.5
303	≥ 35	30 h7	29.5	2	30	33	8 h9	8x7x30 A	103	30	43	0.5
352	≥ 47	40 h7	39.5	2	30	43	12 h9	12x8x30 A	105	30	45	0.5
353	≥ 42	35 h7	34.5	2	30	38	10 h9	10x8x30 A	107	30	47	0.5
402	≥ 52	45 h7	44.5	2.5	50	49.5	14 h9	14x9x45 A	123	35	53	1
403	≥ 47	40 h7	39.5	2.5	50	43	12 h9	12x8x45 A	123	35	53	1
502	≥ 63	55 h7	54.5	2.5	60	59	16 h9	16x10x50 A	140	40	60	1
503	≥ 57	50 h7	49.5	2.5	60	53.5	14 h9	14x9x50 A	140	40	60	1



Perno macchina
Machine pin
Bolzen Maschine
Pivot machine
Perno de la máquina
Pino da máquina

S

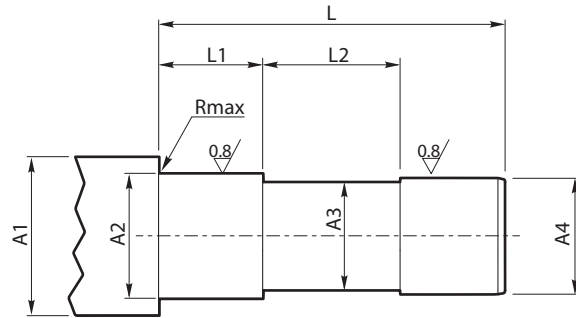

RFV	A1	A2	A3	A4	L	L1	L2	R (max)
252 253	≥ 36	27 h7	24	25 h6	138	34	70	0.5
302 303	≥ 42	32 h7	29	30 h6	160	38	84	0.5
352 353	≥ 50	38 h7	35	36 h6	155	40	73	1
402 403	≥ 58	44 h7	41	42 h6	177	46.5	82	1
502 503	≥ 68	54 h7	51	52 g6	201	48	91	1

Coperchio di tenuta
Sealing cover
Dichtungsdeckel
Couvercle d'étanchéité
Cubierta de sellado
Tampa de vedação

CT

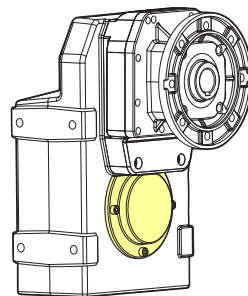
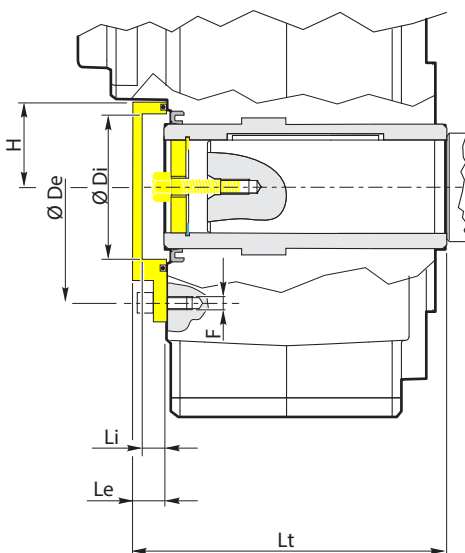

RFV	De	Di	F	H	Li	Le	Lt
252 253	90	50	M6x12	30	15	20	119
302 303	100	55	M6x12	32.5	15	20	138
352 353	105	62	M6x12	39	15	20	144
402 403	120	73	M6x12	44.5	15	20	161
502 503	145	90	M6x12	53.5	20	25	185



Atex / Atex / Atex

Atex / Atex / Atex



24

I riduttori pendolari Varmec possono essere forniti per consentirne l'utilizzo in zone con atmosfere potenzialmente esplosive, conformi alla direttiva europea ATEX 2014/34/UE.

In base ai criteri di classificazione forniti dalla direttiva stessa, i riduttori coassiali sono conformi alle richieste di progetto estratte dal Gruppo II, Categoria 2-3, per funzionamento in aree con pericolo di esplosione in presenza di gas "G" e di polveri combustibili "D".

In conseguenza alla loro classificazione nelle categorie 2GD-3GD, ed in conformità a quanto specificato dalla direttiva, i riduttori sono installabili nelle aree con presenza di miscele gassose esplosive - zone 1-2, e nelle aree con presenza di polveri combustibili - zone 21-22.

La loro temperatura superficiale non deve superare i 130°C classe temperatura T4, sono destinati a un impiego industriale con temperatura ambiente da -20°C a +40°C e con una velocità in entrata non superiore ai 1500 rpm.

I riduttori della grandezza RFV 502/3 vengono forniti con tappo di sfiato con valvola anti-intrusione e tappo livello olio, le restanti grandezze RFV 252/3 - 302/3 - 352/3 - 402/3 vengono fornite standard senza alcun tappo.

Tutte le grandezze dei riduttori sono fornite con olio lubrificante sintetico ISO VG 320.

Varmec shaft-mounted gearboxes can be supplied for use in potentially explosive atmospheres, in line with the ATEX 2014/34/EU directive.

Based on the classification criteria provided in the directive itself, coaxial gear reducers meet the design requirements extracted from Group II, Category 2-3, for operation in areas with an explosion hazard in the presence of gas "G" or combustible powders "D".

Following their classification in categories 2GD-3GD and in accordance with the directive's specifications, the gear reducers can be installed in areas with a presence of explosive gas mixes (zones 1-2) and in areas with combustible powders (zones 21-22).

Their surface temperature must not exceed 130°C, temperature class T4. They are intended for industrial use with a room temperature from -20°C to +40°C and with an infeed speed not higher than 1500 rpm.

The RFV 502/3 gear reducers are supplied with a drain plug fitted with an anti-intrusion valve and an oil level plug. Remaining RFV 252/3 - 302/3 - 352/3 - 402/3 models are supplied as standard without any plug.

All gear reducer sizes are supplied with ISO VG 320 synthetic lubricant oil.

Die Aufsteckgetriebe von Varmec können für den Einsatz in explosionsgefährdeten Bereichen in Übereinstimmung mit der europäischen Richtlinie ATEX 2014/34/EU geliefert werden.

Gemäß den Einstufungskriterien der Richtlinie entsprechen die koaxialen Getriebe den Projektanforderungen der Gruppe II, Kategorie 2-3, für den Einsatz in explosionsgefährdeten Bereichen in Gegenwart von Gas "G" und brennbaren Stäuben "D".

Infolge ihrer Einstufung in den Kategorien 2GD-3GD, und in Übereinstimmung mit den Vorgaben der Richtlinie können die Getriebe in Bereichen mit Anwesenheit von explosiven Gasgemischen - Zonen 1-2, und in Bereichen mit brennbarem Staub - Zonen 21-22 eingesetzt werden.

Ihre Oberflächentemperatur darf 130 ° C Temperaturklasse T4 nicht überschreiten; sie sind für einen industriellen Einsatz mit Umgebungstemperatur von -20°C bis +40°C und mit einer Eingangsdrehzahl von nicht mehr als 1500 rpm bestimmt.

Die Getriebe der Größe RFV 502/3 werden mit Entlüfterstutzen mit Einbruchschutz-Ventil und Ölstandsschraube geliefert; die anderen Größen RFV 252/3 - 302/3 - 352/3 - 402/3 werden standardmäßig ohne jeglichen Verschluss geliefert. Alle Getriebegrößen werden mit synthetischem Schmieröl ISO VG 320 geliefert.

Il manuale di installazione uso e manutenzione è parte integrante della fornitura di ogni riduttore Atex; ogni indicazione in esso contenuta deve essere scrupolosamente applicata.

Per la determinazione della grandezza riduttore procedere come indicato nel paragrafo relativo alla Scelta (vedi pag. 12), e selezionare il riduttore con fattore di servizio ≥ 1 .

The installation, operation and maintenance manual is an integral part of each Atex gear reducer and each indication given in said manual must be scrupulously followed. In order to determine the size of the gear reducer proceed as indicated in the selection chapter (see pg. 12) and choose a gear reducer with a service factor $f_s \geq 1$.

Das Installations- und Wartungshandbuch ist im Lieferumfang von jedem ATEX-Getriebe enthalten, die Anleitung muß jedoch genauestens befolgt werden.

Die Auswahl der Getriebegröße ist im Abschnitt zur Getriebeauswahl beschrieben (s. Seite.12) und sollte beachtet werden. Es ist das Getriebe mit dem Betriebsfaktor auszuwählen, welcher ≥ 1 .

Verificare che la Potenza richiesta sia \leq della potenza termica (vedi pag. 10).

Per maggiori indicazioni sulle normative Atex, consultare il manuale di installazione uso e manutenzione, scaricabile dal nostro sito internet oppure interpellatici.

Please check that the required power is \leq than the thermic power (see pg. 10).

For more information on Atex norms consult the installation, operation and maintenance manual that can be downloaded from our Internet site or contact us directly.

Es ist zu überprüfen, dass die benötigte Leistung \leq der thermischen Leistung ist (siehe Seite.10).

Weitere Details zur ATEX- Norm können Sie im Installations- und Wartungshandbuch Nachschlagen. Dieses finden im Internet, auch zum herunterladen, unter www.varmec.de. Für weitere Informationen wenden Sie sich bitte direkt an uns.

In conformità alla Direttiva Atex 2014/34/UE, le serie di riduttori coassiali VARMEC- ATEX sono marcate

Ex II 2GD Exh IIC T4 Gb Exh IIIC T135° C Db IP66
Ex II 3GD Exh IIC T4 Gb Exh IIIC T135° C Dc IP66

In accordance with ATEX Directive 2014/34/EU, the series of VARMEC-ATEX coaxial gear reducers are marked as

Ex II 2GD Exh IIC T4 Gb Exh IIIC T135° C Db IP66
Ex II 3GD Exh IIC T4 Gb Exh IIIC T135° C Dc IP66

Gemäß ATEX-Richtlinie 2014/34/UE, ist die Serie der koaxialen Getriebe VARMEC- ATEX gekennzeichnet mit

Ex II 2GD Exh IIC T4 Gb Exh IIIC T135° C Db IP66
Ex II 3GD Exh IIC T4 Gb Exh IIIC T135° C Dc IP66



Les réducteurs pendulaires Varmec peuvent être fournis pour en permettre l'utilisation dans les zones à risque d'explosion, conformément à la directive européenne ATEX 2014/34/UE.

Selon les critères de classification prévus par la directive, les réducteurs coaxiaux répondent aux exigences du projet correspondant au Groupe II, Catégorie 2-3, pour le fonctionnement dans des lieux présentant des risques d'explosion en présence de gaz « G » et de poussières combustibles « D ».

Par conséquent, leur classification dans les catégories 2GD-3GD, et conformément à ce qui est spécifié par la directive, les réducteurs peuvent être installés dans des zones en présence de mélanges gazeux explosifs - zones 1-2, et dans des zones où il y a des poussières combustibles - zones 21-22.

Leur température de surface ne doit pas dépasser 130 °C classes de température T4, ils sont destinés à une utilisation industrielle avec une température ambiante de -20 °C à +40 °C et avec une vitesse d'entrée ne dépassant pas 1 500 tours/minute.

Les réducteurs de la taille RFV 502/3 sont fournis avec un bouchon de purge avec vanne anti-intrusion et un bouchon niveau d'huile, les tailles restantes RFV 252/3 - 302/3 - 352/3 - 402/3 sont fournies en standard sans aucun bouchon.

Toutes les tailles des réducteurs sont fournies avec de l'huile lubrifiante synthétique ISO VG 320.

Le manuel d'installation, d'utilisation et de maintenance fait partie intégrante de la fourniture de chaque réducteur Atex ; chaque indication doit être scrupuleusement appliquée.

Pour déterminer la taille du réducteur procéder comme indiqué dans le paragraphe relatif à la sélection (pag.13), et sélectionner le réducteur avec facteur de service ≥ 1 des valeurs indiquées dans le tableau 6.

Vérifier que la puissance demandée soit \leq de la puissance thermique (pag. 11).

Pour plus d'indications sur les normes Atex, consulter le manuel d'installation, utilisation et maintenance disponible sur notre site web

Conformément à la directive Atex 2014/34/UE, les séries de réducteurs coaxiaux VARMEC - ATEX sont marquées

Ⓔ II 2GD Exh IIC T4 Gb Exh IIIC T135° C Db IP66
Ⓔ II 3GD Exh IIC T4 Gb Exh IIIC T135° C Dc IP66

Los reductores pendulares Varmec pueden suministrarse para permitir su uso en zonas con atmósferas potencialmente explosivas, en conformidad con la directiva europea ATEX 2014/34/UE.

Sobre la base de los criterios de clasificación indicados en la propia directiva, los reductores coaxiales están en conformidad con los requisitos de proyecto extraídos del Grupo II, Categoría 2-3, para el funcionamiento en áreas con peligro de explosión en presencia de gases "G" y de polvos combustibles "D". En consecuencia a su clasificación en las categorías 2GD-3GD y de acuerdo con cuanto especifica la directiva, los reductores pueden instalarse en las áreas con presencia de mezclas gaseosas explosivas -zonas 1-2- y en las áreas con presencia de polvos combustibles, zonas 21-22.

Su temperatura superficial no debe superar los 130°C clase de temperatura T4; están destinados a un uso industrial con una temperatura ambiente que oscile entre -20°C y +40°C y con una velocidad de entrada no superior a las 1.500 rpm.

Los reductores del tamaño RFV 502/3 se suministran equipados con tapón de purga con válvula contra intrusiones y tapón de nivel de aceite; los restantes tamaños RFV 252/3 - 302/3 - 352/3 - 402/3 son estándares y se suministran sin ningún tapón.

Todos los tamaños de los reductores se suministran con aceite lubricante sintético ISO VG 320.

El manual de instalación, uso y mantenimiento forma parte de los accesorios de cada reductor Atex, las indicaciones en este contenidas deben ser respetadas rigurosamente en su aplicación. Para la determinación de la grandezza de la reducción proceder como indica el párrafo relativo a la selección y elegir el reductor con el factor de servicio ≥ 1 de los valores indicados en la tabla 6.

Verificar que la potencia requerida sea $<$ de la potencia térmica /ver pag.11).

Para mayor información sobre la norma Atex, consultar el manual de instalación, uso y mantenimiento o visitar nuestro sitio en Internet.

En conformidad con la Directiva Atex 2014/34/UE, las series de reductores coaxiales VARMEC - ATEX cuenta con el marcado

Ⓔ II 2GD Exh IIC T4 Gb Exh IIIC T135° C Db IP66
Ⓔ II 3GD Exh IIC T4 Gb Exh IIIC T135° C Dc IP66

Os redutores pendulares Varmec podem ser fornecidos para permitir o uso em áreas com atmosferas potencialmente explosivas, em conformidade com a diretiva europeia ATEX 2014/34/UE.

De acordo com os critérios de classificação fornecidos pela própria diretiva, os redutores coaxiais estão em conformidade com as requisições de projeto extraídas do Grupo II, Categoria 2-3, para o funcionamento em áreas com perigo de explosão em presença de gás "G" e de pós combustíveis "D". Como resultado de sua classificação nas categorias 2GD-3GD e em conformidade às especificações da diretiva, os redutores podem ser instalados em áreas com presença de misturas de gases explosivos (zonas 1-2) e em áreas com presença de pó combustível - áreas 21-22.

A temperatura da superfície não deve exceder 130°C, classe de temperatura T4; são destinados ao uso industrial com temperatura ambiente de -20°C a + 40°C e velocidade em entrada não superior a 1500 rpm.

Os redutores de tamanho RFV 502/3 são fornecidos com tampão de purga com válvula anti-intrusão e tampão de nível de óleo; os outros modelos: RFV 252/3 - 302/3 - 352/3 - 402/3 são fornecidos sem algum tipo de tampão no fornecimento padrão.

Todos os tamanhos dos redutores são fornecidos com óleo lubrificante sintético ISO VG 320.

O manual de instalação uso e manutenção é parte integrante da forniture de cada ridutor Atex. Cada indicação que contém deve ser escrupolosamente aplicada

Para a determinação da grandezza ridutor continua como indicado no paragrafo relativo a escolha (ver pag. 13), e selecionar o ridutor com fator de serviço ≥ 1 do valor indicado na tabela 6.

Verifique se a potência exigida é $<$ do que a potência térmica (veja a página 11).

Para maiores indicações sobre as normas ATEX, consulte o manual de instalação, uso e manutenção, que pode ser descarregado do nosso site internet, ou entre em contato conosco.

Em conformidade com a diretiva Atex 2014/34/UE, as séries de redutores coaxiais VARMEC- ATEX são marcados

Ⓔ II 2GD Exh IIC T4 Gb Exh IIIC T135° C Db IP66
Ⓔ II 3GD Exh IIC T4 Gb Exh IIIC T135° C Dc IP66



Parti di ricambio / Spare parts list / Ersatzteilliste

Liste des pieces detachees / Lista de recambios / Lista de recambios

25

252

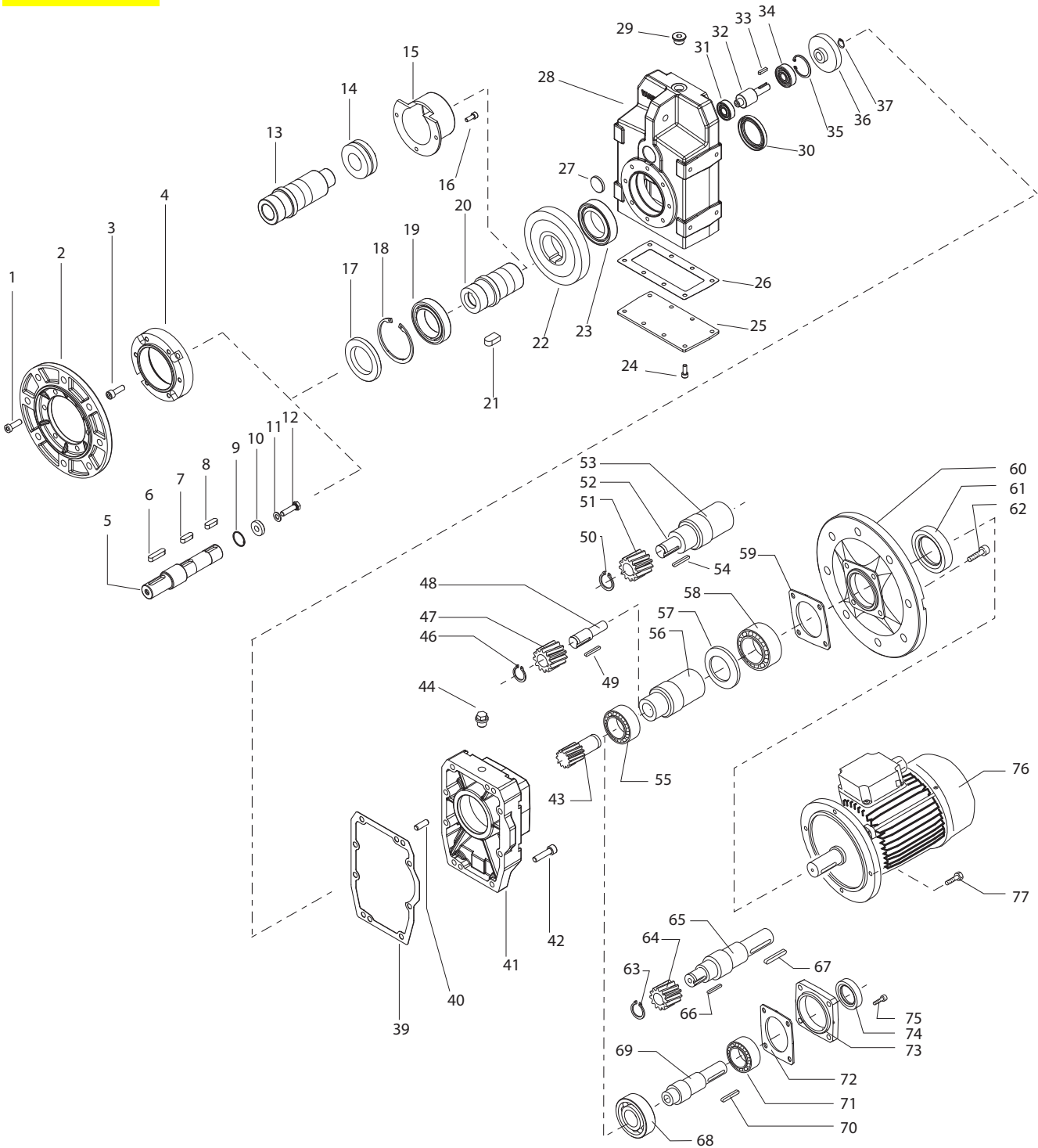

RFV	Cuscinetti / Bearings / Lager Roulements / Rodamientos / Rolamentos								Anelli di tenuta / Oilseals / Öldichtungen Bagues d'étanchéité / Retenes / Retentores				
	19	23	31	34	55	58	68	71	17	30	61	74	
252		6009	6009	6201	6301	6205	6007	-	-	45/75/8	45/60/7	35/56/8	-
						-	-	6205	6206			-	30/47/7



253

25

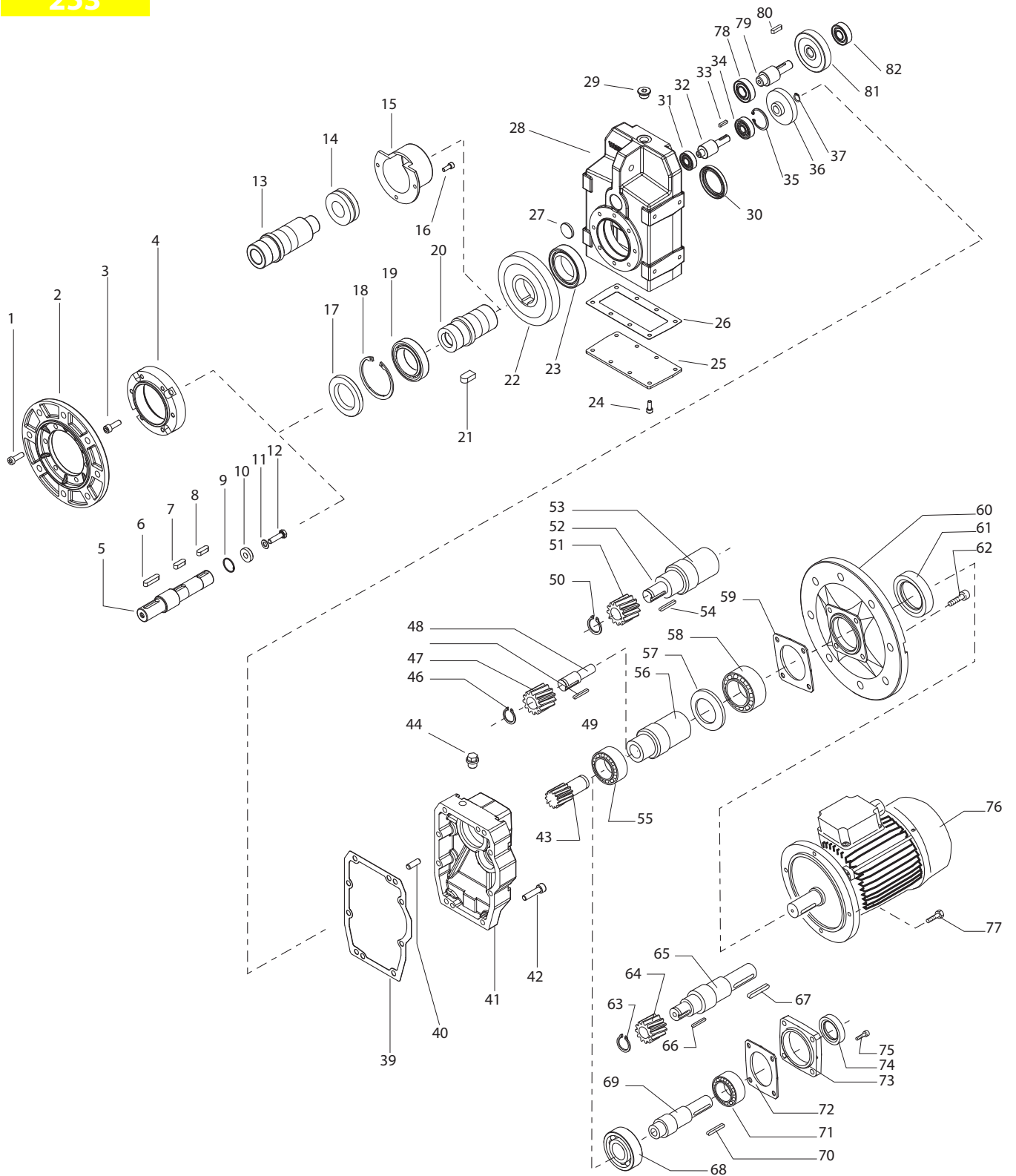

RFV	Cuscinetti / Bearings / Lager Roulements / Rodamientos / Rolamentos								Anelli di tenuta / Oilseals / Öldichtungen Bagues d'étanchéité / Retenes / Retenores						
	19	23	31	34	55	58	68	71	78	82	17	30	61	74	
253	IEC	6009	6009	6201	6301	6004	6005	-	-	6001	6000	45/75/8	45/60/7	25/40/7	-
							6004	6204						-	20/35/7



Parti di ricambio / Spare parts list / Ersatzteilliste

Liste des pieces detachees / Lista de recambios / Lista de recambios

25

302

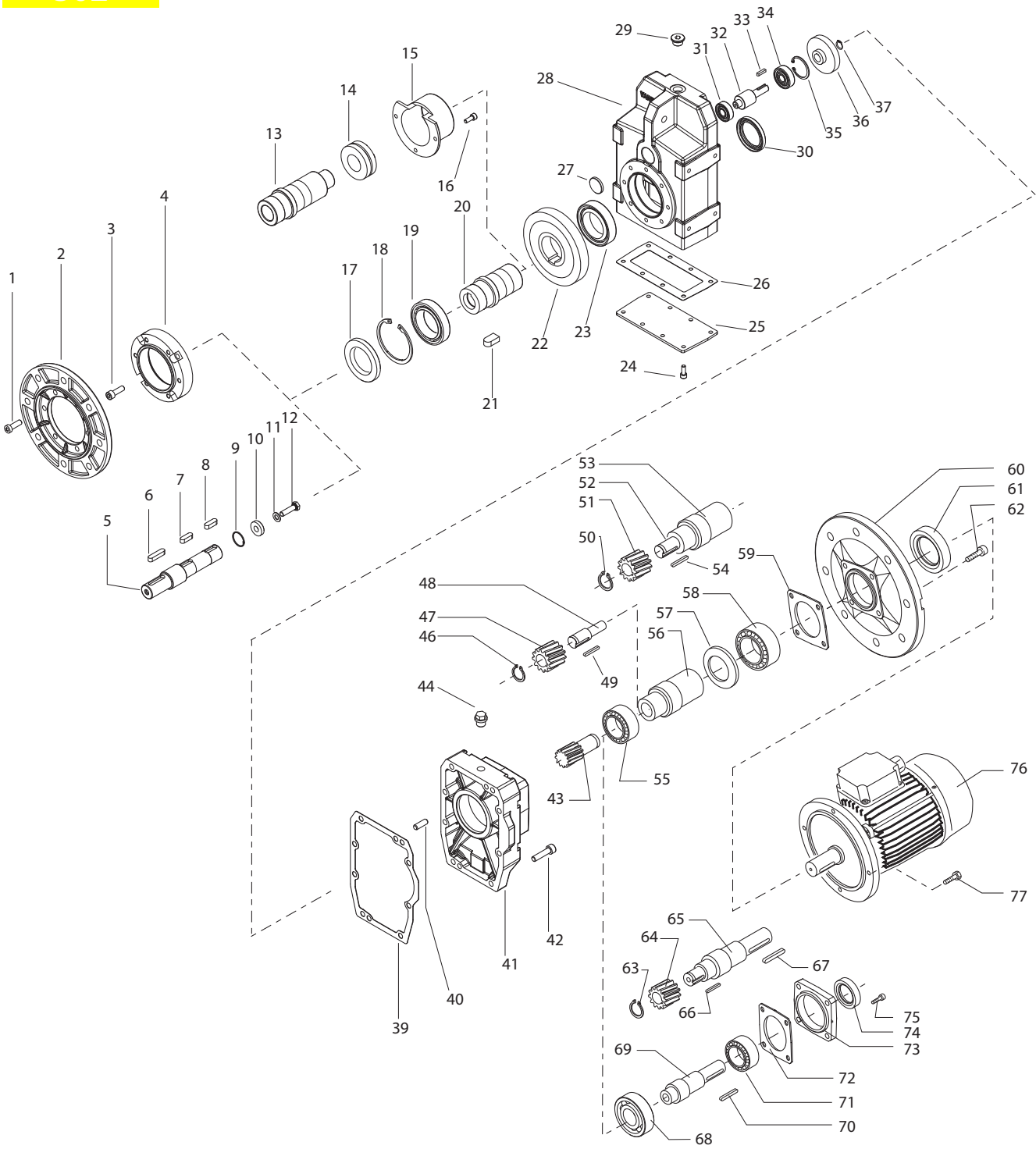

RFV		Cuscinetti / Bearings / Lager Roulements / Rodamientos / Rolamentos								Anelli di tenuta / Oilseals / Öldichtungen Bagues d'étanchéité / Retenes / Retentores				
		19	23	31	34	55	58	68	71	17	30	61	74	
302	IEC	100 / 112					6205	6009	-	-			45/62/7	-
		63 / 71 / 80 / 90	6010	6010	6301	6302		6007			50/80/8	50/65/8	35/56/8	
		Ø19x40					-	-	6205	6206			-	30/47/7



Parti di ricambio / Spare parts list / Ersatzteilliste
 Liste des pieces detachees / Lista de recambios / Lista de recambios

303

25

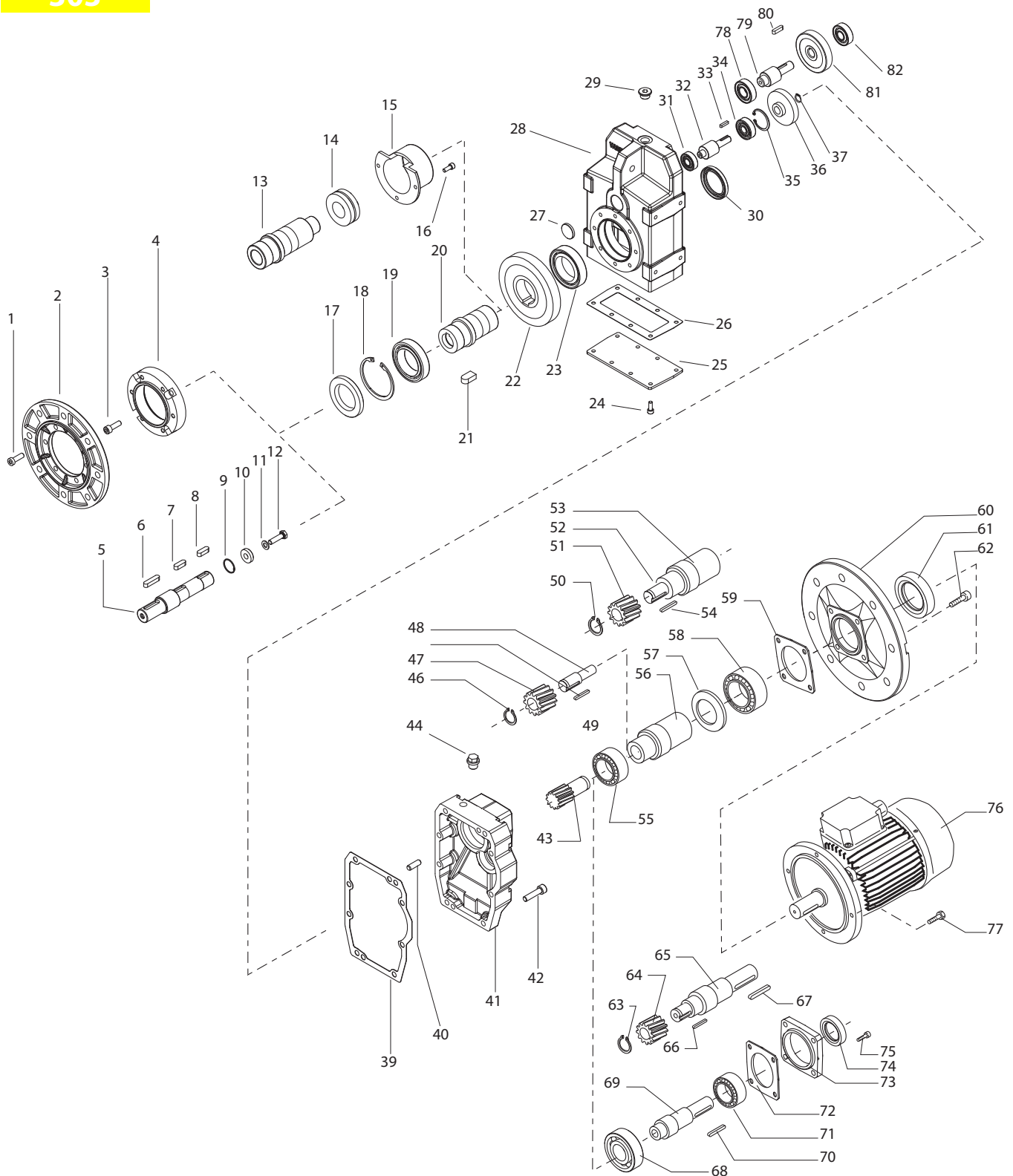

RFV	Cuscinetti / Bearings / Lager Roulements / Rodamientos / Rolamentos								Anelli di tenuta / Oilseals / Öldichtungen Bagues d'étanchéité / Retenes / Retenores						
	19	23	31	34	55	58	68	71	78	82	17	30	61	74	
303	IEC	6010	6010	6301	6302	6004	6005	-	-	6201	6201	50/80/8	50/65/8	25/40/7	-
								6004	6204					-	20/35/7



Parti di ricambio / Spare parts list / Ersatzteilliste

Liste des pieces detachees / Lista de recambios / Lista de recambios

25

352

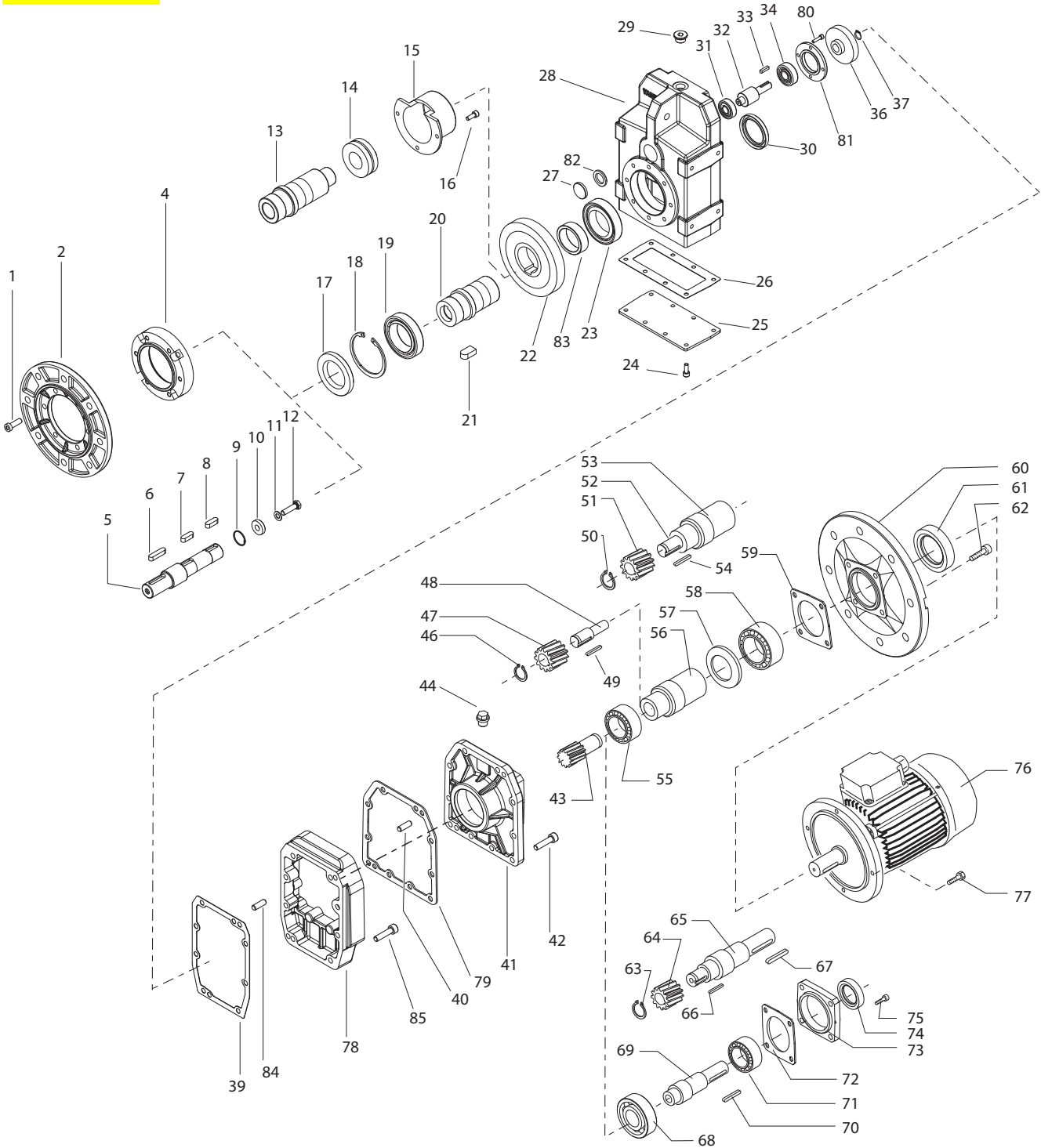

RFV	Cuscinetti / Bearings / Lager Roulements / Rodamientos / Rolamentos								Anelli di tenuta / Oilseals / Öldichtungen Bagues d'étanchéité / Retenes / Retentores			
	19	23	31	34	55	58	68	71	17	30	61	74
352	IEC 132				NJ 206	6011					55/80/8 *	
	100 / 112				6206	6009	-	-			45/62/7	-
	63 / 71 / 80 / 90	6211	6011	30204	30204	6305	6007		55/100/10	55/72/8	35/56/8	
	Ø19x40							6305	6206			30/47/7
							6206	6009				35/62/7

*: Viton



353

25

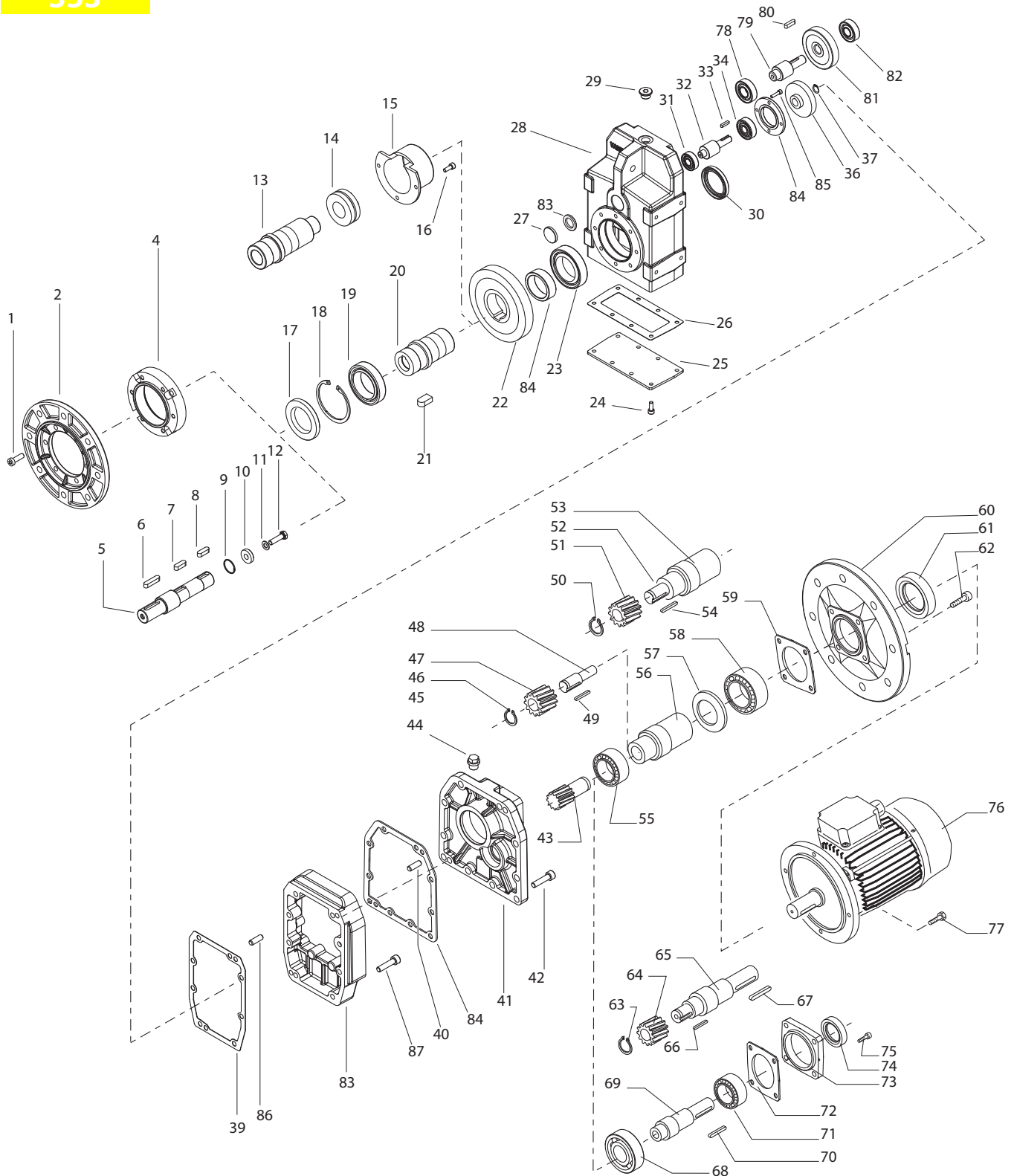

RFV	Cuscinetti / Bearings / Lager Roulements / Rodamientos / Rolamentos								Anelli di tenuta / Oilseals / Öldichtungen Bagues d'étanchéité / Retenes / Retenores						
	19	23	31	34	55	58	68	71	78	82	17	30	61	74	
353		6211	6011	30204	30204	6205	6007	-	-	6301	6201	55/100/10	55/72/8	35/56/8	-
								6205	6206					-	30/47/7



Parti di ricambio / Spare parts list / Ersatzteilliste

Liste des pieces detachees / Lista de recambios / Lista de recambios

25

402

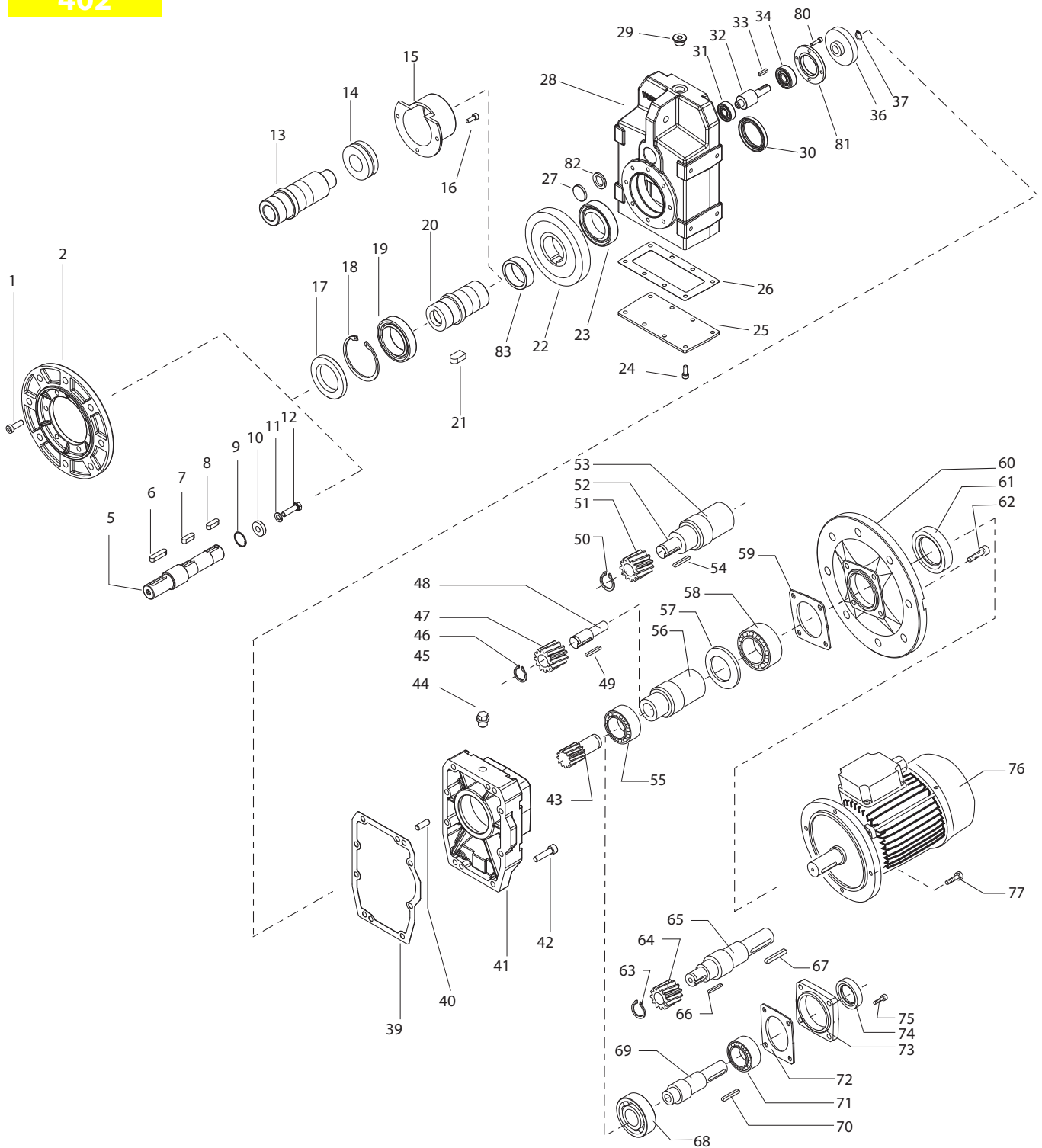

RFV	Cuscinetti / Bearings / Lager Roulements / Rodamientos / Rolamentos								Anelli di tenuta / Oilseals / Öldichtungen Bagues d'étanchéité / Retenes / Retentores					
	132	19	23	31	34	55	58	68	71	17	30	61	74	
402	IEC	132				6207	6011					55/80/8 *		
	IEC	71 / 80 / 90 100 / 112	6213	6013	32006	32006	6206	6009	-	-	65/120/13	65/85/10	45/62/7	-
		Ø24x50							6206	6009				35/62/7
	IEC	Ø28x60							NJ 207	6308			40/52/7	

*: Viton



Parti di ricambio / Spare parts list / Ersatzteilliste
 Liste des pieces detachees / Lista de recambios / Lista de recambios

403

25

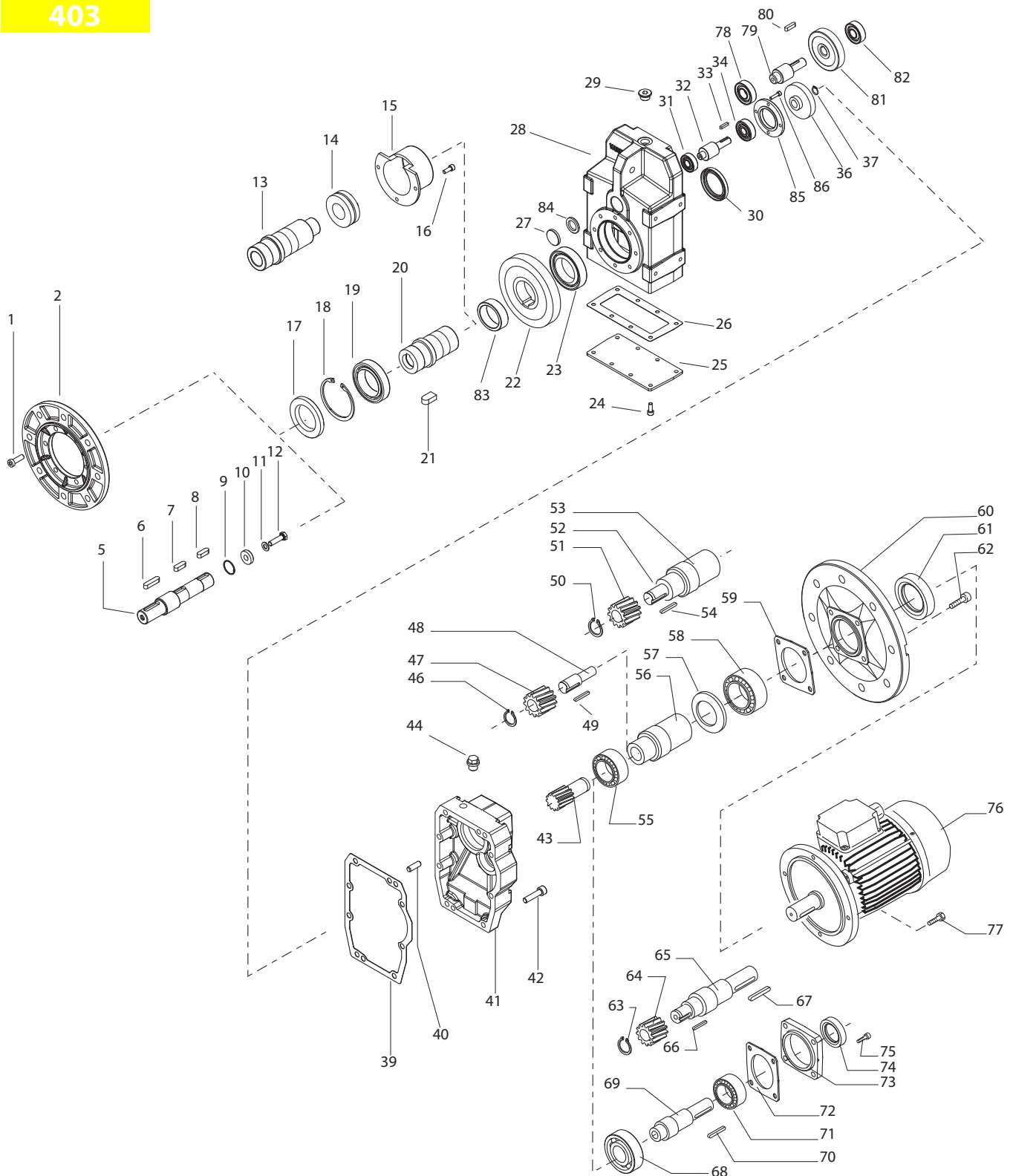

RFV	Cuscinetti / Bearings / Lager Roulements / Rodamientos / Rolamentos								Anelli di tenuta / Oilseals / Öldichtungen Bagues d'étanchéité / Retenes / Retentores						
	19	23	31	34	55	58	68	71	78	82	17	30	61	74	
403		6213	6013	32006	32006	6205	6007	-	-	6304	6303	65/120/13	65/85/10	35/56/8	-
								6205	6206					-	30/47/7







Parti di ricambio / Spare parts list / Ersatzteilliste

Liste des pieces detachees / Lista de recambios / Lista de recambios

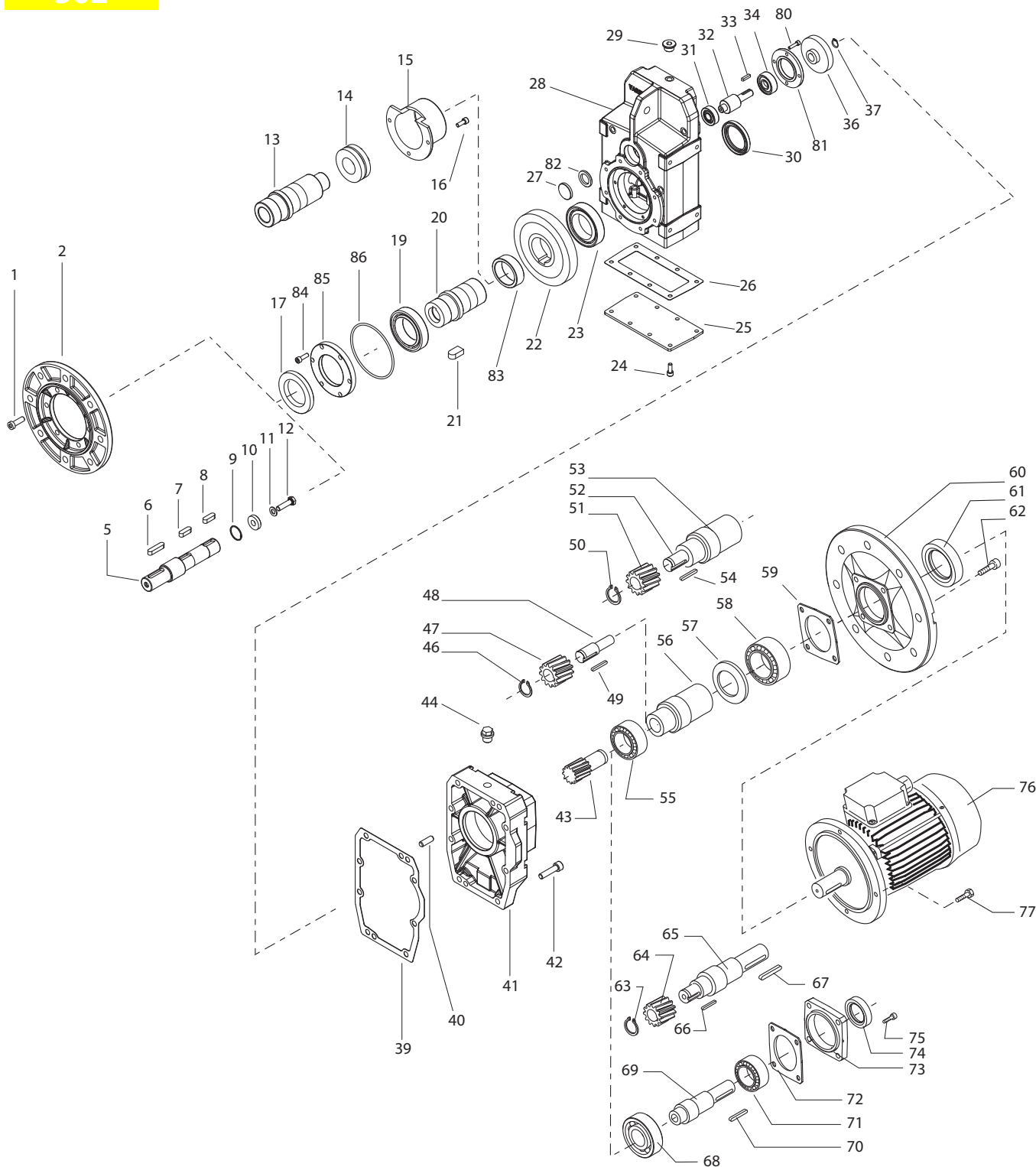
25

502



RFV		Cuscinetti / Bearings / Lager Roulements / Rodamientos / Rolamentos						Anelli di tenuta / Oilseals / Öldichtungen Bagues d'étanchéité / Retenes / Retentores					
		19	23	31	34	55	58	68	71	17	30	61	74
502	IEC 160 - 180					6309	6014					70/90/10 * (n° 2)	
	 80 / 90 / 100 112 / 132	6215	6215	32207	32207	6207	6011	-	-			55/80/8 *	-
	 Ø28x60	33116 ⁽¹⁾	33116 ⁽¹⁾					NJ 207	6308	75/100/10	75/100/10		40/52/7
	 Ø38x80							NJ 309	6310				50/90/10

(1) albero uscita Ø60 / Output shaft Ø60 / Abtriebswelle Ø60 / Arbre de sortie Ø60 / Eje de salida Ø60 / Eixo de saída Ø60



* : Viton

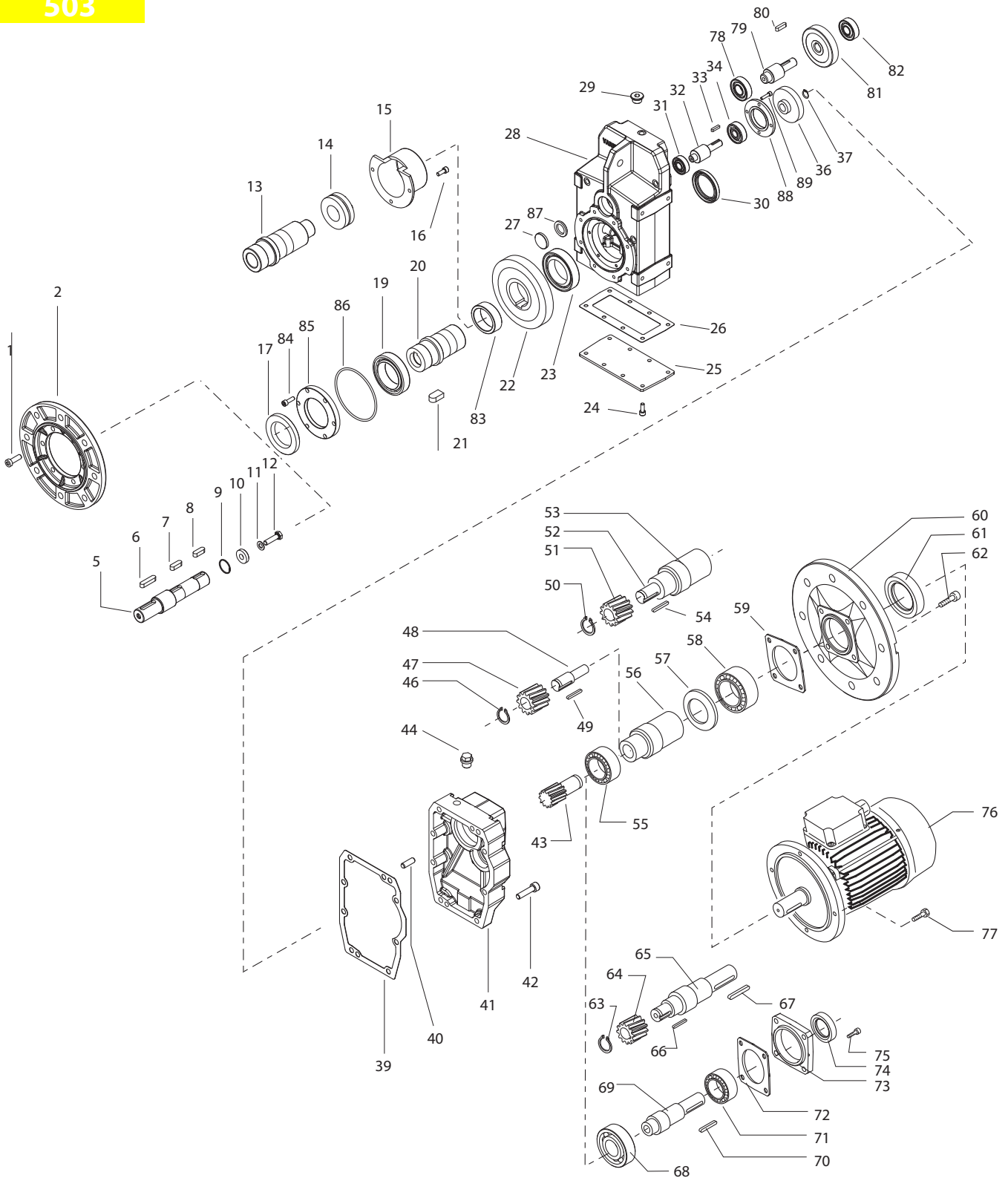

503

25



RFV	Cuscinetti / Bearings / Lager Roulements / Rodamientos / Rolamentos										Anelli di tenuta / Oilseals / Öldichtungen Bagues d'étanchéité / Retenes / Retentores				
	19	23	31	34	55	58	68	71	78	82	17	30	61	74	
503		6215	6215	32207	32207	6206	6009	-	-	30204	30204	75/100/10	75/100/10	45/62/7	-
		33116 ⁽¹⁾	33116 ⁽¹⁾					6206	6009					-	35/62/7

(1) albero uscita Ø60 / Output shaft Ø60 / Abtriebswelle Ø60 / Arbre de sortie Ø60 / Eje de salida Ø60 / Eixo de saida Ø60



Motori elettrici / Electric motors / Elektromotoren
 Moteurs électriques / Motores electricos / Motores electricos

Motore elettrico trifase / Threephase electric motor / Drehstrommotor
 Moteur électrique triphasé / Motor eléctrico trifásico / Motor eléctrico trifásico

B5

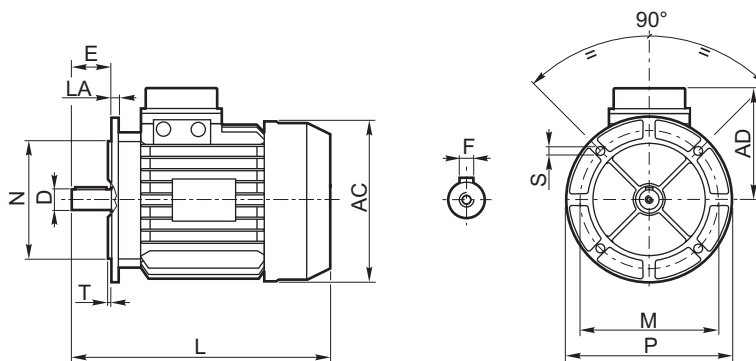

B14

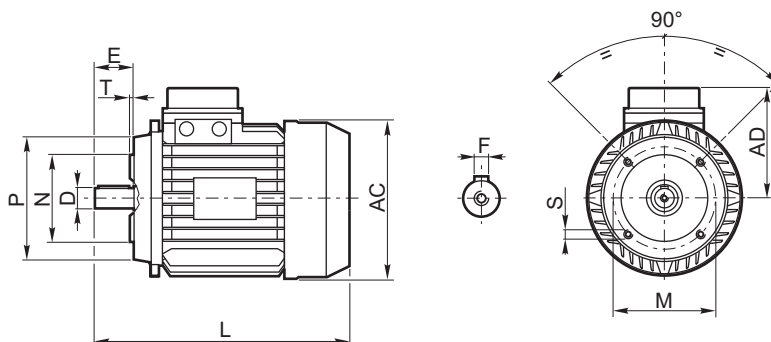

n°poli / poles n.						Grandezza Size	B5 - B14						B5					B14												
2	4	6					D	E	F	L	AD	AC	P	N	M	T	S	LA	P	N	M	T	S							
0.09	2.6	0.06	2.5	—	—	56	9	20	3	188	108	110	120	80	100	2.5	7	7	80	50	65	2.5	M5							
0.13	3.2	0.09	2.6	0.06	2.6		11	23	4	208	113	123	140	95	115	3	10	10	90	60	75	2.5	M5							
0.185	4.1	0.135	4	—	—	63	11	23	4	208	113	123	140	95	115	3	10	10	90	60	75	2.5	M5							
0.25	4.4	0.185	4.6	0.12	5		14	30	5	242	125	147	160	110	130	3	9	9.5	105	70	85	2.5	M6							
0.37	5.8	0.25	6	0.185	6.6	71	14	30	5	242	125	147	160	110	130	3	9	9.5	105	70	85	2.5	M6							
0.55	6.5	0.37	6.6	0.25	7.7		19	40	6	279	133	165	200	130	165	3.5	12	10.5	120	80	100	3	M6							
0.75	8.4	0.55	8	0.37	8.3	80	19	40	6	279	133	165	200	130	165	3.5	12	10.5	120	80	100	3	M6							
1.1	9.5	0.75	9.5	0.55	10		1.5	12.3	1.1	12.4	0.75	12	90S	24	50	8	305	148	181	200	130	165	3	11.5	11	140	95	115	3	M8
1.85	12.8	—	—	—	—	2.2	15	1.5	14.5	1.1	14.3	90L		24	50	8	330	148	181	200	130	165	3	11.5	11	140	95	115	3	M8
—	—	1.85	16.5	—	—	3	19.7	2.2	18.5	1.5	19		100	28	60	8	370	156	198	250	180	215	2.5	14	15	160	110	130	3.5	M8
4	24	3	21.4	—	—	5.5	31.6	4	31.3	2.2	30	112		28	60	8	388	173	222	250	180	215	2.5	14	11.5	160	110	130	3.5	M8
7.5	34.5	5.5	42	3	40	132S	—	—	7.5	52.5	4		46.4	132	38	80	10	460	189	264	300	230	265	4	14	15	200	130	165	4
—	—	9.2	56.5	5.5	52.5		—	—	11	79.2	7.5	78	160		—	—	—	500	189	264	300	230	265	4	14	15	200	130	165	4
11	52.5	11	79.2	7.5	78	160L	15	59	—	—	—	—		160L	42	110	12	610	235	317	350	250	300	5	18	15	250	180	215	5
18.5	98	15	97.5	11	110		—	—	—	—	—	—	—		180	48	110	14	654	235	317	350	250	300	5	18	15	250	180	215
—	—	18.5	154	15	140	—	—	—	—	—	—	—	180	48		110	14	710	248	320	350	250	300	5	19	17	—	—	—	—
—	—	22	160	—	—	—	—	—	—	—	—	—		—	—	—	—	—	—	—	—	—	—	—	—	—	—	—	—	—



Motore elettrico trifase autofrenante / Threephase electric motor with brake / Drehstrommotor
 Moteur électrique triphasé frein / Motor eléctrico trifásico autofrenante / motor eléctrico trifásico autofrenante

B5

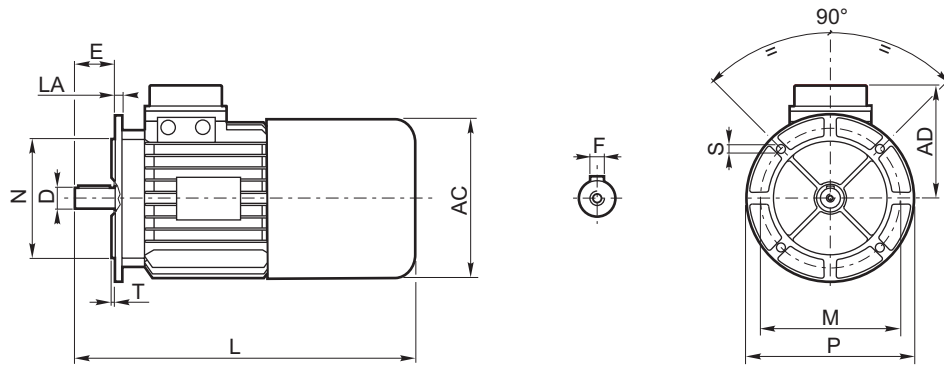

B14

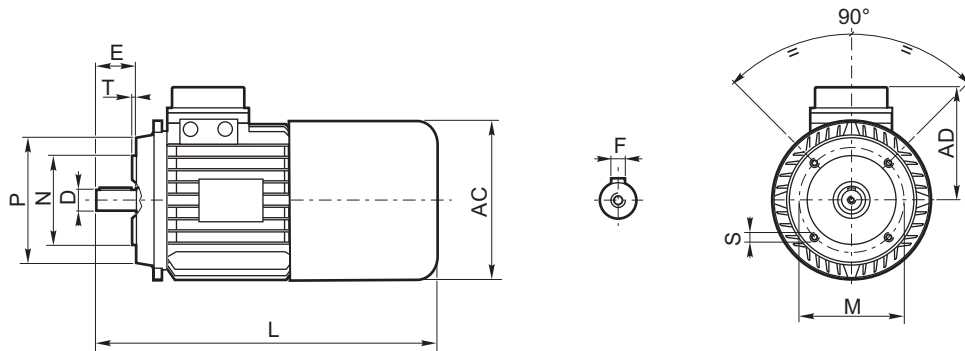

n°poli / poles n.						Grandezza Size	B5 - B14						B5					B14					
2		4		6			D	E	F	L	AD	AC	P	N	M	T	S	LA	P	N	M	T	S
kW	Kg	kW	Kg	kW	Kg																		
0.09	4.0	0.06	4.0	—	—	56	9	20	3	220	108	110	120	80	100	2.5	7	7	80	50	65	2.5	M5
0.13	5.0	0.09	5.0	0.06	3.0		11	23	4	256	113	123	140	95	115	3	10	10	90	60	75	2.5	M5
0.185	5.1	0.135	5	—	—	63	11	23	4	256	113	123	140	95	115	3	10	10	90	60	75	2.5	M5
0.25	5.4	0.185	5.7	0.12	6.5		14	30	5	286	125	147	160	110	130	3	9	9.5	105	70	85	2.5	M6
0.37	7.1	0.25	7.5	0.185	7.7	71	14	30	5	286	125	147	160	110	130	3	9	9.5	105	70	85	2.5	M6
0.55	7.8	0.37	8	0.25	9.2		19	40	6	332	133	165	200	130	165	3.5	12	10.5	120	80	100	3	M6
0.75	10.6	0.55	10.5	0.37	10.5	80	19	40	6	332	133	165	200	130	165	3.5	12	10.5	120	80	100	3	M6
1.1	11.7	0.75	12	0.55	12.2		24	50	8	357	148	181	200	130	165	3	11.5	11	140	95	115	3	M8
1.5	14.5	1.1	14.5	0.75	14	90S	24	50	8	357	148	181	200	130	165	3	11.5	11	140	95	115	3	M8
1.85	15	—	—	—	—		90L	24	50	8	382	148	181	200	130	165	3	11.5	11	140	95	115	3
2.2	17.3	1.5	16.9	1.1	16.7	100		28	60	8	442	156	198	250	180	215	2.5	14	15	160	110	130	3.5
3	23	2.2	21.5	1.5	22.5		112	28	60	8	447	171	222	250	180	215	2.5	14	11.5	160	110	130	3.5
4	27.5	3	24.9	—	—	132S		28	60	8	447	171	222	250	180	215	2.5	14	11.5	160	110	130	3.5
5.5	35.5	4	34.6	2.2	33.7		132	38	80	10	534	191	264	300	230	265	4	14	15	200	130	165	4
7.5	50	5.5	49.5	3	44.5	160		38	80	10	574	191	264	300	230	265	4	14	15	200	130	165	4
11	79	11	86.2	7.5	85		160L	42	110	12	770	235	317	350	250	300	5	18	15	250	180	215	5
15	93	—	—	—	—	180		42	110	12	805	235	317	350	250	300	5	18	15	250	180	215	5
22	120	—	—	—	—		180	48	110	14	870	235	352	350	250	300	5	19	17				
—	—	18.5	154	15	140																		
—	—	22	160	—	—																		



A series of horizontal yellow lines forming a writing area.



Condizioni generali di garanzia

La garanzia relativa a difetti di costruzione ha la durata di un anno dalla data di fatturazione della merce. Tale garanzia comporta per la VARMEC l'onere della sostituzione o riparazione delle parti difettose ma non ammette ulteriore addebiti per eventuali danni diretti o indiretti di qualsiasi natura. La garanzia decade nel caso in cui non siano state osservate le disposizioni riportate nel manuale di uso e manutenzione e/o siano state eseguite riparazioni o apportate modifiche senza nostro consenso scritto. La merce di ritorno sarà da noi accettata solo se spedita franco di ogni spesa.

Conditions générales de Garantie

La garantie concernant les défauts de construction dure un an à partir de la date de facturation de la marchandise. Varmec s'engage à substituer ou à réparer les parties défectueuses mais ne répondra pas des dommages direct ou indirects de n'importe quelle nature. VARMEC ne répondra non plus des réparations ou modifications apportées sans permission écrite de sa part. La marchandise de retour ne sera acceptée par Varmec qu'en case d'expédition port franc.

Warranty general conditions

Warranty for manufacturing defects will expire one-year the invoicing date. VARMEC will replace or repair defective parts but will not accept any further charges for direct or indirect damages of any kind. The warranty will become null and void if the instructions given in the use and maintenance manual are not complied with or if repairs or changes are carried out without our prior written authorization. Returned goods will be accepted only if delivered free of any charge.

Condiciones generales de garantía

La garantía relativa a defectos de construcción tiene una duración de un año de la fecha de facturación de la mercadería. Tal garantía comporta para VARMEC la obligación de sustituir o reparar la parte defectuosa pero no admite otros cargos por eventuales daños directos o indirectos de cualquier naturaleza. Queda fuera de toda garantía en el momento que no se hayan cumplido todas las instrucciones del manual de uso y mantenimiento o se haya hecho alguna reparación o modificación sin nuestro consentimiento escrito. La mercadería que se ha devuelta solo se aceptará enviada puerto franco.

Allgemeine garantiebdingungen

Die Garantie auf Herstellungsfehler dauert ein Jahr ab Rechnungsdatum der Ware. Aufgrund Garantie unterliegt der VARMEC die Pflicht der Ersetzung oder Reparatur der defekten Teile, jedoch nicht die Übernahme weiterer Belastungen für direkte oder indirekte Schäden egal welcher Natur. Die Garantie verfällt bei Nichtbeachtung der in der betreffenden "Betriebs- und Instandhaltungsanleitung" angeführten Anweisungen und/oder falls ohne unsere vorausgehende schriftliche Genehmigung Reparaturen oder Änderungen vorgenommen wurden. Die an uns zurückgesendete Ware akzeptieren wir nur wenn gebührenfrei geliefert.

Condições gerais de garantia

A garantia que cobre os defeitos de fabricação tem a validade de um ano a partir da data de faturamento da mercadoria. Esta garantia comporta para a VARMEC o ônus da substituição ou reparo das peças defeituosas, mas não inclui outras coberturas para eventuais danos diretos ou indiretos de qualquer natureza. A garantia perde a sua validade se não forem respeitadas as disposições indicadas no manual de uso e manutenção e/ou se forem feitos reparos ou realizadas modificações sem a nossa autorização por escrito. A mercadoria devolvida só será aceita por nós se os custos de expedição forem pagos pelo remetente.

RFV IT/EN/DE/FR/ES/PT P01W01

10/22

Questo catalogo annulla e sostituisce ogni precedente edizione o revisione. Tutti i dati elencati sono indicativi e s'intendono senza impegno alcuno da parte nostra. Ci riserviamo il diritto di apportare modifiche senza preavviso.

This catalogue cancels and replaces any previous edition or revision. All data listed is approximate and is not binding. We reserve the right to make changes without prior notice.

Dieser Katalog annulliert und ersetzt alle vorherigen Ausgaben oder Revisionen. Alle aufgeführten Daten sind Richtwerte und unverbindlich. Wir behalten uns das Recht vor, ohne vorherige Ankündigung Änderungen vorzunehmen.

Ce catalogue annule et remplace toute édition ou révision précédente. Toutes les informations énumérées sont indicatives et s'entendent sans aucune contrainte de notre part. Nous nous réservons le droit d'apporter toute modification sans préavis.

Este catálogo anula o sustituye cualquier edición o revisión precedente. Todos los datos indicados son orientativos y no vinculantes para nuestra empresa. Nos reservamos el derecho de aportar modificaciones sin previo aviso.

Este catálogo anula e substitui qualquer edição ou revisão anterior. Todos os dados apresentados são indicativos e não representam nenhum compromisso do fabricante. Reservamo-nos o direito de fazer alterações sem aviso prévio.



LA GAMMA PRODOTTI
PRODUCT RANGE

RCV **RIDUTTORI COASSIALI**
inline gearboxes

RFV **RIDUTTORI PENDOLARI**
shaft-mounted gearboxes

VAR **VARIATORI DI VELOCITÀ**
variable speed drives

VARMEC S.r.l.

Viale dell'Industria, 13
36016 Thiene (VI) Italy

Tel. 0445.368532
Fax 0445.370734

info@varmec.com

Italian
TECHNOLOGY



www.varmec.com