

GHA

GHA LINE CATALOGUE • CATALOGUE DE LA SÉRIE GHA • CATÁLOGO DE LA SERIE GHA



Pharmaceutical applications
Industrie chimique et pharmaceutique
Industria químico-farmacéutica



Marine applications
Applications en milieu marin
Aplicaciones marinas



Food applications
Industrie alimentare
Industria alimentaria

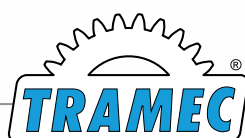



MADE IN ITALY

Para TRAMEC, la expresión "MADE IN ITALY" significa mucho más que lo que normalmente se piensa. Todos los productos de la empresa TRAMEC son el resultado de:

DISEÑO Y CREATIVIDAD ITALIANOS

Todos los productos TRAMEC han sido diseñados completamente en ITALIA, en la sede principal de CALDERARA di RENO (BO), en el corazón de la "MOTOR VALLEY" y de la "PACKAGING VALLEY", donde la mecánica es el pan de cada día. Es allí donde los ingenieros de TRAMEC expresan plenamente la creatividad típica ITALIANA, diseñando productos, también personalizados, y utilizando instrumentos cada vez más modernos.

PRODUCCIÓN Y MONTAJE

Todos los componentes principales del producto TRAMEC son el resultado de la red de producción de nuestra Empresa, que se basa en la experiencia y las capacidades de los artesanos de la zona.

Del montaje de estos componentes, completamente realizado por los técnicos de TRAMEC, que aplican sus capacidades con su experiencia y buen hacer, surge el REDUCTOR EPICICLOIDAL MTA.

SERVICIO DE ATENCIÓN AL CLIENTE

La importancia que TRAMEC otorga a sus clientes no solo se refleja en proporcionar un producto de alta calidad, sino también en garantizar una asistencia PRE y POST-VENTA al nivel del producto suministrado.

De esta manera, cuidando al máximo la calidad de los productos y permaneciendo constantemente junto al cliente, la cultura italiana de nuestra empresa se expresa plenamente.

Todo esto es lo que significa "MADE IN ITALY" para TRAMEC.

At TRAMEC "MADE IN ITALY" is an expression with a much deeper meaning, as all TRAMEC products are the result of:

ITALIAN DESIGN & CREATIVITY

TRAMEC is headquartered in CALDERARA DI RENO, BOLOGNA, in the heart of Italy's famous "MOTOR VALLEY" or "PACKAGING VALLEY" where the art of performance is mastered with the science of precision.

Italian design & engineering creativity is allowed via the most advanced tools by TRAMEC engineers in the design of our standard and customized products.

PRODUCTION & ASSEMBLY

The designs of TRAMEC are brought to life through the careful hands of machinists and technicians expressing the local tradition of excellence. All major components are produced, assembled, and inspected within the TRAMEC manufacturing organization.

From this long tradition, expressing performance and precision into objects of exceptional quality, we introduce the TRAMEC'S GEARBOXES.

CUSTOMER CARE

From conception to delivery, we at TRAMEC are focused upon our customers. Our passion is to bring to you the highest performing precision power transmission products, with a never ending commitment to quality and value. From the selection of a new power transmission element, through delivery of the component, to support after the sale, we are aiming to excellence. What we want to convey always is that everything we do is Made in Italy so to assure a complete experience of Italian culture and values.

From everyone at TRAMEC, this is what it means to say "MADE IN ITALY".

Pour TRAMEC, l'expression « MADE IN ITALY » a un sens beaucoup plus profond que ce que l'usage commun lui donne. Tous les produits TRAMEC sont le résultat:

DE LA CONCEPTION ET DE LA CRÉATIVITÉ ITALIENNE

Tous les produits TRAMEC sont entièrement conçus en ITALIE, auprès du siège principal de CALDERARA di RENO (BO), au cœur de la « MOTOR VALLEY » et de la « PACKAGING VALLEY » où la mécanique est à l'honneur. Ici, la créativité ITALIENNE est exprimée par les ingénieurs de TRAMEC, par la conception de produits, même personnalisés, et en utilisant des outils de plus en plus modernes.

PRODUCTION ET MONTAGE

Tous les principaux composants du produit TRAMEC sont le résultat du réseau de production de notre Entreprise qui s'appuie sur l'expérience et les compétences des artisans de la région.

L'assemblage de ces composants, entièrement réalisé par les techniciens TRAMEC qui, grâce à leur expérience et à leur savoir-faire, expriment leurs capacités, a donné naissance au RÉDUCTEUR ÉPICYCLOÏDAL MTA.

SERVICE CLIENTS

L'importance que TRAMEC attribue à ses clients se reflète non seulement dans la fourniture d'un produit de haute qualité, mais également dans la garantie d'une assistance AVANT et APRES -VENTE à la hauteur du produit fourni.

De cette manière, en veillant au maximum sur la qualité des produits et en restant constamment aux côtés du client, l'héritage et la culture Italienne de notre société sont pleinement exprimés.

Pour TRAMEC, tout cela signifie "MADE IN ITALY".



Qué es el tratamiento G.H.A. ® (*)

G.H.A.® es la más reciente innovación tecnológica que se puede aplicar a las superficies de todas las aleaciones a base de aluminio. Consiste en un tratamiento especial de oxidación anódica con espesor de 1 a 100 µm, tras el cual se realiza el sellado de las microporosidades con iones de plata (Ag+).

What is G.H.A. ® (*)

The G.H.A.® is the most recent and innovative technology applicable to the surface of all aluminum -base alloys. It consists of a special anodic oxidation treatment, with thickness ranging from 1 to 100 µm, followed by the sealing of the micro porosities through silver ions (Ag+).

Qu'est-ce que le traitement G.H.A.® (*)

Le sigle G.H.A.® désigne la technologie la plus récente et innovante applicable aux surfaces de tous les alliages à base d'aluminium. Il consiste en un traitement spécial d'oxydation anodique, d'une épaisseur de 1 à 100 µm, suivie d'une fermeture hermétique des micro-porosités par des ions d'argent (Ag+). L'Oxydation Anodique est, pour les

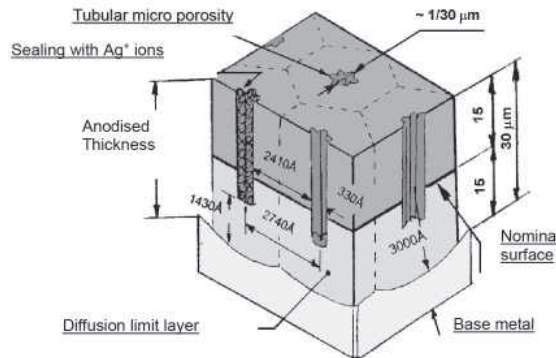

La Oxidación Anódica es, para las aleaciones con base de aluminio, el tratamiento de protección más ideal y seguro de todos los demás existentes, porque no se puede eliminar; de hecho, el aluminio de la base, durante el proceso galvánico, se transforma en óxido de aluminio (Al₂O₃), generando una capa de protección cerámica muy dura, resistente al calor (refractaria) y que no se puede eliminar. Los cristales de óxido de aluminio (Al₂O₃) tienen una estructura con aspecto de nido de abeja con cristales octaédricos, muy dura y compacta, con un orificio capilar en el centro de los octaedros que penetra casi hasta la base de estos.

The Anodic Oxidation of aluminum – base alloys is the most suitable and safe protection treatments because it's unremovable, in fact, during the galvanic process, the aluminum base is transformed into aluminum oxide (Al₂O₃), generating a very hard protective layer, similar to ceramic, which is heat resistant and not removable. Aluminum oxide crystals are disposed in a honeycomb structure, very hard and compact, with a capillary hole at the center of the octahedron and nearly reaching the base of them.

alloys à base d'aluminium, le traitement de protection le plus approprié et le plus sûr parmi tous les autres car il est inamovible ; en effet, l'aluminium de la base se transforme, au cours du processus de galvanisation, en oxyde d'aluminium (Al₂O₃), en générant une couche de protection de type céramique très dure, réfractaire à la chaleur et inamovible. Les cristaux de l'oxyde d'aluminium (Al₂O₃) ont une structure en nid d'abeille avec des cristaux octaédriques très dure et compacte, avec un trou capillaire au centre des octaédres qui pénètre presque jusqu'à la base de ces derniers.

Estos poros también albergan suciedad y microorganismos, por lo que las superficies anodizadas se manchan. Por ello, a menudo se recubren con sustancias de color que sellan los poros (negro o de otros colores). Los investigadores de la empresa SOUKEN de Kyoto han estudiado la posibilidad de sellar los poros de los cristales de los óxidos anódicos con un proceso galvánico especial que utiliza iones Ag+, transformando así lo que se consideraba como un defecto, la porosidad, en una ventaja, ya que estos servirán como pequeños depósitos para los iones Ag+, distribuyéndose de manera uniforme por la superficie y resultando permanentemente presentes cuando estos se están desgastando.

These pores are also a receptacle for dirt and microorganisms so that the anodized surfaces easily get stained. For this reason they are often treated with coloring substances to seal the pores (with black or other colors). The researchers of the company SOUKEN of Kyoto studied the possibility of sealing the crystal pores of the anodic oxides by a special galvanic process using Silver ions Ag+, thereby transforming what was considered a defect (the porosity) into an advantage. In fact, these pores provide a proper reservoir for Ag+ ions, thus being uniformly distributed on the surface and permanently present during the wear of the oxide layer. The G.H.A.® process (Golden Hard Anodizing) was then patented (Patent No. EP1207220). The high hardness of anodic oxide, HV 500-600, combined with the extraordinary properties of silver ions, see Table 1, gives to the treated surface biotechnological characteristics of great practical interest, see Table 2, ranging from the pharmaceutical and food industry to the technical and scientific fields.

Ces pores sont aussi un réceptacle pour la saleté et pour les micro-organismes, ce qui fait que les surfaces anodisées se tachent. C'est la raison pour laquelle elles sont souvent recouvertes de substances colorantes qui ferment les pores (noires ou d'autres couleurs). Les chercheurs de la société SOUKEN de Kyoto ont étudié la possibilité de fermer hermétiquement les pores des cristaux des oxydes anodiques, au moyen d'un processus spécial de galvanisation, en utilisant des ions Ag+, en transformant ainsi ce qui était considéré comme un défaut, la porosité, en une qualité car ils constituent de petits réservoirs pour les ions Ag+, résultant ainsi répartis de manière uniforme sur la surface et présents en permanence pendant l'usure.

El proceso G.H.A.® (Golden Hard Anodizing) ha sido patentado (Patente N.º EP1207220).

La elevada dureza del óxido anódico, HV 500-600, junto con las extraordinarias propiedades de los iones de plata, vea la tabla 1, dan características biotecnológicas a la superficie tratada, de altísimo interés en varias aplicaciones, vea la tabla 2, que van desde el ámbito farmacéutico y alimentario hasta llegar al técnico y al científico. Sin olvidar la elevada dureza y la refractariedad al calor, que son características propias de los óxidos anódicos.

Le processus G.H.A.® (« Golden Hard Anodizing », en français Anodisation dure dorée) a été breveté (Brevet N. EP1207220). La dureté élevée de l'oxyde anodique, HV 500-600, combinée aux propriétés extraordinaires des ions d'argent, cf. le tableau 1, donnent à la surface traitée des caractéristiques biotechnologiques d'un intérêt applicatif très important, cf. le tableau 2, qui vont du domaine pharmaceutique et alimentaire au domaine technique et scientifique. Sans oublier la longue durée et le caractère réfractaire à la chaleur qui sont autant de caractéristiques propres aux oxydes anodiques.

Tab. 1

PROPIEDADES DEL TRATAMIENTO G.H.A.®	PROPERTY OF G.H.A.® TREATMENT	PROPRIÉTÉS DU TRAITEMENT G.H.A.®
Elevada capacidad antibacteriana y antimoho (bactericida)	<i>High antibacterial capacity and anti-mold (Antibacterial)</i>	Haute capacité antibactérienne et anti-moisissure (Bactéricide)
Resistencia a la corrosión	<i>Corrosion resistance</i>	Résistance à la corrosion
Bajo coeficiente de fricción, autolubricación y resistencia al desgaste	<i>Low coefficient of friction, self-lubrication and wear resistance.</i>	Faible coefficient de frottement, auto-lubrification et résistance à l'usure
Elevada capacidad antiestática	<i>High antistatic capacity</i>	Grande capacité antistatique
Capacidad de absorber el calor y de disiparlo con ondas de rayos infrarrojos	<i>Ability to absorb heat and dissipate it as ultra-infrared waves</i>	Capacité d'absorber la chaleur et de la dissiper avec des ondes infrarouges
Elevada conductividad térmica y alto rendimiento termodinámico	<i>High thermal conductivity and high thermodynamic efficiency</i>	Haute conductivité thermique et haute efficacité thermodynamique

CARACTERÍSTICAS BIOTECNOLÓGICAS (*) BIOTECHNOLOGY FEATURES (*) CARACTÉRISTIQUES BIOTECHNOLOGIQUES (*)						
Material Material Matériau	Dureza HV Hardness HV Dureté HV	Temperatura de fusión Melting temperature Température de fusion	Coefficiente de fricción Coefficient of friction Coefficient de frottement	Capacidad bacteriostática Bacteriostatic capacity Capacité bactériostatique	Resistencia a la corrosión SST Corrosion resistance SST Résistance à la corrosion SST	Resistencia al desgaste Resistance to consumption Résistance à l'usure
Aleación de aluminio <i>Aluminum Alloy</i> Alliage d'aluminium	70÷100	680°C	0,44	ninguna <i>none</i> aucune	100 h	1000 h
Óxido de aluminio con tratamiento G.H.A.® <i>Aluminum oxide with G.H.A.® treatment</i> Oxyde d'aluminium avec traitement G.H.A.®	500÷550	2100°C	0,025	muy elevada <i>high</i> très élevée	10.000 h	1.000.000 h
Oxidación dura <i>Hard oxidizing</i> Oxydation dure	500÷550	2100°C	0,15	ninguna <i>none</i> aucune	200 ÷ 500 h	1.000 h

Por lo tanto, el recubrimiento G.H.A. en combinación con una aleación ligera apropiada (en este caso, el aluminio) puede ser considerado por los diseñadores como un nuevo material y una alternativa válida a materiales costosos, como aleaciones de titanio o aceros inoxidables, o a aceros con revestimientos nobles y costosos, como TIN, PVD, CVD, cromo duro, níquel químico, níquel teflón, etc.

(*): Extraído del documento «Evaluación del Efecto Bactericida en Tratamiento G.H.A. (a cargo del centro de análisis y pruebas de G.H.A. Europe)»

Not to mention the high hardness and refractory heat factor that are typical of the anodic oxides.

Therefore the G.H.A. coating, if combined with the appropriate aluminum alloy, can be considered by the designers as a real new material and can be a good alternative to expensive metals such as titanium alloys, stainless steel or steel treated by expensive and well known coatings like TIN – PVD – CVD – Hard chromium – Chemical Nickel – Nickel – Teflon etc.

(*): Taken from the document "Valutazione Effetto Battericida su Trattamento G.H.A. (a cura del centro servizi analisi e prove di G.H.A. Europe)"

Par conséquent, le G.H.A. en combinaison avec un alliage léger approprié (dans notre cas, l'aluminium), peut être considéré, par une partie des concepteurs, comme un véritable nouveau matériau et peut représenter une alternative valable aux matériaux coûteux tels que les alliages de titane ou les aciers inoxydables ou aux aciers revêtus de revêtements coûteux et reconnus comme le TIN - PVD - CVD - chrome dur - nickel chimique - nickel-téflon, etc.

(*) : Extrait du document « Évaluation de l'Effet Bactéricide sur le Traitement G.H.A (édité par le centre des services d'analyses et de tests de G.H.A. Europe) »

Entre las muchas propiedades del tratamiento G.H.A. destacan las antibacterianas y anticorrosivas, lo que hace que el tratamiento sea especialmente adecuado para aplicaciones en ambientes agresivos o donde se requiera un alto nivel de seguridad frente a posibles contaminaciones bacterianas.

Propiedades antibacterianas

La norma técnica internacional ISO 22196:2011, que a su vez se basa en el procedimiento JIS Z 2801:2010, establece directrices sobre métodos de análisis, materiales y criterios de evaluación de la actividad antibacteriana, constituyendo un criterio unívoco y una norma para los análisis.

La eficacia bactericida del tratamiento G.H.A. ha sido declarada **de acuerdo con la norma ISO 22196:2011.**

El aluminio tratado con G.H.A. ha reducido al menos 1000 veces el crecimiento microbiológico en comparación con el mismo aluminio sin tratamiento G.H.A.

Resistencia a la corrosión

• En conformidad con la norma UNI EN ISO 9227:2017, se han realizado pruebas de corrosión en una cámara de niebla salina neutra (NSS), que han dado resultados positivos, midiendo una duración superior a 2016 horas de exposición, en el caso del tratamiento G.H.A. combinado con una aleación de aluminio específica.

• Según la norma ISO 4628-1:2003 y mediante análisis espectrofotométrico se han efectuado pruebas para evaluar la intensidad del cambio de las superficies de aluminio tratado con G.H.A. en contacto con soluciones de detergentes o desinfectantes profesionales, proporcionando información sobre la compatibilidad y las contraindicaciones en base al principio activo.

Además de las pruebas efectuadas por la empresa G.H.A. Europe S.r.L., TRAMEC ha realizado numerosas pruebas en laboratorios independientes y acreditados, recurriendo al asesoramiento de empresas de investigación especializadas. Los organismos participantes han sido los siguientes:

• **Cepra Srl** - Via del Tintoretto 6/2 - 40033 Casalecchio di Reno (BO) - Italia - NIF y N.º de IVA 02002271209 - acreditado ACCREDIA n.º 1679L - CON CERTIFICACIÓN ISO 9001 e ISO/IEC 17025:2005

• **Tecnal Srl** - Via Castelfranco 17/D - Loc. Bazzano 40053 Valsamoggia (BO) - NIF 02460570373 - N.º de IVA 00579881202 - acreditado ACCREDIA n.º 0299 - en conformidad con la norma UNI CEI EN ISO/IEC 17025:2005

• **Gelt International Srl** - Via A. Costa 228 - 40134 Bologna - N.º de IVA/ NIF 03650351202

Among the many advantages of the G.H.A. treatment, there are the antibacterial and anticorrosive properties that make the treatment particularly suitable for applications in harsh environments or where a high level of safety is required against possible bacterial contamination.

Antibacterial properties

The international technical standard ISO 22196:2011, which in turn is based on the JIS Z 2801:2010 procedure, sets guidelines on the analysis methods, materials and evaluation criteria for antibacterial activity, constituting a univocal criterion and a standard for analysis.

The bactericidal efficacy of the G.H.A. treatment was declared in accordance with ISO 22196: 2011.

Aluminium treated with G.H.A. has discouraged microbiological growth by at least 1000 times compared to the same aluminium not treated with G.H.A..

Corrosion resistance

• *In compliance with UNI EN ISO 9227:2017, corrosion tests were carried out in a neutral salt spray (NSS) chamber which gave positive results, measuring over 2016 hours of exposure, in the case of G.H.A. combined with a specific aluminium alloy.*

• *According to ISO 4628-1:2003 and by means of spectrophotometric analysis, tests have been conducted to assess the intensity of the change of aluminium surfaces treated with G.H.A. in contact with detergent and/or disinfectant or professional sanitising solutions, providing information on compatibility and contraindications based on the active ingredient.*

In addition to the tests carried out by G.H.A. Europe S.r.L., TRAMEC has conducted numerous tests at independent and accredited laboratories, working with specialised research companies. The bodies involved were the following:

• **Cepra Srl** - Via del Tintoretto 6/2 - 40033 Casalecchio di Reno (BO) - Italy - Tax Code and VAT no. 02002271209 - ACCREDIA accreditation no. 1679L - ISO 9001 and ISO/IEC 17025:2005 CERTIFIED

• **Tecnal Srl** - Via Castelfranco 17/D - Loc. Bazzano 40053 Valsamoggia (BO) - Tax Code 02460570373 - VAT no. 00579881202 - ACCREDIA accreditation no. 0299 - in compliance with standard UNI CEI EN ISO/IEC 17025:2005

• **Gelt International Srl** - Via A. Costa 228 - 40134 Bologna - VAT no./ Tax Code 03650351202

Parmi les nombreuses propriétés du traitement G.H.A., ce sont ses propriétés antibactériennes et anticorrosion, qui rendent le traitement particulièrement adapté aux applications dans des environnements agressifs ou dans lesquels un haut niveau de sécurité est requis contre une éventuelle contamination bactérienne, qui se démarquent.

Propriétés antibactériennes

La norme technique internationale ISO 22196: 2011, basée à son tour sur la procédure JIS Z 2801: 2010, définit des lignes directrices relatives aux méthodes d'analyse, matériaux et critères d'évaluation de l'activité antibactérienne, constituant un critère univoque et un standard pour les analyses.

L'efficacité bactérienne du traitement G.H.A. a été décrétée **conformément à la norme ISO 22196:2011.**

L'aluminium traité G.H.A. a ralenti la croissance microbiologique d'au moins 1000 fois par rapport au même aluminium non traité G.H.A.

Résistance à la corrosion

• Conformément à la norme UNI EN ISO 9227: 2017, ont été effectués des essais de corrosion dans une chambre de brouillard salin neutre (NSS) qui ont donné des résultats positifs, avec une durée supérieure à 2016 heures d'exposition, dans le cas du traitement G.H.A. combiné avec un alliage d'aluminium spécifique.

• Conformément à la norme ISO 4628-1: 2003 et en effectuant des analyses spectrophotométriques, des tests ont été menés pour évaluer l'intensité du changement des surfaces en aluminium traité G.H.A. en contact avec des solutions de détergents et/ou désinfectants professionnels, fournissant des informations sur la compatibilité et les contre-indications en fonction du principe actif.

Outre les tests effectués par la société G.H.A. Europe S.R.L., TRAMEC a effectué de nombreux tests dans des laboratoires indépendants et accrédités, en s'appuyant sur les conseils de sociétés de recherche spécialisées. Les organismes impliqués étaient les suivants :

• **Cepra Srl** - Via del Tintoretto 6/2 - 40033 Casalecchio di Reno (BO) - Italy - Code fiscal et N.º d'identification à la T.V.A. 02002271209 - accréditation ACCREDIA n.º 1679L - CERTIFIÉE ISO 9001 et ISO/IEC 17025:2005

• **Tecnal Srl** - Via Castelfranco 17/D - Loc. Bazzano 40053 Valsamoggia (BO) - Code fiscal 02460570373 - N.º d'identification à la T.V.A. 00579881202 - accréditation ACCREDIA n.º 0299 - conforme à la norme UNI CEI EN ISO/IEC 17025:2005

• **Gelt International Srl** - Via A. Costa 228 - 40134 Bologna - N.º d'identification à la T.V.A. / code fiscal 03650351202

• **Kiwa Cermet Italia S.p.A.** - Via Cadriano, 23 - 40057 - Granarolo dell'Emilia (BO) - N.º de IVA 00627711203 - NIF 03502820370 - Código SDI: SN4CSRI - acreditado ACCREDIA n.º 0001 - en conformidad con la norma UNI CEI EN ISO/IEC 17025:2005

• **Kiwa Cermet Italia S.p.A.** - Via Cadriano, 23 - 40057 - Granarolo dell'Emilia (BO) - VAT no. 00627711203 - Tax Code 03502820370 - SDI Code: SN4CSRI - ACCREDIA accreditation no. 0001 - in compliance with standard UNI CEI EN ISO/IEC 17025:2005

• **Kiwa Cermet Italia S.p.A.** - Via Cadriano, 23 - 40057 - Granarolo dell'Emilia (BO) - N.º d'identification à la T.V.A. 00627711203 - Code fiscal 03502820370 - Code SDI : SN4CSRI - accréditation ACCREDIA n.º 0001 - conforme à la norme UNI CEI EN ISO/IEC 17025:2005

Las pruebas efectuadas por G.H.A. Europe S.r.L. se han efectuadas en el Laboratorio:

• **3A Laboratori srl** - Via A. Volta, 1/d 35020 Maserà di Padova (PD) - ITALIA
NIF y N.º de IVA 04296730288 Registro Mercantil de Padua - R.E.A. n.º 378402/PD Acreditamiento ACCREDIA n.º 1165, conformidad UNI CEI EN ISO/IEC 17025:2005

The tests conducted by G.H.A. Europe S.r.L. were performed by the following Laboratory:

• **3A Laboratori srl** - Via A. Volta, 1/d 35020 Maserà di Padova (PD) - ITALY
Tax Code and VAT no. 04296730288 Padova Business Register - R.E.A. no. 378402/PD ACCREDIA accreditation no. 1165, in compliance with UNI CEI EN ISO/IEC 17025:2005

Les tests menés par G.H.A. Europe S.r.L. ont été effectués par le Laboratoire :

• **3A Laboratori srl** - Via A. Volta, 1/d 35020 Maserà di Padova (PD) - ITALY
Code fiscal et n.º d'identification à la T.V.A. 04296730288 Registre des Entreprises de Padoue - R.E.A. n.º 378402/PD Accréditation ACCREDIA n.º 1165, conformité UNI CEI EN ISO/IEC 17025:2005

Patente TRAMEC

“REDUCTOR MECÁNICO TRATADO CON IONES DE PLATA”

TRAMEC ha depositado su patente (n.º de patente EP18183494.6) para proteger la propiedad intelectual sobre el reductor denominado «GHA». El uso de la plata y/o de los iones de plata aplicado a un reductor, de cualquier forma, está protegido legalmente por las leyes en vigor y TRAMEC posee todos sus derechos

El uso de la plata y/o de los iones de plata aplicado a un reductor, de cualquier forma, está protegido legalmente por las leyes en vigor y TRAMEC posee todos sus derechos.

Estos derechos, si es necesario, los podrá reclamar TRAMEC en los lugares y momentos previstos.

La patente de invención ha sido registrada por:

BUGNION S.p.A. - Intellectual Property
Departamento de Patentes - Oficina de Bolonia
Via di Corticella, 87 - Bolonia (BO) ITALIA

Patent TRAMEC

“MECHANICAL GEARBOX TREATED WITH SILVER IONS”

TRAMEC deposited its own patent (patent N. EP18183494.6) to protect the intellectual property connected with the gearbox named “GHA”.

The use of silver and / or silver ions applied to a gearbox in any form is legally protected by the laws in force . All rights reserved by TRAMEC.

TRAMEC will make use of these rights, if necessary, in the venues and places provided by law.

The patent filing has been cared for by :

BUGNION S.p.A. - Intellectual Property
Patent Department - Office of Bologna
Via di Corticella, 87 - Bologna (BO) ITALY

Brevet TRAMEC

« RÉDUCTEUR MÉCANIQUE TRAITÉ AUX IONS D'ARGENT »

La Société TRAMEC a déposé son brevet (brevet N. EP18183494.6) afin de protéger sa propriété intellectuelle liée au réducteur appelé « GHA ». **L'utilisation de l'argent et/ou des ions d'argent appliquée à un réducteur, sous toute forme, est protégée légalement par les lois en vigueur et TRAMEC en détient tous les droits.**

Le cas échéant, ces droits seront revendiqués par la société TRAMEC dans la juridiction et les lieux prévus.

Le dépôt du brevet d'invention a été effectué par :

BUGNION S.p.A. - Intellectual Property
Département Brevets - Bureau de Bologne
Via di Corticella, 87 - Bologna (BO) ITALY

1.0	INFORMACIÓN GENERAL	GENERAL INFORMATION	GÉNÉRALITÉS	8
1.1	Unidad de medida	<i>Measurement units</i>	Unités de mesure	12
1.2	Factor de servicio	<i>Service factor</i>	Facteur de service	12
1.3	Selección	<i>Selection</i>	Sélection	14
1.4	Cargas radiales y axiales	<i>Radial and axial loads</i>	Charges radiales et axiales	15
1.5	Potencia térmica	<i>Thermal power</i>	Puissance thermique	16
1.6	Lubricación	<i>Lubrication</i>	Lubrification	17
1.7	Instalación	<i>Installation</i>	Installation	17
1.8	Rodaje	<i>Running-in</i>	Rodage	18
1.9	Mantenimiento	<i>Maintenance</i>	Entretien	18
1.10	Operaciones de lavado	<i>Washing operations</i>	Opérations de lavage	19

GHA - PREMIUM

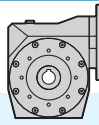

2.0	REDUCTORES DE TORNILLO SIN FIN GHA	GHA WORM GEARBOXES	RÉDUCTEURS À VIS SANS FIN GHA	21
-----	------------------------------------	--------------------	-------------------------------	----

GHA - CLASSIC

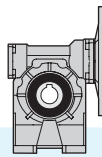

3.0	REDUCTORES DE TORNILLO SIN FIN GK	GK WORM GEARBOXES	RÉDUCTEURS À VIS SANS FIN GK	39
-----	-----------------------------------	-------------------	------------------------------	----

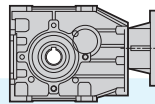

4.0	REDUCTORES CON EJES ORTOGONALES GT	BEVEL HELICAL GEARBOX GT	RÉDUCTEURS À AXES ORTHOGONAUX GT	59
-----	------------------------------------	--------------------------	----------------------------------	----

GHA - MODULAR

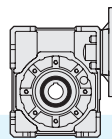

5.0	REDUCTORES DE TORNILLO SIN FIN GX	GX WORM GEARBOXES	RÉDUCTEURS À VIS SANS FIN GX	77
-----	-----------------------------------	-------------------	------------------------------	----



6.0	MOTORES MHA PREMIUM	MHA PREMIUM MOTORS	MOTEURS MHA PREMIUM	97
-----	---------------------	--------------------	---------------------	----

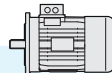

7.0	MOTORES GHA CLASSIC	GHA CLASSIC MOTORS	MOTEURS GHA CLASSIC	101
-----	---------------------	--------------------	---------------------	-----

8.0	CONDICIONES GENERALES DE VENTA	TERM AND CONDITIONS OF SALE	CONDITIONS GÉNÉRALES DE VENTE	105
-----	--------------------------------	-----------------------------	-------------------------------	-----

GHA - PREMIUM

Reductores de tornillo sin fin con carcasa de aleación de aluminio, adecuadamente seleccionada para crear una capa gruesa de tratamiento G.H.A., disponibles desde el tamaño 30 al 75.

Los reductores de la serie PREMIUM tienen excelentes propiedades antibacterianas y de resistencia a la corrosión (duración superior a 2016 horas de exposición en la cámara de niebla salina neutra NSS) garantizadas por el elevado espesor del tratamiento G.H.A.

El perfil exterior liso especial de la carcasa minimiza la acumulación de suciedad, permite una excelente limpieza y facilita las operaciones de enjuague, gracias a la geometría de las tapas que se extienden hasta unas pocas décimas de mm con respecto al eje hueco, para proteger las juntas.

Probado en laboratorio para comprobar la compatibilidad y las contraindicaciones en base a diferentes principios activos de las soluciones de detergentes o desinfectantes profesionales. Para obtener más información, consulte la sección dedicada a las operaciones de higienización.

Por sus características únicas, los reductores de la serie PREMIUM son la solución ideal para una amplia gama de aplicaciones en ambientes sensibles, en los sectores de la industria ALIMENTARIA, FARMACÉUTICA y MARÍTIMA.

Worm gearboxes with aluminum alloy casing subjected to enhanced GHA treatment, available from size 30 to 75.

PREMIUM series gearboxes have excellent antibacterial and corrosion resistance properties (over 2016 hours in NSS salt spray tests) guaranteed by the high thickness of the G.H.A .. treatment.

Furthermore, the special smooth external profile of the gearbox body has been specially designed to allow for maximum cleanliness, having lab-tested the resistance to standard detergents (see the product cleaning section).

Tested in the laboratory in order to verify the compatibility and contraindications on the basis of several active ingredients of detergents and/or disinfectants or professional sanitising solutions. For further information, please refer to the section dedicated to sanitation operations.

Thanks to their unique characteristics, the PREMIUM series gearboxes are the ideal solution for a wide range of applications in sensitive environments in the FOOD, PHARMACEUTICAL and MARINE sectors.

Réducteurs à vis sans fin avec carcasse en alliage d'aluminium opportunément sélectionné pour créer une couche épaisse de traitement G.H.A., disponibles de la taille 30 à 75.

Les réducteurs de la série PREMIUM possèdent d'excellentes propriétés antibactériennes et de résistance à la corrosion (plus de 2016 heures d'exposition dans une chambre de brouillard salin neutre NSS), garanties par l'épaisseur élevée du traitement G.H.A.

Le profil extérieur lisse spécial de la carcasse minimise le dépôt de saleté, permet un nettoyage optimal et facilite les opérations de rinçage, grâce à la géométrie des couvercles s'étendant jusqu'à quelques dixièmes de mm de l'arbre creux, protégeant ainsi les joints.

Testé en laboratoire pour vérifier la compatibilité et les contre-indications selon les différents principes actifs des solutions de détergents et/ou de désinfectants professionnels. Pour plus d'informations, consulter le chapitre consacré aux opérations de désinfection.

En raison de leurs caractéristiques uniques, les réducteurs de la série PREMIUM constituent la solution idéale pour une large gamme d'applications dans des environnements sensibles des secteurs ALIMENTAIRE, PHARMACEUTIQUE et MARIN.

GHA - PREMIUM

CERTIFICADO DE CONFORMIDAD CON LOS REQUISITOS DE LA DIRECTIVA 2006/42/CE ANEXO I CAP. 2.1

El organismo KIWA CERMET ITALIA S.p.A. ha llevado a cabo las actividades de inspección según la norma ISO/IEC 17020 y ha certificado que los «Reductores para máquinas alimentarias de aluminio con tratamiento de iones de plata GHA (tipo: GHA 30-4050-63-75) cumplen con la Directiva 2006/42/CE, anexo I, capítulo 2.1 - Máquinas alimentarias y máquinas para productos cosméticos o farmacéuticos».

CERTIFICADO HACCP INTERNATIONAL EN AUSTRALASIA

HACCP International es un reconocido organismo de certificación especializado en la certificación de equipos, productos y servicios utilizados en la industria alimentaria (metodología HACCP).

Tonson Australia, nuestro distribuidor en Australasia, ha obtenido, con respecto a su territorio, el certificado HACCP International para reductores GHA PREMIUM. Los reductores GHA PREMIUM están certificados (en Australasia) como adecuados para utilizarse en plantas de producción y manipulación de alimentos que operan de acuerdo con un programa de seguridad alimentaria basado en las normas HACCP.

A pesar de que los reductores de la serie Premium están certificados como dispositivos adecuados para utilizarse en máquinas alimentarias y, por lo tanto, para aplicaciones en plantas de producción y manipulación de alimentos, **no están certificados para utilizarse en contacto con alimentos.**

CERTIFICATE OF COMPLIANCE WITH THE REQUIREMENTS OF DIRECTIVE 2006/42/EC ANNEX I CHAP. 2.1

KIWA CERMET ITALIA S.p.A. carried out the inspection activities in accordance with standard ISO/IEC 17020, certifying that the "Food processing machinery reducers made of aluminium with GHA silver ion treatment (type: GHA 30-4050-63-75) comply with Directive 2006/42/EC, Annex I chapter 2.1 - Foodstuffs machinery and machinery for cosmetics or pharmaceutical products"

HACCP INTERNATIONAL CERTIFICATE IN AUSTRALASIA

HACCP International is a renowned certification body, specialised in the certification of equipment, products and services used in the food industry (HACCP Methodology).

Tonson Australia, our distributor in Australasia, has obtained, for its reference area, the HACCP International certificate for GHA PREMIUM reducers. GHA PREMIUM reducers are certified (in Australasia) as suitable for use in food production and handling plants operating according to a food safety programme based on HACCP standards.

Although the Premium series reducers are certified as suitable devices for use on food processing machines and therefore for applications that operate in food production and handling plants, they are not certified for use in contact with food.

CERTIFICAT DE CONFORMITÉ AUX PRESCRIPTIONS DE LA DIRECTIVE 2006/42/CE ANNEXE I CHAP. 2.1

L'organisme KIWA CERMET ITALIA S.p.A. a mené les activités d'inspection conformément à la norme ISO/IEC 17020 en certifiant que les « Réducteurs pour machines alimentaires en aluminium avec traitement GHA aux ions d'argent (type : GHA 30-4050-63-75) sont conformes à la Directive 2006/42/CE, Annexe I chapitre 2.1 - Machines alimentaires et machines pour produits cosmétiques ou pharmaceutiques ».

CERTIFICAT INTERNATIONAL HACCP EN AUSTRALASIE

HACCP International est un organisme de certification renommé, spécialisé dans la certification des équipements, produits et services utilisés dans l'industrie alimentaire (Méthode HACCP).

Tonson Australia, notre distributeur en Australasie, a obtenu, en référence à son territoire, le certificat international HACCP pour les réducteurs GHA PREMIUM. Les réducteurs GHA PREMIUM sont certifiés (en Australasie) comme étant appropriés pour une utilisation dans les usines de production et de manipulation d'aliments qui opèrent selon un programme de sécurité alimentaire basé sur les normes HACCP.

Bien que les réducteurs de la série PREMIUM soient certifiés en tant que dispositifs adaptés à l'utilisation sur des machines alimentaires et donc pour des applications qui opèrent dans des usines de production et de manipulation des aliments, **ils ne sont pas certifiés pour l'utilisation au contact des aliments.**

GHA



GHA - CLASSIC

Forman parte de este grupo los reductores de tornillo sin fin serie GK, disponibles en los tamaños del 30 al 89, y los reductores con ejes ortogonales de la serie GT, disponibles desde el tamaño 56 al 75.

Las carcasas tienen el mismo perfil exterior que los reductores TRAMEC estándar (no GHA).

Equipados con carcasa de aleación de aluminio fundido a presión en la que se ha aplicado el tratamiento GHA estándar, los reductores de la serie CLASSIC tienen las mismas características antibacterianas de la serie PREMIUM y resistencia a la corrosión estándar (250 horas en pruebas de niebla salina NSS).

CERTIFICADO HACCP INTERNACIONAL EN AUSTRALASIA

Tonson Australia, nuestro distribuidor en Australasia, ha obtenido, con respecto a su territorio, **el certificado HACCP Internacional para reductores GHA CLASSIC.**

Las gamas de productos GKC y GTF están certificadas (en Australasia) como adecuadas para utilizarse en plantas de producción y manipulación de alimentos que operan de acuerdo con un programa de seguridad alimentaria basado en las normas HACCP.

Gracias a sus características únicas, los reductores de la serie GHA CLASSIC son especialmente idóneos para las aplicaciones en la industria alimentaria, farmacéutica y marítima.

A pesar de que los reductores de la serie CLASSIC están certificados como dispositivos adecuados para utilizarse en máquinas alimentarias y, por lo tanto, para aplicaciones en plantas de producción y manipulación de alimentos, **no están certificados para utilizarse en contacto con alimentos.**

This group includes GK series worm gearboxes, available from size 30 to 89, and the GT series bevel helical gearboxes, available from size 56 to 75.

The casings have the same external profile as the standard TRAMEC gearboxes (non-GHA) and are HACCP certified for food applications.

Fitted with a die cast aluminum alloy casing on which the standard GHA treatment is applied, the CLASSIC series gearboxes have the same very high antibacterial properties as the PREMIUM series and standard corrosion resistance (250 hours in NSS salt spray tests).

HACCP INTERNATIONAL CERTIFICATE IN AUSTRALASIA

Tonson Australia, our distributor in Australasia, has obtained, for its reference area, the HACCP International certificate for GHA CLASSIC reducers.

The GKC and GTF product ranges are certified (in Australasia) as suitable for use in food production and handling plants operating according to a food safety programme based on HACCP standards.

Thanks to their unique characteristics, the GHA CLASSIC series reducers are particularly suitable for applications in food, pharmaceutical and marine sectors.

Although the CLASSIC series reducers are certified as suitable devices for use on food processing machines and therefore for applications that operate in food production and handling plants, they are not certified for use in contact with food.

Appartiennent à ce groupe les réducteurs à vis sans fin de la série GK, disponibles de la taille 30 à 89 et les réducteurs à axes orthogonaux de la série GT, disponibles de la taille 56 à 75.

Les carcasses ont le même profil extérieur que les réducteurs TRAMEC standards (non GHA).

Dotés d'une carcasse en alliage d'aluminium moulé sous pression sur laquelle est appliqué le traitement GHA standard, les réducteurs de la série CLASSIC présentent les mêmes propriétés antibactériennes que la série PREMIUM et une résistance à la corrosion standard (250 heures en test de brouillard salin NSS).

CERTIFICAT INTERNATIONAL HACCP EN AUSTRALASIE

Tonson Australia, notre distributeur en Australasia, a obtenu, en référence à son territoire, **le certificat international HACCP pour les réducteurs GHA CLASSIC.**

Les gammes de produits GKC et GTF sont certifiées (en Australasia) comme étant adaptées à une utilisation dans des usines de production et de manipulation des aliments qui opèrent selon un programme de sécurité alimentaire basé sur les normes HACCP.

En raison de leurs caractéristiques uniques, les réducteurs de la série GHA CLASSIC conviennent tout particulièrement aux applications dans le domaine alimentaire, pharmaceutique et marin.

Bien que les réducteurs de la série CLASSIC soient certifiés en tant que dispositifs adaptés à l'utilisation sur des machines alimentaires et donc pour des applications qui opèrent dans des usines de production et de manipulation des aliments, **ils ne sont pas certifiés pour l'utilisation au contact des aliments.**

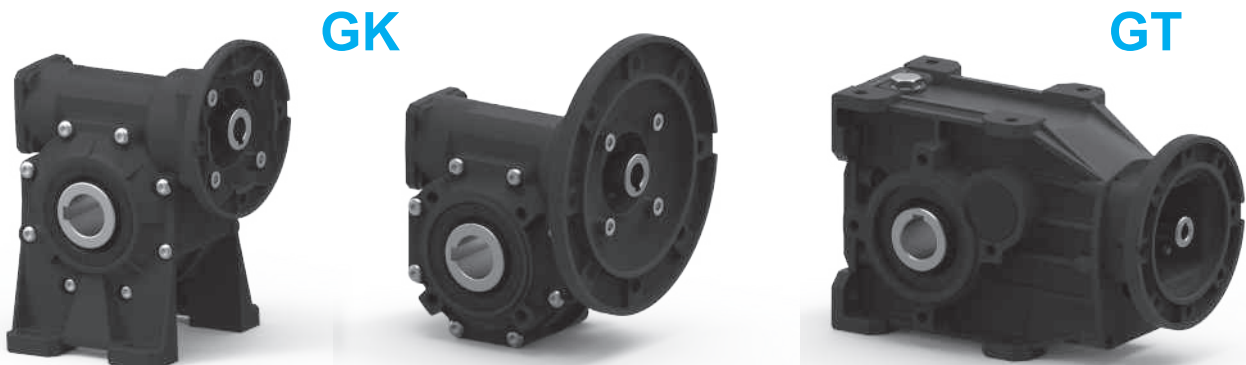

GHA - MODULAR

Reductores de tornillo sin fin serie GX, disponibles desde el tamaño 30 al 89.

Equipados con carcasa de aleación de aluminio fundido a presión en la que se ha aplicado el tratamiento G.H.A. estándar, los reductores de la serie MODULAR tienen las mismas elevadas características antibacterianas de la serie PREMIUM y resistencia a la corrosión estándar (250 horas en pruebas de niebla salina NSS).

El perfil externo de la carcasa es el del reductor estándar (no GHA). Con respecto a las otras series, la serie GHA MODULAR es más versátil, gracias al cuerpo monolítico caracterizado por una alta modularidad de fijación debido a las elaboraciones en tolerancia de todas las superficies de apoyo. Por otro lado, la carcasa es más difícil de limpiar y los reductores de esta serie no cuentan con certificación HACCP, por lo que se recomienda su uso en ambientes alimentarios secos.

GX series worm gearboxes, available from size 30 to 89.

Fitted with a die cast aluminum alloy casing on which the standard G.H.A. treatment is applied, the MODULAR series gearboxes have the same very high antibacterial properties as the PREMIUM series and standard corrosion resistance (250 hours in NSS salt spray tests).

The external profile of the casing is that of the standard reducer (non-GHA). Compared to the other series, the GHA MODULAR series offers more versatility thanks to the monolithic body featuring high fastening modularity due to the machining tolerance of all support surfaces. On the other hand, the casing is more difficult to clean and the reducers of this series are not HACCP certified, which is why they are recommended for use in dry food environments.

Réducteurs à vis sans fin de la série GX, disponibles de la taille 30 à 89.

Dotés d'une carcasse en alliage d'aluminium moulé sous pression sur laquelle est appliqué le traitement G.H.A. standard, les réducteurs de la série MODULAR présentent les mêmes très hautes propriétés antibactériennes que la série PREMIUM et une résistance à la corrosion standard (250 heures en test de brouillard salin NSS).

Comparée aux autres séries, la série GHA MODULAR possède une plus grande polyvalence grâce au corps monolithique caractérisé par une modularité de fixation élevée du fait de la tolérance d'usinage de tous les plans d'appui. Par contre, la carcasse est plus difficile à nettoyer et les réducteurs de cette série ne sont pas certifiés HACCP, ce qui explique pourquoi leur utilisation est conseillée dans des environnements alimentaires secs.

GX

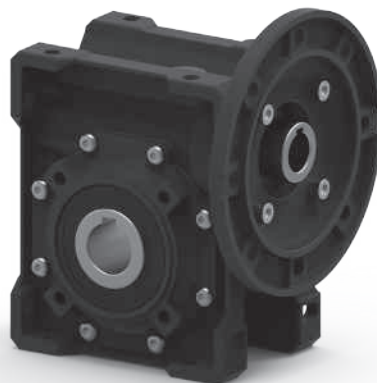

Tab. 1

SIMBOLO SYMBOL SYMBOLE	DEFINICION	DEFINITION	DEFINITION	UNIDAD DE MEDIDA MEASUREMENT UNIT UNITE DE MESURE
Fr₂	Carga radial	<i>Radial load</i>	Charge radiale	N
Fa₂	Carga axial	<i>Axial load</i>	Charge axiale	N
	Dimensiones	<i>Dimensions</i>	Dimensions	mm
FS'	Factor de servicio reductor	<i>Gearbox service factor</i>	Facteur de service réducteur	
FS	Factor de servicio solicitud	<i>Application service factor</i>	Facteur de service application	
i_n	Relación de transmisión nominal	<i>Rated reduction ratio</i>	Rapport de réduction nominal	
ir	Relación de transmisión real	<i>Actual reduction ratio</i>	Rapp.de réduction réel	
n₁	Velocidad de entrada	<i>Input speed</i>	Vitesse arbre d'entrée	min⁻¹
n₂	Velocidad de salida	<i>Output speed</i>	Vitesse arbre de sortie	min⁻¹
η	Rendimiento	<i>Efficiency</i>	Rendement	1 min ⁻¹ = 6.283 rad.
IEC	Motores acoplables	<i>Motor options</i>	Moteurs adaptés	
kg	Massa	<i>Mass</i>	Massa	kg
P	Potencia reductor	<i>Power gearbox</i>	Puissance réduction	kW
P'	Potencia requerida en la entrada	<i>Power required at input</i>	Puissance nécessaire à la entrée	kW
Pc	Potencia correcta	<i>Corrected power</i>	Puissance correcte	kW
P₁	Potencia del motor reductor	<i>Gearmotor power</i>	Puissance motoréducteur	kW
P₂	Potencia de salida	<i>Output power</i>	Puissance arbre de sortie	kW
P_{tc}	Potencia térmica correcta	<i>Corrected thermal power</i>	Puissance thermique correcte	kW
P₁₀	Potencia térmica	<i>Thermal power</i>	Puissance thermique	kW
P'	Potencia requerida en la salida	<i>Output power</i>	Puissance nécessaire à la sortie	kW
Rd	Rendimiento dinámico	<i>Dynamic efficiency</i>	Rendement dynamique	
Rs	Rendimiento estático	<i>Static efficiency</i>	Rendement statique	
Ta	Temperatura ambiente	<i>Ambient temperature</i>	Température ambiante	°C
T_{2M}	Par de salida del reductor	<i>Gearbox torque</i>	Couple du réducteur	Nm
T₂	Par de salida del motor reductor	<i>Gear motor torque</i>	Couple du motoréducteur	Nm
T_c	Momento torsor para la elección del reductor	<i>Torque to be used for the selection of the gearbox</i>	Couple à utiliser pour la sélection du réducteur	Nm
T_{2'}	Couple à utiliser pour la sélection du réducteur	<i>Required Torque</i>	Couple demandé	Nm

1.2 Factor de servicio

El factor de servicio **FS** permite calificar, en una primera aproximación, el tipo de la aplicación teniendo en cuenta la naturaleza de la carga (A, B, C), la duración del funcionamiento h/d (horas al día) y el número de arranques por hora. El coeficiente resultante tendrá que ser igual o inferior al factor de servicio del reductor **FS'** dado por la relación entre el par nominal del reductor **T_{2M}** indicado en el catálogo y el par **T_{2'}** requerido para la aplicación.

1.2 Service factor

*Service factor **FS** enables approximate qualification of the type of application, taking into account type of load (A,B,C), length of operation h/d (hours/day) and the number of starts-up/hour. The coefficient thus calculated must be equal to or lower than the gear unit service factor **FS'** which equals the ratio between **T_{2M}** (gear unit rated torque reported in the catalogue) and **T_{2'}** (torque required by the application).*

1.2 Facteur de service

Le facteur de service **FS** permet de qualifier, par approche, la typologie de l'application, compte tenu de la nature de la charge (A,B,C), de la durée du fonctionnement h/j (heures par jour) et du nombre de démarrages par heure. Le coefficient ainsi recherché devra être égal ou inférieur au facteur de service du réducteur **FS'** issu de la relation entre le couple nominal du réducteur **T_{2M}** - repris sur le catalogue - et le couple **T_{2'}** demandé par l'application.

$$FS' = \frac{T_{2M}}{T_2'} > FS$$

1.2 Factor de servicio

1.2 Service factor

1.2 Facteur de service

Los valores de FS indicados en la tabla 2 se refieren al accionamiento con motor eléctrico; en caso de usar un motor de combustión, se tendrá que tener en cuenta un factor multiplicativo de 1.3 si es de varios cilindros y de 1.5 si es de monocilindro. Si el motor eléctrico aplicado es autofrenante, es necesario considerar un número de arranques doble al efectivamente requerido.

FS values reported in table 2 refer to a drive unit equipped with an electric motor. If an internal combustion engine is used, a multiplication factor of 1.3 must be applied for a several-cylinder engine, 1.5 for a single-cylinder engine. If the electric motor is self-braking, consider twice the number of starts-up than those actually required.

Les valeurs de FS reprises au tabl. 2, concernent les entraînements par moteur électrique ; si l'on utilise un moteur à explosion, il faudra tenir compte d'un facteur de démultiplication 1.3, s'il à plusieurs cylindres, 1.5 s'il à un monocylindre. Si le moteur électrique utilisé possède un frein, il faudra prendre en compte un nombre de démarrages double par rapport à celui réellement nécessaire.

Tab. 2

Clase de carga Load class Classe de charge	h/d h/d h/j	N° ARRANQUES/HORA / N. START-UP/HOUR / N° DEMARRAGES/HEURE								
		2	4	8	16	32	63	125	250	500
A	4	0.8	0.8	0.9	0.9	1.0	1.1	1.1	1.2	1.2
	8	1.0	1.0	1.1	1.1	1.3	1.3	1.3	1.3	1.3
	16	1.3	1.3	1.3	1.3	1.5	1.5	1.5	1.5	1.5
	24	1.5	1.5	1.5	1.5	1.8	1.8	1.8	1.8	1.8
APLICACIONES / APPLICATIONS / APPLICATIONS										
Carga uniforme Uniform load Charge uniforme	Agitadores para líquidos puros	<i>Pure liquid agitators</i>			Agitateurs de liquides purs					
	Alimentadores para hornos	<i>Furnace feeders</i>			Alimentateurs de fours					
	Alimentadores de disco	<i>Disc feeders</i>			Alimentateurs à disque					
	Filtros de lavado neumáticos	<i>Air laundry filters</i>			Filtres de lavage à l'air					
	Generadores	<i>Generators</i>			Générateurs					
	Bombas centrífugas	<i>Centrifugal pumps</i>			Pompes centrifuges					
	Transportadores de carga uniforme	<i>Uniform load conveyors</i>			Convoyeurs à charge uniforme					

Clase de carga Load class Classe de charge	h/d h/d h/j	N° ARRANQUES/HORA / N. START-UP/HOUR / N° DEMARRAGES/HEURE								
		2	4	8	16	32	63	125	250	500
B	4	1.0	1.0	1.0	1.0	1.3	1.3	1.3	1.3	1.3
	8	1.3	1.3	1.3	1.3	1.5	1.5	1.5	1.5	1.5
	16	1.5	1.5	1.5	1.5	1.8	1.8	1.8	1.8	1.8
	24	1.8	1.8	1.8	1.8	2.2	2.2	2.2	2.2	2.2
APLICACIONES / APPLICATIONS / APPLICATIONS										
Carga con choques moderados Moderate shock load Charge avec chocs modérés	Agitadores para líquidos y sólidos	<i>Liquid and solid agitators</i>			Agitateurs de liquides et de solides					
	Cintas alimentadoras	<i>Belt conveyors</i>			Alimentateurs à bandes transporteuses					
	Tornos de servicio medio	<i>Medium service winches</i>			Treuil à service moyen					
	Filtros de grava	<i>Stone and gravel filters</i>			Filtres à pierres et gravier					
	Tornillos de evacuación de agua	<i>Dewatering screws</i>			Vis sans fin pour évacuation de l'eau					
	Floculadores	<i>Flocculator</i>			Floculateurs					
	Filtros de vacío	<i>Vacuum filters</i>			Filtres sous vide					
	Elevadores a cangilones	<i>Bucket elevators</i>			Elévateurs à godets					
	Grúas	<i>Cranes</i>			Grues					

Clase de carga Load class Classe de charge	h/d h/d h/j	N° ARRANQUES/HORA / N. START-UP/HOUR / N° DEMARRAGES/HEURE								
		2	4	8	16	32	63	125	250	500
C	4	1.3	1.3	1.3	1.3	1.5	1.5	1.5	1.5	1.5
	8	1.5	1.5	1.5	1.5	1.8	1.8	1.8	1.8	1.8
	16	1.8	1.8	1.8	1.8	2.2	2.2	2.2	2.2	2.2
	24	2.2	2.2	2.2	2.2	2.5	2.5	2.5	2.5	2.5
APLICACIONES / APPLICATIONS / APPLICATIONS										
Carga con Choques Pesados Heavy shock load Charge avec chocs intensifs	Grúas para servicio pesado	<i>Heavy duty hoists</i>			Treuil à service intensif					
	Extrusoras	<i>Extruders</i>			Extrudeuses					
	Calandras	<i>Crusher rubber calenders</i>			Calandres à caoutchouc					
	Prensas para ladrillos	<i>Brick presses</i>			Presses à briques					
	Planeadora	<i>Planing machine</i>			Raboteuses					
	Molinos de bolas	<i>Ball mills</i>			Moulins à bille					

1.3 Selección

Determinar la potencia de entrada P' (en base al par T_2 exigida por la aplicación), con la siguiente fórmula:

1.3 Selection

Calculate input power P' (on the basis of the torque T_2 required by the application), using the following formula:

1.3 Sélection

Déterminer la puissance en entrée P' (sur la base du couple T_2 nécessaire à l'application) selon la formule suivante :

$$P' = \frac{T_2' \cdot n_2}{9550 \cdot \eta} \quad [\text{kW}]$$

Calcular la relación de transmisión con la relación:

Calculate the transmission ratio with the following equation:

Calculer le rapport de transmission selon l'équation :

$$i_n = \frac{n_1}{n_2}$$

Elegir el factor de servicio FS para la aplicación en la Tabla 2.

Select the service factor FS of the application in Table 2.

Choisir le facteur de service FS de l'application au Tabl. 2.

Selección del reductor

A) $n_1 = 1400 \text{ min}^{-1}$

Se elegirá en las tablas de prestaciones de los reductores un grupo que en base a la relación próxima calculada admita una potencia:

Selecting a gearbox

A) $n_1 = 1400 \text{ min}^{-1}$

Consult the gear unit efficiency table; select a group whose ratio is close to the calculated ratio and which permits power:

Choix du réducteur

A) $n_1 = 1400 \text{ min}^{-1}$

Se reporter aux tableaux des performances réducteurs pour choisir un sous-ensemble qui correspond à un rapport avoisinant celui calculé et qui admet une puissance de :

$$P \geq P' \times \text{FS}$$

B) $n_1 \neq 1400 \text{ min}^{-1}$

Se deberá realizar la selección como en la situación anterior, pero en base a una potencia P_c corregida, con los coeficientes indicados en las tablas de cada tipo de reductor; verificando la relación:

B) $n_1 \neq 1400 \text{ min}^{-1}$

Make the selection as described above but on the basis of power P_c corrected by the coefficients reported in the tables. The following equation should be checked out:

B) $n_1 \neq 1400 \text{ min}^{-1}$

Effectuer le choix comme indiqué au cas précédent mais sur la base d'une puissance P_c corrigée par les coefficients du tableaux et après vérification de l'équation :

$$P_c \geq P' \times \text{FS}$$

Selección del motorreductor

C) $n_1 = 1400 \text{ min}^{-1}$ y FS = 1

Consultar en las tablas de las prestaciones de los motorreductores un grupo cuya potencia P_1 corresponda a la P' calculada.

D) $n_1 \neq 1400 \text{ min}^{-1}$ y FS $\neq 1$

La selección deberá realizarse como en el punto A) verificando que el tamaño del motor a instalar sea compatible con los admitidos por el reductor (IEC); lógicamente la potencia instalada deberá corresponder al valor P' requerido.

Selecting a gearmotor

C) $n_1 = 1400 \text{ min}^{-1}$ and FS = 1

Consult the gear motor efficiency table and select a group having power P_1 corresponding to calculated P' .

D) $n_1 \neq 1400 \text{ min}^{-1}$ or FS $\neq 1$

Follow the instructions at point A), checking that the size of the motor to be installed is compatible with the gear unit (IEC); obviously, installed power must correspond to the required P' value.

Choix du motoréducteur

C) $n_1 = 1400 \text{ min}^{-1}$ et FS = 1

Chercher aux tableaux des performances des motoréducteurs, un sous ensemble dont la puissance P_1 corresponde à la P' calculée.

D) $n_1 \neq 1400 \text{ min}^{-1}$ et FS $\neq 1$

Effectuer le choix comme pour le cas sous point A) en vérifiant que la taille du moteur à installer soit compatible avec celles admissibles pour les réducteurs (IEC), il est évident que la puissance installée devra correspondre à la valeur P' demandée.

1.4 Cargas radiales y axiales (N)

Las transmisiones realizadas mediante piñones de cadena, engranajes de modulo o poleas, generan fuerzas radiales (F_R) sobre el eje del reductor. Estas fuerzas pueden calcularse mediante la siguiente fórmula:

1.4 Radial and axial loads (N)

Transmissions implemented by means of chain pinions, wheels or pulleys generate radial forces (F_R) on the gear unit shafts. The entity of these forces may be calculated using the following formula:

1.4 Charges radiales et axiales (N)

Les transmissions obtenues par des pignons à chaîne, roues dentées ou poulies engendrent des forces radiales (F_R) qui agissent sur les arbres des réducteurs. L'intensité de ces efforts peut être calculée selon la formule:

$$F_R = \frac{K_R \cdot T}{d} \text{ [N]}$$

donde:

T = momento de torsión [Nm]
d = diámetro del piñón o de la polea [mm]
 K_R = 2000 para piñones de cadena
= 2500 para engranajes de módulo
= 3000 para poleas en V

where:

T = torque [Nm]
d = pinion or pulley diameter [mm]
 K_R = 2000 for chain pinion
= 2500 for wheel
= 3000 for V-belt pulley

où :

T = couple [Nm]
d = diamètre pignon ou poulie [mm]
 K_R = 2000 pour pignon à chaîne
= 2500 pour roues dentées
= 3000 pour poulies avec courroies trapézoïdales

Los valores de las cargas radiales y axiales generados por la aplicación deben ser siempre menores o iguales a los valores indicados en las tablas.

The values of the radial and axial loads generated by the application must always be lower than or equal to the admissible values reported in the tables.

Les valeurs des charges radiales et axiales engendrées par l'application, doivent être toujours inférieures ou égales à celles admissibles indiquées aux tableaux.

$$F_R \geq Fr_2$$

Verificación

Verificar que las cargas radiales que actúan sobre los ejes entren en los valores admisibles indicados en las tablas correspondientes. Estos valores (F_{R2}) se refieren a cargas que afectan al eje en la parte central del mismo, por lo que si el punto de aplicación es distinto, es necesario calcular los nuevos valores admisibles en la distancia (y) deseada.

Del mismo modo a lo indicado anteriormente, se deberán comprobar las cargas axiales con los valores mostrados en las tablas correspondientes.

Sobrecargas

En su normal funcionamiento el reductor admite una sobrecarga máxima instantánea de emergencia igual al 100% del par indicado T_2 . Si se temen que se produzcan sobrecargas frecuentes o superiores a las admitidas es indispensable proveerse de los correspondientes dispositivo para la limitación del par.

Engranajes

El cálculo de durabilidad y agotamiento de los engranajes se realiza según la norma ISO 6336 y ISO 10300, considerando el uso de aceite sintético.

Check-list

Check that the radial loads on the shafts fall within to the admissible values reported in the relative tables. Reported values (F_{R2}) refer to loads which affect the shaft at the half-way point of its projection; if the point of application is different, it is necessary to calculate the new admissible values at the desired distance (y).

In keeping with the above guidelines, axial loads should also be checked against the values reported in the relative tables.

Overloads

An emergency momentary overload up to 100% of T_2 torque is allowed during standard operation of the gearbox.

Should frequent or higher overloads be expected, it is necessary to install torque limiting devices.

Gears

Life and fatigue of the gears are calculated in compliance with ISO 6336 and ISO 10300. Calculations refer to utilization of synthetic oil

Vérifications

Vérifier que les charges radiales sur les arbres soient dans la plage des valeurs admissibles reprises aux tableaux correspondants. Ces valeurs (F_{R2}) se rapportent à des charges agissant à mi-arbre, par conséquent, si le point d'application est différent, il faut effectuer le calcul des nouvelles valeurs admissibles à la distance (y) désirée.

D'une façon analogue, les charges axiales aussi devront faire l'objet d'une vérification en les confrontant avec les valeurs des tableaux correspondants.

Surcharges

En général tous les réducteurs peuvent supporter des surcharges instantanées d'émergence s'élevant à 100% de la valeur du couple T_2 . Si l'on craint des surcharges supérieures, il faut absolument installer des dispositifs adaptés limitant le couple.

Engrenages

Le calcul de la durée et du travail des engrenages se fait suivant les normes ISO 6336 et ISO 10300, tout en considérant l'utilisation d'huile synthétique.

1.5 Potencia térmica

En las tablas indicadas en las secciones relativas a cada tipo de reductor se indican los valores de la potencia térmica nominal P_{10} (kW). Dicho valor representa la potencia máxima aplicable a la entrada del reductor, en servicio continuo y a una temperatura ambiente de 30°C, de modo que la temperatura del aceite no sobrepase el valor de 95°C, valor máximo permitido en el caso de productos estándar.

El valor de P_{10} no debe ser tomado en consideración si el funcionamiento es continuo durante un máximo de 1,5 horas, seguido por pausas de duración suficiente (aproximadamente 1 - 2 horas) para restablecer en el reductor la temperatura ambiente.

Los valores de P_{10} deben ser corregidos mediante los siguientes coeficientes, considerando las condiciones reales de funcionamiento, obteniendo los valores de potencia térmica correcta P_{tc} .

1.5 Thermal power

The different sections dedicated to each type of gearbox contain tables reporting the values of rated thermal power P_{10} (kW). Reported values correspond to the maximum admissible power at gearbox input, on continuous duty and with ambient temperature of 30°C, so that oil temperature does not exceed 95°C, which is the max. admissible value for standard products.

P_{10} value should not be taken into account in case of continuous duty for max. 1.5 hours followed by pauses which are long enough to bring the gearbox back to ambient temperature (roughly 1 - 2 hours).

In order to comply with the actual operating conditions, P_{10} values should be corrected with the following coefficients, thus obtaining the values of corrected thermal power P_{tc} .

1.5 Puissance thermique

Dans les tableaux concernant les sections relatives à chaque type de réducteur, sont indiquées les valeurs de la puissance thermique nominale P_{10} (kW). Elle représente la puissance max. applicable à l'entrée du réducteur, en service continu et à une température max. ambiante de 30°C afin d'éviter que la température de l'huile dépasse la valeur de 95°C.

La valeur du P_{10} ne doit pas être prise en considération si le fonctionnement est continu pour un max. de 1.5 heures suivi par des pauses d'une durée suffisante (1- 2 heures) afin de rétablir la température ambiante sur le réducteur.

Les valeurs de P_{10} doivent être corrigées par le moyen des coefficients suivants, afin de considérer réelles les conditions de fonctionnement, et obtenir les valeurs de puissance thermique correcte P_{tc} .

$$P_{tc} = P_{10} \cdot ft \cdot fv \cdot fu \text{ (kW)}$$

Donde:

ft = coeficiente de temperatura (v. tabla 3)

Where:

ft = temperature coefficient (see table 3)

Où :

ft = coefficient de température (voir tabl. 3)

Tab. 3

Tc (°C)	0	5	10	15	20	25	30	35	40	45	50
ft	1.46	1.38	1.31	1.23	1.15	1.1	1	0.92	0.85	0.77	0.69

(Tc (°C) es la temperatura ambiente)

(Tc (°C) is the ambient temperature)

(Tc (°C) est la température ambiante)

fv = coeficiente de ventilación

- fv= 1.45 con ventilación forzada; directamente al reductor
- fv= 1.25 con ventilación forzada secundaria a otros dispositivos (polea, ventilación motor, etc)
- fv= 1 refrigeración natural (situación estándar)
- fv= 0.5 en ambiente cerrado y estrecho (cárter)

fv = cooling coefficient

- fv= 1.45 forced cooling with specific fan
- fv= 1.25 forced cooling secondary to other devices (pulleys, motor fans, etc)
- fv= 1 natural cooling (standard)
- fv= 0.5 in a closed and narrow environment

fv = coefficient de ventilation

- fv= 1.45 avec ventilation forcée efficace avec ventilateur livré
- fv= 1.25 avec ventilation forcée secondaire à d'autres dispositifs (poules, ventilateurs moteur, etc)
- fv= 1 réfrigération naturelle (situation standard)
- fv= 0.5 dans une ambient close et fermée (carter)

fu coeficiente de utilización (v. tab. 4)

fu = utilization coefficient (see table 4)

fu = coefficient d'utilisation (voir tabl. 4)

Tab. 4

Dt (min)	10	20	30	40	50	60
fu	1.6	1.35	1.2	1.1	1.05	1

donde Dt son los minutos de funcionamiento en una hora

Dt is minutes of operation per hour

Où Dt sont les minutes de fonctionnement à l'heure

1.6 Lubricación

Todos los reductores se suministran con lubricante sintético a base de PAG con índice de viscosidad ISO VG 320 e ISO VG150 (solo GHA PREMIUM).

Los cojinetes del eje rápido se lubrican siempre con grasa de base sintética para todas las posiciones de montaje. Solo para las posiciones B6-B7, para una correcta lubricación, también se engrasan los cojinetes del eje lento. Esto significa que solo desde las posiciones de montaje B6-B7 se puede pasar a todas las otras posiciones, modificando exclusivamente las cantidades de aceite, tal como se indica en las respectivas tablas. En cambio, en cuanto a las posiciones de montaje B3-B8- V5-V6, solo pueden intercambiarse entre sí, modificando las cantidades de aceite de la serie Premium, sin modificar las cantidades de aceite de las series Classic y Modular.

La grasa utilizada es FUCHS CASSIDA GREASE HTS2.

Una atenta elección del tipo de lubricante, en función de las condiciones de funcionamiento y ambientales, permite que los reductores logren los mejores rendimientos.

Las prestaciones de los reductores indicadas en las tablas de los datos técnicos se han calculado teniendo en cuenta el uso de aceite alimentario sintético: ACEITE FUCHS CASSIDA FLUID 150 para GHA; ACEITE FUCHS CASSIDA FLUID 320 para GK, GT, GX.

Para campos de aplicación marítimos (M), se utilizan lubricantes de la serie de tornillo sin fin estándar TRAMEC.

1.7 Instalación

Monte el reductor de modo tal que se elimine cualquier vibración.

Preste mucha atención a la alineación del reductor con el motor y la máquina que se debe controlar, interponiendo juntas elásticas o autoalineantes donde sea posible.

En caso de que el reductor sea sometido a sobrecargas prolongadas, choques o peligros de bloqueo, instale protectores de motor, limitadores de par, juntas hidráulicas u otros dispositivos similares.

Asegúrese de no superar los valores permitidos de carga radial y axial que actúan sobre los ejes rápido y lento.

Asegúrese de que las piezas que deben montarse en los reductores estén elaboradas con tolerancia **EJE ISO h6 ORIFICIO ISO H7**.

1.6 Lubrication

All the reducers are supplied complete with PAG-based synthetic lubricant with ISO VG 320 and ISO VG150 viscosity index (only GHA PREMIUM).

The input shaft bearings are always lubricated with synthetic grease for all assembly positions. Only for positions B6-B7, for correct lubrication, the output shaft bearings are also greased. This means that only from assembly positions B6-B7 it is possible to switch to all the other positions, modifying solely the amounts of oil, as indicated in the relative tables. While with regard to assembly positions B3-B8-V5-V6, they are only interchangeable between them, modifying the amounts of oil for the Premium series, without modifying the amounts of oil for the CLASSIC and MODULAR series.

The grease used is FUCHS CASSIDA GREASE HTS2.

A careful choice of the type of lubricant, depending on the operating and environmental conditions, allows the reducers to achieve optimum performance.

The performance of the reducers indicated in the technical data tables have been calculated considering the use of synthetic food oil: FUCHS CASSIDA FLUID OIL 150 for GHA; FUCHS CASSIDA FLUID OIL 320 for GK, GT, GX.

For the marine application field (M), standard TRAMEC worm gear series lubricants are used.

1.7 Installation

Install the gearbox so that any vibration is eliminated.

Take special care with the alignment between the gear units, the motor and the driven machine, fitting flexible or self adjusting couplings wherever possible.

If the gearbox is subject to prolonged overloads, shocks or possible jamming, fit overload cutouts, torque limiters, hydraulic couplings or other similar devices.

Do not exceed allowed radial and axial loads on the input and output shafts.

*Ensure that the components to be fitted on the gear units are machined with tolerance **SHAFT ISO h6 HOLE ISO H7**.*

1.6 Lubrification

Tous les réducteurs sont fournis avec du lubrifiant synthétique à base de PAG avec un indice de viscosité ISO VG 320 et ISO VG150 (uniquement pour GHA PREMIUM).

Les roulements de l'arbre rapide doivent toujours être lubrifiés avec de la graisse à base synthétique pour toutes les positions de montage. Uniquement pour les pos. B6-B7, pour une lubrification correcte, les roulements de l'arbre lent doivent aussi être graissés. Cela signifie qu'il n'est possible de passer à toutes les autres positions qu'à partir des positions de montage B6-B7, en modifiant uniquement les quantités d'huile, comme indiqué dans les tableaux correspondants. En ce qui concerne par contre les positions de montage B3-B8-V5-V6, elles ne peuvent être interchangeables qu'entre elles, en modifiant les quantités d'huile pour la série Premium, sans modifier la quantité d'huile pour la série Classic et Modular.

C'est la graisse FUCHS CASSIDA GREASE HTS2 qui est utilisée.

Un choix judicieux du type de lubrifiant, en fonction des conditions opérationnelles et de l'environnement, permet aux réducteurs d'atteindre des performances optimales.

Les performances des réducteurs indiquées dans les tableaux de données techniques ont été calculées en tenant compte de l'utilisation d'huile alimentaire synthétique : HUILE FUCHS CASSIDA FLUID 150 pour GHA ; HUILE FUCHS CASSIDA FLUID 320 pour GK, GT, GX.

Pour le domaine d'application marin (M), on utilise des lubrifiants de la série vis sans fin standard TRAMEC.

1.7 Installation

Monter le réducteur de manière à éliminer toute vibration.

Soigner particulièrement l'alignement du réducteur avec le moteur et la machine à commander, en interposant le cas échéant des joints élastiques ou à alignement automatique.

Lorsque le réducteur est soumis à des surcharges prolongées, à des chocs ou à des risques de blocage, installer des disjoncteurs de moteur, des limiteurs de couple, des joints hydrauliques ou d'autres dispositifs similaires.

Veillez à ne pas dépasser les valeurs autorisées de charge radiale et axiale qui agissent sur les arbres rapide et lent.

Veiller à ce que les organes à monter sur les réducteurs soient usinés avec une tolérance **ARBRE ISO h6 ALÉSAGE ISO H7**.

Antes de efectuar el montaje, limpie y lubrique las superficies, para evitar peligros de gripado y oxidación por contacto.

Before assembling, clean and lubricate the surfaces to prevent seizure and contact oxidation.

Avant d'effectuer le montage, nettoyer et lubrifier les surfaces afin d'éviter le risque de grippage et l'oxydation par contact.

El montaje debe efectuarse con la ayuda de tirantes y extractores, mediante el agujero roscado que se encuentra en el cabezal de los extremos de los ejes.

Assembly is to be carried out with the aid of tie-rods and extractors, using the threaded hole at the shaft ends.

Le montage doit être effectué à l'aide de tirants et d'extracteurs en utilisant le trou fileté situé aux extrémités des arbres.

Todos los reductores y motorreductores mencionados en este manual están destinados para uso industrial con una temperatura ambiente de -20 °C a +40 °C a una altura máxima de 1000 metros sobre el nivel del mar.

All gearboxes and gear motors mentioned in this catalog are intended for industrial use and operation at a ambient temperature between -20°C and +40°C, at an altitude of max. 1000 m above sea level.

Tous les réducteurs et les motoréducteurs cités dans ce manuel sont destinés à un usage industriel à une température ambiante comprise entre -20 °C et +40 °C et à une altitude max. de 1000 m. au-dessus du niveau de la mer.

Para todas las demás advertencias, consulte el manual de «uso y mantenimiento» que puede descargarse de www.tramec.it

For all other instructions check the "Use and Maintenance Manual" which can be downloaded from our web site www.tramec.it

Pour toutes les autres mises en garde, consulter le manuel « d'utilisation et d'entretien » téléchargeable sur le site www.tramec.it herunter.

1.8 Rodaje

1.8 Running-in

1.8 Rodage

Se recomienda aumentar gradualmente la potencia transmitida o limitar el momento torsor resistente de la máquina que se debe controlar durante las primeras horas de funcionamiento.

Increase the transmitted power gradually or limit the resistant torque of the driven machine for the first few operating hours.

Il est conseillé d'augmenter progressivement au fil du temps la puissance transmise ou de limiter le couple résistant de la machine à contrôler pendant les premières heures de fonctionnement.

1.9 Mantenimiento

1.9 Maintenance

1.9 Entretien

Controle periódicamente el nivel del lubricante y cámbielo después de 12500 horas de funcionamiento.

Check the lubricant level regularly and change after 12500 operating hours.

Contrôler périodiquement le niveau du lubrifiant et effectuer le changement après 12 500 heures de fonctionnement.

Si el reductor permanece inactivo durante mucho tiempo en un ambiente con un alto porcentaje de humedad, se recomienda llenarlo completamente con aceite. Naturalmente, en el momento de la próxima puesta en funcionamiento, se deberá restablecer el nivel del lubricante.

When the gearbox is left unused in a highly humid environment fill it completely with oil. Importantly the oil must be returned to the operating level before the unit is used again.

Lorsque le réducteur reste longtemps inactif dans un environnement très humide, il est conseillé de le remplir complètement d'huile. Naturellement, lors de la mise en service suivante, il sera nécessaire de rétablir le niveau de lubrifiant.

1.10 Operaciones de lavado

Los reductores de la serie PREMIUM pueden limpiarse con un chorro de agua a presión. Para garantizar la máxima durabilidad del reductor, en las proximidades del eje hueco de salida, aunque tenga una tapa que proteja las juntas hasta 0,2 mm con respecto al eje, se recomienda no dirigir el chorro de agua a presión hacia la zona de interconexión entre el eje hueco y la carcasa.

Para los reductores GKC, GXC y GTF, se debe asegurar un cierto cuidado de las juntas evitando el uso de chorros de agua a presión contra las mismas.

Los reductores GHA PREMIUM pueden lavarse con soluciones detergentes o desinfectantes profesionales. Para conservar las propiedades del tratamiento superficial a lo largo del tiempo, hay algunos principios activos más adecuados que otros. En particular, algunos son muy agresivos. ¡La elección es importante!

Sobre la base de las pruebas efectuadas con soluciones detergentes o desinfectantes, se ha llegado a las siguientes conclusiones:

- **El ácido peracético** y las **sales de amonio cuaternario** son los principios activos más adecuados para las superficies del GHA Premium.
- **El hipoclorito** es un principio activo que tiende a opacar las superficies, pero permite realizar 270 ciclos de lavado antes de llegar a deteriorar las superficies.
- **El hidróxido de sodio/potasio** es un principio activo incompatible con el tratamiento con G.H.A.

1.10 Washing operations

On the PREMIUM series reducers, cleaning with a pressurised water jet is permitted. To ensure the maximum durability of the reducer, near the hollow output shaft, despite having a cover that protects the seals up to 0.2 mm from the shaft, it is recommended not to direct the pressurised jet in the interface area between the hollow shaft and the casing.

For GKC, GXC and GTF reducers, the seals must be treated carefully, avoiding pressurised jets of water directed on them.

GHA PREMIUM reducers can be washed with detergent and/or disinfectant or professional sanitising solutions. To preserve the properties of the surface treatment over time, some active ingredients are more suitable than others. In particular, some are very harsh. The choice is important!

On the basis of tests carried out with detergent and/or disinfectant or sanitising solutions, the following emerged:

- **peracetic acid and quaternary ammonium salts** are the most suitable active ingredients for GHA Premium surfaces.
- **Hypochlorite** is an active ingredient that tends to tarnish the surfaces but which still allows 270 washing cycles to be carried out before deteriorating the surface.
- **Sodium/potassium hydroxide** is an active ingredient incompatible with G.H.A..

1.10 Opérations de lavage

Il est possible d'effectuer le lavage des réducteurs de la série PREMIUM au moyen de jets d'eau sous pression. Pour garantir une durée maximale du réducteur, à proximité de l'arbre de sortie creux, bien que le couvercle protège les joints jusqu'à 0,2 mm de l'arbre, il est recommandé de ne pas diriger le jet sous pression dans la zone d'interface entre arbre creux et carcasse.

Pour les réducteurs GKC, GXC et GTF, il est nécessaire de faire attention aux joints d'étanchéité en évitant de diriger des jets d'eau sous pression vers ces derniers.

Les réducteurs GHA PREMIUM peuvent être lavés avec de solutions de détergents et/ou de désinfectants professionnels. Pour préserver les propriétés du traitement de surface au fil du temps, certains principes actifs sont plus appropriés que d'autres. Certains sont notamment très agressifs. Il est important de bien choisir !

Selon des essais réalisés avec des solutions de détergents et/ou de désinfectants professionnels, il est apparu que :

- **l'acide peracétique** et les **sels d'ammonium quaternaire** sont les principes actifs les plus adaptés aux surfaces du réducteur GHA Premium.

- **L'hypochlorite** est un principe actif qui a tendance à ternir les surfaces mais qui permet tout de même d'effectuer 270 cycles de lavage avant que celles-ci ne se détériorent.

- **L'hydroxyde de sodium/potassium** est un principe actif incompatible avec le traitement G.H.A.

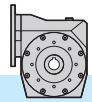

2.0	REDUCTORES TORNILLO SIN FIN GHA	GHA WORM GEARBOXES	RÉDUCTEUR À ROUE ET VIS SANS FIN GHA
2.1	Características	<i>Characteristics</i>	Caractéristiques 22
2.2	Nomenclatura	<i>Designation</i>	Désignation 23
2.3	Rendimiento	<i>Efficiency</i>	Rendement 24
2.4	Irreversibilidad	<i>Irreversibility</i>	Irréversibilité 24
2.5	Juego angular	<i>Backlash</i>	Jeu d'angle 25
2.6	Cargas radiales	<i>Radial load</i>	Charges radiales 26
2.7	Sentido de rotación	<i>Direction of rotation</i>	Sens de rotation 26
2.8	Lubricación y posición de montaje	<i>Lubrication and mounting position</i>	Lubrification et positions de montage 27
2.9	Posición del tablero de Borne	<i>Terminal board position</i>	Position de la boîte à bornes 27
2.10	Posición del prensaestopas	<i>Cable gland position</i>	Position du presse-étoupe 28
2.11	Datos técnicos	<i>Technical data</i>	Données techniques 29
2.12	Momento de inercia	<i>Moment of inertia</i>	Momento de inercia 31
2.13	Tamaño	<i>Dimensions</i>	Dimensions 32
2.14	Accesorios	<i>Accessories</i>	Accessoires 35
2.15	Lista de recambios	<i>Spare parts list</i>	Liste des pièces détachées 36

GHA - PREMIUM

La serie PREMIUM es la serie puntera de la gama de reductores GHA, gracias a sus especiales características de NANOTECNOLOGÍA potenciadas del revestimiento.

El tratamiento GHA potenciado y el especial diseño externo con superficie lisa, hacen de los reductores de la serie PREMIUM, la solución ideal para una amplia gama de aplicaciones en ambientes sensibles, en los sectores de la industria ALIMENTARIA, FARMACÉUTICA y MARÍTIMA.

A pesar de que los reductores de la serie GHA PREMIUM están certificados como dispositivos adecuados para utilizarse en máquinas alimentarias y, por lo tanto, para aplicaciones en plantas de producción y manipulación de alimentos, no están certificados para utilizarse en contacto con alimentos.

GHA - PREMIUM

The PREMIUM series represents the flagship series within the range of GHA reducers, thanks to the special enhanced NANOTECHNOLOGICAL characteristics of the coating.

The enhanced GHA treatment and the particular external design with its smooth surface make the PREMIUM series reducers the ideal solution for a wide range of applications in sensitive environments in the FOOD, PHARMACEUTICAL and MARINE sectors.

Although the GHA PREMIUM series reducers are certified as suitable devices for use on food processing machines and therefore for applications that operate in food production and handling plants, they are not certified for use in contact with food.

GHA - PREMIUM

La série PREMIUM représente la série phare au sein de la gamme de réducteurs GHA, grâce à leurs caractéristiques NANOTECHNOLOGIQUES spéciales, renforcées par le revêtement.

Grâce au traitement GHA renforcé et à leur design externe particulier à la surface lisse, les réducteurs de la série PREMIUM sont la solution idéale pour une large gamme d'applications dans des environnements sensibles des secteurs ALIMENTAIRE, PHARMACEUTIQUE et MARIN.

Bien que les réducteurs de la série GHA PREMIUM soient certifiés en tant que dispositifs adaptés à l'utilisation sur des machines alimentaires et donc pour des applications qui opèrent dans des usines de production et de manipulation des aliments, ils ne sont pas certifiés pour l'utilisation au contact des aliments.



09/2019

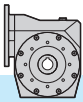

2.1 Características

- Los reductores de la serie con tornillo sin fin GHA PREMIUM tienen una carcasa compacta, para todos los tamaños.
- La carcasa y las bridas de aleación de aluminio son arenadas y tratadas con la tecnología G.H.A.
- La serie GHA PREMIUM se encuentra disponible exclusivamente en la versión preparada para la conexión del motor (PAM) y sin eje de entrada macho.
- El tornillo sin fin es de acero aleado cementado-templado y rectificado.
- La corona tiene un buje de acero inoxidable AISI 316 y un anillo dentado de bronce GCuSn12.
- Equipados con pernos de acero inoxidable, juntas de material certificado por la FDA y lubricantes para la industria alimentaria (categoría de certificación NSF H1).
- Para aplicaciones en el sector marítimo (M), no se utilizan lubricantes NSF H1 ni juntas de material certificado por la FDA.
- El eje hueco de salida se suministra de serie en acero inoxidable AISI 316 y se encuentra disponible el accesorio del brazo de reacción en aleación de aluminio con tratamiento G.H.A., montado con tornillos de acero inoxidable.

2.1 Characteristics

- *The GHA PREMIUM worm gear series reducers feature a compact casing for all sizes.*
- *The casing and the flanges made of aluminium alloy are tumbled and treated with G.H.A technology.*
- *The GHA PREMIUM series is only available in the version designed for motor coupling (PAM) and not with a male input shaft.*
- *The worm gear is made of cemented-tempered alloy steel and is ground.*
- *The crown wheel features an AISI 316 stainless steel hub and a GCuSn12 bronze toothed ring.*
- *Equipped with stainless steel nuts and bolts, seals made of FDA-certified material and lubricants for the food industry (NSF H1 certification category).*
- *For applications in the marine sector (M), NSF H1 lubricants and FDA-certified seals are not used.*
- *The hollow output shaft is supplied as standard in AISI 316 stainless steel and there is also a reaction arm accessory available, made of aluminium alloy with G.H.A. treatment, mounted with stainless steel screws.*

2.1 Caractéristiques

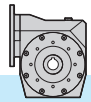

- Les réducteurs de la série à vis sans fin GHA PREMIUM présentent, pour toutes les tailles, une forme de la carcasse compacte.
- La carcasse et les bridas en alliage d'aluminium sont polies par tonnelage et traitées avec la technologie G.H.A.
- La série GHA PREMIUM n'est disponible que dans la version prévue pour la fixation du moteur (PAM) et non pas avec un arbre d'entrée mâle.
- La vis sans fin, réalisée en acier allié cimenté-trempe, est rectifiée.
- Le moyeu de la couronne est en acier INOX AISI 316 et l'anneau denté en bronze GCuSn12.
- Pourvus de boulons en INOX, de joints d'étanchéité réalisés dans un matériau certifié FDA et lubrifiants pour l'industrie alimentaire (catégorie de certification NSF H1).
- Pour les applications dans le secteur marin (M), les lubrifiants NSF H1 et joints d'étanchéité en matériau certifié FDA ne sont pas utilisés.
- L'arbre de sortie creux en acier INOX AISI 316 est fourni de série et l'accessoire bras de réaction est disponible en alliage d'aluminium avec traitement G.H.A., monté avec des vis en acier inoxydable.



2.2 Nomenclatura

2.2 Designation

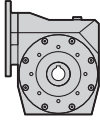
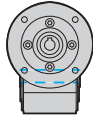
2.2 Désignation

Reductores Gearbox Réducteur	Tamaño Size Taille	Tamaño Size Taille	Relación redu. Ratio Rapport de réduction	Enganche motor.Motor coupling montage moteur	Posición montaje Mounting position Position Montage	eje de salida de cable Hollow output shaft arbre de sortie de câble	Brazo de reacción Torque arm Bras de réaction	Campo de aplicación Field of application Domaine d'application
GHA	50	PP	10/1	P.A.M	B3	H25	BR	A
	30 40 50 63 75	PP CC PD PS	5 7.5 10 15 20 25 30 40 50 65 80 100	56 B14 63 B14 71 B14 80 B14 90 B14 100 B14 112 B14	B3, B6 B7, B8 V5, V6	 H..	 BR	A Alimentario y farmacéutico Food and Pharmaceutical Alimentaire et Pharmaceutique M * Marítimo Marine Marin

*: a petición

*: on request

*: sur demande

GHA...PP

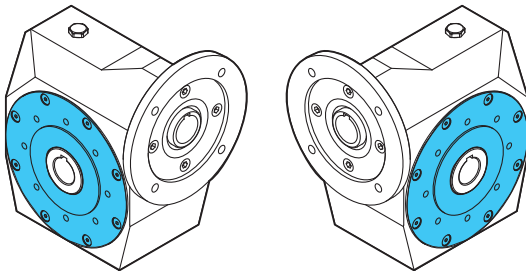

GHA...CC

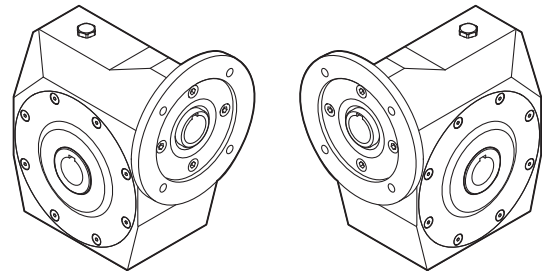

GHA...PD

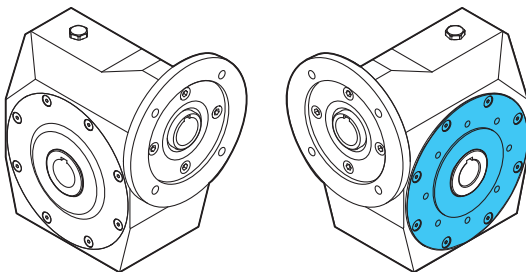

GHA...PS

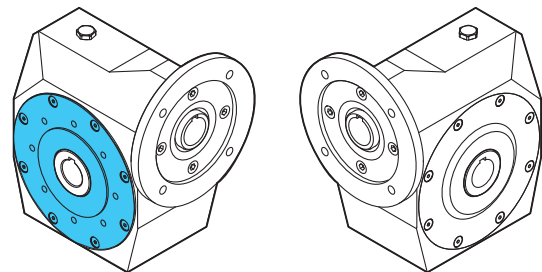

Notas:

PP = Doble brida pendular
CC = Doble tapa
PD = Tapa y brida pendular derecha
PS = Tapa y brida pendular izquierda

Notes:

PP = Double shaft-mounted flange
CC = Double cover
PD = Cover and right hand shaft-mounted flange
PS = Cover and left hand shaft-mounted flange

Notes :

PP = Double bride pendulaire
CC = Double couvercle
PD = Couvercle et bride pendulaire droite
PG = Couvercle et bride pendulaire gauche

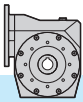

2.3 Rendimiento

Rd - Es el rendimiento dinámico, definido como la relación entre la potencia de salida P_2 y aquella con entrada P_1 . Este depende principalmente de la velocidad de roce, del tipo de lubricante y de la angulación del tornillo. Los valores indicados en las tablas son válidos si se aplica el correspondiente par en salida. Durante la fase de rodaje, aproximadamente las primeras 300 horas de funcionamiento bajo carga, el valor debe ser considerado inferior al 30% respecto al indicado en la tabla.

Rs - Es el rendimiento estático que se obtiene al arrancar el reductor y varía en base a la relación de reducción. Para una correcta elección del reductor a emplear, es importante en las aplicaciones en las cuales no se alcanzan nunca las condiciones de régimen como en los funcionamientos intermitentes. De forma análoga al caso dinámico, también el rendimiento estático durante el rodaje es inferior al 30% respecto al valor indicado en la tabla.

2.3 Efficiency

Rd - dynamic efficiency, defined as the ratio between P_2 output power and P_1 input power. It mainly depends on the slipping speed, the type of lubricant and the lead angle. The values reported in the table are valid when the corresponding output torque is applied. During the first 300 operating hours under load, the value to be considered is 30% lower than that reported in the table.

Rs - static efficiency at gearbox start-up; it changes depending on the reduction ratio. Rs value is important for selecting the right gearbox for applications where a steady state is never achieved, as for intermittent duty applications. Same as dynamic efficiency, static efficiency too during the running-in period will be 30% lower than the value reported in the table.

2.3 Rendement

Rd - Le rendement dynamique est le rapport entre la puissance de sortie P_2 et la puissance d'entrée P_1 . Le rendement dépend principalement de la vitesse de glissement, du type de lubrification et de l'angle d'hélice. Les valeurs indiquées dans les tableaux sont valables si l'on applique le couple correspondant à la sortie. En phase de rodage, qui représente environ les 300 premières heures de fonctionnement à pleine charge, la valeur doit être considérée comme étant inférieure de 30% à celle indiquée dans le tableau.

Rs - Il s'agit du rendement statique au démarrage du réducteur. Il varie en fonction du rapport de réduction. Le Rs est donc important pour choisir le réducteur à utiliser, surtout pour des applications où les conditions de régime ne sont jamais optimales, comme par exemple dans des applications à charges intermittentes. Comme pour le cas dynamique, le rendement statique durant le rodage est lui aussi inférieur de 30% par rapport à la valeur indiquée dans le tableau.

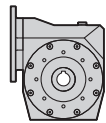

GHA	Rs											
	5	7.5	10	15	20	25	30	40	50	65	80	100
30	0.70	0.67	0.62	0.55	0.47	0.43	0.39	0.30	0.27	0.25	0.22	0.21
40	0.69	0.67	0.63	0.55	0.52	0.45	0.40	0.35	0.29	0.26	0.25	0.23
50	0.69	0.68	0.65	0.58	0.53	0.47	0.41	0.37	0.32	0.28	0.25	0.23
63	0.70	0.68	0.65	0.57	0.55	0.50	0.47	0.38	0.33	0.29	0.28	0.23
75	/	0.68	0.65	0.58	0.55	0.51	0.43	0.39	0.35	0.31	0.28	0.24

2.4 Irreversibilidad

En las aplicaciones donde sea necesario evitar la transmisión del movimiento reaccionario o sostener la carga, en ausencia de la alimentación eléctrica, es aconsejable adaptar frenos externos.

En los reductores de tornillo sin fin aparece esta característica natural, denominada grado de irreversibilidad, que crece al aumentar la relación de reducción por estar estrechamente ligado al relativo rendimiento.

Para obtener altos grados de irreversibilidad en necesario adoptar las relaciones de reducción más altas, sin olvidar que el rendimiento tiende a crecer durante las primeras 500 horas de funcionamiento estabilizándose después en los valores indicados en el catálogo.

Irreversibilidad estática

Condiciones para impedir la rotación, comandado por el eje lento, sin excluir posibles retornos lentos en el caso que la carga sea sometida a vibraciones.

Rs < 0.45 se tiene irreversibilidad
Rs = 0.45 ÷ 0.55 irreversibilidad incierta
Rs > 0.55 se tiene reversibilidad

2.4 Irreversibility

The use of external brakes is advised in case of applications where backwards motion must be hindered and the load must be held should the feed be cut off.

Some worm gearboxes feature natural irreversibility. The higher the ratio, the higher is the irreversibility, since it is strictly dependent on the relative efficiency.

In order to achieve high irreversibility it is therefore necessary to select higher efficiency reduction ratios not to forget that the efficiency is growing during the first 500 hours life until it stabilizes to the values mentioned in the catalogue.

Static irreversibility

Static irreversibility occurs when the rotation controlled by the output shaft is hindered; possible slow returns cannot be excluded should the load be subject to vibrations.

Rs < 0.45 provides irreversibility
Rs = 0.45 ÷ 0.55 irreversibility is uncertain
Rs > 0.55 reversibility is possible

2.4 Irréversibilité

En cas d'absence d'alimentation électrique, il est conseillé de choisir des freins extérieurs pour les applications où il faut éviter la transmission du mouvement rétrograde ou bien soutenir la charge.

Le degré d'irréversibilité est une caractéristique naturelle des réducteurs à roue et vis sans fin. Elle augmente en même temps que le rapport de réduction puisqu'elle est liée au rendement.

Pour obtenir d'importants degrés d'irréversibilité, il faut donc utiliser des rapports de réductions plus élevés, sans oublier que le rendement tend à augmenter au bout des 500 premières heures de service pour se stabiliser par la suite aux valeurs mentionnées sur le catalogue.

Irréversibilité statique

Condition qui empêche la rotation commandée par l'arbre de sortie. D'éventuels retours lents ne sont pas à exclure si la charge est soumise à des vibrations.

Rs < 0.45 produit une irréversibilité
Rs = 0.45 ÷ 0.55 irréversibilité incertaine
Rs > 0.55 réversibilité possible

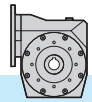

Irreversibilidad dinámica

Condición de detención por lo tanto el soporte de la carga en el momento en que se suspende la acción de comando. La condición es más difícil de obtener cuando es influenciada por el rendimiento dinámico, la velocidad de rotación, posibles vibraciones que la carga puede generar y por la dirección del movimiento en relación de la carga.

Esta última condición es muy evidente en los elevadores: una carga en ascenso, suspendida la acción de comando, debe pararse y asumir una velocidad cero (rendimiento estático) antes de invertir el movimiento y caer por gravedad.

Una carga en descenso, en cambio, tiende a continuar en su movimiento obstruido en caída, por el rendimiento dinámico.

Rd < 0.45 se tiene irreversibilidad
Rd = 0.45 ÷ 0.55 irreversibilidad incierta
Rd > 0.55 se tiene reversibilidad

Dynamic irreversibility

Dynamic irreversibility is characterized by stillstand and hold of the load when the drive stops. It is more difficult to achieve this condition because it is influenced by dynamic efficiency, speed of rotation and possible vibrations generated by the motion direction with regard to the load.

This last condition is much more evident during the lifting : if the drive stops during the lifting of the load this has to come to a speed equals to zero (static irreversibility) before the reversal of motion rotation and its drop for gravity.

On the contrary the load during its descent gets its motion obstructed by its dynamic efficiency.

Rd < 0.45 provides irreversibility
Rd = 0.45 ÷ 0.55 irreversibility is uncertain
Rd > 0.55 reversibility is possible

Irréversibilité dynamique

Condition nécessaire pour arrêter et donc soutenir la charge au moment de l'arrêt de l'action de commande. Cette condition est la plus difficile à obtenir puisqu'elle est influencée par le rendement dynamique, la vitesse de rotation et les rotations éventuelles produites par la charge et la direction du mouvement par rapport à la charge.

Cette dernière condition est particulièrement évidente lors des élévations : une charge en montée, lorsque l'action de commande cesse, doit s'arrêter et sa vitesse est alors égale à zéro (rendement statique) avant d'inverser le mouvement et tomber sous l'effet de la force de gravité.

Une charge en descente a, au contraire, tendance à poursuivre son mouvement, gênée dans sa chute par le rendement dynamique.

Rd < 0.45 produit irréversibilité
Rd = 0.45 ÷ 0.55 irréversibilité incertaine
Rd > 0.55 réversibilité possible

2.5 Juego angular

Juego angular standard

Medido bloqueando el eje de entrada, y girando el eje de salida en las dos direcciones aplicando el par estrictamente necesario para crear el contacto entre los dientes de los engranajes, como máximo igual al 2% del par nominal (T_{2M}).

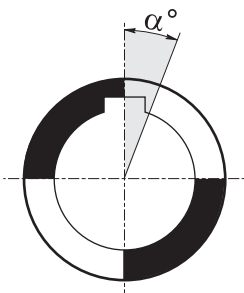

2.5 Backlash

Backlash

Angular backlash measured after having blocked the input shaft by rotating output shaft in both directions and applying the torque which is strictly necessary to create a contact between the teeth of the gears. The applied torque should be at most 2% of the max. torque (T_{2M}).

2.5 Jeu d'angle

Jeu d'angle standard

Mesuré en bloquant l'arbre d'entrée et en tournant l'arbre dans les deux directions en appliquant le couple strictement nécessaire pour créer le contact avec les dents des engrenages, équivalent à 2% max. du couple nominal (T_{2M}).

GHA					
i_n	30	40	50	63	75
	max	max	max	max	max
5	16'	13.5'	10.5'	10'	/
7.5	16'	13.5'	10.5'	10'	10'
10	16'	13.5'	10.5'	10'	10'
15	16'	13.5'	10.5'	10'	10'
20	14.5'	12'	9.5'	8.5'	8.5'
25	14.5'	12'	9.5'	8.5'	8.5'
30	14.5'	12'	8.5'	8.5'	8.5'
40	14.5'	12'	9.5'	8.5'	8.5'
50	14'	12'	9.5'	8.5'	8.5'
65	14'	12'	9'	8'	8'
80	13.5'	11.5'	9'	7.5'	7.5'
100	13'	11'	9'	7.5'	7.5'

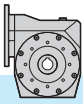

2.6 Carga radial

Carga radial Fr_2 Carga axial Fa_2
en el eje de salida [N]

Si la carga radial en el eje no se aplica a la mitad de la protuberancia del eje, el valor de carga admisible debe evaluarse utilizando la fórmula que se refiere a Fry2, en la cual los valores de a, by Fr_2 se informan en las tablas relativas a cargas radiales

En los ejes con salida doble, cada extremidad puede soportar una carga radial igual a 3/5 del valor de la tabla, siempre y cuando las cargas aplicables sean de igual intensidad y reaccionen en el mismo sentido.

De lo contrario, póngase en contacto con el servicio técnico.

2.6 Radial load

Fr_2 radial loads and Fa_2 axial loads on the output shaft [N]

Should the radial load affect the shaft not at the half-way point of its projection but at a different point, the value of the admissible load has to be calculated using the Fry₂ formula: a, b and Fr₂ values are reported in the radial load tables.

With regard to double-projecting shafts, the load applicable at each end is 2/3 of the value given in the table, on condition that the applied loads feature same intensity and direction and that they act in the same direction.

Otherwise please contact the technical department.

2.6 Charges radiales

Charge radiale Fr_2 Charge axiale Fa_2
sur le puits de sortie [N]

Si la charge radiale sur l'arbre n'est pas appliquée sur la moitié de la saillie de l'arbre, la valeur de charge admissible doit être évaluée à l'aide de la formule faisant référence à Fry2, dans laquelle les valeurs de a, b et Fr_2 sont rapportées dans les tableaux relatifs à charges radiales.

Pour les arbres dépassant des deux côtés qui tournent dans le même sens et à la même vitesse, chaque extrémité devra supporter une charge radiale égale aux 3/5 des valeurs du tableau.

Sinon, contactez le service technique.

Las cargas radiales que se muestran en las tablas están destinadas a aplicarse en el centro de la extensión del eje y se refieren a las cajas de engranajes que funcionan con el factor de servicio 1.

The radial loads indicated in the chart are considered to be applied at the half-way point of the shaft projection, and refer to gear units operating with service factor 1.

Les charges radiales indiquées dans les tableaux sont destinées à être appliquées au milieu du prolongement d'arbre et font référence à des boîtes de vitesses fonctionnant avec le facteur de service 1.

GHA											
$n_1=1400$ rpm		30		40		50		63		75	
i_n	n_2 [rpm]	a = 64.5 b = 47		a = 81.5 b = 58.5		a = 99 b = 70.5		a = 119.5 b = 90.5		a = 131 b = 97	
		Fr_2	Fa_2	Fr_2	Fa_2	Fr_2	Fa_2	Fr_2	Fa_2	Fr_2	Fa_2
5	280	600	120	750	150	900	180	1050	210	/	/
7.5	187	620	125	850	170	1050	210	1200	240	1500	300
10	140	680	140	950	190	1150	230	1350	270	1700	340
15	93	720	145	1000	200	1250	250	1500	300	1900	380
20	70	750	150	1100	220	1400	280	1650	330	2050	410
25	56	800	160	1200	240	1500	300	1850	370	2250	450
30	47	850	170	1250	250	1650	330	2000	400	2450	490
40	35	900	180	1350	270	1750	350	2150	430	2600	520
50	28	920	185	1450	290	1850	370	2300	460	2800	560
60	23	970	195	1550	310	2000	400	2500	500	3000	600
63	22	1000	200	1600	320	2100	420	2650	530	3200	640
80	17.5	1050	210	1700	340	2250	450	2800	560	3350	670
100	14	1100	220	1800	360	2350	470	2950	590	3550	710

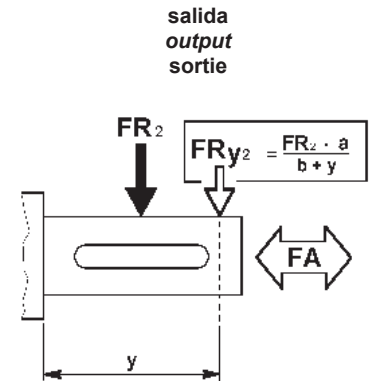

2.7 Sentido de rotación

2.7 Direction of rotation

2.7 Sens de rotation

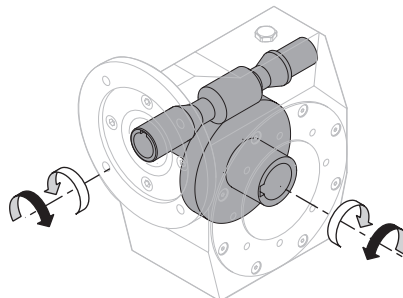

GHA

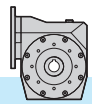

2.8 Lubricación

Los reductores de tornillo sin fin de la serie GHA se suministran con lubricante sintético para uso alimentario: ACEITE FUCHS CASSIDA FLUID 150.

Se recomienda especificar siempre la posición de montaje deseada al realizar el pedido.

Para obtener más detalles, consulte el apartado 1.6 en la pág. 17.

2.8 Lubrication

The GHA series worm gearboxes are supplied complete with synthetic lubricant for food use: FUCHS CASSIDA FLUID 150 OIL.

It is recommended to always specify the desired assembly position when placing the order.

For further details, please see page 17 paragraph 1.6

2.8 Lubrification

Les réducteurs à vis sans fin de la série GHA sont fournis dotés de lubrifiant synthétique à usage alimentaire: HUILE FUCHS CASSIDA FLUID 150.

Toujours préciser la position de montage désirée au moment de la commande.

Pour plus de détails, consulter le paragraphe 1.6 à la page 17.

Posición de montaje

Mounting positions

Positions de montage

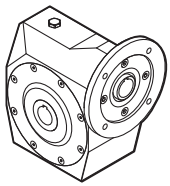

B3

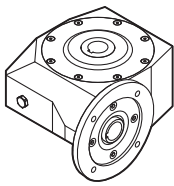

B6

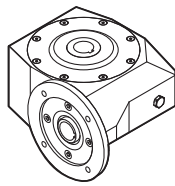

B7

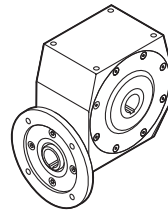

B8

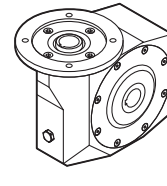

V5

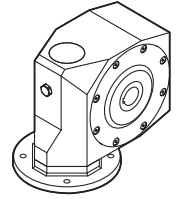

V6

Hay un solo tapón de llenado del aceite.

There is only one filling plug only.

Il n'y a qu'un seul bouchon de remplissage de l'huile.

		Cant. de aceite / Oil quantity / Q.té d'huile [lt]				
		Posizione di montaggio / Mounting position / Positions de montage				
		B3	B6 - B7	B8	V5	V6
GHA	30	0.025	0.040	0.055	0.040	0.040
	40	0.040	0.075	0.100	0.065	0.085
	50	0.085	0.130	0.180	0.125	0.140
	63	0.180	0.260	0.360	0.240	0.290
	75	0.270	0.360	0.450	0.350	0.370

2.9 Posición borne

2.9 Terminal board position

2.9 Position de la boîte à bornes

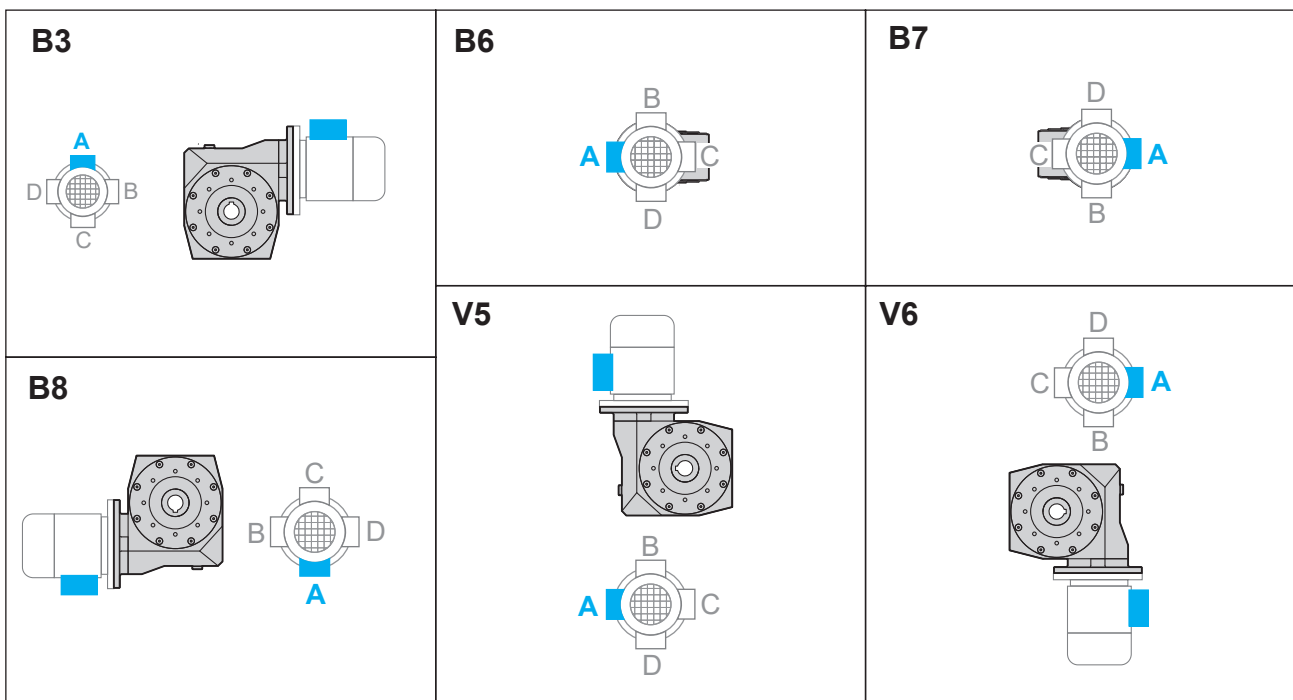

Especificar siempre ordenadamente la posición de montaje y su forma constructiva.

Mounting position always to be specified when ordering.

Lors de toute commande, il est recommandé de préciser la position de montage et la version désirées.

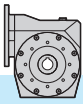

GHA... + MHA... PREMIUM

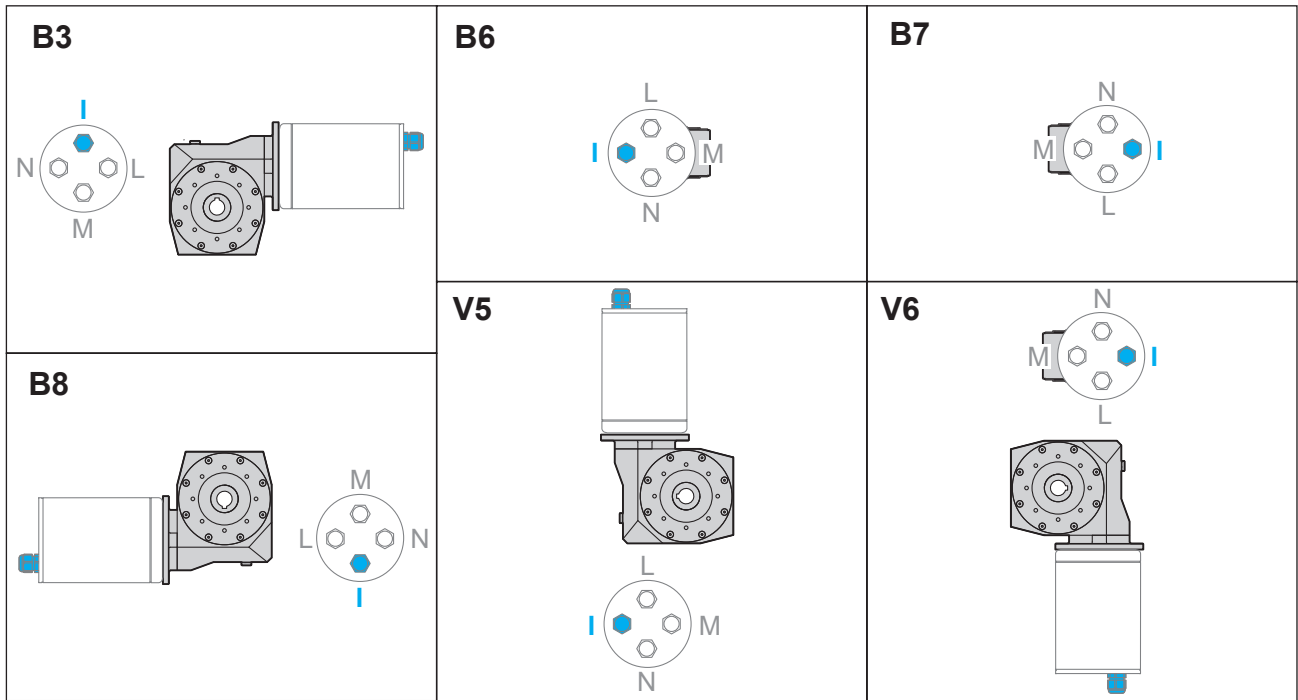

Especificar siempre ordenadamente la posición de montaje y su forma constructiva.

Mounting position always to be specified when ordering.

Lors de toute commande, il est recommandé de préciser la position de montage et la version désirées.

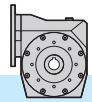

2.11 Datos técnicos

2.11 Technical data

2.11 Données techniques

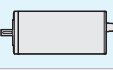
GHA 30	$n_1 = 1400$				MOTORES / MOTORS / MOTEURS								
	i_n	n_2 [min ⁻¹]	Rd	P_{t0}	GHA CLASSIC				MHA PREMIUM				
					T_2 [Nm]	P_1 [kW]	Input IEC B14	FS'	T_2 [Nm]	P_1 [kW]	Input IEC B14		FS'
Kg 1.5	5	280	0.87	0.40	6.5	0.22	63	2.9	5.3	0.18	63	MHA 63 BS	3.6
	7.5	187	0.84	0.40	9	0.22		2.2	7.7	0.18			2.7
	10	140	0.82	0.40	12	0.22		1.8	10	0.18			2.2
	15	93	0.77	0.30	17	0.22		1.3	14	0.18			1.6
	20	70	0.72	0.20	18	0.18		1.1	18	0.18			1.1
	25	56	0.69	0.20	21	0.18		1.0	21	0.18			1.0
	30	47	0.66	0.20	18	0.13	1.1	17	0.13	1.2	MHA 63 AS		
	40	35	0.59	0.20	21	0.13	1.0	21	0.13	1.0			
	50	28	0.55	0.20	17	0.09	1.1	24	0.13	0.8			
	65	22	0.51	0.10	20	0.09	1.0	-	-	-		-	
80	18	0.48	0.10	16	0.06	56	1.0	-	-	-	-	-	
100	14	0.45	0.10	18	0.06		0.8	-	-	-	-	-	

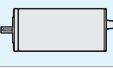
GHA 40	$n_1 = 1400$				MOTORES / MOTORS / MOTEURS								
	i_n	n_2 [min ⁻¹]	Rd	P_{t0}	GHA CLASSIC				MHA PREMIUM				
					T_2 [Nm]	P_1 [kW]	Input IEC B14	FS'	T_2 [Nm]	P_1 [kW]	Input IEC B14		FS'
Kg 2.8	5	280	0.87	0.80	16.3	0.55	71	2.1	11	0.37	71	MHA 71 BS	3.1
	7.5	187	0.85	0.80	24	0.55		1.7	16	0.37			2.5
	10	140	0.83	0.70	31	0.55		1.3	21	0.37			2.0
	15	93	0.79	0.50	30	0.37		1.4	30	0.37			1.4
	20	70	0.76	0.50	38	0.37		1.0	38	0.37			1.1
	25	56	0.72	0.40	31	0.25		1.1	31	0.25			1.2
	30	47	0.68	0.40	35	0.25	1.2	35	0.25	1.2	MHA 71 AS		
	40	35	0.64	0.30	38	0.22	1.0	31	0.18	1.2			
	50	28	0.59	0.30	36	0.18	1.1	36	0.18	1.1			
	65	22	0.54	0.20	31	0.13	63	1.1	30	0.13		1.2	
80	18	0.52	0.20	35	0.13	0.9		36	0.13	0.9			
100	14	0.49	0.20	43	0.13	0.6		43	0.13	0.6			

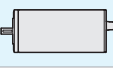
GHA 50	$n_1 = 1400$				MOTORES / MOTORS / MOTEURS								
	i_n	n_2 [min ⁻¹]	Rd	P_{t0}	GHA CLASSIC				MHA PREMIUM				
					T_2 [Nm]	P_1 [kW]	Input IEC B14	FS'	T_2 [Nm]	P_1 [kW]	Input IEC B14		FS'
Kg 4.5	5	280	0.87	1.2	26.7	0.9	80	2.3	22	0.75	80	MHA 80 BS	2.8
	7.5	187	0.86	1.2	40	0.9		1.8	33	0.75			2.1
	10	140	0.84	1.0	52	0.9		1.4	43	0.75			1.7
	15	93	0.80	0.80	74	0.9		1.0	62	0.75			1.2
	20	70	0.78	0.70	58	0.55		1.3	53	0.5			1.4
	25	56	0.74	0.60	47	0.37		1.4	63	0.5			1.0
	30	47	0.71	0.60	53	0.37	1.2	53	0.37	1.2	MHA 80 AS		
	40	35	0.67	0.50	68	0.37	1.0	68	0.37	1.0			
	50	28	0.62	0.40	53	0.25	71	1.3	53	0.25		1.3	
	65	22	0.58	0.40	64	0.25		1.0	63	0.25		1.0	
80	18	0.54	0.40	71	0.25	0.8		52	0.18	1.1			
100	14	0.51	0.30	86	0.25	0.6		45	0.13	1.2			

* **ATENCIÓN:** el par máximo utilizable [T_{2M}] deberá calcularse con respecto al factor de servicio: $T_{2M} = T_2 \times FS'$

* **WARNING:** Maximum allowable torque [T_{2M}] must be calculated using the following service factor: $T_{2M} = T_2 \times FS'$

* **ATTENTION :** le couple maximum admissible [T_{2M}] se calcule en utilisant le facteur de service suivant : $T_{2M} = T_2 \times FS'$

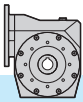

2.11 Datos técnicos

2.11 Technical data

2.11 Données techniques

GHA 63	$n_1 = 1400$				MOTORES / MOTORS / MOTEURS								
	i_n	n_2 [min ⁻¹]	Rd	P_{t0}	GHA CLASSIC				MHA PREMIUM				
					T_2 [Nm]	P_1 [kW]	Input IEC B14	FS'	T_2 [Nm]	P_1 [kW]	Input IEC B14		FS'
Kg 7.8	5	280	0.88	1.8	54	1.8	90	2.0	45	1.5	90	MHA 90 BS	2.5
	7.5	187	0.87	1.8	80	1.8		1.5	67	1.5			1.8
	10	140	0.85	1.6	105	1.8		1.2	87	1.5			1.5
	15	93	0.81	1.2	125	1.5		1.1	125	1.5			1.1
	20	70	0.80	1.2	120	1.1		1.2	120	1.1			1.2
	25	56	0.77	1.0	118	0.9	1.0	98	0.75	1.2	MHA 90 AS	1.2	
	30	47	0.73	0.90	134	0.9	1.1	111	0.75	1.3			
	40	35	0.69	0.80	142	0.75	1.1	141	0.75	1.1	MHA 80 BS	1.1	
	50	28	0.65	0.70	122	0.55	1.0	111	0.5	1.1			
	65	22	0.61	0.60	145	0.55	0.8	98	0.37	1.2	MHA 80 AS	1.2	
80	18	0.58	0.60	169	0.55	0.6	113	0.37	1.0				
100	14	0.53	0.50	198	0.55	0.5	90	0.25	1.1	MHA 71 BM	1.0		
											MHA 71 AM	1.1	

GHA 75	$n_1 = 1400$				MOTORES / MOTORS / MOTEURS									
	i_n	n_2 [min ⁻¹]	Rd	P_{t0}	GHA CLASSIC				MHA PREMIUM					
					T_2 [Nm]	P_1 [kW]	Input IEC B14	FS'	T_2 [Nm]	P_1 [kW]	Input IEC B14		FS'	
Kg 12.8	7.5	187	0.87	2.5	80	1.8	90	2.7	67	1.5	90	MHA 90 BS	2.7	
	10	140	0.86	2.3	106	1.8		1.8	88	1.5			2.2	
	15	93	0.83	1.9	153	1.8		1.3	128	1.5			1.6	
	20	70	0.81	1.7	199	1.8		1.1	166	1.5			1.3	
	25	56	0.78	1.5	200	1.5		1.0	200	1.5			1.0	
	30	47	0.74	1.2	167	1.1		1.3	165	1.1		1.4	MHA 90 AS	1.4
	40	35	0.71	1.1	213	1.1		1.1	213	1.1		1.1		
	50	28	0.67	1.0	251	1.1		0.8	171	0.75		1.2	MHA 80 BM	1.2
	65	22	0.63	0.90	300	1.1		0.6	137	0.5		1.4	MHA 80 AM	1.4
	80	18	0.60	0.80	350	1.1		0.5	159	0.5		1.1		
100	14	0.56	0.70	420	1.1	0.4	191	0.5	0.9					

* **ATENCIÓN:** el par máximo utilizable [T_{2M}] deberá calcularse con respecto al factor de servicio: $T_{2M} = T_2 \times FS'$

* **WARNING:** Maximum allowable torque [T_{2M}] must be calculated using the following service factor: $T_{2M} = T_2 \times FS'$

* **ATTENTION :** le couple maximum admissible [T_{2M}] se calcule en utilisant le facteur de service suivant : $T_{2M} = T_2 \times FS'$

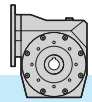



2.12 **Momento de inercia** [Kg·cm²]
(referido al eje rápido de entrada)

2.12 **Moments of inertia** [Kg·cm²]
(referred to input shaft)

2.12 **Moments d'inertie** [Kg·cm²]
(se rapportant à l'arbre d'entrée)

GHA 30	i _n		
		B14	
		IEC 56	IEC 63
5	0.130	0.127	
7.5	0.112	0.109	
10	0.103	0.100	
15	0.097	0.094	
20	0.095	0.092	
25	0.094	0.091	
30	0.093	0.090	
40	0.093	0.090	
50	0.092	0.089	
65	0.079	-	
80	0.079	-	
100	0.078	-	

GHA 63	i _n		
		B14	
		IEC 80	IEC 90
5	2.431	2.671	
7.5	1.949	2.269	
10	1.744	2.063	
15	1.597	1.916	
20	1.545	1.864	
25	1.514	1.833	
30	1.508	1.828	
40	1.495	-	
50	1.488	-	
65	1.484	-	
80	1.482	-	
100	1.481	-	

GHA 40	i _n		
		B14	
		IEC 63	IEC 71
5	0.391	0.463	
7.5	0.321	0.356	
10	0.272	0.347	
15	0.266	0.340	
20	0.263	0.338	
25	0.262	0.337	
30	0.262	0.337	
40	0.261	0.336	
50	0.261	-	
65	0.261	-	
80	0.261	-	
100	0.261	-	

GHA 75	i _n		
		B14	
		IEC 90	
7.5	3.712		
10	3.234		
15	2.893		
20	2.774		
25	2.709		
30	2.689		
40	2.659		
50	2.642		
65	2.633		
80	2.629		
100	2.626		

GHA 50	i _n		
		B14	
		IEC 71	IEC 80
5	0.922	1.046	
7.5	0.684	0.935	
10	0.602	0.853	
15	0.543	0.794	
20	0.523	0.774	
25	0.513	0.764	
30	0.508	0.759	
40	0.503	0.755	
50	0.501	-	
65	0.499	-	
80	0.498	-	
100	0.498	-	

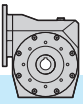

2.13 Tamaño

2.13 Dimensions

2.13 Dimensions

GHA.. PP

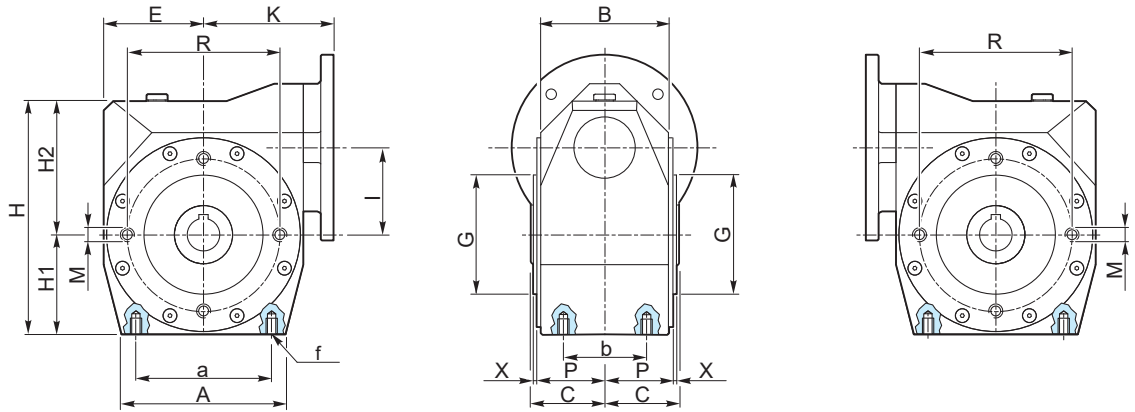

GHA.. CC

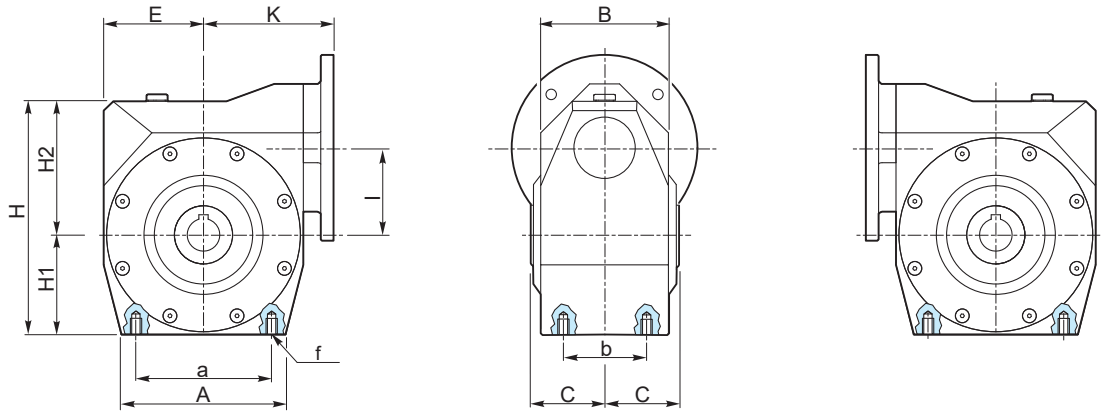

GHA.. PD

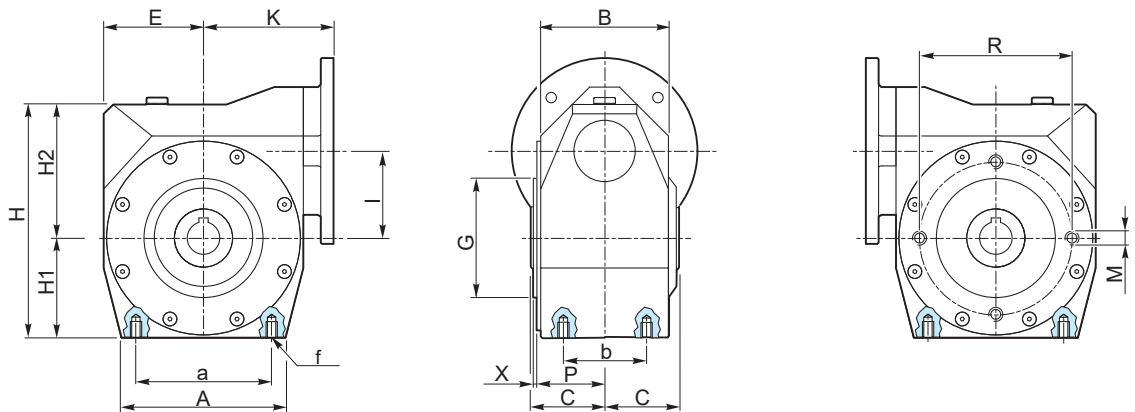

GHA.. PS

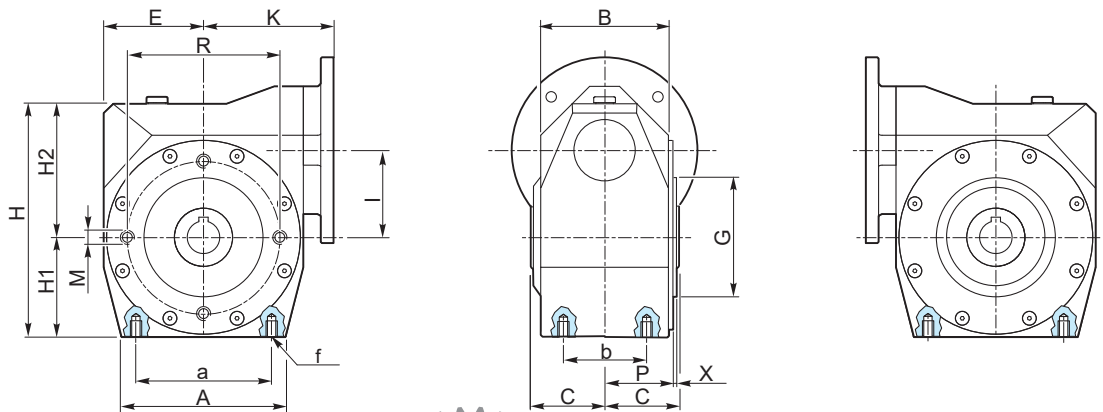

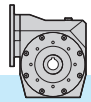

2.13 Tamaño

2.13 Dimensions

2.13 Dimensions

Brida pendular / Shaft-mounted flange / Bride pendulaire

30

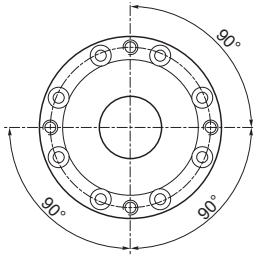

4 Agujeros / Holes / Trous

40 - 50

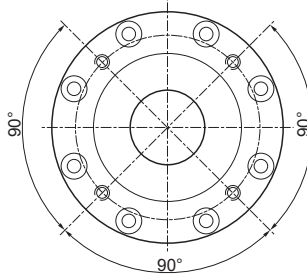

4 Agujeros / Holes / Trous

63 - 75 - 89

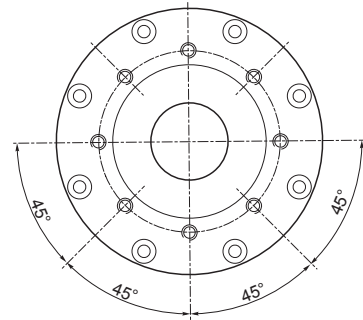

8 Agujeros / Holes / Trous

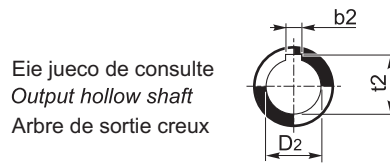

GHA	A	a	B	b	b ₂	C	D ₂ H8	E	f	G h8	H	H ₁	H ₂
30	66	54	56	44	5	31.5	14	40	M6 x 9	55	93	40	53
40	85	70	71	60	6	39	18	50	M6 x 11	60	116	50	66
50	95	80	84	70	8	46	25	60	M8 x 12	70	142	60	82
63	118	100	101	85	8	56	25	72	M8 x 16	80	173	72	101
75	142	120	110	90	8	60	28	86	M10 x 16	95	201	86	115

GHA	I	K	M	P	R	t ₂	X	
30	31.5	57	M6x8	29	65	16.3	1.5	1.5
40	40	75	M6X10	36.5	75	20.8	1.5	2.8
50	50	82	M8x10	43.5	85	28.3	1.5	4.5
63	63	96.8	M8x14	53	95	28.3	2	7.8
75	75	112	M8x14	57	115	31.3	2	12.8

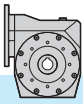

GHA.. + MHA PREMIUM

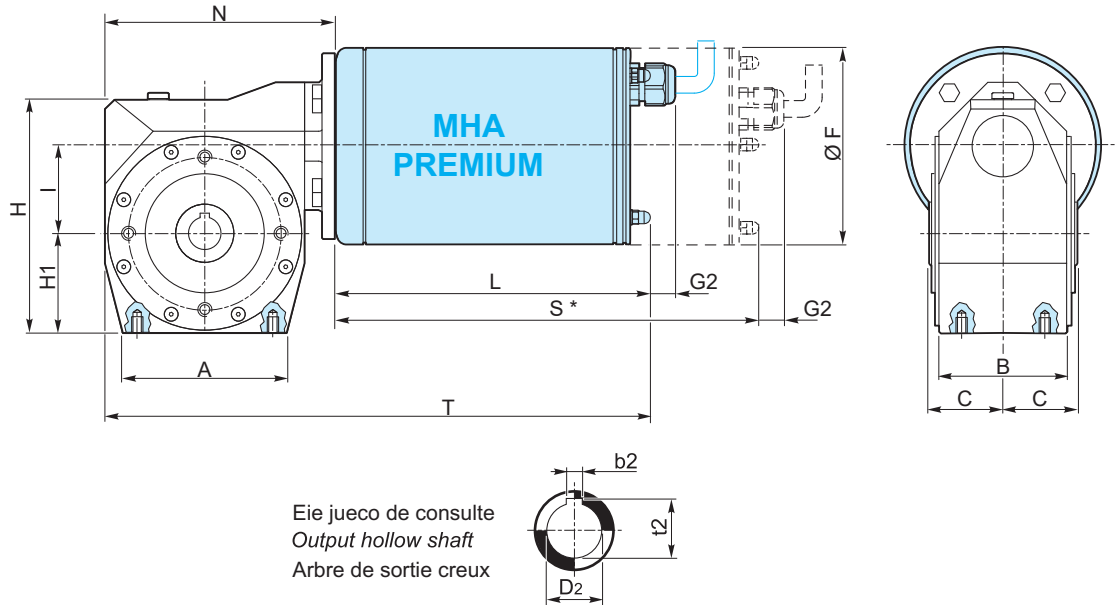

GHA	A	B	b ₂	C	D ₂ H8	H	H ₁	I	t ₂	N
30	66	56	5	31.5	14	93	40	31.5	16.3	97
40	85	71	6	39	18	116	50	40	20.8	125
50	95	85	8	46	25	142	60	50	28.3	148
63	118	103	8	56	25	173	72	63	28.3	168.8
75	142	112	8	60	28	201	86	75	31.3	198

GHA... + MHA... PREMIUM											
GHA	GHA 30	GHA 40		GHA 50			GHA 63		GHA 75		
IEC B14	63	63	71	71		80	80		90		
MHA	MHA63		MHA71	MHA63	MHA71	MHA80	MHA71	MHA80	MHA90	MHA80	MHA90
F	Ø118		Ø134	Ø118	Ø134	Ø150	Ø134	Ø150	Ø190	Ø150	Ø190
L	235		246	235	246	271	246	271	339	271	339
G2	16 (con prensaestopos estándar / with standard cable gland / avec presse-étoupe ordinaire)										
T	332	360	371	383	394	419	414.8	439.8	507.8	469	537
	10.3	11.6	15.8	13.3	17.5	22.5	20.8	25.8	32.8	30.8	37.8
	0.13 kW	0.13 kW	0.25 kW	0.13 kW	0.25 kW	0.50 kW	0.25 kW	0.50 kW	1.1 kW	0.50 kW	1.1 kW
	11	12.3	17.3	14.0	19.0	23.5	22.3	26.8	39.8	31.8	44.8
	0.18 kW	0.18 kW	0.37 kW	0.18 kW	0.37 kW	0.75 kW	0.37 kW	0.75 kW	1.5 kW	0.75 kW	1.5 kW

*S: cota válida solo para las versiones bajo pedido (freno, codificador, etc.).

*S: value valid only for the versions on request (brake, encoder, ecc.).

*S: cote valable uniquement pour les versions sur demande (frein, codeur, etc.).

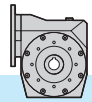

2.13 Tamaño

2.13 Dimensions

2.13 Dimensions

Brida entrada / Input flange / Bride d'entrée

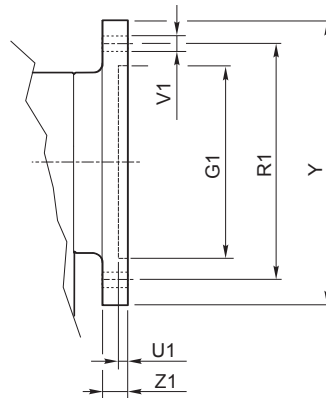
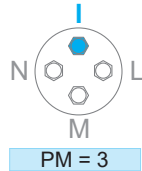
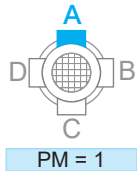

GHA	IEC	G ₁	R ₁	U ₁	V ₁		Y	Z ₁	Diámetro orificios PAM / Holes diameter IEC / Diamètres trous PAM												
					∅				5	7.5	10	15	20	25	30	40	50	65	80	100	
30	56 B14	50	65	3.5	6	4	80	8	9	9	9	9	9	9	9	9	9	9	9	9	9
	63 B14	60	75	4	6	4	90	8	11	11	11	11	11	11	11	11	11	11	/	/	/
40	63 B14	60	75	3.5	6	4	90	8	11	11	11	11	11	11	11	11	11	11	11	11	11
	71 B14	70	85	3.5	7	4	105	8	14	14	14	14	14	14	14	14	14	/	/	/	/
50	71 B14	70	85	3.5	7	4	105	8	14	14	14	14	14	14	14	14	14	14	14	14	14
	80 B14	80	100	4	7	4	120	10	19	19	19	19	19	19	19	19	19	/	/	/	/
63	80 B14	80	100	4	7	4	120	10	19	19	19	19	19	19	19	19	19	19	19	19	19
	90 B14	95	115	4	8.5	4	140	10	24	24	24	24	24	24	24	24	/	/	/	/	/
75	90 B14	95	115	4	9	4	140	11	/	24	24	24	24	24	24	24	24	24	24	24	24

Nota: el montaje STD de P_M=1. Para el motor MHA PREMIUM, montaje STD de P_M=3.

N.B.: STD mounting of P_M=1. In the case of the MHA PREMIUM motor, STD assembly of P_M=3.

N.B.: Montage STD de P_M=1. En cas de moteur MHA PREMIUM, montage STD de P_M=3.

2.10 Accesorios

2.10 Accessoires

2.14 Accesorios (Brazo de reacción)

2.14 Accessories (Torque arm)

2.14 Accessoires (Bras de réaction)

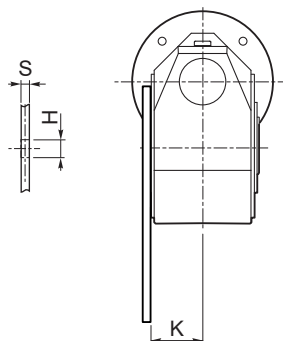
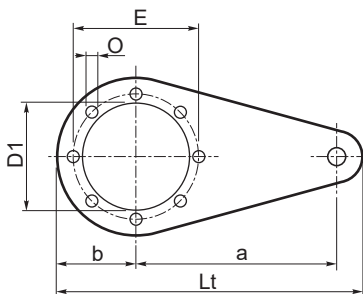

GHA	a	b	D ₁	E	H	K	L _t	O	S
30	85	37	55	65	8	29	138	6.5 n°4	5
40	100	47	60	75	10	36.5	167	7 n°4	5
50	100	57.5	70	85	10	43.5	179	9 n°4	5
63	150	55	80	95	10	53	227	9 n°8	6
75	200	67	95	115	20	57	299	9 n°8	6

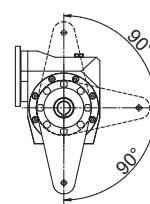

30 - 40 - 50

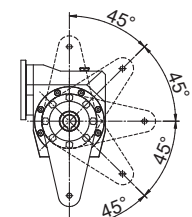

63 - 75 - 89

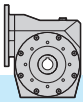

2.15 Lista de recambios

2.15 Spare parts list

2.15 Liste des pièces détachées

Cuando se ordene un recambio, especificar siempre el número particular de cada pieza referenciado en el despiece (ver gráfico de despiece) fecha (1), n° de código (2) y n° variable (3).
(Ver placa de características).

When ordering please specify the spare part number (see exploded view) as well as the date (1), the article number (2) and the variant number (3) (see plate).

Lors de la commande de pièces détachées, toujours rappeler le n° de la pièce (voir plan éclaté), la date (1), le n° de code (2) et le n° de la variante (3).
(Voir plaquette signalétique).

CODIGO: Lista de componentes

CODE: Base list

CODE: Liste du matériel

TIPO: descripción

TYPE: description

TYPE: description

RAP: relación de reducción

RATIO: reduction ratio

RAP : rapport de réduction

VARIANTE:

código alfanumérico

MODEL:

alphanumeric code

VARIANTE:

code alpha numérique

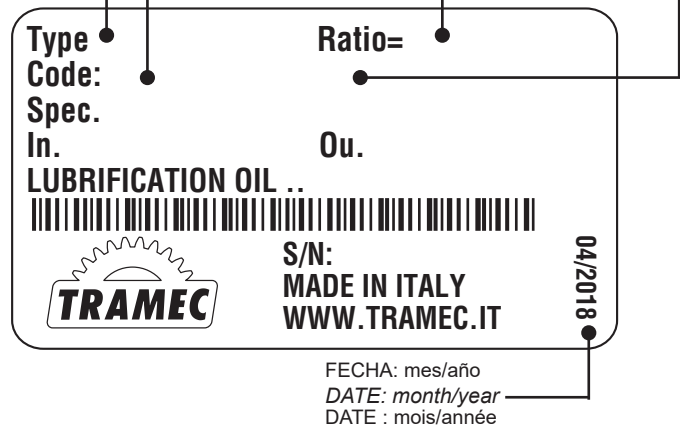

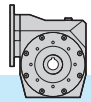

GHA

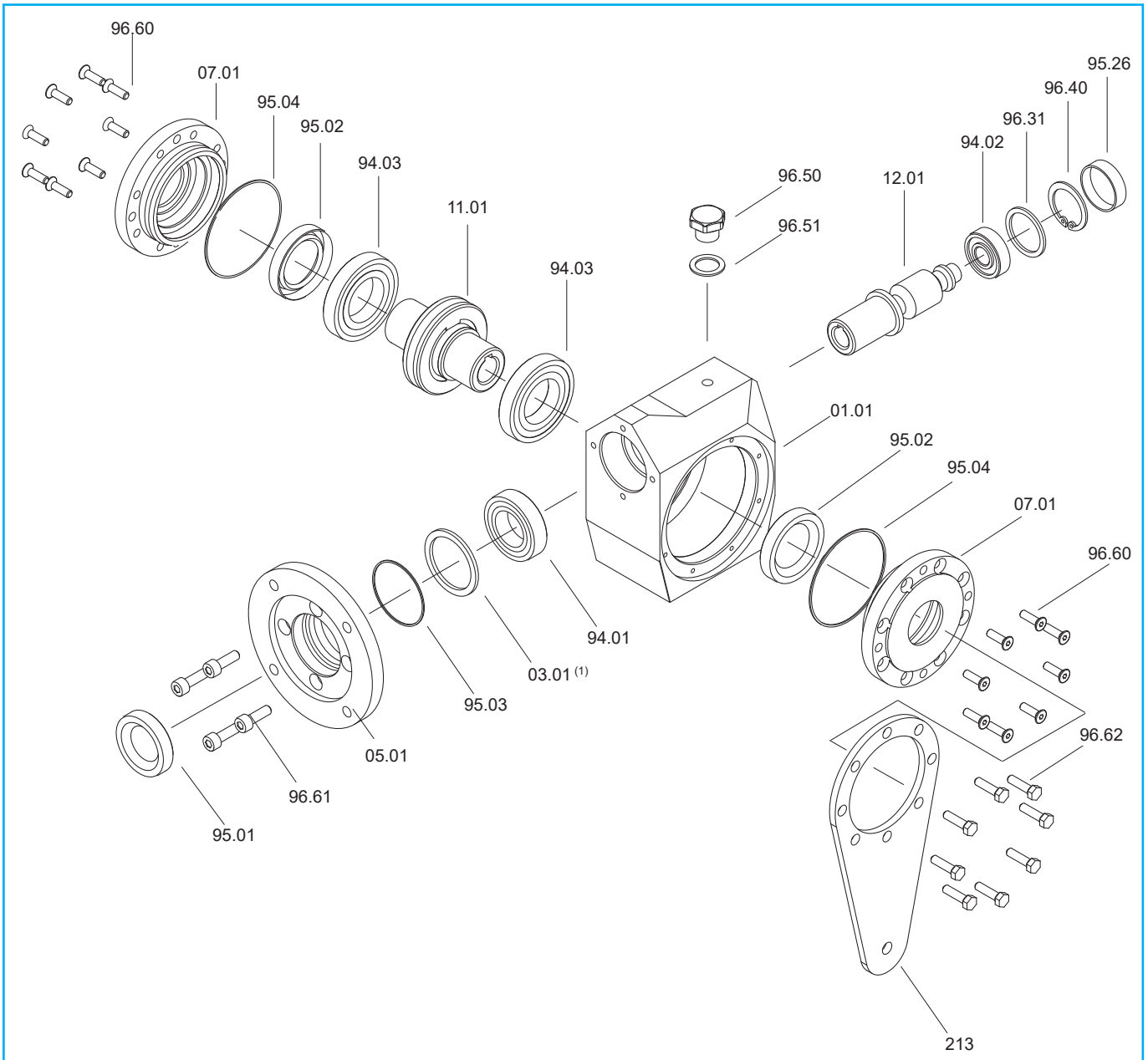

GHA	IEC	Rodamientos / Bearings / Roulements			Retenes / Oilseals / Bagues d'étanchéité		OR		Casquete / Closed oil seal / Capot
		94.01	94.02	94.03	95.01	95.02	95.03	95.04	95.26
30	56	61904 (20x37x9)	6000 (10x26x8)	16005 (25x47x8)	20/35/7	25/40/7	33x1.2	50x1.5	ø 26x7
	63								
40	63	6204 (20x47x14)	6201 (12x32x10)	16006 (30x55x9)	20/47/7	30/47/7	43x1.5	65x2	ø 32x7
	71	6005 (25x47x12)			25/47/7				
50	71	6005 (25x47x12)	6203 (17x40x12)	16008 (40x68x9)	25/47/7	40/62/8	50x1.5	82x2	ø 40x7
	80	6006 (30x55x13)			30/47/7				
63	80	6206 (30x62x16)	6204 C3 (20x47x14)	16008 (40x68x9)	30/62/7	40/62/8	56x1.5	102x2.5	ø 47x7
	90	6007 (35x62x14)			35/62/7				
75	90	6007 (35x62x14)	6205 C3 (25x52x15)	16010 (50x80x10)	35/62/7	50/72/8	60x3	123x3	ø 52x7

(1) Solo para GHA 63 PAM90 e 75 PAM 90 e 100 / Only for GHA 63 PAM 90 and 75 PAM 90 and 100 / Uniquement pour GHA 63 PAM 90, 75 PAM 90 und 100

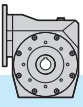

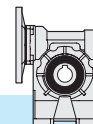

3.0 REDUCTORES TORNILLO SIN FIN GK GK WORM GEARBOXES RÉDUCTEUR À ROUE ET VIS SANS FIN GK

3.1	Características	<i>Characteristics</i>	Caractéristiques	40
3.2	Nomenclatura	<i>Designation</i>	Désignation	41
3.3	Rendimiento	<i>Efficiency</i>	Rendement	42
3.4	Irreversibilidad	<i>Irreversibility</i>	Irréversibilité	42
3.5	Juego angular	<i>Backlash</i>	Jeu d'angle	43
3.6	Cargas radiales	<i>Radial load</i>	Charges radiales	44
3.7	Sentido de rotación	<i>Direction of rotation</i>	Sens de rotation	44
3.8	Lubricación y posición de montaje	<i>Lubrication and mounting position</i>	Lubrification et positions de montage	45
3.9	Posición del tablero de Borne	<i>Terminal board position</i>	Position de la boîte à bornes	45
3.10	Datos técnicos	<i>Technical data</i>	Données techniques	46
3.11	Momento de inercia	<i>Moments of inertia</i>	Momento de inercia	52
3.12	Tamaño	<i>Dimensions</i>	Dimensions	45
3.13	Entrada suplementaria	<i>Additional input</i>	Entrée supplémentaire	56
3.14	Accesorios	<i>Accessories</i>	Accessoires	56
3.15	Lista de recambios	<i>Spare parts list</i>	Liste des pièces détachées	56

GHA - CLASSIC

La serie CLASSIC es la serie estándar dentro de la gama de reductores GHA.

Las especiales características NANOTECNOLÓGICAS del revestimiento de la carcasa y su diseño externo permiten que los reductores de esta serie sean especialmente aptos para las aplicaciones en ambientes de la industria ALIMENTARIA y FARMACÉUTICA.

A pesar de que los reductores de la serie GHA CLASSIC están certificados como dispositivos adecuados para utilizarse en máquinas alimentarias y, por lo tanto, para aplicaciones en plantas de producción y manipulación de alimentos, no están certificados para utilizarse en contacto con alimentos.

GHA - CLASSIC

The CLASSIC series is the standard series within the range of GHA gearboxes.

The special NANOTECHNOLOGICAL properties of the case coating and its external construction, certified by HACCP, make the gearboxes of this series particularly suitable for applications in FOOD and PHARMACEUTICAL environments.

Although the GHA CLASSIC series reducers are certified as suitable devices for use on food processing machines and therefore for applications that operate in food production and handling plants, they are not certified for use in contact with food.

GHA - CLASSIC

La série CLASSIC constitue la série standard au sein de la gamme de réducteurs GHA.

Grâce aux caractéristiques spéciales NANOTECHNOLOGIQUES du revêtement de la carcasse et à leur design externe, les réducteurs de cette série conviennent tout particulièrement aux applications dans les environnements ALIMENTAIRE, PHARMACEUTIQUE.

Bien que les réducteurs de la série GHA CLASSIC soient certifiés en tant que dispositifs adaptés à l'utilisation sur des machines alimentaires et donc pour des applications qui opèrent dans des usines de production et de manipulation des aliments, ils ne sont pas certifiés pour l'utilisation au contact des aliments.

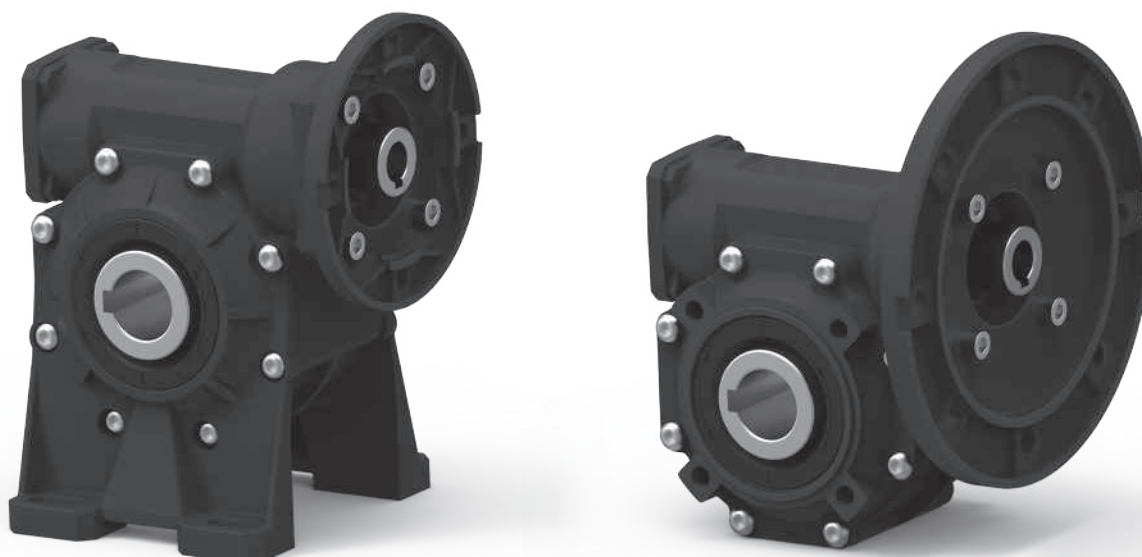

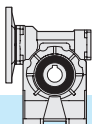

3.1 Características

- Los reductores de la serie con tornillo sin fin GK son muy ligeros gracias a la carcasa compacta, para todos los tamaños.
- La carcasa y las bridas de aleación de aluminio fundido a presión son arenadas y tratadas con la tecnología G.H.A.
- La serie cuenta con variadas versiones, con y sin pies, lo que la hace más versátil para su uso en cualquier tipo de aplicación.
- La serie GK se encuentra disponible exclusivamente en la versión preparada para la conexión del motor (PAM) y sin eje de entrada macho.
- El tornillo sin fin es de acero aleado cementado-templado y rectificado.
- La corona tiene un buje de acero inoxidable AISI 316 y un anillo dentado de bronce GCuSn12.
- Equipados con eje hueco de acero inoxidable AISI 316, pernos de acero inoxidable, juntas de material certificado por la FDA y lubricantes para la industria alimentaria (categoría de certificación NSF H1).
- Para aplicaciones en el sector marítimo (M), no se utilizan lubricantes NSF H1 ni anillos de estanqueidad de material certificado por la FDA.
- El eje hueco de salida se suministra de serie y hay una amplia gama de accesorios disponibles: segunda entrada (no es de acero inoxidable), brida de salida y brazo de reacción (en aleación de aluminio con tratamiento G.H.A. y montado con tornillos de acero inoxidable).

3.1 Characteristics

- *The GK worm gear series reducers are extremely lightweight thanks to the compact shape of the casing for all sizes.*
- *The casing and flanges in die-cast aluminium alloy are sandblasted and treated with G.H.A technology.*
- *The series features a wide range of versions, with and without feet, which make it more versatile for use in all types of applications.*
- *The GK series is only available in the version designed for motor coupling (PAM) and not with a male input shaft.*
- *The worm gear is made of cemented-tempered alloy steel and is ground.*
- *The crown wheel features an AISI 316 stainless steel hub and a GCuSn12 bronze toothed ring.*
- *Equipped with an AISI 316 stainless steel hollow shaft, seals made of FDA-certified material and lubricants for the food industry (NSF H1 certification category).*
- *For applications in the marine sector (M), NSF H1 lubricants and FDA-certified sealing rings are not used.*
- *The hollow output shaft is supplied as standard and there is a wide range of accessories available: second inlet (not in stainless steel), outlet flange and reaction arm (in aluminium alloy with G.H.A treatment and mounted with stainless steel screws)*

3.1 Caractéristiques

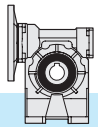

- Les réducteurs de la série à vis sans fin GK sont extrêmement légers grâce à la forme compacte de leur carcasse, pour toutes les tailles.
- La carcasse et les brides en alliage d'aluminium moulé sous pression sont sablées et traitées avec la technologie G.H.A.
- La série possède de nombreuses versions, avec ou sans pieds, qui lui confèrent une plus grande polyvalence d'utilisation dans chaque type d'application.
- La série GK n'est disponible que dans la version prévue pour la fixation du moteur (PAM) et non pas avec un arbre d'entrée mâle.
- La vis sans fin, réalisée en acier allié cimenté-trempé, est rectifiée.
- Le moyeu de la couronne est en acier INOX AISI 316 et l'anneau denté en bronze GCuSn12.
- Pourvus d'un arbre creux en INOX AISI 316, de boulons en INOX, de joints d'étanchéité réalisés dans un matériau certifié FDA et de lubrifiants pour l'industrie alimentaire (catégorie de certification NSF H1).
- Pour les applications dans le secteur marin (M), les lubrifiants NSF H1 et joints d'étanchéité en matériau certifié FDA ne sont pas utilisés.
- L'arbre de sortie creux est fourni de série et une large gamme d'accessoires est disponible : deuxième entrée (en acier non INOX), bride de sortie et bras de réaction (en alliage d'aluminium avec traitement G.H.A. et monté avec des vis en acier INOX).



3.2 Nomenclatura

3.2 Designation

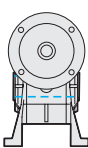
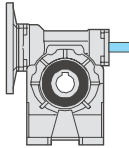
3.2 Désignation

Reductores Gearbox Réducteur	Tipo entrada Input type Type d'entrée	Grandezza Size Größe	Versión Version Version	Relación redu. Ratio Rapport de réduction	Enganche motor. Motor coupling montage moteur	Posición montaje Mounting position Position Montage	eje de salida de cable Hollow output shaft arbre de sortie de câble	Segunda entrada Additional input Deuxième entrée	Brazo de reacción Torque arm Bras de réaction	Campo de aplicación Field of application Domaine d'application
GK	C	50	F1S	10	P.A.M	B3	H25	SeA	BR	A
Reductores de tornillo sin fin Wormgearbox Réducteur à roue et vis sans fin		30 40 50 63 75 89	A1-A2 B1-B2 V1-V2 P F1S-F2S F3S F1D-F2D F3D	5 7.5 10 15 20 25 30 40 50 65 80 100	56 63 71 80 90 100 112	B3 B6 B7 B8 V5 V6	 H..	 SeA	 BR	A Alimentario y farmacéutico Food and Pharmaceutical Alimentaire et Pharmaceutique M * Marítimo Marine Marin

*: a petición

*: on request

*: sur demande

Versión

Versions

Versions

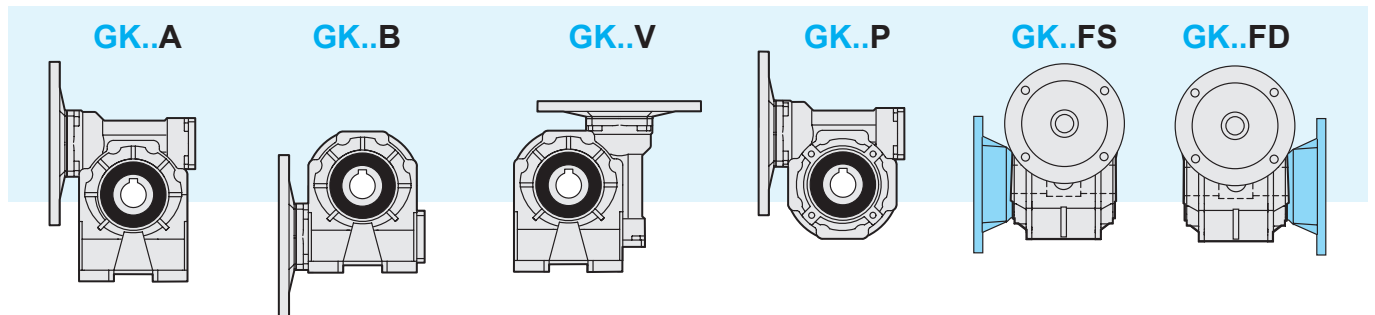

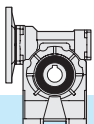

3.3 Rendimiento

Rd - Es el rendimiento dinámico, definido como la relación entre la potencia de salida P_2 y aquella con entrada P_1 . Este depende principalmente de la velocidad de roce, del tipo de lubricante y de la angulación del tornillo. Los valores indicados en las tablas son válidos si se aplica el correspondiente par en salida. Durante la fase de rodaje, aproximadamente las primeras 300 horas de funcionamiento bajo carga, el valor debe ser considerado inferior al 30% respecto al indicado en la tabla.

Rs - Es el rendimiento estático que se obtiene al arrancar el reductor y varía en base a la relación de reducción. Para una correcta elección del reductor a emplear, es importante en las aplicaciones en las cuales no se alcanzan nunca las condiciones de régimen como en los funcionamientos intermitentes. De forma análoga al caso dinámico, también el rendimiento estático durante el rodaje es inferior al 30% respecto al valor indicado en la tabla.

3.3 Efficiency

Rd - dynamic efficiency, defined as the ratio between P_2 output power and P_1 input power. It mainly depends on the slipping speed, the type of lubricant and the lead angle. The values reported in the table are valid when the corresponding output torque is applied. During the first 300 operating hours under load, the value to be considered is 30% lower than that reported in the table.

Rs - static efficiency at gearbox start-up; it changes depending on the reduction ratio. Rs value is important for selecting the right gearbox for applications where a steady state is never achieved, as for intermittent duty applications. Same as dynamic efficiency, static efficiency too during the running-in period will be 30% lower than the value reported in the table.

3.3 Rendement

Rd - Le rendement dynamique est le rapport entre la puissance de sortie P_2 et la puissance d'entrée P_1 . Le rendement dépend principalement de la vitesse de glissement, du type de lubrification et de l'angle d'hélice. Les valeurs indiquées dans les tableaux sont valables si l'on applique le couple correspondant à la sortie. En phase de rodage, qui représente environ les 300 premières heures de fonctionnement à pleine charge, la valeur doit être considérée comme étant inférieure de 30% à celle indiquée dans le tableau.

Rs - Il s'agit du rendement statique au démarrage du réducteur. Il varie en fonction du rapport de réduction. Le Rs est donc important pour choisir le réducteur à utiliser, surtout pour des applications où les conditions de régime ne sont jamais optimales, comme par exemple dans des applications à charges intermittentes. Comme pour le cas dynamique, le rendement statique durant le rodage est lui aussi inférieur de 30% par rapport à la valeur indiquée dans le tableau.

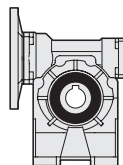

GK	Rs											
	5	7.5	10	15	20	25	30	40	50	65	80	100
30	0.70	0.67	0.62	0.55	0.47	0.43	0.39	0.30	0.27	0.25	0.22	0.21
40	0.69	0.67	0.63	0.55	0.52	0.45	0.40	0.35	0.29	0.26	0.25	0.23
50	0.69	0.68	0.65	0.58	0.53	0.47	0.41	0.37	0.32	0.28	0.25	0.23
63	0.70	0.68	0.65	0.57	0.55	0.50	0.47	0.38	0.33	0.29	0.28	0.23
75	/	0.68	0.65	0.58	0.55	0.51	0.43	0.39	0.35	0.31	0.28	0.24
89	/	0.68	0.65	0.58	0.55	0.52	0.45	0.39	0.36	0.32	0.29	0.25

3.4 Irreversibilidad

En las aplicaciones donde sea necesario evitar la transmisión del movimiento reaccionario o sostener la carga, en ausencia de la alimentación eléctrica, es aconsejable adaptar frenos externos.

En los reductores de tornillo sin fin aparece esta característica natural, denominada grado de irreversibilidad, que crece al aumentar la relación de reducción por estar estrechamente ligado al relativo rendimiento.

Para obtener altos grados de irreversibilidad es necesario adoptar las relaciones de reducción más altas, sin olvidar que el rendimiento tiende a crecer durante las primeras 500 horas de funcionamiento estabilizándose después en los valores indicados en el catálogo.

Irreversibilidad estática

Condiciones para impedir la rotación, comandado por el eje lento, sin excluir posibles retornos lentos en el caso que la carga sea sometida a vibraciones.

Rs < 0.45 se tiene irreversibilidad
Rs = 0.45 ÷ 0.55 irreversibilidad incierta
Rs > 0.55 se tiene reversibilidad

3.4 Irreversibility

The use of external brakes is advised in case of applications where backwards motion must be hindered and the load must be held should the feed be cut off.

Some worm gearboxes feature natural irreversibility. The higher the ratio, the higher is the irreversibility, since it is strictly dependent on the relative efficiency.

In order to achieve high irreversibility it is therefore necessary to select higher efficiency reduction ratios not to forget that the efficiency is growing during the first 500 hours life until it stabilizes to the values mentioned in the catalogue.

Static irreversibility

Static irreversibility occurs when the rotation controlled by the output shaft is hindered; possible slow returns cannot be excluded should the load be subject to vibrations.

Rs < 0.45 provides irreversibility
Rs = 0.45 ÷ 0.55 irreversibility is uncertain
Rs > 0.55 reversibility is possible

3.4 Irréversibilité

En cas d'absence d'alimentation électrique, il est conseillé de choisir des freins extérieurs pour les applications où il faut éviter la transmission du mouvement rétrograde ou bien soutenir la charge.

Le degré d'irréversibilité est une caractéristique naturelle des réducteurs à roue et vis sans fin. Elle augmente en même temps que le rapport de réduction puisqu'elle est liée au rendement.

Pour obtenir d'importants degrés d'irréversibilité, il faut donc utiliser des rapports de réductions plus élevés, sans oublier que le rendement tend à augmenter au bout des 500 premières heures de service pour se stabiliser par la suite aux valeurs mentionnées sur le catalogue.

Irréversibilité statique

Condition qui empêche la rotation commandée par l'arbre de sortie. D'éventuels retours lents ne sont pas à exclure si la charge est soumise à des vibrations.

Rs < 0.45 produit une irréversibilité
Rs = 0.45 ÷ 0.55 irréversibilité incertaine
Rs > 0.55 réversibilité possible

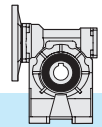

Irreversibilidad dinámica

Condición de detención por lo tanto el soporte de la carga en el momento en que se suspende la acción de comando. La condición es más difícil de obtener cuando es influenciada por el rendimiento dinámico, la velocidad de rotación, posibles vibraciones que la carga puede generar y por la dirección del movimiento en relación de la carga.

Esta última condición es muy evidente en los elevadores: una carga en ascenso, suspendida la acción de comando, debe pararse y asumir una velocidad cero (rendimiento estático) antes de invertir el movimiento y caer por gravedad.

Una carga en descenso, en cambio, tiende a continuar en su movimiento obstruido en caída, por el rendimiento dinámico.

Rd < 0.45 se tiene irreversibilidad
Rd = 0.45 ÷ 0.55 irreversibilidad incierta
Rd > 0.55 se tiene reversibilidad

Dynamic irreversibility

Dynamic irreversibility is characterized by stillstand and hold of the load when the drive stops. It is more difficult to achieve this condition because it is influenced by dynamic efficiency, speed of rotation and possible vibrations generated by the motion direction with regard to the load.

This last condition is much more evident during the lifting: if the drive stops during the lifting of the load this has to come to a speed equals to zero (static irreversibility) before the reversal of motion rotation and its drop for gravity.

On the contrary the load during its descent gets its motion obstructed by its dynamic efficiency.

Rd < 0.45 provides irreversibility
Rd = 0.45 ÷ 0.55 irreversibility is uncertain
Rd > 0.55 reversibility is possible

Irréversibilité dynamique

Condition nécessaire pour arrêter et donc soutenir la charge au moment de l'arrêt de l'action de commande. Cette condition est la plus difficile à obtenir puisqu'elle est influencée par le rendement dynamique, la vitesse de rotation et les rotations éventuelles produites par la charge et la direction du mouvement par rapport à la charge.

Cette dernière condition est particulièrement évidente lors des élévations: une charge en montée, lorsque l'action de commande cesse, doit s'arrêter et sa vitesse est alors égale à zéro (rendement statique) avant d'inverser le mouvement et tomber sous l'effet de la force de gravité.

Une charge en descente a, au contraire, tendance à poursuivre son mouvement, gênée dans sa chute par le rendement dynamique.

Rd < 0.45 produit irréversibilité
Rd = 0.45 ÷ 0.55 irréversibilité incertaine
Rd > 0.55 réversibilité possible

3.5 Juego angular

Juego angular standard

Medido bloqueando el eje de entrada, y girando el eje de salida en las dos direcciones aplicando el par estrictamente necesario para crear el contacto entre los dientes de los engranajes, como máximo igual al 2% del par nominal (T_{2M}).

3.5 Backlash

Backlash

Angular backlash measured after having blocked the input shaft by rotating output shaft in both directions and applying the torque which is strictly necessary to create a contact between the teeth of the gears. The applied torque should be at most 2% of the max. torque (T_{2M}).

3.5 Jeu d'angle

Jeu d'angle standard

Mesuré en bloquant l'arbre d'entrée et en tournant l'arbre dans les deux directions en appliquant le couple strictement nécessaire pour créer le contact avec les dents des engrenages, équivalent à 2% max. du couple nominal (T_{2M}).

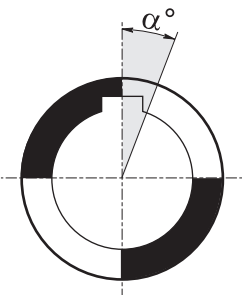

GK						
i_n	30	40	50	63	75	89
	max	max	max	max	max	max
5	16'	13.5'	10.5'	10'	/	/
7.5	16'	13.5'	10.5'	10'	10'	9.5'
10	16'	13.5'	10.5'	10'	10'	9'
15	16'	13.5'	10.5'	10'	10'	9'
20	14.5'	12'	9.5'	8.5'	8.5'	8.5'
25	14.5'	12'	9.5'	8.5'	8.5'	8.5'
30	14.5'	12'	8.5'	8.5'	8.5'	8.5'
40	14.5'	12'	9.5'	8.5'	8.5'	8'
50	14'	12'	9.5'	8.5'	8.5'	8'
65	14'	12'	9'	8'	8'	8'
80	13.5'	11.5'	9'	7.5'	7.5'	7.5'
100	13'	11'	9'	7.5'	7.5'	7.5'

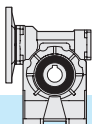

3.6 Carga radial

Carga radial Fr_2 Carga axial Fa_2
en el eje de salida [N]

Si la carga radial en el eje no se aplica a la mitad de la protuberancia del eje, el valor de carga admisible debe evaluarse utilizando la fórmula que se refiere a Fry2, en la cual los valores de a, b y Fr_2 se informan en las tablas relativas a cargas radiales

En los ejes con salida doble, cada extremidad puede soportar una carga radial igual a 3/5 del valor de la tabla, siempre y cuando las cargas aplicables sean de igual intensidad y reaccionen en el mismo sentido.

De lo contrario, póngase en contacto con el servicio técnico.

3.6 Radial load

Fr_2 radial loads and Fa_2 axial loads on the output shaft [N]

Should the radial load affect the shaft not at the half-way point of its projection but at a different point, the value of the admissible load has to be calculated using the Fry₂ formula: a, b and Fr₂ values are reported in the radial load tables.

With regard to double-projecting shafts, the load applicable at each end is 2/3 of the value given in the table, on condition that the applied loads feature same intensity and direction and that they act in the same direction.

Otherwise please contact the technical department.

3.6 Charges radiales

Charge radiale Fr_2 Charge axiale Fa_2
sur le puits de sortie [N]

Si la charge radiale sur l'arbre n'est pas appliquée sur la moitié de la saillie de l'arbre, la valeur de charge admissible doit être évaluée à l'aide de la formule faisant référence à Fry2, dans laquelle les valeurs de a, b et Fr_2 sont rapportées dans les tableaux relatifs à charges radiales.

Pour les arbres dépassant des deux cotés qui tournent dans le même sens et à la même vitesse, chaque extrémité devra supporter une charge radiale égale aux 3/5 des valeurs du tableau.

Sinon, contactez le service technique.

Las cargas radiales que se muestran en las tablas están destinadas a aplicarse en el centro de la extensión del eje y se refieren a las cajas de engranajes que funcionan con el factor de servicio 1.

The radial loads indicated in the chart are considered to be applied at the half-way point of the shaft projection, and refer to gear units operating with service factor 1.

Les charges radiales indiquées dans les tableaux sont destinées à être appliquées au milieu du prolongement d'arbre et font référence à des boîtes de vitesses fonctionnant avec le facteur de service 1.

		GK											
$n_1=1400$ rpm		30		40		50		63		75		89	
i_n	n_2 [rpm]	a = 66.5 b = 49		a = 83.5 b = 60.5		a = 102 b = 73.5		a = 122.5 b = 93.5		a = 134 b = 100		a = 163 b = 118	
		Fr_2	Fa_2	Fr_2	Fa_2	Fr_2	Fa_2	Fr_2	Fa_2	Fr_2	Fa_2	Fr_2	Fa_2
5	280	700	140	1400	280	1400	300	1800	360	/	/	/	/
7.5	187	750	150	1500	300	1650	330	2100	420	2500	500	2600	520
10	140	800	160	1600	320	1800	360	2300	460	2800	560	3000	600
15	93	850	170	1700	340	1950	390	2600	520	3000	600	3400	680
20	70	900	180	1800	360	2200	440	2800	560	3300	660	3800	760
25	56	950	190	1900	380	2400	480	3100	620	3700	740	4100	820
30	47	1000	200	2000	400	2600	520	3400	680	4000	800	4500	900
40	35	1050	210	2100	420	2850	570	3700	740	4400	880	4900	980
50	28	1100	220	2200	440	3100	620	4000	800	4850	970	5300	1060
60	23	1150	230	2400	480	3200	640	4200	840	5000	1000	5600	1120
63	22	1250	250	2500	500	3400	680	4450	890	5300	1060	5900	1180
80	17.5	1350	270	2700	540	3800	760	4900	980	5800	1160	6500	1300
100	14	1500	300	3000	600	4000	800	5400	1080	6500	1300	7000	1400

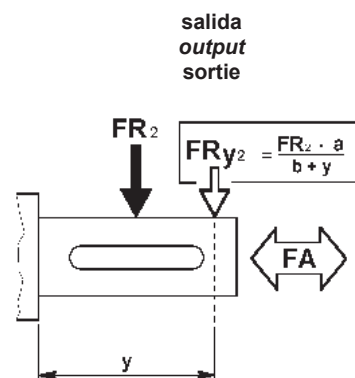

3.7 Sentido de rotación

3.7 Direction of rotation

3.7 Sens de rotation

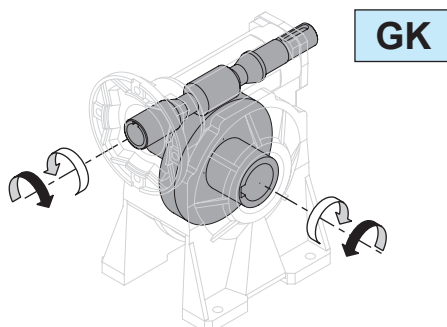

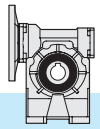

3.8 Lubricación

Los reductores de la serie GK se suministran con lubricante sintético para uso alimentario: FUCHS CASSIDA FLUID 320 OIL.

Se recomienda precisar ordenadamente las fases deseada de la posición de trabajo.

Para obtener más detalles, consulte el apartado 1.6 en la pág. 17.

3.8 Lubrication

The GK series worm gearboxes are supplied complete with synthetic lubricant for food use: FUCHS CASSIDA FLUID 320 OIL.

It is recommended to always specify the desired assembly position when placing the order.

For further details, please see page 17 paragraph 1.6

3.8 Lubrification

Les réducteurs à roue et vis sans fin de la série GK sont fournis dotés de lubrifiant synthétique à usage alimentaire: FUCHS CASSIDA FLUID 320 OIL.

Position de montage à spécifier lors de la commande.

Pour plus de détails, consulter le paragraphe 1.6 à la page 17.

Posición de montaje

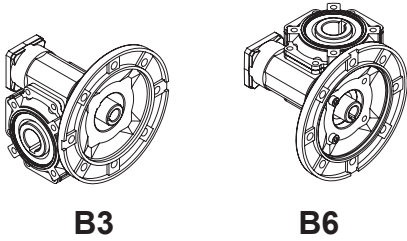

Mounting positions

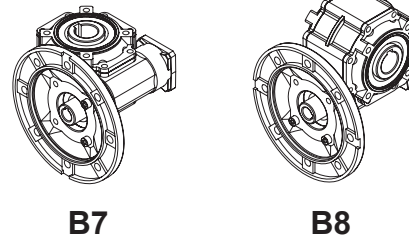

Positions de montage

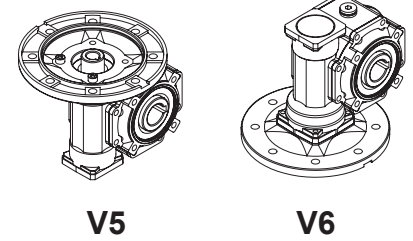

Hay un solo tapón de llenado del aceite.

There is only one filling plug only.

Il n'y a qu'un seul bouchon de remplissage de l'huile.

		Cant. de aceite / Oil quantity / Q.té d'huile [lt]			
		Posizione di montaggio / Mounting position / Positions de montage			
		B3	B6 - B7	B8	V5 - V6
GK	30	0.015	0.030	0.015	
	40	0.040	0.060	0.040	
	50	0.080	0.120	0.080	
	63	0.160	0.220	0.160	
	75	0.260	0.340	0.260	
	89	0.600	0.700	0.600	

3.9 Posición borne

3.9 Terminal board position

3.9 Position de la boîte à bornes

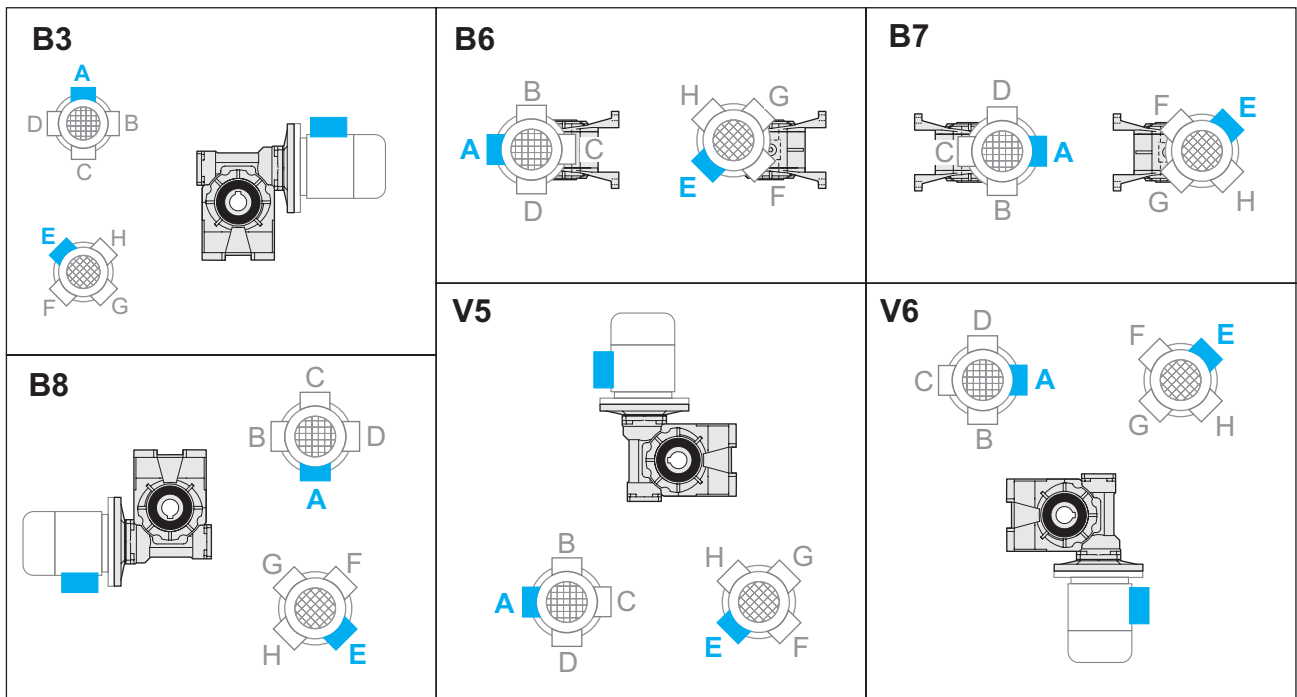

Especificar siempre ordenadamente la posición de montaje y su forma constructiva. Posición borne v. pág. 55 (PM=1; PM=2)

Mounting position always to be specified when ordering. Terminal board position see page 55 (PM=1; PM=2)

Lors de toute commande, il est recommandé de préciser la position de montage et la version désirées. Position de la boîte à bornes v. pag. 55 (PM=1; PM=2)

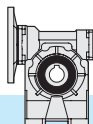

3.10 Datos técnicos

3.10 Technical data

3.10 Données techniques

GKC 30 Kg 1.2	$n_1 = 2800$				MOTORES / MOTORS / MOTEURS GHA CLASSIC				Input - IEC	
	i_n	n_2 [min ⁻¹]	Rd	P_{10}	T_2 [Nm]	P_1 [kW]	FS'	B5/B14		
								63	56	
	5	560	0.89	—	5.6	0.37	2.5			63
7.5	373	0.86	8		0.37	2.0				
10	280	0.84	11		0.37	1.5				
15	187	0.81	15		0.37	1.1				
20	140	0.76	13		0.25	1.2				
25	112	0.74	16		0.25	1.0				
30	93	0.71	13		0.18	1.0				
40	70	0.65	16		0.18	1.0				
50	56	0.62	14		0.13	1.1				
65	43	0.57	17		0.13	1.0				
80	35	0.54	13		0.09	1.0				
100	28	0.52	16		0.09	0.8				

GKC 30 Kg 1.2	$n_1 = 1400$				MOTORES / MOTORS / MOTEURS GHA CLASSIC				Input - IEC	
	i_n	n_2 [min ⁻¹]	Rd	P_{10}	T_2 [Nm]	P_1 [kW]	FS'	B5/B14		
								63	56	
	5	280	0.87	0.40	6.5	0.22	2.9			63
7.5	187	0.84	0.40	9	0.22	2.2				
10	140	0.82	0.40	12	0.22	1.8				
15	93	0.77	0.30	17	0.22	1.3				
20	70	0.72	0.20	18	0.18	1.1				
25	56	0.69	0.20	21	0.18	1.0				
30	47	0.66	0.20	18	0.13	1.1				
40	35	0.59	0.20	21	0.13	1.0				
50	28	0.55	0.20	17	0.09	1.1				
65	22	0.51	0.10	20	0.09	1.0				
80	18	0.48	0.10	16	0.06	1.0				
100	14	0.45	0.10	18	0.06	0.8				

GKC 30 Kg 1.2	$n_1 = 900$				MOTORES / MOTORS / MOTEURS GHA CLASSIC				Input - IEC	
	i_n	n_2 [min ⁻¹]	Rd	P_{10}	T_2 [Nm]	P_1 [kW]	FS'	B5/B14		
								63	56	
	5	180	0.85	—	5.9	0.13	3.9			63
7.5	120	0.82	9		0.13	2.9				
10	90	0.80	11		0.13	2.3				
15	60	0.75	15		0.13	1.6				
20	45	0.69	19		0.13	1.2				
25	36	0.66	23		0.13	1.1				
30	30	0.63	18		0.09	1.2				
40	23	0.55	21		0.09	1.1				
50	18	0.52	16		0.06	1.3				
65	14	0.48	20		0.06	1.1				
80	11	0.44	11		0.03	1.7				
100	9	0.42	13		0.03	1.1				

GKC 30 Kg 1.2	$n_1 = 500$				MOTORES / MOTORS / MOTEURS GHA CLASSIC				Input - IEC	
	i_n	n_2 [min ⁻¹]	Rd	P_{10}	T_2 [Nm]	P_1 [kW]	FS'	B5/B14		
								63	56	
	5	100	0.83	—	—	—	—			63
7.5	67	0.80	—		—	—				
10	50	0.77	—		—	—				
15	33	0.72	—		—	—				
20	25	0.66	—		—	—				
25	20	0.62	—		—	—				
30	17	0.59	—		—	—				
40	13	0.51	—		—	—				
50	10	0.48	—		—	—				
65	8	0.43	—		—	—				
80	6	0.40	—		—	—				
100	5	0.38	—		—	—				

* **ATENCIÓN:** el par máximo utilizable [T_{2M}] deberá calcularse con respecto al factor de servicio: $T_{2M} = T_2 \times FS'$

* **WARNING:** Maximum allowable torque [T_{2M}] must be calculated using the following service factor: $T_{2M} = T_2 \times FS'$

* **ATTENTION :** le couple maximum admissible [T_{2M}] se calcule en utilisant le facteur de service suivant : $T_{2M} = T_2 \times FS'$

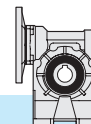



3.10 Datos técnicos

3.10 Technical data

3.10 Données techniques

GKC 40	$n_1 = 2800$				MOTORES / MOTORS / MOTEURS GHA CLASSIC							
	i_n	n_2 [min ⁻¹]	Rd	P_{t0}	T_2 [Nm]	P_1 [kW]	FS'	Input - IEC B5/B14				
								71	63	—		
 2.0	5	560	0.88	—	11.3	0.75	2.2	71	63	—		
	7.5	373	0.87		17	0.75	1.8					
	10	280	0.86		22	0.75	1.4					
	15	187	0.82		32	0.75	1.0					
	20	140	0.80		30	0.55	1.0					
	25	112	0.76		24	0.37	1.1					
	30	93	0.73		28	0.37	1.3					
	40	70	0.70		24	0.25	1.4					
	50	56	0.65		28	0.25	1.1					
	65	43	0.61		24	0.18	1.2					
80	35	0.58	21	0.13	1.3							
100	28	0.55	24	0.13	1.0							

GKC 40	$n_1 = 1400$				MOTORES / MOTORS / MOTEURS GHA CLASSIC							
	i_n	n_2 [min ⁻¹]	Rd	P_{t0}	T_2 [Nm]	P_1 [kW]	FS'	Input - IEC B5/B14				
								71	63	—		
 2.0	5	280	0.87	0.80	16.3	0.55	2.1	71	63	—		
	7.5	187	0.85	0.80	24	0.55	1.7					
	10	140	0.83	0.70	31	0.55	1.3					
	15	93	0.79	0.50	30	0.37	1.4					
	20	70	0.76	0.50	38	0.37	1.0					
	25	56	0.72	0.40	31	0.25	1.1					
	30	47	0.68	0.40	35	0.25	1.2					
	40	35	0.64	0.30	38	0.22	1.0					
	50	28	0.59	0.30	36	0.18	1.1					
	65	22	0.54	0.20	31	0.13	1.1					
80	18	0.52	0.20	31	0.11	1.1						
100	14	0.49	0.20	30	0.09	0.9						

GKC 40	$n_1 = 900$				MOTORES / MOTORS / MOTEURS GHA CLASSIC							
	i_n	n_2 [min ⁻¹]	Rd	P_{t0}	T_2 [Nm]	P_1 [kW]	FS'	Input - IEC B5/B14				
								71	63	—		
 2.0	5	180	0.85	—	16.7	0.37	2.5	71	63	—		
	7.5	120	0.83		25	0.37	2.0					
	10	90	0.81		32	0.37	1.5					
	15	60	0.76		45	0.37	1.1					
	20	45	0.74		39	0.25	1.2					
	25	36	0.69		33	0.18	1.3					
	30	30	0.65		37	0.18	1.3					
	40	23	0.61		33	0.13	1.3					
	50	18	0.55		38	0.13	1.1					
	65	14	0.51		32	0.09	1.2					
80	11	0.48	37	0.09	1.0							
100	9	0.45	29	0.06	1.0							

GKC 40	$n_1 = 500$				MOTORES / MOTORS / MOTEURS GHA CLASSIC							
	i_n	n_2 [min ⁻¹]	Rd	P_{t0}	T_2 [Nm]	P_1 [kW]	FS'	Input - IEC B5/B14				
								71	63	—		
 2.0	5	100	0.83	—	7.1	0.09	7.1	71	63	—		
	7.5	67	0.81		10	0.09	5.5					
	10	50	0.79		14	0.09	4.4					
	15	33	0.73		19	0.09	3.1					
	20	25	0.70		24	0.09	2.3					
	25	20	0.65		28	0.09	1.7					
	30	17	0.61		31	0.09	1.8					
	40	13	0.57		39	0.09	1.3					
	50	10	0.51		44	0.09	1.2					
	65	8	0.46		52	0.09	0.9					
80	6	0.44	61*	0.09	0.7*							
100	5	0.41	71*	0.09	0.4*							

* **ATENCION:** el par máximo utilizable [T_{2M}] deberá calcularse con respecto al factor de servicio: $T_{2M} = T_2 \times FS'$

* **WARNING:** Maximum allowable torque [T_{2M}] must be calculated using the following service factor: $T_{2M} = T_2 \times FS'$

* **ATTENTION :** le couple maximum admissible [T_{2M}] se calcule en utilisant le facteur de service suivant : $T_{2M} = T_2 \times FS'$

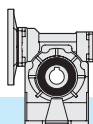

3.10 Datos técnicos

3.10 Technical data

3.10 Données techniques

GKC 50	$n_1 = 2800$				MOTORES / MOTORS / MOTEURS GHA CLASSIC							
	i_n	n_2 [min ⁻¹]	Rd	P_{t0}	T_2 [Nm]	P_1 [kW]	FS'	Input - IEC B5/B14				
								80	71	—		
Kg 3.4	5	560	0.89	—	22.8	1.5	1.9	80	71	—		
	7.5	373	0.88		34	1.5	1.5					
	10	280	0.86		44	1.5	1.2					
	15	187	0.84		47	1.1	1.2					
	20	140	0.81		42	0.75	1.4					
	25	112	0.78		50	0.75	1.0					
	30	93	0.75		42	0.55	1.3					
	40	70	0.72		54	0.55	1.0					
	50	56	0.68		43	0.37	1.3					
	65	43	0.64		53	0.37	1.0					
	80	35	0.61		41	0.25	1.2					
100	28	0.58	35	0.18	1.3							

GKC 50	$n_1 = 1400$				MOTORES / MOTORS / MOTEURS GHA CLASSIC							
	i_n	n_2 [min ⁻¹]	Rd	P_{t0}	T_2 [Nm]	P_1 [kW]	FS'	Input - IEC B5/B14				
								80	71	—		
Kg 3.4	5	280	0.87	1.2	26.7	0.9	2.3	80	71	—		
	7.5	187	0.86	1.2	40	0.9	1.8					
	10	140	0.84	1.0	52	0.9	1.4					
	15	93	0.80	0.80	74	0.9	1.0					
	20	70	0.78	0.70	58	0.55	1.3					
	25	56	0.74	0.60	47	0.37	1.4					
	30	47	0.71	0.60	53	0.37	1.2					
	40	35	0.67	0.50	68	0.37	1.0					
	50	28	0.62	0.40	53	0.25	1.3					
	65	22	0.58	0.40	64	0.25	1.0					
	80	18	0.54	0.40	53	0.18	1.1					
100	14	0.51	0.30	45	0.13	1.2						

GKC 50	$n_1 = 900$				MOTORES / MOTORS / MOTEURS GHA CLASSIC							
	i_n	n_2 [min ⁻¹]	Rd	P_{t0}	T_2 [Nm]	P_1 [kW]	FS'	Input - IEC B5/B14				
								80	71	—		
Kg 3.4	5	180	0.85	—	33.8	0.75	2.2	80	71	—		
	7.5	120	0.84		50	0.75	1.6					
	10	90	0.82		66	0.75	1.3					
	15	60	0.78		68	0.55	1.3					
	20	45	0.75		59	0.37	1.5					
	25	36	0.71		70	0.37	1.1					
	30	30	0.67		79	0.37	1.0					
	40	23	0.63		67	0.25	1.1					
	50	18	0.59		78	0.25	1.0					
	65	14	0.54		67	0.18	1.1					
	80	11	0.51		56	0.13	1.2					
100	9	0.47	45	0.09	1.3							

GKC 50	$n_1 = 500$				MOTORES / MOTORS / MOTEURS GHA CLASSIC							
	i_n	n_2 [min ⁻¹]	Rd	P_{t0}	T_2 [Nm]	P_1 [kW]	FS'	Input - IEC B5/B14				
								80	71	—		
Kg 3.4	5	100	0.84	—	14.3	0.18	6.4	80	71	—		
	7.5	67	0.82		21	0.18	4.7					
	10	50	0.80		28	0.18	3.8					
	15	33	0.75		39	0.18	2.7					
	20	25	0.72		50	0.18	2.1					
	25	20	0.68		58	0.18	1.5					
	30	17	0.63		65	0.18	1.5					
	40	13	0.59		81	0.18	1.2					
	50	10	0.54		93	0.18	1.0					
	65	8	0.50		56	0.09	1.5					
	80	6	0.46		63	0.09	1.2					
100	5	0.43	74	0.09	0.8							

* **ATENCION:** el par máximo utilizable [T_{2M}] deberá calcularse con respecto al factor de servicio: $T_{2M} = T_2 \times FS'$

* **WARNING:** Maximum allowable torque [T_{2M}] must be calculated using the following service factor: $T_{2M} = T_2 \times FS'$

* **ATTENTION :** le couple maximum admissible [T_{2M}] se calcule en utilisant le facteur de service suivant : $T_{2M} = T_2 \times FS'$

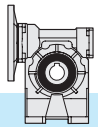

3.10 Datos técnicos

3.10 Technical data

3.10 Données techniques

GKC 63	$n_1 = 2800$				MOTORES / MOTORS / MOTEURS GHA CLASSIC					
	i_n	n_2 [min ⁻¹]	Rd	P_{t0}	T_2 [Nm]	P_1 [kW]	FS'	Input - IEC B5/B14		
								90	80	—
Kg 5.7	5	560	0.89	—	45.5	3	1.7	—	80	71
	7.5	373	0.88		68	3	1.3			
	10	280	0.87		89	3	1.1			
	15	187	0.84		95	2.2	1.0			
	20	140	0.83		85	1.5	1.3			
	25	112	0.81		76	1.1	1.2			
	30	93	0.77		87	1.1	1.3			
	40	70	0.74		111	1.1	1.1			
	50	56	0.70		90	0.75	1.1			
	65	43	0.67		81	0.55	1.2			
80	35	0.64	65	0.37	1.4					
100	28	0.60	75	0.37	1.1					

GKC 63	$n_1 = 1400$				MOTORES / MOTORS / MOTEURS GHA CLASSIC					
	i_n	n_2 [min ⁻¹]	Rd	P_{t0}	T_2 [Nm]	P_1 [kW]	FS'	Input - IEC B5/B14		
								90	80	—
Kg 5.7	5	280	0.88	1.8	54	1.8	2.0	—	80	71
	7.5	187	0.87	1.8	80	1.8	1.5			
	10	140	0.85	1.6	105	1.8	1.2			
	15	93	0.81	1.2	125	1.5	1.1			
	20	70	0.80	1.2	120	1.1	1.2			
	25	56	0.77	1.0	118	0.9	1.0			
	30	47	0.73	0.90	134	0.9	1.1			
	40	35	0.69	0.80	142	0.75	1.1			
	50	28	0.65	0.70	122	0.55	1.0			
	65	22	0.61	0.60	100	0.37	1.2			
80	18	0.58	0.60	79	0.25	1.4				
100	14	0.53	0.50	91	0.25	1.1				

GKC 63	$n_1 = 900$				MOTORES / MOTORS / MOTEURS GHA CLASSIC					
	i_n	n_2 [min ⁻¹]	Rd	P_{t0}	T_2 [Nm]	P_1 [kW]	FS'	Input - IEC B5/B14		
								90	80	—
Kg 5.7	5	180	0.87	—	69	1.5	1.9	—	80	71
	7.5	120	0.85		102	1.5	1.4			
	10	90	0.83		133	1.5	1.1			
	15	60	0.79		139	1.1	1.1			
	20	45	0.77		123	0.75	1.4			
	25	36	0.74		109	0.55	1.3			
	30	30	0.70		122	0.55	1.3			
	40	23	0.66		154	0.55	1.1			
	50	18	0.61		120	0.37	1.2			
	65	14	0.57		98	0.25	1.4			
80	11	0.54	115	0.25	1.1					
100	9	0.50	95	0.18	1.2					

GKC 63	$n_1 = 500$				MOTORES / MOTORS / MOTEURS GHA CLASSIC					
	i_n	n_2 [min ⁻¹]	Rd	P_{t0}	T_2 [Nm]	P_1 [kW]	FS'	Input - IEC B5/B14		
								90	80	—
Kg 5.7	5	100	0.85	—	20	0.25	8.3	—	80	71
	7.5	67	0.83		30	0.25	5.9			
	10	50	0.81		39	0.25	4.7			
	15	33	0.76		55	0.25	3.4			
	20	25	0.74		71	0.25	2.8			
	25	20	0.71		85	0.25	1.9			
	30	17	0.65		94	0.25	2.1			
	40	13	0.62		118	0.25	1.7			
	50	10	0.56		135	0.25	1.2			
	65	8	0.52		163	0.25	1.0			
80	6	0.50	137	0.18	1.1					
100	5	0.45	77	0.09	1.6					

* **ATENCION:** el par máximo utilizable [T_{2M}] deberá calcularse con respecto al factor de servicio: $T_{2M} = T_2 \times FS'$

* **WARNING:** Maximum allowable torque [T_{2M}] must be calculated using the following service factor: $T_{2M} = T_2 \times FS'$

* **ATTENTION :** le couple maximum admissible [T_{2M}] se calcule en utilisant le facteur de service suivant : $T_{2M} = T_2 \times FS'$

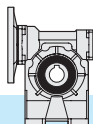

3.10 Datos técnicos

3.10 Technical data

3.10 Données techniques

GKC 75 Kg 9.5	n₁ = 2800				MOTORES / MOTORS / MOTEURS GHA CLASSIC							
	i _n	n ₂ [min ⁻¹]	Rd	P _{t0}	T ₂ [Nm]	P ₁ [kW]	FS'	Input - IEC B5/B14				
								112	100	90	80	
	7.5	373	0.89	—	125	5.5	1.0	112	100	90	—	—
	10	280	0.88		120	4	1.2					
	15	187	0.85		131	3	1.2					
	20	140	0.84		171	3	1.0					
	25	112	0.82		154	2.2	1.0					
	30	93	0.78		120	1.5	1.4					
	40	70	0.75		154	1.5	1.2					
	50	56	0.73		136	1.1	1.2					
	65	43	0.69		114	0.75	1.4					
	80	35	0.66		135	0.75	1.1					
	100	28	0.62	159	0.75	0.8	—	—	80	71		

GKC 75 Kg 9.5	n₁ = 1400				MOTORES / MOTORS / MOTEURS GHA CLASSIC							
	i _n	n ₂ [min ⁻¹]	Rd	P _{t0}	T ₂ [Nm]	P ₁ [kW]	FS'	Input - IEC B5/B14				
								112	100	90	80	
	7.5	187	0.87	2.5	178	4	1.0	112	100	90	—	—
	10	140	0.86	2.3	176	3	1.1					
	15	93	0.83	1.9	187	2.2	1.1					
	20	70	0.81	1.7	199	1.8	1.1					
	25	56	0.78	1.5	200	1.5	1.0					
	30	47	0.74	1.2	167	1.1	1.3					
	40	35	0.71	1.1	213	1.1	1.1					
	50	28	0.67	1.0	206	0.9	1.0					
	65	22	0.63	0.90	154	0.55	1.3					
	80	18	0.60	0.80	180	0.55	1.0					
	100	14	0.56	0.70	210	0.55	0.8	—	—	80	71	

GKC 75 Kg 9.5	n₁ = 900				MOTORES / MOTORS / MOTEURS GHA CLASSIC							
	i _n	n ₂ [min ⁻¹]	Rd	P _{t0}	T ₂ [Nm]	P ₁ [kW]	FS'	Input - IEC B5/B14				
								112	100	90	80	
	7.5	120	0.86	—	205	3	1.0	112	100	90	—	—
	10	90	0.84		197	2.2	1.2					
	15	60	0.81		231	1.8	1.0					
	20	45	0.78		250	1.5	1.1					
	25	36	0.76		221	1.1	1.1					
	30	30	0.71		249	1.1	1.0					
	40	23	0.67		214	0.75	1.3					
	50	18	0.64		186	0.55	1.3					
	65	14	0.59		151	0.37	1.5					
	80	11	0.56		177	0.37	1.2					
	100	9	0.52	203	0.37	0.9	—	—	80	71		

GKC 75 Kg 9.5	n₁ = 500				MOTORES / MOTORS / MOTEURS GHA CLASSIC							
	i _n	n ₂ [min ⁻¹]	Rd	P _{t0}	T ₂ [Nm]	P ₁ [kW]	FS'	Input - IEC B5/B14				
								112	100	90	80	
	7.5	67	0.84	—	90	0.75	2.9	112	100	90	—	—
	10	50	0.82		118	0.75	2.4					
	15	33	0.78		167	0.75	1.7					
	20	25	0.75		216	0.75	1.5					
	25	20	0.72		260	0.75	1.1					
	30	17	0.67		288	0.75	1.1					
	40	13	0.63		265	0.55	1.2					
	50	10	0.59		210	0.37	1.3					
	65	8	0.55		251	0.37	1.0					
	80	6	0.52		197	0.25	1.2					
	100	5	0.47	161	0.18	1.3	—	—	80	71		

* **ATENCION:** el par máximo utilizable [T_{2M}] deberá calcularse con respecto al factor de servicio: T_{2M} = T₂ x FS'

* **WARNING:** Maximum allowable torque [T_{2M}] must be calculated using the following service factor : T_{2M} = T₂ x FS'

* **ATTENTION :** le couple maximum admissible [T_{2M}] se calcule en utilisant le facteur de service suivant : T_{2M} = T₂ x FS'

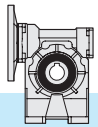

3.10 Datos técnicos

3.10 Technical data

3.10 Données techniques

GKC 89	$n_1 = 2800$				MOTORES / MOTORS / MOTEURS GHA CLASSIC					
	i_n	n_2 [min ⁻¹]	Rd	P_{t0}	T_2 [Nm]	P_1 [kW]	FS'	Input - IEC B5/B14		
Kg 16.4	7.5	373	0.89	—	171	7.5	1.2	112 100	90	—
	10	280	0.88		165	5.5	1.3			
	15	187	0.86		241	5.5	1.0			
	20	140	0.84		230	4	1.2			
	25	112	0.83		212	3	1.2			
	30	93	0.79		243	3	1.1			
	40	70	0.77		230	2.2	1.3	—	80	
	50	56	0.74		278	2.2	1.0			
	65	43	0.71		235	1.5	1.1			
	80	35	0.68		205	1.1	1.2			
	100	28	0.64		163	0.75	1.3			

GKC 89	$n_1 = 1400$				MOTORES / MOTORS / MOTEURS GHA CLASSIC					
	i_n	n_2 [min ⁻¹]	Rd	P_{t0}	T_2 [Nm]	P_1 [kW]	FS'	Input - IEC B5/B14		
Kg 11.5	7.5	187	0.88	3.0	247	5.5	1.2	112 100	90	—
	10	140	0.86	2.5	236	4	1.3			
	15	93	0.84	2.2	256	3	1.2			
	20	70	0.82	2.0	334	3	1.1			
	25	56	0.80	1.8	299	2.2	1.1			
	30	47	0.76	1.5	340	2.2	1.0			
	40	35	0.72	1.3	355	1.8	1.1	—	80	
	50	28	0.69	1.1	353	1.5	1.0			
	65	22	0.65	1.0	317	1.1	1.0			
	80	18	0.63	1.0	309	0.9	1.0			
	100	14	0.58	0.80	217	0.55	1.2			

GKC 89	$n_1 = 900$				MOTORES / MOTORS / MOTEURS GHA CLASSIC					
	i_n	n_2 [min ⁻¹]	Rd	P_{t0}	T_2 [Nm]	P_1 [kW]	FS'	Input - IEC B5/B14		
Kg 11.5	7.5	120	0.86	—	206	3	1.7	112 100	90	—
	10	90	0.85		270	3	1.3			
	15	60	0.82		286	2.2	1.3			
	20	45	0.79		371	2.2	1.1			
	25	36	0.77		369	1.8	1.0			
	30	30	0.73		416	1.8	1.0			
	40	23	0.69		440	1.5	1.0	—	80	
	50	18	0.66		384	1.1	1.0			
	65	14	0.62		319	0.75	1.1			
	80	11	0.59		274	0.55	1.2			
	100	9	0.54		313	0.55	1.0			

GKC 89	$n_1 = 500$				MOTORES / MOTORS / MOTEURS GHA CLASSIC					
	i_n	n_2 [min ⁻¹]	Rd	P_{t0}	T_2 [Nm]	P_1 [kW]	FS'	Input - IEC B5/B14		
Kg 11.5	7.5	67	0.84	—	91	0.75	4.7	112 100	90	—
	10	50	0.83		118	0.75	3.7			
	15	33	0.79		169	0.75	2.7			
	20	25	0.76		219	0.75	2.3			
	25	20	0.74		265	0.75	1.7			
	30	17	0.68		294	0.75	1.6			
	40	13	0.65		371	0.75	1.4	—	80	
	50	10	0.61		439	0.75	1.1			
	65	8	0.57		388	0.55	1.1			
	80	6	0.54		305	0.37	1.3			
	100	5	0.49		344	0.37	1.0			

* **ATENCIÓN:** el par máximo utilizable [T_{2M}] deberá calcularse con respecto al factor de servicio: $T_{2M} = T_2 \times FS'$

* **WARNING:** Maximum allowable torque [T_{2M}] must be calculated using the following service factor: $T_{2M} = T_2 \times FS'$

* **ATTENTION :** le couple maximum admissible [T_{2M}] se calcule en utilisant le facteur de service suivant : $T_{2M} = T_2 \times FS'$

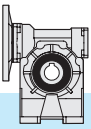

3.11 **Momento de inercia** [Kg·cm²]
(referido al eje rápido de entrada)

3.11 **Moments of inertia** [Kg·cm²]
(referred to input shaft)

3.11 **Moments d'inertie** [Kg·cm²]
(se rapportant à l'arbre d'entrée)

	i_n	GKC	
		B5 - B14	
		IEC 56	IEC 63
GK30	5	0.130	0.127
	7.5	0.112	0.109
	10	0.103	0.100
	15	0.097	0.094
	20	0.095	0.092
	25	0.094	0.091
	30	0.093	0.090
	40	0.093	0.090
	50	0.092	0.089
	65	0.079	-
	80	0.079	-
	100	0.078	-

	i_n	GKC		
		B5 - B14		
		IEC 56	IEC 63	IEC 71
GK40	5	-	0.391	0.463
	7.5	-	0.321	0.356
	10	-	0.272	0.347
	15	-	0.266	0.340
	20	-	0.263	0.338
	25	-	0.262	0.337
	30	-	0.262	0.337
	40	-	0.261	0.336
	50	0.182	0.261	-
	65	0.182	0.261	-
	80	0.182	0.261	-
	100	0.182	0.261	-

	i_n	GKC		
		B5 - B14		
		IEC 63	IEC 71	IEC 80
GK50	5	-	0.922	1.046
	7.5	-	0.684	0.935
	10	-	0.602	0.853
	15	-	0.543	0.794
	20	-	0.523	0.774
	25	-	0.513	0.764
	30	-	0.508	0.759
	40	0.315	0.503	0.755
	50	0.313	0.501	-
	65	0.311	0.499	-
	80	0.310	0.498	-
	100	0.309	0.498	-

	i_n	GKC		
		B5 - B14		
		IEC 71	IEC 80	IEC 63
GK63	5	-	2.431	2.671
	7.5	-	1.949	2.269
	10	-	1.744	2.063
	15	-	1.597	1.916
	20	-	1.545	1.864
	25	-	1.514	1.833
	30	-	1.508	1.828
	40	0.966	1.495	-
	50	0.959	1.488	-
	65	0.955	1.484	-
	80	0.953	1.482	-
	100	0.952	1.481	-

	i_n	GKC			
		B5 - B14			
		IEC 71	IEC 80	IEC 90	IEC 100-112
GK75	7.5	-	-	3.712	4.462
	10	-	-	3.234	3.984
	15	-	-	2.893	3.643
	20	-	-	2.774	3.523
	25	-	-	2.709	3.458
	30	1.615	1.575	2.689	3.438
	40	-	1.573	2.659	-
	50	-	1.570	2.642	-
	65	1.609	1.569	2.633	-
	80	1.605	1.565	2.629	-
	100	1.602	1.562	2.626	-

	i_n	GKC		
		B5 - B14		
		IEC 80	IEC 90	IEC 100-112
GK89	7.5	-	6.898	7.671
	10	-	5.875	6.648
	15	-	5.144	5.917
	20	-	3.398	5.661
	25	-	3.256	5.520
	30	-	3.215	5.479
	40	-	3.151	-
	50	-	3.115	-
	65	2.024	3.096	-
	80	2.014	3.087	-
	100	2.008	3.080	-

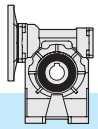

3.12 Tamaño

3.12 Dimensions

3.12 Dimensions

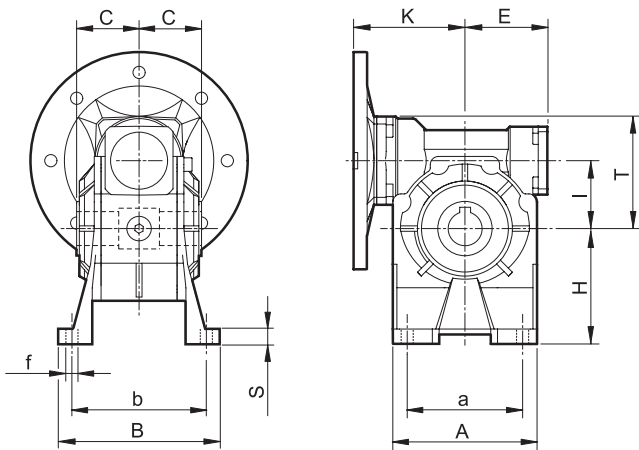

GKC..A

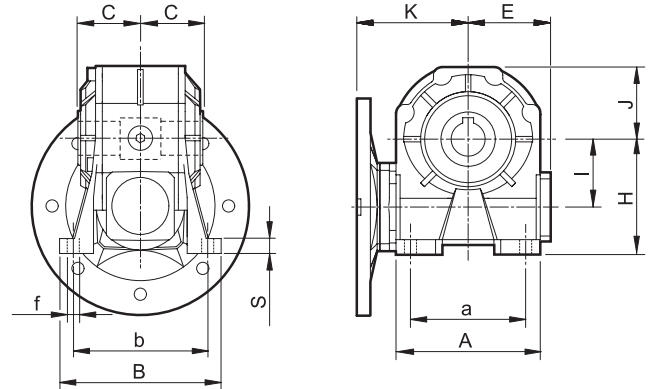

GKC..B

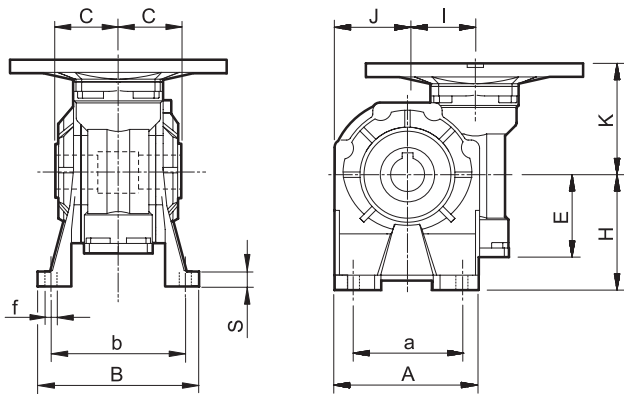

GKC..V

	30	40	50	63	75	89
b2	5	6	8	8	8	10
C	31.5	39	46	56	60	70
D2 H8	14	18	25	25	28	35
E	41	51	60	71	85	103
G h8	55	60	70	80	95	110
I	31.5	40	50	63	75	90
J	37.5	43.5	53.5	64	78	100
K	57	75	82	97	114 - 112 ⁽¹⁾	122
M	M6x8	M6x10	M8x10	M8x14	M8x14	M10x18
Pp	29	36.5	43.5	53	57	67
R	65	75	85	95	115	130
T	52.5	68.5	82.5	100.5	116.5	131.5
t2	16.3	20.8	28.3	28.3	31.3	38.3
X	1.5	1.5	1.5	2	2	2

(1): Solo para PAM 71B14 / Only for PAM 71B14 / juste pour PAM 71B14

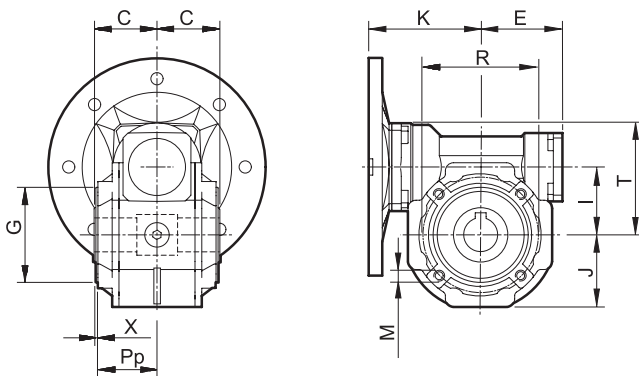

Brida pendular / Side cover for shaft mounting / Bride pendulaire

	Piedi Feet Fuß	30	40	50	63	75	89
A	1	67	86.5	106	127.5	155.5	190
	2	67	86.5	106			190
a	1	40-52	70	63-85	95	120	140
	2	40-52	52	63-85			140
B	1	78	98	119	136	140	168
	2	78	98	119			168
b	1	66	84	99	111	115	140
	2	66	81	99			146
f	1	6.5	7	9	11	11	13
	2	6.5	8.5	9			11
H	1	52	71	85	100	115	135
	2	55	72	82			142
S	1	5	9	11	12	12	14
	2	8	10	8			14

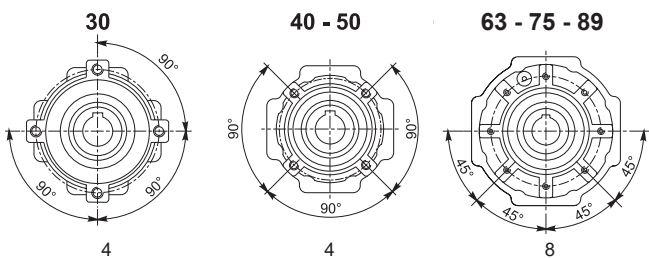

Agujeros / Holes / Troux

GKC..P

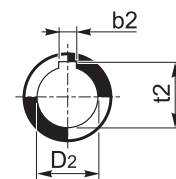

Eje hueco de salida
Hollow output shaft
Arbre de sortie creux

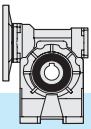

3.12 Tamaño

3.12 Dimensions

3.12 Dimensions

Brida de salida / Output flange / Bride de sortie

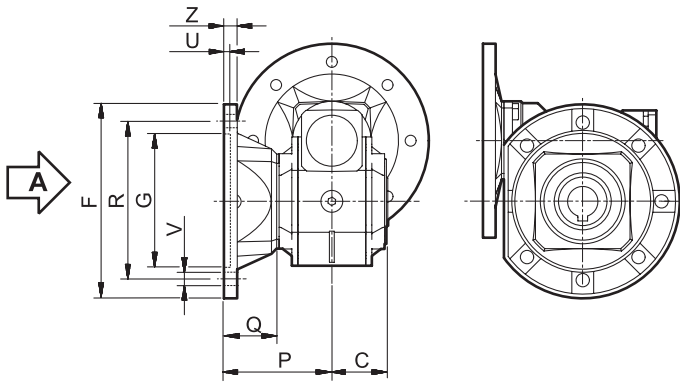

GKC..F

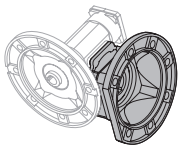

F...D
Standard

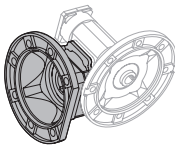

F...S

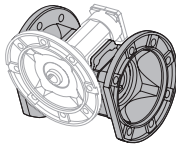

F...2

Vista de A / View from A / Vue depuis A

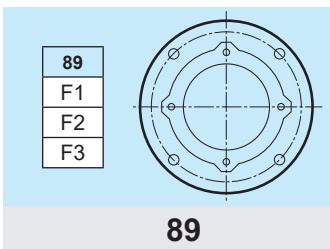
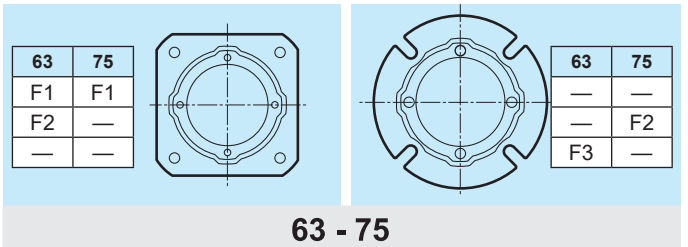
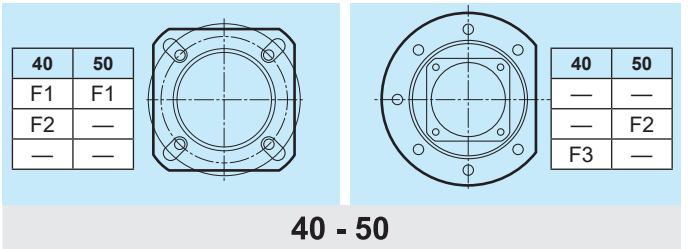
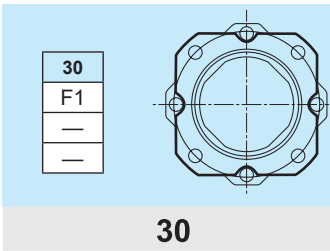

GKC	C	F		G H8	P	Q	R	U	V			Z
											Ø	
30	31.5		66	50	54.5	23	68	4	n° 4		6.5	6
40	39		85	60	67	28	75-90	4	n° 4		9	8
			85	60	97	58	75-90	4	n° 4		9	8
		140		95	80	41	115	5		n° 7	9	10
50	46		94	70	90	44	85-100	5	n° 4		11	10
		160		110	89	43	130	5		n° 7	11	11
63	56		142	115	82	26	150	5	n° 4		11	11
			142	115	112	56	150	5	n° 4		11	11
		160		110	80.5	24.5	130	5	n° 4		11	12
75	60		160	130	111	51	165	5	n° 4		13	12
		160		110	90	30	130	6	n° 4		11	13
89	70		200	152	111	41	175	5	n° 4		13	12
			200	152	151	81	175	5	n° 4		13	13
			200	130	110	40	165	6	n° 4		11	11

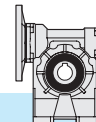

3.12 Tamaño

3.12 Dimensions

3.12 Dimensions

Brida entrada / *Input flange* / Briede d'entrée

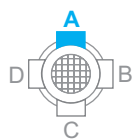

PM = 1

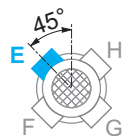

PM = 2

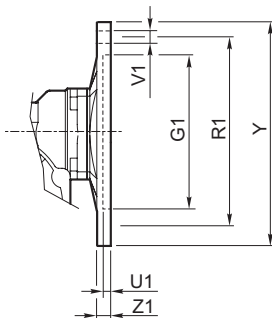

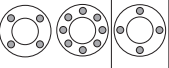
GKC	IEC	G ₁	PM		R ₁	U ₁	V ₁			Y	Z ₁	Diámetro orificio PAM / Holes diameter IEC / Diamètres trous PAM												
			1	2			Ø		5			7.5	10	15	20	25	30	40	50	65	80	100		
30	56 B5	80	•	•	100	4	7	8		120	8	9	9	9	9	9	9	9	9	9	9	9	9	
	56 B14	50	•	•	65	3.5	6	8		80	8	9	9	9	9	9	9	9	9	9	9	9	9	
	63 B5	95	•	•	115	4	9	8		140	8	11	11	11	11	11	11	11	11	11	11	/	/	
	63 B14	60	•	•	75	4	6	8		90	8	11	11	11	11	11	11	11	11	11	11	/	/	
40	56 B5	80	•	•	100	4	7	8		120	9	/	/	/	/	/	/	/	/	/	9	9	9	9
	56 B14	50	•	•	65	3.5	6		4	80	8	/	/	/	/	/	/	/	/	/	9	9	9	9
	63 B5	95	•	•	115	4	9	8		140	9	11	11	11	11	11	11	11	11	11	11	11	11	11
	63 B14	60	•	•	75	3.5	6		4	90	8	11	11	11	11	11	11	11	11	11	11	11	11	11
	71 B5	110	•	•	130	4.5	9	8		160	10	14	14	14	14	14	14	14	14	14	/	/	/	/
	71 B14	70	•	•	85	3.5	7	8		105	8	14	14	14	14	14	14	14	14	14	/	/	/	/
50	63 B5	95	•	•	115	4	9	8		140	9	/	/	/	/	/	/	/	/	11	11	11	11	11
	63 B14	60	•	•	75	3.5	6		4	90	8	/	/	/	/	/	/	/	/	11	11	11	11	11
	71 B5	110	•	•	130	4.5	9	8		160	10	14	14	14	14	14	14	14	14	14	14	14	14	14
	71 B14	70	•	•	85	3.5	7	(n° 8)*	4	105	8	14	14	14	14	14	14	14	14	14	14	14	14	14
	80 B5	130	•	•	165	4.5	11	8		200	10	19	19	19	19	19	19	19	19	19	/	/	/	/
	80 B14	80	•	•	100	4	7	8		120	10	19	19	19	19	19	19	19	19	19	/	/	/	/
63	71 B5	110	•	•	130	4.5	9	8		160	10	/	/	/	/	/	/	/	/	14	14	14	14	14
	71 B14	70	•	•	85	3.5	7		4	105	10	/	/	/	/	/	/	/	/	14	14	14	14	14
	80 B5	130	•	•	165	4.5	11	8		200	10	19	19	19	19	19	19	19	19	19	19	19	19	19
	80 B14	80	•	•	100	4	7		4	120	10	19	19	19	19	19	19	19	19	19	19	19	19	19
	90 B5	130	•	•	165	4.5	11	8		200	10	24	24	24	24	24	24	24	24	24	/	/	/	/
	90 B14	95	•	•	115	4	8.5	8		140	10	24	24	24	24	24	24	24	24	24	/	/	/	/
75	71 B5	110	•	•	130	4.5	9	8		160	10	/	/	/	/	/	/	/	14	/	/	14	14	14
	71 B14	70	•	•	85	4	7		4	105	11	/	/	/	/	/	/	14	/	/	14	14	14	14
	80 B5	130	•	•	165	4.5	11	8		200	10	/	/	/	/	/	/	19	19	19	19	19	19	19
	80 B14	80	•	•	100	4	7		4	120	11	/	/	/	/	/	/	19	19	19	19	19	19	19
	90 B5	130	•	•	165	4.5	11	8		200	10	/	24	24	24	24	24	24	24	24	24	24	24	24
	90 B14	95	•	•	115	4	9		4	140	11	/	24	24	24	24	24	24	24	24	24	24	24	24
	100/112 B5	180	•	•	215	5	14	8		250	13	/	28	28	28	28	28	28	28	/	/	/	/	/
	100/112 B14	110	•	•	130	4.5	9	8		160	11	/	28	28	28	28	28	28	28	/	/	/	/	/
89	80 B5	130	•	•	165	4.5	11	8		200	10	/	/	/	/	/	/	/	/	/	19	19	19	19
	80 B14	80	•	•	100	4	7		4	120	11	/	/	/	/	/	/	/	/	/	/	19	19	19
	90 B5	130	•	•	165	4.5	11	8		200	10	/	24	24	24	24	24	24	24	24	24	24	24	24
	90 B14	95	•	•	115	4	9		4	140	11	/	24	24	24	24	24	24	24	24	24	24	24	24
	100/112 B5	180	•	•	215	5	14	8		250	13	/	28	28	28	28	28	28	28	/	/	/	/	/
100/112 B14	110	•	•	130	4.5	9	8		160	11	/	28	28	28	28	28	28	28	/	/	/	/	/	

* A petición, solo con cuerpo especial / *Upon request, only with special body* / Uniquement corps spécial sur demande

N.B.: El montaje STD de P_M=2 solo cuando no es posible el montaje STD di P_M=1.

N.B.: Es posible también realizar todas las composiciones híbridas obtenibles de las bridas existentes.

N.B.: *STD mounting of P_M=2 only if STD mounting of P_M=1 is not possible.*

N.B.: *it is possible to create hybrid combinations with the existing flanges.*

N.B.: Montage STD P_M=2 seulement lorsque le montage STD P_M=1 n'est pas possible.

N.B.: Il est possible de réaliser des compositions hybrides à partir des bridas existantes.

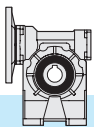

3.13 Entrada suplementaria
(tornillos con doble salida)

3.13 Additional input
(double extended shaft)

3.13 Entrée supplémentaire
(double vis)

S.e.A.

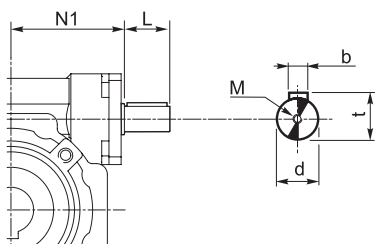

GKC	d j6	L	M	N1	b	t
30	9	15	M4x10	42.5	3	10.2
40	11	20	M4x12	52.5	4	12.5
50	14	25	M5x13	62.5	5	16
63	19	30	M8x20	72.5	6	21.5
75	24	40	M8x20	89	8	27
89	24	40	M8x20	108	8	27

3.14 Accesorios
(Brazo de reacción)

3.14 Accessories
(Torque arm)

3.14 Accessoires
(Bras de réaction)

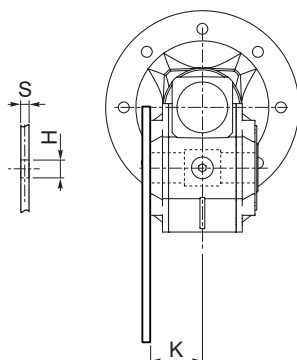
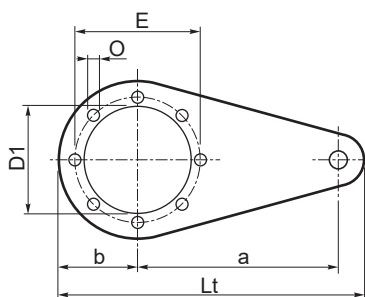

GK	a	b	D ₁	E	H	K	L _t	O	S
30	85	37	55	65	8	29	138	6.5 n°4	5
40	100	47	60	75	10	36.5	167	7 n°4	5
50	100	57.5	70	85	10	43.5	179	9 n°4	5
63	150	55	80	95	10	53	227	9 n°8	6
75	200	67	95	115	20	57	299	9 n°8	6
89	200	80	110	130	20	67	312	11 n°8	8

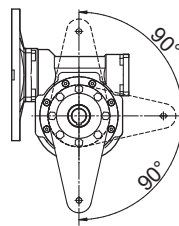

30 - 40 - 50

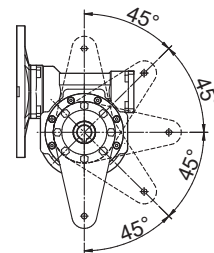

63 - 75 - 89

3.15 Lista de recambios

3.15 Spare parts list

3.15 Liste des pièces détachées

Cuando se ordene un recambio, especificar siempre el número particular de cada pieza referenciado en el despiece (ver gráfico de despiece) fecha (1), n° de código (2) y n° variable (3).
(Ver placa de características).

When ordering please specify the spare part number (see exploded view) as well as the date (1), the article number (2) and the variant number (3) (see plate).

Lors de la commande de pièces détachées, toujours rappeler le n° de la pièce (voir plan éclaté), la date (1), le n° de code (2) et le n° de la variante (3).
(Voir plaquette signalétique).

CODIGO: Lista de componentes

CODE: Base list

CODE: Liste du matériel

TIPO: descripción

TYPE: description

TYPE: description

RAP: relación de reducción

RATIO: reduction ratio

RAP: rapport de réduction

VARIANTE:

código alfanumérico

MODEL:

alphanumeric code

VARIANTE:

code alpha numérique

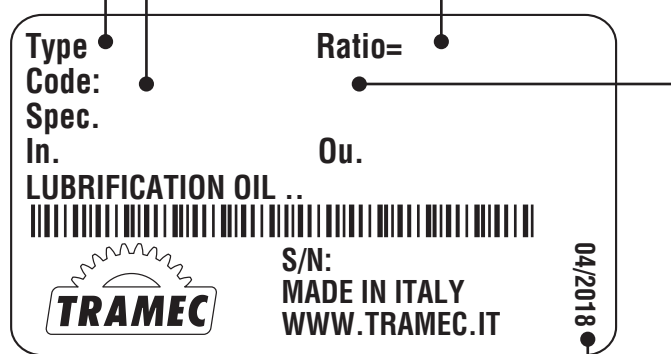

FECHA: mes/año

DATE: month/year

DATE: mois/année



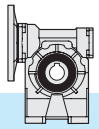

GK

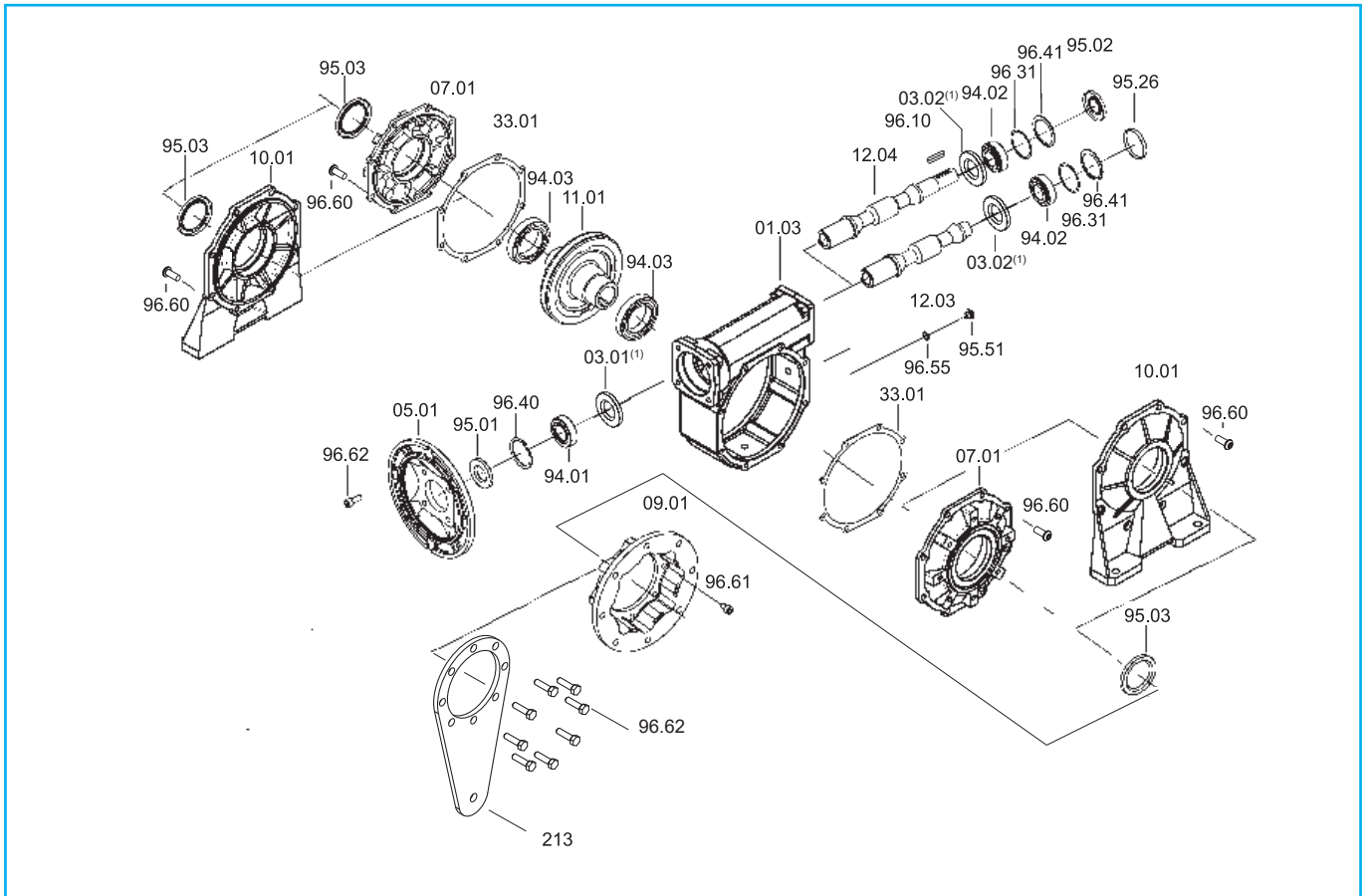

GKC	IEC	Cojinetes / Bearings / Roulements			Retenes / Oilseals / Bagues d'étanchéité			Casquete / Closed oil seal / Capot
		94.01	94.02	94.03	95.01	95.02	95.03	95.26
30	56	61804 (20x32x7)	6000 10x26x8	6005 25x47x12	20/32/7	10/26/7	25/40/7	ø 26x7
	63	61804 (20x32x7)			20/32/7			
40	56	6303 (17x47x14)	6201 12x32x10	6006 30x55x13	17/47/7	12/32/7	30/47/7	ø 32x7
	63	6204 (20x47x14)			30x55x17			
	71	6005 (25x47x12)			25/47/7			
50	63	6204 (20x47x14)	6203 17x40x12	6008 40x68x15	20/47/7	17/40/7	40/62/8	ø 40x7
	71	6005 (25x47x12)			25/47/7			
	80	6006 (30x55x13)			30/55/7			
63	71	6305 (25x62x17)	6204 C3 20x47x14	6008 40x68x15	25/62/7	20/47/7	40/62/8	ø 47x7
	80	6206 (30x62x16)			30/62/7			
	90	6007 (35x62x14)			35/62/7			
75	71	6206 (30x62x16)	6205 C3 25x52x15	6010 50x80x16	30/62/7	25/52/7	50/72/8	ø 52x7
	80	6206 (30x62x16)			30/62/7			
	90	6007 (35x62x14)			35/62/7			
	100/112	6008 (40x68x15)			40/68/10			
89	80	6206 (30x62x16)	6205 C3 25x52x15	6010 50x80x16	30/62/7	25/52/7	50/72/8	ø 52x7
	90	6007 (35x62x14)			35/62/7			
	100/112	6008 (40x68x15)			40/68/10			

(1): Solo para GK63, 75, 89 / Only for GK63, 75, 89 / Uniquement pour GK63, 75, 89.

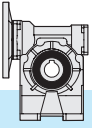

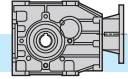

4.0 REDUCTOR DE EJES ORTOGONALES GT

BEVEL HELICAL GEARBOX GT

REDUCTEUR A ARBRES ORTHOGONAUX GT

4.1	Características	<i>Characteristics</i>	Caractéristiques	60
4.2	Nomenclatura	<i>Designation</i>	Désignation	61
4.3	Rendimiento	<i>Efficiency</i>	Rendement	62
4.4	Juego angular	<i>Backlash</i>	Jeu d'angle	62
4.5	Sentido de rotación de los ejes	<i>Direction of shaft rotation</i>	Sentido de rotación de los ejes	62
4.6	Cargas radiales	<i>Radial and axial loads</i>	Charges radiales	63
4.7	Lubricación	<i>Lubrication</i>	Lubrification	64
4.8	Posición del tablero de Borne	<i>Terminal board position</i>	Position de la boîte à bornes	65
4.9	Velocidad de entrada	<i>Input speed</i>	Vitesse d'entrée	65
4.10	Potencia térmica	<i>Thermal power</i>	Puissance thermique	66
4.11	Datos técnicos	<i>Technical data</i>	Données techniques	67
4.12	Momento de inercia	<i>Moments of inertia</i>	Moments d'inertie	68
4.13	Dimensiones	<i>Dimensions</i>	Dimensions	70
4.14	Accesorios	<i>Accessories</i>	Accessoires	73
4.15	Lista de recambios	<i>Spare parts list</i>	Liste des pièces détachées	71

GHA - CLASSIC

La serie CLASSIC es la serie estándar dentro de la gama de reductores GHA.

Las especiales características NANOTECNOLÓGICAS del revestimiento de la carcasa y su diseño externo permiten que los reductores de esta serie sean especialmente aptos para las aplicaciones en ambientes de la industria ALIMENTARIA y FARMACÉUTICA.

A pesar de que los reductores de la serie GHA CLASSIC están certificados como dispositivos adecuados para utilizarse en máquinas alimentarias y, por lo tanto, para aplicaciones en plantas de producción y manipulación de alimentos, no están certificados para utilizarse en contacto con alimentos.

GHA - CLASSIC

The CLASSIC series is the standard series within the range of GHA reducers.

The special NANOTECHNOLOGICAL properties of the case coating and its external construction, make the gearboxes of this series particularly suitable for applications in FOOD and PHARMACEUTICAL environments.

Although the GHA CLASSIC series reducers are certified as suitable devices for use on food processing machines and therefore for applications that operate in food production and handling plants, they are not certified for use in contact with food.

GHA - CLASSIC

La série CLASSIC constitue la série standard au sein de la gamme de réducteurs GHA.

Grâce aux caractéristiques spéciales NANOTECHNOLOGIQUES du revêtement de la carcasse et à leur design externe, les réducteurs de cette série conviennent tout particulièrement aux applications dans les environnements ALIMENTAIRE, PHARMACEUTIQUE.

Bien que les réducteurs de la série GHA CLASSIC soient certifiés en tant que dispositifs adaptés à l'utilisation sur des machines alimentaires et donc pour des applications qui opèrent dans des usines de production et de manipulation des aliments, ils ne sont pas certifiés pour l'utilisation au contact des aliments.

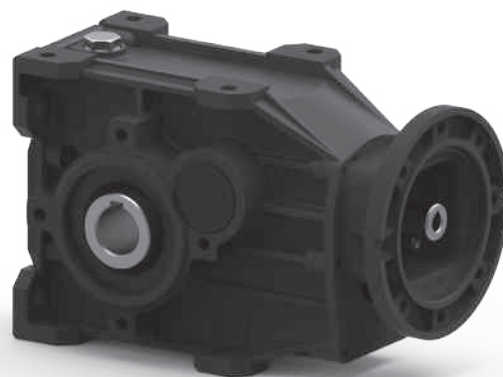

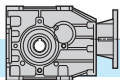

4.1 Características

- Los reductores con ejes ortogonales de la serie GT se fabrican en 3 tamaños de 2 y de 3 reducciones.
- Las carcasas y las bridas de aleación de aluminio son arenadas y tratadas con la tecnología G.H.A.
- Se prevé un tipo de entrada: con preparación para la conexión del motor (campana y manguito)
- El cuerpo del reductor de aleación de aluminio, GAISI9Cu1 UNI7369/3, tiene suficientes nervaduras internas y externas para garantizar la rigidez y está trabajado en todos los planos para facilitar la colocación.
- Los engranajes son de acero aleado de cementación y son sometidos a un tratamiento de cementación y temple. En particular, la primera reducción está formada por dos engranajes cónicos hipoides con un perfil cuidadosamente rodado, de acero 16NiCr4 o 18NiCrMo5 cementados y templados. Los engranajes cilíndricos con dientes helicoidales son de acero 16NiCr4, 18NiCrMo5 o 20MnCr5 UNI EN 10084 cementados y templados, rectificadas de acuerdo con la clase de calidad 6 de la norma DIN 3962.
- El eje lento hueco, que de serie es de acero inoxidable AISI 316, y la posibilidad de montar una brida de salida en uno o en ambos lados, aumentan la versatilidad de estos reductores, lo que facilita su instalación.
- Equipados con pernos de acero inoxidable, juntas de material certificado por la FDA y lubricantes para la industria alimentaria (categoría de certificación NSF H1).
- Para aplicaciones en el sector marítimo, no se utilizan lubricantes NSF H1 ni juntas de material certificado por la FDA.

4.1 Characteristics

- *The GT series orthogonal axis reducers are manufactured in 3 sizes with 2 and 3 reductions.*
- *The casings and flanges made of aluminium alloy are sandblasted and treated with G.H.A technology.*
- *One input type available and suitable for the motor mounting (bell and sleeve).*
- *The gear unit casing is in aluminum alloy GAISI9Cu1 UNI7369/3, internally and externally ribbed to guarantee rigidity and it is machined on all surfaces for easy positioning.*
- *The gears are built in casehardened compound steel and have undergone case-hardening and quench-hardening treatments. In particular, the first stage consists of two GLEASON spiral bevel gears with precise ground profile, in 16NiCr4 or 18NiCrMo5 case hardened and quench-hardened steel. The helical spur gears are built in 16NiCr4, 18NiCrMo5 or 20MnCr5 UNI EN 10084, quench – hardened and case-hardened steel, ground according and within Class 6 quality DIN 3962.*
- *The Stainless Steel AISI 316 hollow shaft together with the possibility to mount an output flange on one or both sides, enhance the versatility of these gearboxes, making it easy to install.*
- *Equipped with stainless steel nuts and bolts, seals made of FDA-certified material and lubricants for the food industry (NSF H1 certification category).*
- *For applications in the marine sector, NSF H1 lubricants and FDA-certified seals are not used.*

4.1 Caractéristiques

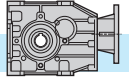

- Les réducteurs à axes orthogonaux de la série GT sont construits en 3 tailles à 2 et à 3 réductions.
- La carcasse et les brides en alliage d'aluminium sont sablées et traitées avec la technologie G.H.A.
- Un type d'entrée est prévu : avec agencement pour la fixation du moteur (cloche et manchon)
- Le corps du réducteur en alliage d'aluminium, GAISI9Cu1 UNI7369/3, abondamment strié à l'intérieur et à l'extérieur pour assurer la rigidité, est usiné sur tous les plans pour permettre un positionnement aisé.
- Les engrenages sont fabriqués en acier allié de cémentation et soumis à un traitement de cémentation et trempé. La première réduction est notamment constituée de deux engrenages coniques hypoïdes dont le profil est soigneusement rodé, en acier 16NiCr4 ou 18NiCrMo5, cimentés et trempés. Les engrenages cylindriques, à dents hélicoïdales, sont fabriqués en acier EN 10084, cimentés et trempés, et rectifiés dans la classe de qualité 6 de la norme DIN 3962.
- L'arbre lent creux en acier INOX AISI 316 de série, qui offre la possibilité de monter une brida de sortie sur un ou les deux flancs latéraux, améliorent la polyvalence de ces réducteurs en facilitant leur installation.
- Pourvus de boulons en INOX, de joints d'étanchéité réalisés dans un matériau certifié FDA et lubrifiants pour l'industrie alimentaire (catégorie de certification NSF H1).
- Pour les applications dans le secteur marin, les lubrifiants NSF H1 et joints d'étanchéité en matériau certifié FDA ne sont pas utilisés.



4.2 Nomenclatura

4.2 Designation

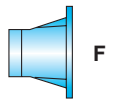
4.2 Désignation

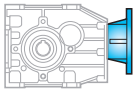
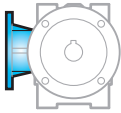
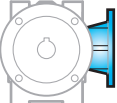
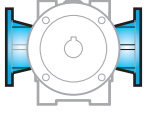
Reductor Gearbox Réducteur	Tipo de entrada Input type Type d'entrée	Tamaño Size Taille	Rotación Gearing Trains de réduction	Relación de reducción Ratio Rapport de réduction	Predisposición Motor coupling Prédisposition	Ejecución Execution Exécution	Posición de montaje Mounting position Position de montage	Eje hueco de salida Hollow output shaft Arbre de sortie creux	Brida de salida Output flange Bride de sortie	Campo de aplicación Field of application Domaine d'application
GT	F	63	B	10	P.A.M.	O	B3	25	FLS	A
Reductores con ejes ortogonales Bevel helical gearbox Réducteurs à arbres orthogonaux		56 63 75	B 	$i_n = 8 \div 315$	56 ÷ 100		B3 B6 B7 B8 VA VB	Ver la página con las dimensiones. See page dimensions Voir la page avec les dimensions	 FLS  FLD  FL2	A Alimentario y farmacéutico Food and Pharmaceutical Alimentaire et Pharmaceutique M* Marítimo Marine

*: a petición

*: on request

*: sur demande

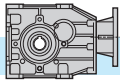

4.3 Rendimiento

El valor de rendimiento de los reductores puede ser estimado con suficiente aproximación en base al número de reducciones, ignorando las variaciones no significativas atribuibles a los distintos tamaños y relaciones.

4.3 Efficiency

The efficiency value of the gear units can be estimated sufficiently well on the basis of the number of reduction stages, ignoring non-significant variations which can be attributed to the various sizes and ratios.

4.3 Rendement

La valeur du rendement des réducteurs peut être calculée avec précision si on considère les trains de réduction et les variations non-significatives que l'on peut attribuer aux différentes tailles et rapports.

η	GTF..B	GTF..C
	0.95	0.93

4.4 Gioco angolare

Medido bloqueando el eje de entrada, y girando el eje de salida en las dos direcciones aplicando el par estrictamente necesario para crear el contacto entre los dientes de los engranajes, como máximo igual al 2% del par nominal (T_{2M}).

4.4 Backlash

Angular backlash measured after having blocked the input shaft by rotating output shaft in both directions and applying the torque which is strictly necessary to create a contact between the teeth of the gears. The applied torque should be at most 2% of the max. torque (T_{2M}).

4.4 Winkelspiel

Mesuré en bloquant l'arbre d'entrée et en tournant l'arbre dans les deux directions en appliquant le couple strictement nécessaire pour créer le contact avec les dents des engrenages, équivalent à 2% max. du couple nominal (T_{2M}).

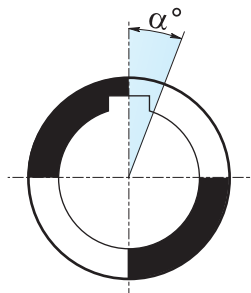

GT	
Juego angular máximo Maximum Backlash Jeu angulaire maximum	
2 etapas/stages/étapes	20'
3 etapas/stages/étapes	20'

4.5 Sentido de rotación

4.5 Direction of rotation

4.5 Sens de rotation

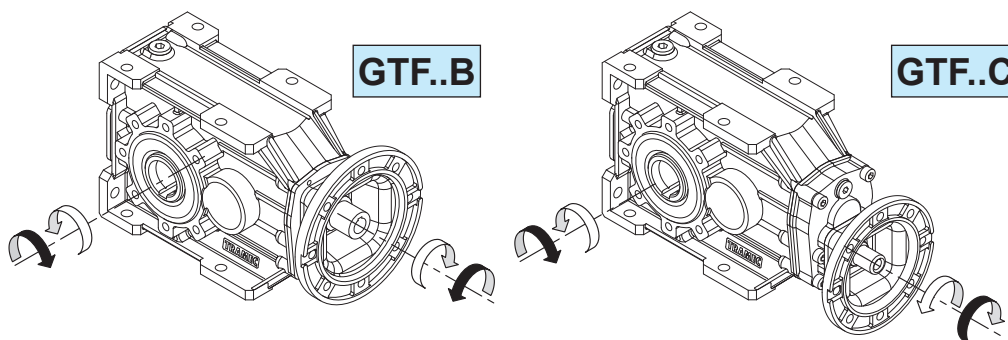

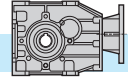

4.6 Carga radial

Carga radial Fr_2 Carga axial Fa_2
en el eje de salida [N]

Si la carga radial en el eje no se aplica a la mitad de la protuberancia del eje, el valor de carga admisible debe evaluarse utilizando la fórmula que se refiere a Fry2, en la cual los valores de a, b y Fr_2 se informan en las tablas relativas a cargas radiales

En los ejes con salida doble, cada extremidad puede soportar una carga radial igual a 3/5 del valor de la tabla, siempre y cuando las cargas aplicables sean de igual intensidad y reaccionen en el mismo sentido.

De lo contrario, póngase en contacto con el servicio técnico.

4.6 Radial load

Fr_2 radial loads and Fa_2 axial loads on the output shaft [N]

Should the radial load affect the shaft not at the half-way point of its projection but at a different point, the value of the admissible load has to be calculated using the Fry₂ formula: a, b and Fr₂ values are reported in the radial load tables.

With regard to double-projecting shafts, the load applicable at each end is 2/3 of the value given in the table, on condition that the applied loads feature same intensity and direction and that they act in the same direction.

Otherwise please contact the technical department.

4.6 Charges radiales

Charge radiale Fr_2 Charge axiale Fa_2
sur le puits de sortie [N]

Si la charge radiale sur l'arbre n'est pas appliquée sur la moitié de la saillie de l'arbre, la valeur de charge admissible doit être évaluée à l'aide de la formule faisant référence à Fry2, dans laquelle les valeurs de a, b et Fr_2 sont rapportées dans les tableaux relatifs à charges radiales.

Pour les arbres dépassant des deux côtés qui tournent dans le même sens et à la même vitesse, chaque extrémité devra supporter une charge radiale égale aux 3/5 des valeurs du tableau.

Sinon, contactez le service technique.

Las cargas radiales que se muestran en las tablas están destinadas a aplicarse en el centro de la extensión del eje y se refieren a las cajas de engranajes que funcionan con el factor de servicio 1.

The radial loads indicated in the chart are considered to be applied at the half-way point of the shaft projection, and refer to gear units operating with service factor 1.

Les charges radiales indiquées dans les tableaux sont destinées à être appliquées au milieu du prolongement d'arbre et font référence à des boîtes de vitesses fonctionnant avec le facteur de service 1.

		GT 56B		GT 63B		GT 75B				GT 56C		GT 63C		GT 75C	
EJE DE SALIDA / OUTPUT SHAFT / ARBRE DE SORTIE ($n_1 = 1400 \text{ min}^{-1}$)															
in	a = 106	b = 81	a = 121	b = 93.5	a = 106	b = 81	in	a = 106	b = 81	a = 121	b = 93.5	a = 121	b = 93.5		
	Fr_2	Fa_2	Fr_2	Fa_2	Fr_2	Fa_2		Fr_2	Fa_2	Fr_2	Fa_2	Fr_2	Fa_2		
8	1300	260	1500	300	2500	500	40	2300	460	2500	500	—	—		
10	1300	260	1500	300	2500	500	50	2300	460	2500	500	3500	700		
12.5	1300	260	1500	300	2500	500	63	2300	460	2500	500	3500	700		
16	1800	360	2000	400	2500	500	80	2800	560	3000	600	3500	700		
20	1800	360	2000	400	3000	600	100	2800	560	3000	600	4000	800		
25	1800	360	2000	400	3000	600	125	2800	560	3000	600	4000	800		
31.5	1800	360	2000	400	3000	600	160	2800	560	3000	600	4000	800		
40	2300	460	2500	500	3500	700	200	3000	600	3500	700	4500	900		
50	2300	460	2500	500	3500	700	250	3000	600	3500	700	4500	900		
63	—	—	2500	500	—	—	315	—	—	3500	700	—	—		

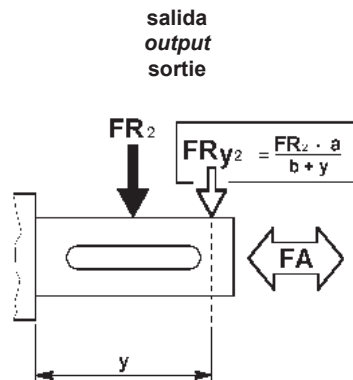

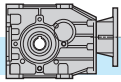

4.7 Lubricación

Los reductores con ejes ortogonales GTF56, GTF63 y GTF75 son lubricados de por vida con aceite alimentario FUCHS CASSIDA FLUID 320. La grasa lubricante aplicada en los cojinetes es adecuada para uso alimentario, es la grasa FUCHS CASSIDA GREASE HTS2.

Se recomienda especificar siempre la posición de montaje deseada al realizar el pedido.

Para obtener más detalles, consulte el apartado 1.6 en la pág. 17.

En las posiciones de montaje con cojinetes colocados por encima del nivel del aceite lubricante, se debe aplicar grasa especial en dichos cojinetes para mejorar su lubricación. Es posible equipar dichos cojinetes con un anillo metálico (nylos) con la función de contener la grasa y, de consecuencia, prolongar el efecto a lo largo del tiempo. Esta solución se suministra bajo pedido específico.

Posiciones de montaje y cantidad de lubricante (litros)

Las cantidades de aceite indicadas en las distintas tablas, son indicativas y se refieren a las posiciones de trabajo indicadas, considerando las condiciones de funcionamiento a temperatura ambiente y velocidad de entrada de 1400 min⁻¹. Para condiciones de trabajo diversas de las arriba indicadas, contactar a nuestro servicio técnico.

4.7 Lubrication

Bevel helical gearboxes type GTF56, GTF63 and GTF75 are lubricated for life with FUCHS CASSIDA FLUID 320 oil. The grease FUCHS CASSIDA GREASE HTS2 applied on the bearings is compatible with food use.

It is recommended to always specify the desired assembly position when placing the order.

For further details, please see page 17 paragraph 1.6

Depending on the mounting position the bearings may be lodged above the lubricant level. In this case, it is necessary to apply special grease on the bearings to improve their lubrication. A metallic ring (nylos-ring) can be fitted on the bearings, it keeps the grease in place thus prolonging the action. It is supplied on specific request.

Mounting positions and lubricant quantity (liters)

The oil quantities stated in the tables are approximate values and refer to the indicated working positions, considering operating conditions at ambient temperature and an input speed of 1400 min⁻¹. Should the operating conditions be different, please contact the technical service.

4.7 Lubrification

Les réducteurs à axes orthogonaux GTF56, GTF63 et GTF75 sont lubrifiés à vie avec de l'huile alimentaire FUCHS CASSIDA FLUID 320. La graisse lubrifiante appliquée sur les roulements, la FUCHS CASSIDA GREASE HTS2, est compatible avec un usage alimentaire.

Toujours préciser la position de montage désirée au moment de la commande.

Pour plus de détails, consulter le paragraphe 1.6 à la page 17.

Dans les positions de montage où il y a des roulements installés au-dessus du niveau de l'huile lubrifiante, l'application d'une graisse spéciale est prévue sur ces roulements pour en améliorer la lubrification. Il est possible de doter ces roulements d'un anneau métallique (nylos) servant à contenir la graisse et par conséquent, à prolonger son effet dans le temps. Cette solution est fournie sur demande spécifique.

Position de montage et quantité d'huile (litres)

Les quantités d'huile indiquées dans le tableau sont indicatives et concernent les positions de montage indiquées et calculées pour fonctionnement à température ambiante et avec une vitesse à l'entrée de 1400 t/min⁻¹. Pour des conditions de travail différentes contacter le service technique.

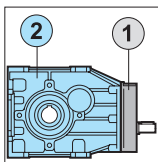
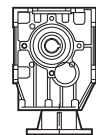
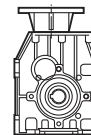
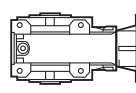
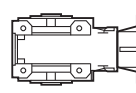
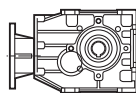
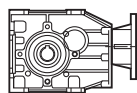

	GT	B3	B8	B6	B7	VA	VB
②	56B		0.30			0.40	0.30
①	56C			0.05			
②	56C		0.30			0.40	0.30
②	63B		0.35			0.45	0.35
①	63C			0.05			
②	63C		0.35			0.45	0.35
②	75B			0.45			
①	75C			0.08			
②	75C			0.45			

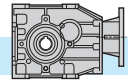

4.8 Posición borne

4.8 Terminal board position

4.8 Position de la boîte à bornes

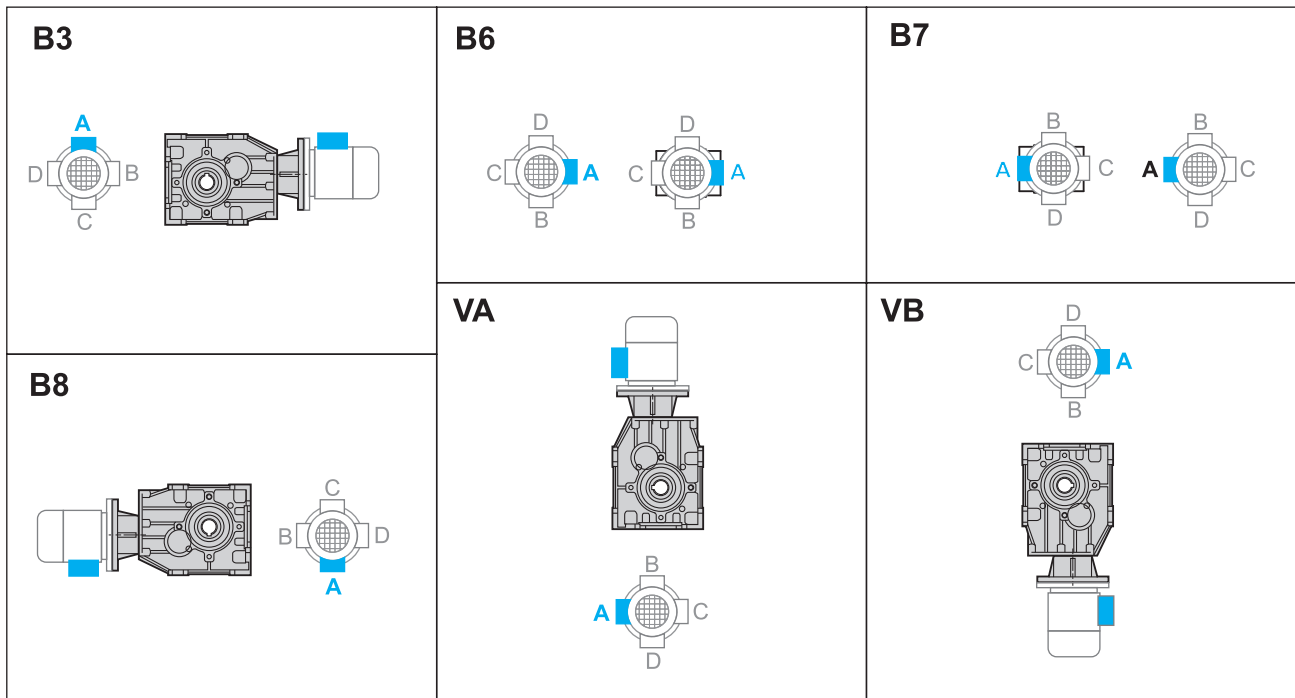

Especificar siempre ordenadamente la posición de montaje y su forma constructiva.

Mounting position always to be specified when ordering.

Lors de toute commande, il est recommandé de préciser la position de montage et la version désirées.

2.6 Velocidad de entrada

Todas las prestaciones de los reductores son calculadas en base a una velocidad de entrada de 1400 min⁻¹. Todos los reductores admiten velocidades hasta 3000 min⁻¹, sin embargo aconsejamos, donde la aplicación lo permita, utilizar frecuencias menores a 1400 min⁻¹.

En la tabla siguiente, se encuentran los coeficientes correctivos de la potencia en entrada P a las varias velocidades referidas a FS = 1

4.9 Input speed

All calculations of gear unit performance are based on an input speed of 1400 min⁻¹. All gear units permit speed up to 3000 min⁻¹, nevertheless it is advisable to keep below 1400 min⁻¹, depending on application.

The table below reports input power P corrective coefficients at the various speeds, with Fs = 1.

2.6 Vitesse d'entrée

Toutes les performances des réducteurs sont calculées sur la base d'une vitesse d'entrée de 1400 min⁻¹. Tous les réducteurs admettent des vitesses jusqu'à 3000 min⁻¹ même s'il est conseillé d'utiliser des valeurs inférieures à 1400 min⁻¹, pour les applications qui le permettent.

Dans le tableau ci-dessous figurent les coefficients de correction de la puissance en entrée P aux différentes vitesses, se référant à FS = 1.

Tab. 1

n ₁ (rpm)	3000	2800	2200	1800	1400	900	700	500
P _c (kW)	P x 1.9	P x 1.8	P x 1.48	P x 1.24	P x 1	P x 0.7	P x 0.56	P x 0.42

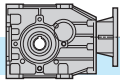

4.10 Potencia térmica

Los valores de las potencias térmicas P_{10} (kW) se detallan en la siguiente tabla en función del tamaño, de la relación y de la de la velocidad de rotación de entrada del reductor.

Los valores se calculan considerando el uso de aceite sintético ISO 320.

Véase apartado 1.5 para la elección de los factores de corrección.

4.10 Thermal power

The following table shows the values of thermal power P_{10} (kW) for each gearbox size on the basis of ratio and input speed. The values have been calculated considering the utilization of synthetic oil ISO 320. See chapter 1.5 for the corrective coefficients.

4.10 Puissance thermique

La valeur de la puissance thermique P_{10} (kW), relative à la taille de chaque réducteur orthogonal est indiquée dans le tableau suivant sur la base de la vitesse de rotation à l'entrée du réducteur.

Les valeurs sont calculées en considérant l'utilisation d'huile synthétique ISO 320.

Voir paragraphe 1.5 pour le choix des facteurs correctifs.

Potencia térmica / Thermal power / Puissance thermique P_{10} [kW]						
	GTF56B		GTF63B		GTF75B	
i_n	1400	2800	1400	2800	1400	2800
8						
10						
12.5						
16						
20	4	3.4	5.5	4.7	5.6	4.8
25						
31.5						
40						
50						
63	-	-	-	-	-	-
80						

Potencia térmica / Thermal power / Puissance thermique P_{10} [kW]						
	GTF56C		GTF63C		GTF75C	
i_n	1400	2800	1400	2800	1400	2800
40					-	-
50						
63						
80						
100	3.3	2.8	4.2	3.6	4.3	3.7
125						
160						
200						
250						
315						
400	-	-	-	-	-	-
500						
630						

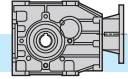

4.11 Datos técnicos

4.11 Technical data

4.11 Données techniques

GT	n ₁ = 1400			MOTORES / MOTORS / MOTEURS GHA CLASSIC			
	in	ir	n ₂ rpm	T ₂ Nm	P1 kW	FS'	IEC
56B	8	8.06	174	94	1.8	1.2	56
	10	10.17	138	120	1.8	1.0	63
	12.5	12.31	114	120	1.5	1.1	(B5)
	16	15.00	93	107	1.1	1.3	71
	20	20.33	69	140	1.1	1.0	80
	25	24.62	57	140	0.9	1.0	90
	31.5	30.00	47	107	0.55	1.3	(B5)
	40	39.38	36	140	0.55	1.0	(B14)
	50	48.00	29	115	0.37	1.2	TF
56C	40	40.28	35	140	0.55	1.0	56
	50	50.83	28	119	0.37	1.2	63
	63	61.54	23	140	0.37	1.0	(B5)
	80	75.00	19	119	0.25	1.2	71
	100	101.67	14	145	0.22	1.0	80
	125	123.08	11	141	0.18	1.0	90
	160	150.00	9	124	0.13	1.2	(B5)
	200	196.92	7	136	0.11	1.1	(B14)
	250	240.00	6	135	0.09	1.0	TF
63B	8	7.94	176	93	1.8	1.7	56
	10	10.18	138	119	1.8	1.4	63
	12.5	12.50	112	146	1.8	1.3	(B5)
	16	15.88	88	185	1.8	1.0	71
	20	20.36	69	200	1.5	1.0	80
	25	25.00	56	180	1.1	1.1	90
	31.5	31.00	45	181	0.9	1.1	(B5)
	40	40.00	35	194	0.75	1.0	(B14)
	50	49.60	28	177	0.55	1.0	TF
	63	60.80	23	146	0.37	1.0	TF
63C	40	39.71	35	194	0.75	1.0	56
	50	50.89	28	178	0.55	1.2	63
	63	62.50	22	210	0.55	1.0	(B5)
	80	79.41	18	186	0.37	1.1	71
	100	101.79	14	161	0.25	1.3	80
	125	125.00	11	198	0.25	1.0	90
	160	155.00	9	210	0.22	1.0	(B5)
	200	200.00	7	165	0.13	1.3	(B14)
	250	248.00	6	200	0.13	1.0	TF
	315	304.00	5	180	0.09	1.0	TF
75B	8	7.87	178	204	4.0	1.2	71
	10	9.82	143	254	4.0	1.1	80
	12.5	12.67	110	330	4.0	1.0	90
	16	15.43	91	299	3.0	1.1	100
	20	19.38	72	277	2.2	1.3	112
	25	25.00	56	356	2.2	1.0	(B5)
	31.5	30.45	46	355	1.8	1.1	(B14)
	40	40.00	35	285	1.1	1.3	TF
	50	48.73	29	344	1.1	1.1	TF
75C	50	49.08	29	330	1.1	1.0	63
	63	63.33	22	303	0.75	1.1	(B5)
	80	77.15	18	271	0.55	1.3	71
	100	96.88	14	350	0.55	1.0	80
	125	125.00	11	299	0.37	1.2	90
	160	152.27	9	247	0.25	1.4	(B5)
	200	200.00	7	317	0.25	1.2	(B14)
	250	243.64	6	370	0.25	1.0	TF

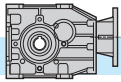

4.12 **Momento de inercia** [Kg·cm²]
(del eje rápido de entrada)

4.12 **Moments of inertia** [Kg·cm²]
(referred to input shaft)

4.12 **Moments d'inertie** [Kg·cm²]
(se rapportant à l'arbre d'entrée)

GTF..B

56B	i_n	GTF				
		IEC B5				
		56	63	71	80	90
8			0.32	0.40	0.60	0.77
10	0.29	0.29	0.37	0.56	0.74	
12.5	0.27	0.27	0.35	0.54	0.72	
16	0.25	0.26	0.33	0.53	0.71	
20	0.15	0.15	0.22	0.42	0.60	
25	0.14	0.15	0.22	0.42	0.59	
31.5	0.14	0.14	0.21	0.41	0.59	
40	0.11	0.12	0.19	0.39	0.56	
50	0.11	0.11	0.19	0.39	0.56	

63B	i_n	GTF				
		IEC B5				
		56	63	71	80	90
8	0.47	0.47	0.55	0.74	0.92	
10	0.41	0.42	0.49	0.69	0.87	
12.5	0.38	0.38	0.45	0.65	0.83	
16	0.23	0.24	0.31	0.51	0.68	
20	0.22	0.22	0.29	0.49	0.67	
25	0.21	0.21	0.29	0.48	0.66	
31.5	0.20	0.21	0.28	0.48	0.65	
40	0.15	0.15	0.22	0.42	0.60	
50	0.14	0.15	0.22	0.42	0.60	
63	0.14	0.15	0.22	0.42	0.59	

75B	i_n	GTF			
		IEC B5			
		71	80	90	100-112
8	1.70	2.10	2.01	3.05	
10	1.55	1.96	1.87	2.91	
12.5	1.39	1.80	1.71	2.75	
16	1.34	1.74	1.65	2.69	
20	0.71	1.11	1.02	2.06	
25	0.67	1.07	0.98	2.02	
31.5	0.65	1.06	0.97	2.01	
40	0.51	0.92	0.82	1.86	
50	0.50	0.91	0.82	1.86	

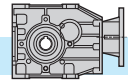



4.12 **Momento de inercia** [Kg·cm²]
(del eje rápido de entrada)

4.12 **Moments of inertia** [Kg·cm²]
(referred to input shaft)

4.12 **Moments d'inertie** [Kg·cm²]
(se rapportant à l'arbre d'entrée)

GTF..C

56C	i_n	 GTF				
		IEC B5				
		56	63	71	80	90
	40	0.136	0.139	0.212	0.410	0.588
	50	0.134	0.138	0.211	0.409	0.587
	63	0.134	0.137	0.210	0.408	0.586
	80	0.133	0.137	0.210	0.408	0.585
	100	0.129	0.132	0.205	0.403	0.581
	125	0.129	0.132	0.205	0.403	0.581
	160	0.128	0.132	0.205	0.403	0.581
	200	0.127	0.131	0.204	0.402	0.580
	250	0.127	0.131	0.204	0.402	0.580

63C	i_n	 GTF				
		IEC B5				
		56	63	71	80	90
	40	0.142	0.145	0.218	0.416	0.594
	50	0.139	0.143	0.216	0.414	0.592
	63	0.138	0.142	0.215	0.413	0.590
	80	0.132	0.136	0.209	0.407	0.585
	100	0.132	0.135	0.208	0.406	0.584
	125	0.131	0.135	0.208	0.406	0.584
	160	0.131	0.135	0.208	0.406	0.583
	200	0.129	0.132	0.205	0.403	0.581
	250	0.129	0.132	0.205	0.403	0.581
	315	0.129	0.132	0.205	0.403	0.581

75C	i_n	 GTF			
		IEC B5			
		63	71	80	90
	50	0.179	0.252	0.450	0.628
	63	0.173	0.246	0.444	0.622
	80	0.171	0.244	0.442	0.619
	100	0.145	0.219	0.417	0.594
	125	0.144	0.217	0.415	0.593
	160	0.143	0.216	0.414	0.592
	200	0.138	0.211	0.409	0.586
	250	0.137	0.210	0.408	0.586

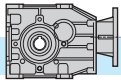

4.13 Dimensiones

4.13 Dimensions

4.13 Dimensions

GTF56B...

GTF56C...

2 Reducciones/Stages/Reduções

3 Reducciones/Stages/Reduções

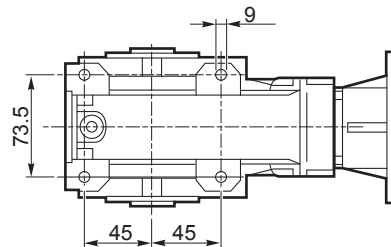
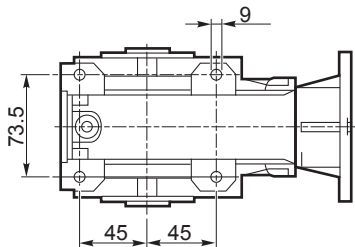
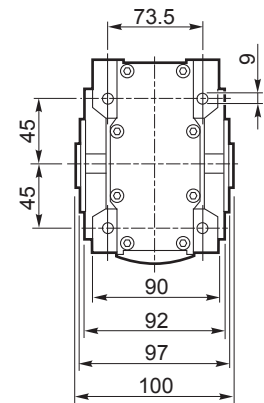
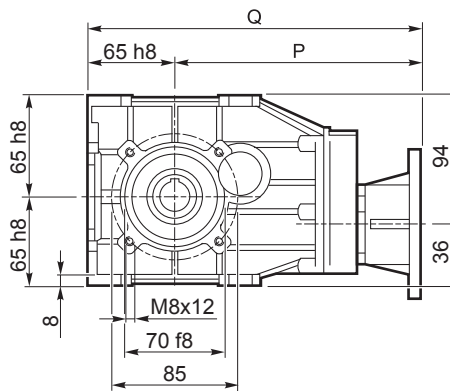
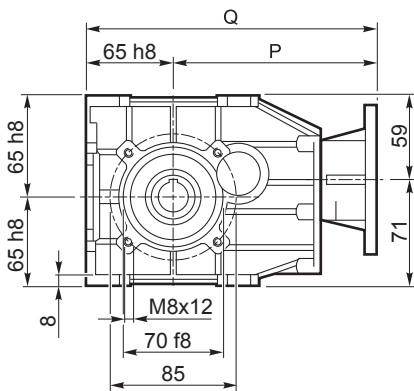
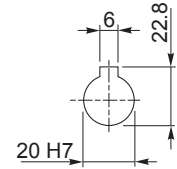
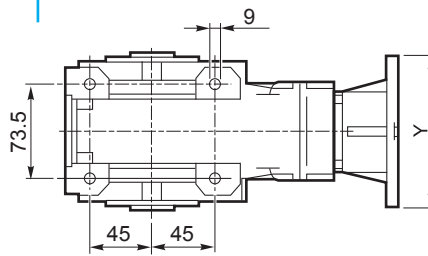
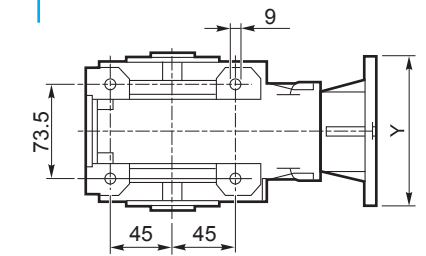

IEC	
	56 B5
	63 B5
	71 B5
	80 B5/B14
	90 B5/B14

B5	GTF...									
	56B					56C				
IEC..	56	63	71	80	90	56	63	71	80	90
Y	120	140	160	200	200	120	140	160	200	200
P	153	156	163	183	183	187	190	197	217	217
Q	218	221	228	248	248	252	255	262	282	282
kg	4.5	4.5	4.5	4.5	4.5	5.0	5.0	5.0	5.0	5.0

B14	GTF...									
	56B					56C				
IEC..	56	63	71	80	90	56	63	71	80	90
Y	—	—	105	120	140	—	—	105	120	140
P	—	—	163	183	183	—	—	197	217	217
Q	—	—	228	248	248	—	—	262	282	282
kg	—	—	4.5	4.5	4.5	—	—	5.0	5.0	5.0

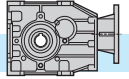

4.13 Dimensiones

4.13 Dimensions

4.13 Dimensions



GTF63B...

GTF63C...

2 Reducciones/Stages/Reduções

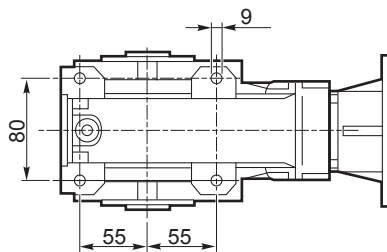
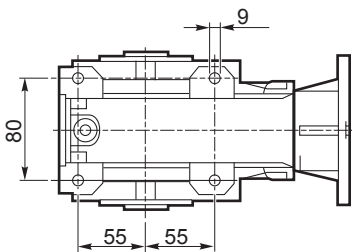
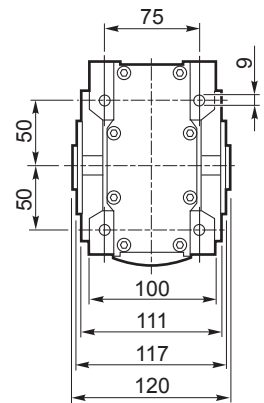
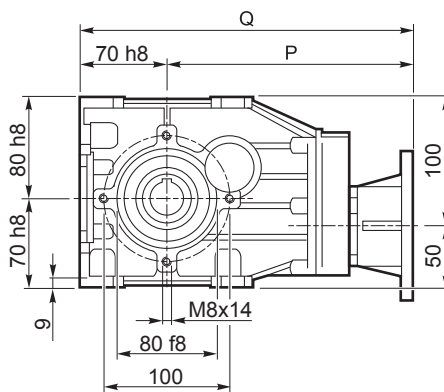
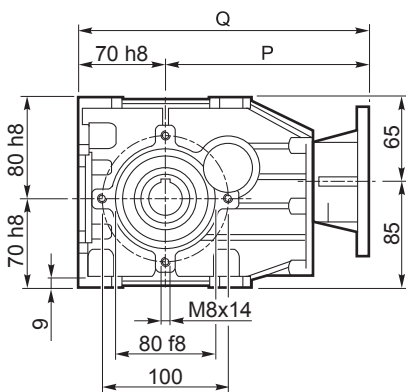
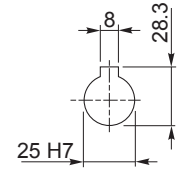
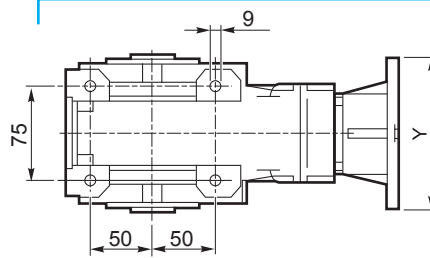
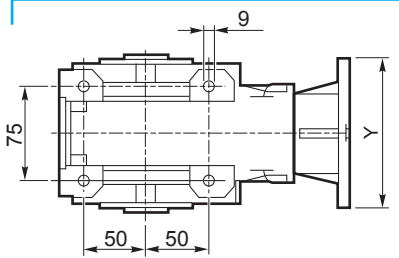
3 Reducciones/Stages/Reduções



IEC	
	
	56 B5
	63 B5
71 B14	71 B5
	80 B5/B14
	90 B5/B14

B5

IEC..	GTF...									
	63B					63C				
56	63	71	80	90	56	63	71	80	90	
Y	120	140	160	200	200	120	140	160	200	200
P	160	163	170	190	190	194	197	204	224	224
Q	230	233	240	260	260	264	267	274	294	294
kg	6.0	6.0	6.0	6.0	6.0	6.5	6.5	6.5	6.5	6.5

B14

IEC..	GTF...									
	63B					63C				
56	63	71	80	90	56	63	71	80	90	
Y	—	—	105	120	140	—	—	105	120	140
P	—	—	170	190	190	—	—	204	224	224
Q	—	—	240	260	260	—	—	274	294	294
kg	—	—	6.0	6.0	6.0	—	—	6.5	6.5	6.5

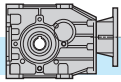

GTF75B...

GTF75C...

2 Reducciones/Stages/Reduccions

3 Reducciones/Stages/Reduccions

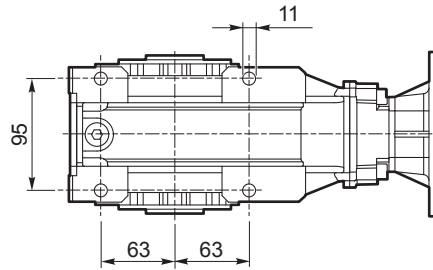
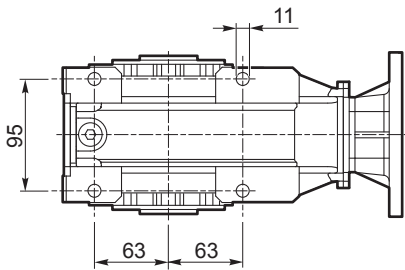
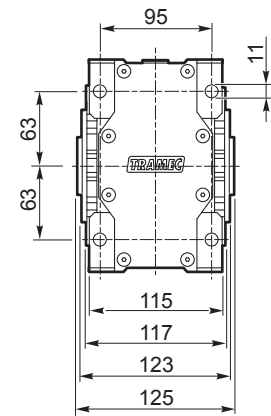
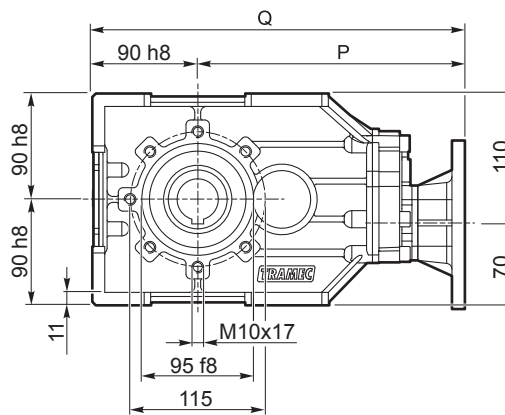
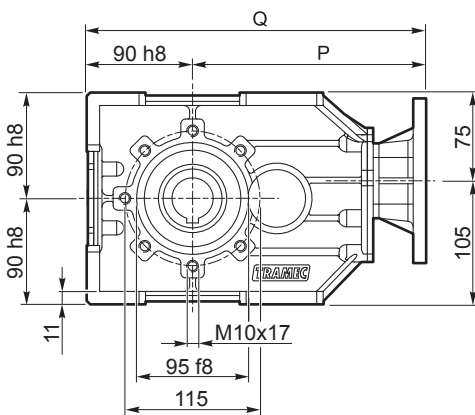
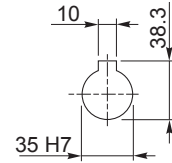
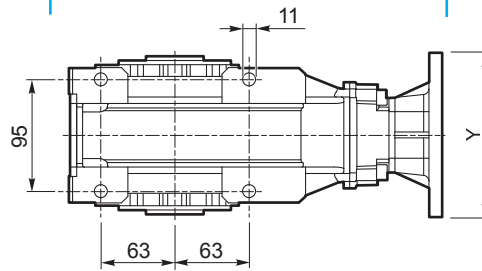
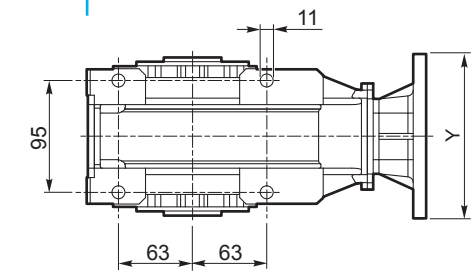

IEC	
	63 B5
71 B14	71 B5
	80 B5/B14
	90 B5/B14
	100 B5/B14

B5	GTF...									
	75B					75C				
IEC..	71	80	90	100	112	63	71	80	90	
Y	160	200	200	250	250	140	160	200	200	
P	205.5	225.5	225.5	235.5	235.5	227	234	254	254	
Q	295.5	315.5	315.5	325.5	325.5	317	324	344	344	
kg	6.5	6.5	6.5	6.5	6.5	7	7	7	7	

B14	GTF...									
	75B					75C				
IEC..	71	80	90	100	112	63	71	80	90	
Y	105	120	140	160	160	-	105	120	140	
P	205.5	225.5	225.5	235.5	235.5	-	234	254	254	
Q	295.5	315.5	315.5	325.5	325.5	-	324	344	344	
kg	6.5	6.5	6.5	6.5	6.5	7	7	7	7	

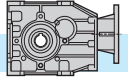

4.13 Dimensiones

4.13 Dimensions

4.13 Dimensions

Brida de salida

Output flange

Bride de sortie

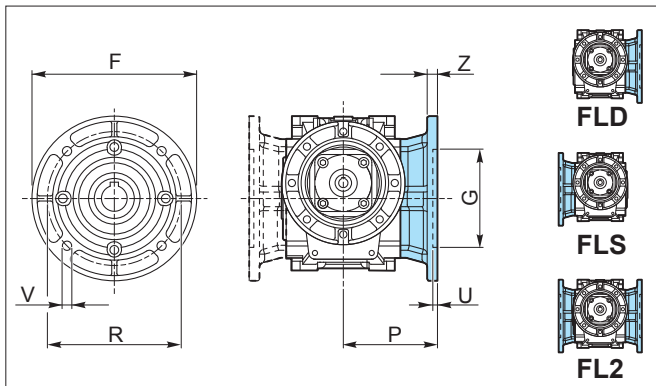

	GT		
	56B 56C	63B 63C	75B 75C
F	140	160	200
G _{F7}	95	110	130
R	115	130	165
P	82	91.5	97.5
U	5	5	5
V	9	9	12
Z	15	10	15
kg	0.5	0.5	0.9

4.15 Lista de recambios

4.15 Spare parts list

4.15 Liste des pièces détachées

Cuando se ordene un recambio, especificar siempre el número particular de cada pieza referenciado en el despiece (ver gráfico de despiece) fecha (1), n° de código (2) y n° variable (3).
(Ver placa de características).

When ordering please specify the spare part number (see exploded view) as well as the date (1), the article number (2) and the variant number (3) (see plate).

Lors de la commande de pièces détachées, toujours rappeler le n° de la pièce (voir plan éclaté), la date (1), le n° de code (2) et le n° de la variante (3).
(Voir plaquette signalétique).

CODIGO: Lista de componentes
CODE: Base list
CODE: Liste du matériel

TIPO: descripción
TYPE: description
TYPE: description

RAP: relación de reducción
RATIO: reduction ratio
RAP: rapport de réduction

VARIANTE:
código alfanumérico
MODEL:
alphanumeric code
VARIANTE:
code alpha numérique

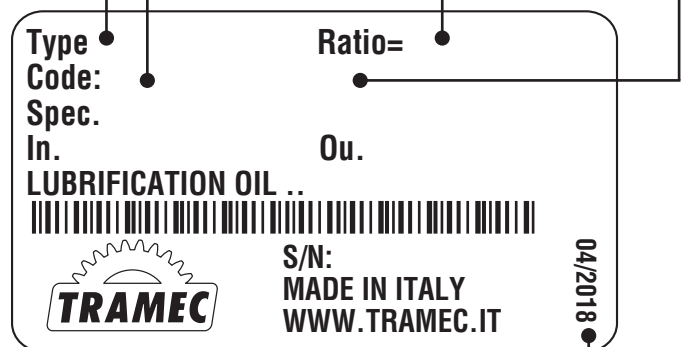

FECHA: mes/año
DATE: month/year
DATE: mois/année

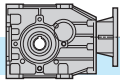

GTF 56B - GTF 63B - GTF 75B

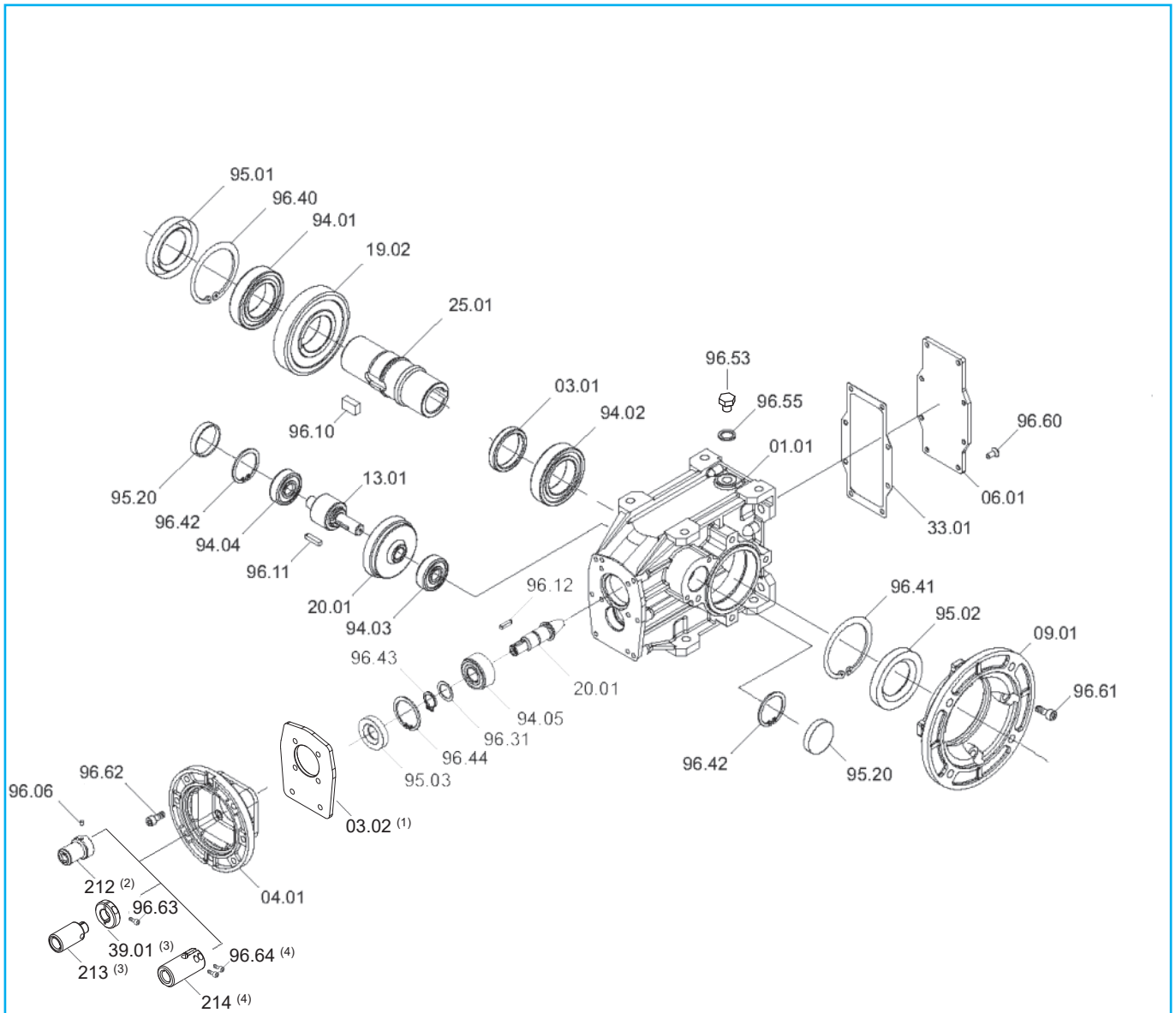

GT	Rodamientos / Bearings / Roulements					Retenes / Oilseals / Bagues d'étanchéité			Reten ciego Closed oil seal Capot
	94.01	94.02	94.03	94.04	94.05	95.01	95.02	95.03	95.20
56B	6007 35/62/14	6007 35/62/14	6201 12/32/10	6201 12/32/10	3201 12/32/15.9	35/62/7	35/62/7	12/32/7	ø 32x7
63B	6008 40/68/15	6008 40/68/15	6301 12/37/12	6301 12/37/12	3202 15/35/15.9	40/68/10	40/68/10	15/35/7	ø 37x7
75B	6010 50/80/16	6010 50/80/16	6203 17/40/12	6203 17/40/12	3202 15/35/15.9	50/80/8	50/80/8	15/35/7	ø 47x7

(1) Solo para GTF75B PAM 71, 80, 90 / Only for GTF75B PAM 71, 80, 90 / seulement pour GT75B PAM 71, 80, 90.

(2) Solo para GTF56B e TF63B PAM 56, 63 / Only for GTF56B and TF63B PAM 56, 63 / seulement pour GTF56B und GTF63B PAM 56, 63.

(3) Solo para GTF56B e TF63B PAM 71, 80, 90 / Only for GTF56B and TF63B PAM 71, 80, 90 / seulement pour GTF56B und GTF63B PAM 71, 80, 90.

(4) Solo para GTF75B tutti i PAM / Only for GTF75B all PAM / seulement pour GTF75B alle PAM.

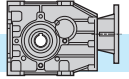

GTF 56C - GTF 63C - GTF 75C

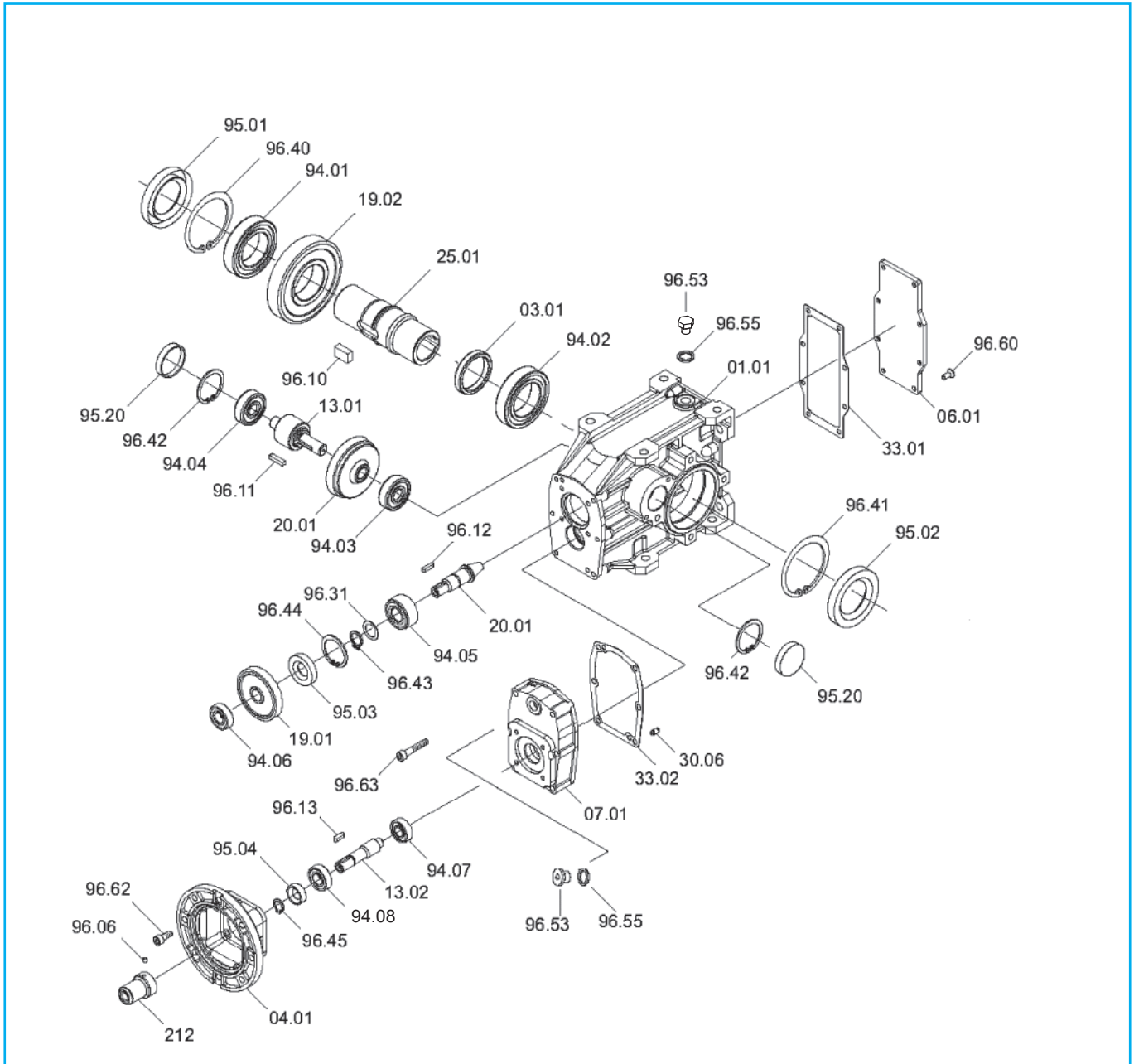

GT	Rodamientos / Bearings / Roulements								Retenes / Oilseals / Bagues d'étanchéité				Reten ciego / Closed oil seal / Capot
	94.01	94.02	94.03	94.04	94.05	94.06	94.07	94.08	95.01	95.02	95.03	95.04	95.20
56C	6007 35/62/14	6007 35/62/14	6201 12/32/10	6201 12/32/10	3201 12/32/15.9	6001 12/28/8	6000 10/26/8	6001 12/28/8	35/62/7	35/62/7	12/32/7	12/22/7	∅ 32x7
63C	6008 40/68/15	6008 40/68/15	6301 12/37/12	6301 12/37/12	3202 15/35/15.9	6001 12/28/8	6000 10/26/8	6001 12/28/8	40/68/10	40/68/10	15/35/7	12/22/7	∅ 37x7
75C	6010 50/80/16	6010 50/80/16	6203 17/40/12	6203 17/40/12	3202 15/35/15.9	6002 16/32/9	6000 10/26/8	6001 12/28/8	50/80/8	50/80/8	15/35/7	12/22/7	∅ 47x7

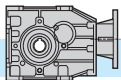

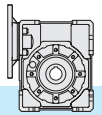

5.0	REDUCTORES TORNILLO SIN FIN GX	GX WORM GEARBOXES	RÉDUCTEUR À ROUE ET VIS SANS FIN GX
5.1	Características	<i>Characteristics</i>	Caractéristiques 78
5.2	Nomenclatura	<i>Designation</i>	Désignation 79
5.3	Rendimiento	<i>Efficiency</i>	Rendement 80
5.4	Irreversibilidad	<i>Irreversibility</i>	Irréversibilité 80
5.5	Juego angular	<i>Backlash</i>	Jeu d'angle 81
5.6	Cargas radiales	<i>Radial load</i>	Charges radiales 82
5.7	Sentido de rotación	<i>Direction of rotation</i>	Sens de rotation 82
5.8	Lubricación y posición de montaje	<i>Lubrication and mounting position</i>	Lubrification et positions de montage 83
5.9	Posición del tablero de Borne	<i>Terminal board position</i>	Position de la boîte à bornes 83
5.10	Datos técnicos	<i>Technical data</i>	Données techniques 84
5.11	Momento de inercia	<i>Moments of inertia</i>	Momento de inercia 90
5.12	Tamaño	<i>Dimensions</i>	Dimensions 91
5.13	Entrada suplementaria	<i>Additional input</i>	Entrée supplémentaire 94
5.14	Accesorios	<i>Accessories</i>	Accessoires 94
5.15	Lista de recambios	<i>Spare parts list</i>	Liste des pièces détachées 95

GHA - MODULAR

La serie MODULAR es la serie base dentro de la gama de reductores GHA.

Las especiales características NANOTECNOLÓGICAS del revestimiento y el diseño básico de la carcasa permiten que la serie MODULAR sea especialmente apta para las aplicaciones en ambientes de la industria ALIMENTARIA (SECO) y FARMACÉUTICA.

Los reductores de la serie GHA MODULAR no están certificados para utilizarse en contacto con alimentos.

GHA - MODULAR

The MODULAR series is the basic series within the range of GHA reducers.

The special NANOTECHNOLOGICAL characteristics of the coating and the basic design of the casing make the MODULAR Series particularly suitable for applications in FOOD (dry environment) and PHARMACEUTICAL sectors.

The GHA MODULAR series reducers are not certified for use in contact with food.

GHA - MODULAR

La serie MODULAR constituye la serie de base au sein de la gamme de réducteurs GHA.

Grâce aux caractéristiques spéciales NANOTECHNOLOGIQUES du revêtement et au design de base de la carcasse, la série MODULAR convient tout particulièrement aux applications dans les environnements ALIMENTAIRE (SEC) et PHARMACEUTIQUE.

Les réducteurs de la série GHA MODULAR ne sont pas certifiés pour l'utilisation au contact des aliments.

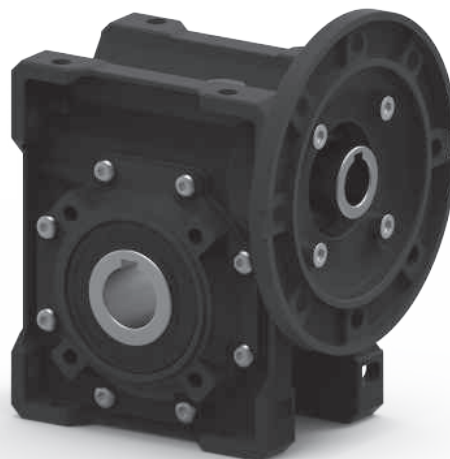

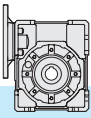

5.1 Características

- Los reductores de tornillo sin fin de la serie GX están disponibles en la versión con preparación para la conexión del motor GXC.
- La ventaja de la serie compacta GXC es su tamaño reducido.
- Las carcasas y las bridas de aleación de aluminio son arenadas y tratadas con la tecnología G.H.A.
- El tornillo sin fin es de acero aleado cementado-templado y rectificado.
- La corona tiene un buje de acero inoxidable AISI 316 y un anillo dentado de bronce GCuSn12.
- El eje hueco de salida se suministra de serie en acero inoxidable AISI 316 y hay una amplia gama de accesorios disponibles: segunda entrada (de acero no inoxidable), brida de salida y brazo de reacción (en aleación de aluminio con tratamiento G.H.A. y montado con tornillos de acero inoxidable)

5.1 Characteristics

- *GX series worm gearboxes are available in the following versions: GXC suitable for motor mounting assembling.*
- *the GX compact version, which actually offers reduced space requirement.*
- *The casings and flanges made of aluminium alloy are sandblasted and treated with G.H.A technology.*
- *The worm shaft is made of hardened-bonded steel and ground.*
- *The wheel has an AISI 316 stainless steel hub with a toothed ring made in bronze GCuSn12.*
- *The hollow output shaft is supplied as standard in AISI 316 stainless steel and there is a wide range of accessories available: second inlet (not in stainless steel), outlet flange and reaction arm (in aluminium alloy with G.H.A treatment and mounted with stainless steel screws).*

5.1 Caractéristiques

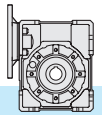

- Les réducteurs à vis sans fin de la série GX sont disponibles dans la version GXC avec agencement pour la fixation du moteur.
- La série compacte GXC a l'avantage de disposer d'un encombrement plus réduit.
- La carcasse et les bridas en alliage d'aluminium sont sablées et traitées avec la technologie G.H.A.
- La vis sans fin, réalisée en acier allié cémenté-trempé, est rectifiée.
- Le moyeu de la couronne est en acier INOX AISI 316 et l'anneau denté en bronze GCuSn12.
- L'arbre de sortie creux de série est fourni en acier INOX AISI 316 et une large gamme d'accessoires est disponible : deuxième entrée (en acier non INOX), bride de sortie et bras de réaction (en alliage d'aluminium avec traitement G.H.A. et monté avec des vis en acier inoxydable).



3.2 Nomenclatura

3.2 Designation

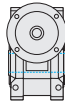
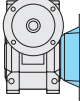
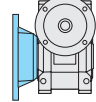
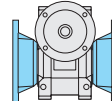
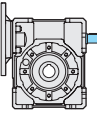
3.2 Désignation

Reductores Gearbox Réducteur	Tipo entrada Input type Type d'entrée	Grandezza Size Größe	Relación redu. Ratio Rapport de réduction	Enganche motor. Motor coupling montage moteur	Posición montaje Mounting position Position Montage	eje de salida de cable Hollow output shaft arbre de sortie de câble	Brida de salida Output flange Bride de sortie	Segunda entrada Additional input Deuxième entrée	Brazo de reacción Torque arm Bras de réaction	Campo de aplicación Field of application Domaine d'application
GX	C	50	10/1	P.A.M	B3	H25	F1S	SeA	BR	A
Reductores de tornillo sin fin Wormgearbox Réducteur à roue et vis sans fin		30 40 50 63 75 89	5 7.5 10 15 20 25 30 40 50 65 80 100	56 63 71 80 90 100 112	B3, B6 B7, B8 V5, V6	H.. 	 F1D-F2D-F3D  F1S-F2S-F3S  F12-F22-F32	 SeA	 BR	A Alimentario y farmacéutico Food and Pharmaceutical Alimentaire et Pharmaceutique M * Marítimo Marine Marin

*: a petición

*: on request

*: sur demande

Tipo entrada

Input type

Type d'entrée

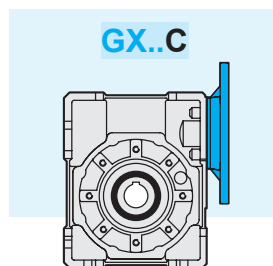

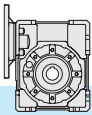

5.3 Rendimiento

Rd - Es el rendimiento dinámico, definido como la relación entre la potencia de salida P_2 y aquella con entrada P_1 . Este depende principalmente de la velocidad de roce, del tipo de lubricante y de la angulación del tornillo. Los valores indicados en las tablas son válidos si se aplica el correspondiente par en salida. Durante la fase de rodaje, aproximadamente las primeras 300 horas de funcionamiento bajo carga, el valor debe ser considerado inferior al 30% respecto al indicado en la tabla.

Rs - Es el rendimiento estático que se obtiene al arrancar el reductor y varía en base a la relación de reducción. Para una correcta elección del reductor a emplear, es importante en las aplicaciones en las cuales no se alcanzan nunca las condiciones de régimen como en los funcionamientos intermitentes. De forma análoga al caso dinámico, también el rendimiento estático durante el rodaje es inferior al 30% respecto al valor indicado en la tabla.

5.3 Efficiency

Rd - *dynamic efficiency, defined as the ratio between P_2 output power and P_1 input power. It mainly depends on the slipping speed, the type of lubricant and the lead angle. The values reported in the table are valid when the corresponding output torque is applied. During the first 300 operating hours under load, the value to be considered is 30% lower than that reported in the table.*

Rs - *static efficiency at gearbox start-up; it changes depending on the reduction ratio.*

Rs value is important for selecting the right gearbox for applications where a steady state is never achieved, as for intermittent duty applications. Same as dynamic efficiency, static efficiency too during the running-in period will be 30% lower than the value reported in the table.

5.3 Rendement

Rd - Le rendement dynamique est le rapport entre la puissance de sortie P_2 et la puissance d'entrée P_1 . Le rendement dépend principalement de la vitesse de glissement, du type de lubrification et de l'angle d'hélice. Les valeurs indiquées dans les tableaux sont valables si l'on applique le couple correspondant à la sortie. En phase de rodage, qui représente environ les 300 premières heures de fonctionnement à pleine charge, la valeur doit être considérée comme étant inférieure de 30% à celle indiquée dans le tableau.

Rs - Il s'agit du rendement statique au démarrage du réducteur. Il varie en fonction du rapport de réduction.

Le R_s est donc important pour choisir le réducteur à utiliser, surtout pour des applications où les conditions de régime ne sont jamais optimales, comme par exemple dans des applications à charges intermittentes. Comme pour le cas dynamique, le rendement statique durant le rodage est lui aussi inférieur de 30% par rapport à la valeur indiquée dans le tableau.

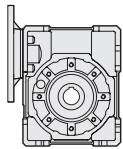

GX	Rs											
	5	7.5	10	15	20	25	30	40	50	65	80	100
30	0.70	0.67	0.62	0.55	0.47	0.43	0.39	0.30	0.27	0.25	0.22	0.21
40	0.69	0.67	0.63	0.55	0.52	0.45	0.40	0.35	0.29	0.26	0.25	0.23
50	0.69	0.68	0.65	0.58	0.53	0.47	0.41	0.37	0.32	0.28	0.25	0.23
63	0.70	0.68	0.65	0.57	0.55	0.50	0.47	0.38	0.33	0.29	0.28	0.23
75	/	0.68	0.65	0.58	0.55	0.51	0.43	0.39	0.35	0.31	0.28	0.24
89	/	0.68	0.65	0.58	0.55	0.52	0.45	0.39	0.36	0.32	0.29	0.25

5.4 Irreversibilidad

En las aplicaciones donde sea necesario evitar la transmisión del movimiento reaccionario o sostener la carga, en ausencia de la alimentación eléctrica, es aconsejable adaptar frenos externos.

En los reductores de tornillo sin fin aparece esta característica natural, denominada grado de irreversibilidad, que crece al aumentar la relación de reducción por estar estrechamente ligado al relativo rendimiento.

Para obtener altos grados de irreversibilidad es necesario adoptar las relaciones de reducción más altas, sin olvidar que el rendimiento tiende a crecer durante las primeras 500 horas de funcionamiento estabilizándose después en los valores indicados en el catálogo.

Irreversibilidad estática

Condiciones para impedir la rotación, comandado por el eje lento, sin excluir posibles retornos lentos en el caso que la carga sea sometida a vibraciones.

Rs < 0.45 se tiene irreversibilidad
Rs = 0.45 ÷ 0.55 irreversibilidad incierta
Rs > 0.55 se tiene reversibilidad

5.4 Irreversibility

The use of external brakes is advised in case of applications where backwards motion must be hindered and the load must be held should the feed be cut off.

Some worm gearboxes feature natural irreversibility. The higher the ratio, the higher is the irreversibility, since it is strictly dependent on the relative efficiency.

In order to achieve high irreversibility it is therefore necessary to select higher efficiency reduction ratios not to forget that the efficiency is growing during the first 500 hours life until it stabilizes to the values mentioned in the catalogue.

Static irreversibility

Static irreversibility occurs when the rotation controlled by the output shaft is hindered; possible slow returns cannot be excluded should the load be subject to vibrations.

Rs < 0.45 provides irreversibility
Rs = 0.45 ÷ 0.55 irreversibility is uncertain
Rs > 0.55 reversibility is possible

5.4 Irréversibilité

En cas d'absence d'alimentation électrique, il est conseillé de choisir des freins extérieurs pour les applications où il faut éviter la transmission du mouvement rétrograde ou bien soutenir la charge.

Le degré d'irréversibilité est une caractéristique naturelle des réducteurs à roue et vis sans fin. Elle augmente en même temps que le rapport de réduction puisqu'elle est liée au rendement.

Pour obtenir d'importants degrés d'irréversibilité, il faut donc utiliser des rapports de réductions plus élevés, sans oublier que le rendement tend à augmenter au bout des 500 premières heures de service pour se stabiliser par la suite aux valeurs mentionnées sur le catalogue.

Irréversibilité statique

Condition qui empêche la rotation commandée par l'arbre de sortie. D'éventuels retours lents ne sont pas à exclure si la charge est soumise à des vibrations.

Rs < 0.45 produit une irréversibilité
Rs = 0.45 ÷ 0.55 irréversibilité incertaine
Rs > 0.55 réversibilité possible

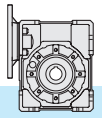

Irreversibilidad dinámica

Condición de detención por lo tanto el soporte de la carga en el momento en que se suspende la acción de comando. La condición es más difícil de obtener cuando es influenciada por el rendimiento dinámico, la velocidad de rotación, posibles vibraciones que la carga puede generar y por la dirección del movimiento en relación de la carga.

Esta última condición es muy evidente en los elevadores: una carga en ascenso, suspendida la acción de comando, debe pararse y asumir una velocidad cero (rendimiento estático) antes de invertir el movimiento y caer por gravedad.

Una carga en descenso, en cambio, tiende a continuar en su movimiento obstruido en caída, por el rendimiento dinámico.

Rd < 0.45 se tiene irreversibilidad
Rd = 0.45 ÷ 0.55 irreversibilidad incierta
Rd > 0.55 se tiene reversibilidad

Dynamic irreversibility

Dynamic irreversibility is characterized by stillstand and hold of the load when the drive stops. It is more difficult to achieve this condition because it is influenced by dynamic efficiency, speed of rotation and possible vibrations generated by the motion direction with regard to the load.

This last condition is much more evident during the lifting: if the drive stops during the lifting of the load this has to come to a speed equals to zero (static irreversibility) before the reversal of motion rotation and its drop for gravity.

On the contrary the load during its descent gets its motion obstructed by its dynamic efficiency.

Rd < 0.45 provides irreversibility
Rd = 0.45 ÷ 0.55 irreversibility is uncertain
Rd > 0.55 reversibility is possible

Irréversibilité dynamique

Condition nécessaire pour arrêter et donc soutenir la charge au moment de l'arrêt de l'action de commande. Cette condition est la plus difficile à obtenir puisqu'elle est influencée par le rendement dynamique, la vitesse de rotation et les rotations éventuelles produites par la charge et la direction du mouvement par rapport à la charge.

Cette dernière condition est particulièrement évidente lors des élévations : une charge en montée, lorsque l'action de commande cesse, doit s'arrêter et sa vitesse est alors égale à zéro (rendement statique) avant d'inverser le mouvement et tomber sous l'effet de la force de gravité.

Une charge en descente a, au contraire, tendance à poursuivre son mouvement, gênée dans sa chute par le rendement dynamique.

Rd < 0.45 produit irréversibilité
Rd = 0.45 ÷ 0.55 irréversibilité incertaine
Rd > 0.55 réversibilité possible

5.5 Juego angular

Juego angular standard

Medido bloqueando el eje de entrada, y girando el eje de salida en las dos direcciones aplicando el par estrictamente necesario para crear el contacto entre los dientes de los engranajes, como máximo igual al 2% del par nominal (T_{2M}).

5.5 Backlash

Backlash

Angular backlash measured after having blocked the input shaft by rotating output shaft in both directions and applying the torque which is strictly necessary to create a contact between the teeth of the gears. The applied torque should be at most 2% of the max. torque (T_{2M}).

5.5 Jeu d'angle

Jeu d'angle standard

Mesuré en bloquant l'arbre d'entrée et en tournant l'arbre dans les deux directions en appliquant le couple strictement nécessaire pour créer le contact avec les dents des engrenages, équivalent à 2% max. du couple nominal (T_{2M}).

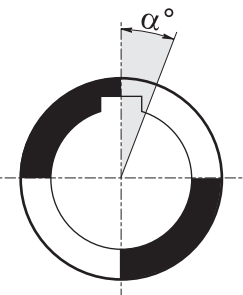

GX						
i_n	30	40	50	63	75	89
	max	max	max	max	max	max
5	16'	13.5'	10.5'	10'	/	/
7.5	16'	13.5'	10.5'	10'	10'	9.5'
10	16'	13.5'	10.5'	10'	10'	9'
15	16'	13.5'	10.5'	10'	10'	9'
20	14.5'	12'	9.5'	8.5'	8.5'	8.5'
25	14.5'	12'	9.5'	8.5'	8.5'	8.5'
30	14.5'	12'	8.5'	8.5'	8.5'	8.5'
40	14.5'	12'	9.5'	8.5'	8.5'	8'
50	14'	12'	9.5'	8.5'	8.5'	8'
65	14'	12'	9'	8'	8'	8'
80	13.5'	11.5'	9'	7.5'	7.5'	7.5'
100	13'	11'	9'	7.5'	7.5'	7.5'

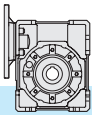

5.6 Carga radial

Carga radial Fr_2 Carga axial Fa_2
en el eje de salida [N]

Si la carga radial en el eje no se aplica a la mitad de la protuberancia del eje, el valor de carga admisible debe evaluarse utilizando la fórmula que se refiere a Fry2, en la cual los valores de a, b y Fr_2 se informan en las tablas relativas a cargas radiales

En los ejes con salida doble, cada extremidad puede soportar una carga radial igual a 3/5 del valor de la tabla, siempre y cuando las cargas aplicables sean de igual intensidad y reaccionen en el mismo sentido.

De lo contrario, póngase en contacto con el servicio técnico.

5.6 Radial load

Fr_2 radial loads and Fa_2 axial loads on the output shaft [N]

Should the radial load affect the shaft not at the half-way point of its projection but at a different point, the value of the admissible load has to be calculated using the Fry₂ formula: a, b and Fr₂ values are reported in the radial load tables.

With regard to double-projecting shafts, the load applicable at each end is 2/3 of the value given in the table, on condition that the applied loads feature same intensity and direction and that they act in the same direction.

Otherwise please contact the technical department.

5.6 Charges radiales

Charge radiale Fr_2 Charge axiale Fa_2
sur le puits de sortie [N]

Si la charge radiale sur l'arbre n'est pas appliquée sur la moitié de la saillie de l'arbre, la valeur de charge admissible doit être évaluée à l'aide de la formule faisant référence à Fry2, dans laquelle les valeurs de a, b et Fr_2 sont rapportées dans les tableaux relatifs à charges radiales.

Pour les arbres dépassant des deux côtés qui tournent dans le même sens et à la même vitesse, chaque extrémité devra supporter une charge radiale égale aux 3/5 des valeurs du tableau.

Sinon, contactez le service technique.

Las cargas radiales que se muestran en las tablas están destinadas a aplicarse en el centro de la extensión del eje y se refieren a las cajas de engranajes que funcionan con el factor de servicio 1.

The radial loads indicated in the chart are considered to be applied at the half-way point of the shaft projection, and refer to gear units operating with service factor 1.

Les charges radiales indiquées dans les tableaux sont destinées à être appliquées au milieu du prolongement d'arbre et font référence à des boîtes de vitesses fonctionnant avec le facteur de service 1.

		GX											
$n_1=1400$ rpm		30		40		50		63		75		89	
i_n	n_2 [rpm]	a = 66.5 b = 49		a = 83.5 b = 60.5		a = 102 b = 73.5		a = 122.5 b = 93.5		a = 134 b = 100		a = 163 b = 118	
		Fr_2	Fa_2	Fr_2	Fa_2	Fr_2	Fa_2	Fr_2	Fa_2	Fr_2	Fa_2	Fr_2	Fa_2
5	280	700	140	1400	280	1400	300	1800	360	/	/	/	/
7.5	187	750	150	1500	300	1650	330	2100	420	2500	500	2600	520
10	140	800	160	1600	320	1800	360	2300	460	2800	560	3000	600
15	93	850	170	1700	340	1950	390	2600	520	3000	600	3400	680
20	70	900	180	1800	360	2200	440	2800	560	3300	660	3800	760
25	56	950	190	1900	380	2400	480	3100	620	3700	740	4100	820
30	47	1000	200	2000	400	2600	520	3400	680	4000	800	4500	900
40	35	1050	210	2100	420	2850	570	3700	740	4400	880	4900	980
50	28	1100	220	2200	440	3100	620	4000	800	4850	970	5300	1060
60	23	1150	230	2400	480	3200	640	4200	840	5000	1000	5600	1120
63	22	1250	250	2500	500	3400	680	4450	890	5300	1060	5900	1180
80	17.5	1350	270	2700	540	3800	760	4900	980	5800	1160	6500	1300
100	14	1500	300	3000	600	4000	800	5400	1080	6500	1300	7000	1400

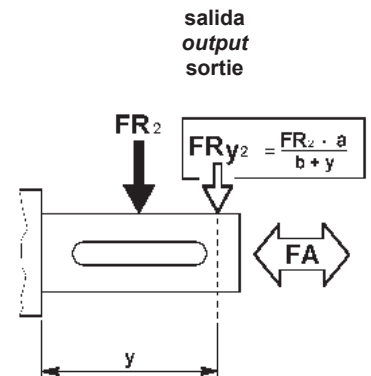

5.7 Sentido de rotación

5.7 Direction of rotation

5.7 Sens de rotation

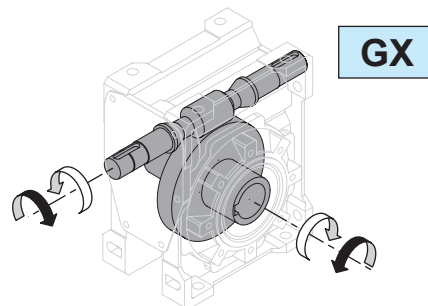

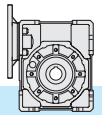

5.8 Lubricación

Los reductores de la serie GX se suministran con lubricante sintético para uso alimentario: FUCHS CASSIDA FLUID 320 OIL.

Se recomienda precisar ordenadamente las fases deseada de la posición de trabajo.

Para obtener más detalles, consulte el apartado 1.6 en la pág. 17.

Posición de montaje

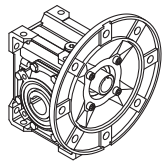

B3

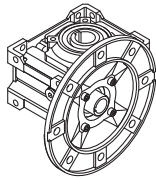

B6

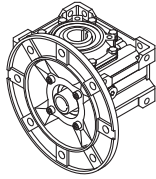

B7

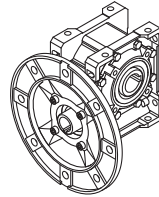

B8

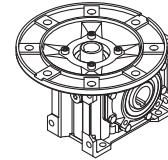

V5

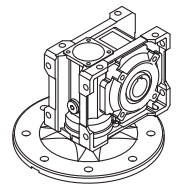

V6

5.8 Lubrication

The GX series worm gearboxes are supplied complete with synthetic lubricant for food use: FUCHS CASSIDA FLUID 320 OIL.

It is recommended to always specify the desired assembly position when placing the order.

For further details, please see page 17 paragraph 1.6

Mounting positions

5.8 Lubrification

Les réducteurs à roue et vis sans fin de la série GX sont fournis dotés de lubrifiant synthétique à usage alimentaire: FUCHS CASSIDA FLUID 320 OIL.

Position de montage à spécifier lors de la commande.

Pour plus de détails, consulter le paragraphe 1.6 à la page 17.

Positions de montage

		Cant. de aceite / Oil quantity / Q.té d'huile [lt]			
		Posizione di montaggio / Mounting position / Positions de montage			
		B3	B6 - B7	B8	V5 - V6
GX	30	0.015	0.030	0.015	
	40	0.040	0.060	0.040	
	50	0.080	0.120	0.080	
	63	0.160	0.220	0.160	
	75	0.260	0.340	0.260	
		89	0.450	0.750	0.450

Hay un solo tapón de llenado del aceite.

Aluminium housings have one oil filling plug only.

Il n'y a qu'un seul bouchon de remplissage de l'huile.

5.9 Posición borne

5.9 Terminal board position

5.9 Position de la boîte à bornes

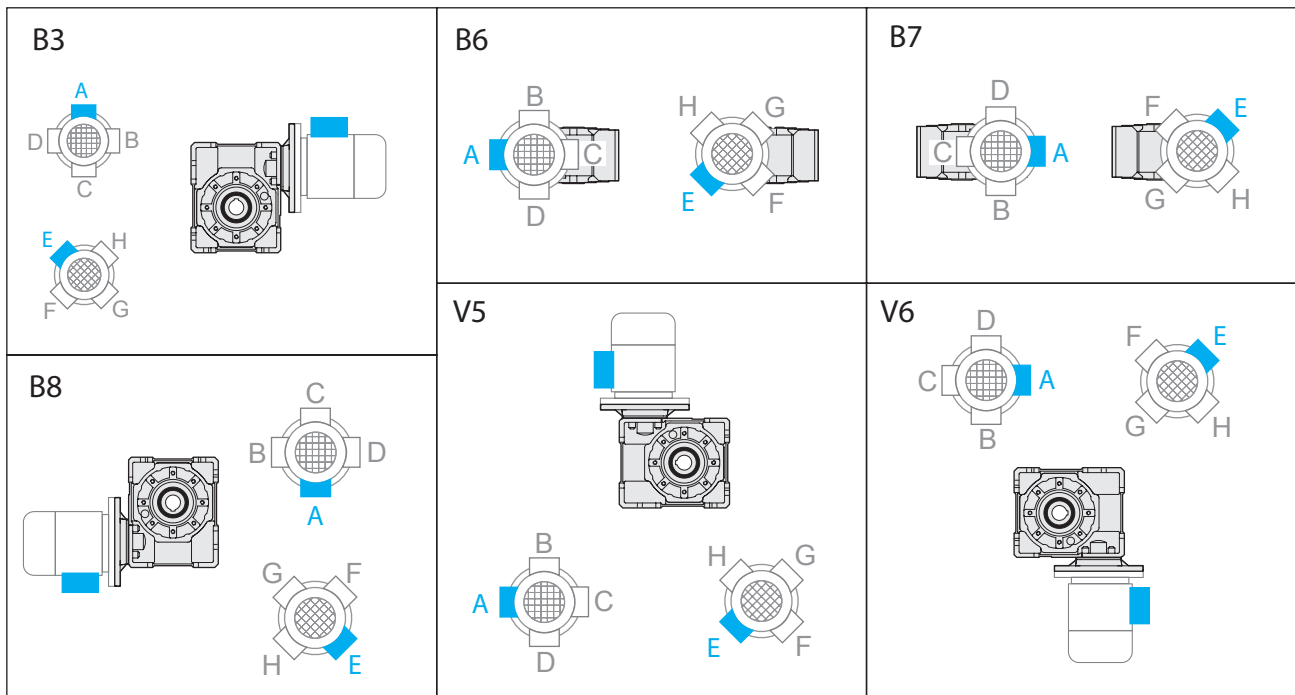

Especificar siempre ordenadamente la posición de montaje y su forma constructiva. Posición borne v. pág. 93 (PM=1; PM=2)

Mounting position always to be specified when ordering. Terminal board position see page 93 (PM=1; PM=2)

Lors de toute commande, il est recommandé de préciser la position de montage et la version désirées. Position de la boîte à bornes v. pag. 93 (PM=1; PM=2)

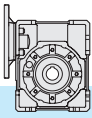

5.10 Datos técnicos

5.10 Technical data

5.10 Données techniques

GXC 30	$n_1 = 2800$				MOTORES / MOTORS / MOTEURS GHA CLASSIC				Input - IEC	
	i_n	n_2 [min ⁻¹]	Rd	P_{t0}	T_2 [Nm]	P_1 [kW]	FS'	B5/B14		
	5	560	0.89	—	5.6	0.37	2.5	63	56	
7.5	373	0.86	8		0.37	2.0				
10	280	0.84	11		0.37	1.5				
15	187	0.81	15		0.37	1.1				
20	140	0.76	13		0.25	1.2				
25	112	0.74	16		0.25	1.0				
30	93	0.71	13		0.18	1.0				
40	70	0.65	16		0.18	1.0				
50	56	0.62	14		0.13	1.1				
65	43	0.57	17		0.13	1.0				
80	35	0.54	13		0.09	1.0				
100	28	0.52	16	0.09	0.8	—	—			



1.4

GXC 30	$n_1 = 1400$				MOTORES / MOTORS / MOTEURS GHA CLASSIC				Input - IEC	
	i_n	n_2 [min ⁻¹]	Rd	P_{t0}	T_2 [Nm]	P_1 [kW]	FS'	B5/B14		
	5	280	0.87	0.40	6.5	0.22	2.9	63	56	
7.5	187	0.84	0.40	9	0.22	2.2				
10	140	0.82	0.40	12	0.22	1.8				
15	93	0.77	0.30	17	0.22	1.3				
20	70	0.72	0.20	18	0.18	1.1				
25	56	0.69	0.20	21	0.18	1.0				
30	47	0.66	0.20	18	0.13	1.1				
40	35	0.59	0.20	21	0.13	1.0				
50	28	0.55	0.20	17	0.09	1.1				
65	22	0.51	0.10	20	0.09	1.0				
80	18	0.48	0.10	16	0.06	1.0				
100	14	0.45	0.10	18	0.06	0.8	—	—		



1.4

GXC 30	$n_1 = 900$				MOTORES / MOTORS / MOTEURS GHA CLASSIC				Input - IEC	
	i_n	n_2 [min ⁻¹]	Rd	P_{t0}	T_2 [Nm]	P_1 [kW]	FS'	B5/B14		
	5	180	0.85	—	5.9	0.13	3.9	63	56	
7.5	120	0.82	9		0.13	2.9				
10	90	0.80	11		0.13	2.3				
15	60	0.75	15		0.13	1.6				
20	45	0.69	19		0.13	1.2				
25	36	0.66	23		0.13	1.1				
30	30	0.63	18		0.09	1.2				
40	23	0.55	21		0.09	1.1				
50	18	0.52	16		0.06	1.1				
65	14	0.48	20		0.06	1.1				
80	11	0.44	11		0.03	1.7				
100	9	0.42	13	0.03	1.1	—	—			



1.4

GXC 30	$n_1 = 500$				MOTORES / MOTORS / MOTEURS GHA CLASSIC				Input - IEC	
	i_n	n_2 [min ⁻¹]	Rd	P_{t0}	T_2 [Nm]	P_1 [kW]	FS'	B5/B14		
	5	100	0.83	—	—	—	—	63	56	
7.5	67	0.80	—		—	—				
10	50	0.77	—		—	—				
15	33	0.72	—		—	—				
20	25	0.66	—		—	—				
25	20	0.62	—		—	—				
30	17	0.59	—		—	—				
40	13	0.51	—		—	—				
50	10	0.48	—		—	—				
65	8	0.43	—		—	—				
80	6	0.40	—		—	—				
100	5	0.38	—	—	—	—	—			



1.4

* **ATENCIÓN:** el par máximo utilizable [T_{2M}] deberá calcularse con respecto al factor de servicio: $T_{2M} = T_2 \times FS'$

* **WARNING:** Maximum allowable torque [T_{2M}] must be calculated using the following service factor: $T_{2M} = T_2 \times FS'$

* **ATTENTION :** le couple maximum admissible [T_{2M}] se calcule en utilisant le facteur de service suivant : $T_{2M} = T_2 \times FS'$

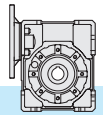

5.10 Datos técnicos

5.10 Technical data

5.10 Données techniques

GXC 40	$n_1 = 2800$				MOTORES / MOTORS / MOTEURS GHA CLASSIC							
	i_n	n_2 [min ⁻¹]	Rd	P_{10}	T_2 [Nm]	P_1 [kW]	FS'	Input - IEC				
								B5/B14				
Kg 2.4	5	560	0.88	—	11.3	0.75	2.2	71	63	—		
	7.5	373	0.87		17	0.75	1.8					
	10	280	0.86		22	0.75	1.4					
	15	187	0.82		32	0.75	1.0					
	20	140	0.80		30	0.55	1.0					
	25	112	0.76		24	0.37	1.1					
	30	93	0.73		28	0.37	1.3					
	40	70	0.70		24	0.25	1.4					
	50	56	0.65		28	0.25	1.1					
	65	43	0.61		24	0.18	1.2					
	80	35	0.58		21	0.13	1.3					
	100	28	0.55		24	0.13	1.0					
							—		56			

GXC 40	$n_1 = 1400$				MOTORES / MOTORS / MOTEURS GHA CLASSIC							
	i_n	n_2 [min ⁻¹]	Rd	P_{10}	T_2 [Nm]	P_1 [kW]	FS'	Input - IEC				
								B5/B14				
Kg 2.4	5	280	0.87	0.80	16.3	0.55	2.1	71	63	—		
	7.5	187	0.85	0.80	24	0.55	1.7					
	10	140	0.83	0.70	31	0.55	1.3					
	15	93	0.79	0.50	30	0.37	1.4					
	20	70	0.76	0.50	38	0.37	1.0					
	25	56	0.72	0.40	31	0.25	1.1					
	30	47	0.68	0.40	35	0.25	1.2					
	40	35	0.64	0.30	38	0.22	1.0					
	50	28	0.59	0.30	36	0.18	1.1					
	65	22	0.54	0.20	31	0.13	1.1					
	80	18	0.52	0.20	31	0.11	1.1					
	100	14	0.49	0.20	30	0.09	0.9					
							—		56			

GXC 40	$n_1 = 900$				MOTORES / MOTORS / MOTEURS GHA CLASSIC							
	i_n	n_2 [min ⁻¹]	Rd	P_{10}	T_2 [Nm]	P_1 [kW]	FS'	Input - IEC				
								B5/B14				
Kg 2.4	5	180	0.85	—	16.7	0.37	2.5	71	63	—		
	7.5	120	0.83		25	0.37	2.0					
	10	90	0.81		32	0.37	1.5					
	15	60	0.76		45	0.37	1.1					
	20	45	0.74		39	0.25	1.2					
	25	36	0.69		33	0.18	1.3					
	30	30	0.65		37	0.18	1.3					
	40	23	0.61		33	0.13	1.3					
	50	18	0.55		38	0.13	1.1					
	65	14	0.51		32	0.09	1.2					
	80	11	0.48		37	0.09	1.0					
	100	9	0.45		29	0.06	1.0					
							—		56			

GXC 40	$n_1 = 500$				MOTORES / MOTORS / MOTEURS GHA CLASSIC							
	i_n	n_2 [min ⁻¹]	Rd	P_{10}	T_2 [Nm]	P_1 [kW]	FS'	Input - IEC				
								B5/B14				
Kg 2.4	5	100	0.83	—	7.1	0.09	7.1	71	63	—		
	7.5	67	0.81		10	0.09	5.5					
	10	50	0.79		14	0.09	4.4					
	15	33	0.73		19	0.09	3.1					
	20	25	0.70		24	0.09	2.3					
	25	20	0.65		28	0.09	1.7					
	30	17	0.61		31	0.09	1.8					
	40	13	0.57		39	0.09	1.3					
	50	10	0.51		44	0.09	1.2					
	65	8	0.46		52	0.09	0.9					
	80	6	0.44		61*	0.09	0.7*					
	100	5	0.41		71*	0.09	0.4*					
							—		56			

* **ATENCIÓN:** el par máximo utilizable [T_{2M}] deberá calcularse con respecto al factor de servicio: $T_{2M} = T_2 \times FS'$

* **WARNING:** Maximum allowable torque [T_{2M}] must be calculated using the following service factor: $T_{2M} = T_2 \times FS'$

* **ATTENTION :** le couple maximum admissible [T_{2M}] se calcule en utilisant le facteur de service suivant : $T_{2M} = T_2 \times FS'$

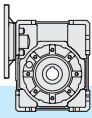

5.10 Datos técnicos

5.10 Technical data

5.10 Données techniques

GXC 50	$n_1 = 2800$				MOTORES / MOTORS / MOTEURS GHA CLASSIC							
	i_n	n_2 [min ⁻¹]	Rd	P_{10}	T_2 [Nm]	P_1 [kW]	FS'	Input - IEC				
								B5/B14				
 4.0	5	560	0.89	—	22.8	1.5	1.9	80	71	—		
	7.5	373	0.88		34	1.5	1.5					
	10	280	0.86		44	1.5	1.2					
	15	187	0.84		47	1.1	1.2					
	20	140	0.81		42	0.75	1.4					
	25	112	0.78		50	0.75	1.0					
	30	93	0.75		42	0.55	1.3					
	40	70	0.72		54	0.55	1.0					
	50	56	0.68		43	0.37	1.3					
	65	43	0.64		53	0.37	1.0					
	80	35	0.61		41	0.25	1.2					
	100	28	0.58		35	0.18	1.3					
							—		63			

GXC 50	$n_1 = 1400$				MOTORES / MOTORS / MOTEURS GHA CLASSIC							
	i_n	n_2 [min ⁻¹]	Rd	P_{10}	T_2 [Nm]	P_1 [kW]	FS'	Input - IEC				
								B5/B14				
 4.0	5	280	0.87	1.2	26.7	0.9	2.3	80	71	—		
	7.5	187	0.86	1.2	40	0.9	1.8					
	10	140	0.84	1.0	52	0.9	1.4					
	15	93	0.80	0.80	74	0.9	1.0					
	20	70	0.78	0.70	58	0.55	1.3					
	25	56	0.74	0.60	47	0.37	1.4					
	30	47	0.71	0.60	53	0.37	1.2					
	40	35	0.67	0.50	68	0.37	1.0					
	50	28	0.62	0.40	53	0.25	1.3					
	65	22	0.58	0.40	64	0.25	1.0					
	80	18	0.54	0.40	53	0.18	1.1					
	100	14	0.51	0.30	45	0.13	1.2					
							—		63			

GXC 50	$n_1 = 900$				MOTORES / MOTORS / MOTEURS GHA CLASSIC							
	i_n	n_2 [min ⁻¹]	Rd	P_{10}	T_2 [Nm]	P_1 [kW]	FS'	Input - IEC				
								B5/B14				
 4.0	5	180	0.85	—	33.8	0.75	2.2	80	71	—		
	7.5	120	0.84		50	0.75	1.6					
	10	90	0.82		66	0.75	1.3					
	15	60	0.78		68	0.55	1.3					
	20	45	0.75		59	0.37	1.5					
	25	36	0.71		70	0.37	1.1					
	30	30	0.67		79	0.37	1.0					
	40	23	0.63		67	0.25	1.1					
	50	18	0.59		78	0.25	1.0					
	65	14	0.54		67	0.18	1.1					
	80	11	0.51		56	0.13	1.2					
	100	9	0.47		45	0.09	1.3					
							—		63			

GXC 50	$n_1 = 500$				MOTORES / MOTORS / MOTEURS GHA CLASSIC							
	i_n	n_2 [min ⁻¹]	Rd	P_{10}	T_2 [Nm]	P_1 [kW]	FS'	Input - IEC				
								B5/B14				
 4.0	5	100	0.84	—	14.3	0.18	6.4	80	71	—		
	7.5	67	0.82		21	0.18	4.7					
	10	50	0.80		28	0.18	3.8					
	15	33	0.75		39	0.18	2.7					
	20	25	0.72		50	0.18	2.1					
	25	20	0.68		58	0.18	1.5					
	30	17	0.63		65	0.18	1.5					
	40	13	0.59		81	0.18	1.2					
	50	10	0.54		93	0.18	1.0					
	65	8	0.50		56	0.09	1.5					
	80	6	0.46		63	0.09	1.2					
	100	5	0.43		74	0.09	0.8					
							—		63			

* **ATENCION:** el par máximo utilizable [T_{2M}] deberá calcularse con respecto al factor de servicio: $T_{2M} = T_2 \times FS'$

* **WARNING:** Maximum allowable torque [T_{2M}] must be calculated using the following service factor: $T_{2M} = T_2 \times FS'$

* **ATTENTION :** le couple maximum admissible [T_{2M}] se calcule en utilisant le facteur de service suivant : $T_{2M} = T_2 \times FS'$

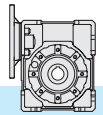

5.10 Datos técnicos

5.10 Technical data

5.10 Données techniques

GXC 63	$n_1 = 2800$				MOTORES / MOTORS / MOTEURS GHA CLASSIC						
	i_n	n_2 [min ⁻¹]	Rd	P_{10}	T_2 [Nm]	P_1 [kW]	FS'	Input - IEC			
								B5/B14			
Kg 6.6	5	560	0.89	—	45.5	3	1.7	90	80	—	
	7.5	373	0.88		68	3	1.3				
	10	280	0.87		89	3	1.1				
	15	187	0.84		95	2.2	1.0				
	20	140	0.83		85	1.5	1.3				
	25	112	0.81		76	1.1	1.2				
	30	93	0.77		87	1.1	1.3				
	40	70	0.74		111	1.1	1.1	—	71		
	50	56	0.70		90	0.75	1.1				
	65	43	0.67		81	0.55	1.2				
	80	35	0.64		65	0.37	1.4				
	100	28	0.60		75	0.37	1.1				

GXC 63	$n_1 = 1400$				MOTORES / MOTORS / MOTEURS GHA CLASSIC						
	i_n	n_2 [min ⁻¹]	Rd	P_{10}	T_2 [Nm]	P_1 [kW]	FS'	Input - IEC			
								B5/B14			
Kg 6.6	5	280	0.88	1.8	54	1.8	2.0	90	80	—	
	7.5	187	0.87	1.8	80	1.8	1.5				
	10	140	0.85	1.6	105	1.8	1.2				
	15	93	0.81	1.2	125	1.5	1.1				
	20	70	0.80	1.2	120	1.1	1.2				
	25	56	0.77	1.0	118	0.9	1.0				
	30	47	0.73	0.90	134	0.9	1.1				
	40	35	0.69	0.80	142	0.75	1.1	—	71		
	50	28	0.65	0.70	122	0.55	1.0				
	65	22	0.61	0.60	100	0.37	1.2				
	80	18	0.58	0.60	79	0.25	1.4				
	100	14	0.53	0.50	91	0.25	1.1				

GXC 63	$n_1 = 900$				MOTORES / MOTORS / MOTEURS GHA CLASSIC						
	i_n	n_2 [min ⁻¹]	Rd	P_{10}	T_2 [Nm]	P_1 [kW]	FS'	Input - IEC			
								B5/B14			
Kg 6.6	5	180	0.87	—	69	1.5	1.9	90	80	—	
	7.5	120	0.85		102	1.5	1.4				
	10	90	0.83		133	1.5	1.1				
	15	60	0.79		139	1.1	1.1				
	20	45	0.77		123	0.75	1.4				
	25	36	0.74		109	0.55	1.3				
	30	30	0.70		122	0.55	1.3				
	40	23	0.66		154	0.55	1.1	—	71		
	50	18	0.61		120	0.37	1.2				
	65	14	0.57		98	0.25	1.4				
	80	11	0.54		115	0.25	1.1				
	100	9	0.50		95	0.18	1.2				

GXC 63	$n_1 = 500$				MOTORES / MOTORS / MOTEURS GHA CLASSIC						
	i_n	n_2 [min ⁻¹]	Rd	P_{10}	T_2 [Nm]	P_1 [kW]	FS'	Input - IEC			
								B5/B14			
Kg 6.6	5	100	0.85	—	20	0.25	8.3	90	80	—	
	7.5	67	0.83		30	0.25	5.9				
	10	50	0.81		39	0.25	4.7				
	15	33	0.76		55	0.25	3.4				
	20	25	0.74		71	0.25	2.8				
	25	20	0.71		85	0.25	1.9				
	30	17	0.65		94	0.25	2.1				
	40	13	0.62		118	0.25	1.7	—	71		
	50	10	0.56		135	0.25	1.2				
	65	8	0.52		163	0.25	1.0				
	80	6	0.50		137	0.18	1.1				
	100	5	0.45		77	0.09	1.6				

* ATENCION: el par máximo utilizable [T_{2M}] deberá calcularse con respecto al factor de servicio: $T_{2M} = T_2 \times FS'$

* WARNING: Maximum allowable torque [T_{2M}] must be calculated using the following service factor: $T_{2M} = T_2 \times FS'$

*ATTENTION : le couple maximum admissible [T_{2M}] se calcule en utilisant le facteur de service suivant : $T_{2M} = T_2 \times FS'$

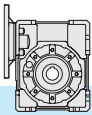

5.10 Datos técnicos

5.10 Technical data

5.10 Données techniques

GXC 75	$n_1 = 2800$				MOTORES / MOTORS / MOTEURS GHA CLASSIC						
	i_n	n_2 [min ⁻¹]	Rd	P_{t0}	T_2 [Nm]	P_1 [kW]	FS'	Input - IEC B5/B14			
 9.5	7.5	373	0.89	—	125	5.5	1.0	112 100	90	—	—
	10	280	0.88		120	4	1.2				
	15	187	0.85		131	3	1.2				
	20	140	0.84		171	3	1.0				
	25	112	0.82		154	2.2	1.0				
	30	93	0.78		120	1.5	1.4				
	40	70	0.75		154	1.5	1.2	—	80	71	
	50	56	0.73		136	1.1	1.2				
	65	43	0.69		114	0.75	1.4				
	80	35	0.66		135	0.75	1.1				
	100	28	0.62		159	0.75	0.8				

GXC 75	$n_1 = 1400$				MOTORES / MOTORS / MOTEURS GHA CLASSIC						
	i_n	n_2 [min ⁻¹]	Rd	P_{t0}	T_2 [Nm]	P_1 [kW]	FS'	Input - IEC B5/B14			
 9.5	7.5	187	0.87	2.5	178	4	1.0	112 100	90	—	—
	10	140	0.86	2.3	176	3	1.1				
	15	93	0.83	1.9	187	2.2	1.1				
	20	70	0.81	1.7	199	1.8	1.1				
	25	56	0.78	1.5	200	1.5	1.0				
	30	47	0.74	1.2	167	1.1	1.3				
	40	35	0.71	1.1	213	1.1	1.1	—	80	71	
	50	28	0.67	1.0	206	0.9	1.0				
	65	22	0.63	0.90	154	0.55	1.3				
	80	18	0.60	0.80	180	0.55	1.0				
	100	14	0.56	0.70	210	0.55	0.8				

GXC 75	$n_1 = 900$				MOTORES / MOTORS / MOTEURS GHA CLASSIC						
	i_n	n_2 [min ⁻¹]	Rd	P_{t0}	T_2 [Nm]	P_1 [kW]	FS'	Input - IEC B5/B14			
 9.5	7.5	120	0.86	—	205	3	1.0	112 100	90	—	—
	10	90	0.84		197	2.2	1.2				
	15	60	0.81		231	1.8	1.0				
	20	45	0.78		250	1.5	1.1				
	25	36	0.76		221	1.1	1.1				
	30	30	0.71		249	1.1	1.0				
	40	23	0.67		214	0.75	1.3	—	80	71	
	50	18	0.64		186	0.55	1.3				
	65	14	0.59		151	0.37	1.5				
	80	11	0.56		177	0.37	1.2				
	100	9	0.52		203	0.37	0.9				

GXC 75	$n_1 = 500$				MOTORES / MOTORS / MOTEURS GHA CLASSIC						
	i_n	n_2 [min ⁻¹]	Rd	P_{t0}	T_2 [Nm]	P_1 [kW]	FS'	Input - IEC B5/B14			
 9.5	7.5	67	0.84	—	90	0.75	2.9	112 100	90	—	—
	10	50	0.82		118	0.75	2.4				
	15	33	0.78		167	0.75	1.7				
	20	25	0.75		216	0.75	1.5				
	25	20	0.72		260	0.75	1.1				
	30	17	0.67		288	0.75	1.1				
	40	13	0.63		265	0.55	1.2	—	80	71	
	50	10	0.59		210	0.37	1.3				
	65	8	0.55		251	0.37	1.0				
	80	6	0.52		197	0.25	1.2				
	100	5	0.47		161	0.18	1.3				

* **ATENCIÓN:** el par máximo utilizable [T_{2M}] deberá calcularse con respecto al factor de servicio: $T_{2M} = T_2 \times FS'$

* **WARNING:** Maximum allowable torque [T_{2M}] must be calculated using the following service factor: $T_{2M} = T_2 \times FS'$

* **ATTENTION :** le couple maximum admissible [T_{2M}] se calcule en utilisant le facteur de service suivant : $T_{2M} = T_2 \times FS'$

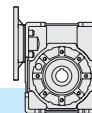

5.10 Datos técnicos

5.10 Technical data

5.10 Données techniques

GXC 89	$n_1 = 2800$				MOTORES / MOTORS / MOTEURS GHA CLASSIC							
	i_n	n_2 [min ⁻¹]	Rd	P_{10}	T_2 [Nm]	P_1 [kW]	FS'	Input - IEC				
								B5/B14				
Kg 23.6	7.5	373	0.89	—	171	7.5	1.2	112 100	90	—		
	10	280	0.88		165	5.5	1.3					
	15	187	0.86		241	5.5	1.0					
	20	140	0.84		230	4	1.2					
	25	112	0.83		212	3	1.2					
	30	93	0.79		243	3	1.1					
	40	70	0.77		230	2.2	1.3	—	80			
	50	56	0.74		278	2.2	1.0					
	65	43	0.71		235	1.5	1.1					
	80	35	0.68		205	1.1	1.2					
100	28	0.64	163	0.75	1.3							

GXC 89	$n_1 = 1400$				MOTORES / MOTORS / MOTEURS GHA CLASSIC							
	i_n	n_2 [min ⁻¹]	Rd	P_{10}	T_2 [Nm]	P_1 [kW]	FS'	Input - IEC				
								B5/B14				
Kg 23.6	7.5	187	0.88	3.0	247	5.5	1.2	112 100	90	—		
	10	140	0.86	2.5	236	4	1.3					
	15	93	0.84	2.2	256	3	1.2					
	20	70	0.82	2.0	334	3	1.1					
	25	56	0.80	1.8	299	2.2	1.1					
	30	47	0.76	1.5	340	2.2	1.0					
	40	35	0.72	1.3	355	1.8	1.1	—	80			
	50	28	0.69	1.1	353	1.5	1.0					
	65	22	0.65	1.0	317	1.1	1.0					
	80	18	0.63	1.0	309	0.9	1.0					
100	14	0.58	0.80	217	0.55	1.2						

GXC 89	$n_1 = 900$				MOTORES / MOTORS / MOTEURS GHA CLASSIC							
	i_n	n_2 [min ⁻¹]	Rd	P_{10}	T_2 [Nm]	P_1 [kW]	FS'	Input - IEC				
								B5/B14				
Kg 23.6	7.5	120	0.86	—	206	3	1.7	112 100	90	—		
	10	90	0.85		270	3	1.3					
	15	60	0.82		286	2.2	1.3					
	20	45	0.79		371	2.2	1.1					
	25	36	0.77		369	1.8	1.0					
	30	30	0.73		416	1.8	1.0					
	40	23	0.69		440	1.5	1.0	—	80			
	50	18	0.66		384	1.1	1.0					
	65	14	0.62		319	0.75	1.1					
	80	11	0.59		274	0.55	1.2					
100	9	0.54	313	0.55	1.0							

GXC 89	$n_1 = 500$				MOTORES / MOTORS / MOTEURS GHA CLASSIC							
	i_n	n_2 [min ⁻¹]	Rd	P_{10}	T_2 [Nm]	P_1 [kW]	FS'	Input - IEC				
								B5/B14				
Kg 23.6	7.5	67	0.84	—	91	0.75	4.7	112 100	90	—		
	10	50	0.83		118	0.75	3.7					
	15	33	0.79		169	0.75	2.7					
	20	25	0.76		219	0.75	2.3					
	25	20	0.74		265	0.75	1.7					
	30	17	0.68		294	0.75	1.6					
	40	13	0.65		371	0.75	1.4	—	80			
	50	10	0.61		439	0.75	1.1					
	65	8	0.57		388	0.55	1.1					
	80	6	0.54		305	0.37	1.3					
100	5	0.49	344	0.37	1.0							

* ATENCION: el par máximo utilizable $[T_{2M}]$ deberá calcularse con respecto al factor de servicio: $T_{2M} = T_2 \times FS'$

* WARNING: Maximum allowable torque $[T_{2M}]$ must be calculated using the following service factor: $T_{2M} = T_2 \times FS'$

*ATTENTION : le couple maximum admissible $[T_{2M}]$ se calcule en utilisant le facteur de service suivant : $T_{2M} = T_2 \times FS'$

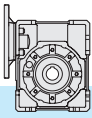

5.11 **Momento de inercia** [Kg·cm²]
(referido al eje rápido de entrada)

5.11 **Moments of inertia** [Kg·cm²]
(referred to input shaft)

5.11 **Moments d'inertie** [Kg·cm²]
(se rapportant à l'arbre d'entrée)

GX30	i_n	GXC	
		B5 - B14	
		IEC 56	IEC 63
5		0.130	0.127
7.5		0.112	0.109
10		0.103	0.100
15		0.097	0.094
20		0.095	0.092
25		0.094	0.091
30		0.093	0.090
40		0.093	0.090
50		0.092	0.089
65		0.079	-
80		0.079	-
100		0.078	-

GX63	i_n	GXC		
		B5 - B14		
		IEC 71	IEC 80	IEC 90
5		-	2.431	2.671
7.5		-	1.949	2.269
10		-	1.744	2.063
15		-	1.597	1.916
20		-	1.545	1.864
25		-	1.514	1.833
30		-	1.508	1.828
40		0.966	1.495	-
50		0.959	1.488	-
65		0.955	1.484	-
80		0.953	1.482	-
100		0.952	1.481	-

GX40	i_n	GXC		
		B5 - B14		
		IEC 56	IEC 63	IEC 71
5		-	0.391	0.463
7.5		-	0.321	0.356
10		-	0.272	0.347
15		-	0.266	0.340
20		-	0.263	0.338
25		-	0.262	0.337
30		-	0.262	0.337
40		-	0.261	0.336
50		0.182	0.261	-
65		0.182	0.261	-
80		0.182	0.261	-
100		0.182	0.261	-

GX75	i_n	GXC			
		B5 - B14			
		IEC 71	IEC 80	IEC 90	IEC 100-112
7.5		-	-	3.712	4.462
10		-	-	3.234	3.984
15		-	-	2.893	3.643
20		-	-	2.774	3.523
25		-	-	2.709	3.458
30		1.615	1.575	2.689	3.438
40		-	1.573	2.659	-
50		-	1.570	2.642	-
65		1.609	1.569	2.633	-
80		1.605	1.565	2.629	-
100		1.602	1.562	2.626	-

GX50	i_n	GXC		
		B5 - B14		
		IEC 63	IEC 71	IEC 80
5		-	0.922	1.046
7.5		-	0.684	0.935
10		-	0.602	0.853
15		-	0.543	0.794
20		-	0.523	0.774
25		-	0.513	0.764
30		-	0.508	0.759
40		0.315	0.503	0.755
50		0.313	0.501	-
65		0.311	0.499	-
80		0.310	0.498	-
100		0.309	0.498	-

GX89	i_n	GXC		
		B5 - B14		
		IEC 80	IEC 90	IEC 100-112
7.5		-	6.898	7.671
10		-	5.875	6.648
15		-	5.144	5.917
20		-	3.398	5.661
25		-	3.256	5.520
30		-	3.215	5.479
40		-	3.151	-
50		-	3.115	-
65		2.024	3.096	-
80		2.014	3.087	-
100		2.008	3.080	-

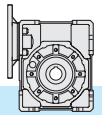

5.12 Tamaño

5.12 Dimensions

5.12 Dimensions

GXC

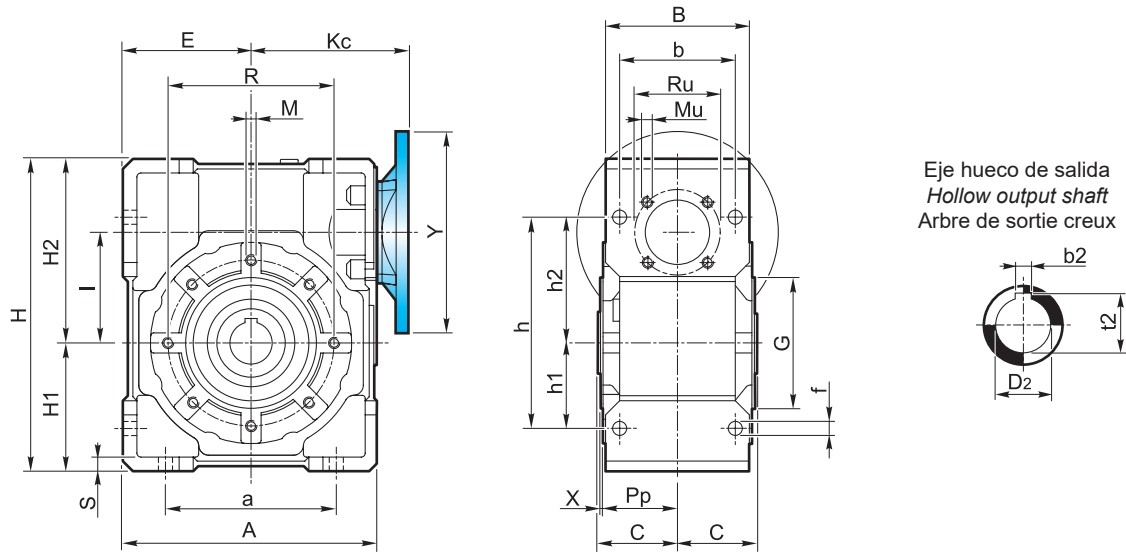

Eje hueco de salida
Hollow output shaft
Arbre de sortie creux

Brida pendular / Side cover for shaft mounting / Bride pendulaire

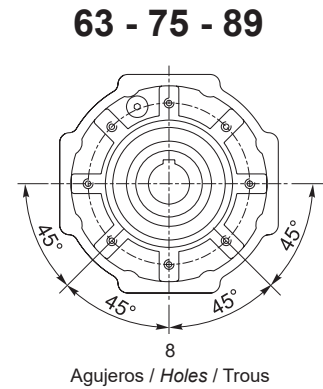
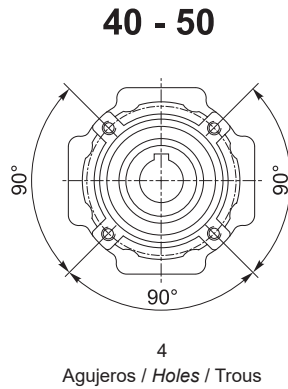
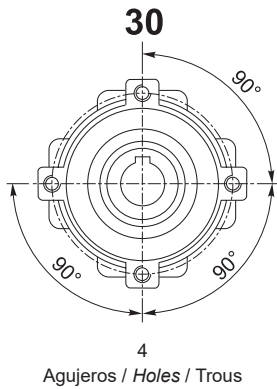

GX	A	a	B	b	b ₂	C	D ₂ H8	E	f	G h8	H	H ₁	H ₂	h	h ₁	h ₂
30	80	54	56	44	5	31.5	14	40	6.5	55	97	40	57	71	27	44
40	105	70	71	60	6	39	18	50	6.5	60	125	50	75	90	35	55
50	125	80	85	70	8	46	25	60	8.5	70	150	60	90	104	40	64
63	147	100	103	85	8	56	25	72	9	80	182	72	110	130	50	80
75	176	120	112	90	8	60	28	86	11	95	219.5	86	133.5	153	60	93
89	203	140	130	100	10	70	35	103	13	110	248.5	103	145.5	172	70	102

GX	I	K _c	L	M	M _u	P _p	R	Ru	S	t ₂	X
30	31.5	57	15	M6x8	M5x7.5	29	65	35.4	5.5	16.3	1.5
40	40	75	20	M6x10	M5x10	36.5	75	42.4	6	20.8	1.5
50	50	82	25	M8x10	M6x10	43.5	85	53.7	7	28.3	1.5
63	63	95	30	M8x14	M6x12	53	95	60.8	8	28.3	2
75	75	112 - 110 ⁽¹⁾	40	M8x14	M8x12	57	115	70.7	10	31.3	2
89	90	122	40	M10x18	M8x14	67	130	70.7	12	38.3	2

(1): Solo para PAM 71B14 / Only for PAM 71B14 / juste pour PAM 71B14

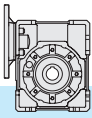

5.12 Tamaño

5.12 Dimensions

5.12 Dimensions

Brida de salida / Output flange / Bride de sortie

Vista de A / View from A / Vue depuis A

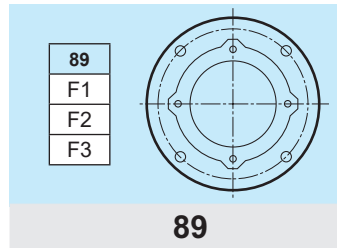
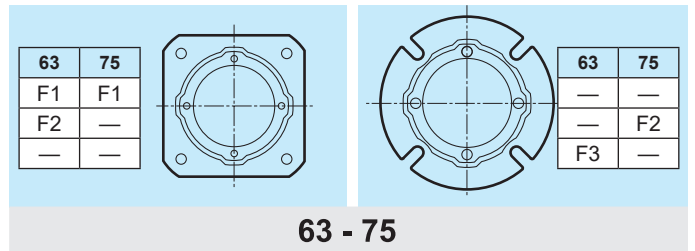
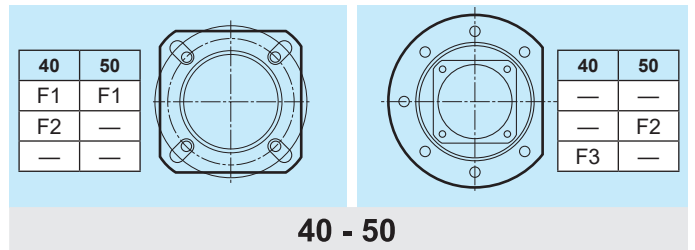
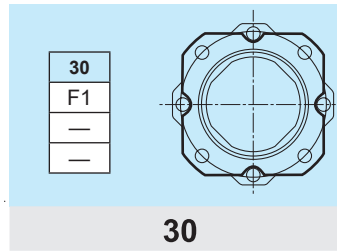
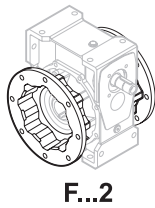
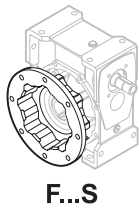
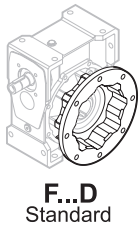
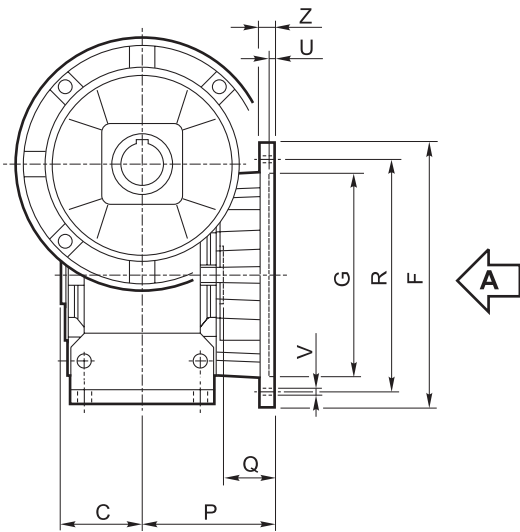

GXC	C	F		G H8	P	Q	R	U	V			Z
30	31.5		66	50	54.5	23	68	4	n° 4		6.5	6
		F1										
		F2										
40	39		85	60	67	28	75-90	4	n° 4		9	8
		F1										
		F2										
50	46		140	95	80	41	115	5		n° 7	9	10
		F1										
		F2										
63	56		94	70	90	44	85-100	5	n° 4		11	10
		F1										
		F2										
75	60		160	110	89	43	130	5		n° 7	11	11
		F1										
		F2										
89	70		142	115	82	26	150	5	n° 4		11	11
		F1										
		F2										
89	70		160	110	112	56	150	5	n° 4		11	11
		F1										
		F2										
89	70		160	110	80.5	24.5	130	5	n° 4		11	12
		F1										
		F2										
89	70		160	130	111	51	165	5	n° 4		13	12
		F1										
		F2										
89	70		200	130	90	30	130	6	n° 4		11	13
		F1										
		F2										
89	70		200	152	111	41	175	5	n° 4		13	12
		F1										
		F2										
89	70		200	152	151	81	175	5	n° 4		13	13
		F1										
		F2										
89	70		200	130	110	40	165	6	n° 4		11	11
		F1										
		F2										

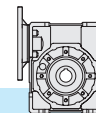

5.12 Tamaño

5.12 Dimensions

5.12 Dimensions

Brida entrada / Input flange / Bride d'entrée

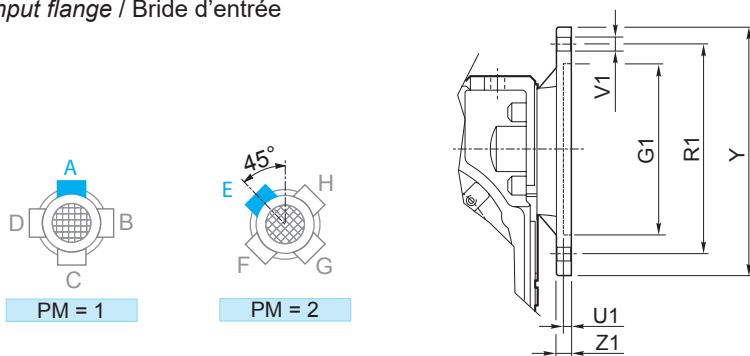

GXC	IEC	G ₁	PM		R ₁	U ₁	V ₁			Y	Z ₁	Diámetro orificio PAM / Holes diameter IEC / Diamètres trous PAM													
			1	2			Ø						5	7.5	10	15	20	25	30	40	50	65	80	100	
30	56 B5	80	•	•	100	4	7	8			8	9	9	9	9	9	9	9	9	9	9	9	9	9	9
	56 B14	50	•	•	65	3.5	6	8		80	8	9	9	9	9	9	9	9	9	9	9	9	9	9	9
	63 B5	95	•	•	115	4	9	8		140	8	11	11	11	11	11	11	11	11	11	11	11	11	11	11
	63 B14	60	•	•	75	4	6	8		90	8	11	11	11	11	11	11	11	11	11	11	11	11	11	11
40	56 B5	80	•	•	100	4	7	8		120	9	/	/	/	/	/	/	/	/	9	9	9	9	9	9
	56 B14	50	•	•	65	3.5	6	8	4	80	8	/	/	/	/	/	/	/	/	9	9	9	9	9	9
	63 B5	95	•	•	115	4	9	8		140	9	11	11	11	11	11	11	11	11	11	11	11	11	11	11
	63 B14	60	•	•	75	3.5	6	8	4	90	8	11	11	11	11	11	11	11	11	11	11	11	11	11	11
	71 B5	110	•	•	130	4.5	9	8		160	10	14	14	14	14	14	14	14	14	/	/	/	/	/	/
	71 B14	70	•	•	85	3.5	7	8		105	8	14	14	14	14	14	14	14	14	/	/	/	/	/	/
50	63 B5	95	•	•	115	4	9	8		140	9	/	/	/	/	/	/	/	11	11	11	11	11	11	11
	63 B14	60	•	•	75	3.5	6	8	4	90	8	/	/	/	/	/	/	/	11	11	11	11	11	11	11
	71 B5	110	•	•	130	4.5	9	8		160	10	14	14	14	14	14	14	14	14	14	14	14	14	14	14
	71 B14	70	•	•	85	3.5	7	8	4	105	8	14	14	14	14	14	14	14	14	14	14	14	14	14	14
	80 B5	130	•	•	165	4.5	11	8		200	10	19	19	19	19	19	19	19	19	/	/	/	/	/	/
	80 B14	80	•	•	100	4	7	8		120	10	19	19	19	19	19	19	19	19	/	/	/	/	/	/
63	71 B5	110	•	•	130	4.5	9	8		160	10	/	/	/	/	/	/	/	14	14	14	14	14	14	14
	71 B14	70	•	•	85	3.5	7	8	4	105	10	/	/	/	/	/	/	/	14	14	14	14	14	14	14
	80 B5	130	•	•	165	4.5	11	8		200	10	19	19	19	19	19	19	19	19	19	19	19	19	19	19
	80 B14	80	•	•	100	4	7	8	4	120	10	19	19	19	19	19	19	19	19	19	19	19	19	19	19
	90 B5	130	•	•	165	4.5	11	8		200	10	24	24	24	24	24	24	24	24	/	/	/	/	/	/
	90 B14	95	•	•	115	4	8.5	8		140	10	24	24	24	24	24	24	24	24	/	/	/	/	/	/
75	71 B5	110	•	•	130	4.5	9	8		160	10	/	/	/	/	/	/	/	14	/	/	14	14	14	14
	71 B14	70	•	•	85	4	7	8	4	105	11	/	/	/	/	/	/	/	14	/	/	14	14	14	14
	80 B5	130	•	•	165	4.5	11	8		200	10	/	/	/	/	/	/	/	19	19	19	19	19	19	19
	80 B14	80	•	•	100	4	7	8	4	120	11	/	/	/	/	/	/	/	19	19	19	19	19	19	19
	90 B5	130	•	•	165	4.5	11	8		200	10	/	24	24	24	24	24	24	24	24	24	24	24	24	24
	90 B14	95	•	•	115	4	9	8	4	140	11	/	24	24	24	24	24	24	24	24	24	24	24	24	24
	100/112 B5	180	•	•	215	5	14	8		250	13	/	28	28	28	28	28	28	28	/	/	/	/	/	/
100/112 B14	110	•	•	130	4.5	9	8		160	11	/	28	28	28	28	28	28	28	/	/	/	/	/	/	
89	80 B5	130	•	•	165	4.5	11	8		200	10	/	/	/	/	/	/	/	/	/	19	19	19	19	19
	80 B14	80	•	•	100	4	7	8	4	120	11	/	/	/	/	/	/	/	/	/	19	19	19	19	19
	90 B5	130	•	•	165	4.5	11	8		200	10	/	24	24	24	24	24	24	24	24	24	24	24	24	24
	90 B14	95	•	•	115	4	9	8	4	140	11	/	24	24	24	24	24	24	24	24	24	24	24	24	24
	100/112 B5	180	•	•	215	5	14	8		250	13	/	28	28	28	28	28	28	28	/	/	/	/	/	/
	100/112 B14	110	•	•	130	4.5	9	8		160	11	/	28	28	28	28	28	28	28	/	/	/	/	/	/

N.B.: El montaje STD de P_M=2 solo cuando no es posible el montaje STD di P_M=1.

N.B.: Es posible también realizar todas las composiciones híbridas obtenibles de las bridas existentes.

N.B.: STD mounting of P_M=2 only if STD mounting of P_M=1 is not possible.

N.B.: it is possible to create hybrid combinations with the existing flanges.

N.B.: Montage STD P_M=2 seulement lorsque le montage STD P_M=1 n'est pas possible.

N.B.: Il est possible de réaliser des compositions hybrides à partir des bridas existantes.

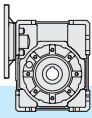

5.13 Entrada suplementaria
(tornillos con doble salida)

5.13 Additional input
(double extended shaft)

5.13 Entrée supplémentaire
(double vis)

S.e.A.

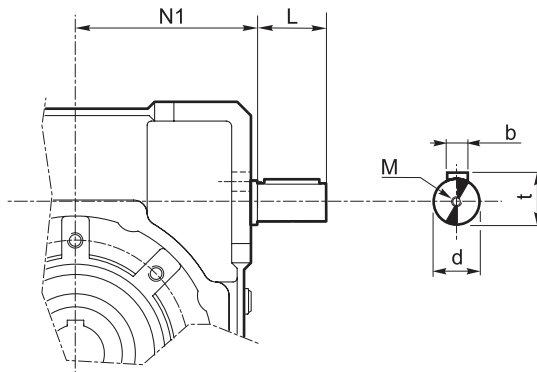

GX	d j6	L	M	N1	b	t
30	9	15	M4x10	42.5	3	10.2
40	11	20	M4x12	52.5	4	12.5
50	14	25	M5x13	62.5	5	16
63	19	30	M8x20	74.5	6	21.5
75	24	40	M8x20	91	8	27
89	24	40	M8x20	108	8	27

5.14 Accesorios
(Brazo de reacción)

5.14 Accessories
(Torque arm)

5.14 Accessoires
(Bras de réaction)

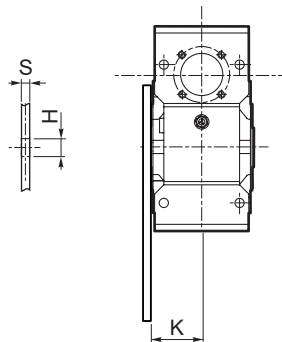
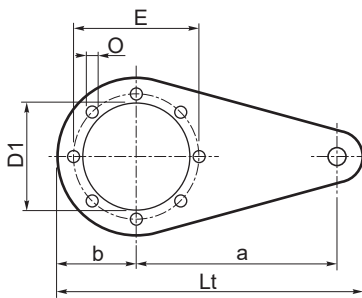

GX	a	b	D ₁	E	H	K	L _t	O	S1	S2
30	85	37.5	55	65	8	24	141.5	7	14	4
40	100	45	60	75	10	31.5	167	7	14	4
50	100	50	70	85	10	39	172	9	14	5
63	150	55	80	95	10	49	227	9	14	6
75	200	70	95	115	20	47.5	302	9	25	6
89	200	80	110	130	20	57.5	312	11	25	6

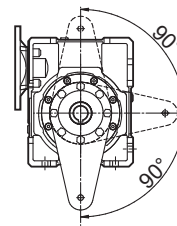

30 - 40 - 50

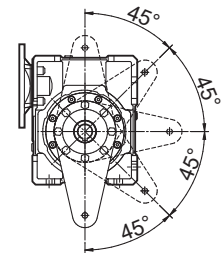

63 - 75 - 89

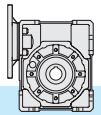

5.15 Lista de recambios

5.15 Spare parts list

5.15 Liste des pièces détachées

Cuando se ordene un recambio, especificar siempre el número particular de cada pieza referenciado en el despiece (ver gráfico de despiece) fecha (1), n° de código (2) y n° variable (3).
(Ver placa de características).

When ordering please specify the spare part number (see exploded view) as well as the date (1), the article number (2) and the variant number (3) (see plate).

Lors de la commande de pièces détachées, toujours rappeler le n° de la pièce (voir plan éclaté), la date (1), le n° de code (2) et le n° de la variante (3).
(Voir plaquette signalétique).

CODIGO: Lista de componentes
CODE: Base list
CODE: Liste du matériel

TIPO: descripción
TYPE: description
TYPE: description

RAP: relación de reducción
RATIO: reduction ratio
RAP: rapport de réduction

VARIANTE:
código alfanumérico
MODEL:
alphanumeric code
VARIANTE:
code alpha numérique

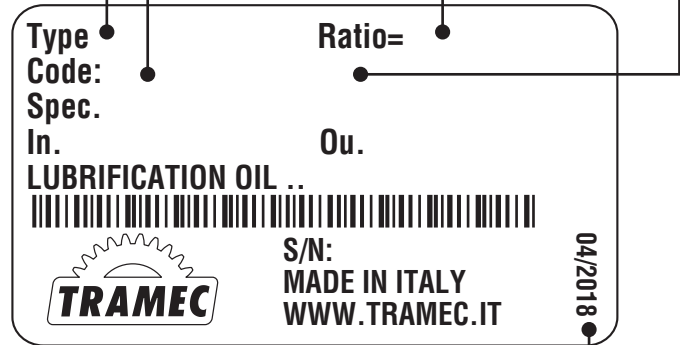

FECHA: mes/año
DATE: month/year
DATE: mois/année

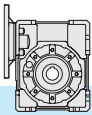

GXC

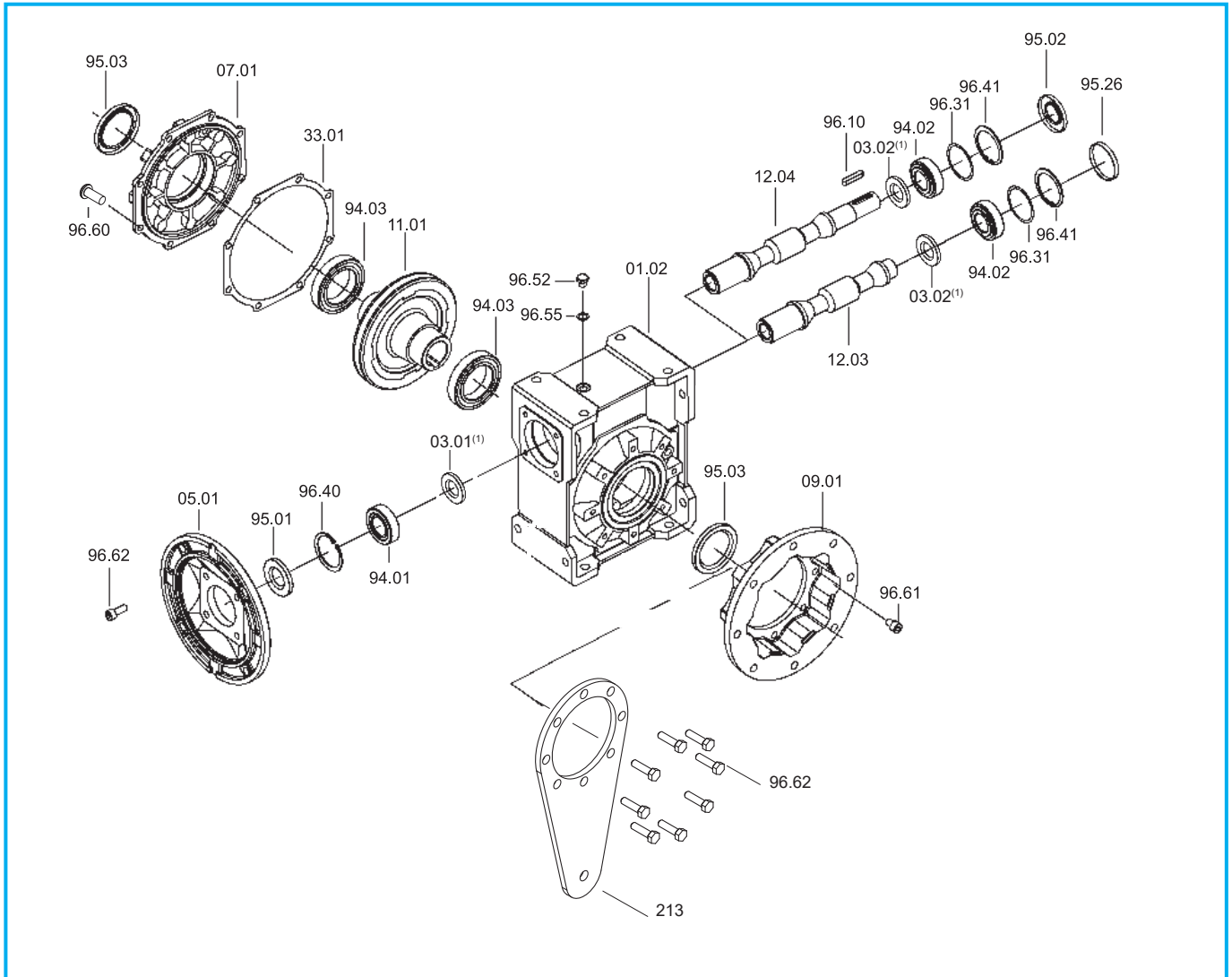

GX	IEC	Cojinetes / Bearings / Roulements			Retenes / Oilseals / Bagues d'étanchéité			Casquete / Closed oil seal / Capot
		94.01	94.02	94.03	95.01	95.02	95.03	95.26
30	56	61804 (20x32x7)	6000 10x26x8	6005 25x47x12	20/32/5	10/26/7	25/40/7	ø 26x7
	63	61804 (20x32x7)			20/32/5			
40	56	6303 (17x47x14)	6201 12x32x10	6006 30x55x13	17/47/7	12/32/7	30/47/7	ø 32x7
	63	6204 (20x47x14)			20/47/7			
	71	6005 (25x47x12)			25/47/7			
50	63	6204 (20x47x14)	6203 17x40x12	6008 40x68x15	20/47/7	17/40/7	40/62/8	ø 40x7
	71	6005 (25x47x12)			25/47/7			
	80	6006 (30x55x13)			30/55/7			
63	71	6305 (25x62x17)	6204 C3 20x47x14	6008 40x68x15	25/62/7	20/47/7	40/62/8	ø 47x7
	80	6206 (30x62x16)			30/62/7			
	90	6007 (35x62x14)			35/62/7			
75	71	6206 (30x62x16)	6205 C3 25x52x15	6010 50x80x16	30/62/7	25/52/7	50/72/8	ø 52x7
	80	6206 (30x62x16)			30/62/7			
	90	6007 (35x62x14)			35/62/7			
	100/112	6008 (40x68x15)			40/68/10			
89	80	6206 (30x62x16)	6205 C3 25x52x15	6010 50x80x16	30/62/7	25/52/7	50/72/8	ø 52x7
	90	6007 (35x62x14)			35/62/7			
	100/112	6008 (40x68x15)			40/68/10			

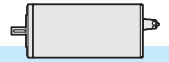

6.0	MOTORES MHA PREMIUM	MHA PREMIUM MOTORS	MOTEURS MHA PREMIUM	
6.1	Características	<i>Characteristics</i>	Caractéristiques	98
6.2	Datos técnicos	<i>Technical data</i>	Données techniques	99
6.3	Tamaño	<i>Dimensions</i>	Dimensions	99

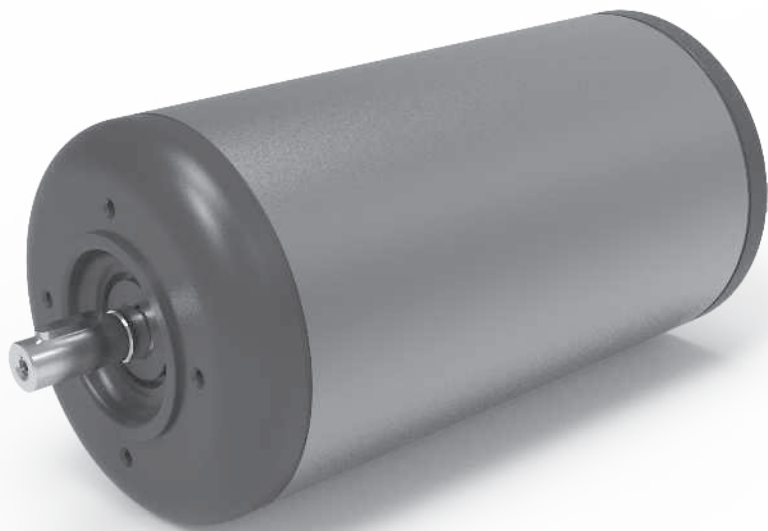

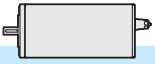

6.1 Características

La nueva gama GHA incluye los motores MHA PREMIUM (clase energética IE4), que al igual que los reductores de la serie GHA PREMIUM, llevan una carcasa de aleación de aluminio sometida a un tratamiento G.H.A. potenciado.

El cuerpo de estos motores, además, lleva un perfil especial externo liso, diseñado específicamente para que esté perfectamente limpio.

Complemento ideal de los reductores de la serie GHA PREMIUM, los motores MHA PREMIUM presentan las siguientes características especiales, que se suman a las características NANOTECHNOLÓGICAS ya descritas para los reductores GHA PREMIUM (excelentes propiedades antibacterianas y contra la corrosión):

- Disipación térmica superior al 35 % respecto a la versión sin tratamiento G.H.A.
- Mayor eficiencia del motor, gracias a la mayor disipación térmica
- Capacidad de soportar altos voltajes, gracias a las características amagnéticas

Gracias a sus características especiales, los motores MHA PREMIUM son la solución ideal para las aplicaciones en la industria ALIMENTARIA (no en contacto con los alimentos), FARMACÉUTICA y MARÍTIMA.

6.1 Characteristics

Similarly to the GHA PREMIUM series reducers, the new GHA range includes MHA PREMIUM motors (energy class IE4) equipped with an aluminium alloy casing subjected to enhanced G.H.A. treatment.

The body of these motors also has a special smooth external profile specially designed to allow for maximum cleanliness.

The ideal complement to GHA PREMIUM reducers is the MHA PREMIUM motor that has the following special features, which are added to the NANOTECHNOLOGICAL characteristics already described for the GHA PREMIUM reducers (excellent bactericidal and anticorrosive properties):

- Thermal dissipation 35% greater than the version without G.H.A. treatment*
- Greater motor efficiency thanks to the higher heat dissipation*
- Ability to withstand high voltages, thanks to the non-magnetic characteristics*

Thanks to their special characteristics, MHA PREMIUM motors are the ideal solution for applications in the FOOD (not in contact with food), PHARMACEUTICAL and MARINE SECTORS.

6.1 Caractéristiques

La nouvelle gamme GHA comprend les moteurs MHA PREMIUM (classe énergétique IE4) dotés, tout comme les réducteurs de la série GHA PREMIUM, d'une carcasse en alliage d'aluminium soumise au traitement G.H.A. renforcé.

Le corps de ces moteurs présente par ailleurs un profil extérieur lisse spécial, spécialement conçu pour permettre la plus grande propreté.

Complément idéal des réducteurs GHA PREMIUM, les moteurs MHA PREMIUM possèdent les caractéristiques spéciales suivantes, qui viennent s'ajouter aux caractéristiques NANOTECHNOLOGIES déjà décrites pour les réducteurs GHA PREMIUM (excellentes propriétés bactéricides et anticorrosives) :

- Dissipation thermique supérieure de 35 % par rapport à la version sans traitement G.H.A.
- Plus grande efficacité du moteur due à la plus grande dissipation thermique
- Capacité de supporter de hautes tensions, grâce à leurs caractéristiques amagnétiques.

Grâce à leurs caractéristiques spéciales, les moteurs MHA PREMIUM constituent la solution idéale pour des applications dans le secteur ALIMENTAIRE (pas en contact avec les aliments), PHARMACEUTIQUE et MARIN.

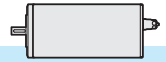

6.2 Datos técnicos

6.2 Technical data

6.2 Données techniques

IE4	4 POSTE / 4 POLES / 4 POTEAU								
	P _n (kW)	n ₁ (rpm)	η % 100% P _n	cos φ	I _n (A)	T _n (Nm)	T _{sp} T _n	I _{sp} I _n	Kg
MHA 63 AS MHA 63 AM	0.13	1400	70.9	0.73	0.38	0.88	3.6	6.5	8.8
MHA 63 BS MHA 63 BM	0.18	1420	74.5	0.73	0.48	1.25	3.78	6.4	9.5
MHA 71 AS MHA 71 AM	0.25	1440	77.9	0.81	0.56	1.7	3.7	7.2	13
MHA 71 BS MHA 71 BM	0.37	1440	81.1	0.79	0.83	2.44	4.63	8.34	14.5
MHA 80 AS MHA 80 AM	0.5	1450	83.2	0.71	1.24	3.3	5.25	8.43	18
MHA 80 BS MHA 80 BM	0.75	1450	85.7	0.72	1.77	4.95	5.8	8.52	19
MHA 90 AS	1.1	1440	87.2	0.79	2.28	7.3	4.2	8.9	25
MHA 90 BS	1.5	1460	88.2	0.77	3.16	9.85	4.9	10.0	32

ATENCIÓN: Los datos técnicos que figuran en las tablas se refieren a una tensión de alimentación de 230/400 V, 50 Hz.

WARNING: Technical data are referred to voltage 230/400V, 50Hz.

ATTENTION: Les données techniques reportées dans les tableaux se réfèrent à une tension d'alimentation de 230/400 V, 50 Hz.

6.3 Tamaño

6.3 Dimensions

6.3 Dimensions

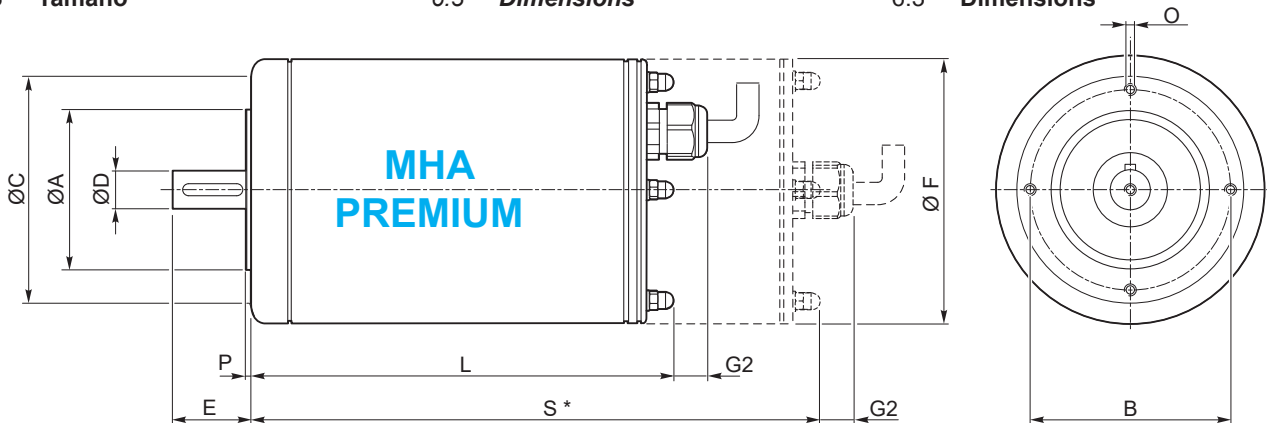

*S: cota válida solo para las versiones bajo pedido (freno, codificador, etc.).

*S: value valid only for the versions on request (brake, encoder, ecc.).

*S: cote valable uniquement pour les versions sur demande (frein, codeur, etc.).

MHA	IEC B14										
	A j6	B	C	IEC B14	D j6	E	F	G2	L	O	P
63 AS 63 BS	60	75	90	63	11	23	118	16 ⁽¹⁾	235	M5	2
63 AM 63 BM	70	85	105	71	14	30	118		235	M6	2.5
71 AS 71 BS	70	85	105	71	14	30	134		246	M6	2.5
71 AM 71 BM	80	100	120	80	19	40	134		246	M6	3
80 AS 80 BS	80	100	120	80	19	40	150		271	M6	3
80 AM 80 BM	95	115	140	90	24	50	150		271	M8	3
90 AS 90 BS	95	115	140	90	24	50	190		339	M8	3

(1): con prensaestopas estándar

(1): with standard cable gland

(1): avec presse-étoupe ordinaire

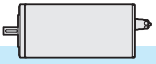

GHA - CLASSIC

La nueva gama GHA incluye también los motores GHA CLASSIC (clase energética IE1 e IE3) que, al igual que los reductores de la serie GHA CLASSIC, llevan carcasa de aleación de aluminio sometida a tratamiento G.H.A. estándar.

Las carcasas son de tipo clásico con aletas, disponibles en las versiones B5 y B14.

Estos motores, complemento ideal de los reductores de las series GHA CLASSIC y GHA MODULAR, presentan las siguientes características especiales, que se suman a las características NANOTECHNOLÓGICAS ya descritas para los reductores GHA CLASSIC y GHA MODULAR (excelentes propiedades antibacterianas y resistencia estándar a la corrosión):

- Disipación térmica superior al 35 % respecto a la versión sin tratamiento G.H.A.
- Mayor eficiencia del motor, gracias a la mayor disipación térmica
- Capacidad de soportar altos voltajes, gracias a las características amagnéticas

Gracias a sus características especiales, los motores GHA CLASSIC son especialmente idóneos para las aplicaciones en la industria ALIMENTARIA (no en contacto con los alimentos) y farmacéutica.

GHA - CLASSIC

The new GHA range also includes GHA CLASSIC motors (energy class IE1 and IE3) which, like the GHA CLASSIC series reducers, are fitted with an aluminium alloy casing subjected to standard G.H.A. treatment.

The casings are of the classic finned type, available in versions B5 and B14.

These motors are the ideal complement to GHA CLASSIC and GHA MODULAR series reducers and feature the following special characteristics on top of the NANOTECHNOLOGICAL characteristics already described for the GHA CLASSIC and GHA MODULAR reducers (excellent antibacterial properties and standard corrosion resistance):

- Thermal dissipation 35% greater than the version without G.H.A. treatment
- Greater motor efficiency thanks to the higher heat dissipation
- Ability to withstand high voltages, thanks to the non-magnetic characteristics

Thanks to their special characteristics, GHA CLASSIC motors are particularly suitable for applications in the FOOD (not in contact with food), PHARMACEUTICAL sectors.

GHA - CLASSIC

La nouvelle gamme GHA comprend aussi les moteurs GHA CLASSIC (classe énergétique IE1 et IE3) qui, tout comme les réducteurs de la série GHA CLASSIC, sont dotés d'une carcasse en alliage d'aluminium soumise au traitement G.H.A. standard.

Les carcasses sont du type classique à ailettes, disponibles dans les versions B5 et B14.

Ces moteurs, complément idéal des réducteurs des séries GHA CLASSIC et GHA MODULAR, possèdent les caractéristiques spéciales suivantes qui viennent s'ajouter aux caractéristiques NANOTECHNOLOGIES déjà décrites pour les réducteurs GHA CLASSIC et GHA MODULAR (excellentes propriétés bactéricides, résistance standard à la corrosion) :

- Dissipation thermique supérieure de 35 % par rapport à la version sans traitement G.H.A.
- Plus grande efficacité du moteur due à la plus grande dissipation thermique
- Capacité de supporter de hautes tensions, grâce à leurs caractéristiques amagnétiques.

Grâce à leurs caractéristiques spéciales, les moteurs GHA CLASSIC conviennent tout particulièrement aux applications dans le secteur ALIMENTAIRE (pas en contact avec les aliments) et PHARMACEUTIQUE.

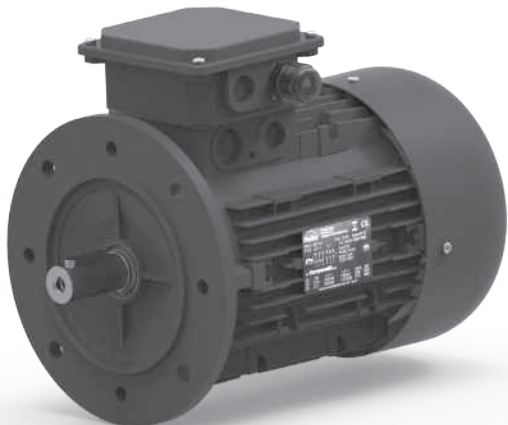

B5

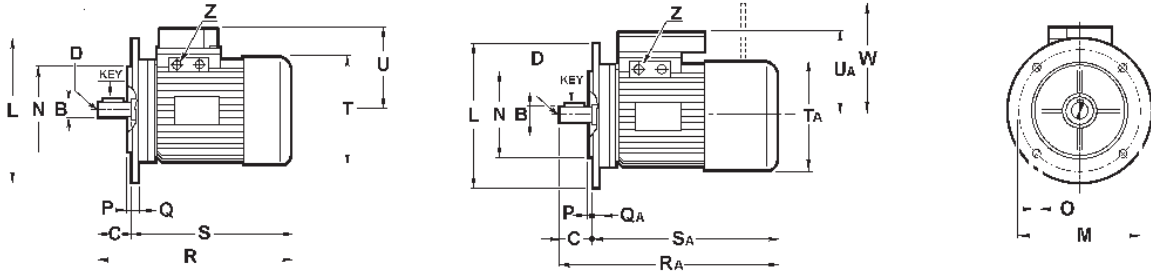

Motores eléctricos ⁽¹⁾
Electric motors
Moteurs électriques

Motori elettrici autofrenanti ⁽²⁾
Electric brake motors
Moteurs électriques auto-freinants

	4 poles			B	C	D	L	M	N	O	P	Q	QA	R	RA	S	SA	T	TA	U	UA	W	Z	KEY	
		kW	kg. (1)																						kg. (2)
56	A	0.06	2.5	4	9	20	M4	120	100	80	7	3	8	8	188	220	167	200	110	110	110	108	90	PG11	3x3x15
	B	0.09	2.6	5																				PG11	3x3x15
	C	0.11	3.2	5																				PG11	3x3x15
63	A	0.13	3.7	5	11	23	M4	140	115	95	9	3	9	9	208	257	193	234	123	123	115	110	98	PG11	4x4x15
	B	0.18	4.3	7																				PG11	
	C	0.22	4.3	7																				PG11	
71	A	0.25	5.8	8	14	30	M5	160	130	110	9	3.5	9	9	245	297	215	267	138	138	124	121	98	PG11	5x5x20
	B	0.37	6.2	8																				PG11	
	C	0.55	7.4	9																				PG11	
80	A	0.55	8.5	11	19	40	M6	200	165	130	11	3.5	10	10	278	336	235	296	156	156	141	138	111	PG16	6x6x30
	B	0.75	9.8	13																				PG16	
	C	0.9	10.5	13.5																				PG16	
90	S	1.1	12	17	24	50	M8	200	165	130	11	3.5	10	10	305	369	250	319	176	176	146	149	129	PG16	8x7x35
	L	1.5	13.5	18											330	394	275	344						PG16	
	LB	1.8	15.5	20											PG16										
100	A	2.2	19	25.5	28	60	M10	250	215	180	14	4	14	14	369	434	305	374	194	194	157	160	139	PG16	8x7x45
	B	3	21	28																				PG16	
	BL	4	23	30																				PG16	
112	A	4	29	38	28	60	M10	250	215	180	14	4	14	14	388	467	325	407	220	220	170	172	161	PG16	8x7x45
	BL	5.5	35	44																				PG16	

Las dimensiones de los motores eléctricos son meramente indicativas.

The dimensions of the electric motors are approximate values.

La taille des moteurs est purement indicative.

B14

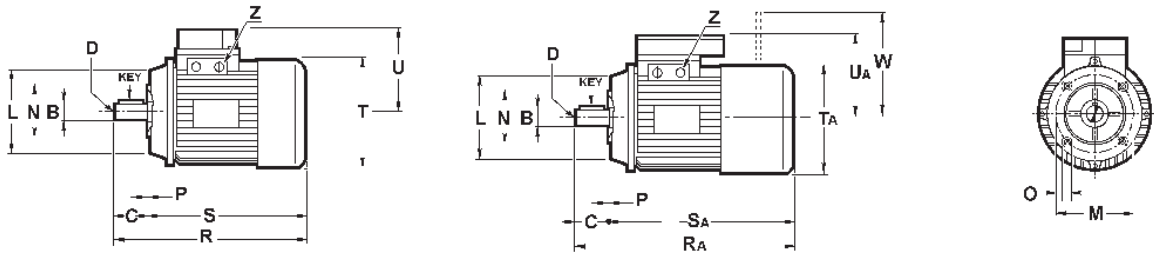

Motores eléctricos ⁽¹⁾
Electric motors
Moteurs électriques

Motori elettrici autofrenanti ⁽²⁾
Electric brake motors
Moteurs électriques auto-freinants

	4 poles	kW	kg. (1)	kg. (2)	B	C	D	L	M	N	O	P	R	RA	S	SA	T	TA	U	UA	W	Z	KEY
56	A	0.06	2.5	4	9	20	M4	80	65	50	M5	2.5	188	220	167	200	110	110	110	108	90	PG11	3x3x15
	B	0.09	2.6	5																		PG11	3x3x15
	C	0.11	3.2	5																		PG11	3x3x15
63	A	0.13	3.7	5	11	23	M4	90	75	60	M5	2.5	208	257	193	234	123	123	115	110	98	PG11	4x4x15
	B	0.18	4.3	7																		PG11	
	C	0.22	4.3	7																		PG11	
71	A	0.25	5.8	8	14	30	M5	105	85	70	M6	2.5	245	297	215	267	138	138	124	121	98	PG11	5x5x20
	B	0.37	6.2	8																		PG11	
	C	0.55	7.4	9																		PG11	
80	A	0.55	8.5	11	19	40	M6	120	100	80	M6	3	278	336	235	296	156	156	141	138	111	PG16	6x6x30
	B	0.75	9.8	13																		PG16	
	C	0.9	10.5	13.5																		PG16	
90	S	1.1	12	17	24	50	M8	140	115	95	M8	3	305	369	250	319	176	176	146	149	129	PG16	8x7x35
	L	1.5	13.5	18									330	394	275	344							
	LB	1.8	15.5	20																			
100	A	2.2	19	25.5	28	60	M10	160	130	110	M8	3.5	369	434	305	374	194	194	157	160	139	PG16	8x7x45
	B	3	21	28																			
	BL	4	23	30																			
112	A	4	29	38	28	60	M10	160	130	110	M8	3.5	388	467	325	407	220	220	170	172	161	PG16	8x7x45
	BL	5.5	35	44																		PG16	8x7x45

Le dimensioni dei motori elettrici sono puramente indicative.

The dimensions of the electric motors are approximate values.

La taille des moteurs est purement indicative.

8.0

CONDIZIONI GENERALI DI VENDITA

TERMS AND CONDITIONS OF SALE

8.1	Scopo	<i>Purpose</i>	106
8.1.1	Modifiche alle condizioni generali di vendita	<i>Modification of the conditions of sale</i>	106
8.2	Definizioni generali	<i>General definitions</i>	106
8.3	Riferimenti	<i>References</i>	106
8.4	Offerte e ordinazioni	<i>Offers and orders</i>	106
8.4.1	Offerte	<i>Offers</i>	106
8.4.2	Ordini	<i>Orders</i>	107
8.4.3	Conferma d'ordine	<i>Order confirmation</i>	107
8.5	Prezzo dei prodotti	<i>Price of the products</i>	107
8.6	Spedizione e trasporto	<i>Shipping and transport</i>	108
8.7	Termini di consegna	<i>Terms of delivery</i>	108
8.8	Pagamenti	<i>Payments</i>	108
8.8.1	Reclami e/o contestazioni	<i>Claims and / or disputes</i>	108
8.8.2	Non conformità	<i>Non-compliance</i>	109
8.8.3	Restituzione del materiale	<i>Return of material</i>	109
8.8.4	Garanzia dei prodotti	<i>Product warranty</i>	109
8.9	Marchi e diritti di proprietà intellettuale	<i>Trademarks and intellectual property rights</i>	109
8.10	Controversie e risoluzione contrattuale	<i>Disputes and contract termination</i>	110
8.10.1	Clausola risolutiva art. 1455 C.C.	<i>Termination art. 1455 C.C. (Italian Civil Code)</i>	110
8.10.2	Clausola risolutiva art. 1461 C.C.	<i>Termination art. 1461 C.C. (Italian Civil Code)</i>	110

8.1 Scopo

Le presenti "Condizioni Generali di Vendita" (di seguito denominate "Condizioni di Vendita"), si applicano e regolano tutte le forniture di prodotti con marchio "TRAMEC" e/o commercializzate dalla stessa, e annullano qualsiasi clausola o termine pattuito dal Cliente, sia nella singola vendita che in documentazioni di provenienza dello stesso, che non sia stata accettata da un preventivo consenso scritto da parte di "TRAMEC Srl".

8.1.1 Modifiche alle condizioni di vendita

"TRAMEC Srl" si riserva il diritto di modificare, aggiungere, cancellare qualsiasi punto delle presenti Condizioni di Vendita, che si riterranno applicate a tutti gli ordini successivi alla data di notifica al Cliente delle nuove Condizioni di Vendita.

8.2 Definizioni generali

Per una maggiore chiarezza nella lettura delle presenti Condizioni di Vendita, si definiscono i seguenti termini:

- "TRAMEC" : TRAMEC Srl, Via Bizzarri,6 – 70012 Caldera di Reno (BO) - ITALY
- "Prodotti": Tutti i beni prodotti, assemblati, commercializzati e/o venduti da TRAMEC Srl
- "Cliente" : Tutte le società legalmente costituite e/o entità giuridiche che acquistano beni, prodotti o servizi da TRAMEC Srl
- "Ordine" : Ogni proposta di acquisto di beni, prodotti o servizi inoltrata da un cliente a TRAMEC Srl e confermata per accettazione con "Conferma d'ordine" dalla stessa.
- "Marchi" : Tutti i marchi di proprietà di TRAMEC Srl di cui è proprietaria e/o licenziataria
- "Brevetti e Proprietà Intellettuale" : Qualsiasi diritto legato alla protezione del proprio Know-How, coperto da brevetti italiani e internazionali, per invenzioni, marchi, modelli, disegni e prodotti di cui TRAMEC Srl ne detiene ed è proprietaria dei diritti, siano essi registrati ,che in fase di registrazione compresi qualsiasi altra forma prevista dalla leggi internazionali.

8.3 Riferimenti

Il presente documento è parte integrante del "LISTINO PREZZI TRAMEC", di cui copia è pubblicata sul sito aziendale www.tramec.it

8.4 Offerte e ordinazioni

8.4.1 Offerte

Su richiesta del Cliente, TRAMEC direttamente o attraverso la propria rete vendita, formulerà una proposta di acquisto per i propri prodotti indicati dal Cliente, formalizzandola per iscritto. L'offerta di vendita/proposta di acquisto non è da ritenersi impegnativa da parte del Cliente, e avrà validità 30(trenta) giorni. Allo scadere di tale termine, TRAMEC si riterrà svincolata da impegni e su richiesta del cliente riformulerà una nuova offerta/proposta. Data la natura riservata del contenuto dell'offerta/proposta ricevuta il Cliente, si impegna a non divulgarne il contenuto.

8.1 Purpose

The present "General Conditions of Sale" (hereinafter referred to as "Conditions of Sale"), shall apply and shall govern all supplies of "TRAMEC" products with "TRAMEC" label and / or directly commercialized by "TRAMEC" , and cancel any clause or term agreed upon by the Customer which have not been accepted by prior consent in writing by "TRAMEC Srl".

8.1.1 Modification of the conditions of sale

"TRAMEC SRL" reserves the right to modify, add, delete any part of these "Conditions of Sale", which will be deemed to apply to all orders received after the date of Customer's notification.

8.2 General definitions

For a better understanding of these Conditions of Sale, we define the following terms:

- "TRAMEC" : TRAMEC Srl, Via Bizzarri,6 – 70012 Caldera di Reno (BO) - ITALY
- "Products": *All goods manufactured, assembled, commercialized and / or sold by TRAMEC Srl.*
- "Customers" : *All companies legally established and / or legal entities buying goods, products or services from TRAMEC SRL*
- "Orders" : *Each offer to purchase goods, products or services sent by the Customer to TRAMEC Srl and confirmed for acceptance with an "order confirmation" directly from TRAMEC Srl*
- "Trademarks" : *All trademarks owned or of which TRAMEC Srl is licensee.*
- "Patents and Intellectual Property" : *all rights related to the protection of their own Know - How, covered with Italian and international patents for inventions, trademarks, models, designs and products for which TRAMEC SRL holds and owns the rights, whether registered or under registration, including any other form prescribed by the International laws.*

8.3 References

This document is an integral part of the "PRICE LIST of TRAMEC", a copy of which is posted on the company website www.tramec.it

8.4 Offers and orders

8.4.1 Offers

On customer request, TRAMEC directly or through its own sales network, will submit a written proposal for the products required by the Customer. The offer shall not be binding for the Customer and will have a 30 (thirty) days validity. After this period the offer is void and upon Customer request TRAMEC will submit a new proposal. TRAMEC written offers are intended for the receipt and viewing of the Customer, and disclosure of the offer with competitors could render the offer null and void.

8.4.2 Ordini

Tutti gli ordini di acquisto dei prodotti TRAMEC, devono essere formalizzati per iscritto dal Cliente su propria carta intestata ed inviati tramite mail, fax o lettera direttamente ai riferimenti indicati nell'offerta/proposta ricevuta, avendo cura di aver indicato:

- Riferimento a n. offerta,
- codice prodotto,
- descrizione prodotto,
- quantità richiesta,
- prezzi e termini di consegna.

TRAMEC ha previsto la possibilità di accettare anche ordini a carattere di "URGENZA" **previ accordi telefonici con il commerciale TRAMEC di riferimento**, che devono essere formalizzati per iscritto dal Cliente, e che prevedono una consegna entro 5 (cinque) oppure 6-9 (da sei a nove) gg lavorativi dalla data di accettazione dell'ordine stesso. A tali ordini verrà applicato una maggiorazione del **15% (quindicipercento)** e del **7% (settepercento)** rispettivamente, calcolata sul totale lordo EX WORKS dell'ordine, in aggiunta agli importi netti totali.

ATTENZIONE!!

Tutti gli ordini a carattere d'urgenza, una volta accettati e confermati da TRAMEC, non saranno più modificabili né cancellabili.

8.4.3 Conferma d'ordine

La vendita si riterrà conclusa con l'invio della Conferma d'Ordine che TRAMEC inoltrerà al Cliente. Tale Conferma d'Ordine sarà inoltrata al cliente tramite mail o su richiesta tramite fax direttamente ai riferimenti indicati dal Cliente. La Conferma d'Ordine sarà conforme, all'ordine di acquisto del Cliente ricevuto da TRAMEC, sia nei termini che nelle condizioni indicate e concordate. Trascorsi 2 (due) giorni lavorativi dall'invio della Conferma d'Ordine, TRAMEC riterrà confermato l'ordine da parte del Cliente ed ogni inesattezza eventualmente contenuta e non contestata in forma scritta da parte del Cliente e confermata sempre in forma scritta da TRAMEC (con nuova Conferma d'Ordine revisionata), evidenziata alla consegna dei prodotti al Cliente non sarà più contestabile o annullabile.

8.5 Prezzo dei prodotti

Tutti i prezzi dei prodotti indicati negli ordini di vendita, e nelle relative offerte, fanno riferimento al listino prezzi TRAMEC, in vigore al momento del loro inoltro al Cliente. Qualora non fosse presente il prodotto in ordine nel listino prezzi TRAMEC, avrà valore quanto concordato e confermato per iscritto nell'ordine stesso.

Eccetto quanto concordato per iscritto tra le parti, i prezzi indicati nell'ordine di vendita TRAMEC sono calcolati franco fabbrica,

al netto dell'IVA e degli sconti. Tali prezzi inoltre non includono eventuali costi di imballaggio, spedizione e trasporto dai locali di TRAMEC ai locali del cliente, che saranno sostenuti separatamente dal Cliente.

TRAMEC manterrà la proprietà dei Prodotti venduti al Cliente fino alla completa corresponsione del prezzo degli stessi. La presente clausola di riserva di proprietà, obbliga il Cliente a compiere tutti gli adempimenti previsti per legge, ove previsto, per rendere valida ed eseguibile nei confronti di tutti i terzi tale vincolo.

TRAMEC si riserva il diritto di modificare unilateralmente e senza preavviso, con effetto immediato i prezzi riportati nel proprio listino, nei casi in cui l'adeguamento sia dovuto a cambiamenti impreveduti di condizioni di mercato delle materie prime o dei tassi di cambio. Ogni modifica verrà comunque comunicata al Cliente ed applicata al successivo ordine ricevuto.

8.4.2 Orders

All purchase orders of TRAMEC products must be formalized in writing by the customer, on his own letterhead and sent via mail, fax or letter directly to the references mentioned in the offer, making sure to add :

- Offer reference number ,
- Product Code,
- Product Description,
- Required Quantity,
- Prices and Terms of Delivery.

An "URGENT" production option may be agreed case by case with the sales department of TRAMEC. To accept the urgent production option , Customer must state in writing, requesting URGENT option, and consider standard shipment of urgent orders to be either 5 (five) or 6-9 (from six to nine) working days from the date of TRAMEC's acceptance of order, depending on availability at order time. Such urgent orders will be charged an additional 15% (fifteen percent) or 7% (seven percent) respectively, calculated on the total EX WORKS value of the order.

ATTENTION!!!!

Urgent orders, once acknowledged by TRAMEC, are non-cancelable and may not be modified.

8.4.3 Order confirmation

TRAMEC will acknowledge the Customers Order via e mail or on request by fax to the address specified by the Customer. All Orders to be performed are subject to the Terms and Conditions Agreed to between the parties.

The Customer will have two (2) days to review the acknowledgment for errors or inaccuracies to notify TRAMEC for correction, after these two (2) days the Order will be considered acknowledged by the Customer and can no longer be contested or canceled.

8.5 Price of the products

All prices listed on the sales orders, and on offers, refer to the Price List of "TRAMEC" valid at time of their transmission to the Customer.

If the product is not mentioned on the Price List of "TRAMEC", its value will be the one agreed to between the parties in writing.

Unless differently agreed, the prices indicated on the sales order of TRAMEC will be calculated on ex-works basis, VAT and Discounts excluded.

These prices do not include any costs for packaging, shipping and transport from TRAMEC warehouse to the Customer premises, which will be paid separately by the Customer.

TRAMEC will retain the ownership of the Products sold to the customer until their complete payment. Because of this saving clause of ownership, the Customer is due to carry out all formalities required by law, and if necessary, to make such a constraint valid and enforceable against all third.

TRAMEC reserves the right to modify the prices of the price list, unilaterally and without notice, with immediate effect , if the adjustment is due to unexpected changes in market conditions, in raw materials or in exchange rates. Each modification will however be noted and indicated on the Order Acknowledgement and will apply to the next order.

8.6 Spedizione e trasporto

La spedizione viene effettuata tramite vettori nazionali ed internazionali, indicati dal Cliente o in mancanza di indicazioni scelti in autonomia da TRAMEC. La scelta del vettore viene effettuata sulla base di valutazione di convenienza e di garanzia del trasporto che il vettore stesso assicura/certifica. Tutto il materiale viaggia a spese e rischio del Cliente stesso, e si intende accettato dal Cliente all'atto di inizio del trasporto da parte del vettore. Eventuali danni occorsi al materiale durante il trasporto, non sono coperti da garanzia TRAMEC. Come indicato al punto 8.5 PREZZO DEI PRODOTTI, la merce viaggia sempre FRANCO FABBRICA.

8.7 Termini di consegna

I termini di consegna indicati nella Conferma d'Ordine, hanno carattere puramente indicativo e sono da ritenersi fissati salvi imprevisti ascrivibili a circostanze di forza maggiore e che siano fuori dal proprio controllo. A titolo esemplificativo e senza pretesa di esaustività si elenca quanto segue:

- a) Ritardi da parte del cliente a fornire dati tecnici o amministrativi necessari alla spedizione dei prodotti
- b) Difficoltà da parte di TRAMEC nell'acquisizione di materie prime necessarie alla produzione dei prodotti
- c) Scioperi parziali o totali, calamità naturali, difficoltà nel trasporto dei materiali, etc. e tutte le altre cause di forza maggiore
- d) Ritardi dovuti a terzi o allo spedizioniere

Il verificarsi di alcuni degli eventi elencati o di altra natura non elencati, non darà diritto al Cliente di esigere indennizzi di sorta o richiesta di risarcimento danni.

8.8 Pagamenti

TRAMEC a propria discrezione emetterà fattura, salvo accordi scritti tra le parti, all'atto della spedizione dei prodotti o in anticipo all'atto dell'accettazione dell'ordine del Cliente. Tutti i pagamenti sono previsti in EURO, eccetto per accordi commerciali che prevedano altra valuta. I pagamenti devono essere effettuati entro i termini stabiliti indicati nella Conferma d'Ordine, anche in presenza di reclami o contestazioni.

Ogni ritardo o mancato pagamento rispetto ai termini stabiliti darà diritto a TRAMEC di sospendere qualsiasi consegna di prodotti e/o ordine in corso e richiedere al Cliente il pagamento degli interessi bancari così come previsto dalle leggi vigenti nella misura del tasso stabilito da BCE + 7% (Settepercento).

Ogni reclamo e/o contestazione non potrà comunque in nessun modo giustificare la sospensione o il ritardato pagamento.

8.8.1 Reclami e/o contestazioni

Ogni tipologia di reclamo o contestazione dovrà essere formalizzato/a a TRAMEC in forma scritta direttamente all'indirizzo email customer.care@tramec.it o attraverso la sezione "Customer Care" presente sul proprio sito www.tramec.it. Eventuali reclami riferiti a vizi o difetti dei prodotti ricevuti dovranno essere segnalati a TRAMEC, sempre in forma scritta, entro 10 (dieci) gg dalla data di consegna.

Nel caso che tali vizi o difetti si evidenziassero, per la loro natura, successivamente alla data di consegna, essi dovranno essere segnalati, sempre in forma scritta, a TRAMEC immediatamente entro e non oltre 5 (cinque) gg dalla data di rilevazione, e comunque saranno ritenuti tali entro e non oltre l'anno di garanzia previsto per i prodotti TRAMEC.

Le spese di trasporto sono a carico del Cliente salvo diverso accordo tra le parti.

8.6 Shipping and transport

Shipments will be handled by national and international carriers specified by the Customer, if specific instructions are not included they will be at TRAMEC's discretion. Where shipment is made at TRAMEC's discretion, carrier choice will be made based on convenience and delivery terms assured by the carriers. Goods are sold to Customer and considered EX-WORKS (see 8.5.PRICE OF THE PRODUCTS), all transportation expense, loss, damages, or delays to be the risk and responsibility of the Customer and their carrier, and not subject to TRAMEC warranty written or implied.

8.7 Terms of delivery

Delivery terms mentioned in "TRAMEC" Order Confirmation are considered agreed upon and to be honored bearing unexpected events outside "TRAMEC" control, in example:

- a) The Customers delay of technical or administrative information necessary for the timely dispatch of the products.*
- b) Difficulties in the acquisition of raw materials required to manufacture TRAMEC products.*
- c) Total or partial labor strikes, natural disasters, transportation difficulties or other circumstances beyond TRAMEC control.*
- d) Delays due to third parties or to be inbound shipping company*

The occurrence of some of the events listed or other not listed, do not entitle the customer to claim any compensation or claim for damages.

8.8 Payments

Unless stated in writing and agreed upon, "TRAMEC" will invoice the Customer on Confirmation of Order for Customers with Prepaid Terms, or at time of shipment for the Customers with NET trade credit terms. Payments are to be made in EURO, except where specific commercial agreements are made in alternative currencies. Payments must be made within the stated NET terms offered at time of Order Confirmation, regardless of outside claims or conflicts.

Delay or missing payments outside of the agreed terms will afford TRAMEC the right to suspend any delivery of products, services, and any pending orders, as well as require the Customer to pay interest on past due invoices, as provided by law, to the extent determined by the ECB rate + 7% (seven percent)

NO claim or dispute can justify the suspension, delay, or non-payment of invoices due.

8.8.1 Claims and / or disputes

Each complaint or claim must be transmitted in writing to "TRAMEC", directly to the e mail address customer.care@tramec.it or through the website www.tramec.it, "Customer Care" section.

Any claim relating to defect must be reported in writing to "TRAMEC" within 10 (ten) days of the receipt of the product.

If a defect is noticed or occurs after the delivery date, it must be reported in writing to TRAMEC within 5 (five) days of the date the defect was detected, and always within the 1 (one) year warranty provided for TRAMEC products.

Transportation costs are borne by the Customer unless otherwise agreed to by TRAMEC and the Customer.

8.8.2 Non conformità

Eventuali non corrispondenze in tipologia del prodotto e/o quantità, rispetto a quanto indicato in Conferma d'Ordine, dovrà essere prontamente segnalata in forma scritta a TRAMEC o al proprio agente di riferimento entro e non oltre 5(cinque) gg dalla data di consegna del materiale. Dopo tale scadenza i prodotti consegnati si riterranno conformi all'ordine del Cliente e non potranno essere più contestati a TRAMEC. Le spese di trasporto sono a carico del Cliente salvo diverso accordo tra le parti.

8.8.3 Restituzione del materiale

Il materiale non può essere restituito a TRAMEC, senza preventiva autorizzazione scritta da parte della stessa. Eventuali materiali ricevuti senza che il Cliente abbia effettuato una segnalazione scritta così come previsto ai punti 8.8.1 e 8.8.2, ed autorizzata da TRAMEC, verranno respinti al mittente, con addebito delle spese di trasporto salvo diverso accordo tra le parti.

8.8.4 Garanzia dei prodotti

TRAMEC garantisce i propri prodotti, così come previsto dalle leggi vigenti, per un periodo di 1(uno) anno dalla data di fatturazione degli stessi. La garanzia opererà su tutti i prodotti TRAMEC, ove saranno rilevabili difetti di costruzione, montaggio o progettazione e comporterà per TRAMEC l'onere della sostituzione o riparazione delle parti difettose senza nessun altro aggravio e/o addebiti per danni diretti e/o indiretti di qualsiasi natura.

La garanzia decade nel caso siano state eseguite riparazioni, modifiche o manomissioni senza autorizzazione scritta da parte di TRAMEC e nel caso di mancanza della targhetta originale di fabbrica, presente su tutti i prodotti TRAMEC.

Un uso negligente o improprio e inosservanza delle prescrizioni sull'uso, manutenzione e conservazione dei prodotti, comporterà la decadenza immediata della garanzia. Il prodotto, coperto da garanzia, dovrà essere restituito a TRAMEC, così come indicato al punto 8.8.3, con spese di trasporto a carico del Cliente salvo diverso accordo tra le parti. La proprietà del prodotto o componente sostituito in garanzia, ove risultasse difettoso, sarà trasferita a TRAMEC dal Cliente.

Ogni diritto di garanzia non sarà applicabile, su quei prodotti a cui ancora non siano stati completamente corrisposti, alle condizioni e termini pattuiti, i relativi importi dovuti così come da fattura di riferimento. TRAMEC inoltre non garantisce nessuna garanzia circa alle conformità dei prodotti a norme e regolamenti di Paesi o Stati che non rientrano e appartengano alla Comunità Europea.

8.9 Marchi e diritti di proprietà intellettuale

TRAMEC è l'unica titolare dei propri Marchi, ed il Cliente si asterrà dall'utilizzo degli stessi senza preventiva autorizzazione, o registrare Marchi simili e/o confondibili con i medesimi. Ogni loro utilizzo comunque dovrà essere autorizzato in forma scritta da TRAMEC sia nelle modalità che nella forma, secondo indicazioni concordate con il titolare dei Marchi.

Tutti i diritti di Proprietà Intellettuale sono di totale ed esclusiva proprietà di TRAMEC e la loro comunicazione o utilizzo nell'ambito delle presenti "Condizioni Generali di Vendita" non produce nessun diritto o pretesa in capo al Cliente, che si obbliga a non compiere atti o richieste a contestarne la Titolarità e Proprietà.

8.8.2 Non-compliance

Any non-compliance with either product or its quantity found to be different from what is stated on Order Confirmation, must be reported in writing to TRAMEC or its Agent, no later than 5 (five) days from the delivery date of the material.

With no notification made after this time, the products will be considered complying with the order acknowledged to the Customer and shall no longer be contested to TRAMEC. Transportation costs are borne by the Customer unless otherwise agreed to by TRAMEC and the Customer.

8.8.3 Return of material

No goods or materials can be returned without "TRAMEC" prior written authorization. Materials received without authorization and written report from the Customer, as required in point 8.8.1 & 8.8.2, and fully authorized by "TRAMEC", will be returned to the sender at the senders expense for all transportation and customs fees, unless otherwise agreed to between the parties in writing.

8.8.4 Product warranty

"TRAMEC" guarantees its products, as provided by law, for a period of 1 (one) year from the date of invoice. This guarantee will be valid for all "TRAMEC" products, where construction, installation or design defects will be detected and will lead to "TRAMEC" the burden of replacement or repair of defective parts at its discretion without any other burden or responsibility or charges for any direct and / or indirect damages or expense.

"TRAMEC" warranty is void if repairs, changes or alterations are carried out on the product without the written consent of "TRAMEC", and only valid with the original nameplate which is found on all "TRAMEC" products.

The negligent or improper use as well as failure to observe regulations governing the utilization, maintenance and storage of products, will result in the immediate loss of this guarantee. The product, covered by the warranty, will have to be returned to "TRAMEC" free of charge, as indicated in point 8.8.3, with all transportation costs borne by the Customer unless otherwise agreed between the parties in writing. The product or component replaced under warranty, if it is defective, will belong to "TRAMEC".

The warranty will not be valid for products that are not paid in full, according to the conditions and terms agreed, and for the amounts due per relevant invoice.

"TRAMEC" provides no guarantee as for the conformity of their products with the standards and regulations of Countries or States not belonging to the European Community.

8.9 Trademarks and intellectual property rights

TRAMEC is the sole owner of its brands, and the Customer will refrain from the use of them without prior authorization, or register similar ones and/or brands that are easily confused with TRAMEC's brands. Every use of TRAMEC brands requires the authorization in writing by TRAMEC, both in terms and form, according to instructions agreed with the owner of these trademarks.

All Intellectual Property Rights are the complete and exclusive property of TRAMEC and their communication or use under these "Terms of Sale" does not product any right or claim to the Customer, which is obliged to refrain from acts or request to question the Possessory title and Property.

8.10 Controversie e risoluzione contrattuale

Tutte le controversie derivanti da o connesse alle presenti Condizioni di Vendita e/o ad ogni vendita, sono assoggettabili alla esclusiva giurisdizione del Foro competente di Bologna (ITALIA).

TRAMEC Srl è legalmente domiciliata presso la sua sede principale di Via Bizzarri,6 – 70012 Calderara di Reno(BO) – ITALY.

8.10.1 Clausola risolutiva art. 1455 C.C.

TRAMEC avrà facoltà di risolvere, ai sensi e per gli effetti dell'art. 1455 del Codice Civile Italiano, in qualsiasi momento con comunicazione scritta al Cliente, la singola vendita nel caso di inadempimento delle obbligazioni così come previsto ai punti 8.5 (Prezzo dei Prodotti), 8.8 (Pagamenti), 8.9 (Marchi e Diritti di Proprietà Intellettuale).

8.10.2 Clausola risolutiva art. 1461 C.C.

TRAMEC avrà diritto di sospendere, ai sensi e per gli effetti dell'art. 1461 del Codice Civile Italiano, in qualsiasi momento con comunicazione scritta al Cliente, tutte le obbligazioni in corso derivanti dalla vendita dei prodotti, nel caso in cui le condizioni patrimoniali del Cliente divenissero e/o risultassero tali da porre in serio dubbio la naturale acquisizione della contropartita prevista.

TRAMEC potrà valutare eventuali garanzie accessorie proposte dal Cliente, come assicurazione sulle obbligazioni in essere.

8.10 Disputes and contract termination

All disputes due or related to these "Terms of Sale" and / or any sale, are subject to the exclusive jurisdiction of the Competent Court of Bologna (ITALY).

TRAMEC SRL is legally domiciled at its headquarters in Via Bizzarri, 6-70012 Calderara di Reno (BO) - ITALY.

8.10.1 Termination art. 1455 C.C. (Italian Civil Code)

"TRAMEC" may terminate, pursuant to art. 1455 of the Italian Civil Code, at any time by written notice to the Customer, the single sale in the event of breach of the obligations as set out in paragraphs 8.5 (Product Price), 8.8 (Payments), 8.9 (Trademarks and Intellectual Property Rights) .

8.10.2 Termination art. 1461 C.C. (Italian Civil Code)

"TRAMEC" will be entitled to suspend, pursuant to art. 1461 of the Italian Civil Code, at any time by written notice to the Customer, all current obligations arising from the sale of the products, in the event that the financial conditions of the Customer would become and/or result to call into serious doubt the natural acquisition of expected offset.

"TRAMEC" may consider any additional guarantees proposed by the Customer, such as insurance on outstanding obligations.

06/2022

Questo catalogo annulla e sostituisce ogni precedente edizione o revisione.
Tutti i dati elencati sono indicativi e s'intendono senza impegno alcuno da parte nostra.
Ci riserviamo il diritto di apportare modifiche senza preavviso.

*This catalogue cancels and replaces any previous edition and revision.
All listed data are approximate and it's understood that this entails no obligation on our part.
We reserve the right to implement modifications without notice.*

Mit der Ausgabe dieses Katalogs annullieren sich gleichzeitig alle bisherigen Katalogen.
Sämtliche Daten sind Berechnete Werte die für den Verkäufer unverbindlich sind.
Der Verkäufer behält sich das Recht vor, Änderungen, ohne eine vorhergehende Advisierung durchzuführen.



The first antibacterial gearbox in the world patented by "TRAMEC srl". The "GHA" gearbox comes from Italian inventiveness and is totally "Made in Italy"

Find out more information on www.ghapremium.com

Le premier réducteur antibactérien au monde breveté par TRAMEC srl. Le réducteur GHA est né de l'inventivité italienne et est totalement fabriqué en Italie.

Pour plus d'informations, visitez le site www.ghapremium.com

El primer reductor antibacteriano del mundo patentado por TRAMEC srl. El reductor GHA nace de la inventiva italiana y está totalmente hecho en Italia.

Para más información, visite el sitio www.ghapremium.com



Antibacterial properties
Propriétés antibactériennes
Propiedades antibacterianas



Corrosion resistance
Résistance à la corrosion
Resistencia a la corrosión



High thermal conductivity
Haute conductivité thermique
Alta conductividad térmica



High surface hardness
Haute dureté de surface
Alta dureza superficial